



MOTOTRBO™ MOBILE

PROFESSIONAL DIGITAL TWO-WAY RADIO

MOTOTRBO™ Mobile XPR 5350e/XPR 5550e/XPR 5380e/XPR 5580e DETAILED SERVICE MANUAL

MAY 2018

© 2018 Motorola Solutions, Inc. All rights reserved



MN002205A01-AB

Contents

List of Figures.....	5
List of Tables.....	13
Foreword.....	14
Product Safety and RF Exposure Compliance.....	14
Computer Software Copyrights.....	14
Document Copyrights.....	14
Disclaimer.....	14
Trademarks.....	15
Document History.....	16
Notations Used in This Manual.....	17
Commercial Warranty.....	18
I. What This Warranty Covers And For How Long.....	18
II. General Provisions.....	18
III. State Law Rights (Applicable Only in U.S.A.).....	19
IV. How To Get Warranty Service.....	19
V. What This Warranty Does Not Cover.....	19
VI. Patent And Software Provisions.....	19
VII. Governing Law.....	20
Chapter 1: Introduction.....	21
1.1 Radio Description.....	21
1.2 Summary of Printed Circuit Boards and Bands Available.....	21
Chapter 2: Maintenance.....	23
2.1 Preventive Maintenance.....	23
2.1.1 Inspection.....	23
2.1.2 Cleaning Procedures.....	23
2.1.3 Safe Handling of CMOS and LDMOS Devices.....	24
2.2 General Repair Procedures and Techniques.....	24
2.3 Pre-baking of Integrated Circuits.....	26
2.4 IPC/JEDEC J-STD-020D.1 (March 2008) Chart.....	27
Chapter 3: Test Equipment and Service Aids.....	29
3.1 Recommended Test Equipment.....	29
3.2 Service Aids.....	30
3.3 Programming Cables.....	30
Chapter 4: Power Up Self-Test.....	32
4.1 Power-Up Error Codes.....	32

Chapter 5: Control Head Service Information.....	33
5.1 Numeric Display Model.....	33
5.2 Color Display Model.....	33
Chapter 6: Mobile Radio Block Diagram.....	35
Chapter 7: Troubleshooting Charts.....	36
7.1 Troubleshooting Charts for Control Head.....	36
7.1.1 Numeric Display Model Control Head (PMLN7500_).....	36
7.1.2 Color Display Model Control Head (PMLN7501_).....	37
7.2 Troubleshooting Charts for Controller.....	40
7.3 Troubleshooting Charts for Part and Component.....	46
7.3.1 Troubleshooting Flowchart for Receiver.....	46
7.3.2 Troubleshooting Flow Chart for Transmitter.....	73
7.3.3 Troubleshooting Flow Chart for RFIC.....	80
7.3.4 Troubleshooting Flow Chart for Rx VCO.....	100
7.3.5 Troubleshooting Flow Chart for Tx VCO.....	111
7.4 Troubleshooting Chart for Bluetooth/GNSS/Wi-Fi (PMLN7252_S).....	120
7.5 Troubleshooting Chart for Generic Option Board (GOB).....	127
Chapter 8: Circuit Board, Schematic Diagrams, and Parts List.....	128
8.1 Control Head Service Information.....	128
8.1.1 Allocation of Schematics and Circuit Boards.....	128
8.1.1.1 Numeric Display Control Head Circuit Board and Schematic Diagram....	129
8.1.1.2 Parts List for Numeric Display Control Head.....	132
8.1.2 Allocation of Schematics and Circuit Boards.....	135
8.1.2.1 Color Display Control Head Circuit Board and Schematic Diagram.....	136
8.1.2.2 Parts List for Color Display Control Head.....	139
8.2 Controller Service Information.....	142
8.2.1 Allocation of Schematics and Parts Lists.....	142
8.2.1.1 Controller R3 Schematic Diagrams.....	144
8.2.1.2 Parts List for Controller R3.....	151
8.2.1.3 Controller R4 Schematic Diagrams.....	163
8.2.1.4 Parts List for Controller R4.....	170
8.2.1.5 Controller R5 Schematic Diagrams.....	182
8.2.1.6 Parts List for Controller R5.....	189
8.3 VHF Low Power Service Information.....	200
8.3.1 Allocation of Schematics and Circuit Boards.....	200
8.3.1.1 Circuit Board and Schematic Diagrams for 84012734001-A.....	202
8.3.1.2 Parts List for 84012734001-A	214
8.3.1.3 Circuit Board and Schematic Diagrams for 84012734002-B.....	239
8.3.1.4 Parts List for 84012734002-B.....	251

8.4 VHF High Power Service Information.....	264
8.4.1 Allocation of Schematics and Circuit Boards.....	264
8.4.1.1 Circuit Board and Schematic Diagrams for 84012736001-A.....	266
8.4.1.2 Parts List for 84012736001-A.....	278
8.4.1.3 Circuit Board and Schematic Diagrams for 84012736002-B.....	303
8.4.1.4 Parts List for 84012736002-B.....	315
8.5 UHF1 Low Power Service Information.....	328
8.5.1 Allocation of Schematics and Circuit Boards.....	328
8.5.1.1 Circuit Board and Schematic Diagrams for 84012735001-A.....	330
8.5.1.2 Parts List for 84012735001-A.....	342
8.5.1.3 Circuit Board and Schematic Diagrams for 84012735003-C.....	367
8.5.1.4 Parts List for 84012735003-C.....	379
8.6 UHF1 High Power Service Information.....	394
8.6.1 Allocation of Schematics and Circuit Boards.....	394
8.6.1.1 Circuit Board and Schematic Diagrams for 84012737001-A.....	395
8.6.1.2 Parts List for 84012737001-A.....	407
8.6.1.3 Circuit Board and Schematic Diagrams for 84012737003-C.....	433
8.6.1.4 Parts List for 84012737003-C.....	445
8.7 UHF2 Service Information.....	459
8.7.1 Allocation of Schematics and Circuit Boards.....	459
8.7.1.1 Circuit Board and Schematic Diagrams for 84012728001-A.....	461
8.7.1.2 Parts List for 84012728001-A.....	475
8.7.1.3 Circuit Board and Schematic Diagrams for 84012728003-C.....	502
8.7.1.4 Parts List for 84012728003-C.....	516
8.8 800/900 Band Service Information.....	531
8.8.1 Allocation of Schematics and Circuit Boards.....	531
8.8.1.1 Circuit Board and Schematic Diagrams for 84012657001-A.....	532
8.8.1.2 Parts List for 84012657001-A.....	543
8.9 Bluetooth/Wi-Fi/GNSS (PMLN7252_S) Expansion Board Service Information.....	569
8.9.1 Allocation of Schematic and Circuit Board.....	569
8.9.1.1 Circuit Board and Schematic Diagrams for PC000942A01-AA.....	571
8.9.1.2 Parts List for PC000942A01-AA.....	577
8.10 Generic Option Board (GOB) Service Information.....	578
8.10.1 Allocation of Schematic and Circuit Board.....	578
8.10.1.1 Circuit Board and Schematic Diagram for PC000957A01-CA.....	579
8.10.1.2 Parts List for PC000957A01-CA.....	582
Appendix A: Replacement Parts Ordering.....	584
Appendix B: Motorola Solutions Service Centers.....	586
Glossary.....	587

List of Figures

Figure 1: Mobile Front Programming Cable HKN6184_.....	30
Figure 2: Mobile & Repeater Rear Programming Cable PMKN4010_.....	31
Figure 3: Mobile & Repeater Rear Accessory Programming and Test Cable PMKN4016_.....	31
Figure 4: Numeric Display Model (PMLN7500_).....	33
Figure 5: Color Display Model (PMLN7501_).....	34
Figure 6: Top Level Block Diagram for PCB No. PC000942A01-AA.....	35
Figure 7: Troubleshooting Flow Chart for On/Off.....	36
Figure 8: Troubleshooting Flow Chart for On/Off.....	37
Figure 9: Troubleshooting Flow Chart for Display.....	38
Figure 10: Troubleshooting Flow Chart for Backlight.....	39
Figure 11: Troubleshooting Chart for Controller.....	40
Figure 12: Troubleshooting Chart for Power-Up.....	41
Figure 13: Troubleshooting Chart for MAP USB (Device Mode).....	42
Figure 14: Troubleshooting Chart for MMP USB (Device Mode).....	43
Figure 15: Troubleshooting Chart for MMP USB (Host Mode).....	44
Figure 16: Troubleshooting Chart for Audio.....	45
Figure 17: Troubleshooting Flow Chart for Receiver for 84012734001-A (Sheet 1 of 3).....	46
Figure 18: Troubleshooting Flow Chart for Receiver for 84012734001-A (Sheet 2 of 3).....	47
Figure 19: Troubleshooting Flow Chart for Receiver for 84012734001-A (Sheet 3 of 3).....	48
Figure 20: Troubleshooting Flow Chart for Receiver for 84012734002-B (Sheet 1 of 3).....	49
Figure 21: Troubleshooting Flow Chart for Receiver for 84012734002-B (Sheet 2 of 3).....	50
Figure 22: Troubleshooting Flow Chart for Receiver for 84012734002-B (Sheet 3 of 3).....	51
Figure 23: Troubleshooting Flow Chart for Receiver for 84012735001-A (Sheet 1 of 3).....	52
Figure 24: Troubleshooting Flow Chart for Receiver for 84012735001-A (Sheet 2 of 3).....	53
Figure 25: Troubleshooting Flow Chart for Receiver for 84012735001-A (Sheet 3 of 3).....	54
Figure 26: Troubleshooting Flow Chart for Receiver for 84012735003-C (Sheet 1 of 3).....	55
Figure 27: Troubleshooting Flow Chart for Receiver for 84012735003-C (Sheet 2 of 3).....	56
Figure 28: Troubleshooting Flow Chart for Receiver for 84012735003-C (Sheet 3 of 3).....	57
Figure 29: Troubleshooting Flow Chart for Receiver for 84012737001-A (Sheet 1 of 3).....	58
Figure 30: Troubleshooting Flow Chart for Receiver for 84012737001-A (Sheet 2 of 3).....	59
Figure 31: Troubleshooting Flow Chart for Receiver for 84012737001-A (Sheet 3 of 3).....	60
Figure 32: Troubleshooting Flow Chart for Receiver for 84012737003-C (Sheet 1 of 3).....	61
Figure 33: Troubleshooting Flow Chart for Receiver for 84012737003-C (Sheet 2 of 3).....	62
Figure 34: Troubleshooting Flow Chart for Receiver for 84012737003-C (Sheet 3 of 3).....	63
Figure 35: Troubleshooting Flow Chart for Receiver for 84012728001-A (Sheet 1 of 3).....	64
Figure 36: Troubleshooting Flow Chart for Receiver for 84012728001-A (Sheet 2 of 3).....	65

Figure 37: Troubleshooting Flow Chart for Receiver for 84012728001-A (Sheet 3 of 3).....	66
Figure 38: Troubleshooting Flow Chart for Receiver for 84012728003-C (Sheet 1 of 3).....	67
Figure 39: Troubleshooting Flow Chart for Receiver for 84012728003-C (Sheet 2 of 3).....	68
Figure 40: Troubleshooting Flow Chart for Receiver for 84012728003-C (Sheet 3 of 3).....	69
Figure 41: Troubleshooting Flow Chart for Receiver (Sheet 1 of 3).....	70
Figure 42: Troubleshooting Flow Chart for Receiver (Sheet 2 of 3).....	71
Figure 43: Troubleshooting Flow Chart for Receiver (Sheet 3 of 3).....	72
Figure 44: Troubleshooting Flow Chart for Transmitter.....	73
Figure 45: Troubleshooting Flow Chart for Transmitter.....	74
Figure 46: Troubleshooting Flow Chart for Transmitter.....	75
Figure 47: Troubleshooting Flow Chart for Transmitter.....	76
Figure 48: Troubleshooting Flow Chart for Transmitter.....	77
Figure 49: Troubleshooting Flow Chart for Transmitter.....	78
Figure 50: Troubleshooting Flow Chart for Transmitter.....	79
Figure 51: Troubleshooting Flow Chart for RFIC (Sheet 1 of 5).....	80
Figure 52: Troubleshooting Flow Chart for RFIC (Sheet 2 of 5).....	81
Figure 53: Troubleshooting Flow Chart for RFIC (Sheet 3 of 5).....	82
Figure 54: Troubleshooting Flow Chart for RFIC (Sheet 4 of 5).....	83
Figure 55: Troubleshooting Flow Chart for RFIC (Sheet 5 of 5).....	84
Figure 56: Troubleshooting Flow Chart for RFIC (Sheet 1 of 5).....	85
Figure 57: Troubleshooting Flow Chart for RFIC (Sheet 2 of 5).....	86
Figure 58: Troubleshooting Flow Chart for RFIC (Sheet 3 of 5).....	87
Figure 59: Troubleshooting Flow Chart for RFIC (Sheet 4 of 5).....	88
Figure 60: Troubleshooting Flow Chart for RFIC (Sheet 5 of 5).....	89
Figure 61: Troubleshooting Flow Chart for RFIC (Sheet 1 of 5).....	90
Figure 62: Troubleshooting Flow Chart for RFIC (Sheet 2 of 5).....	91
Figure 63: Troubleshooting Flow Chart for RFIC (Sheet 3 of 5).....	92
Figure 64: Troubleshooting Flow Chart for RFIC (Sheet 4 of 5).....	93
Figure 65: Troubleshooting Flow Chart for RFIC (Sheet 5 of 5).....	94
Figure 66: Troubleshooting Flow Chart for RFIC (Sheet 1 of 5).....	95
Figure 67: Troubleshooting Flow Chart for RFIC (Sheet 2 of 5).....	96
Figure 68: Troubleshooting Flow Chart for RFIC (Sheet 3 of 5).....	97
Figure 69: Troubleshooting Flow Chart for RFIC (Sheet 4 of 5).....	98
Figure 70: Troubleshooting Flow Chart for RFIC (Sheet 5 of 5).....	99
Figure 71: Troubleshooting Flow Chart for Rx VCO (Sheet 1 of 2).....	100
Figure 72: Troubleshooting Flow Chart for Rx VCO (Sheet 2 of 2).....	101
Figure 73: Troubleshooting Flow Chart for Rx VCO (Sheet 1 of 3).....	102
Figure 74: Troubleshooting Flow Chart for Rx VCO (Sheet 2 of 3).....	103
Figure 75: Troubleshooting Flow Chart for Rx VCO (Sheet 3 of 3).....	104

Figure 76: Troubleshooting Flow Chart for Rx VCO (Sheet 1 of 3).....	105
Figure 77: Troubleshooting Flow Chart for Rx VCO (Sheet 2 of 3).....	106
Figure 78: Troubleshooting Flow Chart for Rx VCO (Sheet 3 of 3).....	107
Figure 79: Troubleshooting Flow Chart for Rx VCO (Sheet 1 of 3).....	108
Figure 80: Troubleshooting Flow Chart for Rx VCO (Sheet 2 of 3).....	109
Figure 81: Troubleshooting Flow Chart for Rx VCO (Sheet 3 of 3).....	110
Figure 82: Troubleshooting Flow Chart for Tx VCO (Sheet 1 of 2).....	111
Figure 83: Troubleshooting Flow Chart for Tx VCO (Sheet 2 of 2).....	112
Figure 84: Troubleshooting Flow Chart for Tx VCO (Sheet 1 of 2).....	113
Figure 85: Troubleshooting Flow Chart for Tx VCO (Sheet 2 of 2).....	114
Figure 86: Troubleshooting Flow Chart for Tx VCO (Sheet 1 of 2).....	115
Figure 87: Troubleshooting Flow Chart for Tx VCO (Sheet 2 of 2).....	116
Figure 88: Troubleshooting Flow Chart for Tx VCO (Sheet 1 of 3).....	117
Figure 89: Troubleshooting Flow Chart for Tx VCO (Sheet 2 of 3).....	118
Figure 90: Troubleshooting Flow Chart for Tx VCO (Sheet 3 of 3).....	119
Figure 91: Troubleshooting Flow Chart for Bluetooth (Sheet 1 of 4).....	120
Figure 92: Troubleshooting Flow Chart for Bluetooth (Sheet 2 of 4).....	121
Figure 93: Troubleshooting Flow Chart for Bluetooth (Sheet 3 of 4).....	122
Figure 94: Troubleshooting Flow Chart for Bluetooth (Sheet 4 of 4).....	123
Figure 95: Troubleshooting Flow Chart for GNSS (Sheet 1 of 3).....	123
Figure 96: Troubleshooting Flow Chart for GNSS (Sheet 2 of 3).....	124
Figure 97: Troubleshooting Flow Chart for GNSS (Sheet 3 of 3).....	124
Figure 98: Troubleshooting Flow Chart for Wi-Fi (Sheet 1 of 2).....	125
Figure 99: Troubleshooting Flow Chart for Wi-Fi (Sheet 2 of 2).....	126
Figure 100: Troubleshooting Flow Chart for GOB (PMLN7324_S).....	127
Figure 101: Numeric Display Control Head Top Side PCB No. 84012212002-B	129
Figure 102: Numeric Display Control Head Bottom Side PCB No. 84012212002-B	130
Figure 103: Numeric Display Control Head Schematic Diagram.....	131
Figure 104: Color Display Control Head Top Side PCB No. 84012211002-B.....	136
Figure 105: Colour Display Control Head Bottom Side PCB No. 84012211002-B.....	137
Figure 106: Color Display Control Head Schematic Diagram.....	138
Figure 107: Controller Top Level Schematic Diagram.....	144
Figure 108: Controller DC Supply Schematic Diagram.....	145
Figure 109: Controller Audio Schematic Diagram.....	146
Figure 110: Controller Peripheral Schematic Diagram (Sheet 1 of 2).....	147
Figure 111: Controller Peripheral Schematic Diagram (Sheet 2 of 2).....	148
Figure 112: Controller Microprocessor Schematic Diagram.....	149
Figure 113: Controller Memories Schematic Diagram.....	150
Figure 114: Controller Top Level Schematic Diagram.....	163

Figure 115: Controller DC Supply Schematic Diagram.....	164
Figure 116: Controller Audio Schematic Diagram.....	165
Figure 117: Controller Peripheral Schematic Diagram (Sheet 1 of 2).....	166
Figure 118: Controller Peripheral Schematic Diagram (Sheet 2 of 2).....	167
Figure 119: Controller Microprocessor Schematic Diagram.....	168
Figure 120: Controller Memories Schematic Diagram.....	169
Figure 121: Controller Top Level Schematic Diagram.....	182
Figure 122: Controller DC Supply Schematic Diagram.....	183
Figure 123: Controller Audio Schematic Diagram.....	184
Figure 124: Controller Peripheral Schematic Diagram (Sheet 1 of 2).....	185
Figure 125: Controller Peripheral Schematic Diagram (Sheet 2 of 2).....	186
Figure 126: Controller Microprocessor Schematic Diagram.....	187
Figure 127: Controller Memories Schematic Diagram.....	188
Figure 128: Main Board Top Side PCB No. 84012734001-A.....	202
Figure 129: Main Board Bottom Side PCB No. 84012734001-A.....	203
Figure 130: Overall Schematic Diagram.....	204
Figure 131: Receiver Front-End Schematic Diagram.....	205
Figure 132: Receiver IF Amp Schematic Diagram.....	206
Figure 133: Transmitter Power Amplifier Schematic Diagram.....	207
Figure 134: Power Control Schematic Diagram.....	208
Figure 135: Transmitter Power Amplifier DC Distribution Schematic Diagram.....	209
Figure 136: RFIC Schematic Diagram.....	210
Figure 137: Receiver VCO Schematic Diagram.....	211
Figure 138: Transmit VCO Schematic Diagram.....	212
Figure 139: VCO Buffer Schematic Diagram.....	213
Figure 140: Main Board Top Side PCB No. 84012734002-B.....	239
Figure 141: Main Board Bottom Side PCB No. 84012734002-B.....	240
Figure 142: Overall Schematic Diagram.....	241
Figure 143: Receiver Front End Schematic Diagram.....	242
Figure 144: Receiver IF Amp Schematic Diagram.....	243
Figure 145: Transmitter Power Amplifier Schematic Diagram.....	244
Figure 146: Power Control Schematic Diagram.....	245
Figure 147: Transmitter Power Amplifier DC Distribution Schematic Diagram.....	246
Figure 148: RFIC Schematic Diagram.....	247
Figure 149: Receiver VCO Schematic Diagram.....	248
Figure 150: Transmit VCO Schematic Diagram.....	249
Figure 151: VCO Buffer Schematic Diagram.....	250
Figure 152: Main Board Top Side PCB No. 84012736001-A.....	266
Figure 153: Main Board Bottom Side PCB No. 84012736001-A.....	267

Figure 154: Overall Schematic Diagram.....	268
Figure 155: Receiver Front-End Schematic Diagram.....	269
Figure 156: Receiver IF Amp Schematic Diagram.....	270
Figure 157: Transmitter Power Amplifier Schematic Diagram.....	271
Figure 158: Power Control Schematic Diagram.....	272
Figure 159: Transmitter Power Amplifier DC Distribution Schematic Diagram.....	273
Figure 160: RFIC Schematic Diagram.....	274
Figure 161: Receiver VCO Schematic Diagram.....	275
Figure 162: Transmit VCO Schematic Diagram.....	276
Figure 163: VCO Buffer Schematic Diagram.....	277
Figure 164: Main Board Top Side PCB No. 84012736002-B.....	303
Figure 165: Main Board Bottom Side PCB No. 84012736002-B.....	304
Figure 166: Overall Schematic Diagram.....	305
Figure 167: Receiver Front End Schematic Diagram.....	306
Figure 168: Receiver IF Amp Schematic Diagram.....	307
Figure 169: Transmitter Power Amplifier Schematic Diagram.....	308
Figure 170: Power Control Schematic Diagram.....	309
Figure 171: Transmitter Power Amplifier DC Distribution Schematic Diagram.....	310
Figure 172: RFIC Schematic Diagram.....	311
Figure 173: Receiver VCO Schematic Diagram.....	312
Figure 174: Transmit VCO Schematic Diagram.....	313
Figure 175: VCO Buffer Schematic Diagram.....	314
Figure 176: Main Board Top Side PCB No. 84012735001-A.....	330
Figure 177: Main Board Bottom Side PCB No. 84012735001-A.....	331
Figure 178: Overall Schematic Diagram.....	332
Figure 179: Receiver Front-End Schematic Diagram.....	333
Figure 180: Receiver IF Amp Schematic Diagram.....	334
Figure 181: Transmitter Power Amplifier Schematic Diagram.....	335
Figure 182: Power Control Schematic Diagram.....	336
Figure 183: Transmitter Power Amplifier DC Distribution Schematic Diagram.....	337
Figure 184: RFIC Schematic Diagram.....	338
Figure 185: Receiver VCO Schematic Diagram.....	339
Figure 186: Transmit VCO Schematic Diagram.....	340
Figure 187: VCO Buffer Schematic Diagram.....	341
Figure 188: Main Board Top Side PCB No. 84012735003-C.....	367
Figure 189: Main Board Bottom Side PCB No. 84012735003-C.....	368
Figure 190: Overall Schematic Diagram.....	369
Figure 191: Receiver Front-End Schematic Diagram.....	370
Figure 192: Receiver IF Amp Schematic Diagram.....	371

Figure 193: Transmitter Power Amplifier Schematic Diagram.....	372
Figure 194: Power Control Schematic Diagram.....	373
Figure 195: Transmitter Power Amplifier DC Distribution Schematic Diagram.....	374
Figure 196: RFIC Schematic Diagram.....	375
Figure 197: Receiver VCO Schematic Diagram.....	376
Figure 198: Transmit VCO Schematic Diagram.....	377
Figure 199: VCO Buffer Schematic Diagram.....	378
Figure 200: Main Board Top Side PCB No. 84012737001-A.....	395
Figure 201: Main Board Bottom Side PCB No. 84012737001-A.....	396
Figure 202: Overall Schematic Diagram.....	397
Figure 203: Receiver Front-End Schematic Diagram.....	398
Figure 204: Receiver IF Amp Schematic Diagram.....	399
Figure 205: Transmitter Power Amplifier Schematic Diagram.....	400
Figure 206: Power Control Schematic Diagram.....	401
Figure 207: Transmitter Power Amplifier DC Distribution Schematic Diagram.....	402
Figure 208: RFIC Schematic Diagram.....	403
Figure 209: Receiver VCO Schematic Diagram.....	404
Figure 210: Transmit VCO Schematic Diagram.....	405
Figure 211: VCO Buffer Schematic Diagram.....	406
Figure 212: Main Board Top Side PCB No. 84012737003-C.....	433
Figure 213: Main Board Bottom Side PCB No. 84012737003-C.....	434
Figure 214: Overall Schematic Diagram.....	435
Figure 215: Receiver Front-End Schematic Diagram.....	436
Figure 216: Receiver IF Amp Schematic Diagram.....	437
Figure 217: Transmitter Power Amplifier Schematic Diagram.....	438
Figure 218: Power Control Schematic Diagram.....	439
Figure 219: Transmitter Power Amplifier DC Distribution Schematic Diagram.....	440
Figure 220: RFIC Schematic Diagram.....	441
Figure 221: Receiver VCO Schematic Diagram.....	442
Figure 222: Transmit VCO Schematic Diagram.....	443
Figure 223: VCO Buffer Schematic Diagram.....	444
Figure 224: Main Board Top Side PCB No. 84012728001-A.....	461
Figure 225: Main Board Bottom Side PCB No. 84012728001-A.....	462
Figure 226: Overall Schematic Diagram.....	463
Figure 227: Receiver Front-End Schematic Diagram.....	464
Figure 228: Receiver IF Amp Schematic Diagram.....	465
Figure 229: Transmitter Power Amplifier Schematic Diagram (Sheet 1 of 3).....	466
Figure 230: Transmitter Power Amplifier Schematic Diagram (Sheet 2 of 3).....	467
Figure 231: Transmitter Power Amplifier Schematic Diagram (Sheet 3 of 3).....	468

Figure 232: Power Control Schematic Diagram.....	469
Figure 233: Transmitter Power Amplifier DC Distribution Schematic Diagram.....	470
Figure 234: RFIC Schematic Diagram.....	471
Figure 235: Receiver VCO Schematic Diagram.....	472
Figure 236: Transmit VCO Schematic Diagram.....	473
Figure 237: VCO Buffer Schematic Diagram.....	474
Figure 238: Main Board Top Side PCB No. 84012728003-C.....	502
Figure 239: Main Board Bottom Side PCB No. 84012728003-C.....	503
Figure 240: Overall Schematic Diagram.....	504
Figure 241: Receiver Front-End Schematic Diagram.....	505
Figure 242: Receiver IF Amp Schematic Diagram.....	506
Figure 243: Transmit Power Amplifier Schematic Diagram (Sheet 1 of 3).....	507
Figure 244: Transmit Power Amplifier Schematic Diagram (Sheet 2 of 3).....	508
Figure 245: Transmit Power Amplifier Schematic Diagram (Sheet 3 of 3).....	509
Figure 246: Power Control Schematic Diagram.....	510
Figure 247: Transmit Power Amplifier DC Distribution Schematic Diagram.....	511
Figure 248: RFIC Schematic Diagram.....	512
Figure 249: Receiver VCO Schematic Diagram.....	513
Figure 250: Transmit VCO Schematic Diagram.....	514
Figure 251: VCO Buffer Schematic Diagram.....	515
Figure 252: Main Board Top Side PCB No. 84012657001-A.....	532
Figure 253: Main Board Bottom Side PCB No. 84012657001-A.....	533
Figure 254: Overall Schematic Diagram.....	534
Figure 255: Receiver Front-End Schematic Diagram.....	535
Figure 256: Receiver IF Amp Schematic Diagram.....	536
Figure 257: Transmitter Power Amplifier Schematic Diagram.....	537
Figure 258: Power Control Schematic Diagram.....	538
Figure 259: Transmitter Power Amplifier DC Distribution Schematic Diagram.....	539
Figure 260: RFIC Schematic Diagram.....	540
Figure 261: VCO Schematic Diagram.....	541
Figure 262: VCO Buffer Schematic Diagram.....	542
Figure 263: Expansion Board Top Side PCB No. PC000942A01-AA.....	571
Figure 264: Expansion Board Bottom Side PCB No. PC000942A01-AA.....	572
Figure 265: Expansion Board Schematic Diagram (Sheet 1 of 4).....	573
Figure 266: Expansion Board Schematic Diagram (Sheet 2 of 4).....	574
Figure 267: Expansion Board Schematic Diagram (Sheet 3 of 4).....	575
Figure 268: Expansion Board Schematic Diagram (Sheet 4 of 4).....	576
Figure 269: GOB Top Side PCB No. PC000957A01-CA.....	579
Figure 270: GOB Bottom Side PCB No. PC000957A01-CA.....	580

Figure 271: GOB Schematic Diagram..... 581

List of Tables

Table 1: Radio Frequency Ranges and Power Levels.....	21
Table 2: Lead Free Solder Wire Part Number List.....	25
Table 3: Lead Free Solder Paste Part Number List.....	25
Table 4: MS Components and Location.....	26
Table 5: Moisture Sensitivity Levels.....	27
Table 6: Test Equipments.....	29
Table 7: Service Aids.....	30
Table 8: Power-Up Error Codes.....	32
Table 9: Numeric Display Control Head Parts List (PMLN7500_).....	132
Table 10: Color Display Control Head Parts List (PMLN7501_).....	139
Table 11: PC Boards using Controller R3.....	142
Table 12: PC Boards using Controller R4.....	142
Table 13: PC Boards using Controller R5.....	142
Table 14: Controller R3 Parts List.....	151
Table 15: Controller R4 Parts List.....	170
Table 16: Controller R5 Parts List.....	189
Table 17: VHF Radio Part List.....	214
Table 18: VHF Radio Parts List.....	251
Table 19: VHF Radio Part Lists.....	278
Table 20: VHF Radio Parts List.....	315
Table 21: UHF1 Radio Parts List.....	342
Table 22: UHF1 Radio Parts List.....	379
Table 23: UHF1 Radio Parts List.....	407
Table 24: UHF1 Radio Parts List.....	445
Table 25: UHF2 Radio Parts List.....	475
Table 26: UHF2 Radio Parts List.....	516
Table 27: 800/900 MHz Radio Parts List.....	543
Table 28: Bluetooth/Wi-Fi/GNSS (PMLN7252_S) Expansion Board Parts List.....	577
Table 29: GOB Parts List.....	582

Foreword

This manual includes all the information necessary to maintain peak product performance and maximum working time, using level 3 maintenance procedures.

This level of service provides sufficient information to enable qualified service technicians to troubleshoot and repair the product to the component level. For details on product operation or basic troubleshooting, refer to the applicable manuals available separately.



CAUTION: These servicing instructions are for use by qualified personnel only. To reduce the risk of electric shock, do not perform any servicing other than that contained in the Operating Instructions unless you are qualified to do so. Refer all servicing to qualified service personnel.

Product Safety and RF Exposure Compliance



CAUTION: Before using this product, read the Product Safety and RF Exposure booklet enclosed with your radio which contains important operating instructions for safe usage and RF energy awareness and control for Compliance with applicable Standards and Regulations.

For a list of Motorola Solutions-approved antennas, batteries, and other accessories, visit the following web site: <http://www.motorolasolutions.com>

Computer Software Copyrights

The Motorola Solutions products described in this manual may include copyrighted Motorola Solutions computer programs stored in semiconductor memories or other media. Laws in the United States and other countries preserve for Motorola Solutions certain exclusive rights for copyrighted computer programs, including, but not limited to, the exclusive right to copy or reproduce in any form the copyrighted computer program. Accordingly, any copyrighted Motorola Solutions computer programs contained in the Motorola Solutions products described in this manual may not be copied, reproduced, modified, reverse-engineered, or distributed in any manner without the express written permission of Motorola Solutions. Furthermore, the purchase of Motorola Solutions products shall not be deemed to grant either directly or by implication, estoppel, or otherwise, any license under the copyrights, patents or patent applications of Motorola Solutions, except for the normal non-exclusive license to use that arises by operation of law in the sale of a product.

Document Copyrights

No duplication or distribution of this document or any portion thereof shall take place without the express written permission of Motorola Solutions. No part of this manual may be reproduced, distributed, or transmitted in any form or by any means, electronic or mechanical, for any purpose without the express written permission of Motorola Solutions.

Disclaimer

The information in this document is carefully examined, and is believed to be entirely reliable. However, no responsibility is assumed for inaccuracies. Furthermore, Motorola Solutions reserves the right to make changes to any products herein to improve readability, function, or design. Motorola Solutions does not assume any liability arising out of the applications or use of any product or circuit described herein; nor does it cover any license under its patent rights nor the rights of others.

Trademarks

MOTOROLA, MOTO, MOTOROLA SOLUTIONS and the Stylized M logo are trademarks or registered trademarks of Motorola Trademark Holdings, LLC and are used under license. All other trademarks are the property of their respective owners.

© 2018 Motorola Solutions, Inc. All rights reserved.

Document History

The following major changes have been implemented in this manual since the previous edition:

Edition	Description	Date
MN002205A01-AA	Initial Release.	November 2015
MN002205A01-AB	Added new UHF1 Low Power and High Power Schematic Diagrams, Circuit Board, and Parts List for PCB 84012735003-C and 84012737003-C.	May 2018
	Added new VHF Low Power and High Power Schematic Diagrams, Circuit Board, and Parts List for PCB 84012734002-B and 84012736002-B.	
	Added Troubleshooting Flow Chart for Receiver (Sheet 2 and 3) for VHF Low Power and High Power band and also UHF1 Low Power and High Power band.	
	Updated GOB Parts List.	
	Updated Summary of Printed Circuit Boards and Bands available Chapter.	
	Added new UHF2 Troubleshooting Charts.	
	Added new UHF2 Schematic Diagrams, Circuit Board, and Parts List for PCB 84012728003-C.	

Notations Used in This Manual

Throughout the text in this publication, you will notice the use of warning, caution, and notice notations. These notations are used to emphasize that safety hazards exist, and due care must be taken and observed.



WARNING: WARNING indicates a potentially hazardous situation which, if not avoided, could result in death or injury.



CAUTION: CAUTION indicates a potentially hazardous situation which, if not avoided, might result in equipment damage.



NOTICE: NOTICE indicates an operational procedure, practice, or condition that is essential to emphasize.

Commercial Warranty

Limited Warranty

For information on warranty terms, see the Support page at <https://www.motorolasolutions.com>.

I. What This Warranty Covers And For How Long

Motorola Solutions Inc. ("Motorola Solutions") warrants the Motorola Solutions manufactured Communication Products listed below ("Product") against defects in material and workmanship under normal use and service for a period of time from the date of purchase as scheduled below:

Mobile Radios	Two Years
Product Accessories	One Year

The radios additionally ship with a standard 1-year Repair Service Advantage (RSA) (for U.S. customers) or 1-year Extended Warranty (for Canada customers). However, at the time of order, you may choose to omit these warranties. For more RSA or Extended Warranty information, please refer to the price pages or Motorola Online (<https://businessonline.motorolasolutions.com>) > Resource Center > Services > Service Product Offerings > Repair Service Advantage or Extended Warranty.

Motorola Solutions, at its option, will at no charge either repair the Product (with new or reconditioned parts), replace it (with a new or reconditioned Product), or refund the purchase price of the Product during the warranty period provided it is returned in accordance with the terms of this warranty. Replaced parts or boards are warranted for the balance of the original applicable warranty period. All replaced parts of Product shall become the property of Motorola Solutions.

This express limited warranty is extended by Motorola Solutions to the original end user purchaser only and is not assignable or transferable to any other party. This is the complete warranty for the Product manufactured by Motorola Solutions. Motorola Solutions assumes no obligations or liability for additions or modifications to this warranty unless made in writing and signed by an officer of Motorola Solutions. Unless made in a separate agreement between Motorola Solutions and the original end user purchaser, Motorola Solutions does not warrant the installation, maintenance or service of the Product.

Motorola Solutions cannot be responsible in any way for any ancillary equipment not furnished by Motorola Solutions which is attached to or used in connection with the Product, or for operation of the Product with any ancillary equipment, and all such equipment is expressly excluded from this warranty. Because each system which may use the Product is unique, Motorola Solutions disclaims liability for range, coverage, or operation of the system as a whole under this warranty.

II. General Provisions

This warranty sets forth the full extent of Motorola Solutions responsibilities regarding the Product. Repair, replacement or refund of the purchase price, at Motorola Solutions option, is the exclusive remedy.

This warranty is given in lieu of all other express warranties, implied warranties, including without limitation, implied warranties of merchantability and fitness for a particular purpose, are limited to the duration of this limited warranty. In no event shall Motorola Solutions be liable for damages in excess of the purchase price of the product, for any loss of use, loss of time, inconvenience, commercial loss, lost profits or savings or other incidental, special or consequential damages arising out of the use or inability to use such product, to the full extent such may be disclaimed by law.

III. State Law Rights (Applicable Only in U.S.A.)

Some states do not allow the exclusion or limitation of incidental or consequential damages or limitation on how long an implied warranty lasts, so the above limitation or exclusions may not apply.

This warranty gives specific legal rights, and there may be other rights which may vary from state to state.

IV. How To Get Warranty Service

You must provide proof of purchase (bearing the date of purchase and Product item serial number) in order to receive warranty service and, also, deliver or send the Product item, transportation, and insurance prepaid, to an authorized warranty service location.

Warranty service will be provided by Motorola Solutions through one of its authorized warranty service locations. If you first contact the company which sold you the Product, it can facilitate your obtaining warranty service.

You can also call Motorola Solutions at 1-800-927-2744 US/Canada.

V. What This Warranty Does Not Cover

This warranty does not cover the following conditions:

- Defects or damage resulting from use of the Product in other than its normal and customary manner.
- Defects or damage from misuse, accident, water, or neglect.
- Defects or damage from improper testing, operation, maintenance, installation, alteration, modification, or adjustment.
- Breakage or damage to antennas unless caused directly by defects in material workmanship.
- A Product subjected to unauthorized Product modifications, disassemblies or repairs (including, without limitation, the addition to the Product of non-Motorola Solutions supplied equipment) which adversely affect performance of the Product or interfere with Motorola Solutions normal warranty inspection and testing of the Product to verify any warranty claim.
- Product which has had the serial number removed or made illegible.
- Rechargeable batteries if:
 - Any of the seals on the battery enclosure or cells are broken or show evidence of tampering.
 - The damage or defect is caused by charging or using the battery in equipment or service other than the Product for which it is specified.
- Freight costs to the repair depot.
- A Product which, due to illegal or unauthorized alteration of the software/firmware in the Product, does not function in accordance with Motorola Solutions published specifications or the FCC type acceptance labeling in effect for the Product at the time the Product was initially distributed from Motorola Solutions.
- Scratches or other cosmetic damage to Product surfaces that does not affect the operation of the Product.
- Normal and customary wear and tear.

VI. Patent And Software Provisions

Motorola Solutions will defend, at its own expense, any suit brought against the end user purchaser to the extent that it is based on a claim that the Product or parts infringe a United States patent, and

Motorola Solutions will pay those costs and damages finally awarded against the end user purchaser in any such suit which are attributable to any such claim.

But such defense and payments are conditioned on the following:

- Motorola Solutions will be notified promptly in writing by such purchaser of any notice of such claim.
- Motorola Solutions will have sole control of the defense of such suit and all negotiations for its settlement or compromise.
- Product or parts become, or in Motorola Solutions opinion be likely to become, the subject of a claim of infringement of a United States patent, that such purchaser will permit Motorola Solutions, at its option and expense, either to procure for such purchaser the right to continue using the Product or parts or to replace or modify the same so that it becomes noninfringing or to grant such purchaser a credit for the Product or parts as depreciated and accept its return. The depreciation will be an equal amount per year over the lifetime of the Product or parts as established by Motorola Solutions.

Motorola Solutions will have no liability with respect to any claim of patent infringement which is based upon the combination of the Product or parts furnished hereunder with software, apparatus or devices not furnished by Motorola Solutions, nor will Motorola Solutions have any liability for the use of ancillary equipment or software not furnished by Motorola Solutions which is attached to or used in connection with the Product. The foregoing states the entire liability of Motorola Solutions with respect to infringement of patents by the Product or any parts thereof.

Laws in the United States and other countries preserve for Motorola Solutions certain exclusive rights for copyrighted Motorola Solutions software such as the exclusive rights to reproduce in copies and distribute copies of such Motorola Solutions software. Motorola Solutions software may be used in only the Product in which the software was originally embodied and such software in such Product may not be replaced, copied, distributed, modified in any way, or used to produce any derivative thereof. No other use including, without limitation, alteration, modification, reproduction, distribution, or reverse engineering of such Motorola Solutions software or exercise of rights in such Motorola Solutions software is permitted. No license is granted by implication, estoppel or otherwise under Motorola Solutions patent rights or copyrights.

VII. Governing Law

This Warranty is governed by the laws of the State of Illinois, USA.

Chapter 1

Introduction

1.1

Radio Description

The radios are available in the following frequency ranges and power levels.

Table 1: Radio Frequency Ranges and Power Levels

Frequency Band	Bandwidth	Power Level
VHF	136-174 MHz	1–25 W 25–45 W
UHF1	403–470 MHz	1–25 W 25–40 W
UHF2	450–512 MHz	1–40 W
800/900 Band	806–870 MHz 896–941 MHz	10–35 W 10–30 W

These digital radios are among the most sophisticated two-way radios available. They have a robust design for radio users who need high performance, quality, and reliability in their daily communications. This architecture provides the capability of supporting a multitude of legacy and advanced features resulting in a more cost-effective two-way radio communications solution.

1.2

Summary of Printed Circuit Boards and Bands Available

The following table lists all the bands available in this manual and the revision of the Printed Circuit Boards used. For details, refer to the respective chapters.

Description	PC Board Part Number	Board Revision
Numeric Display Control Head	84012212002	B
Color Display Control Head	84012211002	B
VHF Low Power Service Information	84012734001	A
	84012734002	B
VHF High Power Service Information	84012736001	A
	84012736002	B
UHF1 Low Power Service Information	84012735001	A
	84012735003	C
UHF1 High Power Service Information	84012737001	A

Description	PC Board Part Number	Board Revision
	84012737003	C
UHF2 Service Information	84012728001	A
	84012728003	C
800/900 Band Service Information	84012657001	A
Bluetooth/Wi-Fi/GNSS Expansion Board Service Information	PC000942A01	AA
Generic Option Board (GOB) Service Information	PC000957A01	CA

Chapter 2

Maintenance

This chapter provides information about the care and maintenance of this radio.

- Preventive maintenance such as inspection and cleaning.
- Safe handling of Complementary Metal Oxide Semiconductor (CMOS) and Laterally Diffused Metal Oxide Semiconductor (LDMOS) devices.
- Repair procedures and techniques.
- Pre-baking of Integrated Circuits



CAUTION: Only Motorola Solutions Service Centers or Authorized Motorola Solutions Service Dealers can perform this function.

2.1

Preventive Maintenance

Periodic visual inspection and cleaning is recommended.

2.1.1

Inspection

Check that the external surfaces of the radio are clean, and that all external controls and switches are functional. It is not recommended to inspect the interior electronic circuitry.

2.1.2

Cleaning Procedures

The following procedures describe the recommended cleaning agents and the methods to be used when cleaning the external and internal surfaces of the radio.

External surfaces include the front cover, housing assembly, and battery case. These surfaces should be cleaned whenever a periodic visual inspection reveals the presence of smudges, grease, and/or grime.



NOTICE:

Internal surfaces should be cleaned only when the radio is disassembled for service or repair.

The only recommended agent for cleaning the external radio surfaces is a 0.5% solution of a mild dishwashing detergent in water. The only factory recommended liquid for cleaning the printed circuit boards and their components is isopropyl alcohol (100% by volume).



CAUTION: Use all chemicals as prescribed by the manufacturer. Be sure to follow all safety precautions as defined on the label or material safety data sheet.

The effects of certain chemicals and their vapors can have harmful results on certain plastics. Avoid using aerosol sprays, tuner cleaners and other chemicals.

Cleaning External Plastic Surfaces

Apply the 0.5% detergent-water solution sparingly with a stiff, non-metallic, short-bristled brush to work all loose dirt away from the radio. Use a soft, absorbent, lintless cloth or tissue to remove the solution and dry the radio. Make sure that no water remains entrapped near the connectors, cracks, or crevices.

Cleaning Internal Circuit Boards and Components

Isopropyl alcohol (100%) may be applied with a stiff, non-metallic, short-bristled brush to dislodge embedded or caked materials located in hard-to-reach areas. The brush stroke should direct the dislodged material out and away from the inside of the radio. Make sure that controls or tunable components are not soaked with alcohol. Do not use high-pressure air to hasten the drying process since this could cause the liquid to collect in unwanted places. After completing the cleaning process, use a soft, absorbent, lintless cloth to dry the area. Do not brush or apply any isopropyl alcohol to the frame, control head and housing assembly.



NOTICE: Always use a fresh supply of alcohol and a clean container to prevent contamination by dissolved material (from previous usage).

2.1.3

Safe Handling of CMOS and LDMOS Devices

Complementary Metal Oxide Semiconductor (CMOS) and Laterally Diffused Metal Oxide Semiconductor (LDMOS) devices are used in this family of radios, and are susceptible to damage by electrostatic or high-voltage charges.

Damage can be latent, resulting in failures occurring weeks or months later. Therefore, special precautions must be taken to prevent device damage during disassembly, troubleshooting, and repair.

Handling precautions are mandatory for CMOS/LDMOS circuits and are especially important in low humidity conditions. Do not attempt to disassemble your radio without referring to the following caution statement.



CAUTION:

This radio contains static-sensitive devices. Do not open your radio unless you are properly grounded. Take the following precautions when working on this unit:

- Store and transport all CMOS/LDMOS devices in conductive material so that all exposed leads are shorted together. Do not insert CMOS/LDMOS devices into conventional plastic "snow" trays used for storage and transportation of other semiconductor devices.
- Ground the working surface of the service bench to protect the CMOS/LDMOS device. It is recommended that you use a wrist strap, two ground cords, a table mat, a floor mat, electrostatic discharge (ESD) shoes, and an ESD chair.
- Wear a conductive wrist strap in series with a 100k resistor to ground. Replacement wrist straps that connect to the bench top covering are Motorola Solutions part number 4280385A59.
- Do not wear nylon clothing while handling CMOS/LDMOS devices.
- Do not insert or remove CMOS/LDMOS devices with power applied. Check all power supplies used for testing CMOS/LDMOS devices to be certain that there are no voltage transients present.
- When straightening CMOS/LDMOS pins, provide ground straps for the apparatus used.
- When soldering, use a grounded soldering iron.
- Handle CMOS/LDMOS devices by the package and not by the leads. Before touching the unit, touch an electrical ground to remove any static charge that you may have accumulated. The package and substrate may be electrically common. If so, the reaction of a discharge to the case would cause the same damage as touching the leads.

2.2

General Repair Procedures and Techniques

Environmentally Preferred Products (EPP) were developed and assembled using environmentally preferred components and solder assembly techniques to comply with the European

Union's Restriction of Hazardous Substances (ROHS 2) Directive 2011/65/EU and Waste Electrical and Electronic Equipment (WEEE) Directive 2012/19/EU. To maintain product compliance and reliability, use only the Motorola Solutions specified parts in this manual.

For the identification of lead (Pb) free assemblies, all EPP products carry the EPP Marking, shown in the following examples, on the Printed Circuit Board (PCB). This marking provides information to those performing assembly, servicing, and recycling operation on this product, adhering to the JEDEC Standard No. 97. The EPP Marking takes the form of a label or marking on the PCB.

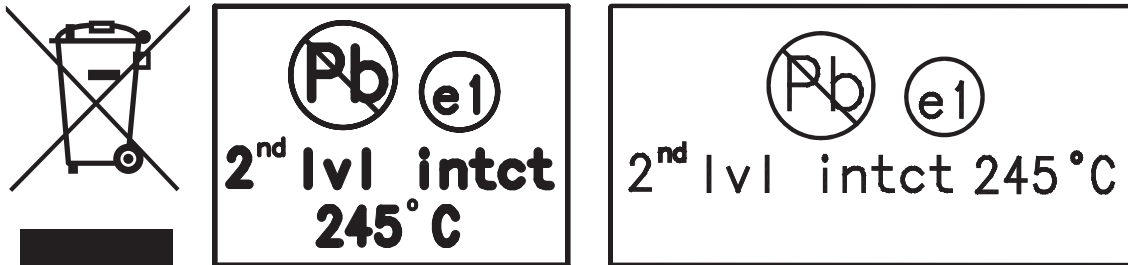

Any rework or repair on Environmentally Preferred Products must be done using the appropriate lead-free solder wire and lead-free solder paste as stated in the following tables:

Table 2: Lead Free Solder Wire Part Number List

Motorola Solutions Part Number	Alloy	Flux Type	Flux Content by Weight	Melting Point	Supplier Part number	Diameter	Weight
1088929Y01	95.5Sn/3.8Ag/0.7Cu	RMA Version	2.7–3.2%	217 °C	52171	0.015 in.	1 lb spool

Table 3: Lead Free Solder Paste Part Number List

Manufacturer Part Number	Viscosity	Type	Composition and Percent Metal	Liquid Temperature
NC-SMQ230	900–1000KCPs Brookfield (5 rpm)	Type 3 (-325/+500)	(95.5%Sn-3.8%Ag-0.7%Cu) 89.3%	217 °C

Parts Replacement and Substitution

When damaged parts are replaced, identical parts must be used. If the identical replacement part is not locally available, check the parts list for the proper Motorola Solutions part number and order the part.

Rigid Circuit Boards

This family of radios use bonded, multi-layer, printed circuit boards. Since the inner layers are not accessible, some special considerations are required when soldering and unsoldering components. The plated-through holes may interconnect multiple layers of the printed circuit. Therefore, exercise care to avoid pulling the plated circuit out of the hole.

When soldering near a connector:

- Avoid accidentally getting solder in the connector.
- Be careful not to form solder bridges between the connector pins.
- Examine your work closely for shorts due to solder bridges.

For soldering components with Hot-Air or infra red solder systems, check the user guide of your solder system to get information on solder temperature and time for the different housings of the integrated circuits and other components.

2.3

Pre-baking of Integrated Circuits

Electronic components are generally coated with plastic material which has the nature of not being waterproof. If kept unsealed, the components can absorb humidity.

When soldered to the board (especially with reflow techniques) the sudden change in temperature can cause fissures or cracks that can result in malfunction or damage. Therefore service should temper in a Desiccant Cabinet (12 hours at 50 °C) the radio PCB before heating up areas around Moisture Sensitive (MS) components.

To avoid this problem, these Moisture Sensitive (MS) components must be stored and shipped in a sealed wrapping (dry pack). Processing must take place only with dry components when uninterrupted dry storage can be guaranteed, otherwise the components must be pre-baked.

If a reflow procedure takes place close to MS components, the whole board must be pre-baked.

Table 4: MS Components and Location

Location	Circuit Ref.	Motorola Solutions Part No.	MSL
Numeric Display Control Head	D6001	4815809H02	2
Numeric Display Control Head	D6000 D6004	4815809H04	2
Colour Display Control Head	D6400 D6401		
Numeric Display Control Head	D6003 D6005	48012173001	2a
Colour Display Control Head	D6404 D6405 D6406		
Colour Display Control Head	U6400		
Colour Display Control Head	D6403	4815809H03	2
Colour Display Control Head	D6404	5171774H01	3
GOB	U5102	IC000643A01	3
GOB	U5103	51012009003	3
Controller	U1001M1	51012295001	3
Controller	U3103M1	51012142001	2
Controller	U3104M1	5171590Y73	2
Controller	U3105M1	5114610F01	2
Controller	U3108M1	51012138001	3
Controller	U3200M1	51009415001	3

Location	Circuit Ref.	Motorola Solutions Part No.	MSL
Controller	U3204M1	51009509001	3
VHF 1–25 W VHF 25–45 W	Q0702M5	48012067002	3
UHF1 1–25 W UHF1 25–40 W	Q0705M5	48012067002	3
VHF 1–25 W VHF 25–45 W UHF2 1–40 W 8/900 10–35/30 W	Q0705M6	48012022001	3
VHF 1–25 W VHF 25–45 W UHF1 1–25 W UHF1 25–40 W UHF2 1–40 W 8/900 10–35/30 W	U0000M2	51009277001	3

2.4

IPC/JEDEC J-STD-020D.1 (March 2008) Chart

Table 5: Moisture Sensitivity Levels

Level	Floor Life		Soak Requirements				
			Standard		Accelerated Equivalent		
					eV 0.40– 0.48	eV 0.30– 0.39	Condi- tion
Time (hours)	Condi- tion	Time (hours)	Condi- tion	Time (hours)	Time (hours)		
1	Unlimit- ed	≤30 °C/ 85% RH	168 +5/-0	85 °C/ 85% RH	NA	NA	NA
2	1 year	≤30 °C/ 60% RH	168 +5/-0	85 °C/ 60% RH	NA	NA	NA
2a	4 weeks	≤30 °C/ 60% RH	696 ² +5/-0	30 °C/ 60% RH	120 +1/-0	168 +1/-0	60 °C/ 60% RH
3	168 hours	≤30 °C/ 60% RH	192 ² +5/-0	30 °C/ 60% RH	40 +1/-0	52 +1/-0	60 °C/ 60% RH

Level	Floor Life		Soak Requirements				
			Standard		Accelerated Equivalent		
	Time (hours)	Condi- tion			Time (hours)	Condi- tion	eV 0.40– 0.48
4	72 hours	≤30 °C/ 60% RH	96 ² +2/-0	30 °C/ 60% RH	20 +5/-0	24 +0.5/-0	60 °C/ 60% RH
5	48 hours	≤30 °C/ 60% RH	72 ² +2/-0	30 °C/ 60% RH	15 +5/-0	20 +0.5/-0	60 °C/ 60% RH
5a	24 hours	≤30 °C/ 60% RH	48 ² +2/-0	30 °C/ 60% RH	10 +0.5/-0	13 +0.5/-0	60 °C/ 60% RH
6	Time on Label (TOL)	≤30 °C/ 60% RH	TOL	30 °C/ 60% RH	NA	NA	NA



CAUTION:

- 1 To use the "accelerated equivalent" soak conditions, correlation of damage response (including electrical, after soak and reflow), should be established with the "standard" soak conditions. Alternatively, if the known activation energy for moisture diffusion of the package materials is in the range of 0.40–0.48 eV or 0.30–0.39 eV, the "accelerated equivalent" may be used. Accelerated soak times may vary due to material properties (for example, mold compound, encapsulant, etc.). JEDEC document JESD22-A120 provides a method for determining the diffusion coefficient.
- 2 The standard soak time includes a default value of 24 hours for semiconductor Manufacturer's Exposure Time (MET) between bake and bag and includes the maximum time allowed out of the bag at the distributor's facility.
 If the actual MET is less than 24 hours, the soak time may be reduced. For soak conditions of 30 °C/60% RH, the soak time is reduced by one hour for each hour the MET is less than 24 hours. For soak conditions of 60 °C/60% RH, the soak time is reduced by one hour for each five hours the MET is less than 24 hours.
 If the actual MET is greater than 24 hours the soak time must be increased. If soak conditions are 30 °C/60% RH, the soak time is increased one hour for each hour that the actual MET exceeds 24 hours. If soak conditions are 60 °C/60% RH, the soak time is increased one hour for each five hours that the actual MET exceeds 24 hours.
- 3 Supplier may extend the soak times at their own risk.

Chapter 3

Test Equipment and Service Aids

This chapter lists the recommended test equipment and service aids, as well as information on field programming equipment that can be used in servicing and programming Motorola Solutions radios.

3.1

Recommended Test Equipment

The list of equipment contained in the following table includes most of the standard test equipment required.

Table 6: Test Equipments

Equipment	Characteristics	Example	Application
Service Monitor	Can be used as a substitute.	Aeroflex 3920 (www.aeroflex.com) or equivalent	Frequency/deviation meter and signal generator for wide-range troubleshooting and alignment.
Digital RMS Multimeter ¹	100 μ V to 300 V	Fluke 179 (www.fluke.com) or equivalent	AC/DC voltage and current measurements. Audio voltage measurements.
	5 Hz to 1 MHz		
	10 M Ω Impedance		
RF Signal Generator ¹	100 MHz to 1 GHz	Agilent N5181A (www.agilent.com), Ramsey RSG1000B (www.ramsey-electronics.com), or equivalent	Receiver measurements
	-130 dBm to +10 dBm		
	FM Modulation: 0 kHz to 10 kHz		
	Audio Frequency: 100 Hz to 10 kHz		
Oscilloscope ¹	2 Channel	Tektronix TDS1001b (www.tektronix.com) or equivalent	Waveform measurements
	50 MHz Bandwidth		
	5 mV/div to 20 V/div		
Power Meter and Sensor ¹	5% Accuracy	Bird 43 ThruLine Watt Meter (www.bird-electronic.com) or equivalent	Transmitter power output measurements
	100 MHz to 500 MHz		
	50 W		
RF Millivoltmeter	100 mV to 3 V RF	Boonton 92EA (www.boonton.com) or equivalent	RF level measurements
	10 kHz to 1 GHz		
Power Supply	0 V to 32 V	B&K Precision 1790 (www.bkprecision.com) or equivalent	Voltage supply
	0 A to 20 A		

¹ Can use Service Monitor as substitute.

3.2

Service Aids

The following table lists the service aids recommended for working on the radio. While all of these items are available from Motorola Solutions, most are standard workshop equipment items, and any equivalent item capable of the same performance may be substituted for the item listed.

Table 7: Service Aids

Motorola Solutions Part No.	Description	Application
RLN4460_	Test Box	Enables connection to audio/accessory jack. Allows switching for radio testing.
RVN5115_	Customer Programming Software on CD-ROM	Allows servicer to program radio parameters, tune and troubleshoot radios.
PMKN4010_	Mobile and Repeater Rear Programming Cable	Connects the radio rear connector to a USB port for radio programming and data applications.
PMKN4016_	Mobile and Repeater Rear Accessory Programming and Test Cable	Connects the radio rear connector to a USB port for radio programming, data applications, testing, and alignment.
PMKN4018_	Mobile and Repeater Rear Accessory Connector Universal Cable	Connects the radio rear connector to accessory devices such as desk sets. Cable contains all 26 wires and is unterminated at the user end.
HKN6184_	Mobile Front Programming Cable	Connects the radio front connector to a USB port for radio programming and data applications.
HPN4007_	Power Supply	Provides the radio with power when bench testing.
PMEN4027_	Housing Eliminator	Test Fixture used to bench test the radio PCB.
6686119B01	Control Head Dismantling Tool	Assists in the removal of radio control head.
66012025001	Volume/Channel Knob Removal Tool	Assists in the removal of the Volume/Channel knob.
66012020001	RFIC (U0000) Repair Stencil	Fixture to screen solder paste onto the IC leads for replacement.

3.3

Programming Cables

Figure 1: Mobile Front Programming Cable HKN6184_



Figure 2: Mobile & Repeater Rear Programming Cable PMKN4010_

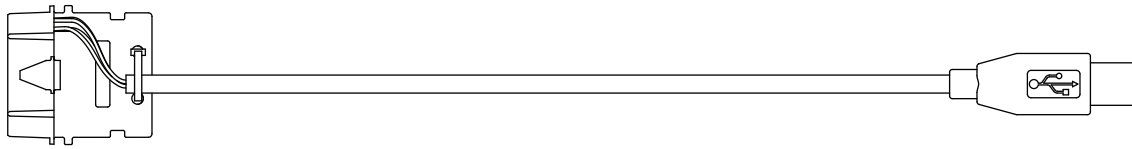
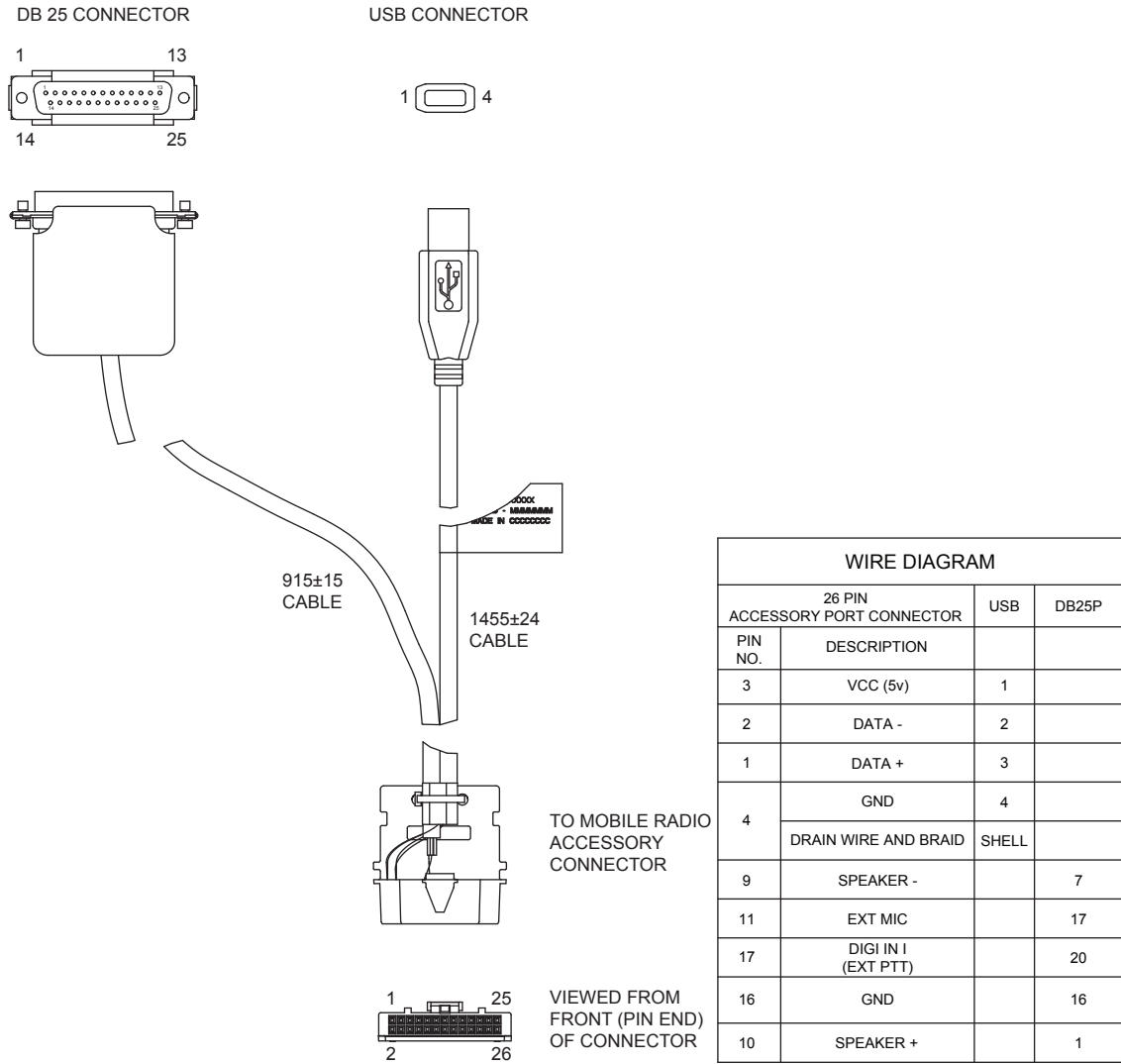

Figure 3: Mobile & Repeater Rear Accessory Programming and Test Cable PMKN4016_



Chapter 4

Power Up Self-Test

This topic describes Power-Up Error Codes and Operational Codes.

4.1

Power-Up Error Codes

When the radio is turned on (powered-up), the radio performs cursory tests to determine if its basic electronics and software are in working order.

Problems detected during these tests are presented as error codes on the radio display. The presence of an error should prompt the user that a problem exists and that a service technician should be contacted.

Self-test errors are classified as either fatal or non-fatal. Fatal errors inhibit user operation; non-fatal errors do not. Use the following table to aid in understanding particular power-up error code displays.

Table 8: Power-Up Error Codes

Error Code	Description	Error Type	Corrective Action
ERROR 01/02	FLASH ROM Codeplug Checksum	Non-Fatal	Reprogram the codeplug.
ERROR 01/22	Tuning Codeplug Checksum	Non-Fatal	Reprogram the tuning partition.
FAIL 01/82	FLASH ROM Codeplug Checksum	Fatal	Reprogram the codeplug.
FAIL 01/90	General Hardware Error	Fatal	Turn the radio off, then on. If problem persists, send radio to the nearest Motorola Solutions Depot.
FAIL 01/92	Security Partition Checksum	Fatal	Reprogram the security partition/codeplug.
FAIL 01/93	FlashPORT AUTHENT CODE Failure	Fatal	Contact the depot.
FAIL 01/A2	Tuning Codeplug Checksum	Fatal	Reprogram the tuning partition/codeplug.
FAIL 02/90	RF Hardware Error	Fatal	Send radio to the nearest Motorola Solutions Depot.

Chapter 5

Control Head Service Information

5.1

Numeric Display Model

The Control Head contains the internal speaker, the On/Off button, the Volume/Channel knob, the microphone connector, several buttons to operate the radio and several indicator Light Emitting Diodes (LED) to inform the user about the radio status and channel. The switches and indicators on the Control Head are indirectly controlled by the processor in the radio.

Figure 4: Numeric Display Model (PMLN7500_)



5.2

Color Display Model

The Control Head contains the internal speaker, the On/Off button, the Volume/Channel knob, the microphone connector, several buttons to operate the radio, several indicator Light Emitting Diodes (LED) to inform the user about the radio status, and a Color Liquid Crystal Display (LCD) for alphanumeric information, for example, channel number or call address name. The switches, indicators, and LCD on the Control Head are indirectly controlled by the processor in the radio.

Figure 5: Color Display Model (PMLN7501_)



Chapter 6

Mobile Radio Block Diagram

This block diagram must be used as reference for all subsequent chapters.

Figure 6: Top Level Block Diagram for PCB No. PC000942A01-AA

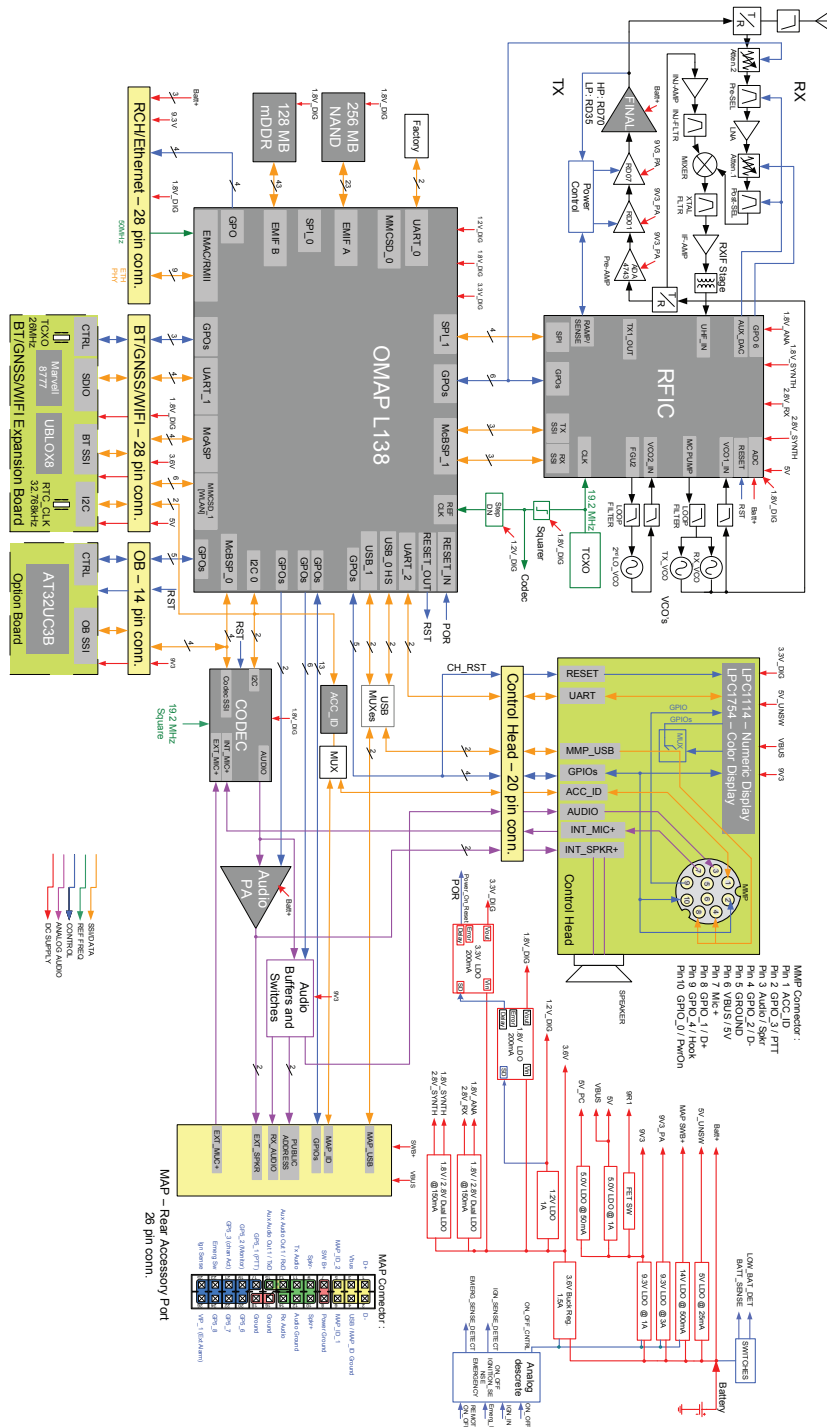

Chapter 7

Troubleshooting Charts

7.1 Troubleshooting Charts for Control Head

7.1.1 Numeric Display Model Control Head (PMLN7500_)

Figure 7: Troubleshooting Flow Chart for On/Off

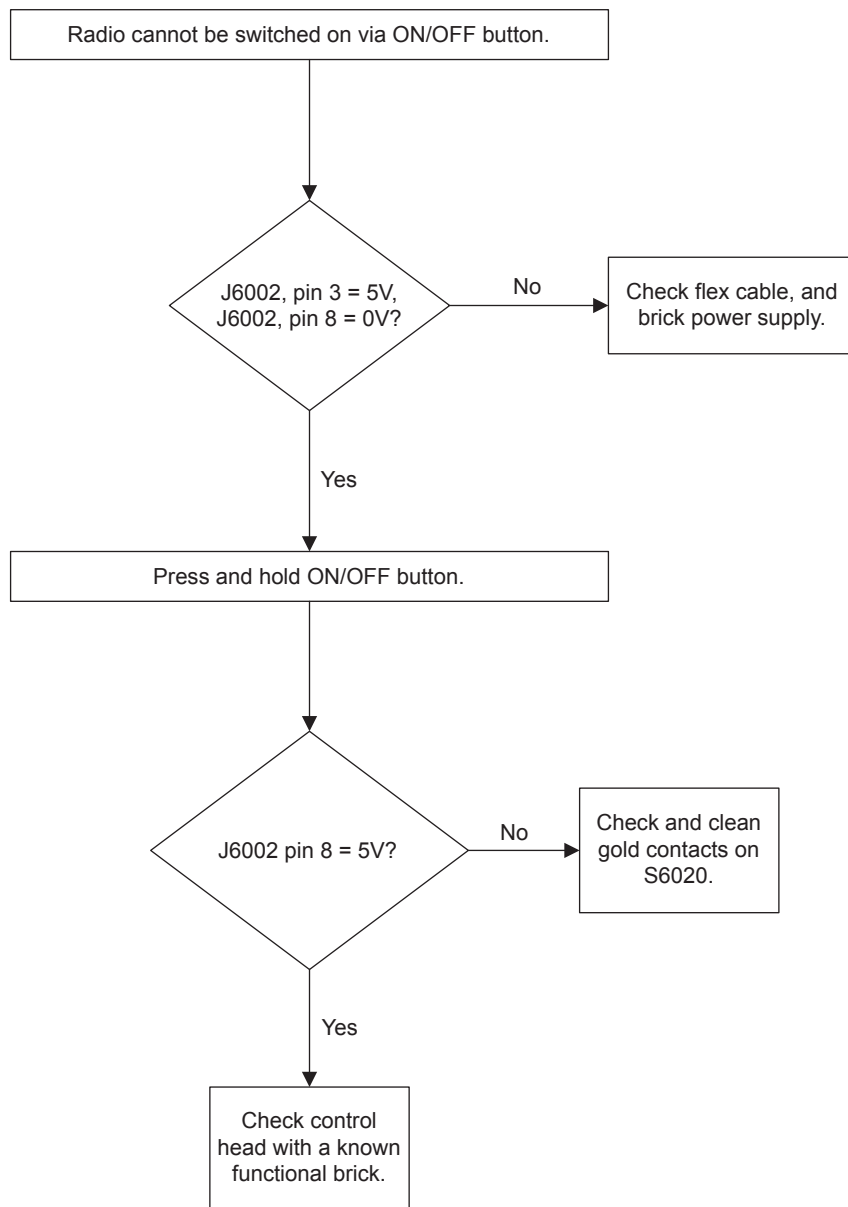

7.1.2
Color Display Model Control Head (PMLN7501_)

Figure 8: Troubleshooting Flow Chart for On/Off

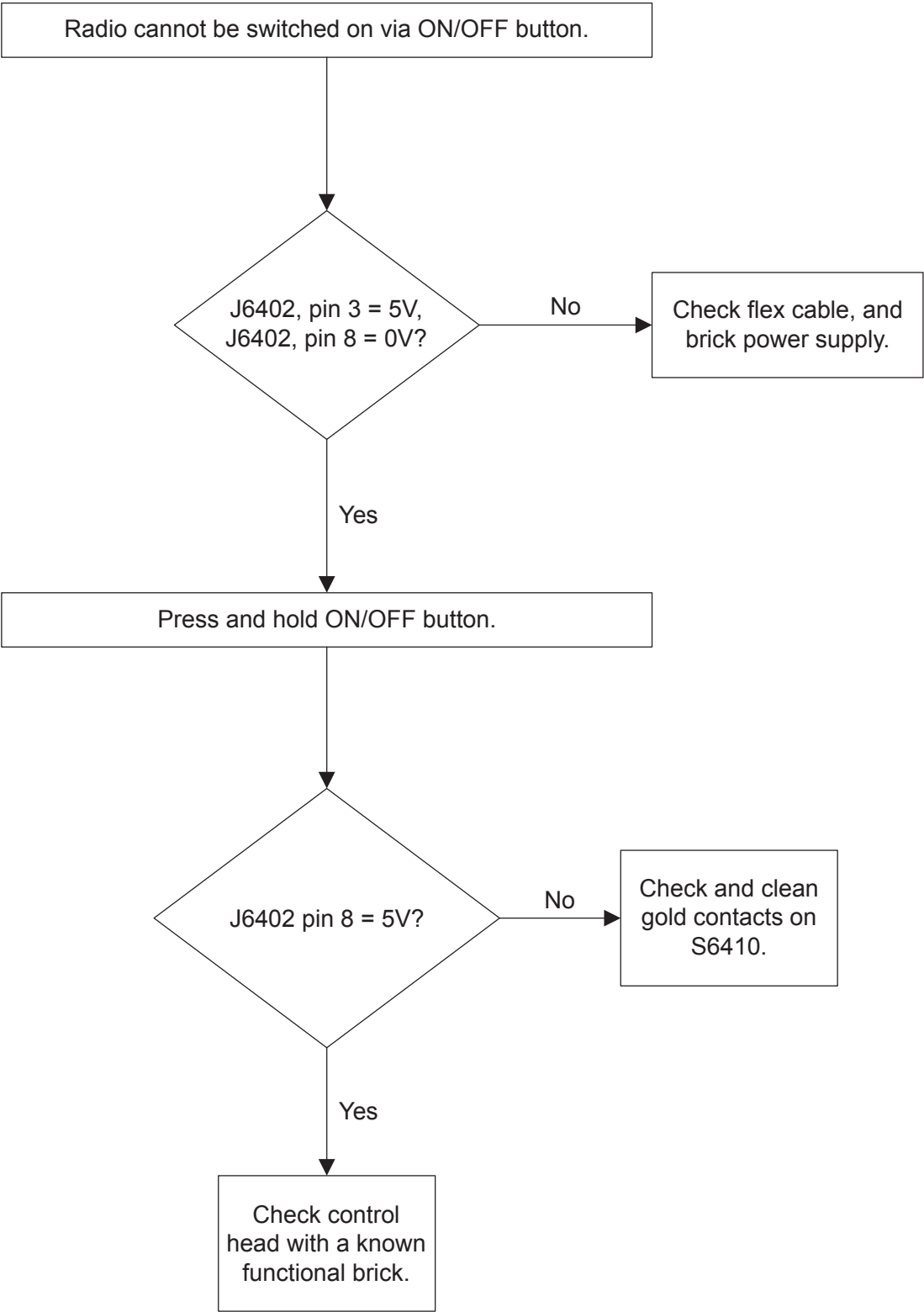

Figure 9: Troubleshooting Flow Chart for Display

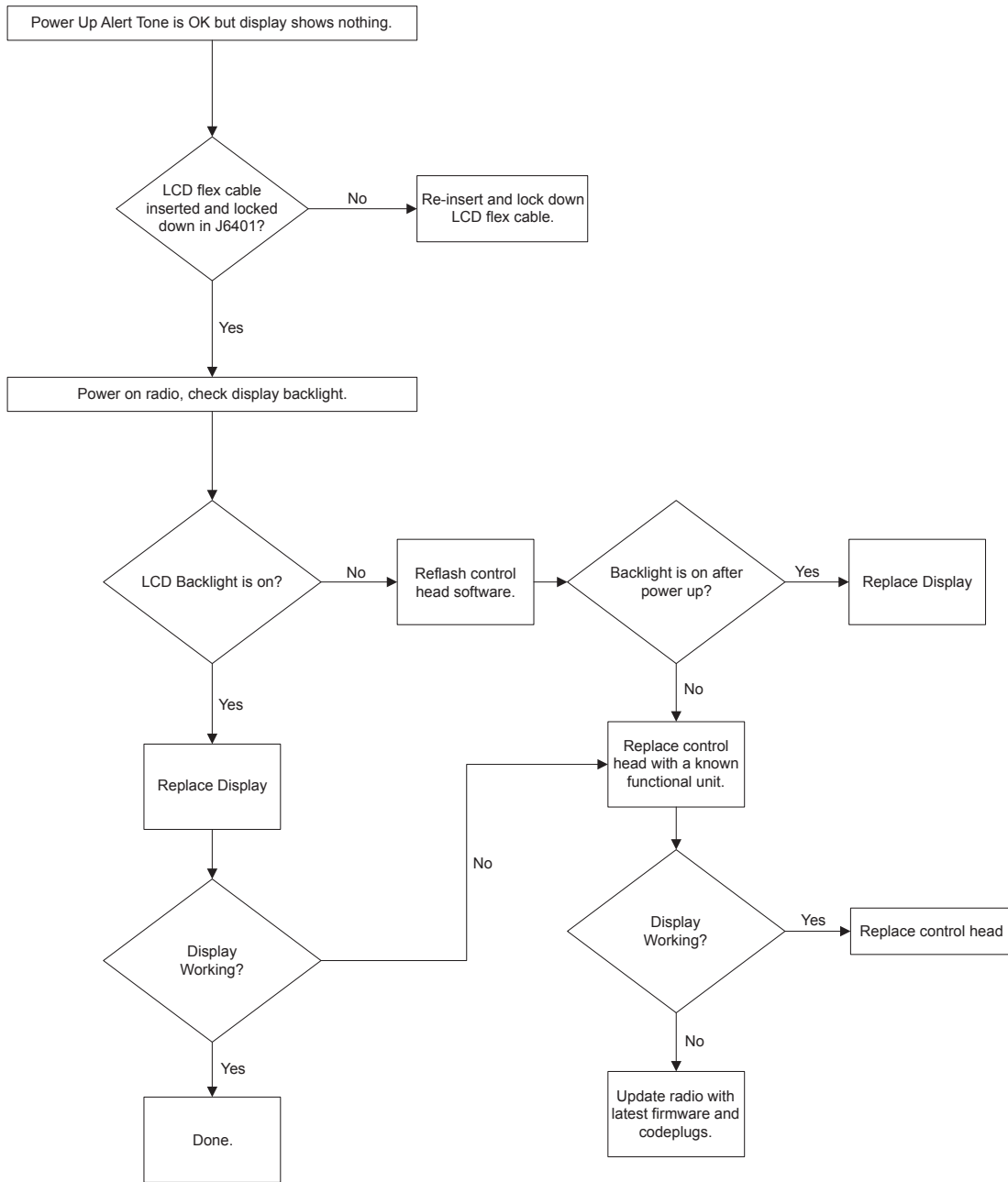
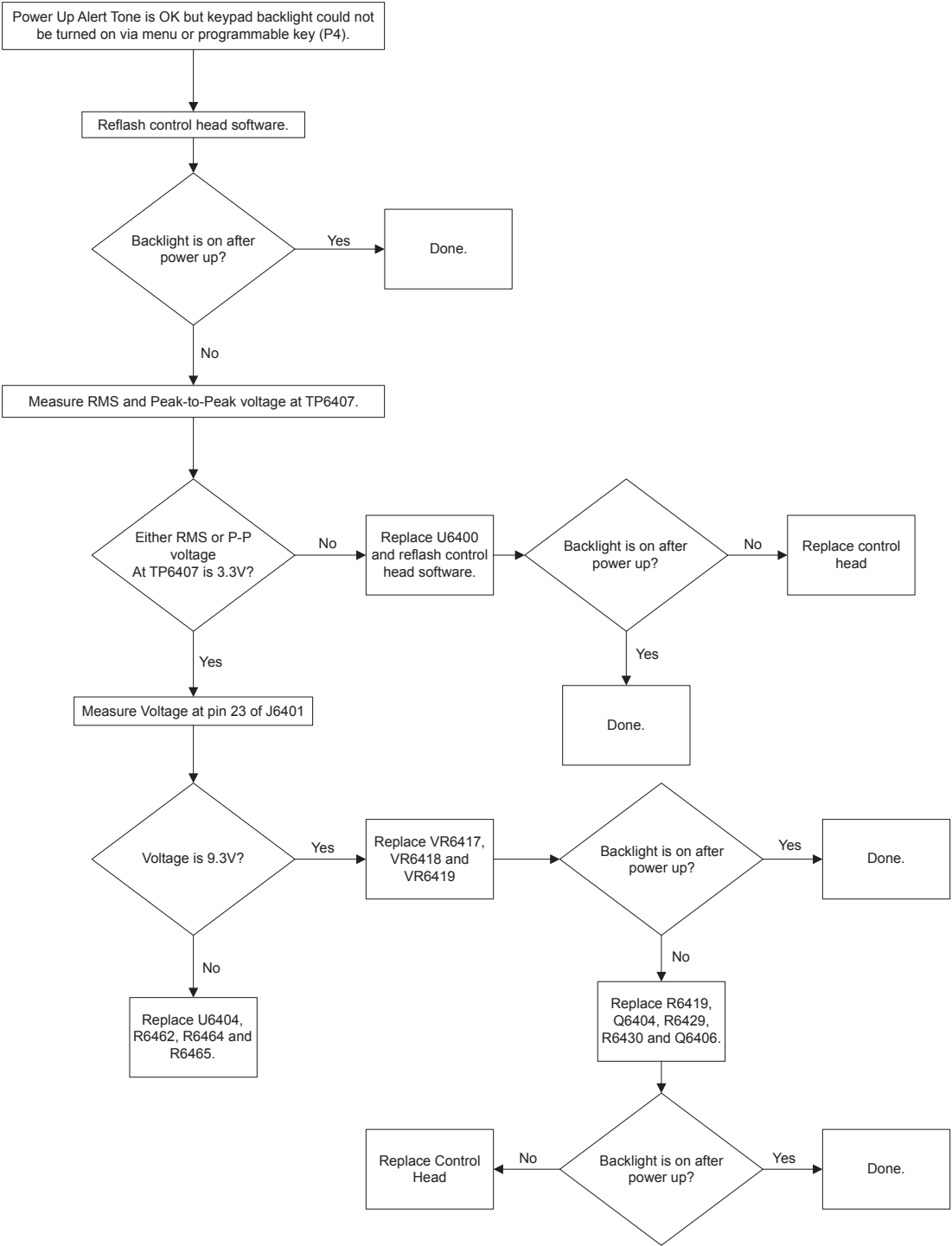

Figure 10: Troubleshooting Flow Chart for Backlight



7.2 Troubleshooting Charts for Controller

Figure 11: Troubleshooting Chart for Controller

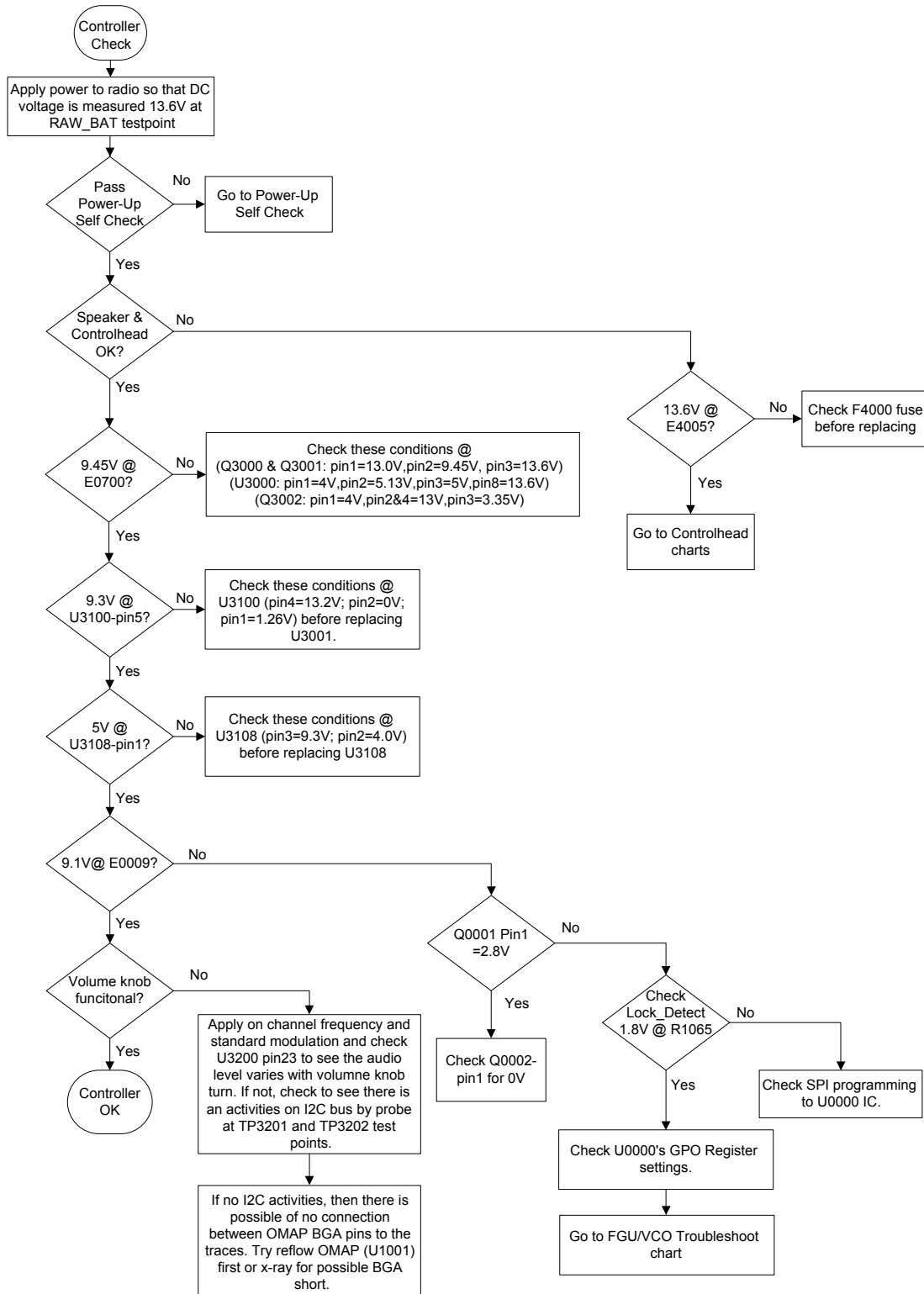

Figure 12: Troubleshooting Chart for Power-Up

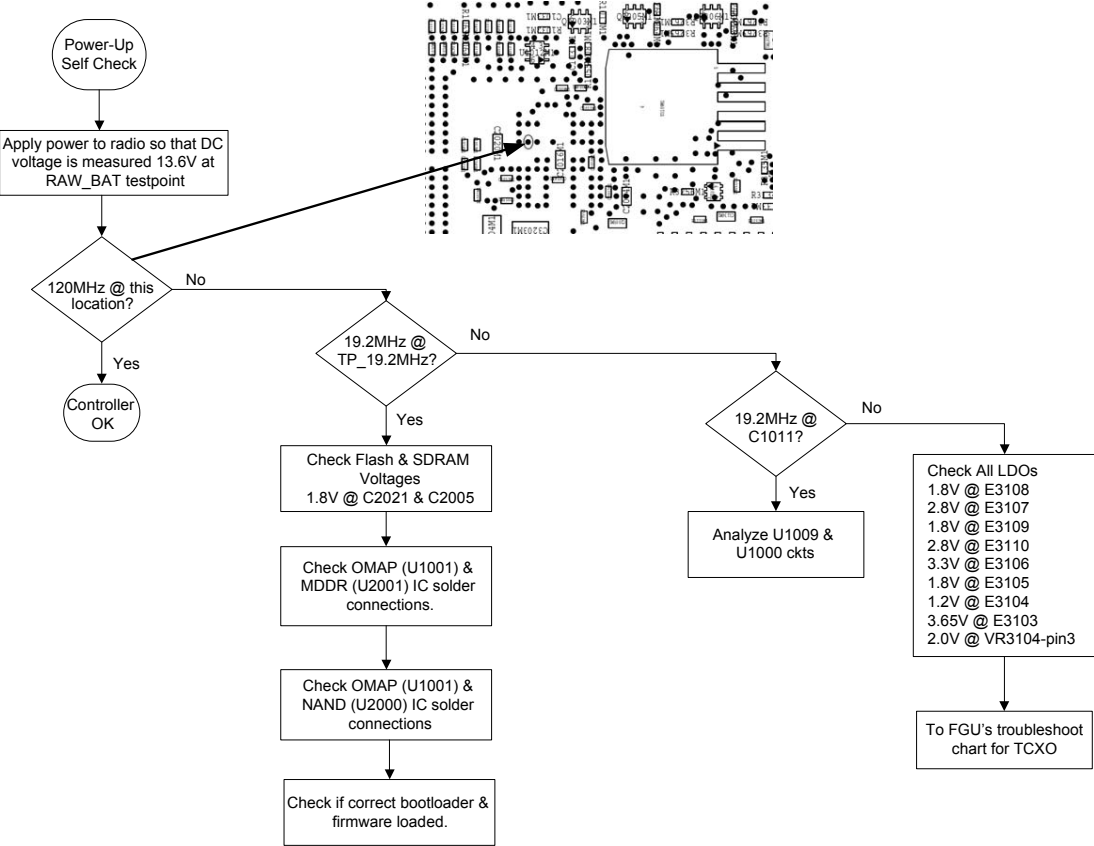

Figure 13: Troubleshooting Chart for MAP USB (Device Mode)

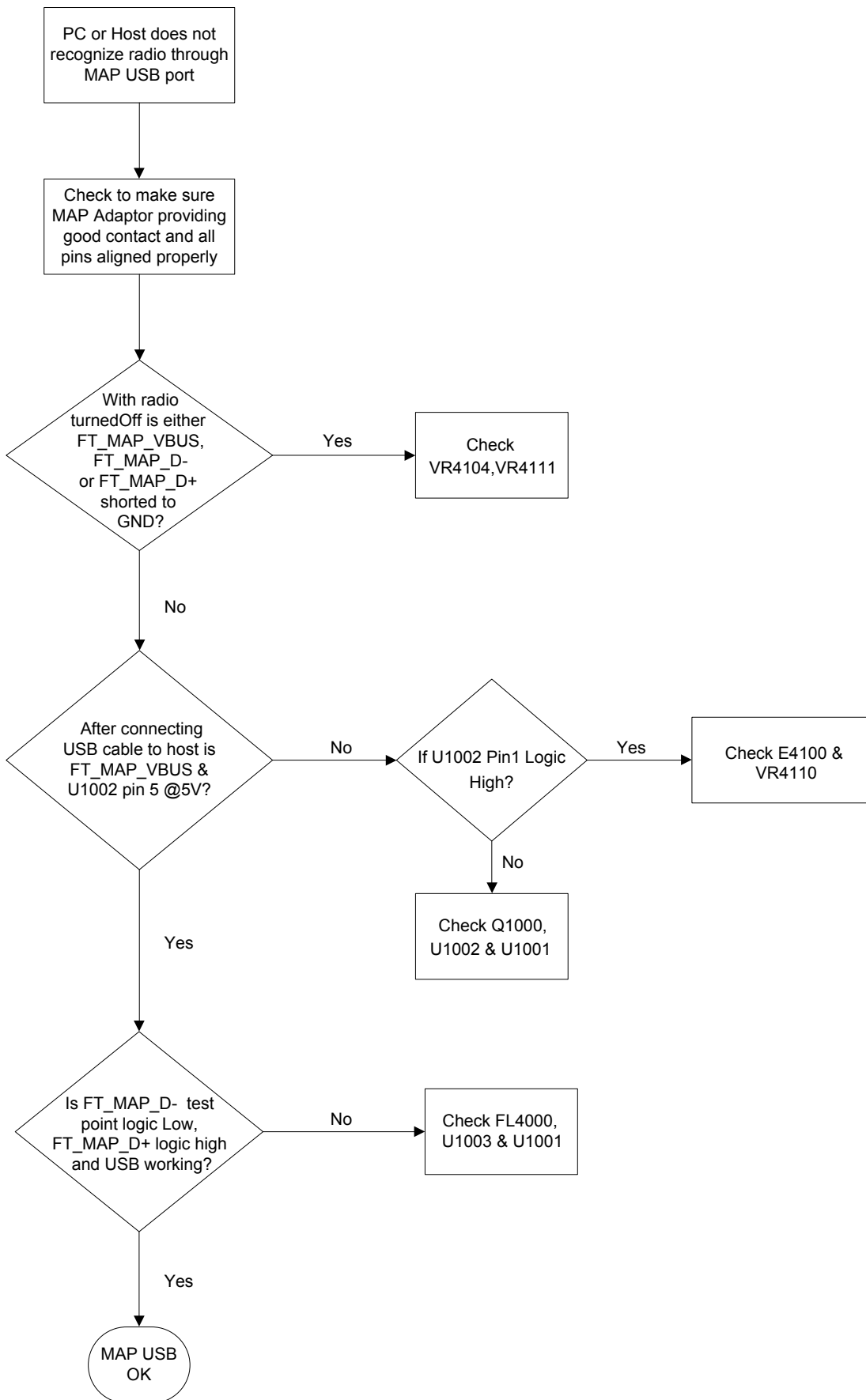

Figure 14: Troubleshooting Chart for MMP USB (Device Mode)

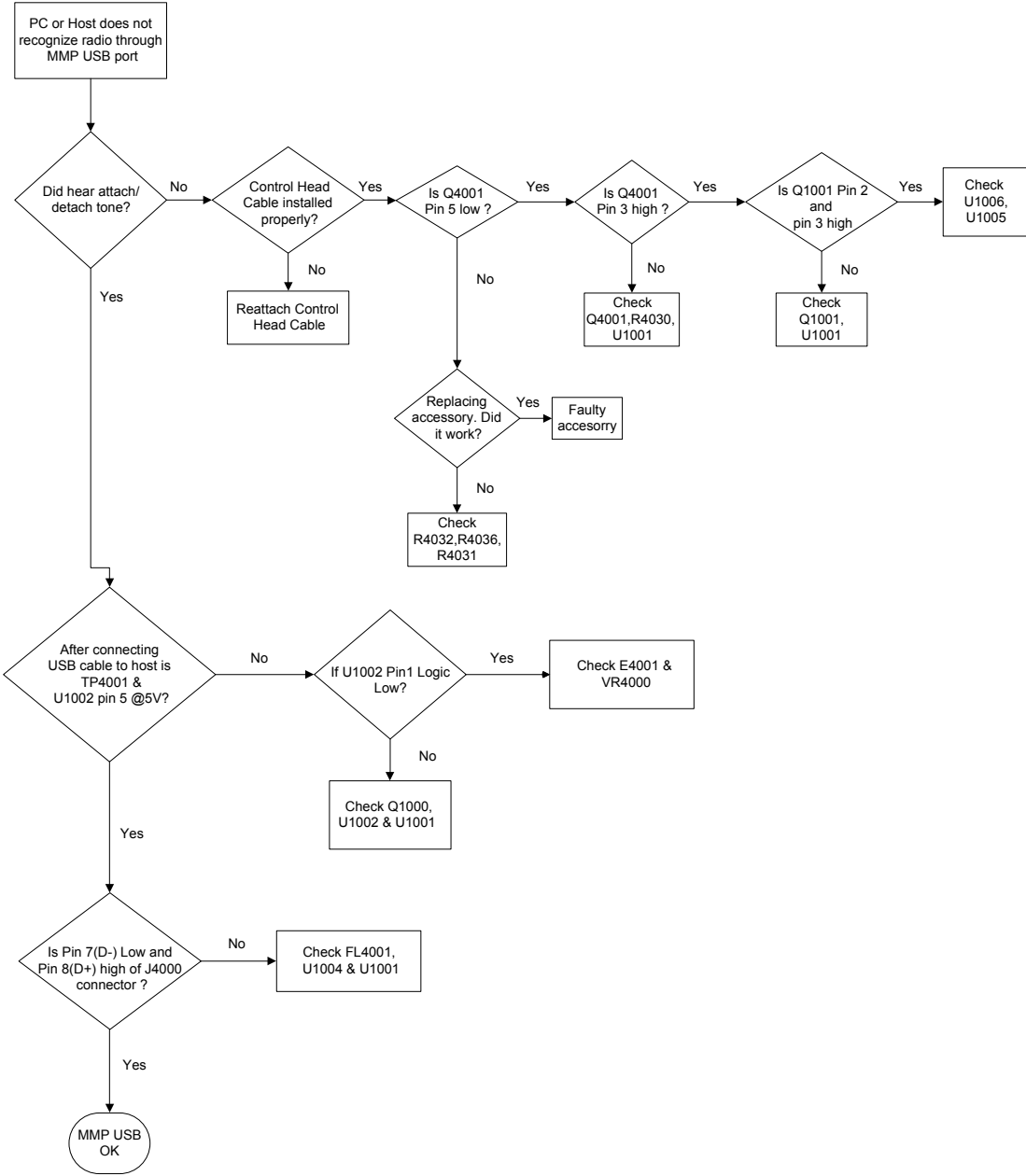

Figure 15: Troubleshooting Chart for MMP USB (Host Mode)

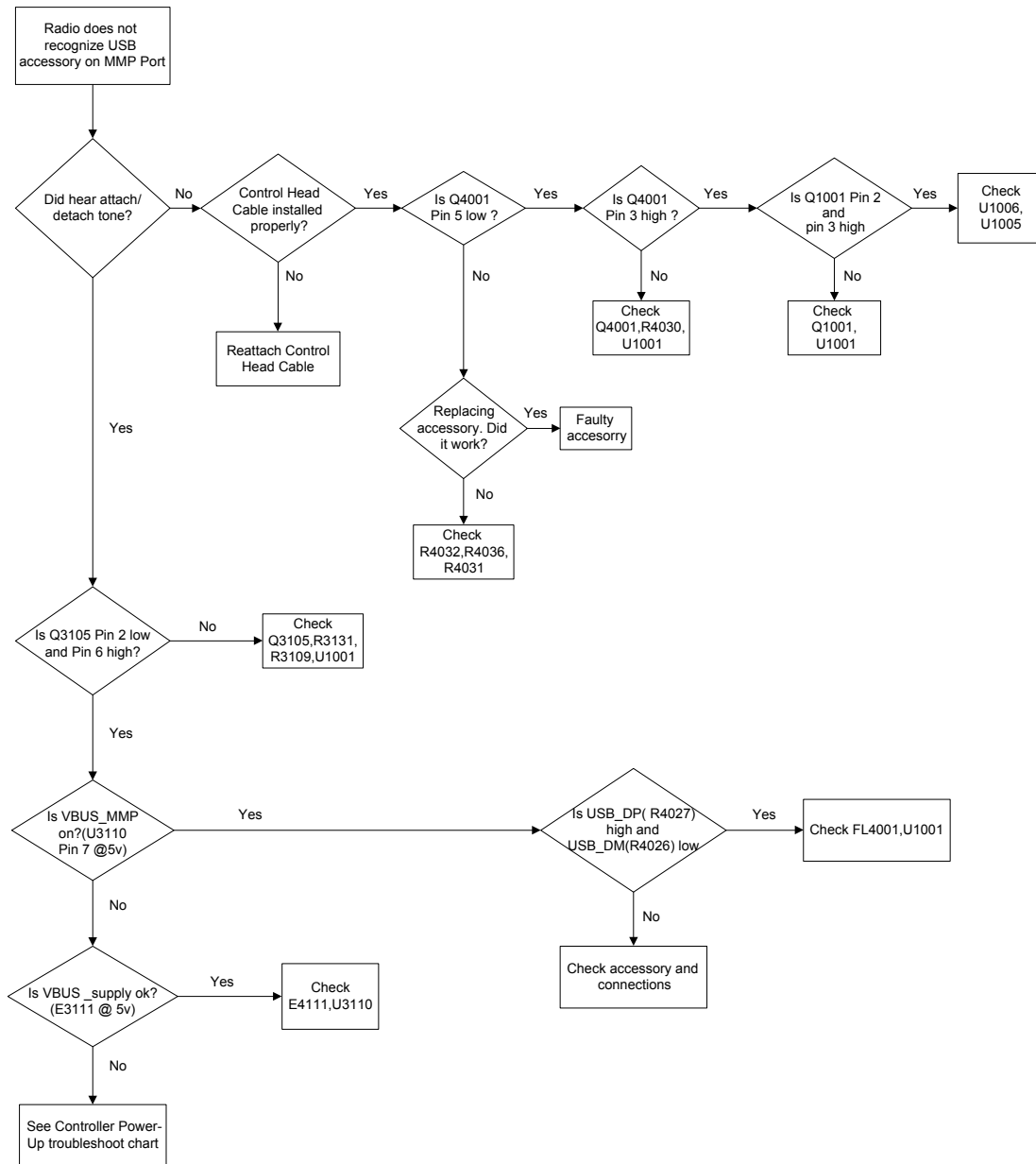
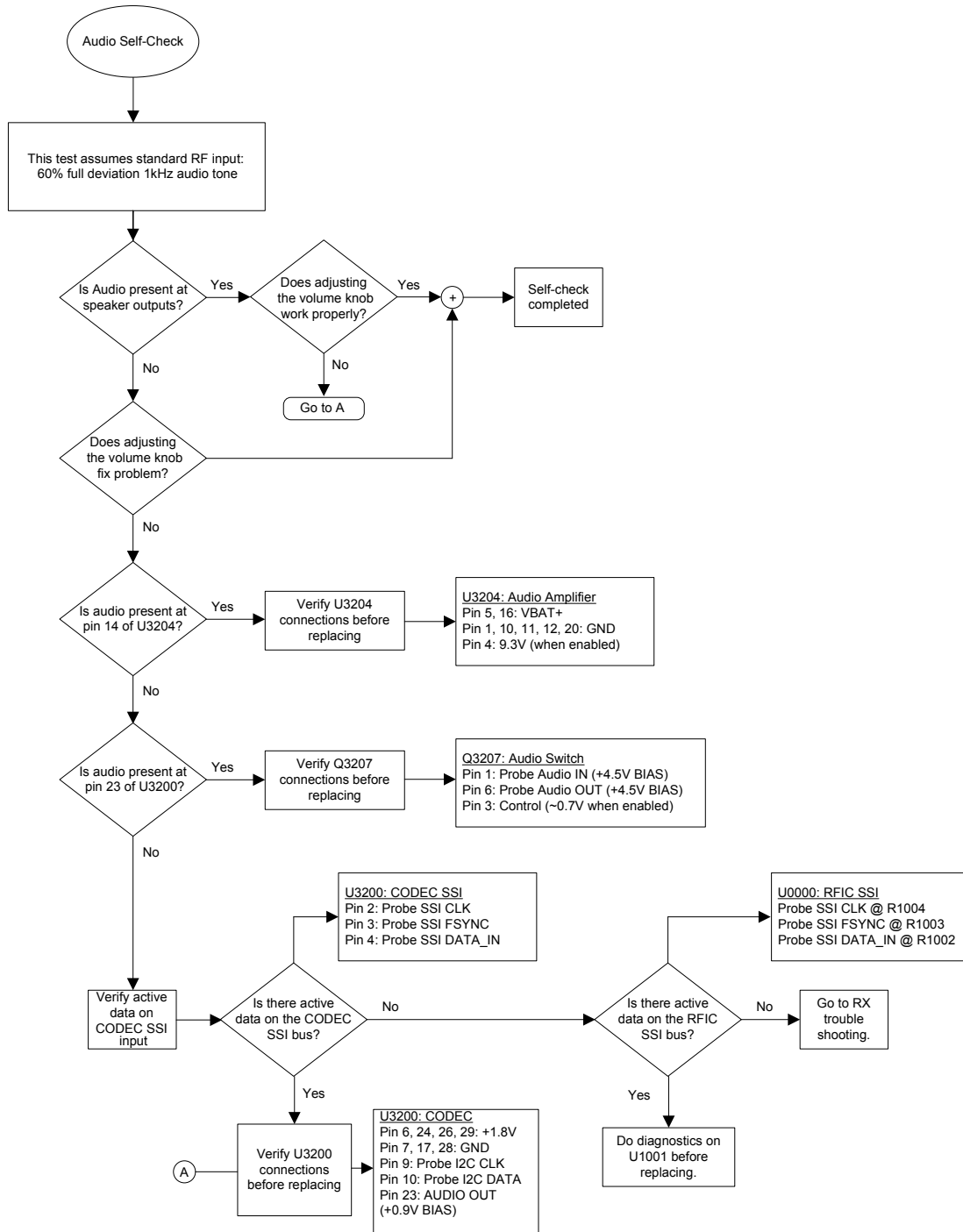

Figure 16: Troubleshooting Chart for Audio



7.3 Troubleshooting Charts for Part and Component

7.3.1 Troubleshooting Flowchart for Receiver

VHF Low and High Power Service Information

Figure 17: Troubleshooting Flow Chart for Receiver for 84012734001-A (Sheet 1 of 3)

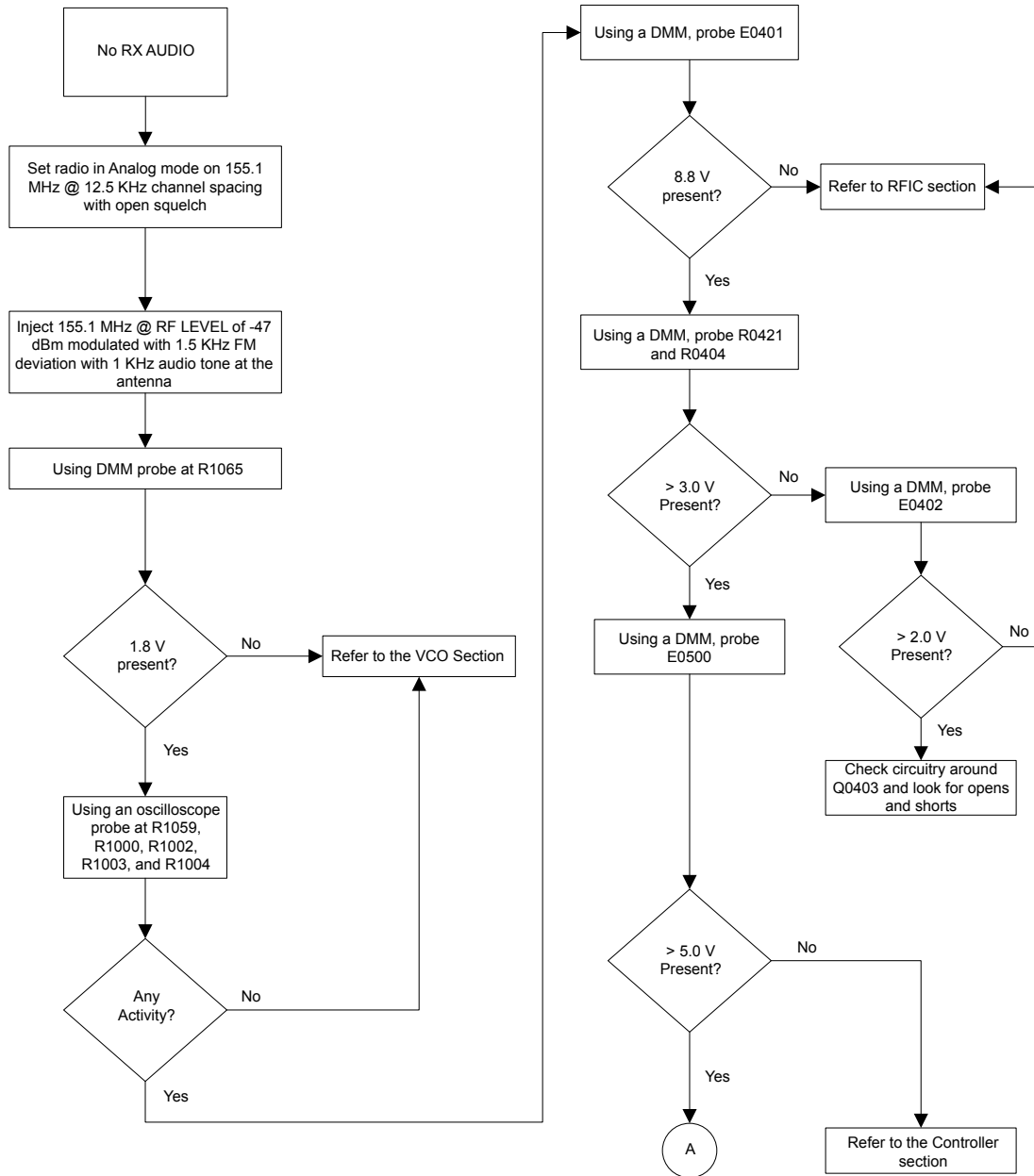

Figure 18: Troubleshooting Flow Chart for Receiver for 84012734001-A (Sheet 2 of 3)

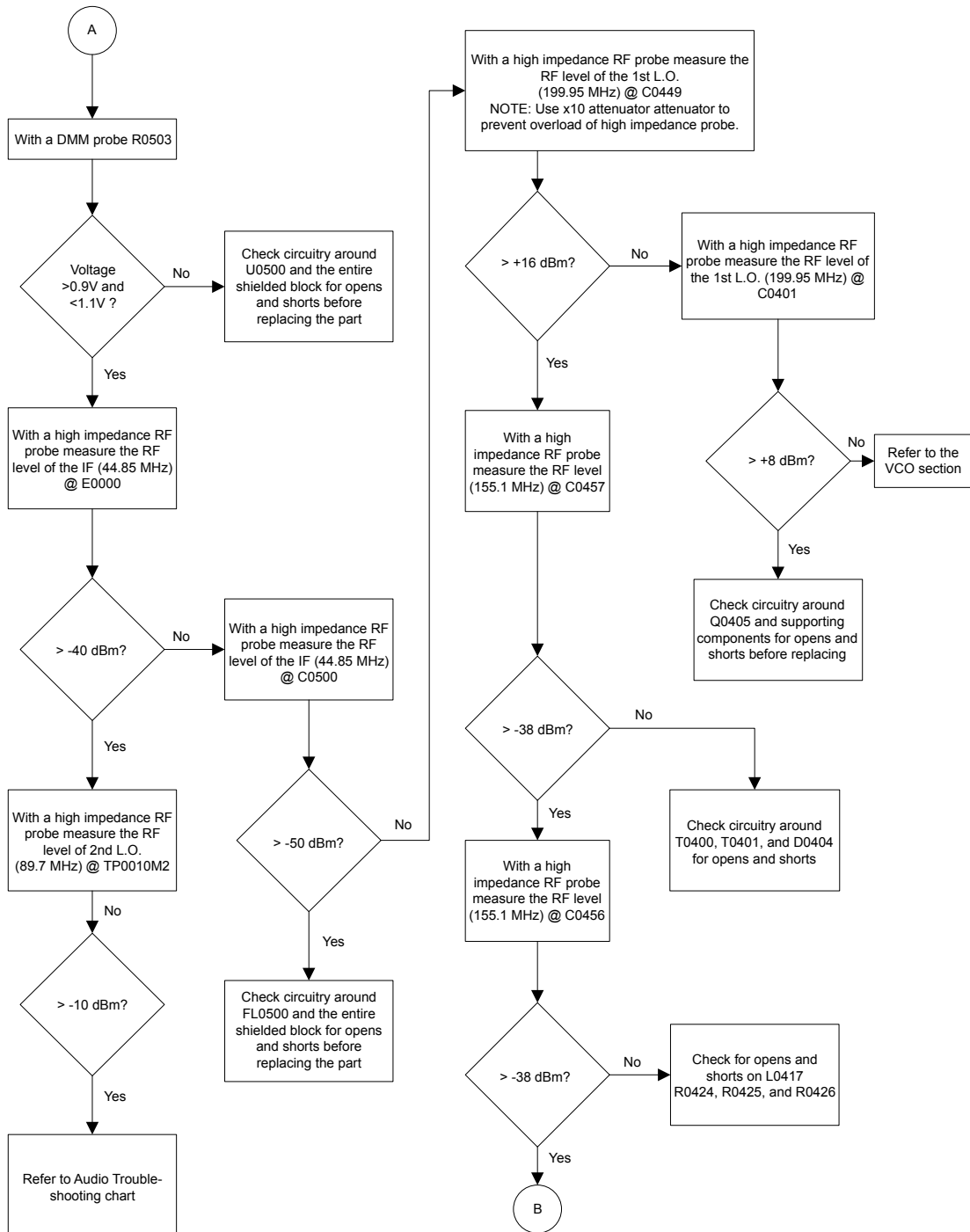

Figure 19: Troubleshooting Flow Chart for Receiver for 84012734001-A (Sheet 3 of 3)

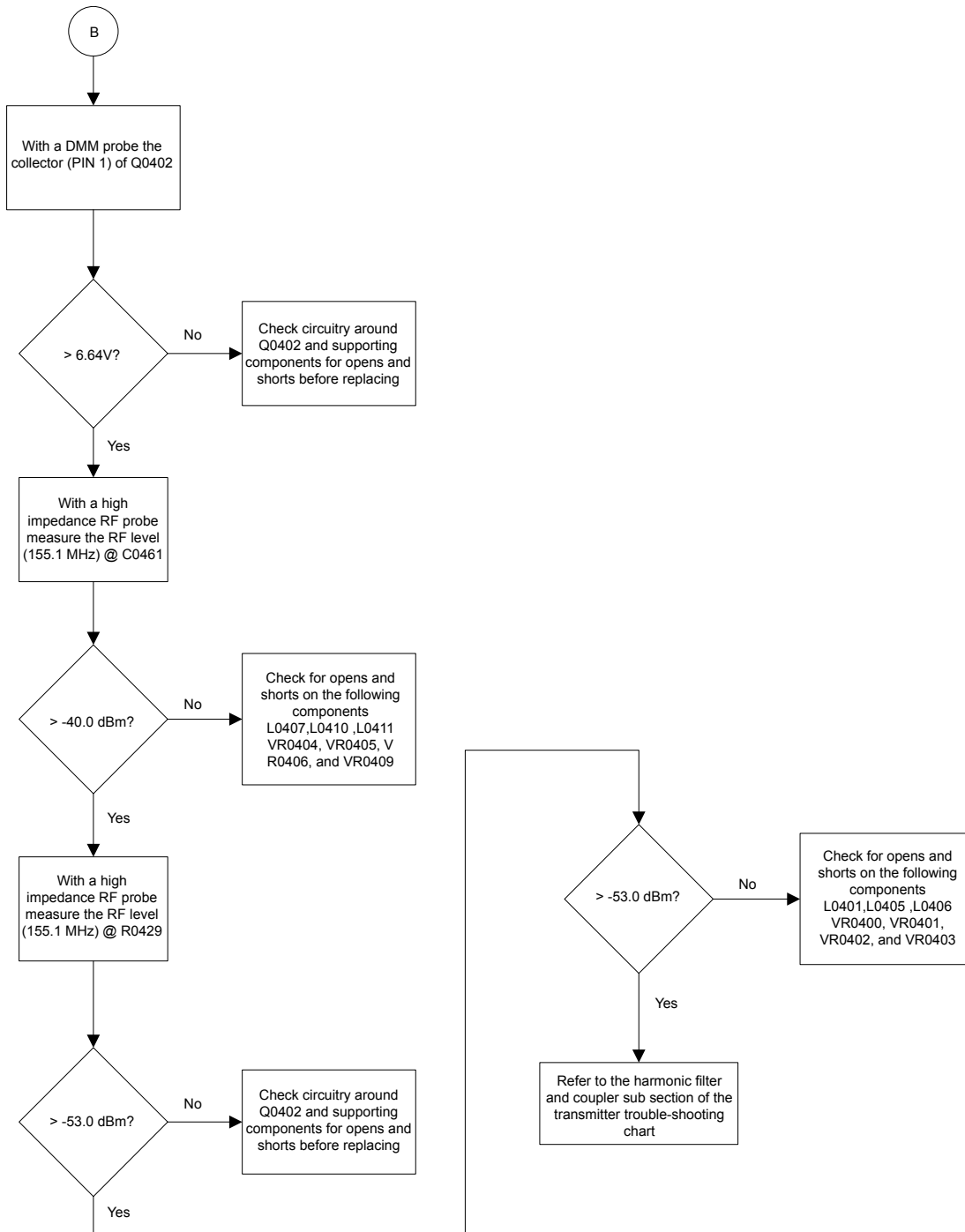

Figure 20: Troubleshooting Flow Chart for Receiver for 84012734002-B (Sheet 1 of 3)

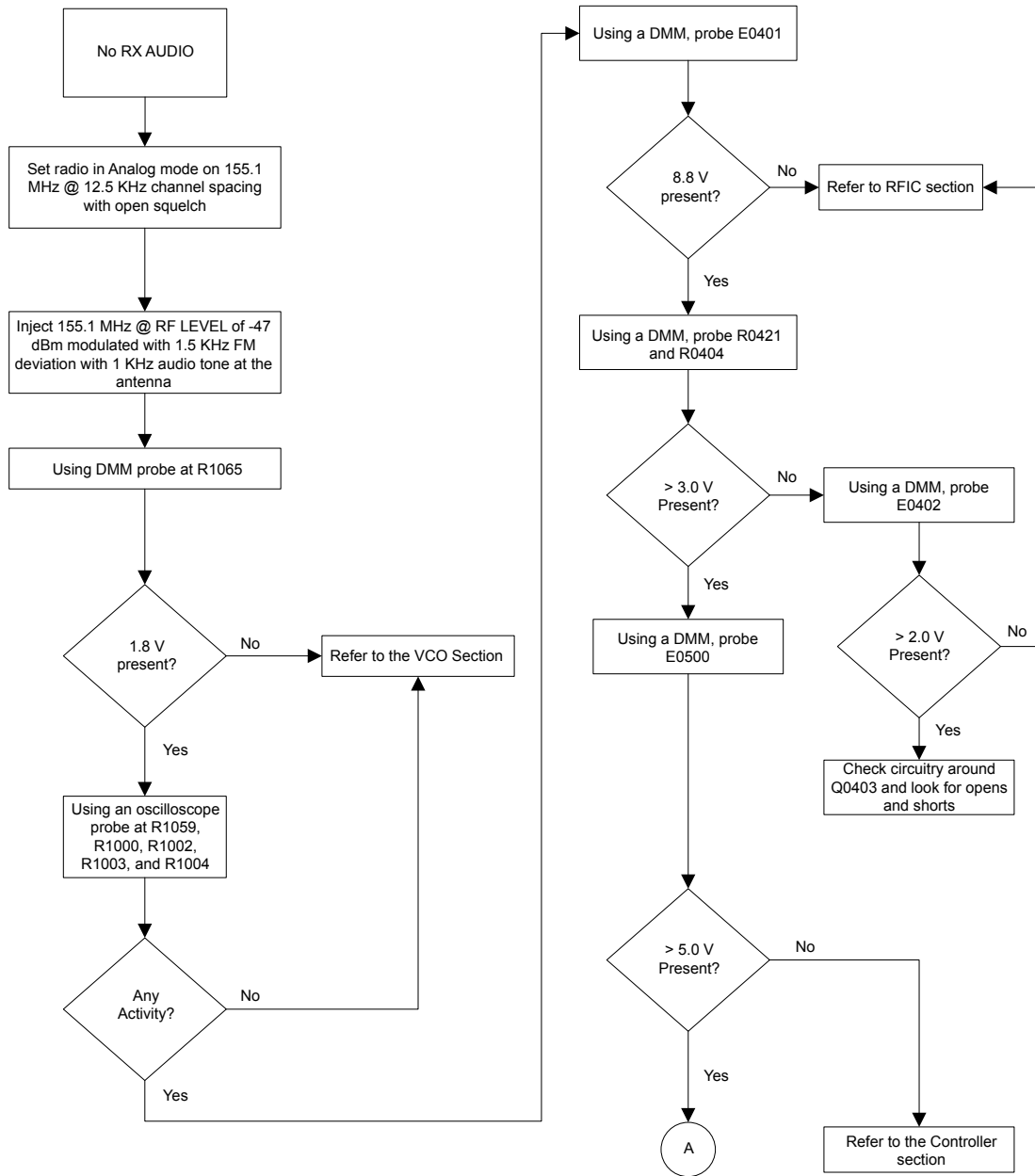

Figure 21: Troubleshooting Flow Chart for Receiver for 84012734002-B (Sheet 2 of 3)

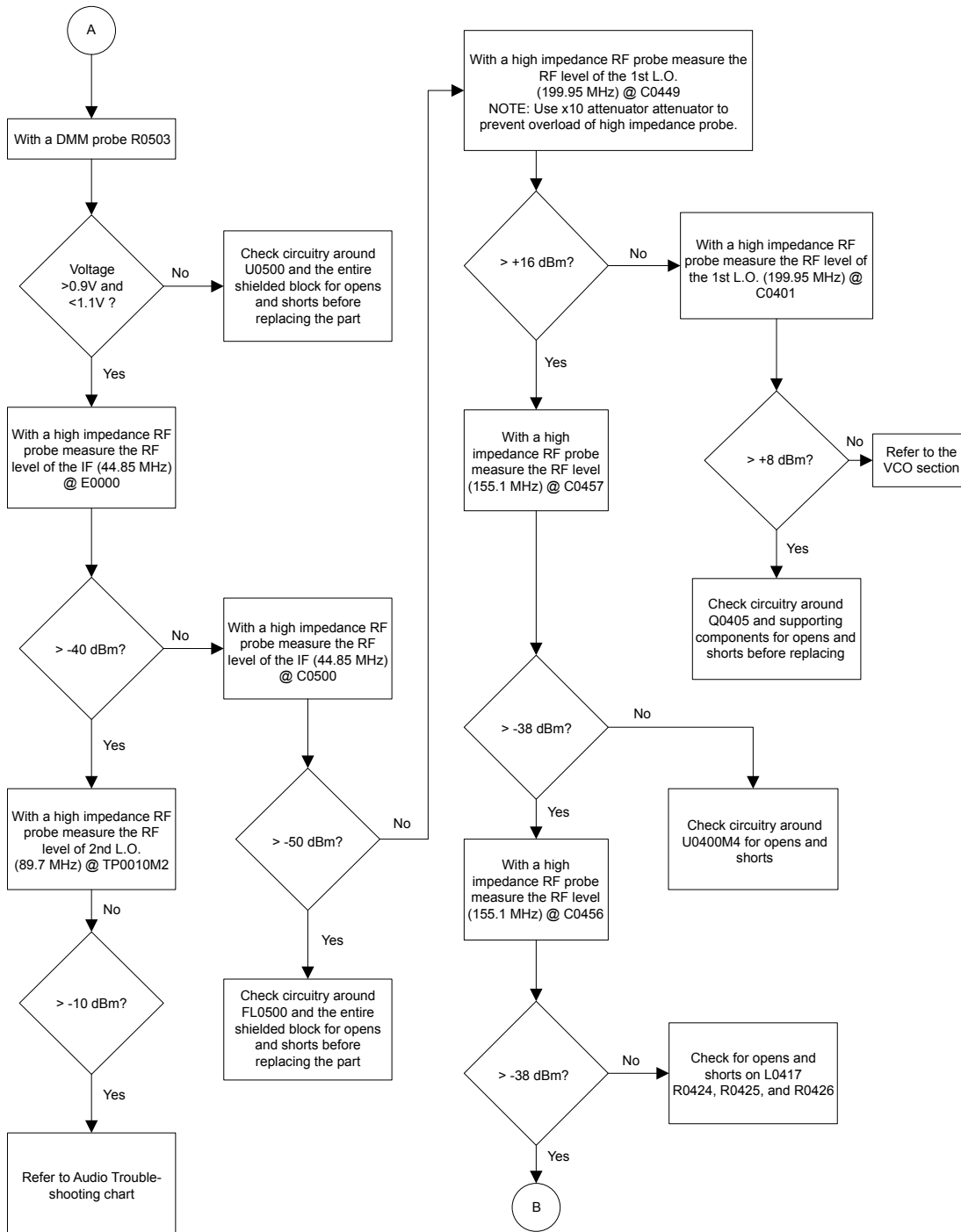
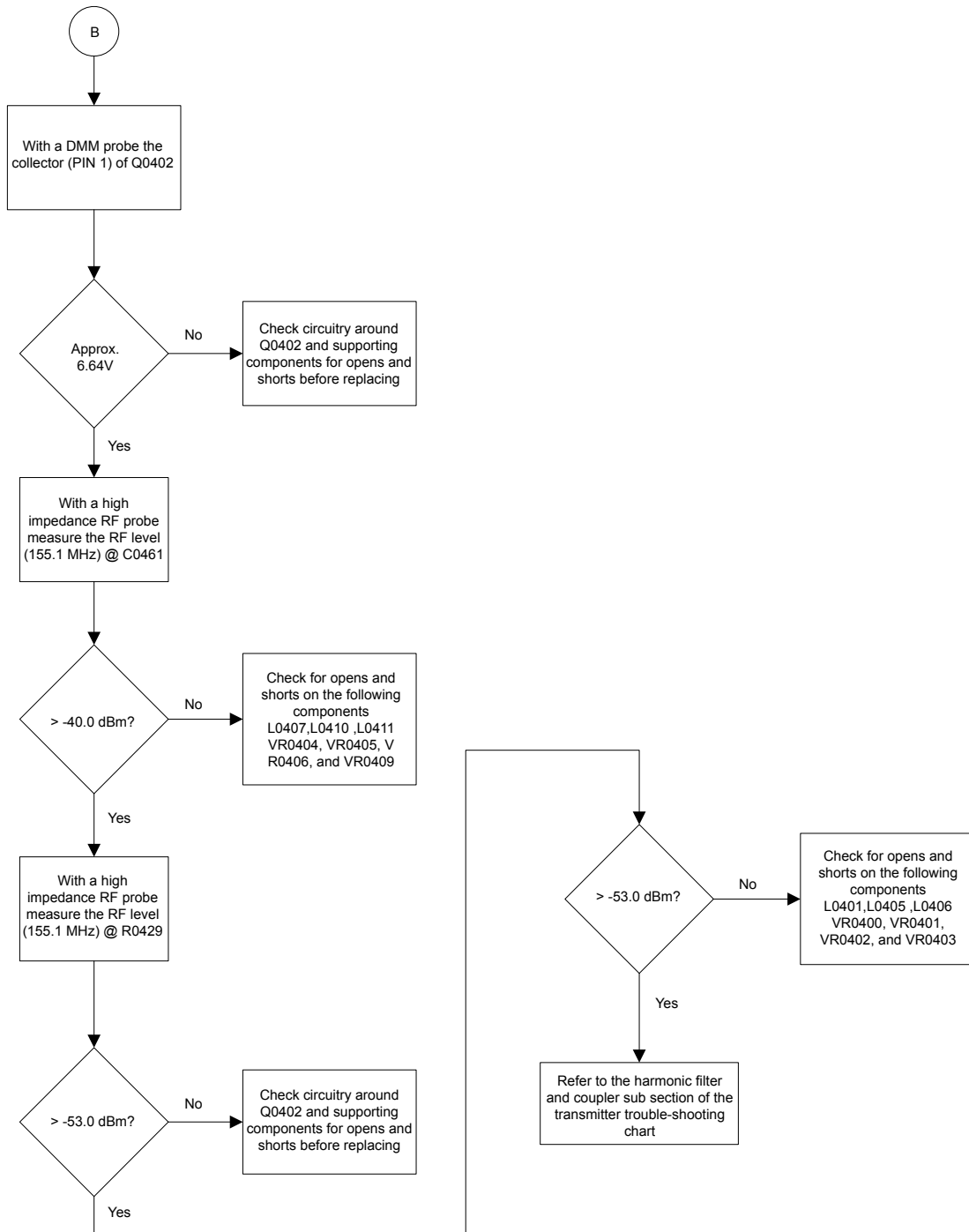

Figure 22: Troubleshooting Flow Chart for Receiver for 84012734002-B (Sheet 3 of 3)



UHF1 Low Power Service Information

Figure 23: Troubleshooting Flow Chart for Receiver for 84012735001-A (Sheet 1 of 3)

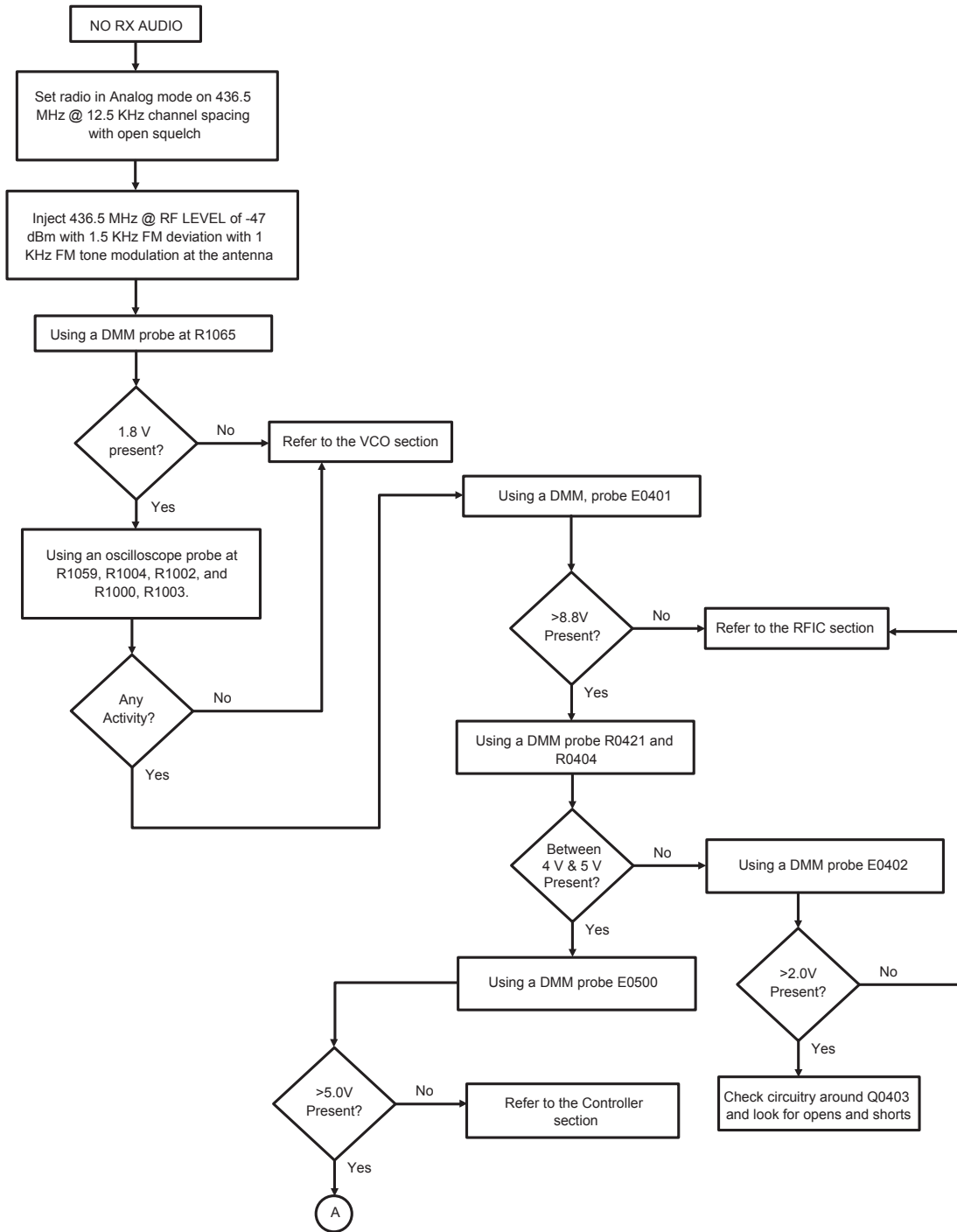

Figure 24: Troubleshooting Flow Chart for Receiver for 84012735001-A (Sheet 2 of 3)

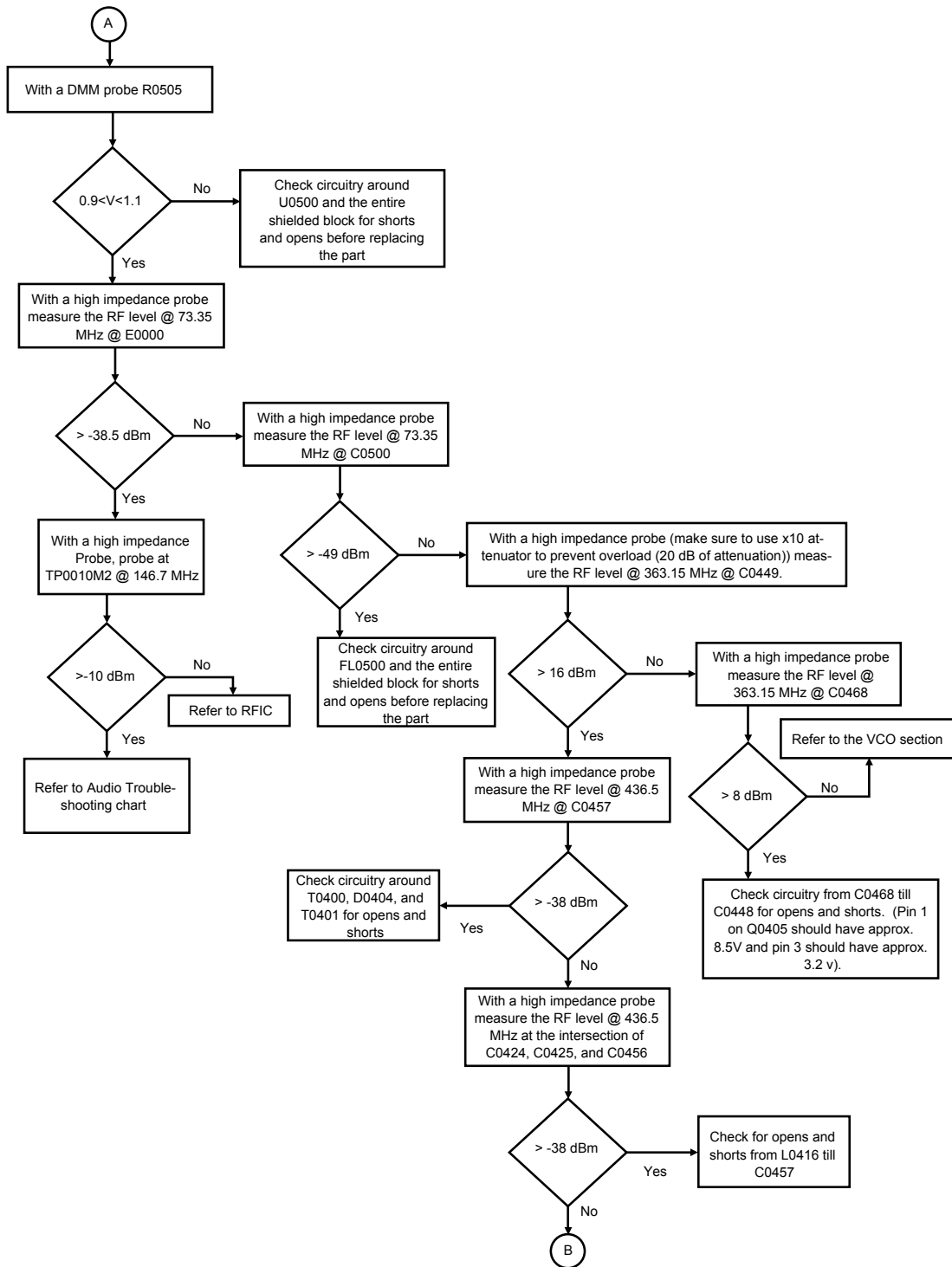

Figure 25: Troubleshooting Flow Chart for Receiver for 84012735001-A (Sheet 3 of 3)

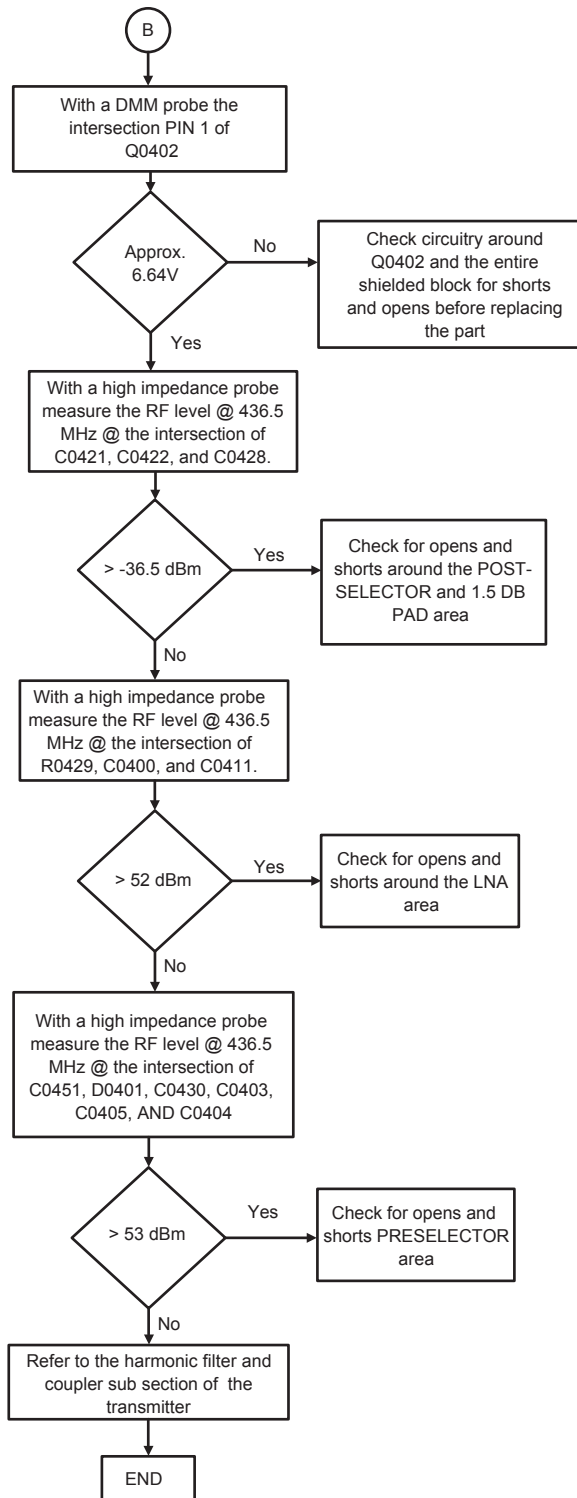

Figure 26: Troubleshooting Flow Chart for Receiver for 84012735003-C (Sheet 1 of 3)

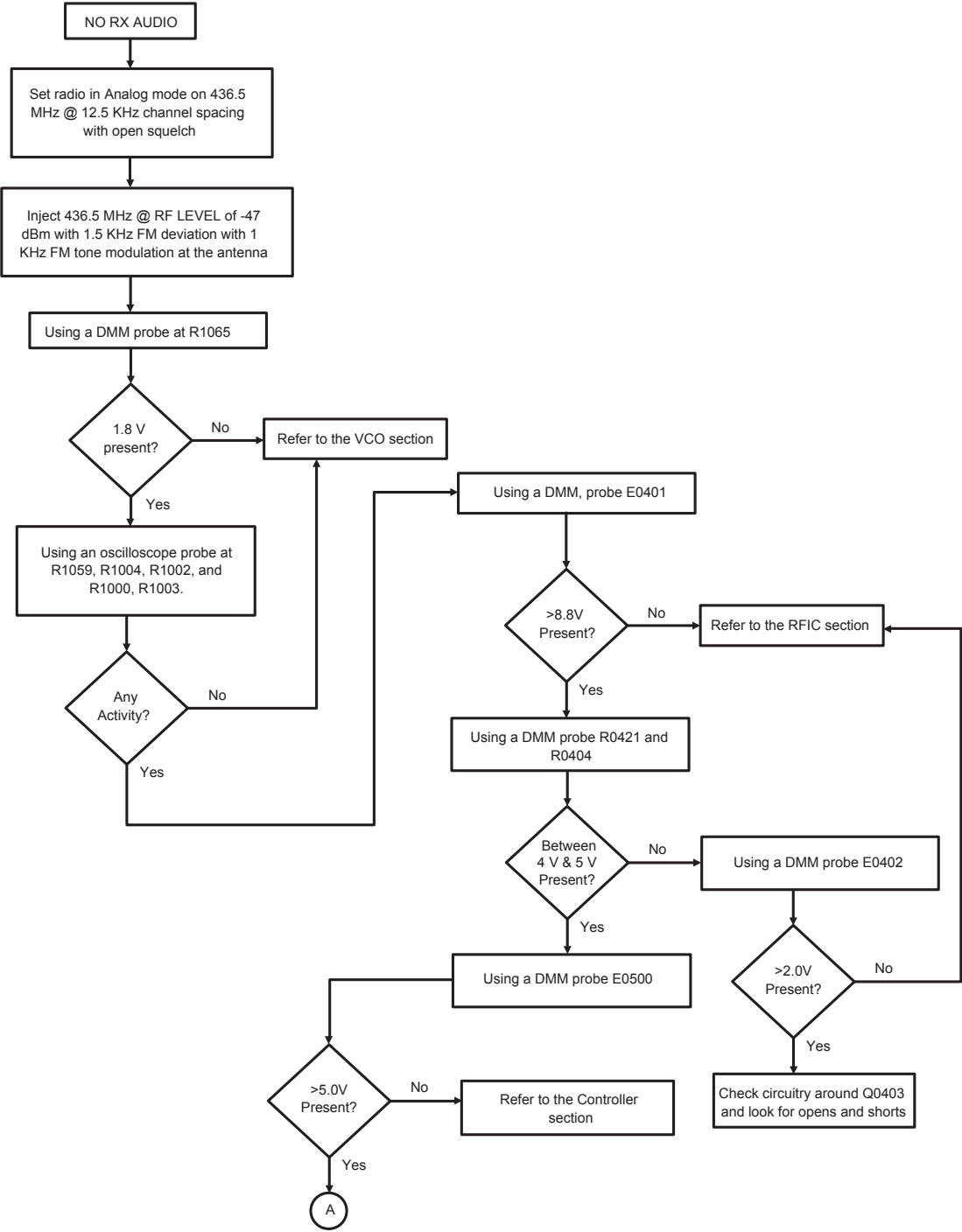

Figure 27: Troubleshooting Flow Chart for Receiver for 84012735003-C (Sheet 2 of 3)

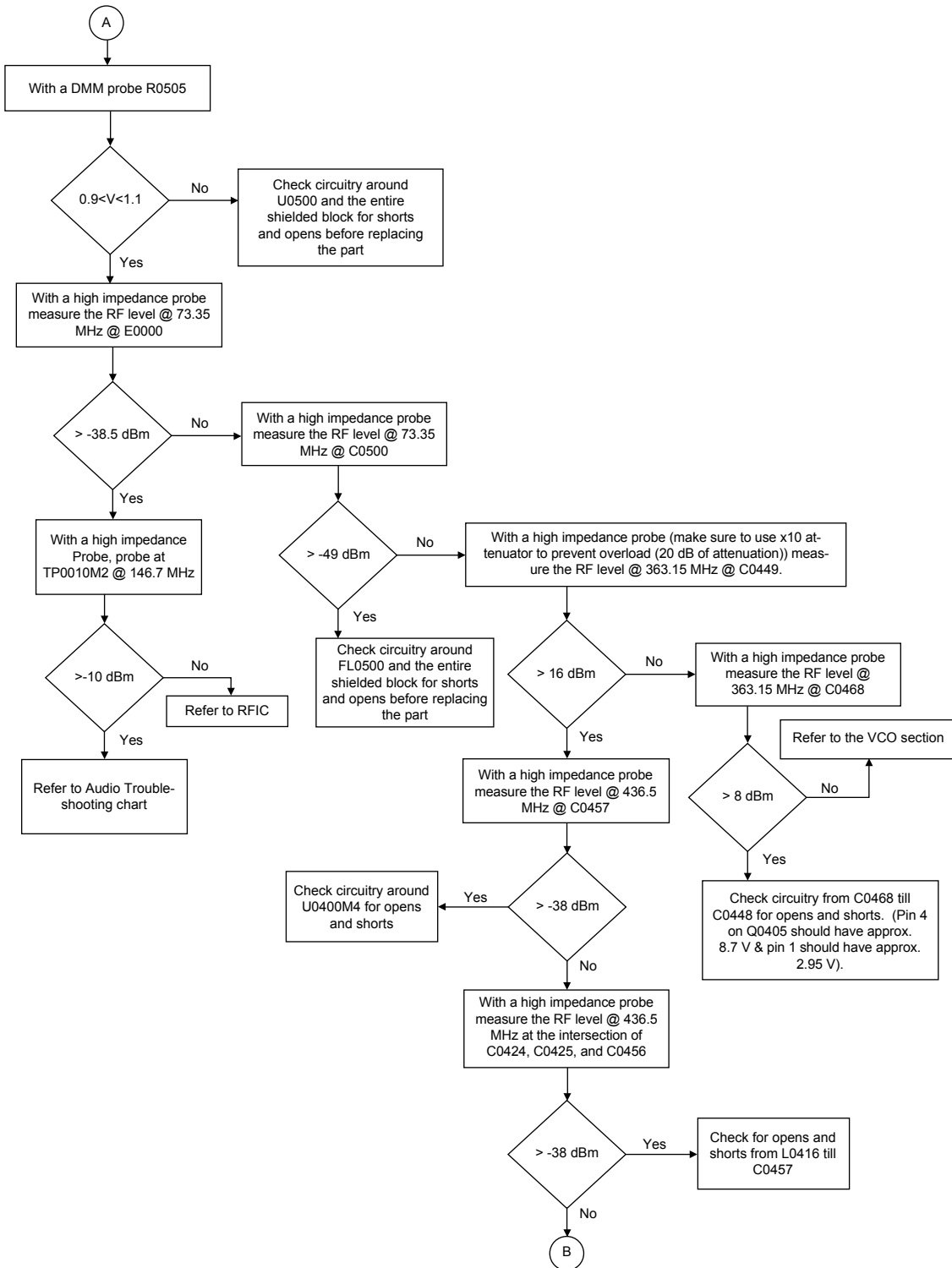
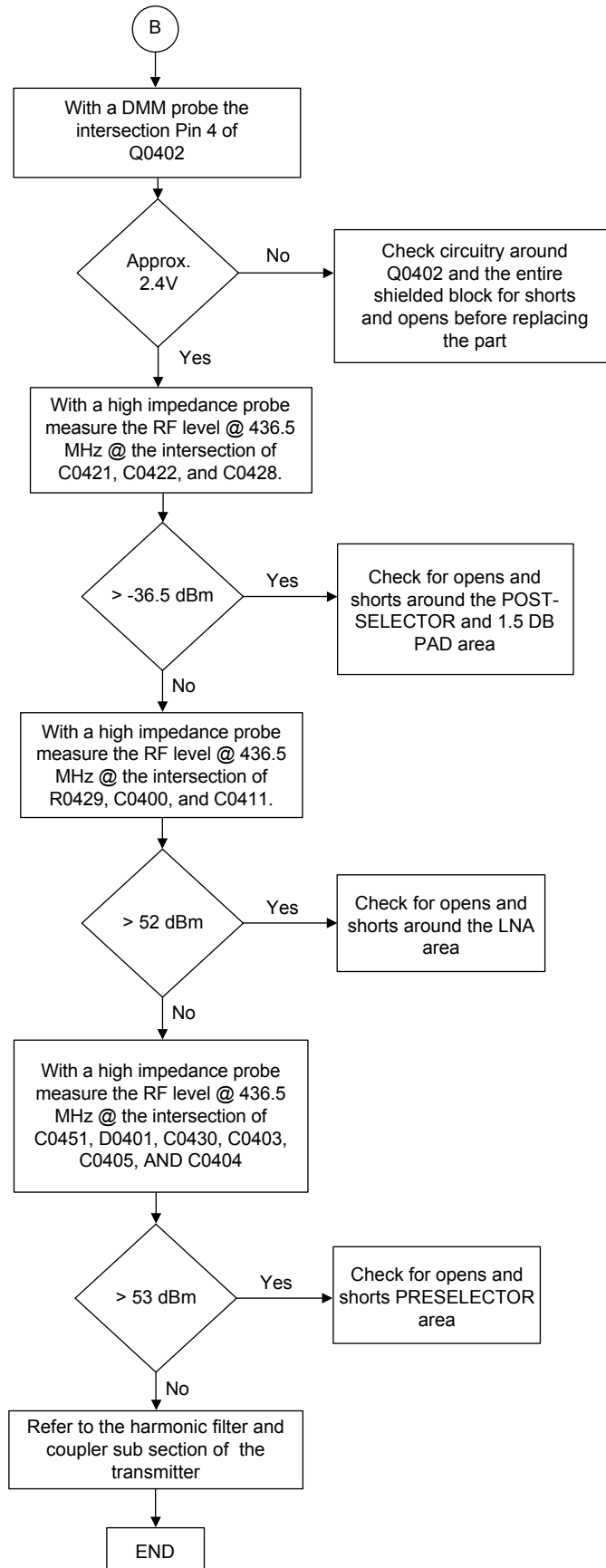

Figure 28: Troubleshooting Flow Chart for Receiver for 84012735003-C (Sheet 3 of 3)



UHF1 High Power Service Information

Figure 29: Troubleshooting Flow Chart for Receiver for 84012737001-A (Sheet 1 of 3)

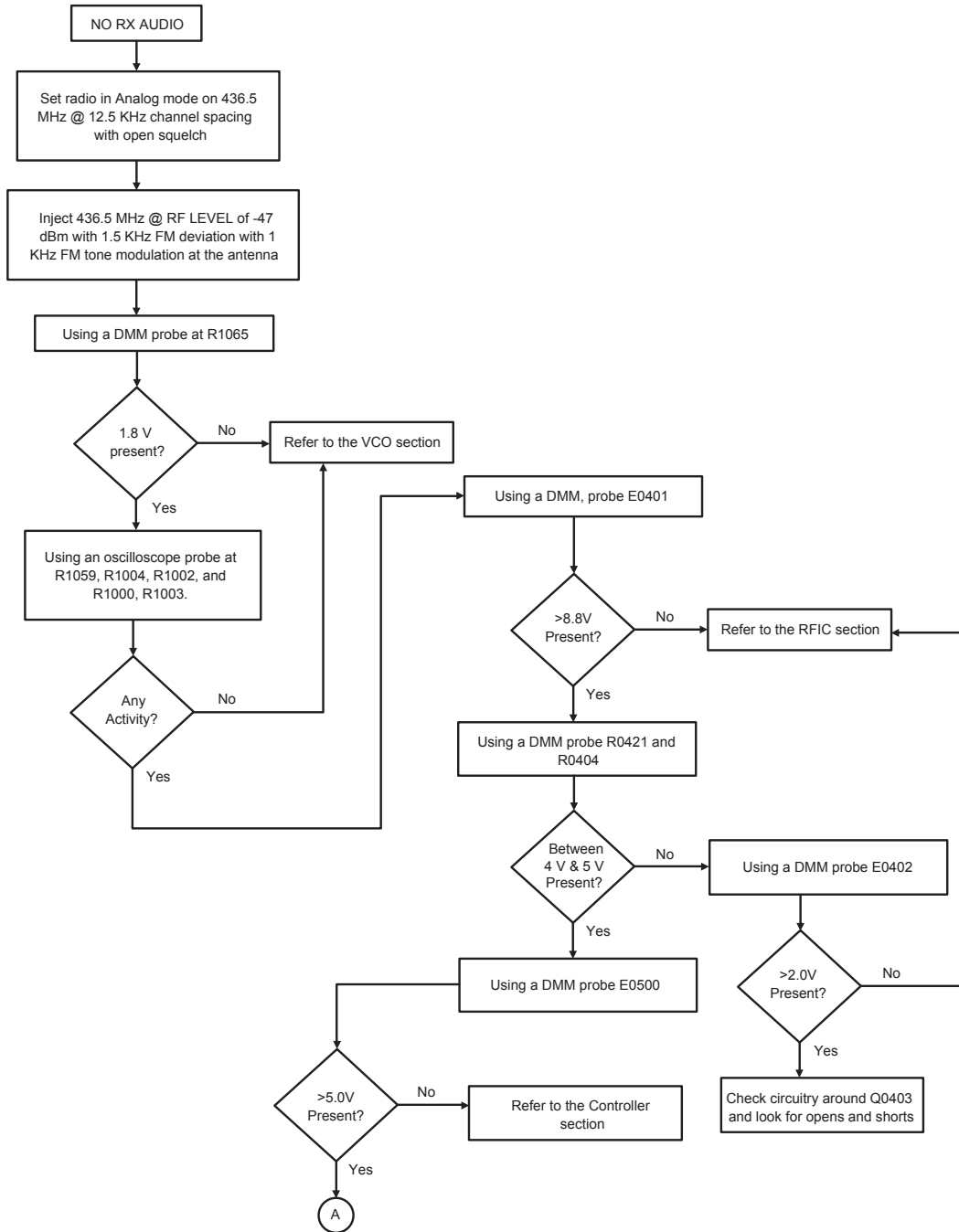

Figure 30: Troubleshooting Flow Chart for Receiver for 84012737001-A (Sheet 2 of 3)

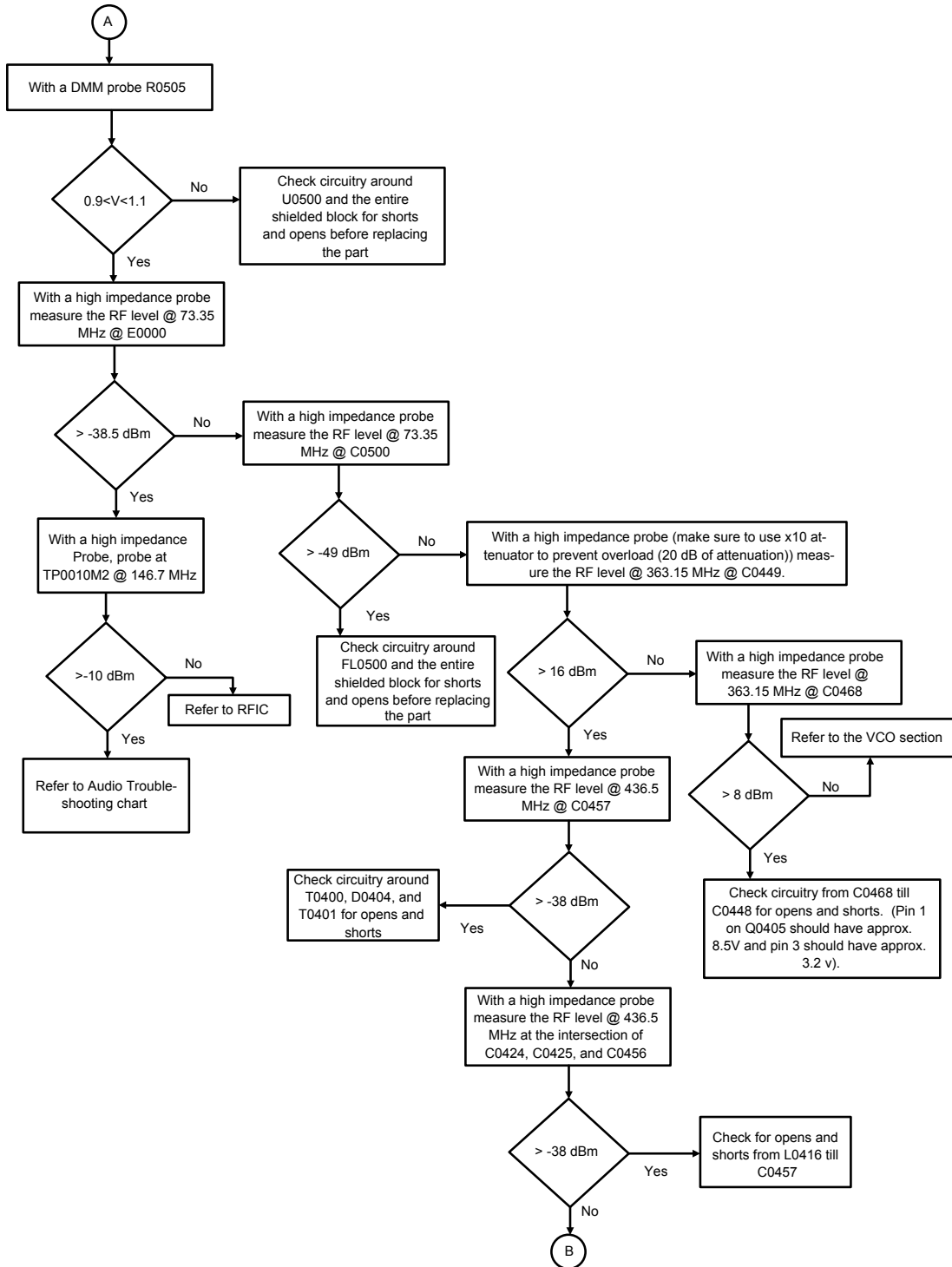

Figure 31: Troubleshooting Flow Chart for Receiver for 84012737001-A (Sheet 3 of 3)

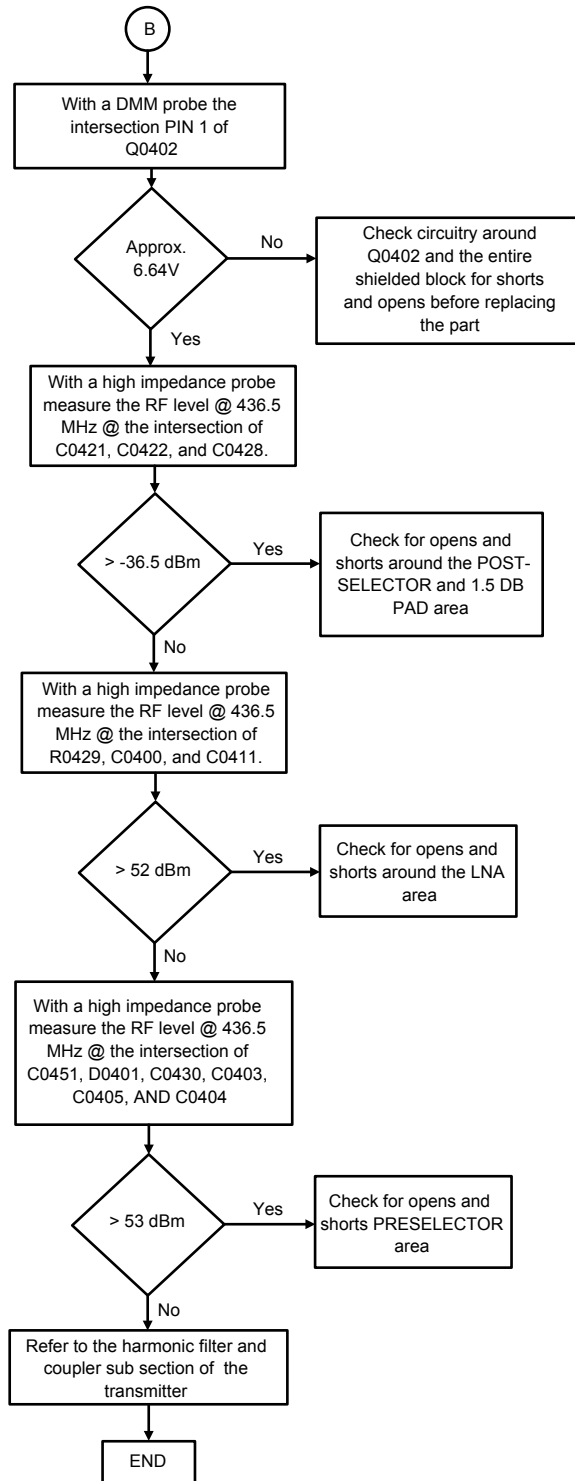

Figure 32: Troubleshooting Flow Chart for Receiver for 84012737003-C (Sheet 1 of 3)

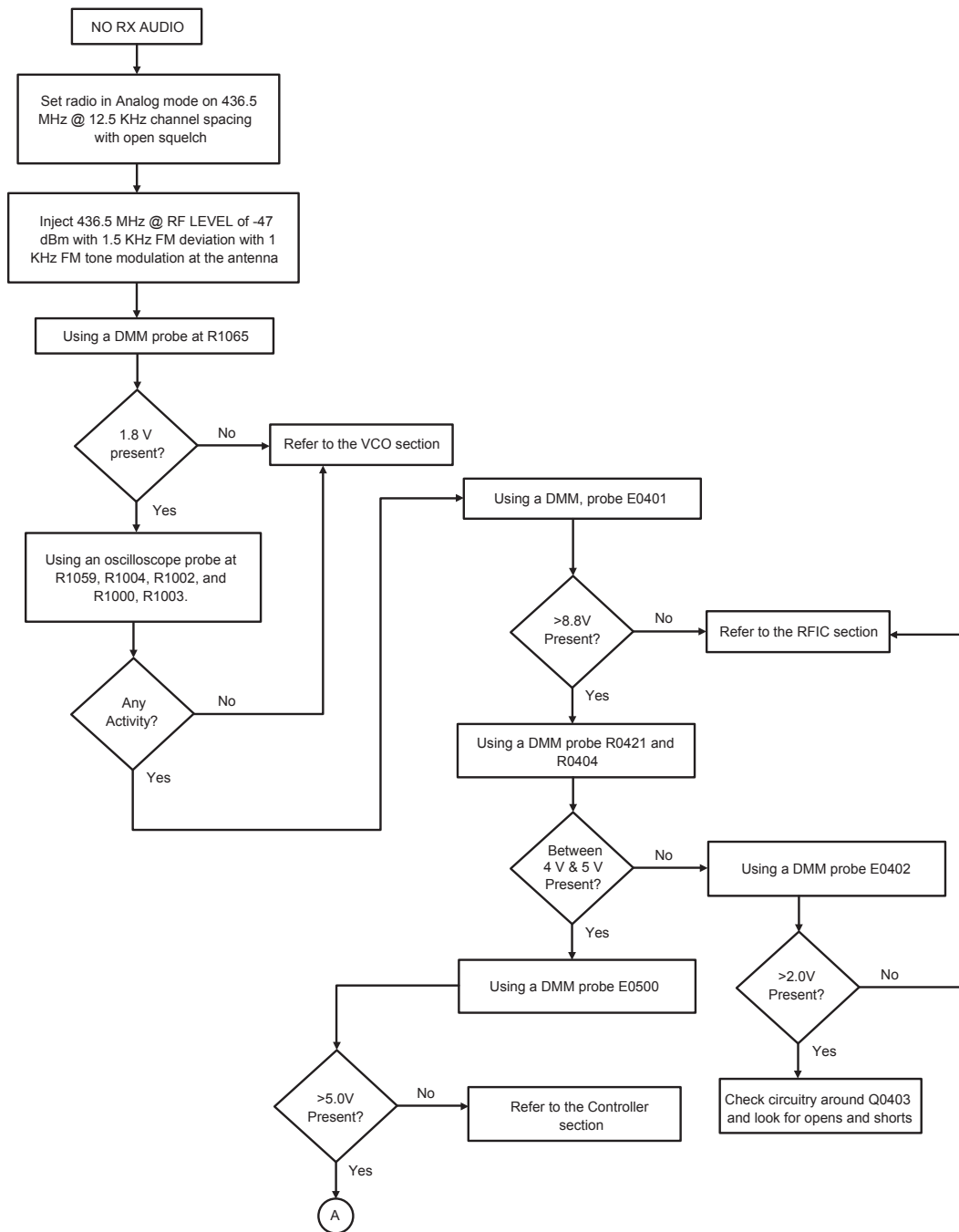

Figure 33: Troubleshooting Flow Chart for Receiver for 84012737003-C (Sheet 2 of 3)

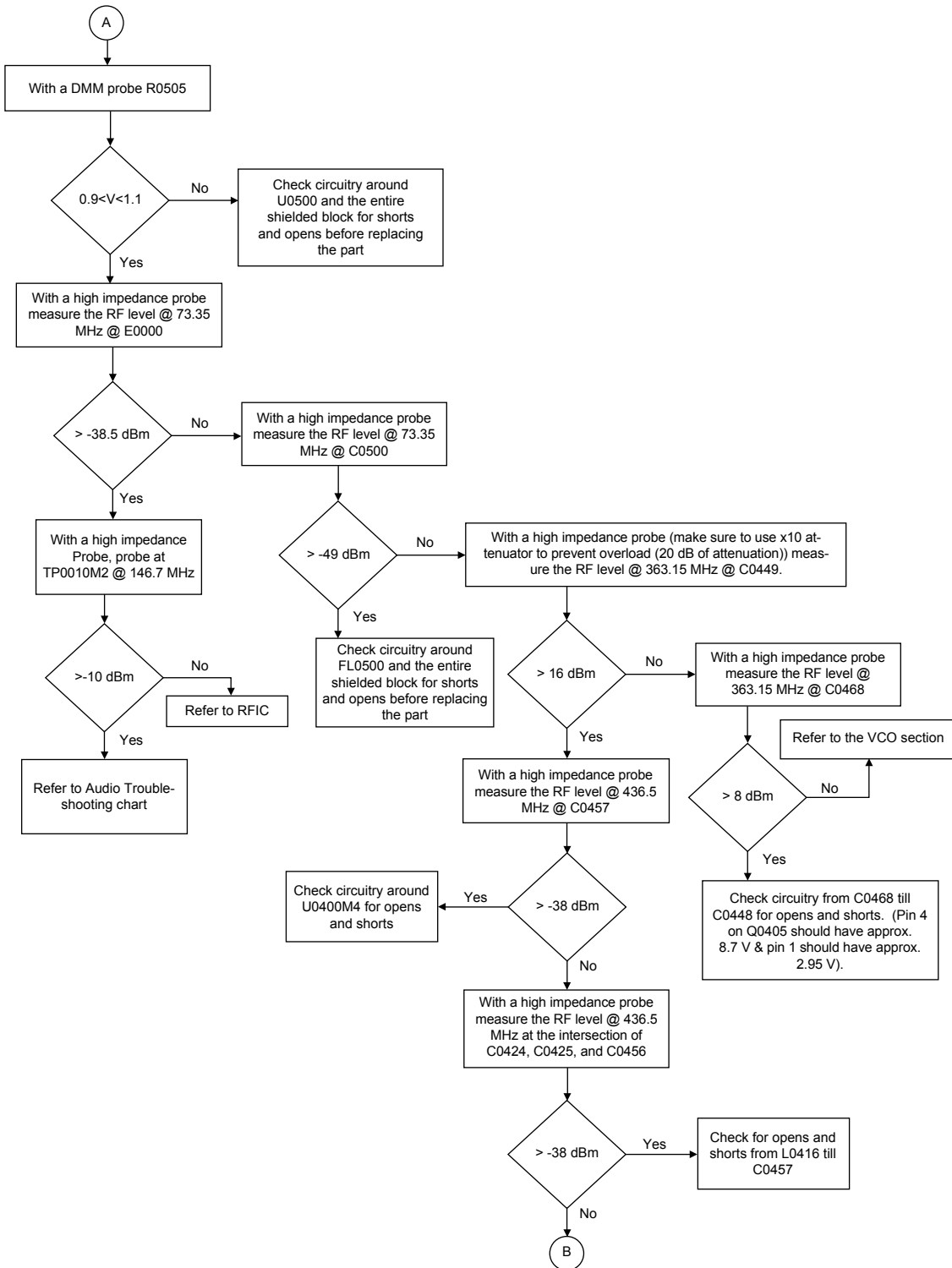
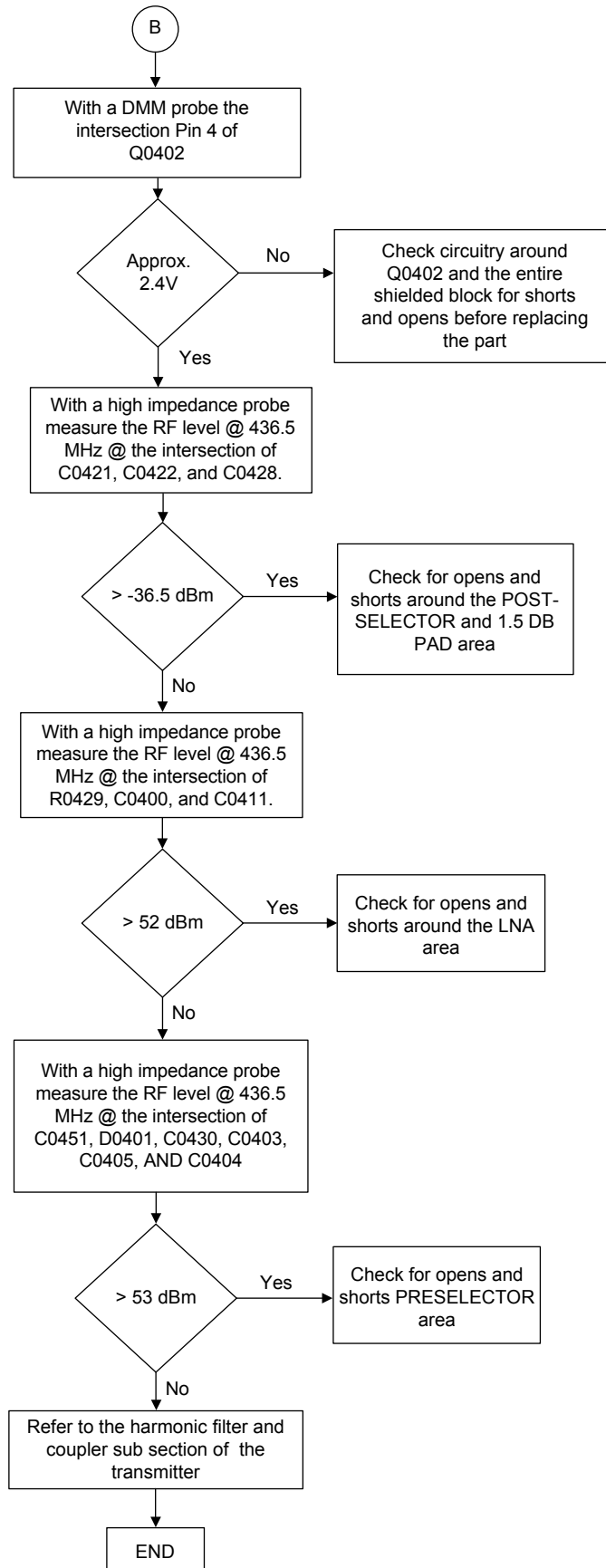

Figure 34: Troubleshooting Flow Chart for Receiver for 84012737003-C (Sheet 3 of 3)



UHF2 Service Information

Figure 35: Troubleshooting Flow Chart for Receiver for 84012728001-A (Sheet 1 of 3)

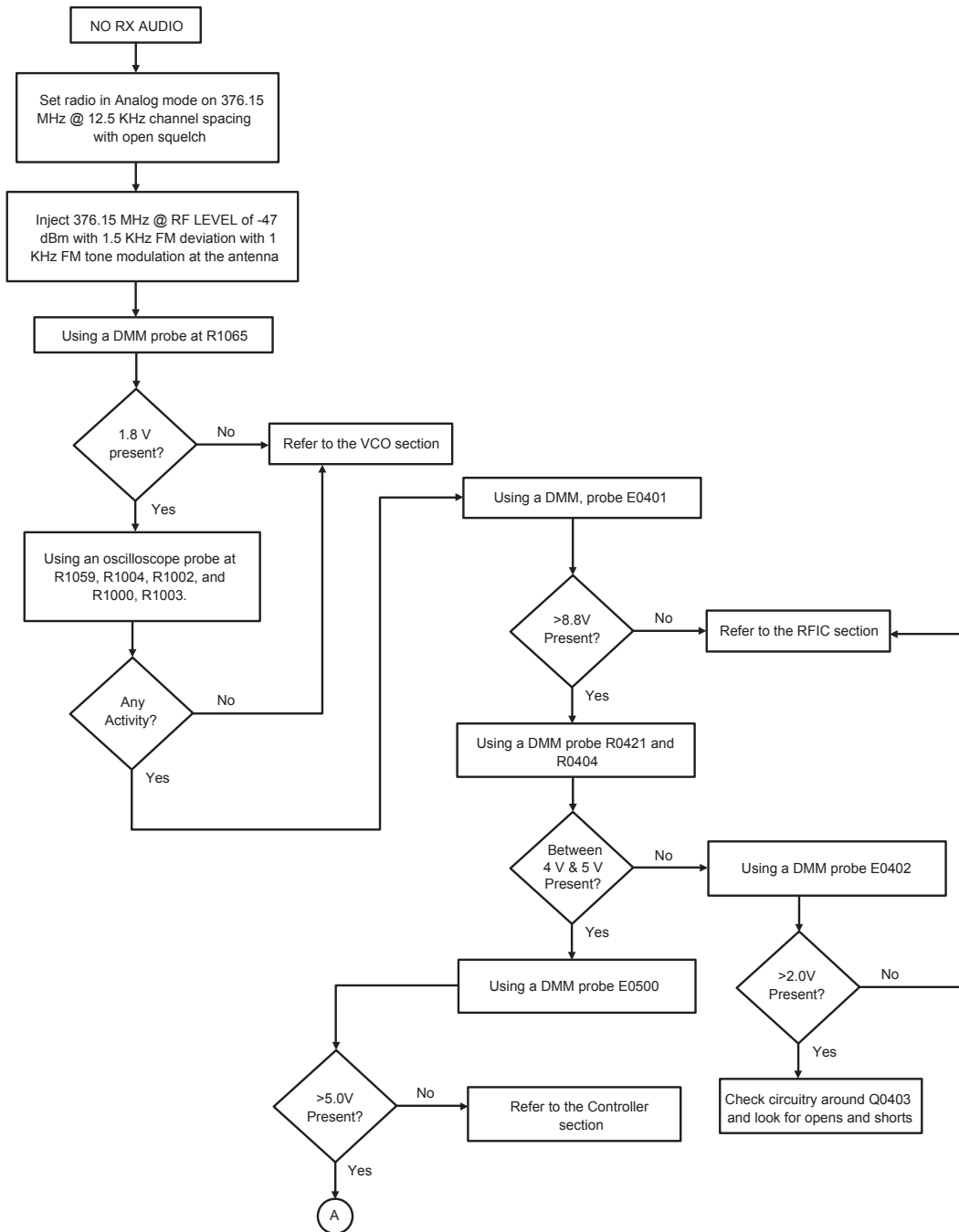

Figure 36: Troubleshooting Flow Chart for Receiver for 84012728001-A (Sheet 2 of 3)

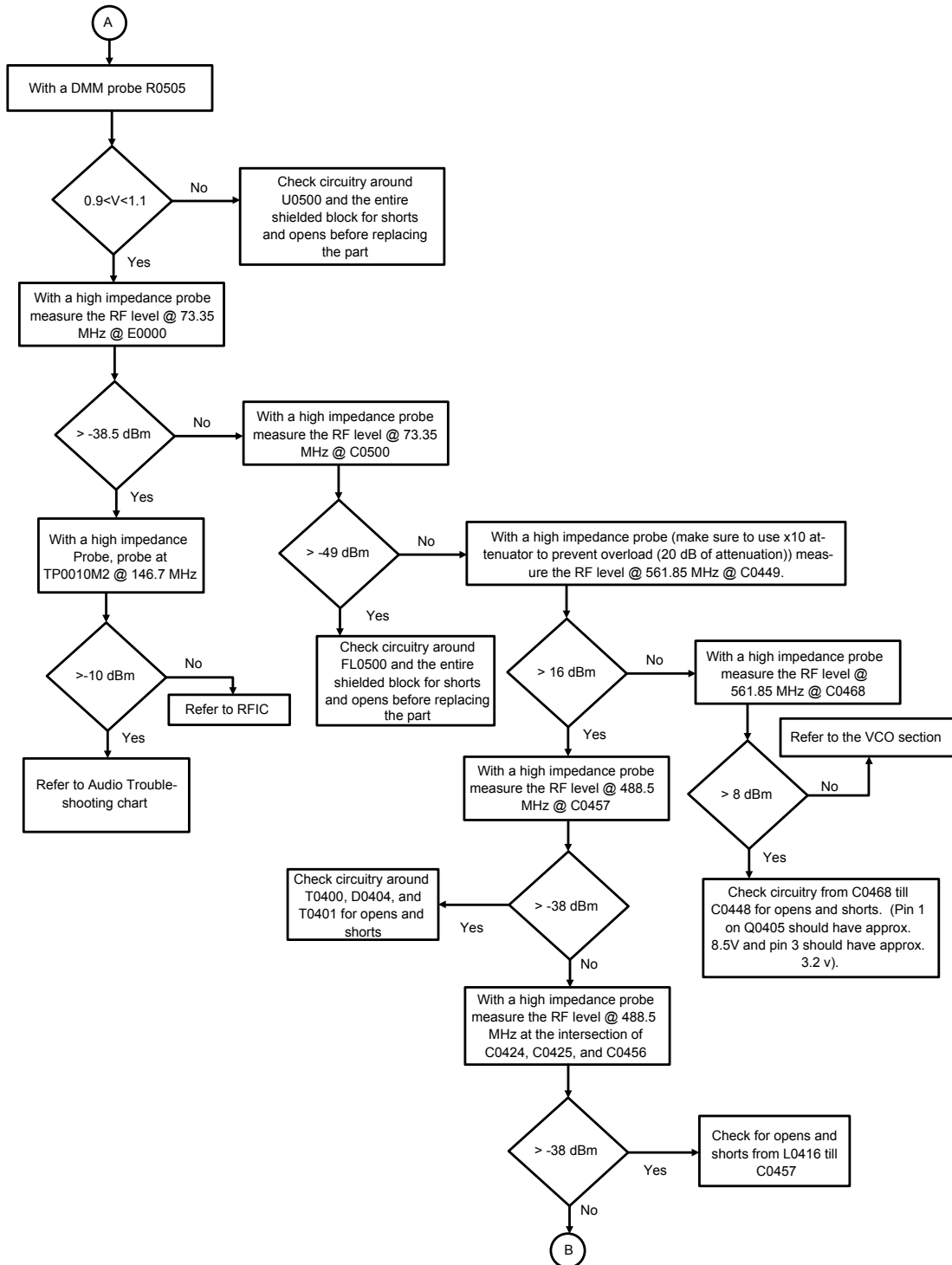

Figure 37: Troubleshooting Flow Chart for Receiver for 84012728001-A (Sheet 3 of 3)

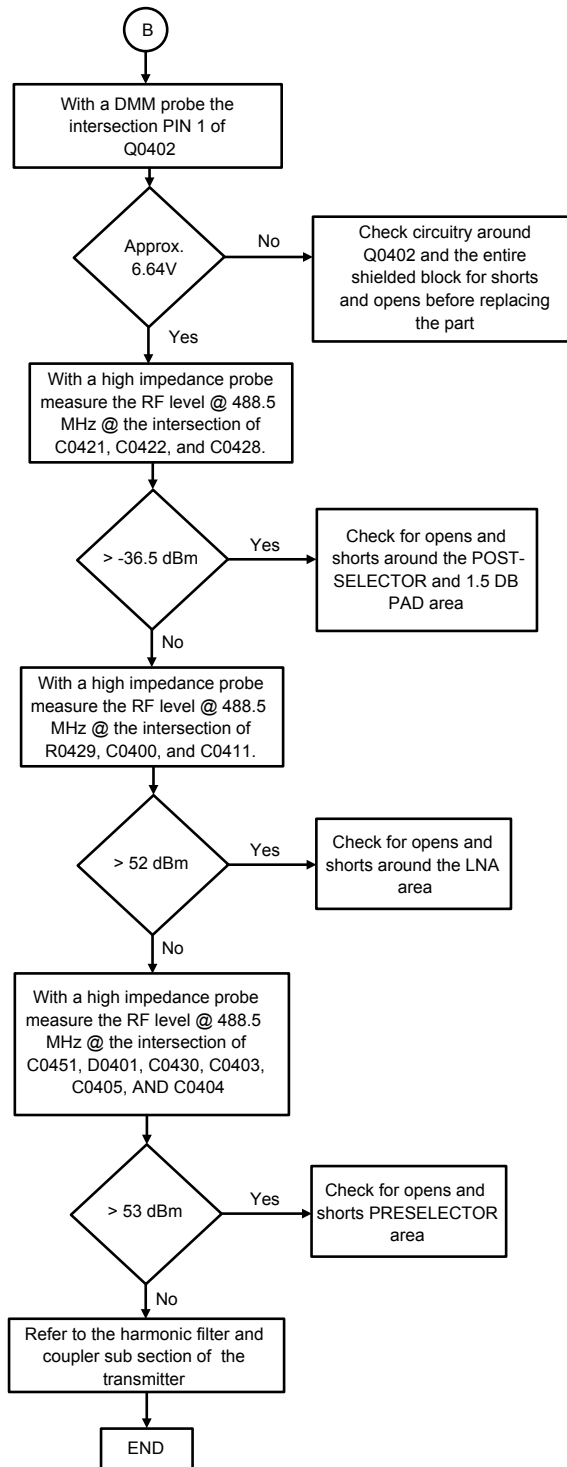

Figure 38: Troubleshooting Flow Chart for Receiver for 84012728003-C (Sheet 1 of 3)

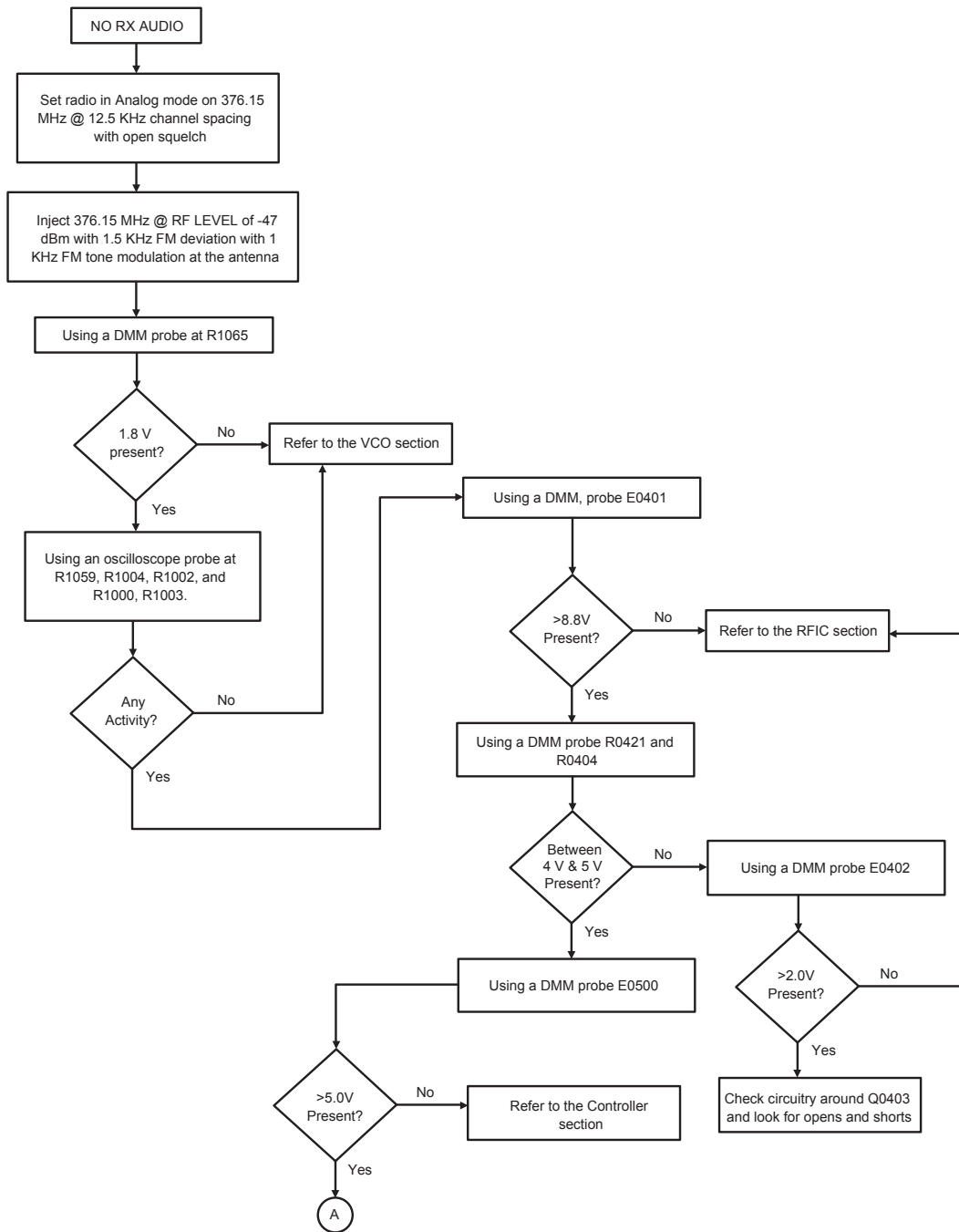

Figure 39: Troubleshooting Flow Chart for Receiver for 84012728003-C (Sheet 2 of 3)

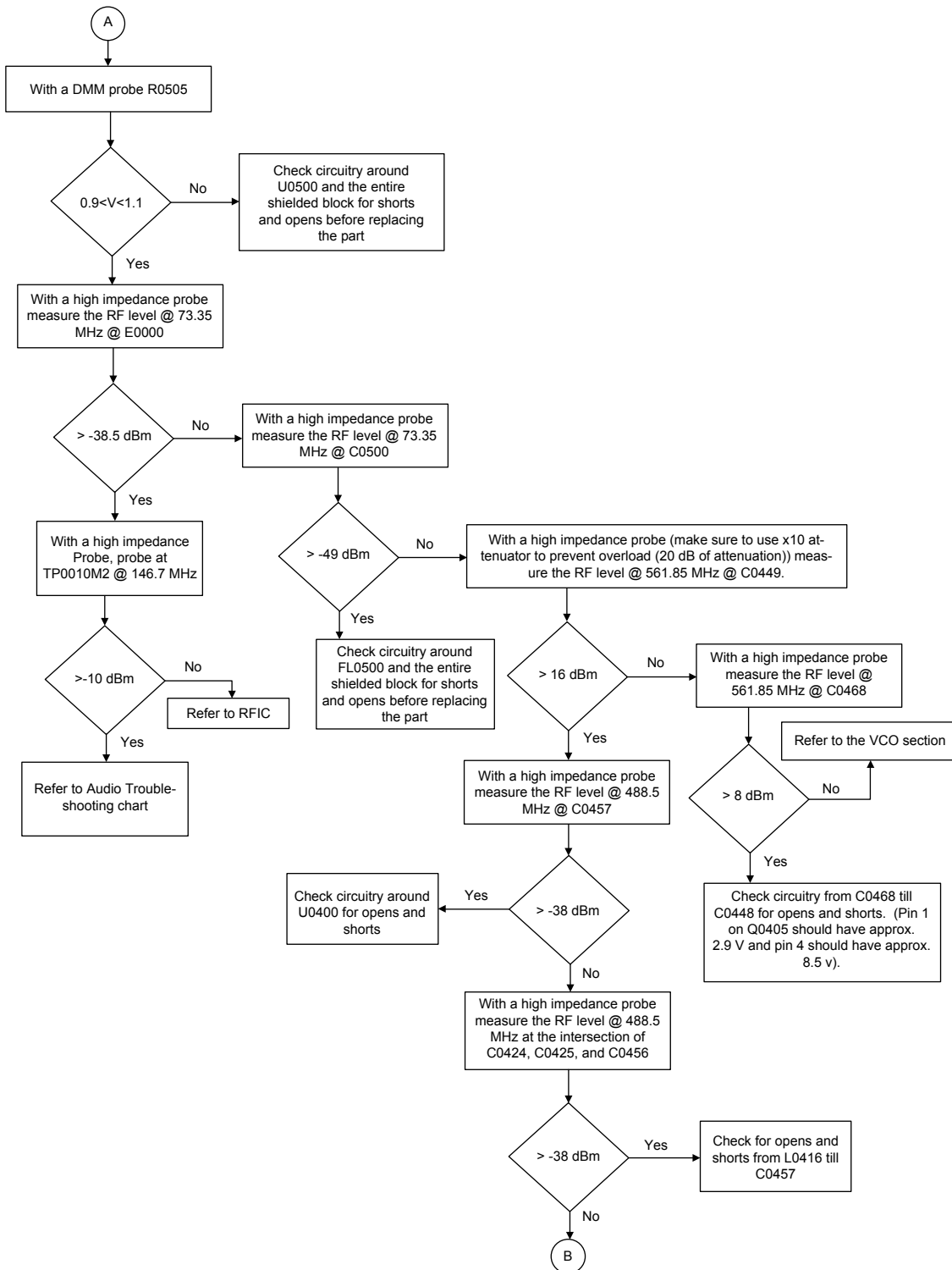
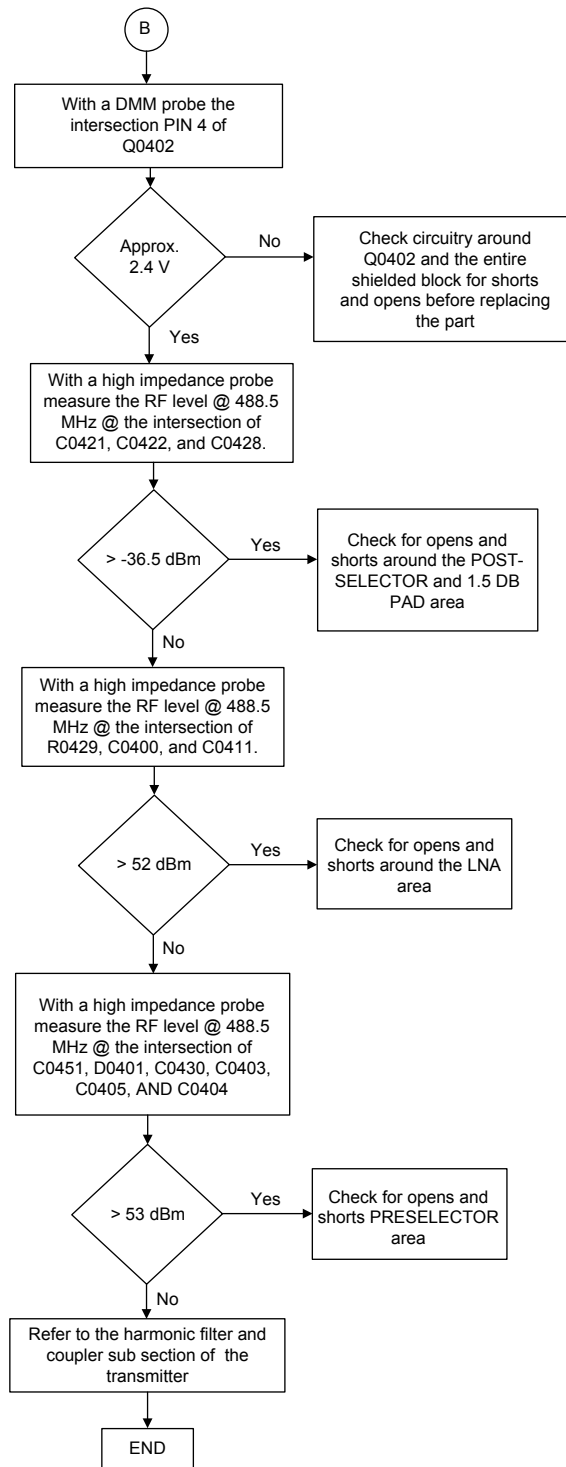

Figure 40: Troubleshooting Flow Chart for Receiver for 84012728003-C (Sheet 3 of 3)



800/900 Band Service Information

Figure 41: Troubleshooting Flow Chart for Receiver (Sheet 1 of 3)

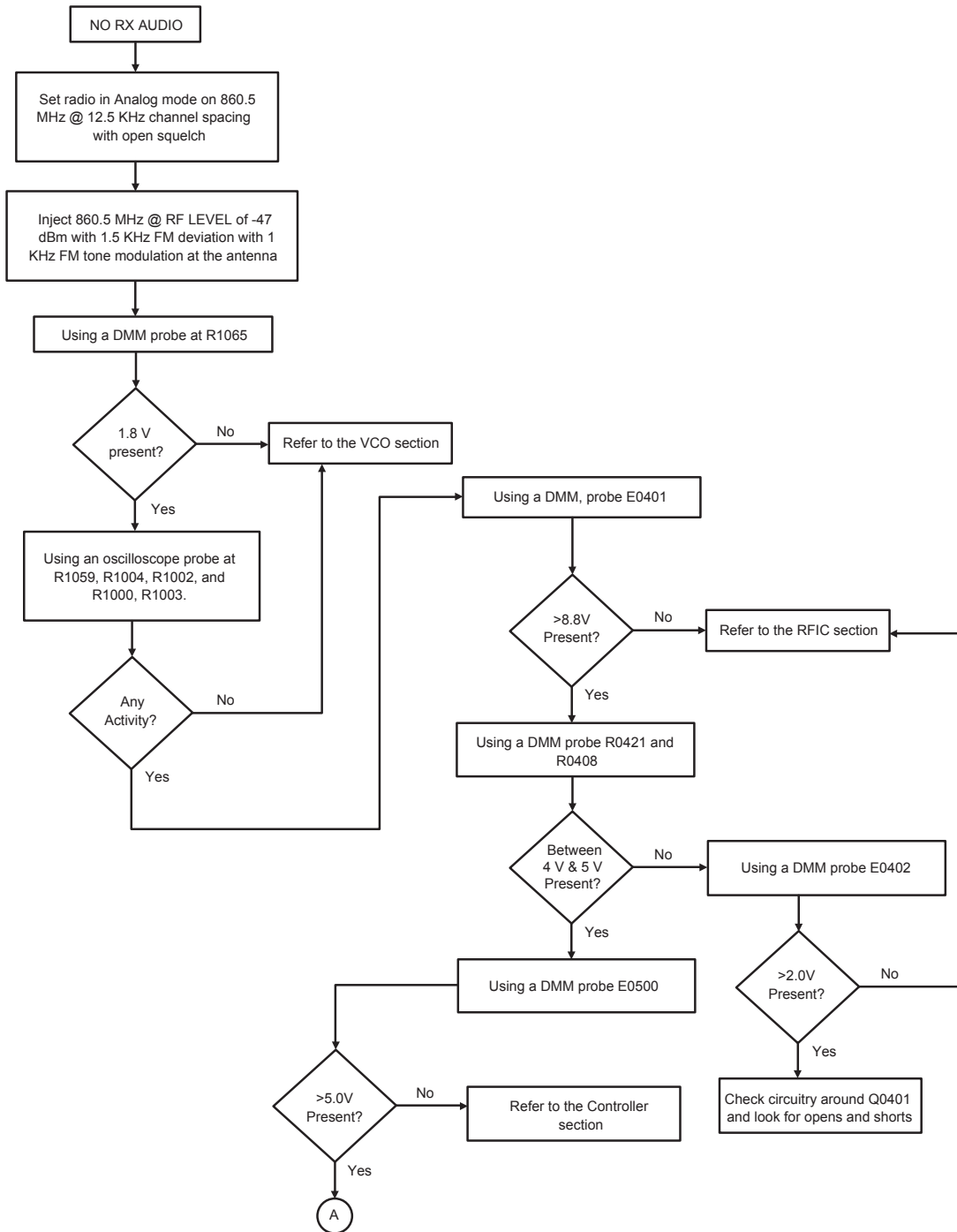

Figure 42: Troubleshooting Flow Chart for Receiver (Sheet 2 of 3)

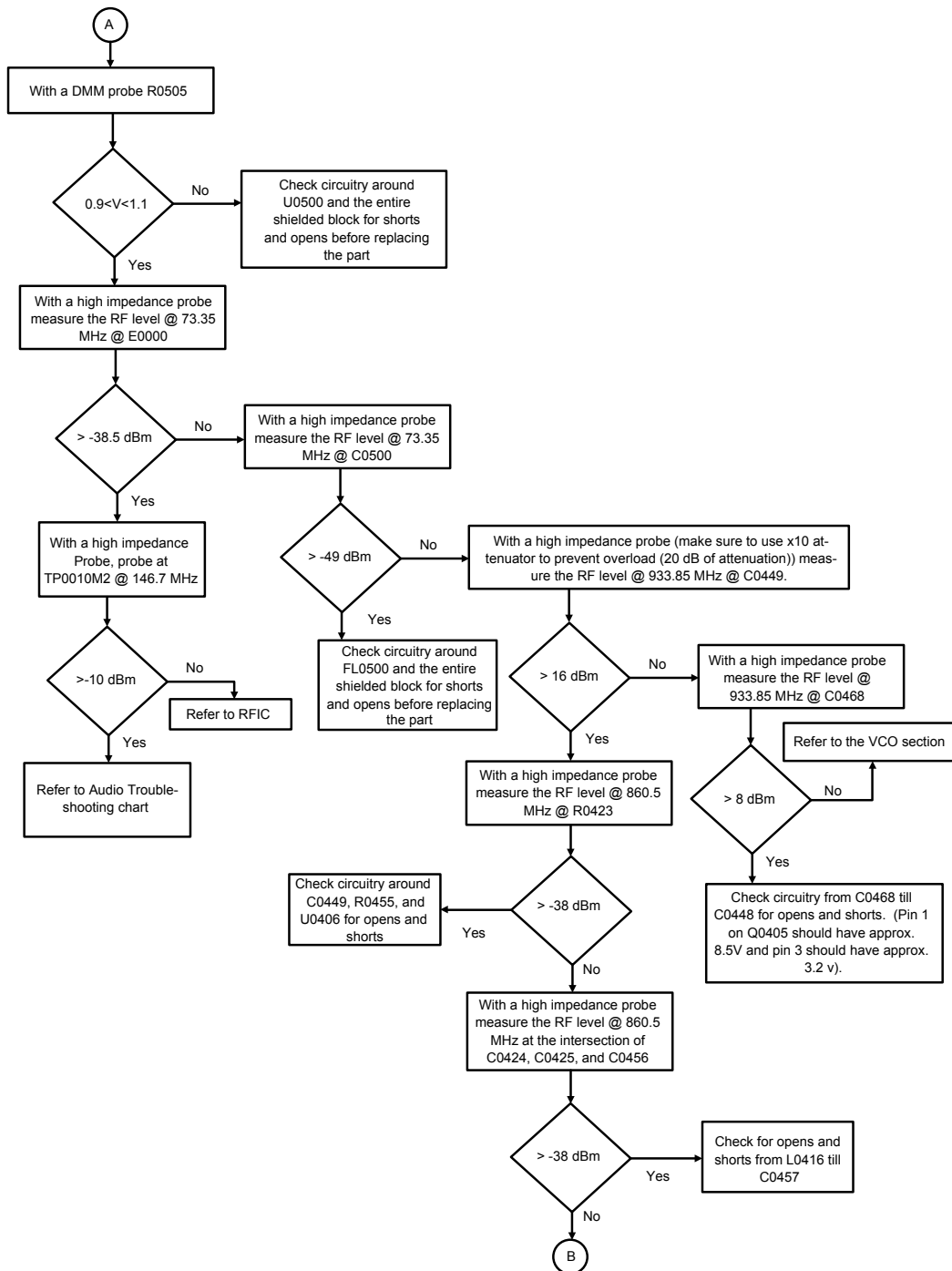
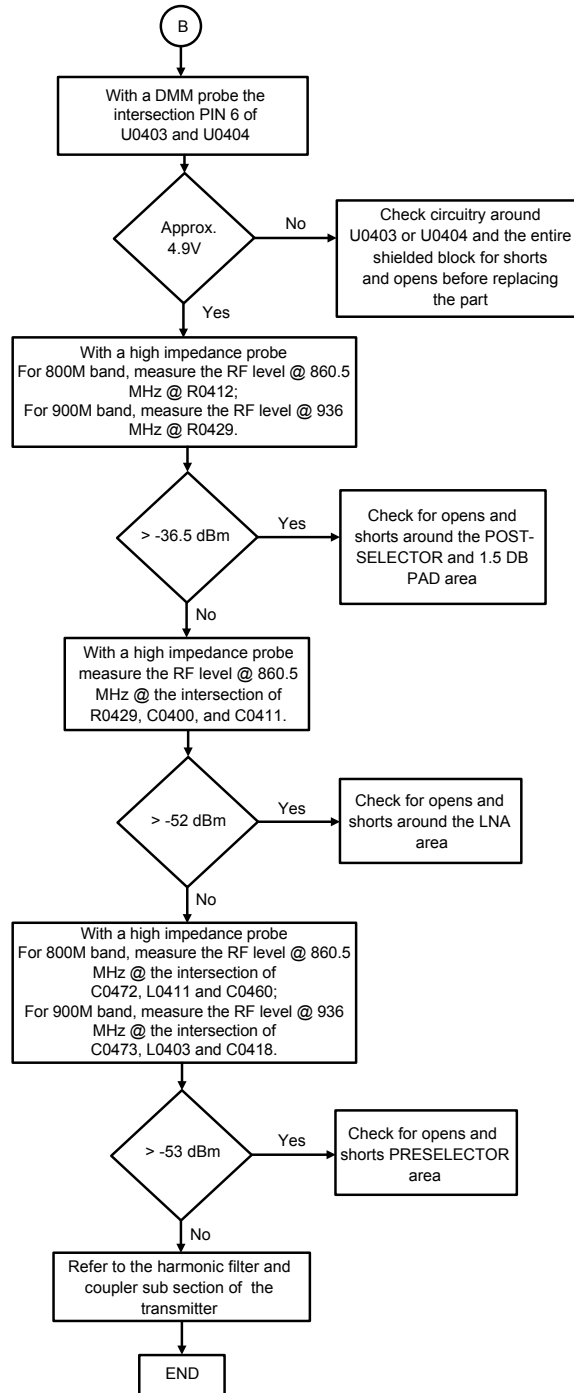

Figure 43: Troubleshooting Flow Chart for Receiver (Sheet 3 of 3)



7.3.2

Troubleshooting Flow Chart for Transmitter

VHF Low Power Service Information (25 W)

Figure 44: Troubleshooting Flow Chart for Transmitter

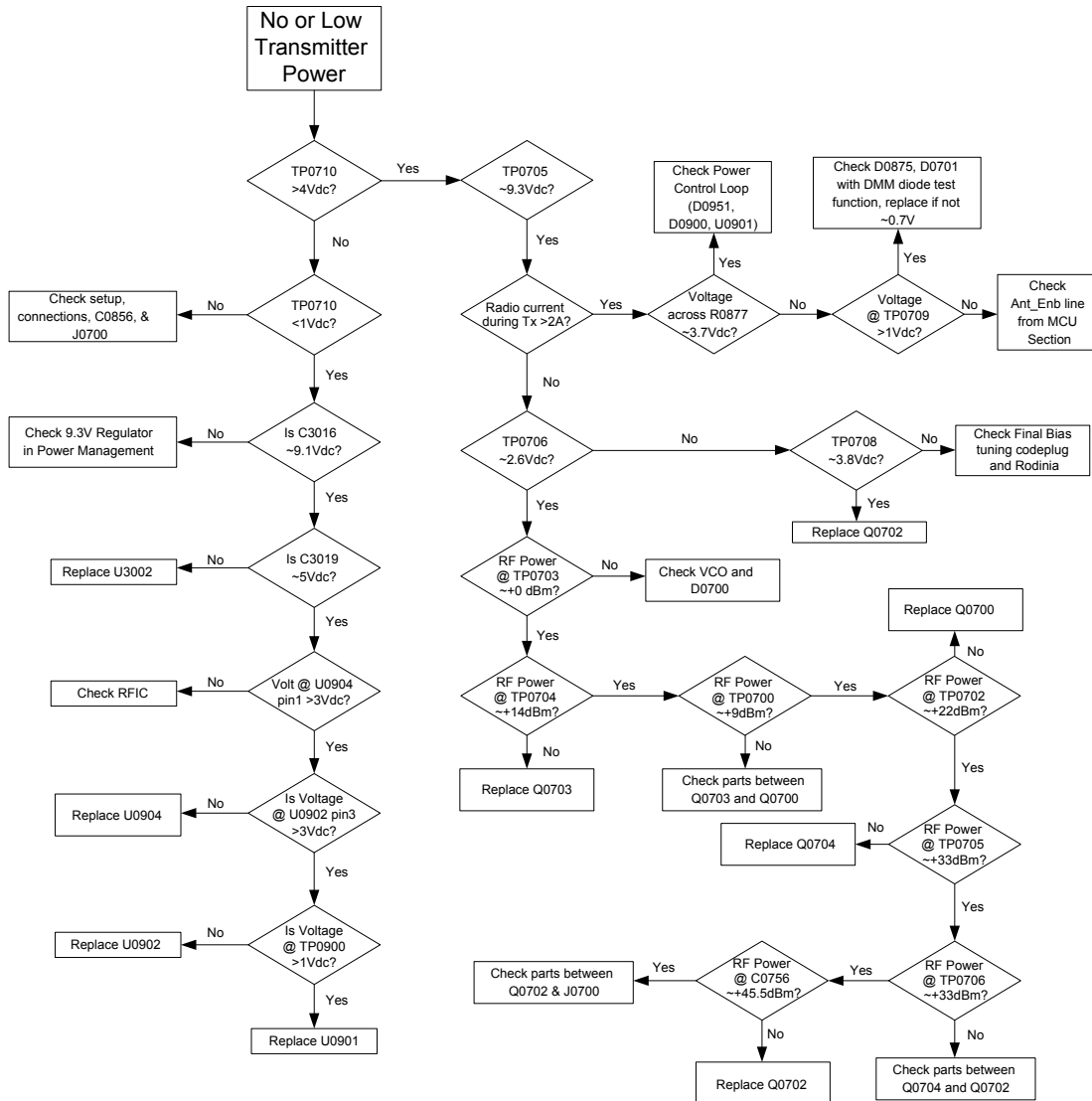

VHF High Power Service Information (45 W)

Figure 45: Troubleshooting Flow Chart for Transmitter

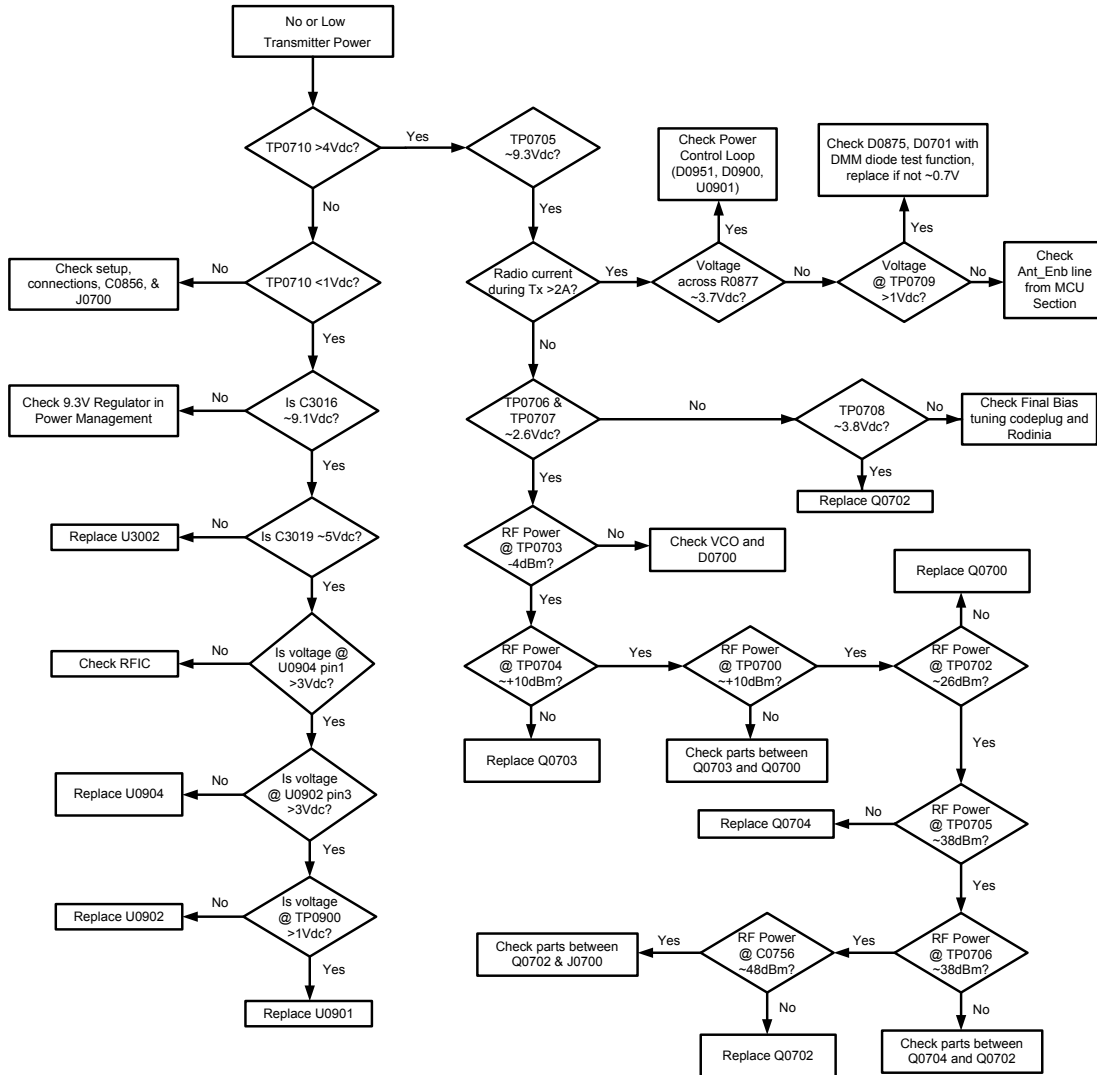

UHF1 Low Power Service Information (25 W)

Figure 46: Troubleshooting Flow Chart for Transmitter

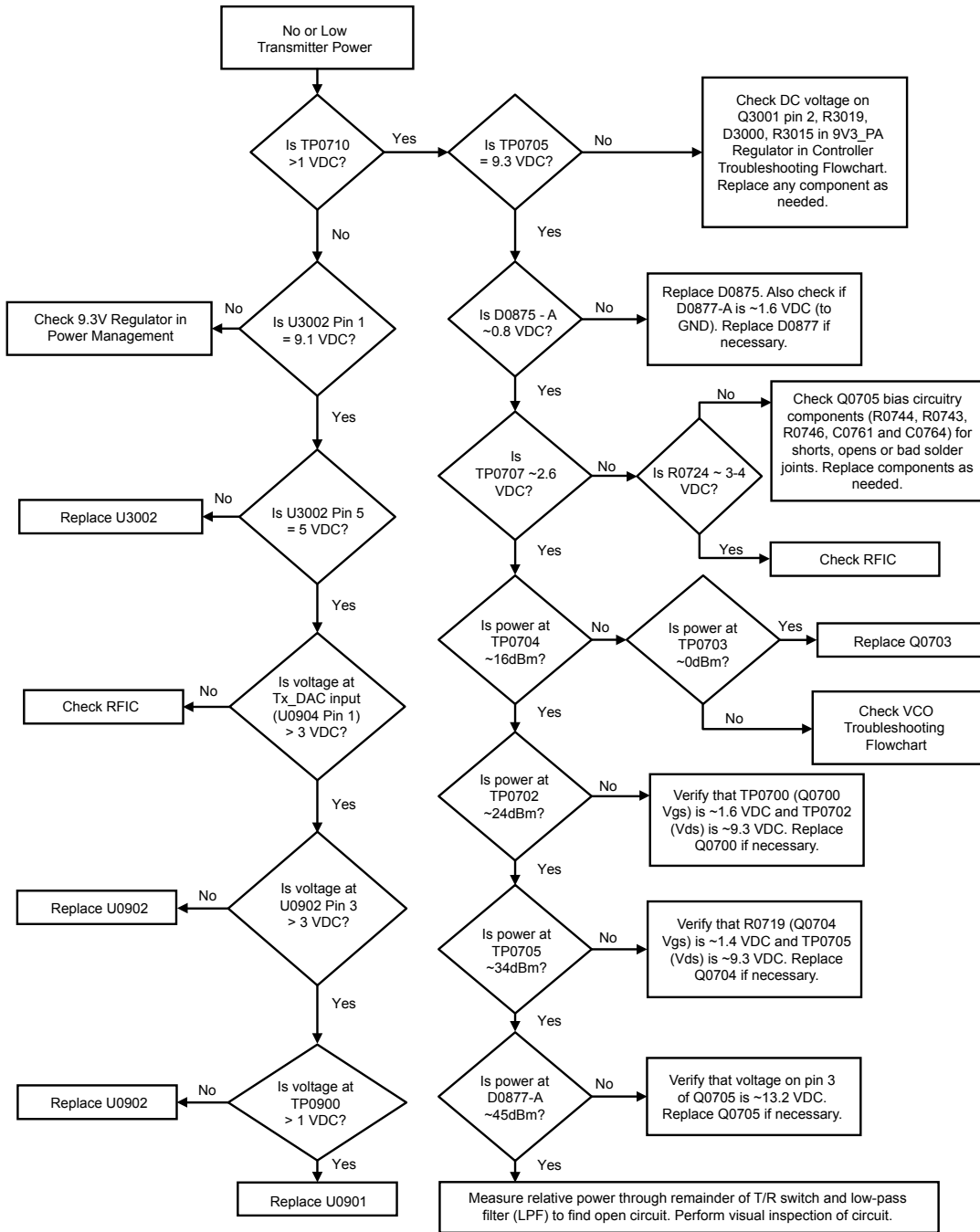

UHF1 High Power Service Information (40 W)

Figure 47: Troubleshooting Flow Chart for Transmitter

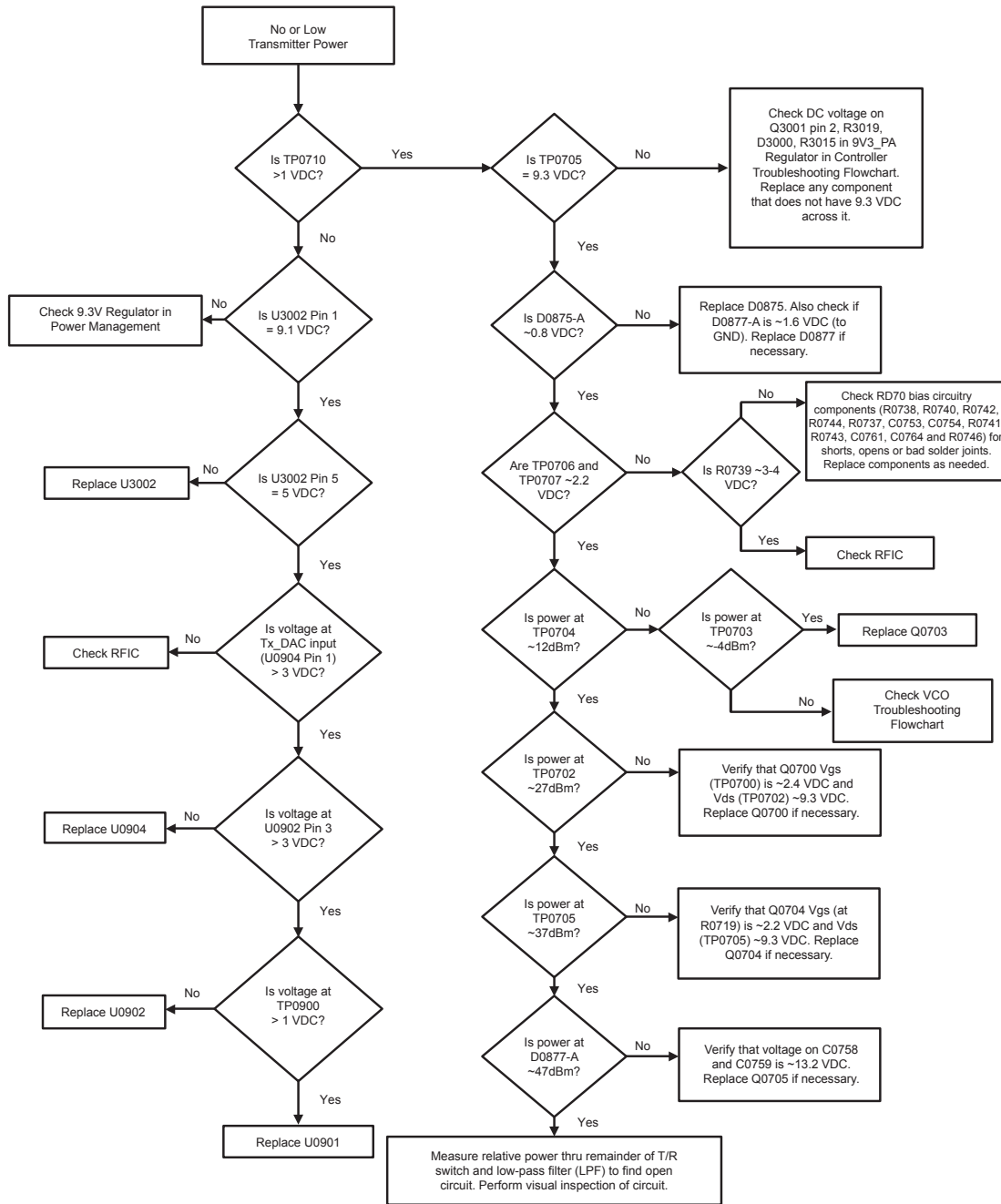

UHF2 Service Information (40 W)

Figure 48: Troubleshooting Flow Chart for Transmitter

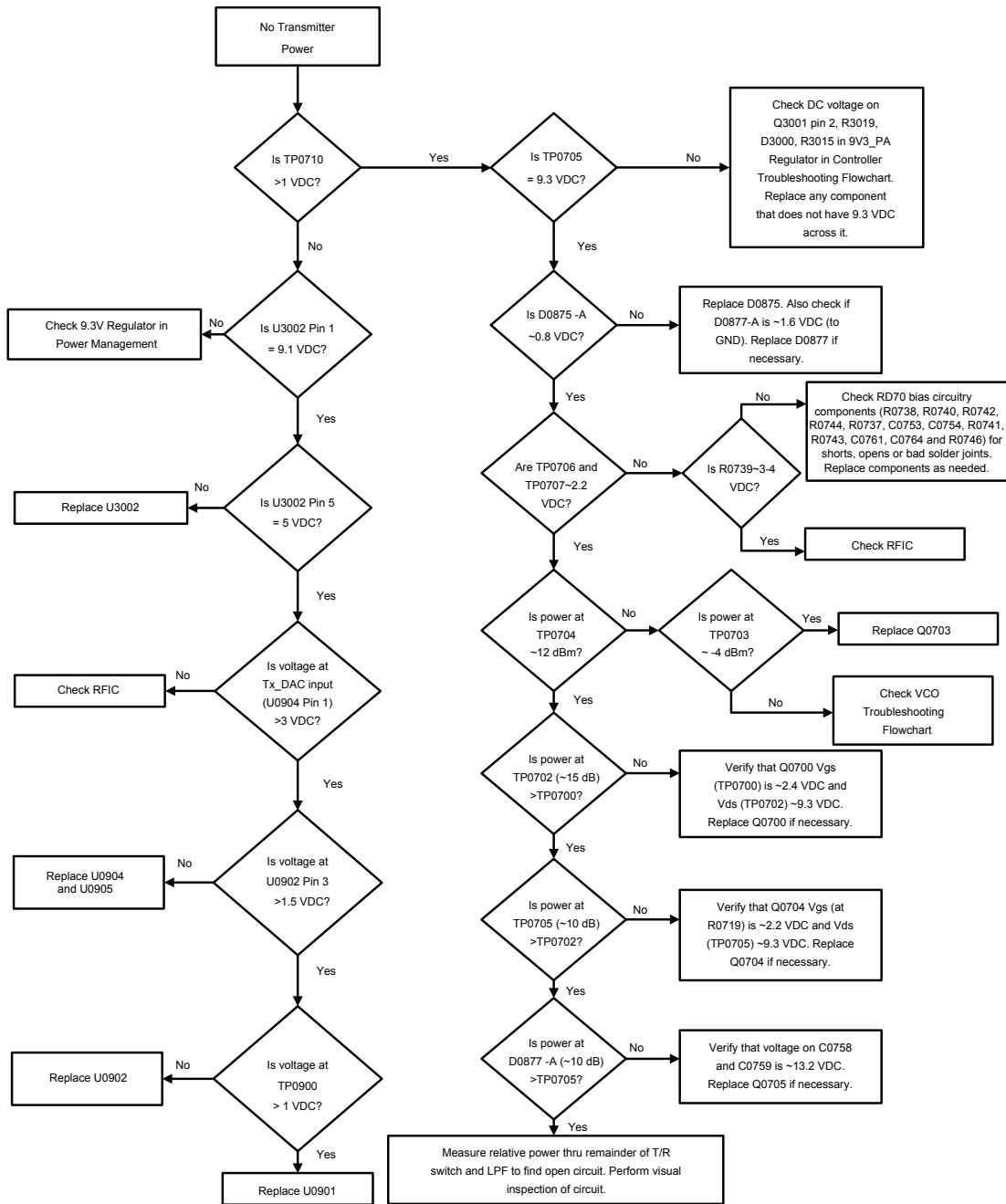

800 Band Service Information (38.5 W)

Figure 49: Troubleshooting Flow Chart for Transmitter

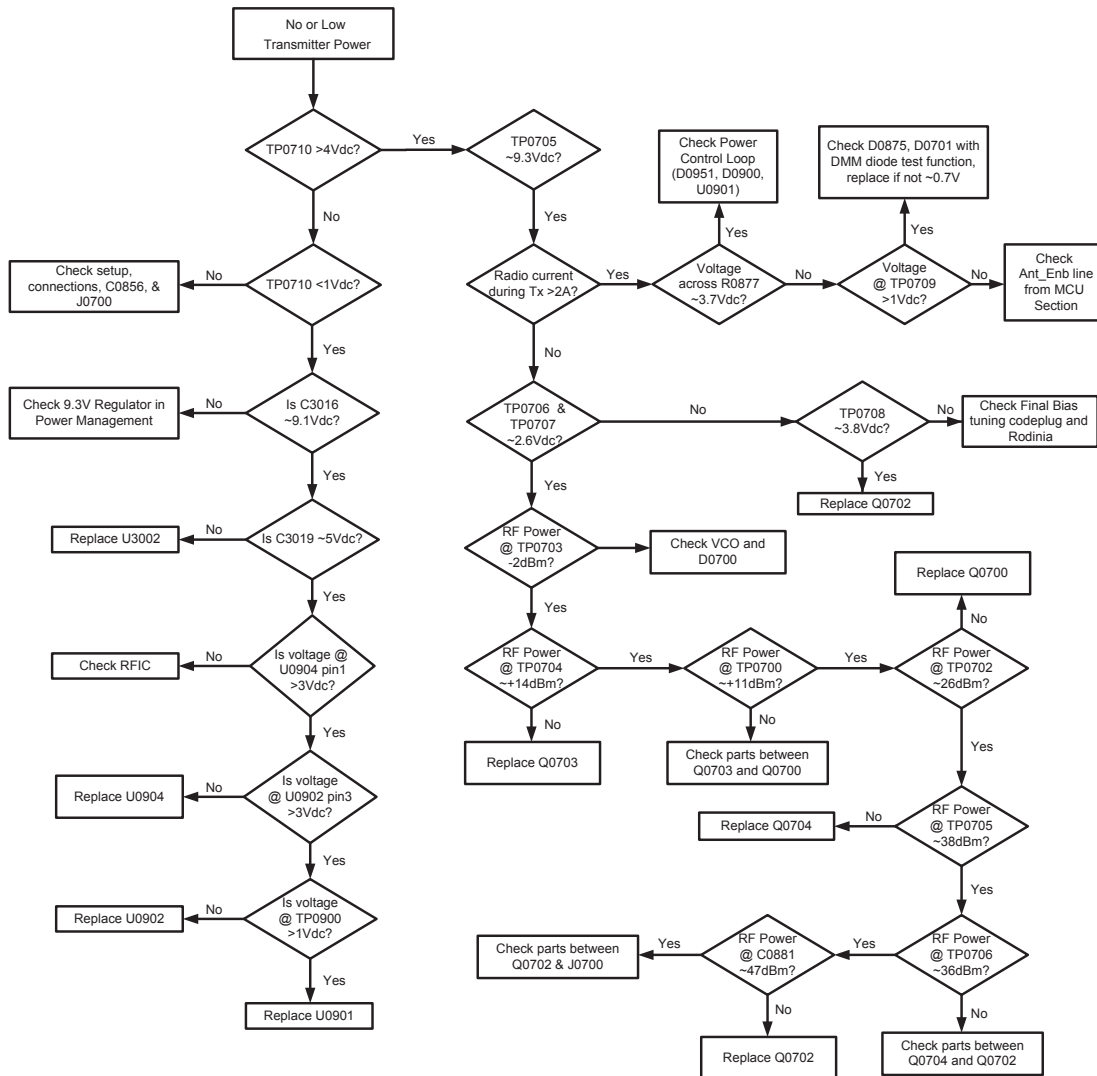

800/900 Band Service Information (10 W)

Figure 50: Troubleshooting Flow Chart for Transmitter

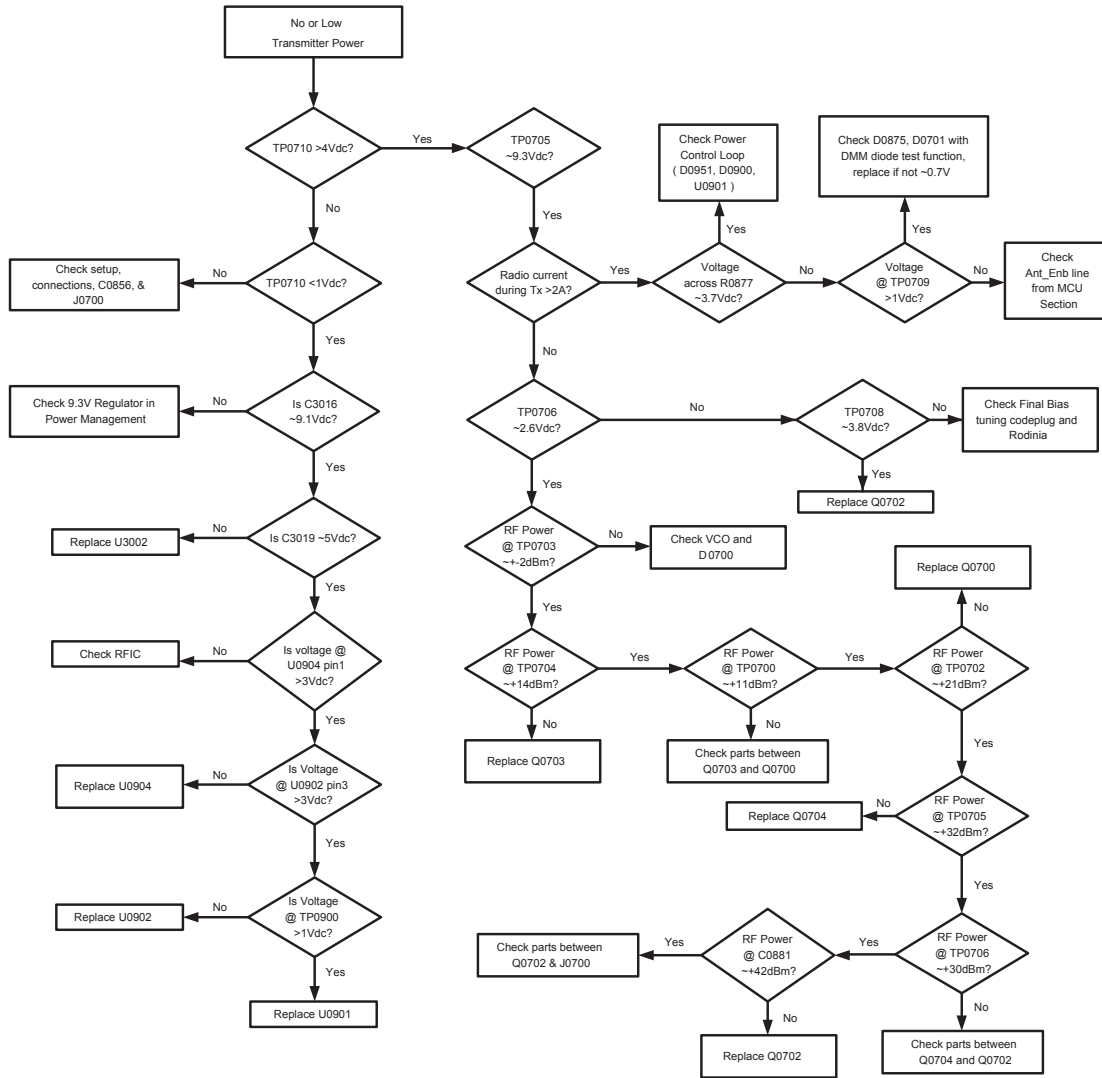

7.3.3

Troubleshooting Flow Chart for RFIC

VHF Low and High Power Service Information

Figure 51: Troubleshooting Flow Chart for RFIC (Sheet 1 of 5)

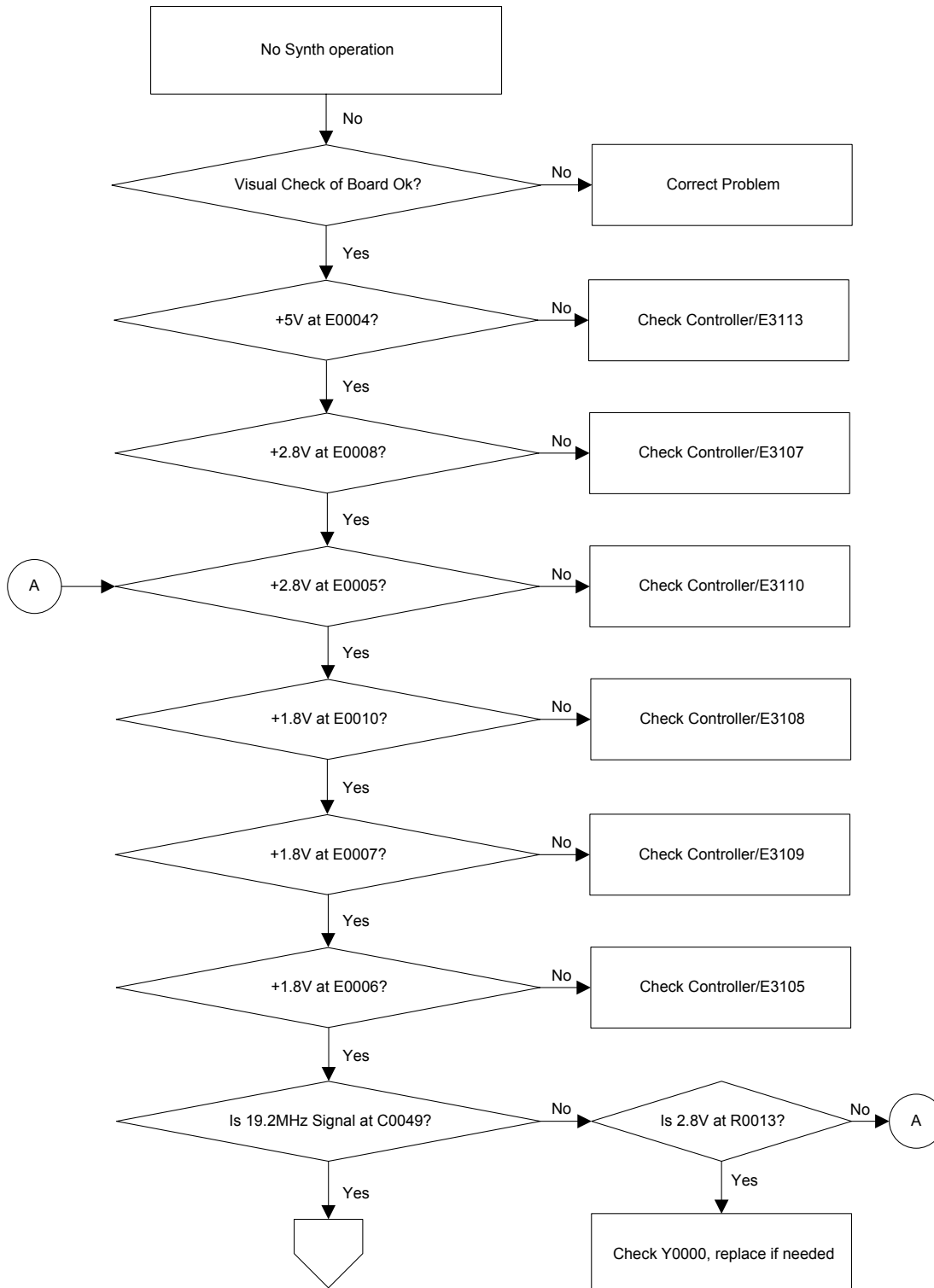

Figure 52: Troubleshooting Flow Chart for RFIC (Sheet 2 of 5)

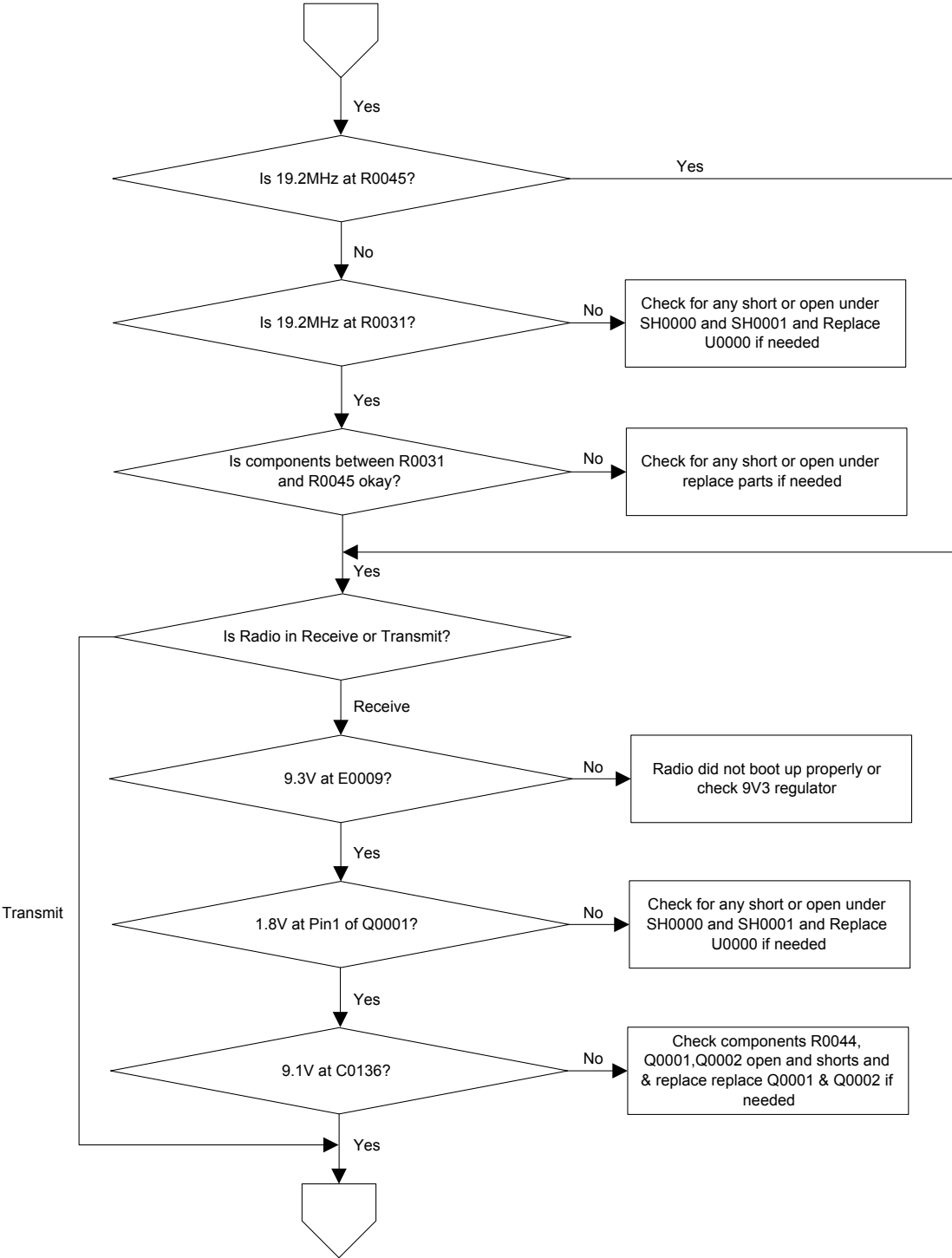

Figure 53: Troubleshooting Flow Chart for RFIC (Sheet 3 of 5)

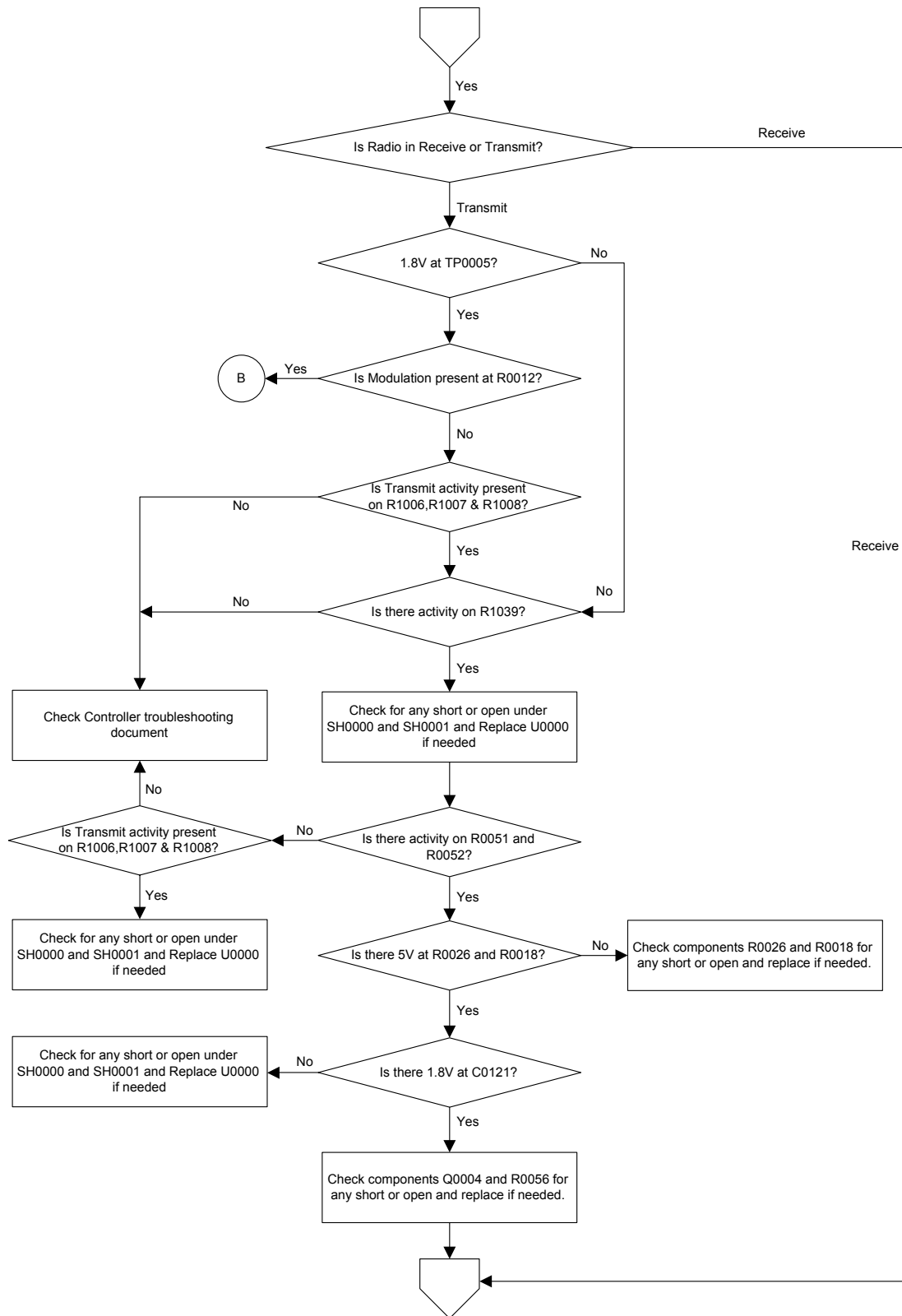

Figure 54: Troubleshooting Flow Chart for RFIC (Sheet 4 of 5)

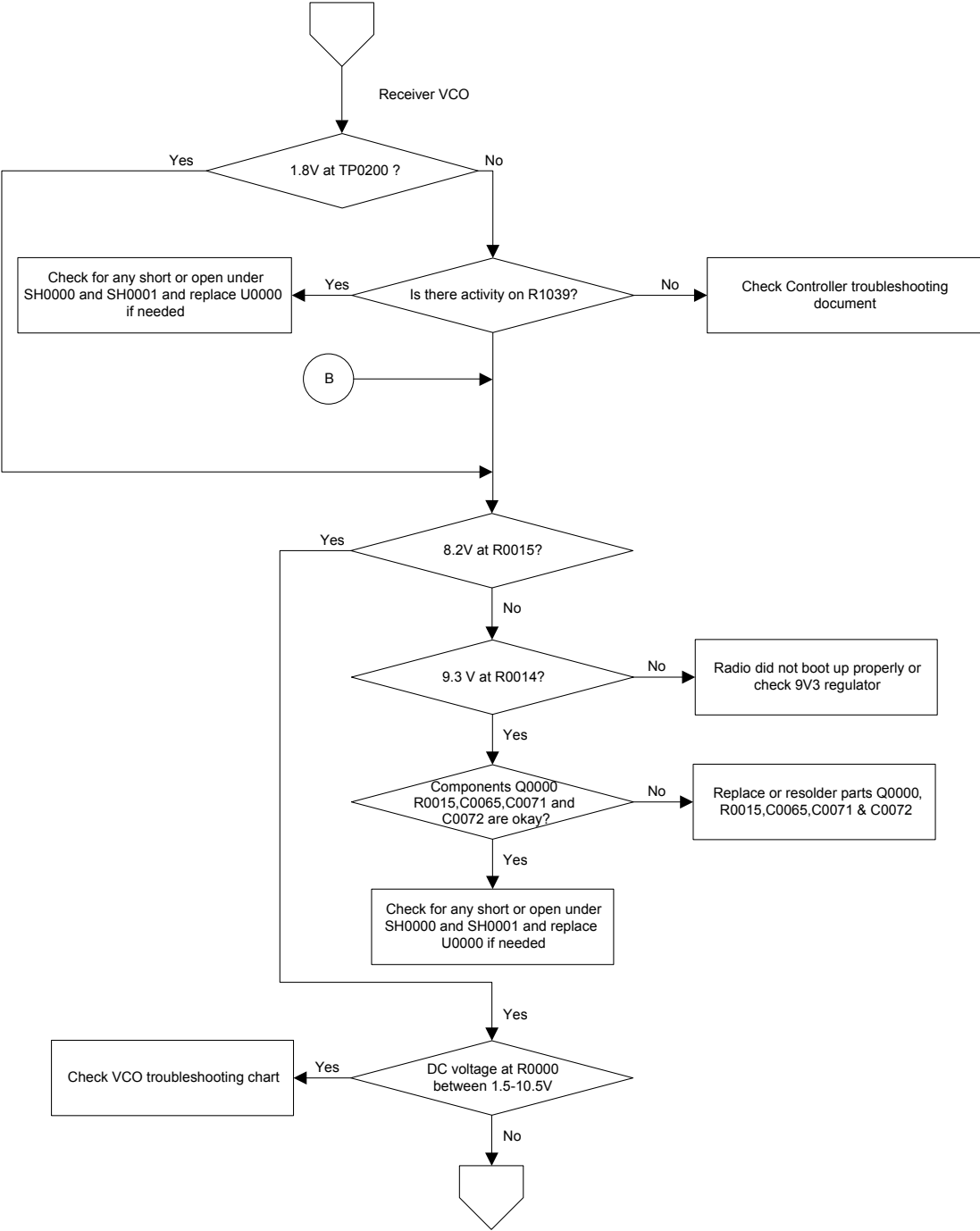
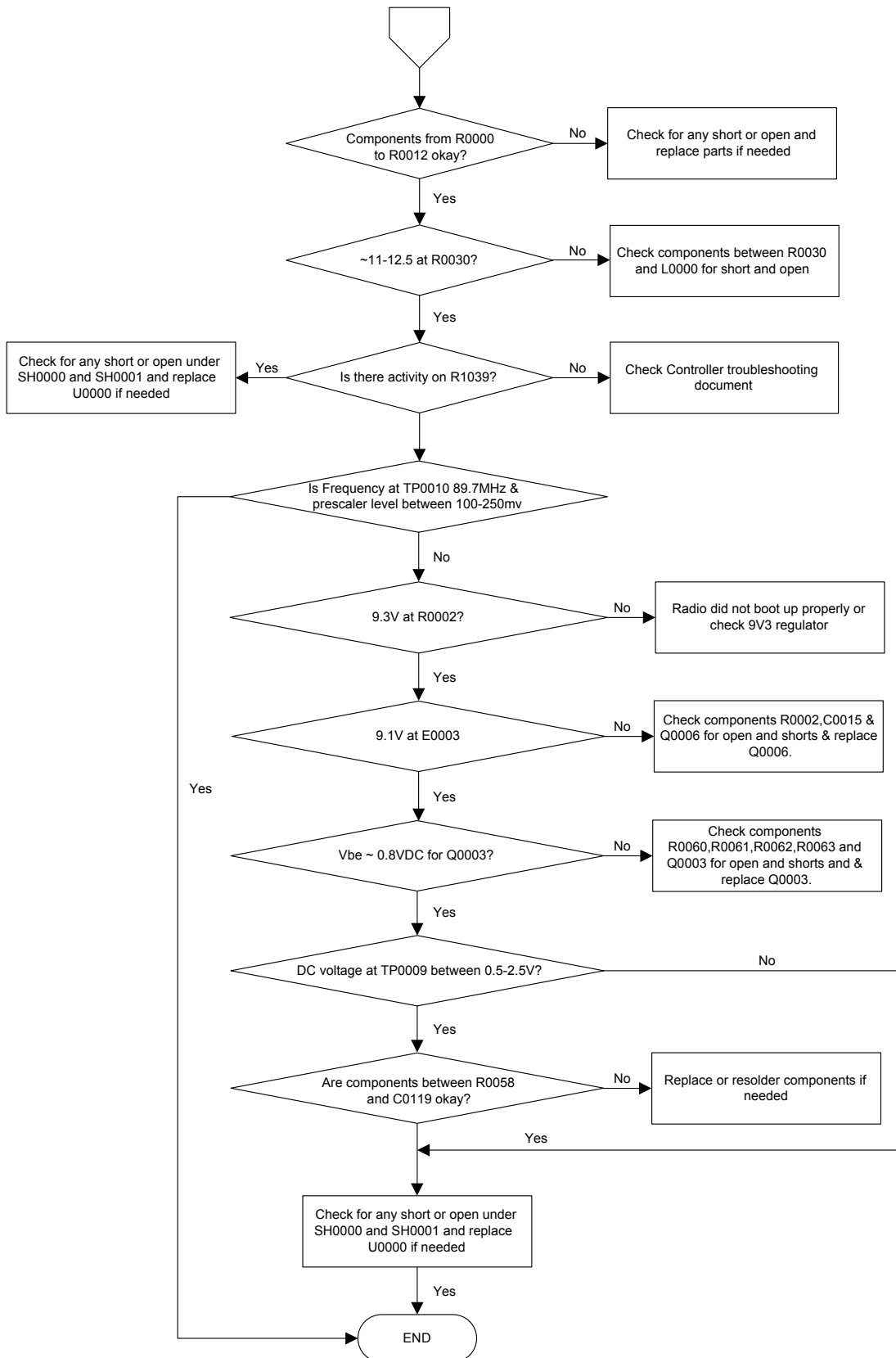

Figure 55: Troubleshooting Flow Chart for RFIC (Sheet 5 of 5)



UHF1 Low and High Power Service Information

Figure 56: Troubleshooting Flow Chart for RFIC (Sheet 1 of 5)

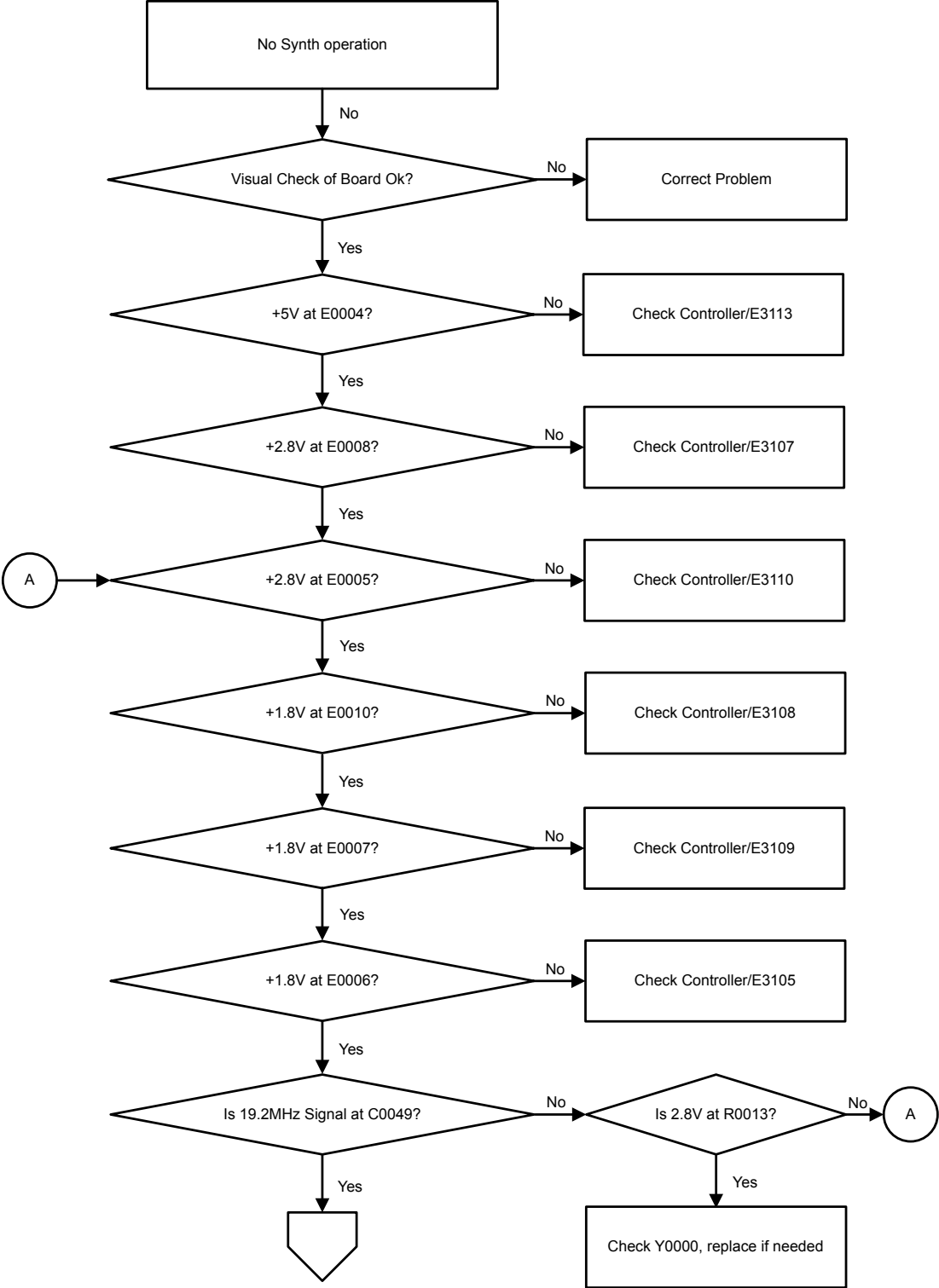

Figure 57: Troubleshooting Flow Chart for RFIC (Sheet 2 of 5)

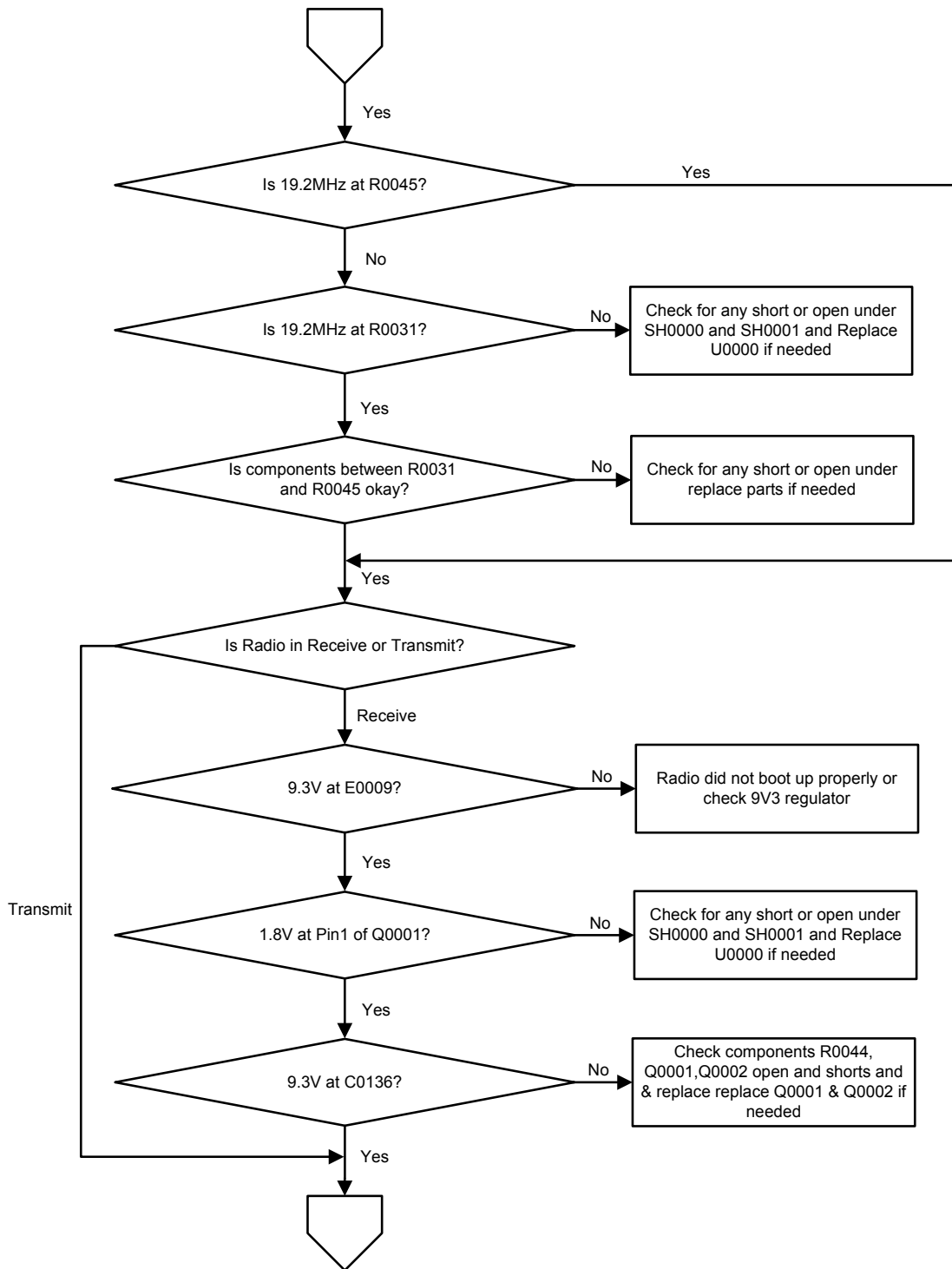

Figure 58: Troubleshooting Flow Chart for RFIC (Sheet 3 of 5)

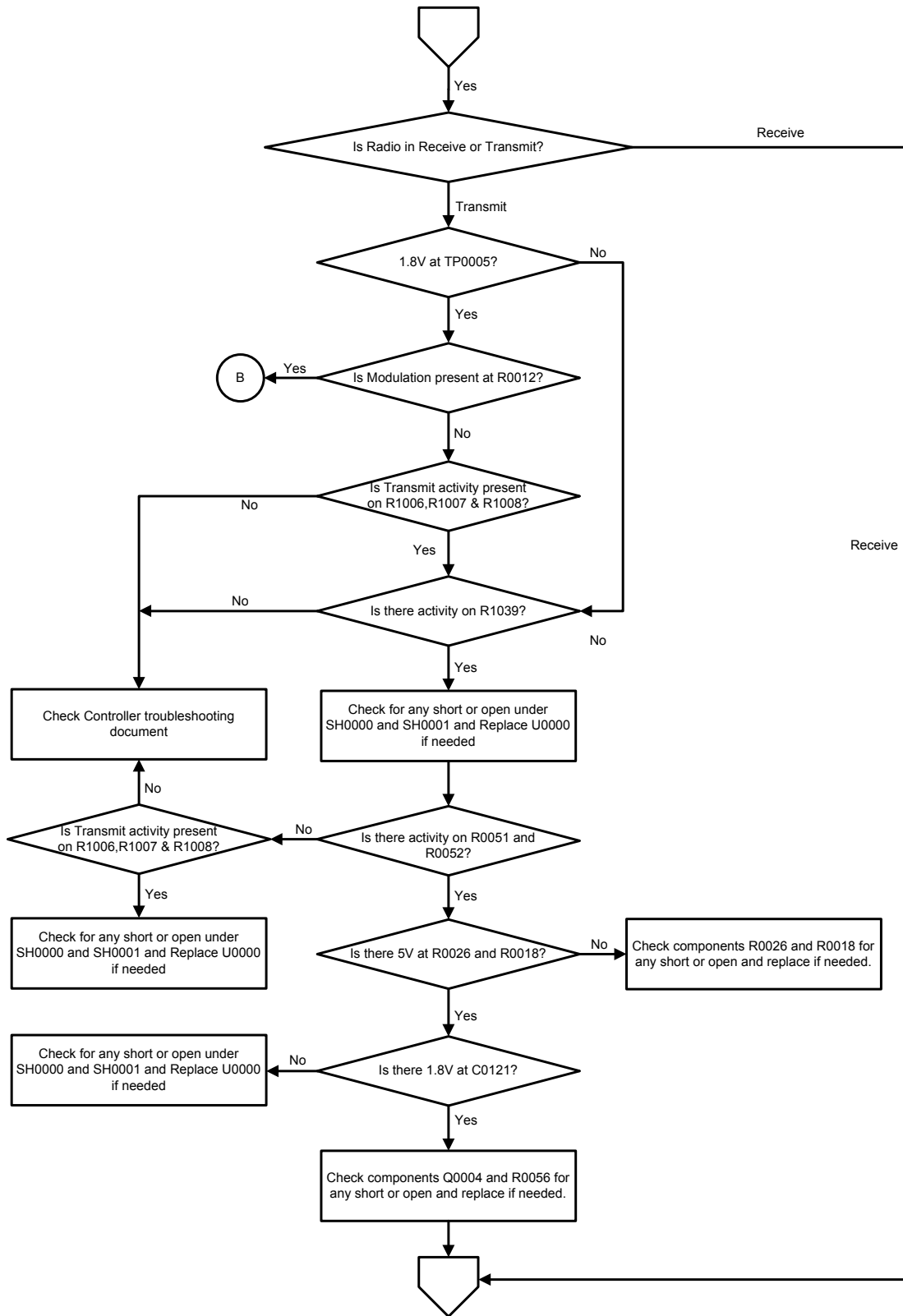

Figure 59: Troubleshooting Flow Chart for RFIC (Sheet 4 of 5)

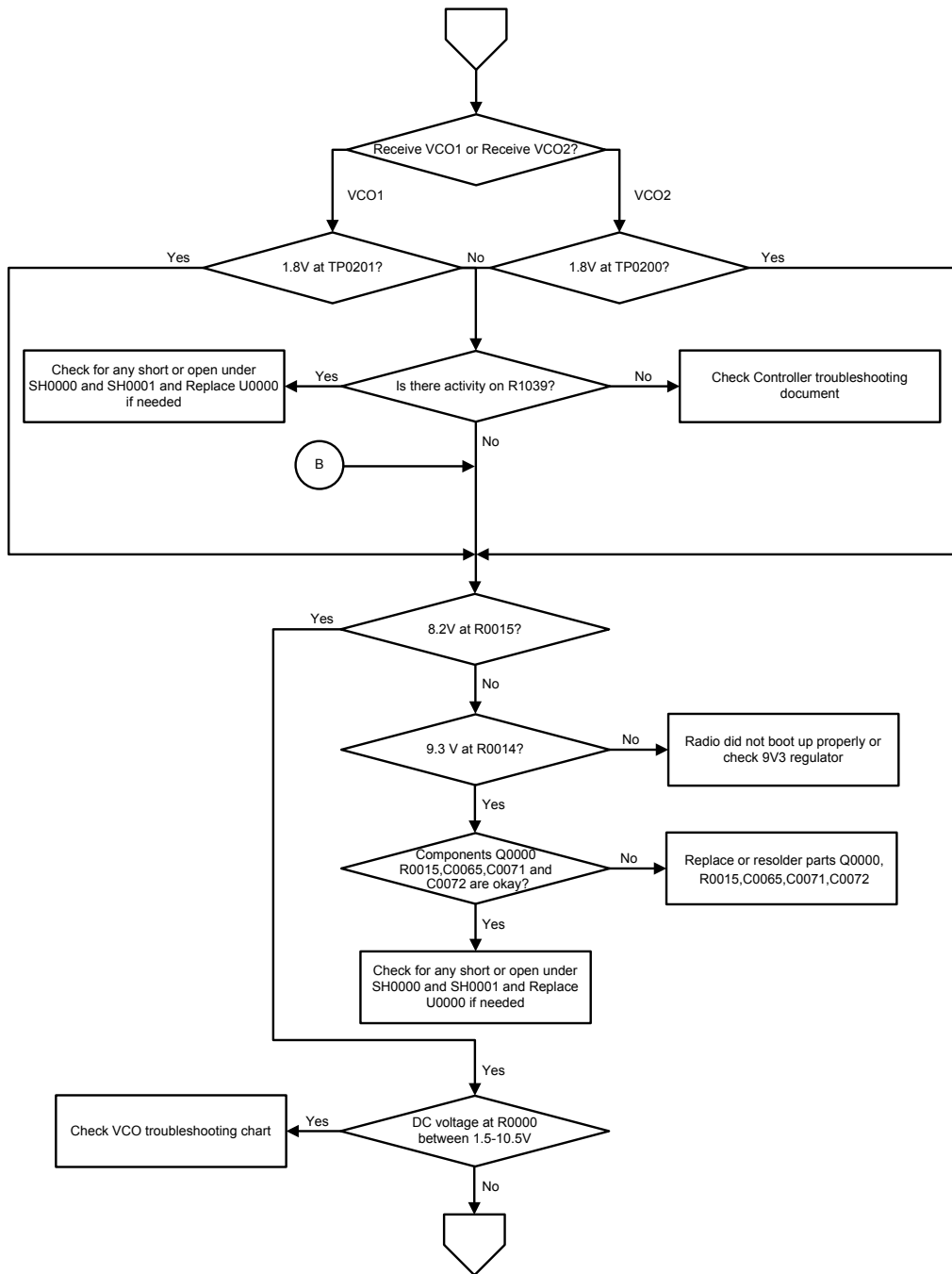
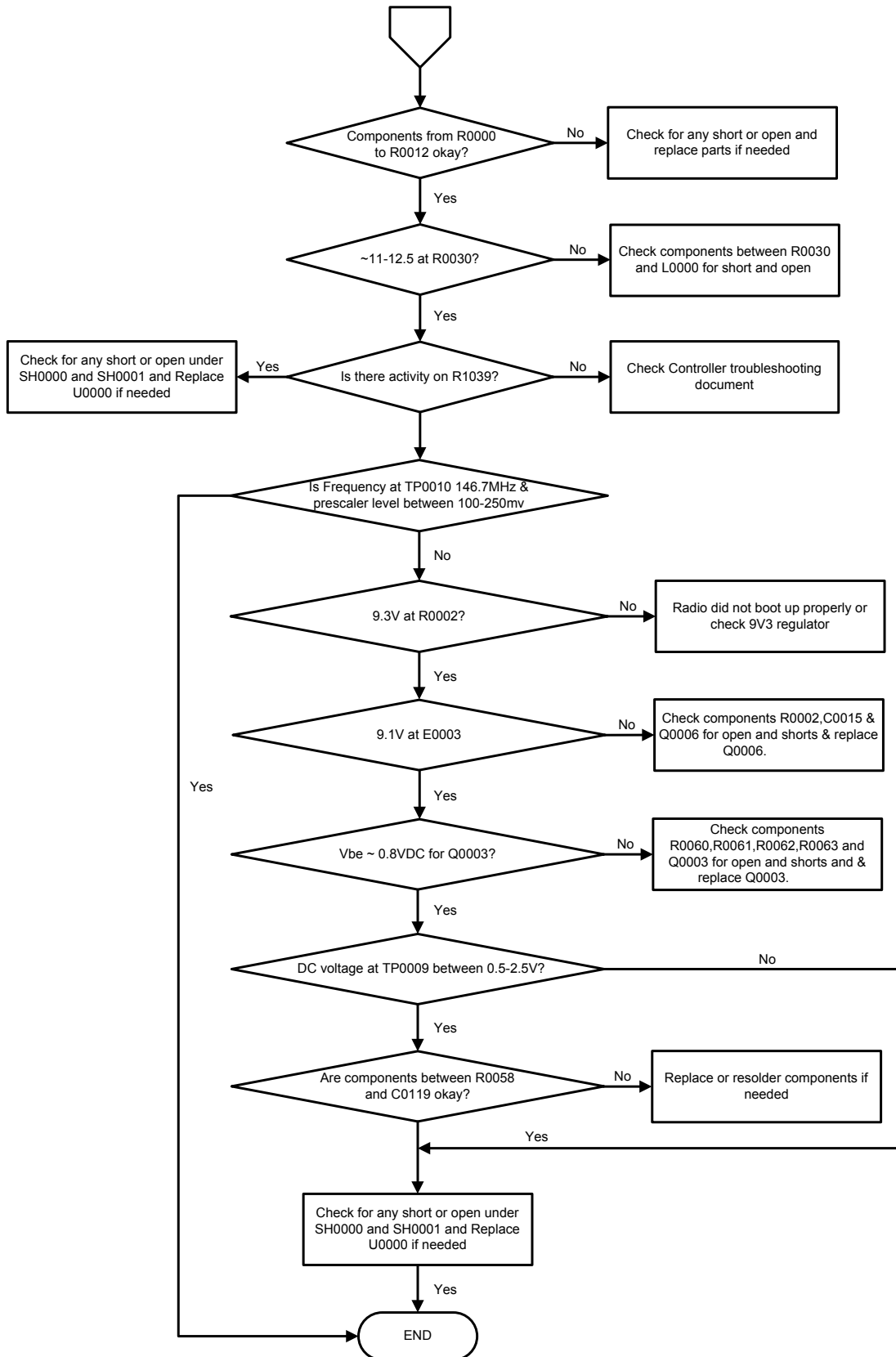

Figure 60: Troubleshooting Flow Chart for RFIC (Sheet 5 of 5)



UHF2 Service Information

Figure 61: Troubleshooting Flow Chart for RFIC (Sheet 1 of 5)

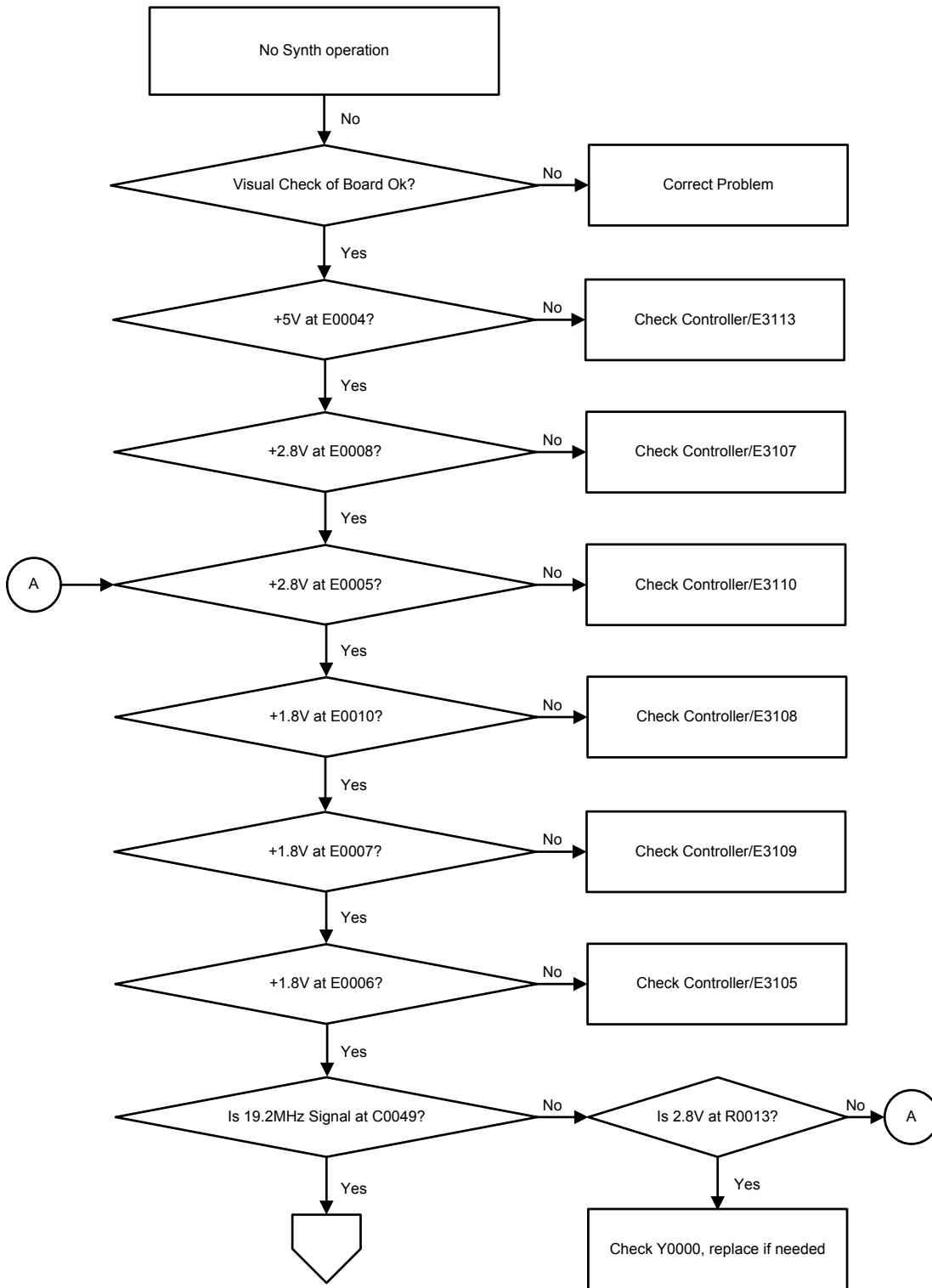

Figure 62: Troubleshooting Flow Chart for RFIC (Sheet 2 of 5)

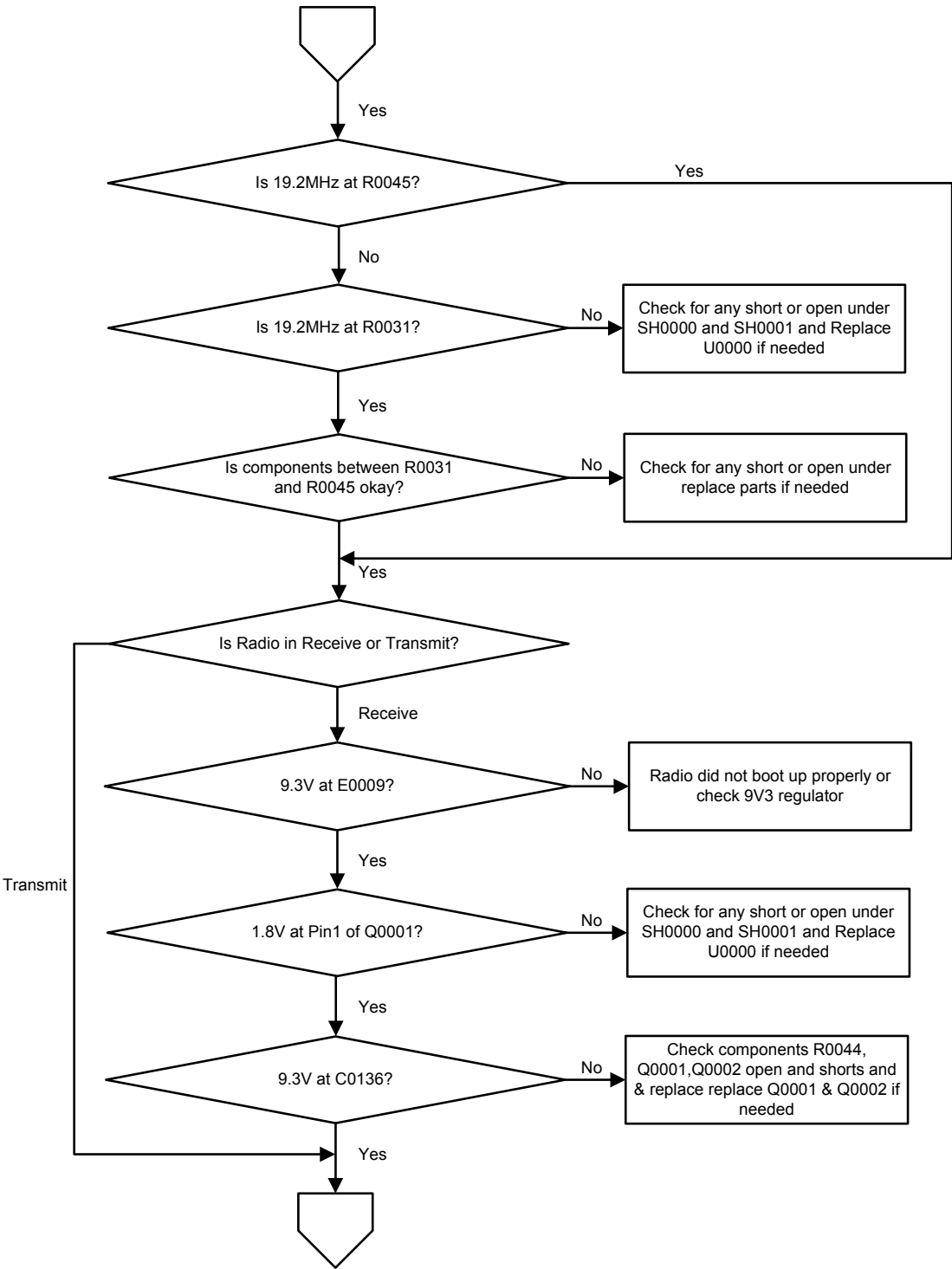

Figure 63: Troubleshooting Flow Chart for RFIC (Sheet 3 of 5)

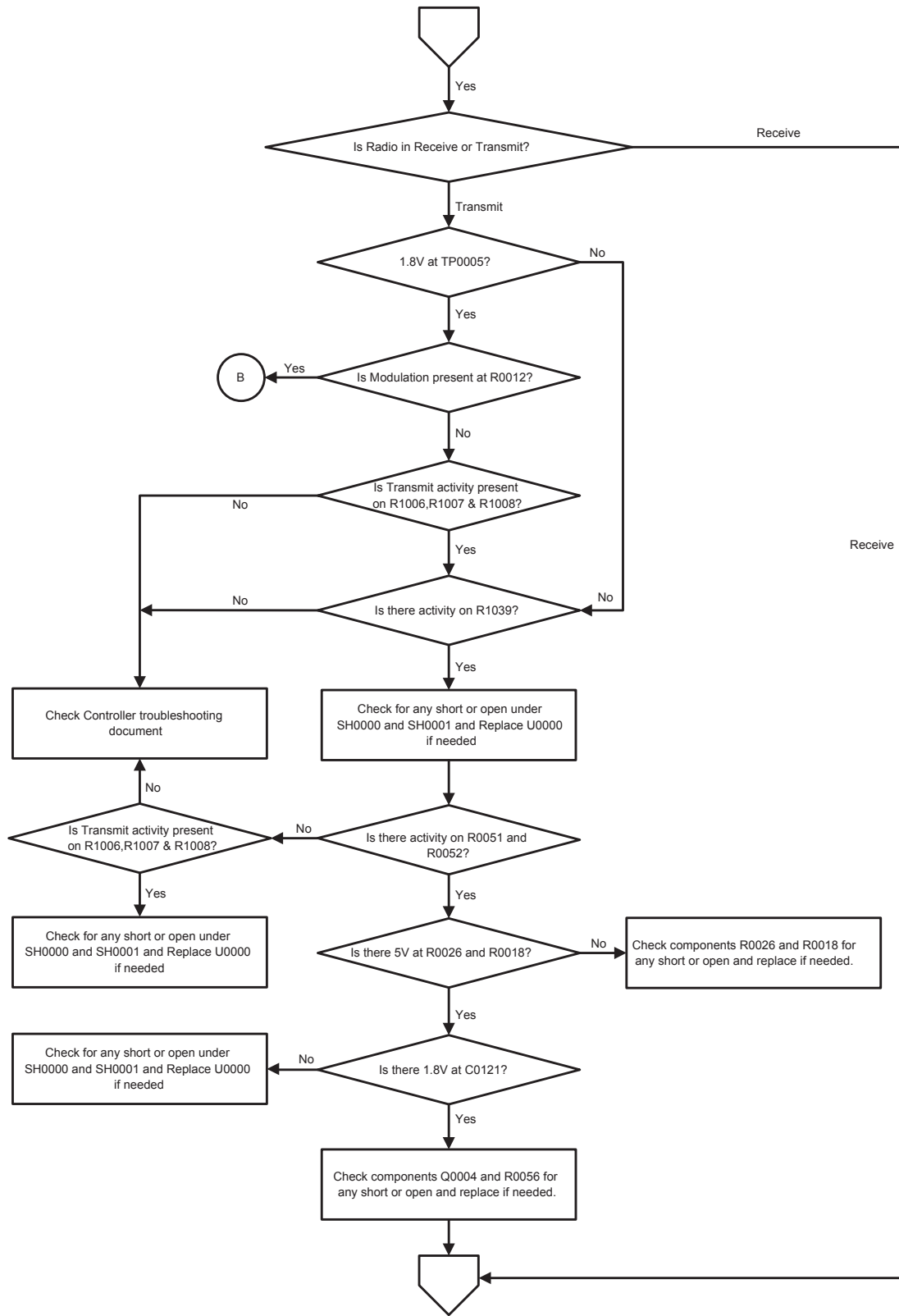

Figure 64: Troubleshooting Flow Chart for RFIC (Sheet 4 of 5)

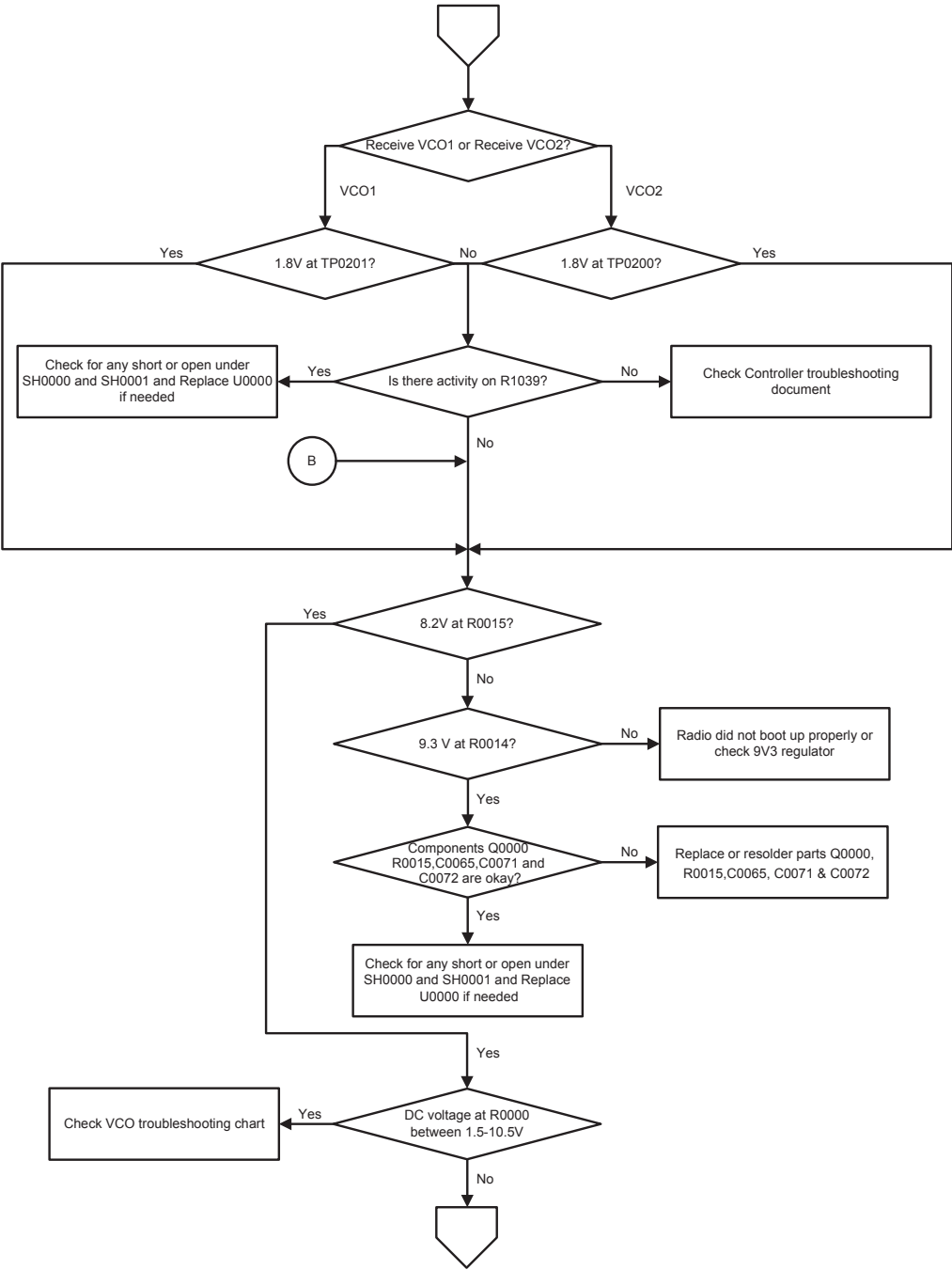
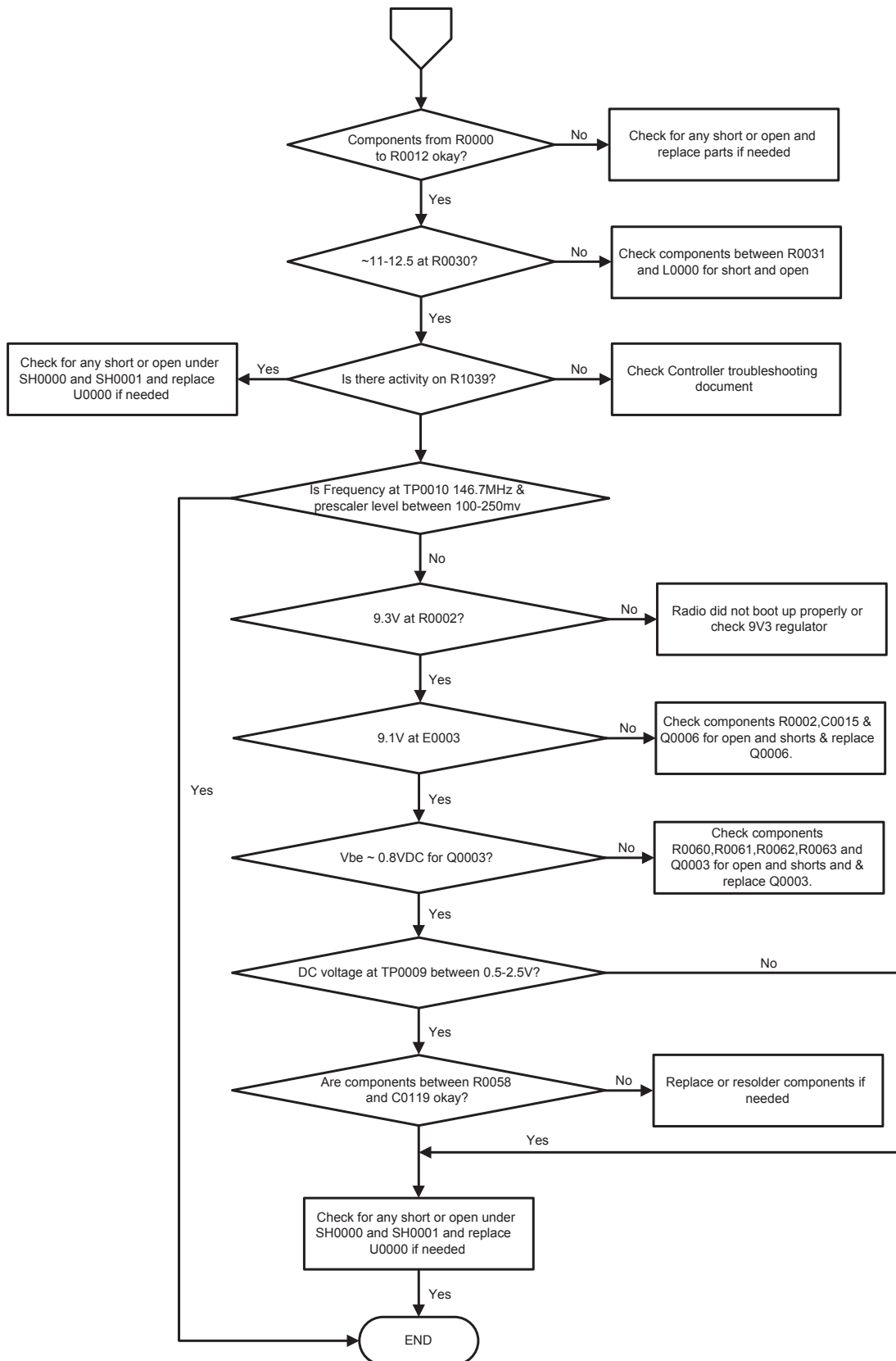

Figure 65: Troubleshooting Flow Chart for RFIC (Sheet 5 of 5)



800/900 Band Service Information

Figure 66: Troubleshooting Flow Chart for RFIC (Sheet 1 of 5)

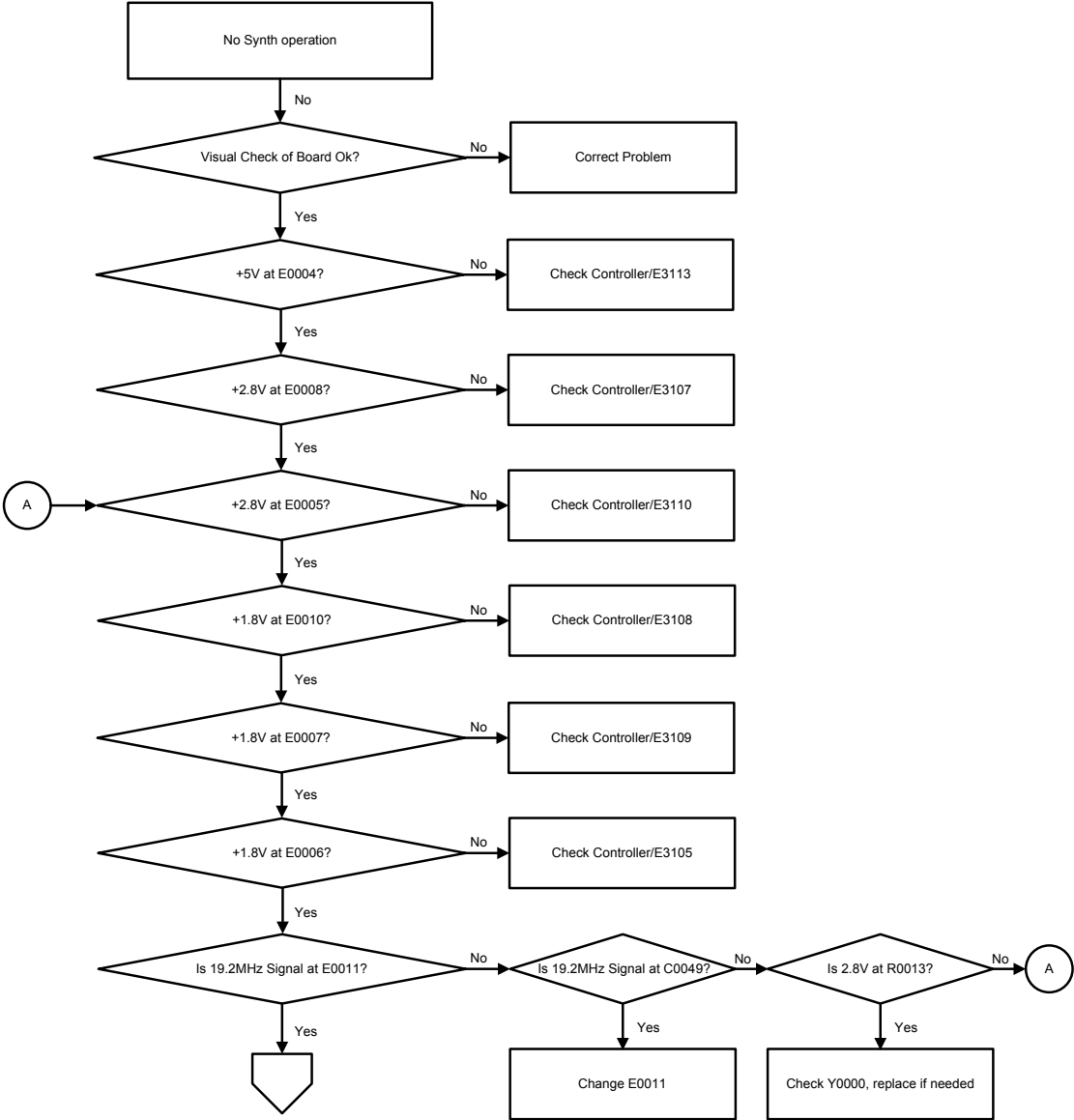

Figure 67: Troubleshooting Flow Chart for RFIC (Sheet 2 of 5)

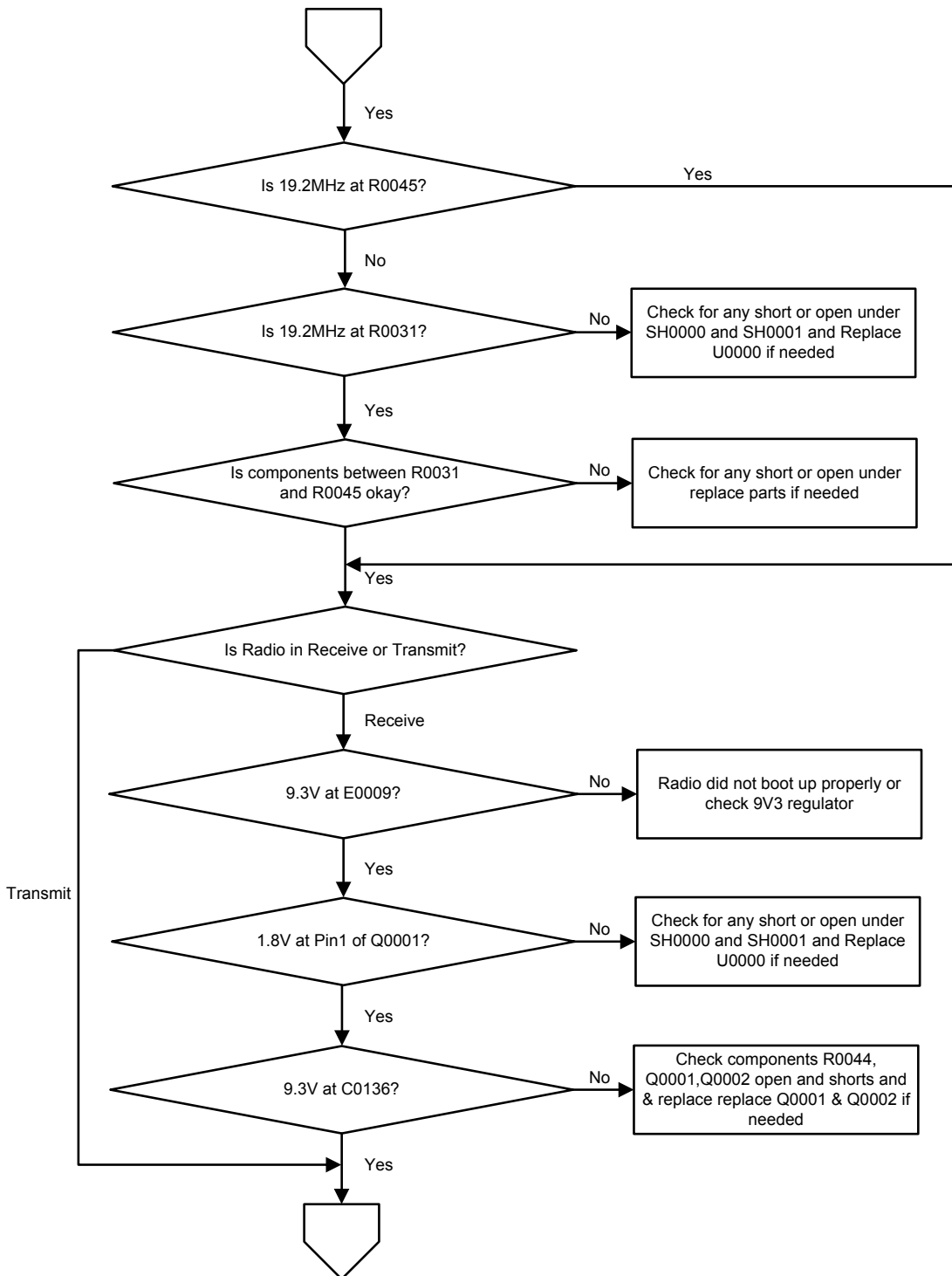

Figure 68: Troubleshooting Flow Chart for RFIC (Sheet 3 of 5)

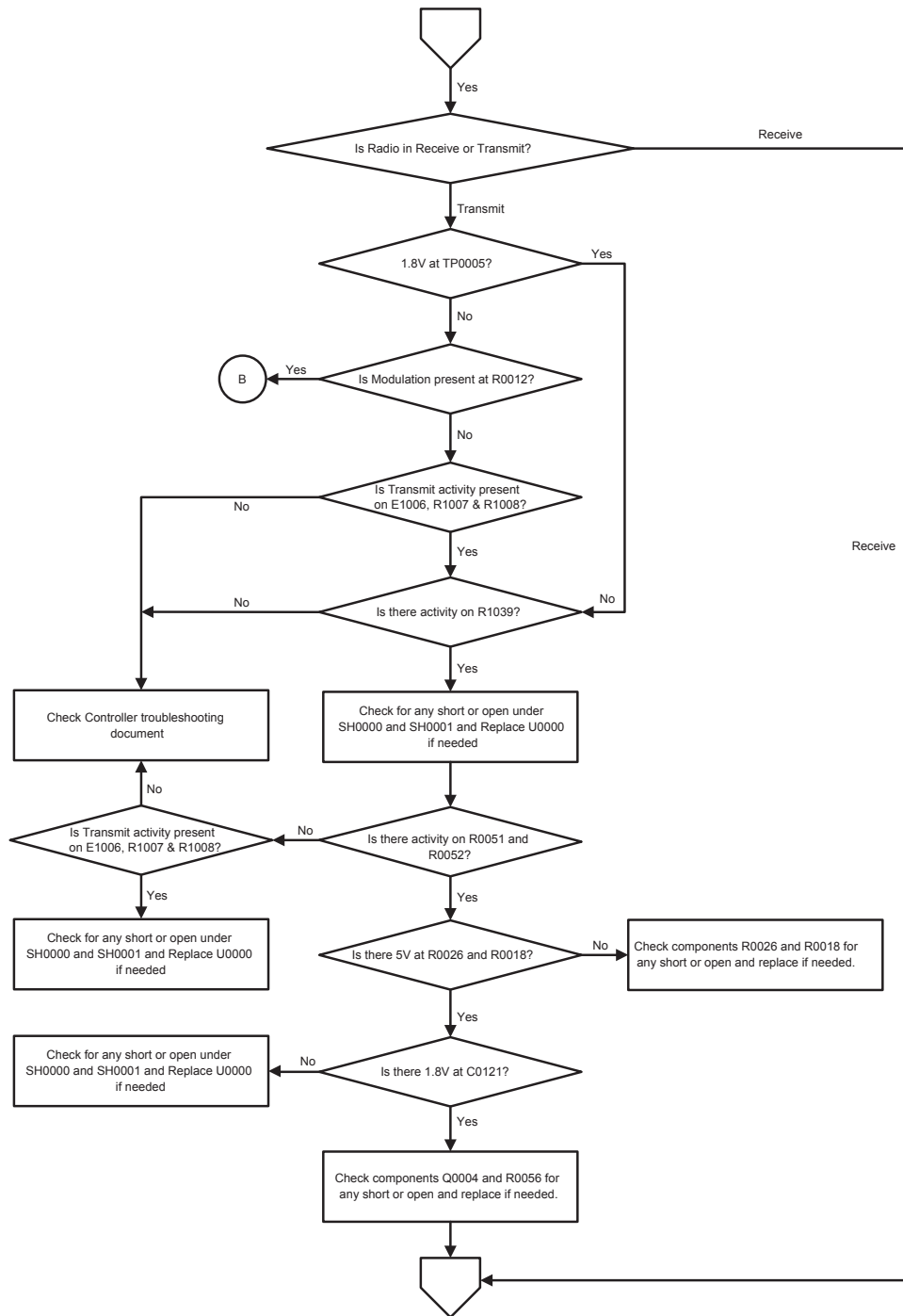

Figure 69: Troubleshooting Flow Chart for RFIC (Sheet 4 of 5)

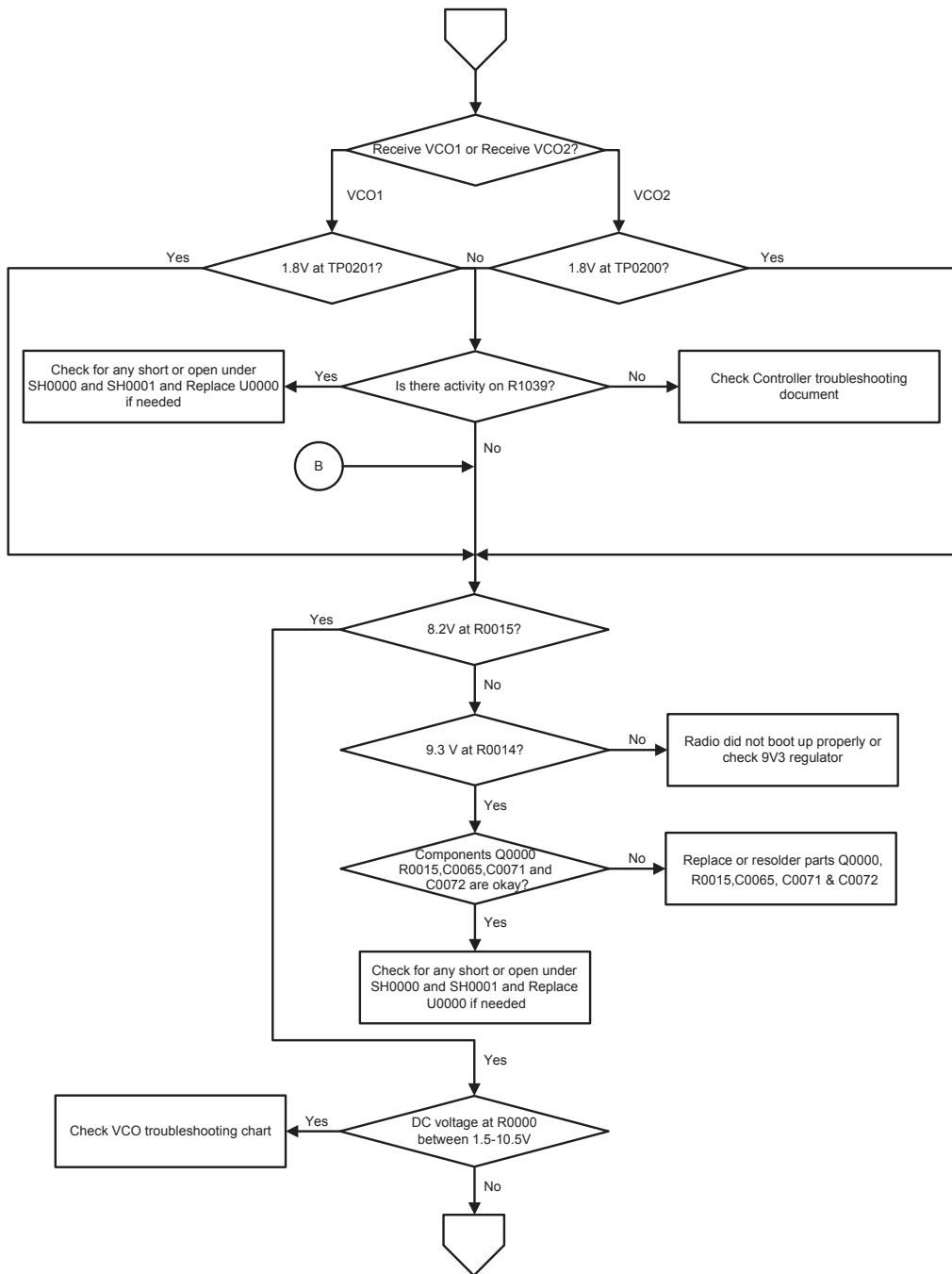
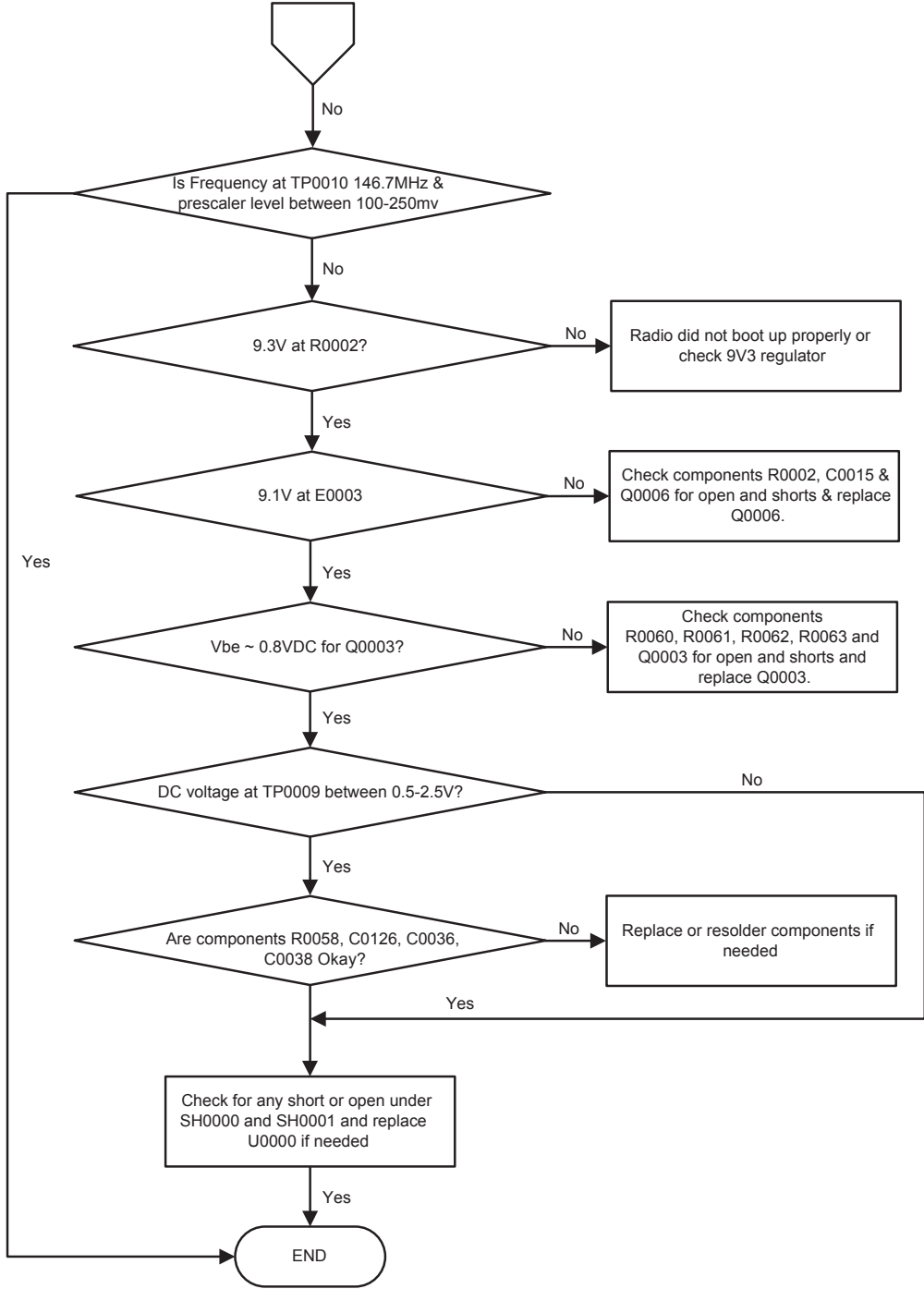

Figure 70: Troubleshooting Flow Chart for RFIC (Sheet 5 of 5)



7.3.4 Troubleshooting Flow Chart for Rx VCO

VHF Low and High Power Service Information

Figure 71: Troubleshooting Flow Chart for Rx VCO (Sheet 1 of 2)

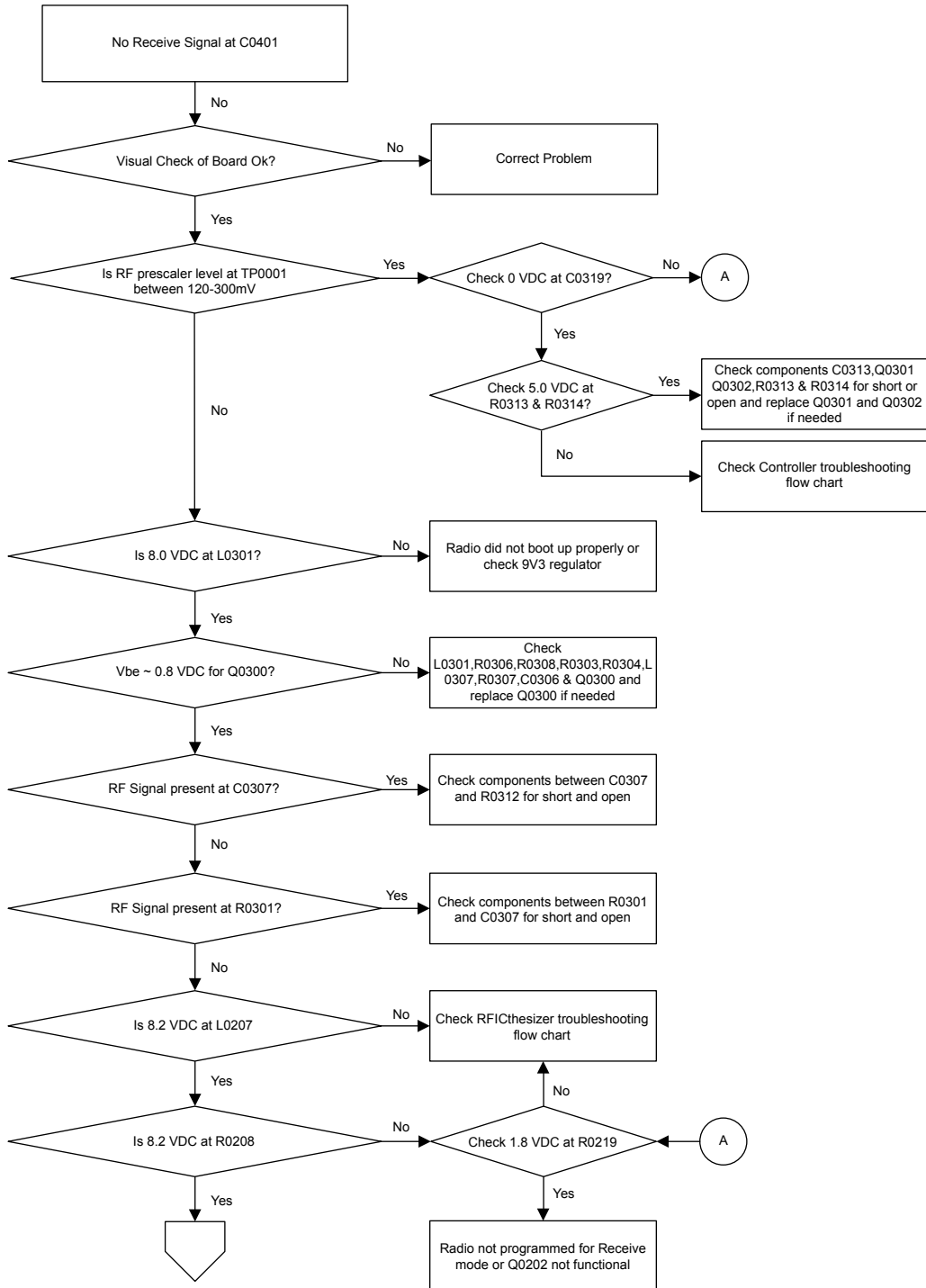
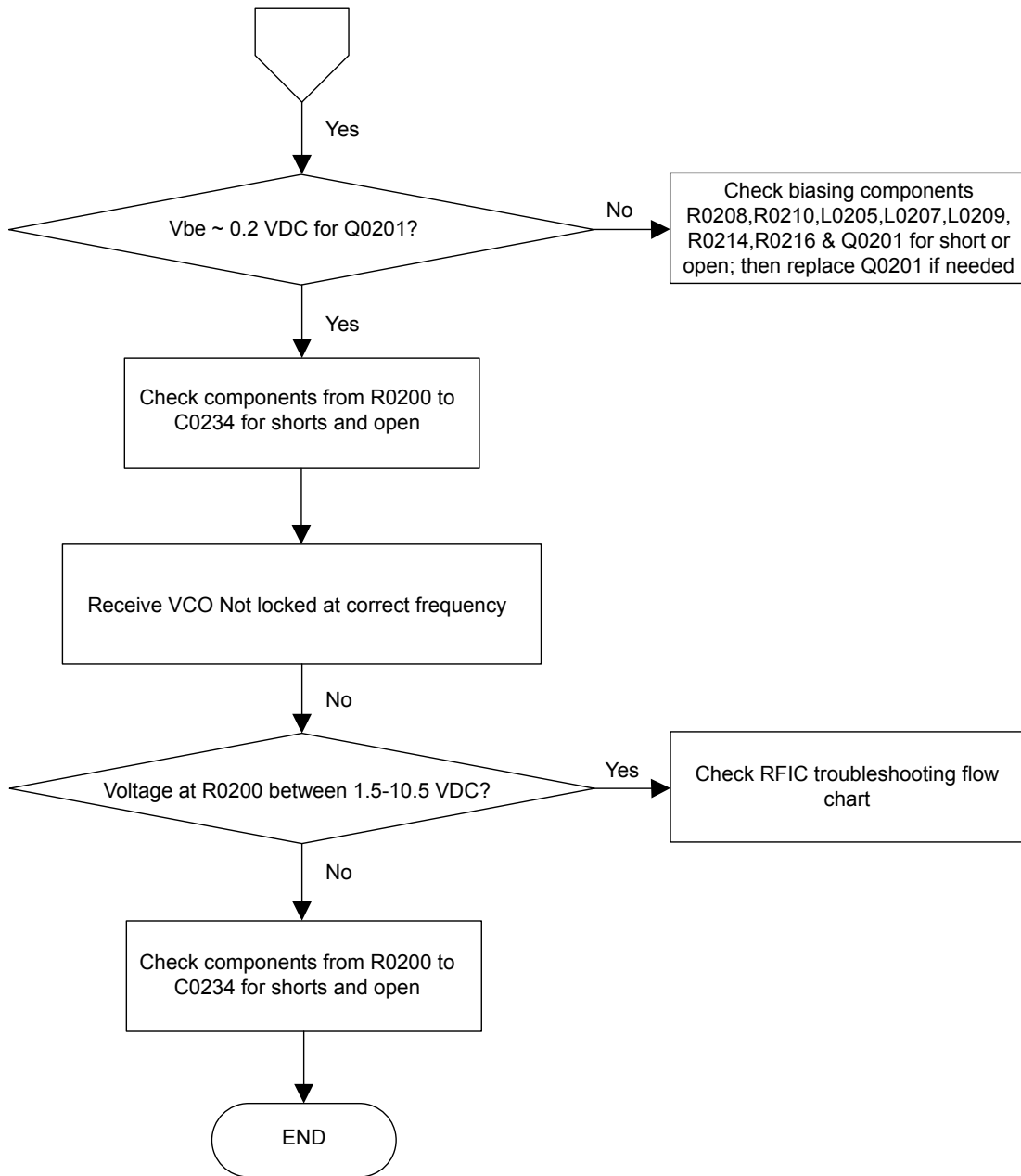

Figure 72: Troubleshooting Flow Chart for Rx VCO (Sheet 2 of 2)



UHF1 Low and High Power Service Information

Figure 73: Troubleshooting Flow Chart for Rx VCO (Sheet 1 of 3)

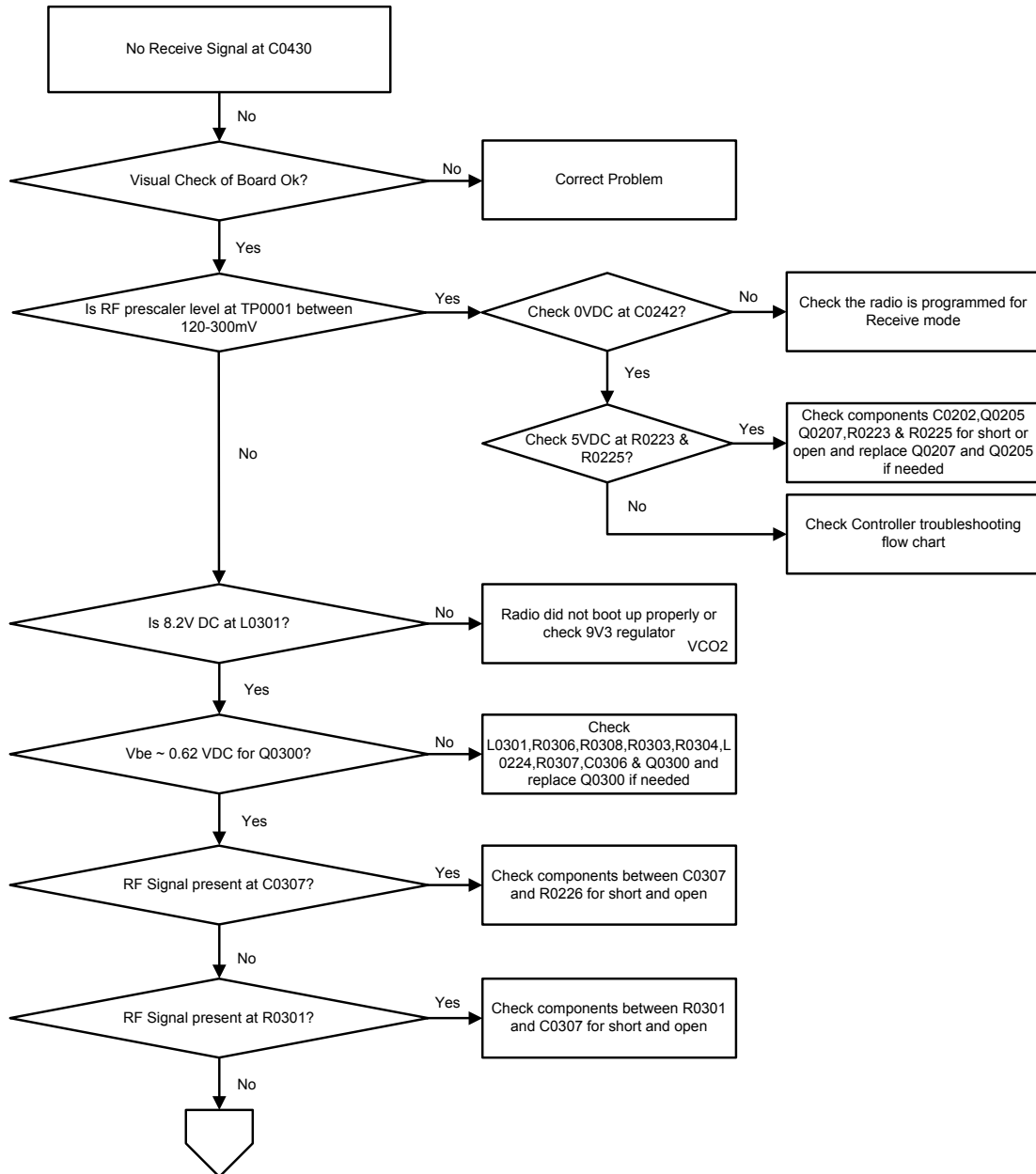

Figure 74: Troubleshooting Flow Chart for Rx VCO (Sheet 2 of 3)

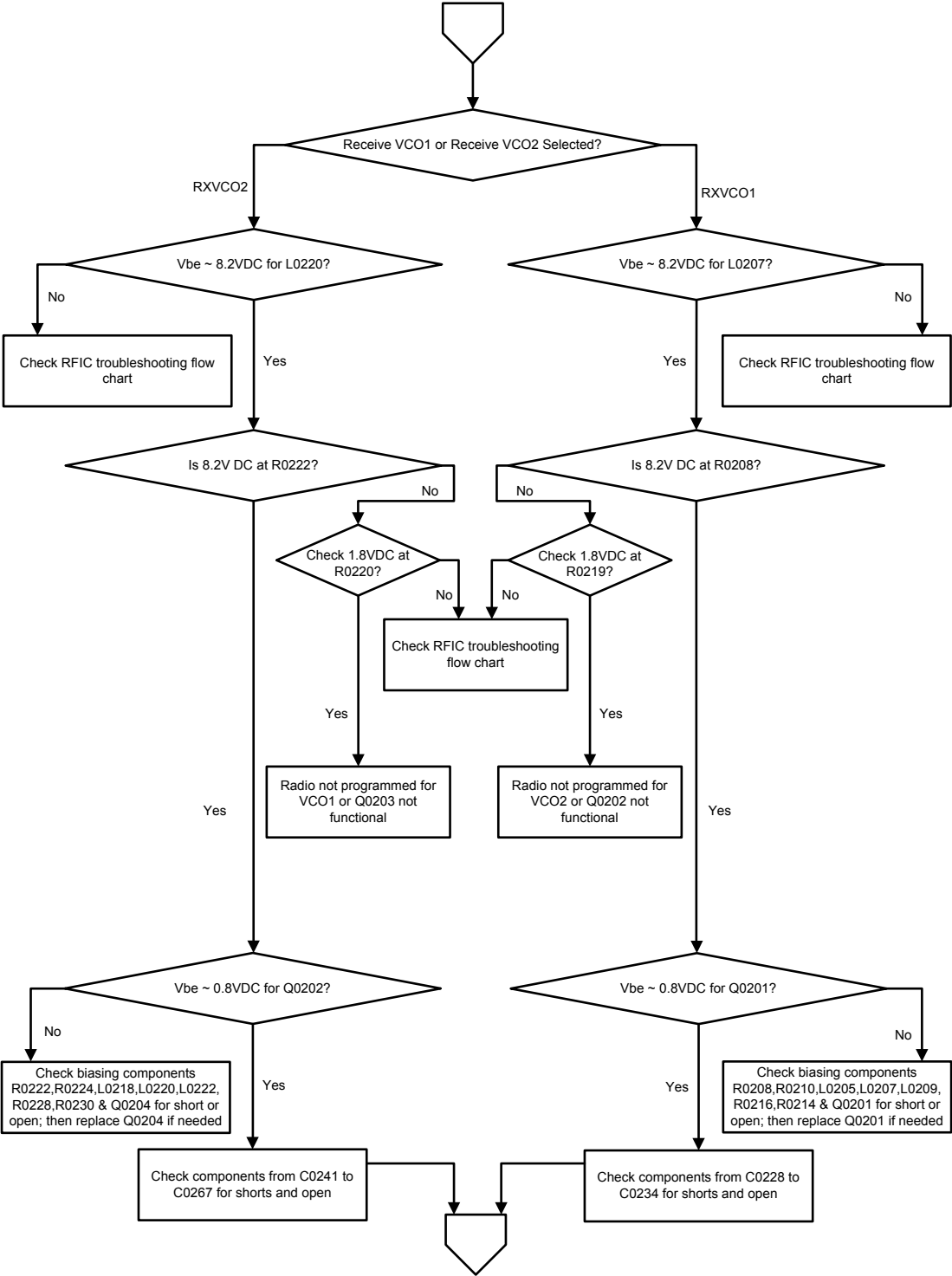
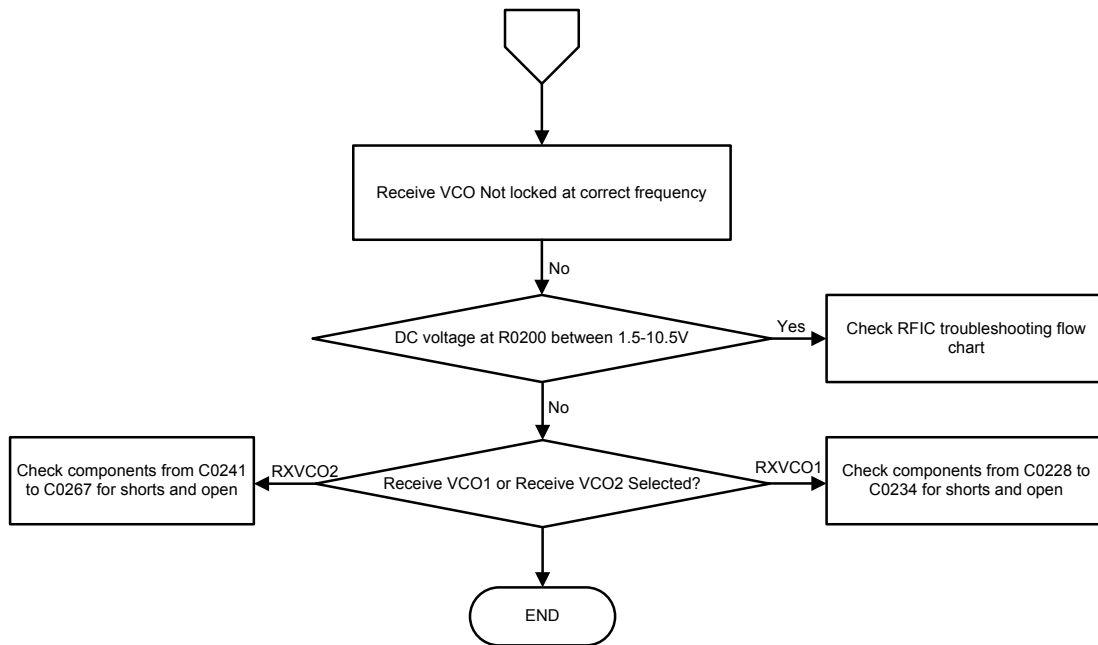

Figure 75: Troubleshooting Flow Chart for Rx VCO (Sheet 3 of 3)



UHF2 Service Information

Figure 76: Troubleshooting Flow Chart for Rx VCO (Sheet 1 of 3)

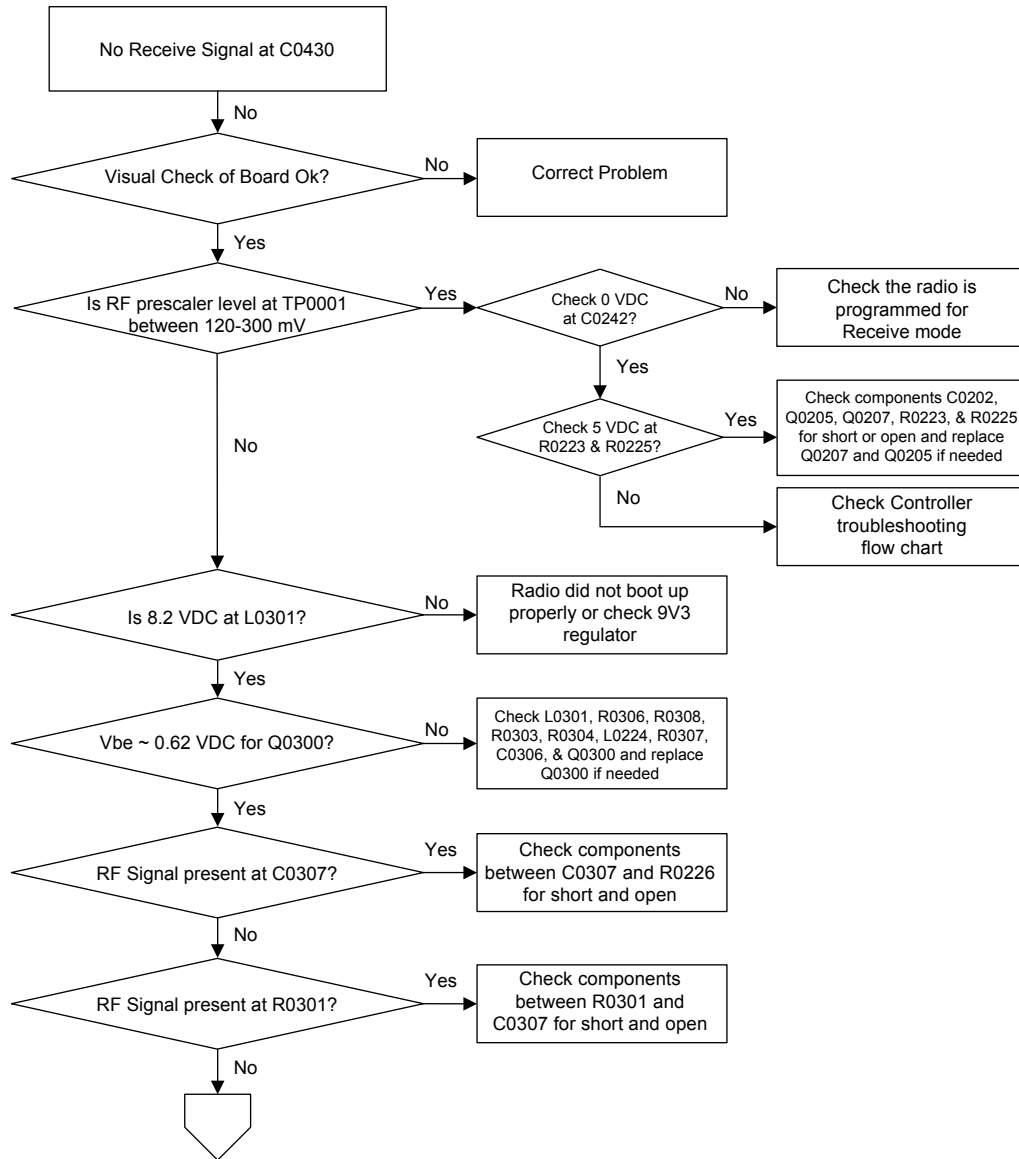

Figure 77: Troubleshooting Flow Chart for Rx VCO (Sheet 2 of 3)

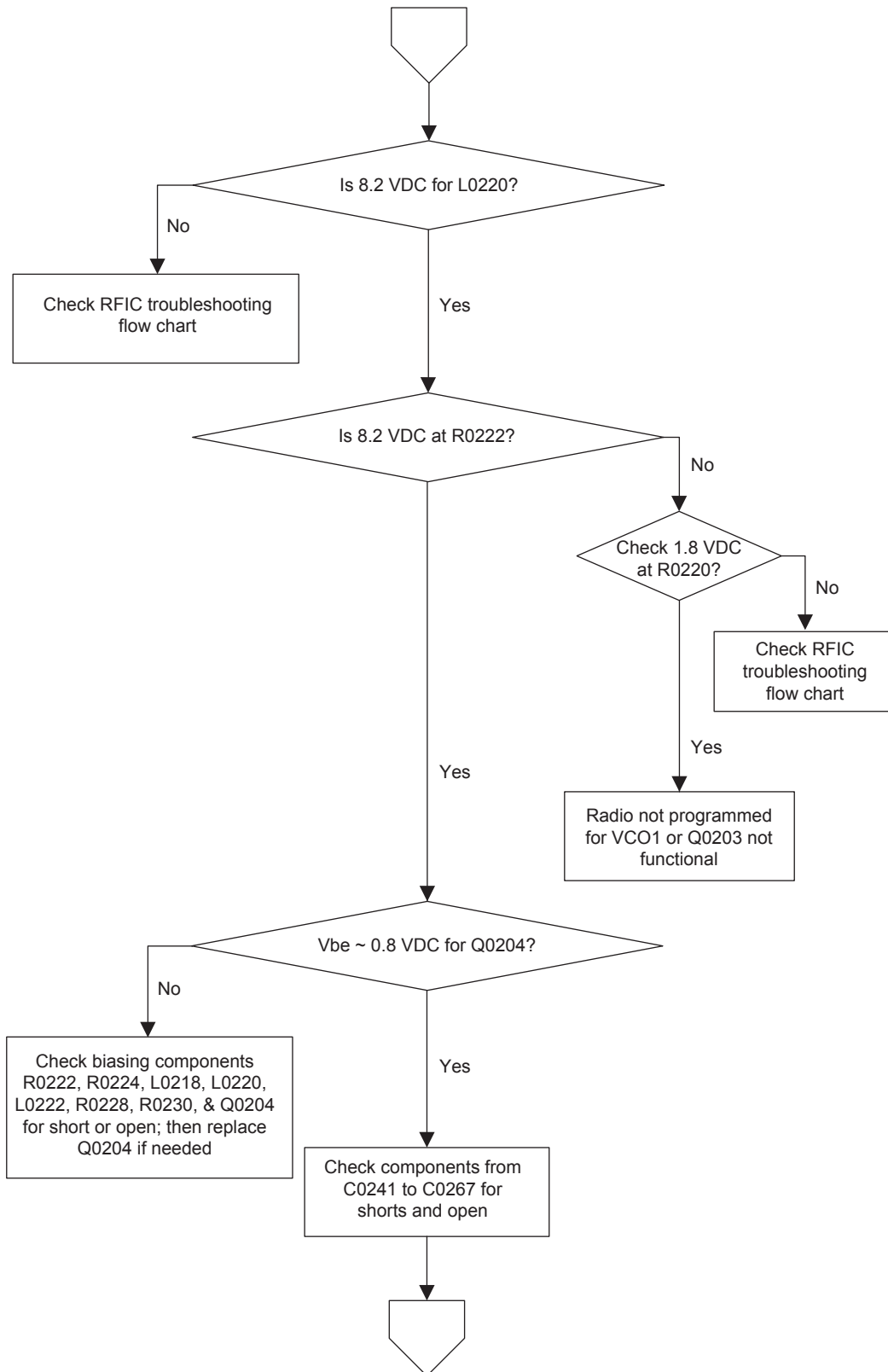
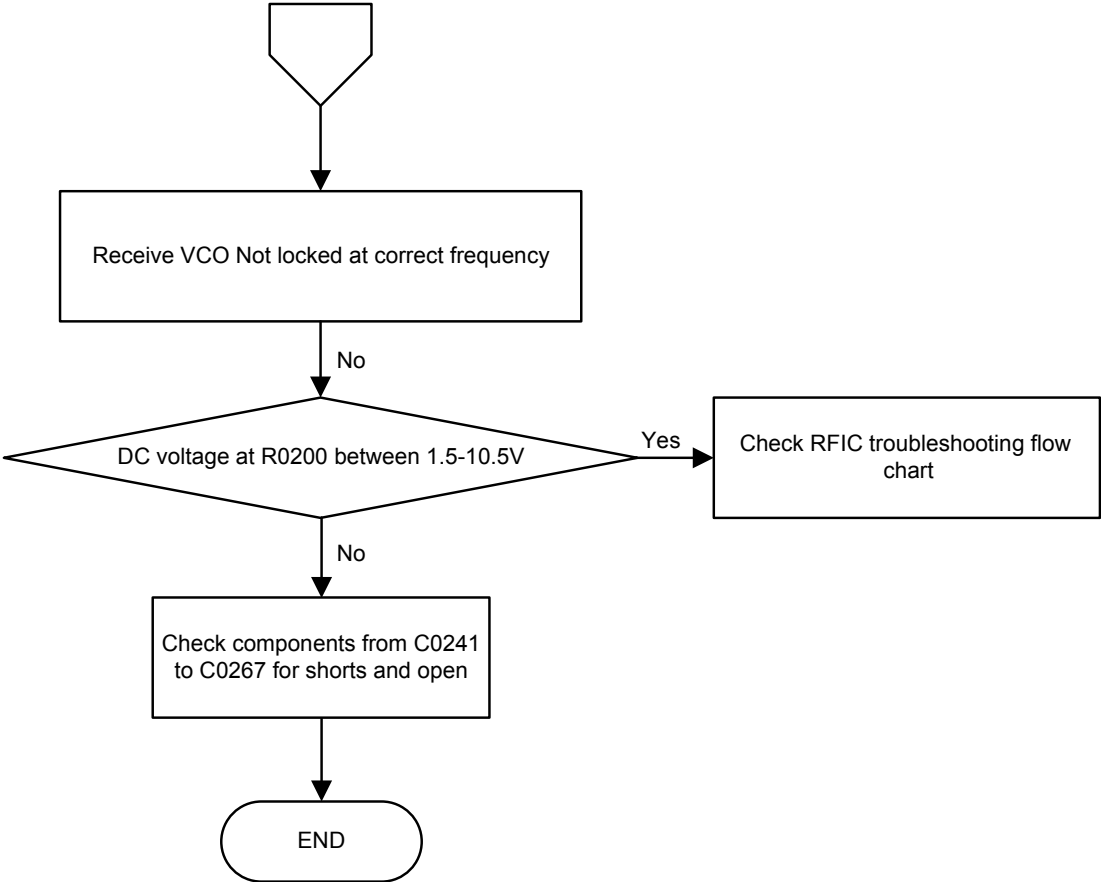

Figure 78: Troubleshooting Flow Chart for Rx VCO (Sheet 3 of 3)



800/900 Band Service Information

Figure 79: Troubleshooting Flow Chart for Rx VCO (Sheet 1 of 3)

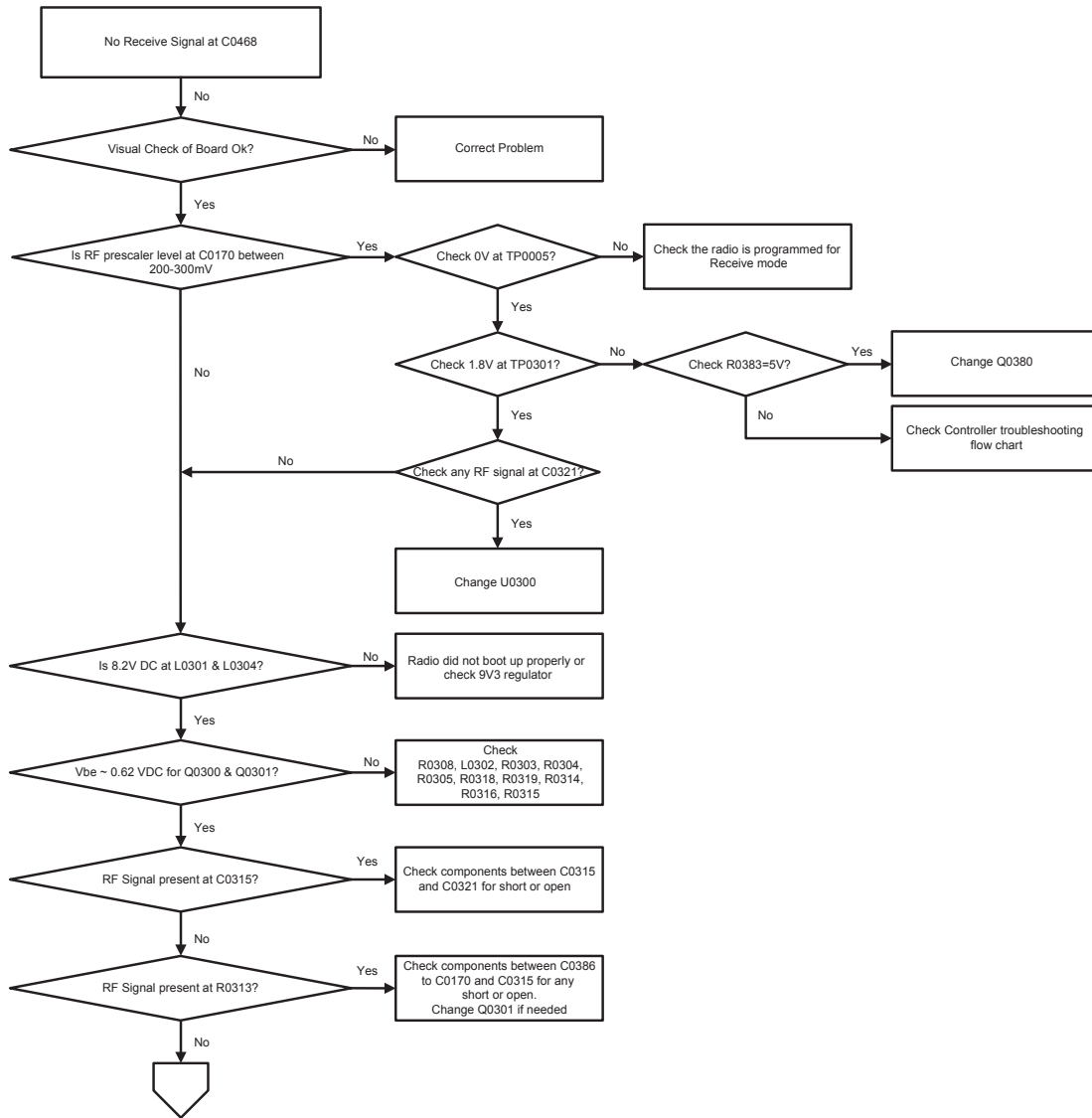

Figure 80: Troubleshooting Flow Chart for Rx VCO (Sheet 2 of 3)

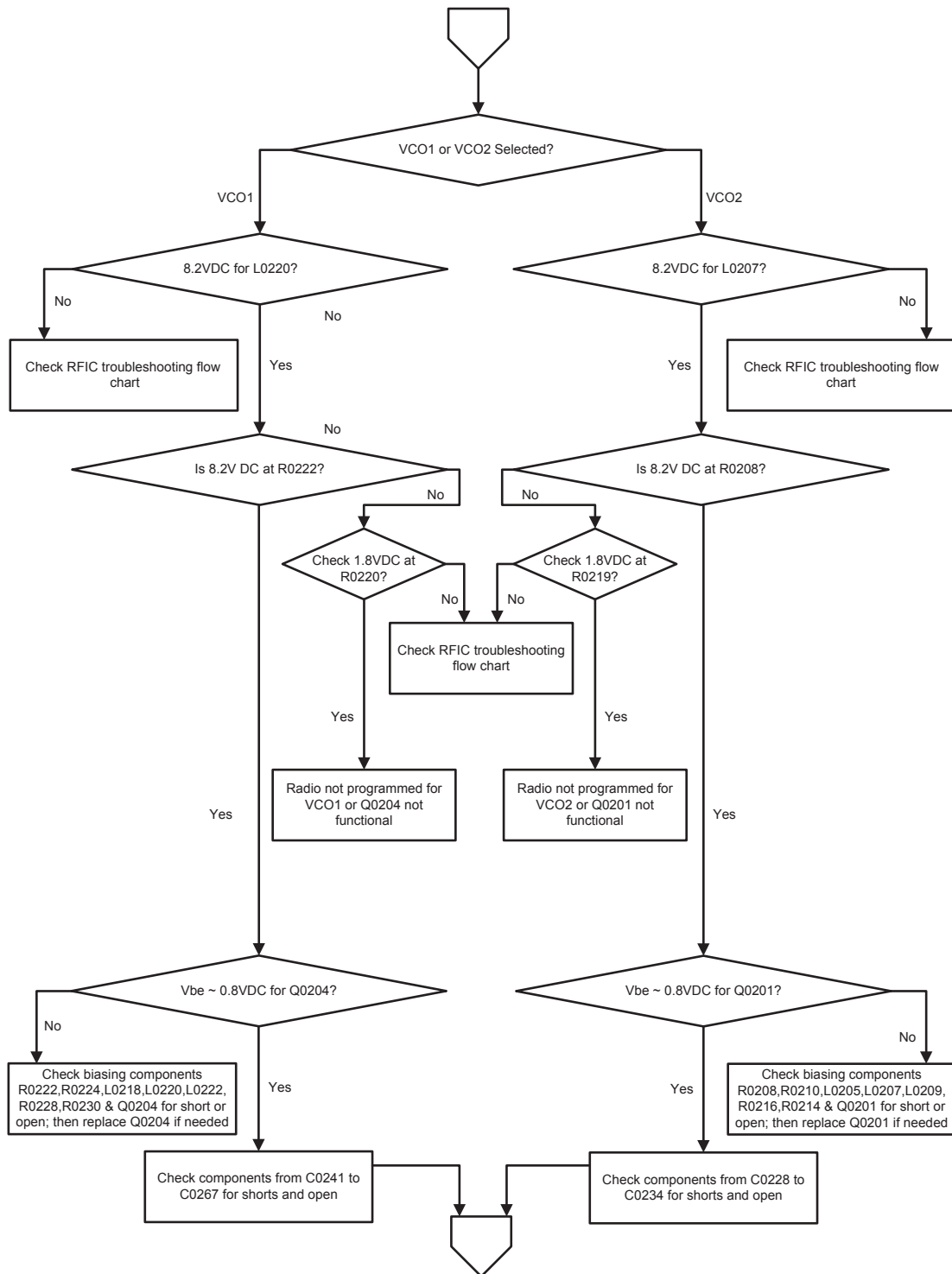
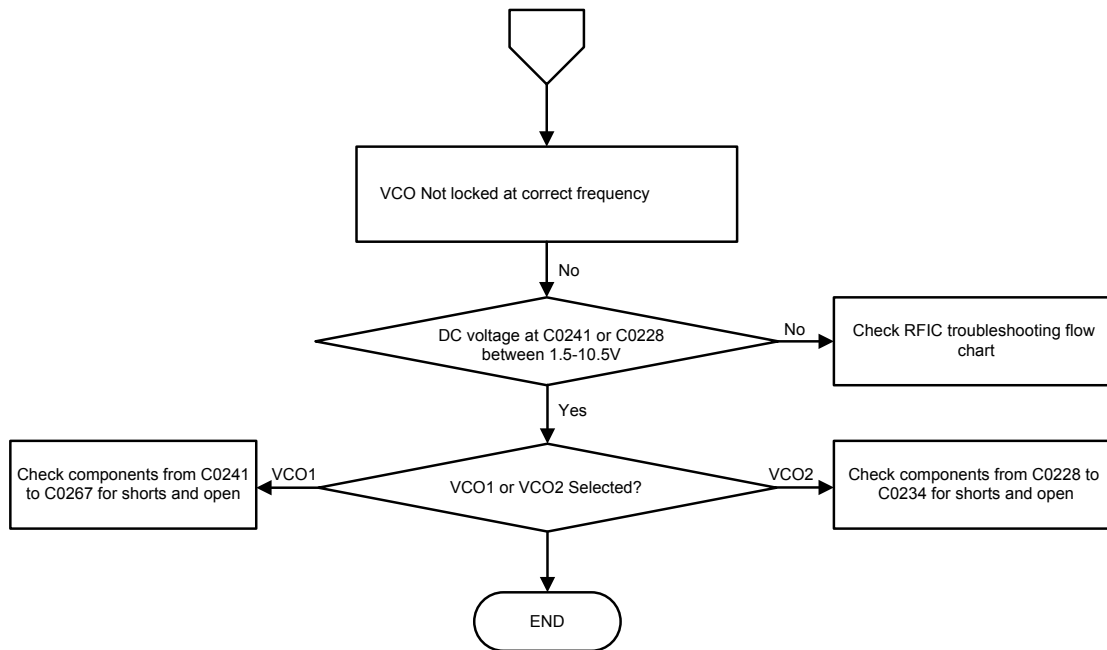

Figure 81: Troubleshooting Flow Chart for Rx VCO (Sheet 3 of 3)



7.3.5 Troubleshooting Flow Chart for Tx VCO

VHF Low and High Power Service Information

Figure 82: Troubleshooting Flow Chart for Tx VCO (Sheet 1 of 2)

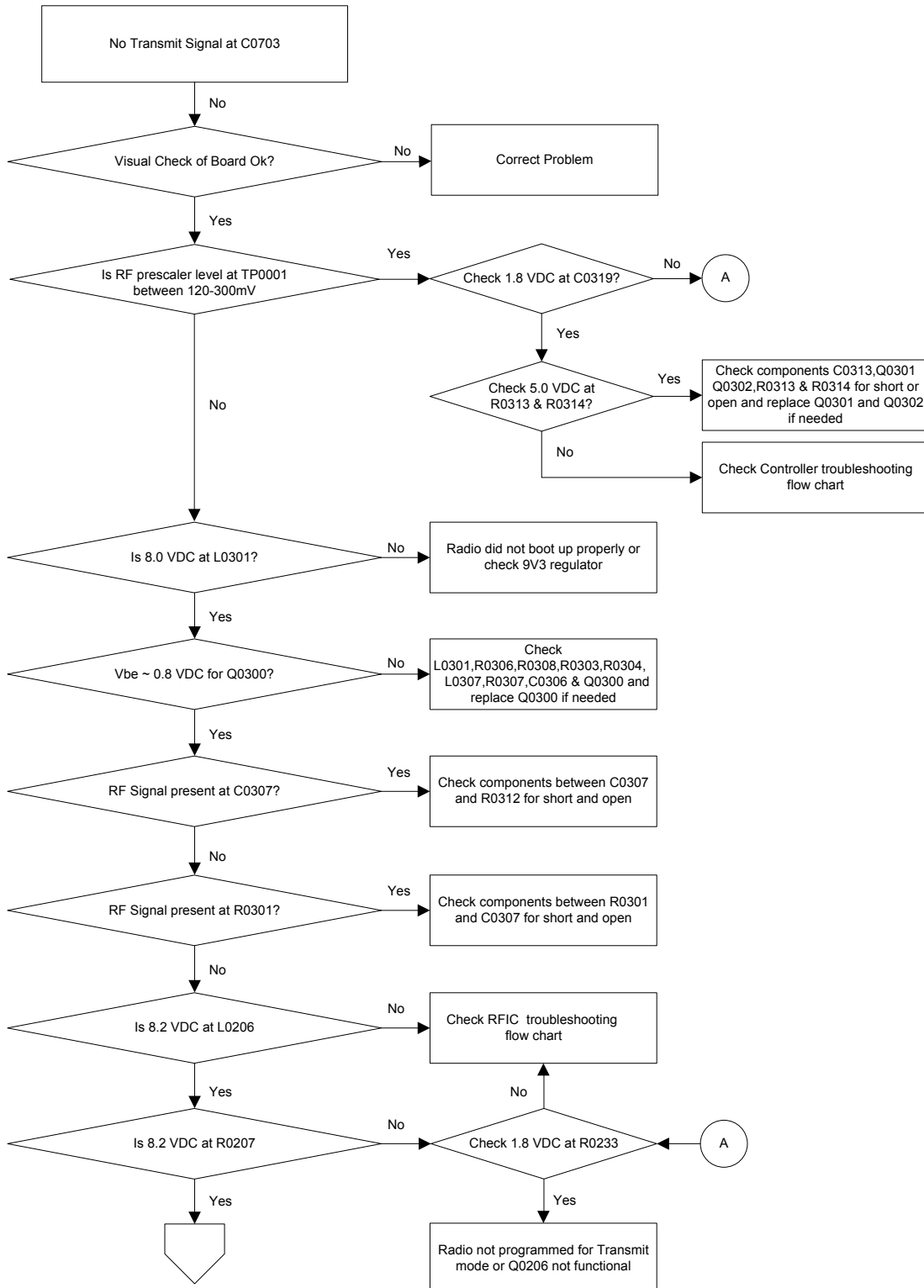
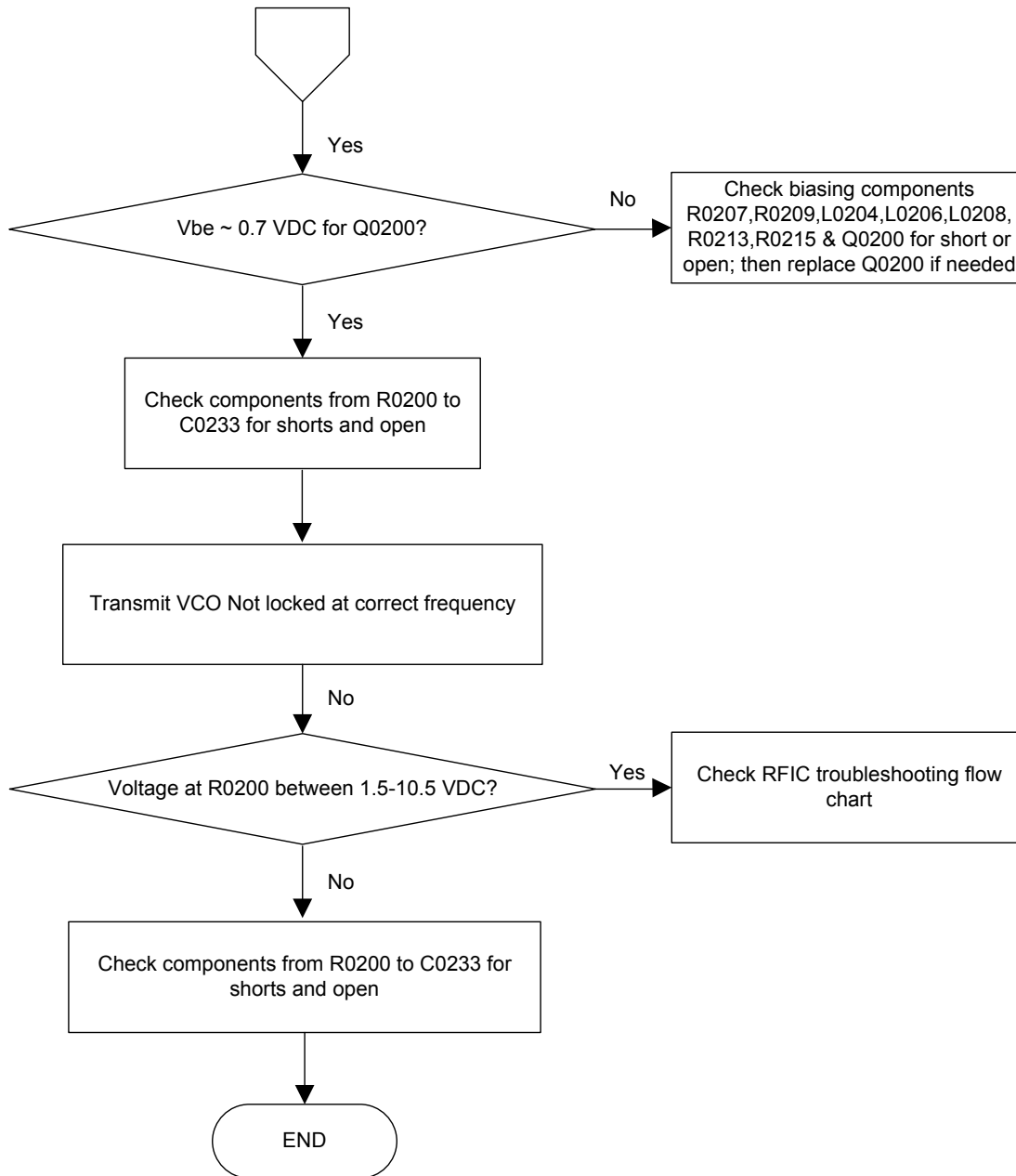

Figure 83: Troubleshooting Flow Chart for Tx VCO (Sheet 2 of 2)



UHF1 Low and High Power Service Information

Figure 84: Troubleshooting Flow Chart for Tx VCO (Sheet 1 of 2)

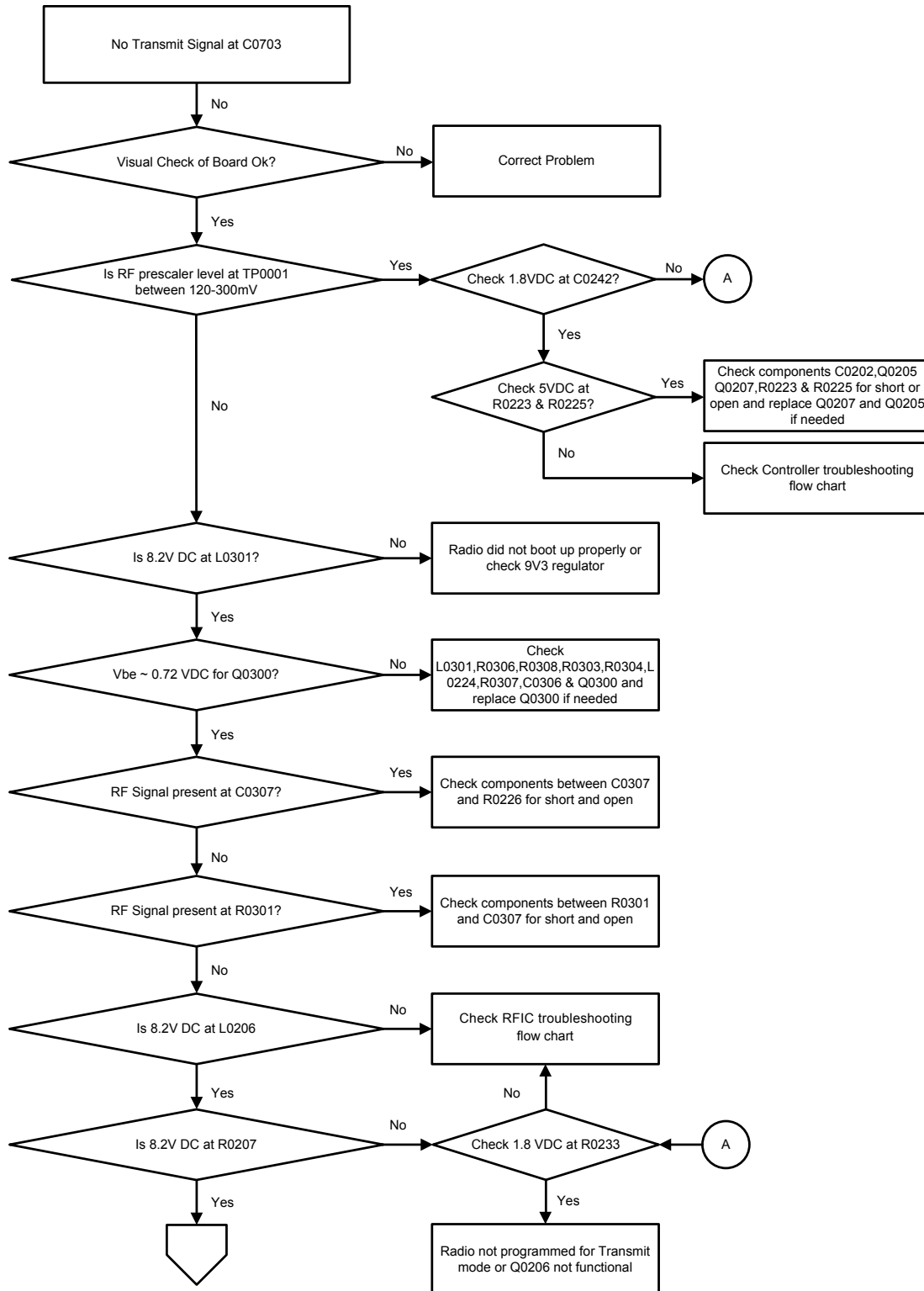
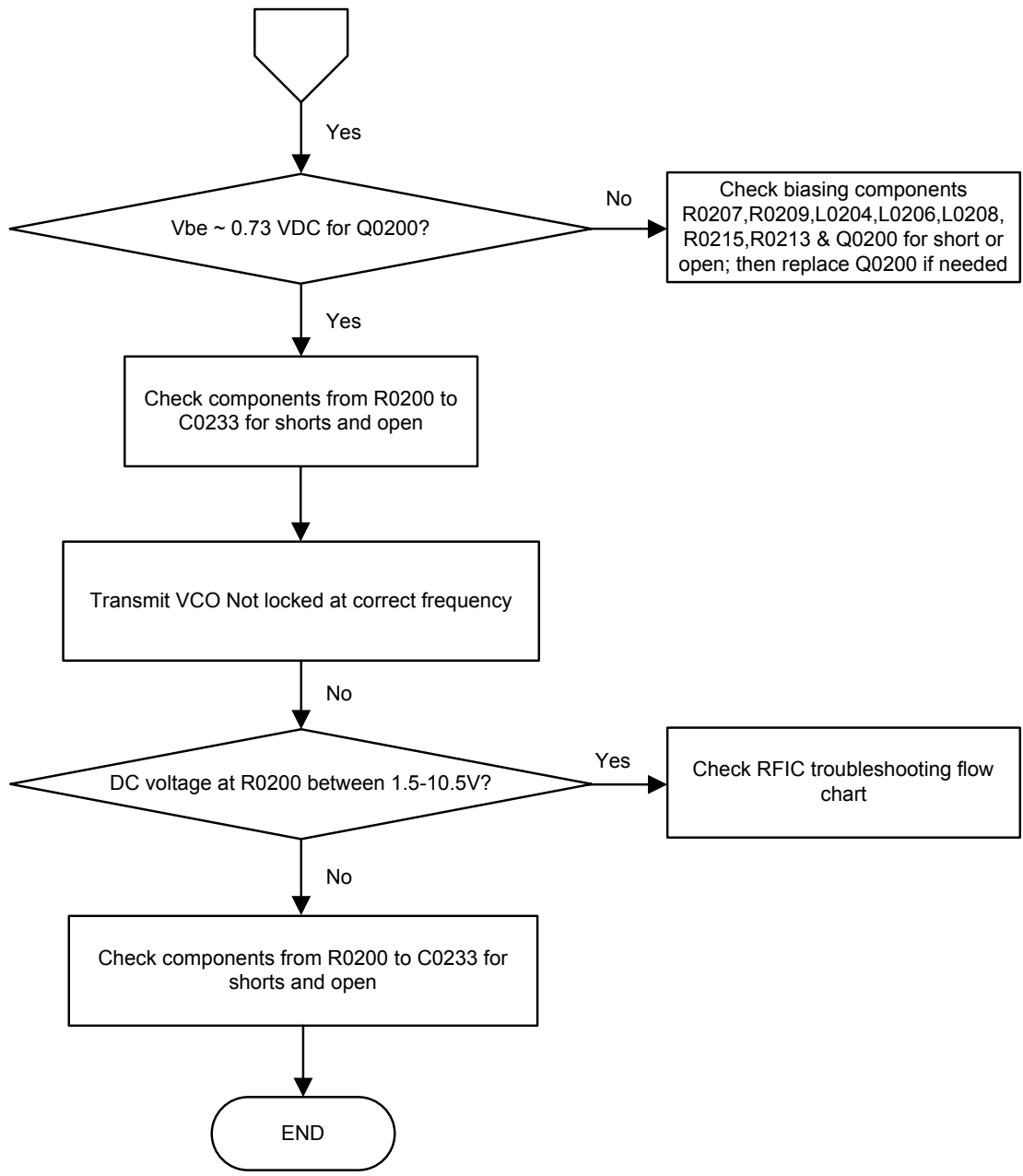

Figure 85: Troubleshooting Flow Chart for Tx VCO (Sheet 2 of 2)



UHF2 Service Information

Figure 86: Troubleshooting Flow Chart for Tx VCO (Sheet 1 of 2)

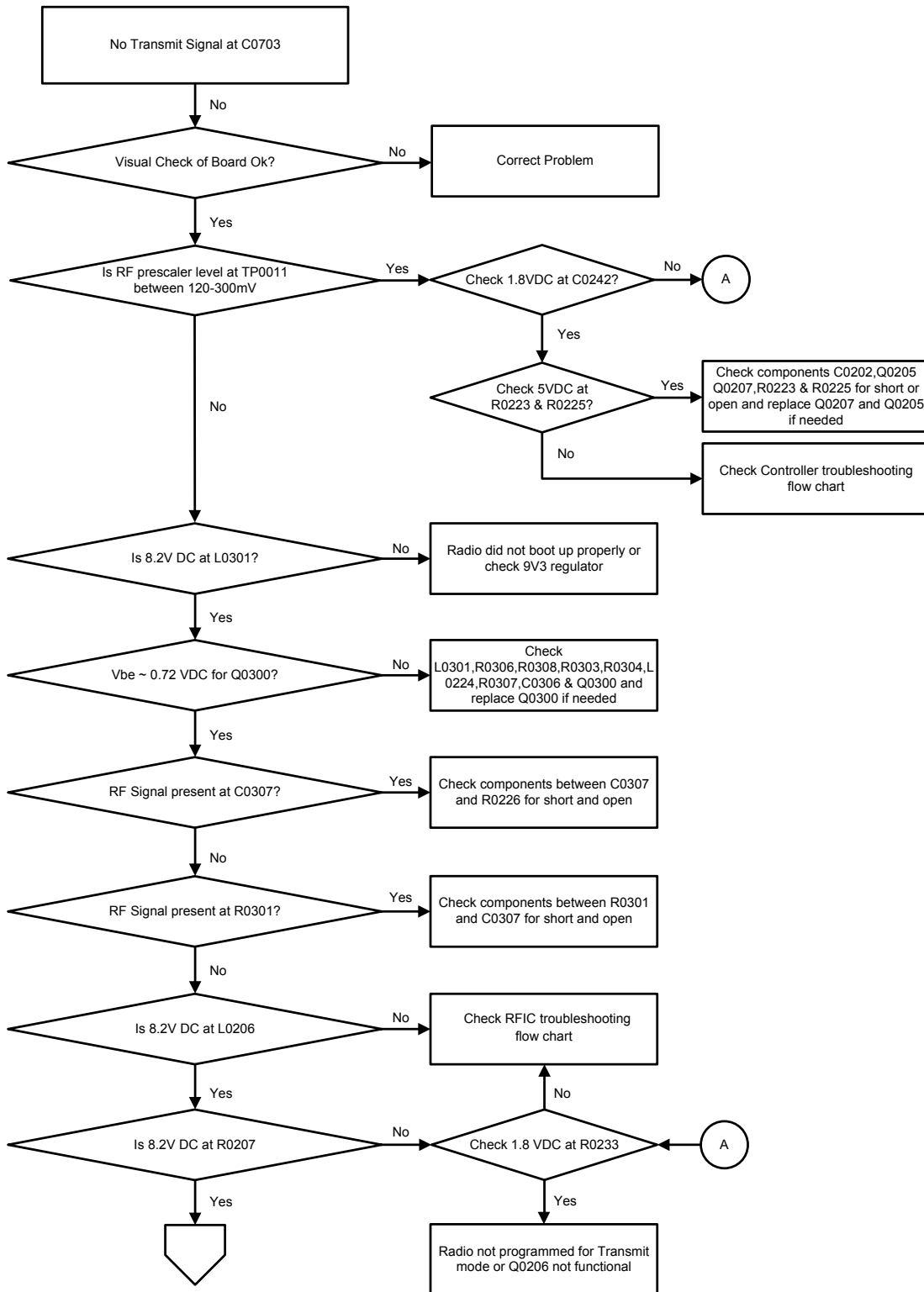
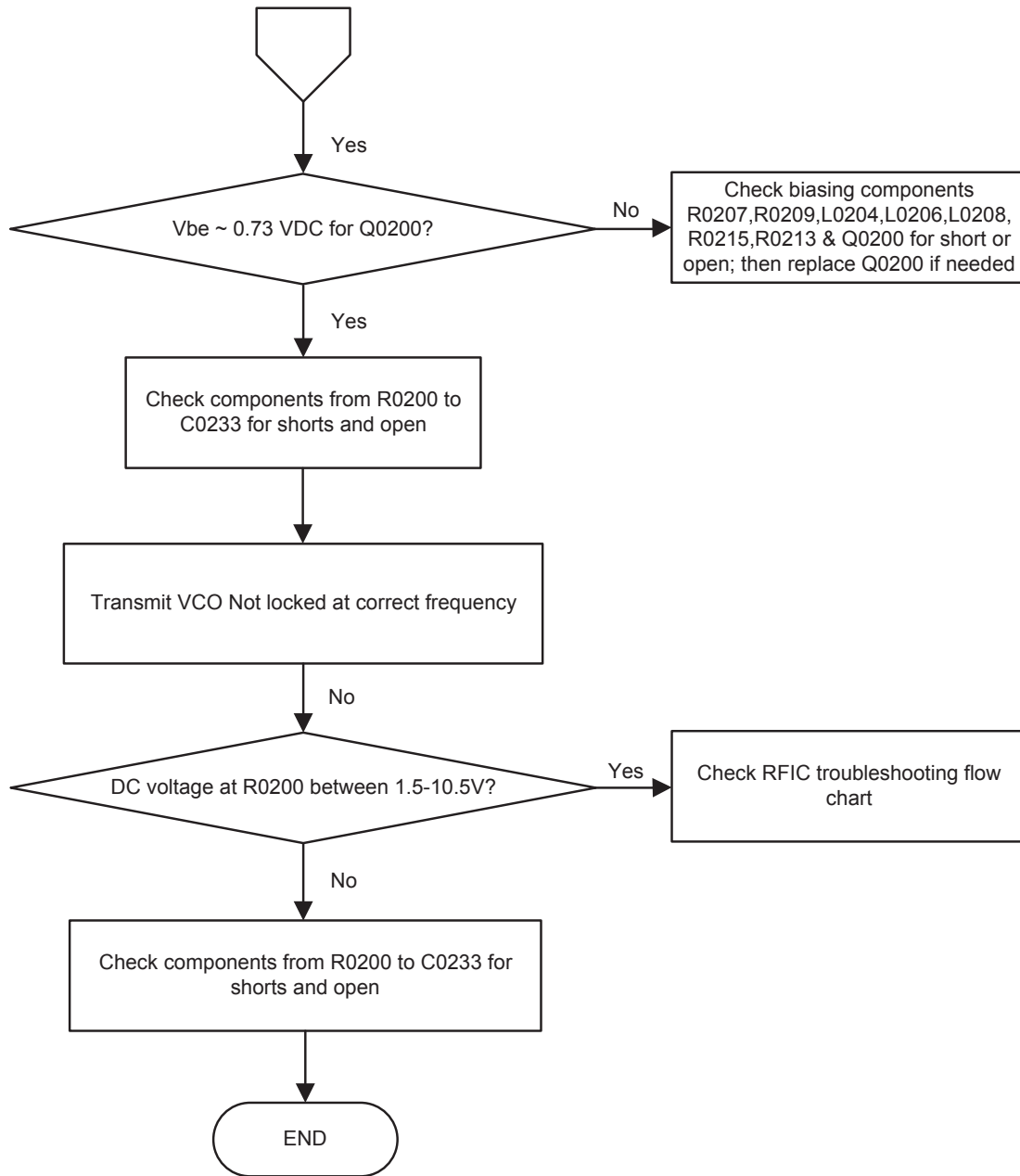

Figure 87: Troubleshooting Flow Chart for Tx VCO (Sheet 2 of 2)



800/900 Band Service Information

Figure 88: Troubleshooting Flow Chart for Tx VCO (Sheet 1 of 3)

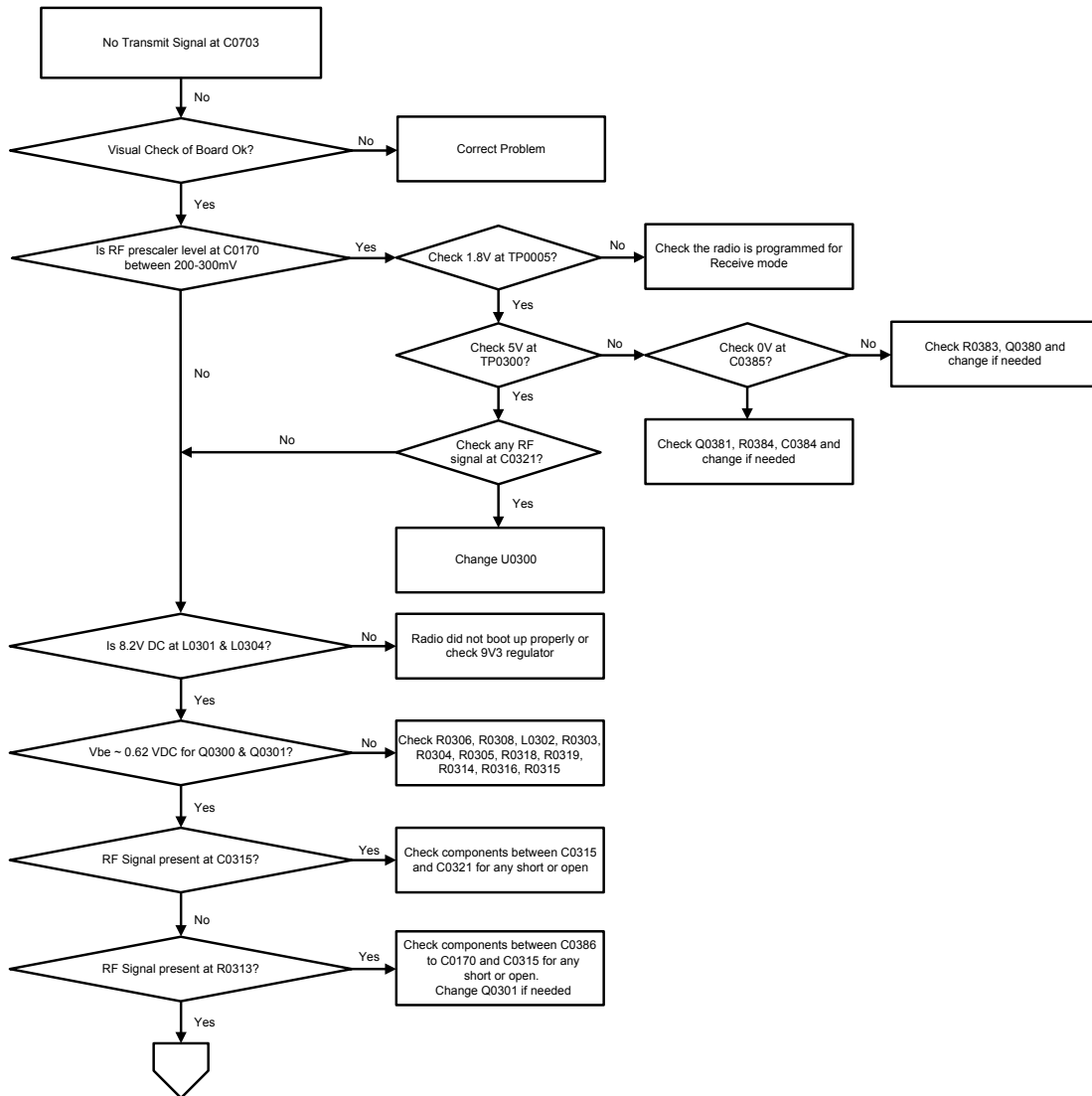

Figure 89: Troubleshooting Flow Chart for Tx VCO (Sheet 2 of 3)

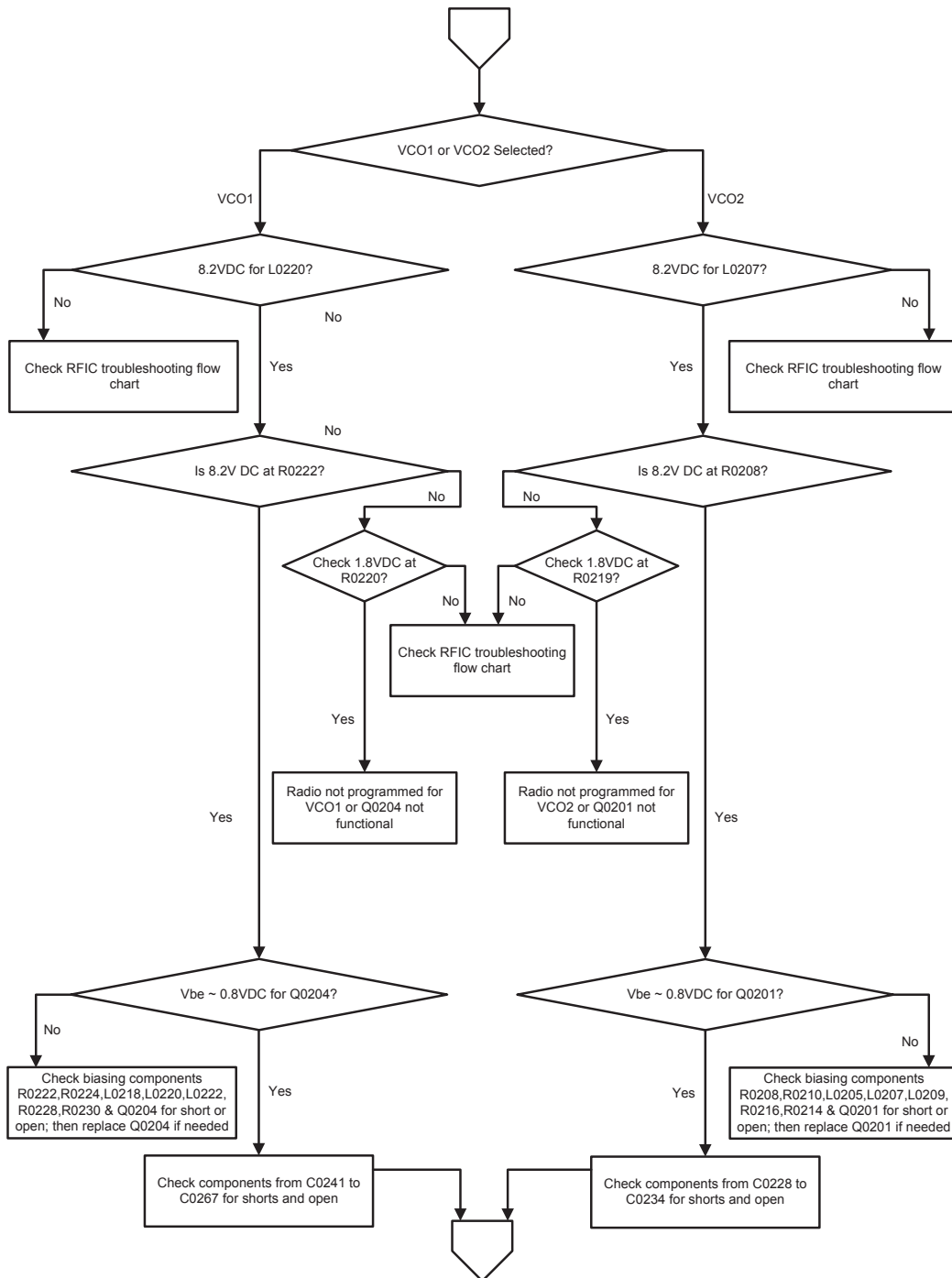
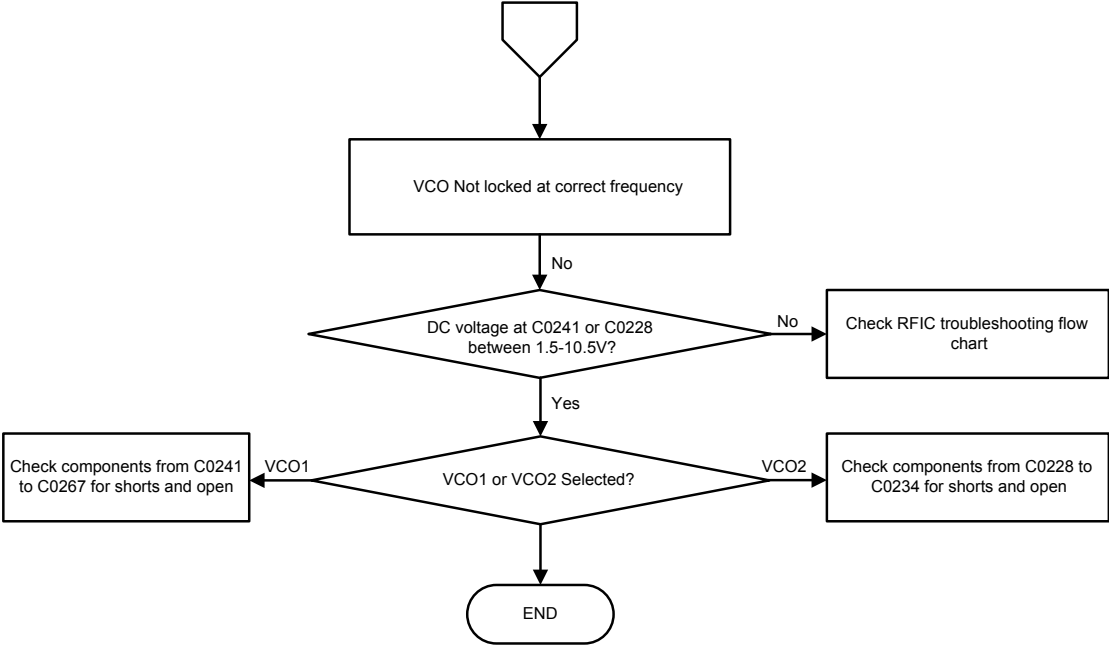

Figure 90: Troubleshooting Flow Chart for Tx VCO (Sheet 3 of 3)



7.4

Troubleshooting Chart for Bluetooth/GNSS/Wi-Fi (PMLN7252_S)

Troubleshooting Flow Chart for Bluetooth

Figure 91: Troubleshooting Flow Chart for Bluetooth (Sheet 1 of 4)

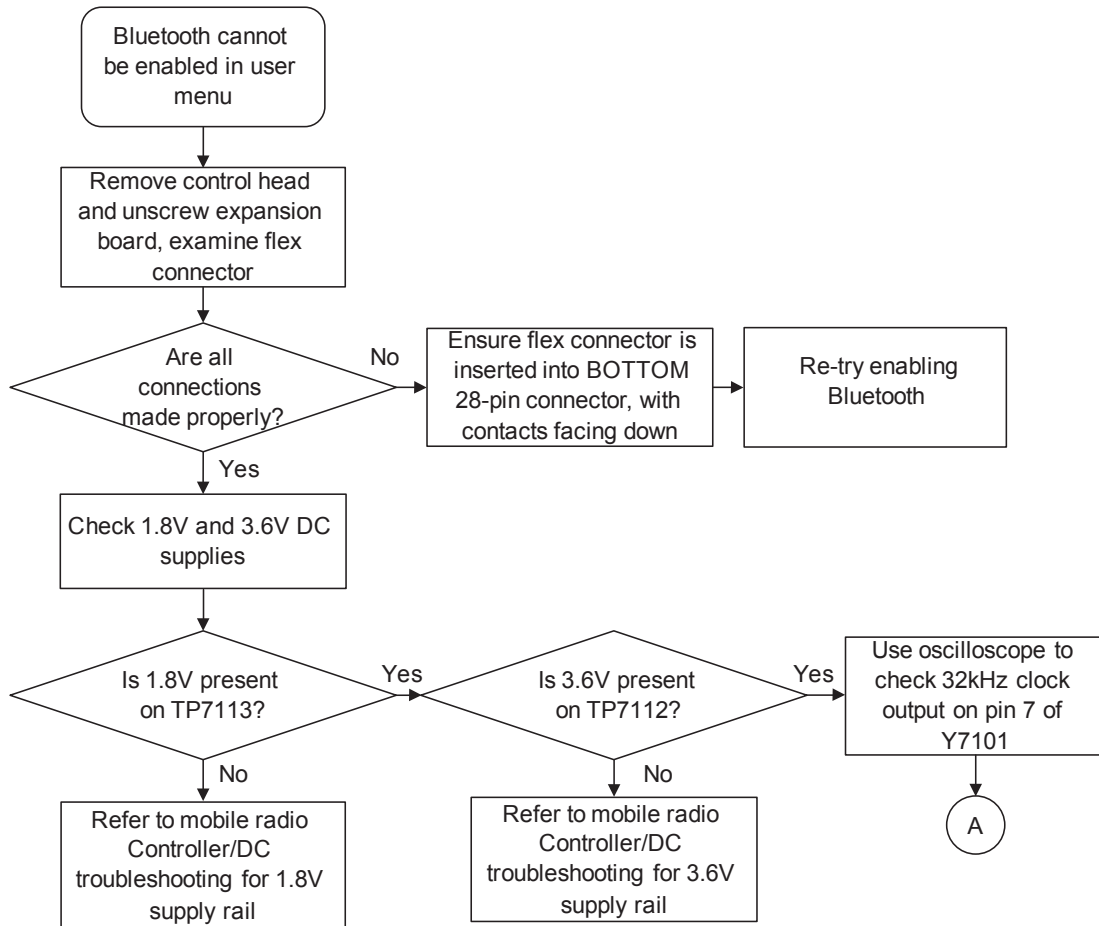

Figure 92: Troubleshooting Flow Chart for Bluetooth (Sheet 2 of 4)

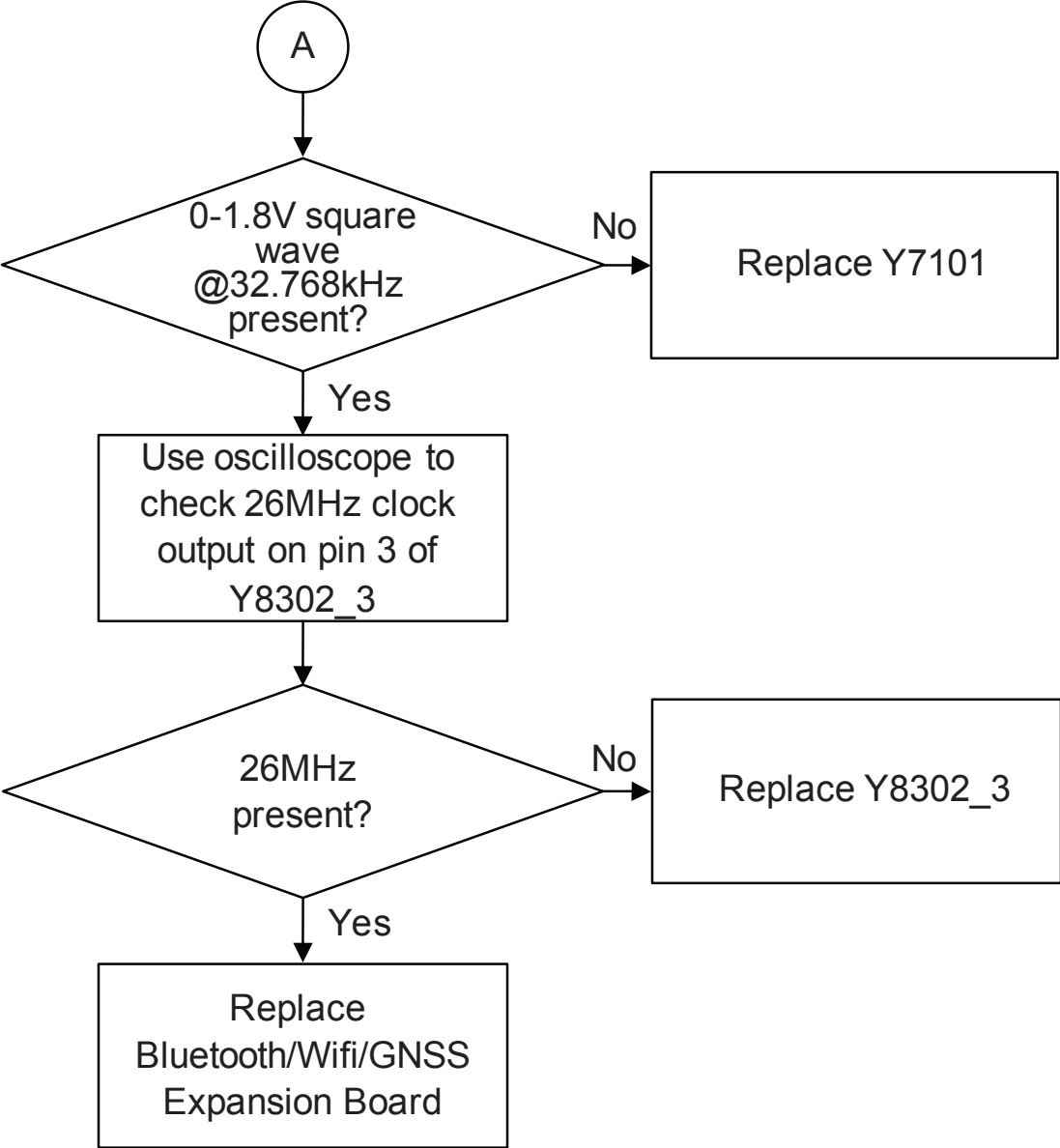

Figure 93: Troubleshooting Flow Chart for Bluetooth (Sheet 3 of 4)

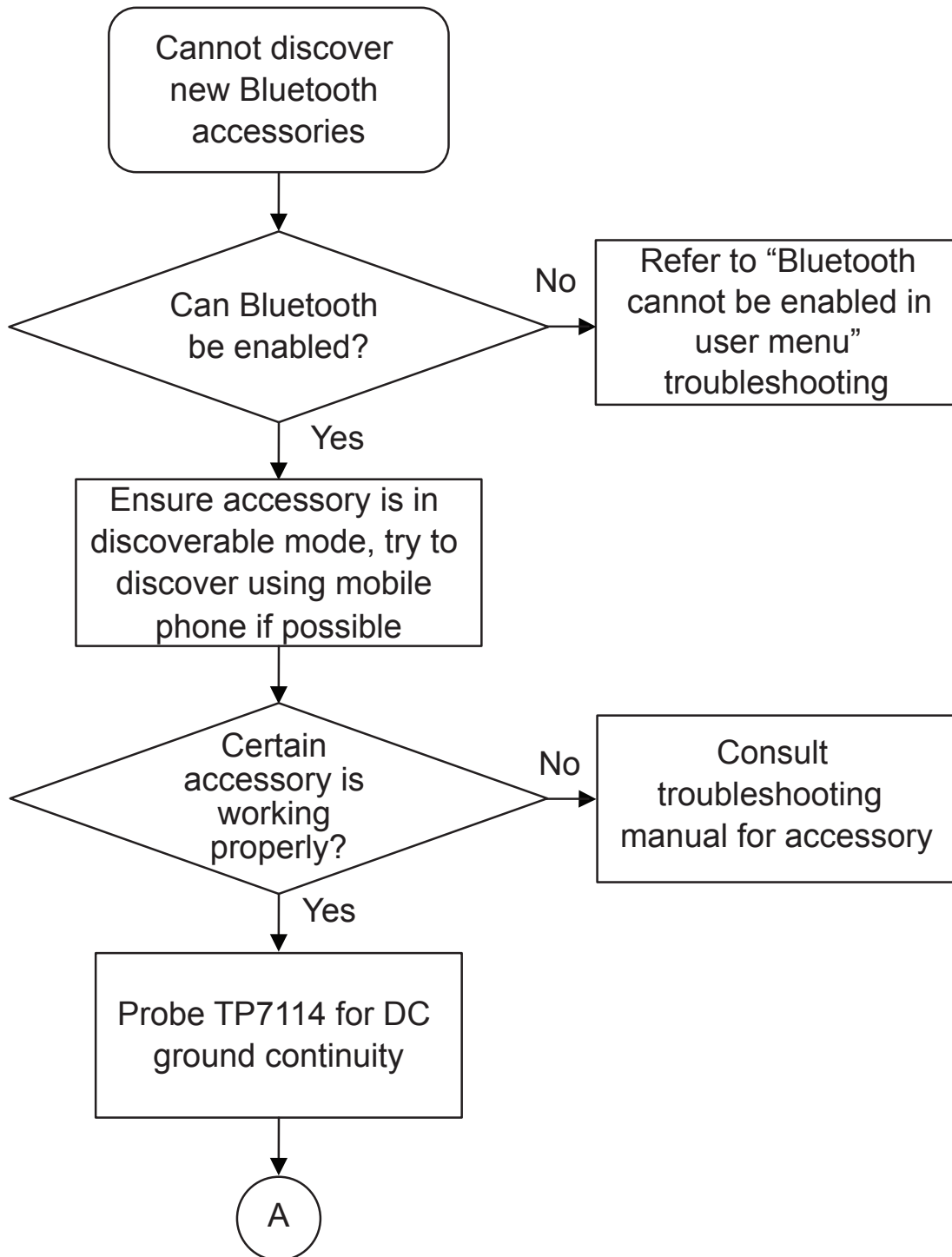
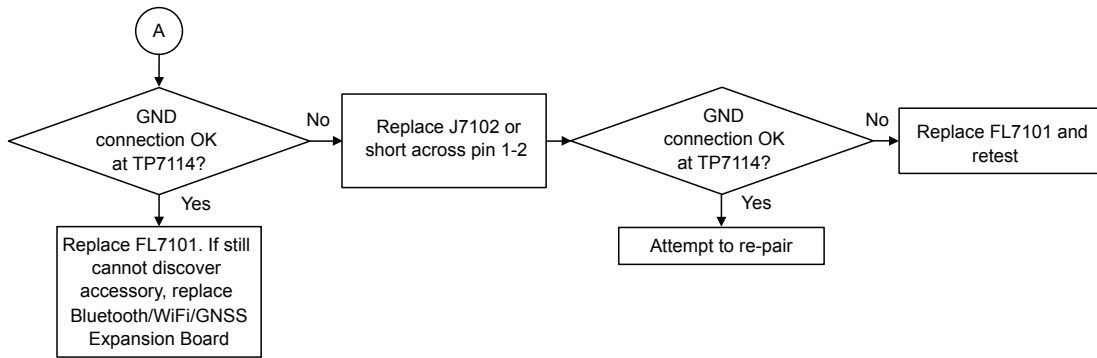

Figure 94: Troubleshooting Flow Chart for Bluetooth (Sheet 4 of 4)



Troubleshooting Flow Chart for GNSS

Figure 95: Troubleshooting Flow Chart for GNSS (Sheet 1 of 3)

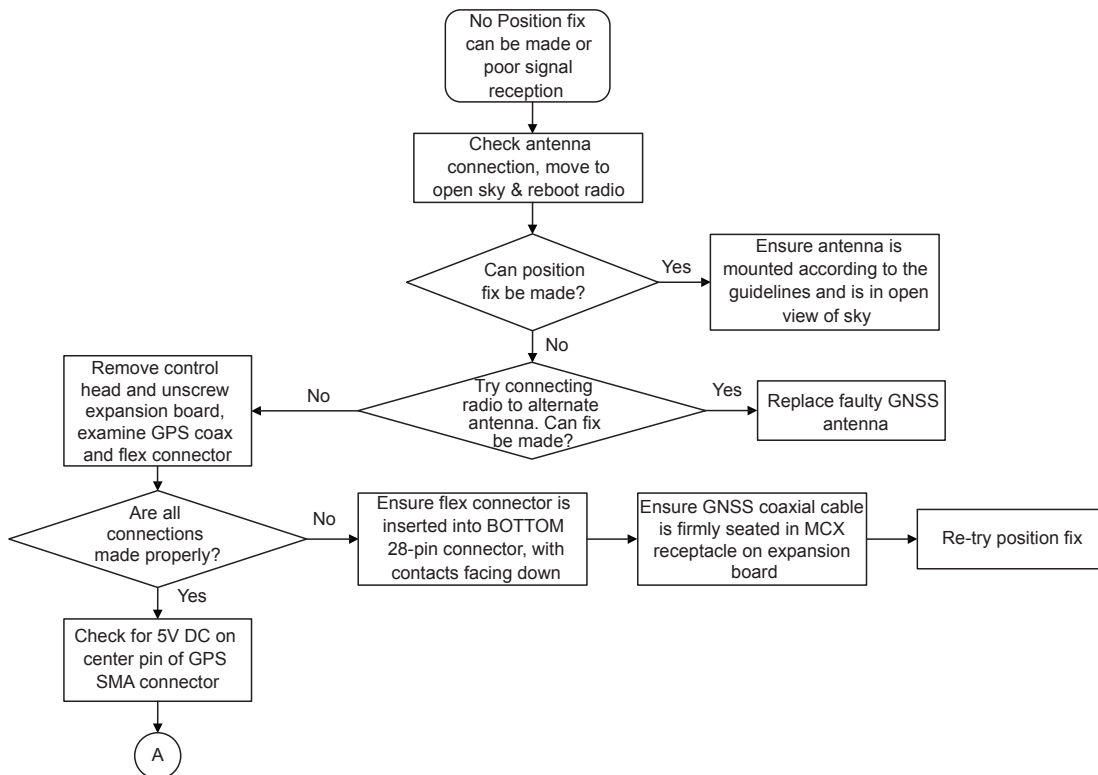

Figure 96: Troubleshooting Flow Chart for GNSS (Sheet 2 of 3)

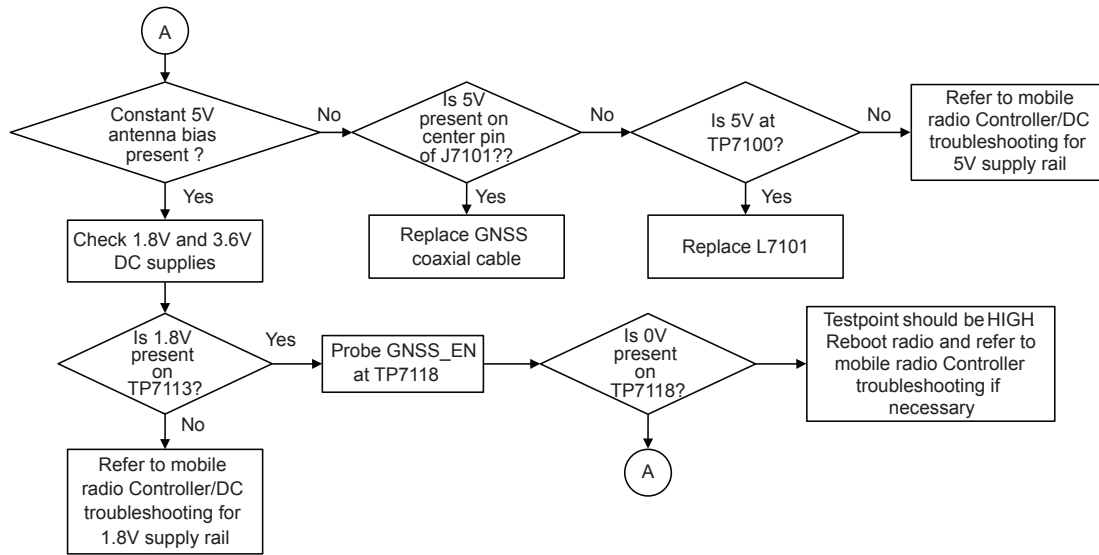
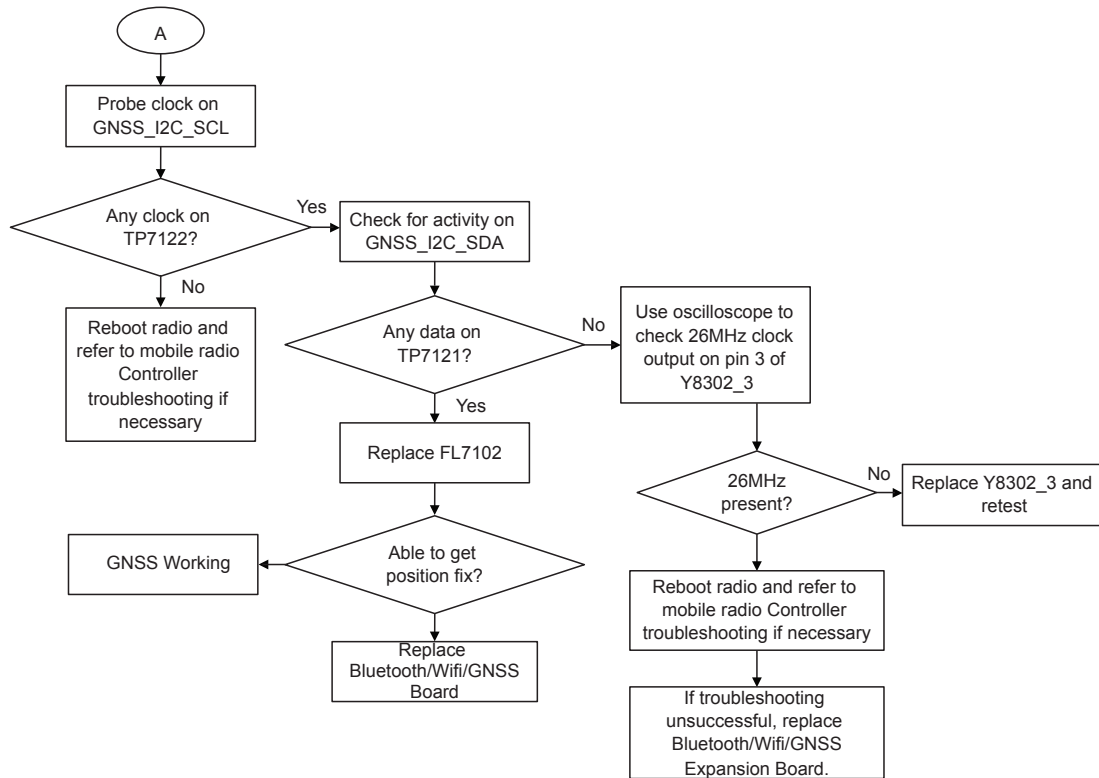

Figure 97: Troubleshooting Flow Chart for GNSS (Sheet 3 of 3)



Troubleshooting Flow Chart for Wi-Fi

Figure 98: Troubleshooting Flow Chart for Wi-Fi (Sheet 1 of 2)

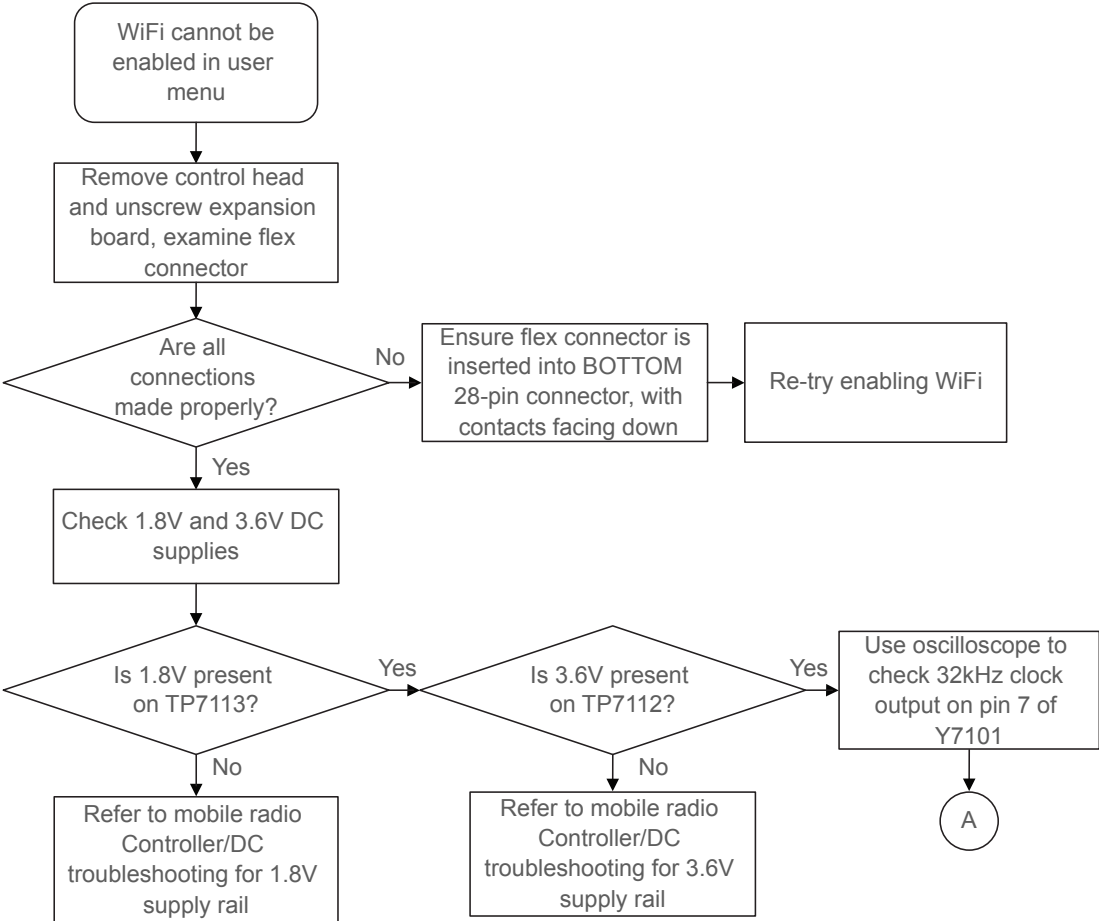
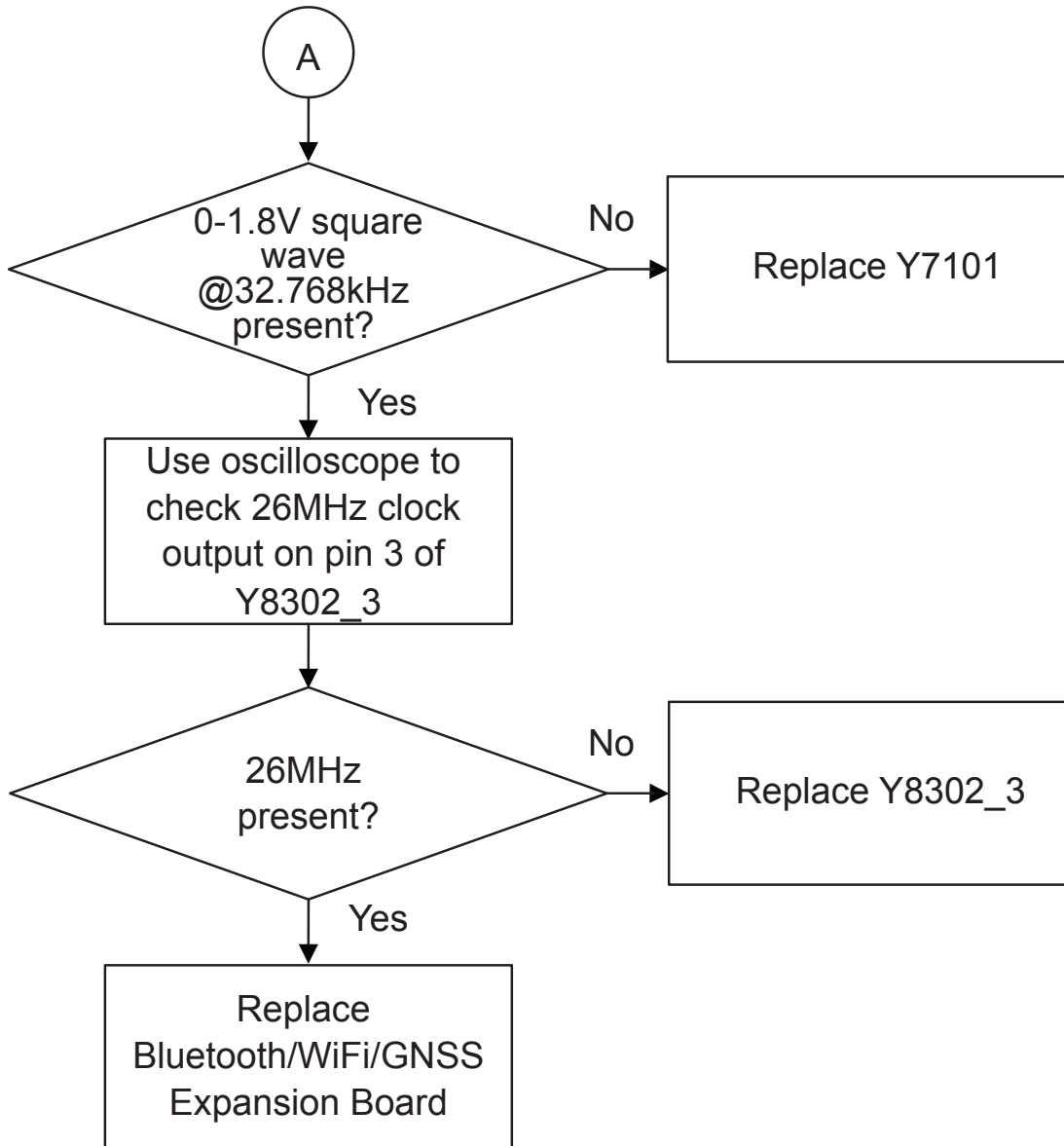
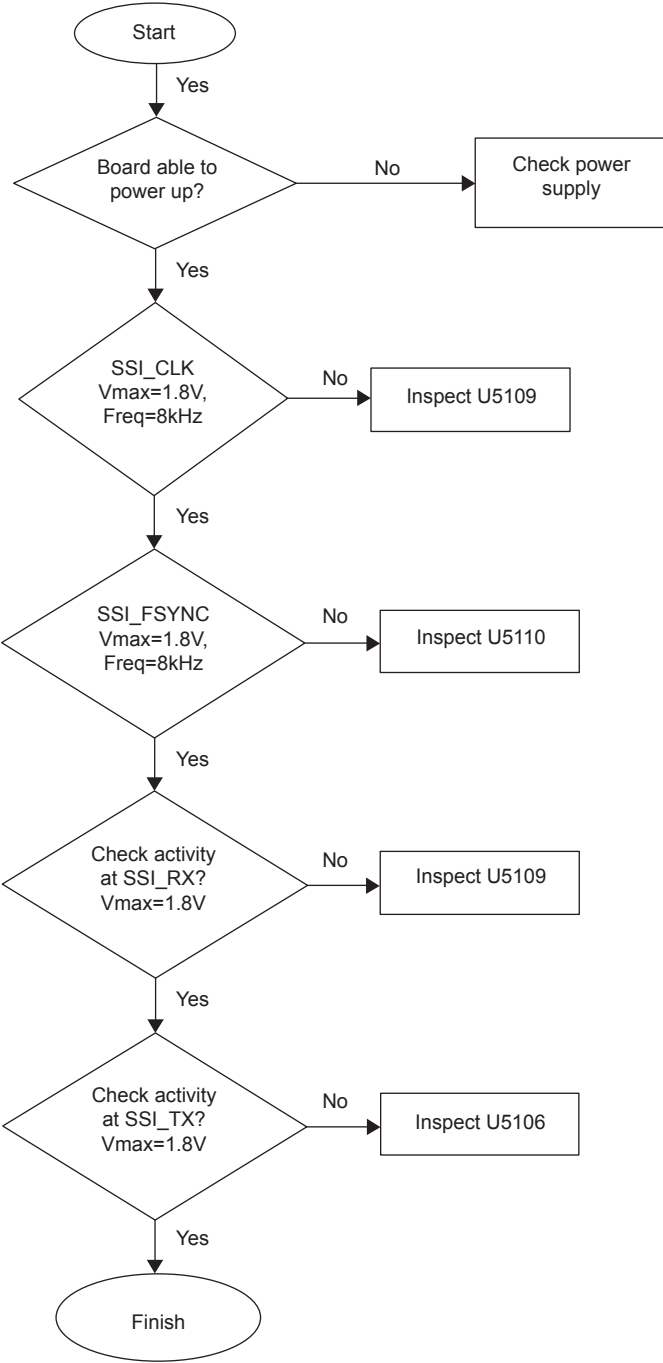

Figure 99: Troubleshooting Flow Chart for Wi-Fi (Sheet 2 of 2)



7.5 Troubleshooting Chart for Generic Option Board (GOB)

Figure 100: Troubleshooting Flow Chart for GOB (PMLN7324_S)



* To check SSI lines, GOB needs to connect with radio
* All the SSI lines must probe with oscilloscope

Chapter 8

Circuit Board, Schematic Diagrams, and Parts List

8.1

Control Head Service Information

8.1.1

Allocation of Schematics and Circuit Boards

This Chapter shows the Schematics and the Parts Lists for the Control Head circuits.

Numeric Display Control Head Schematic Diagram and Parts List

Diagrams:

- [Figure 101: Numeric Display Control Head Top Side PCB No. 84012212002-B on page 129](#)
- [Figure 102: Numeric Display Control Head Bottom Side PCB No. 84012212002-B on page 130](#)
- [Figure 103: Numeric Display Control Head Schematic Diagram on page 131](#)

[Parts List for Numeric Display Control Head on page 132](#)

8.1.1.1

Numeric Display Control Head Circuit Board and Schematic Diagram

Figure 101: Numeric Display Control Head Top Side PCB No. 84012212002-B

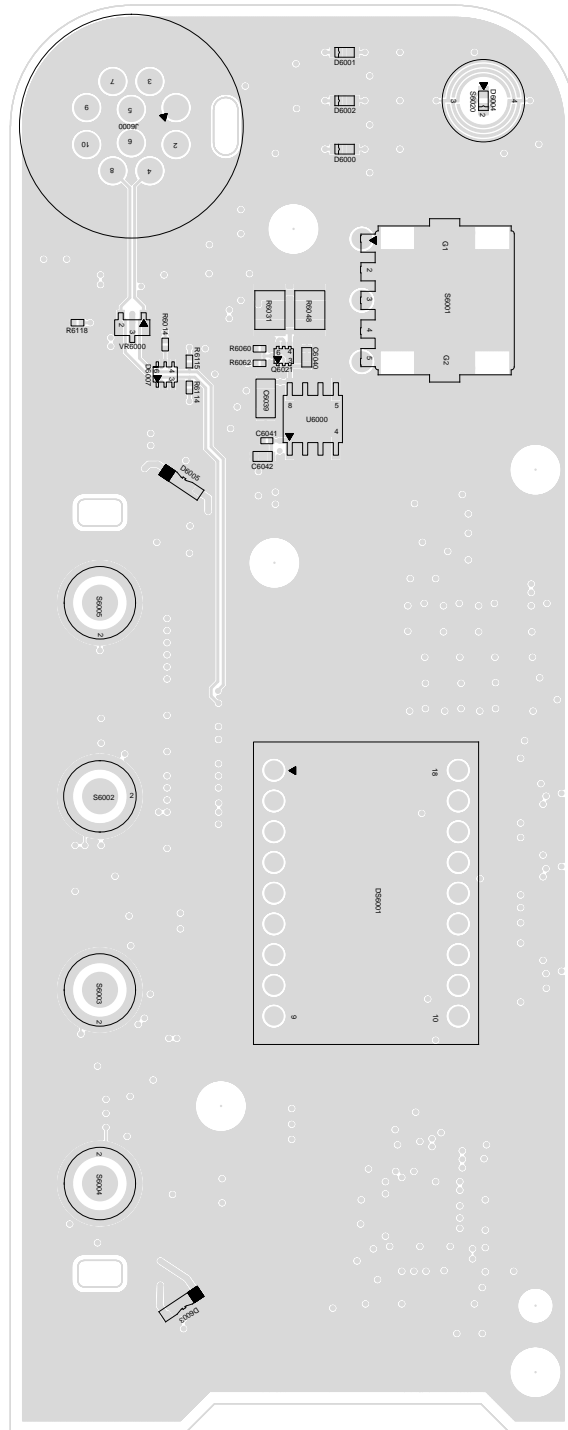

Figure 102: Numeric Display Control Head Bottom Side PCB No. 84012212002-B

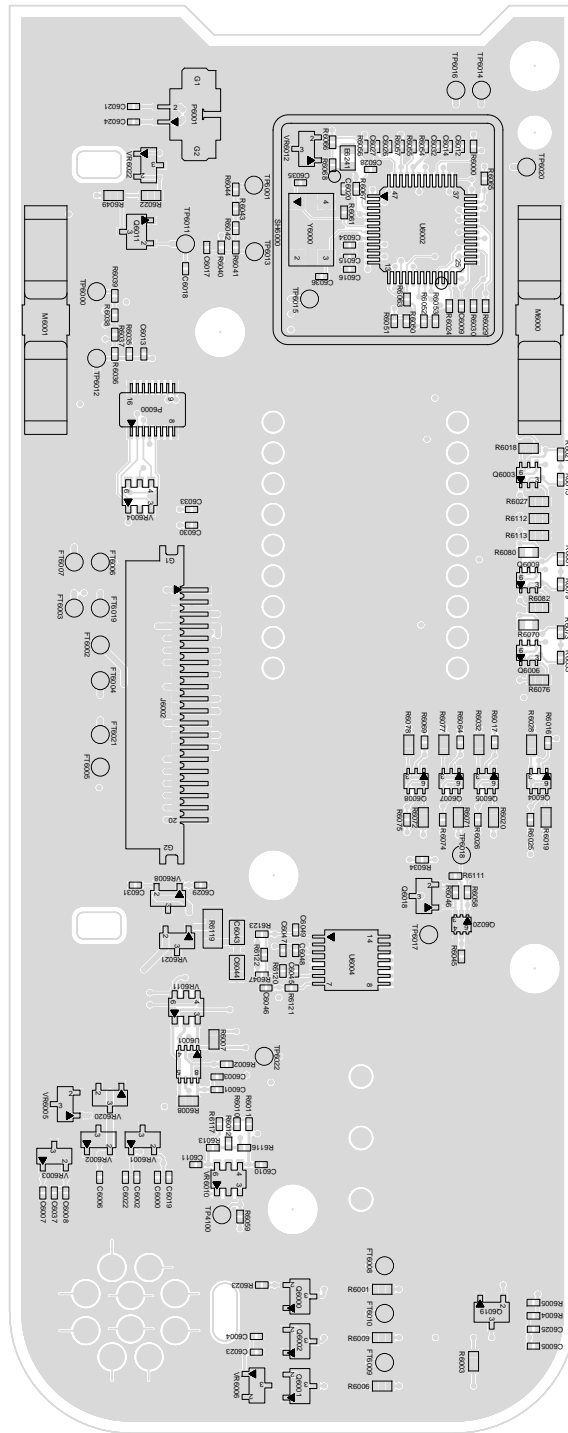
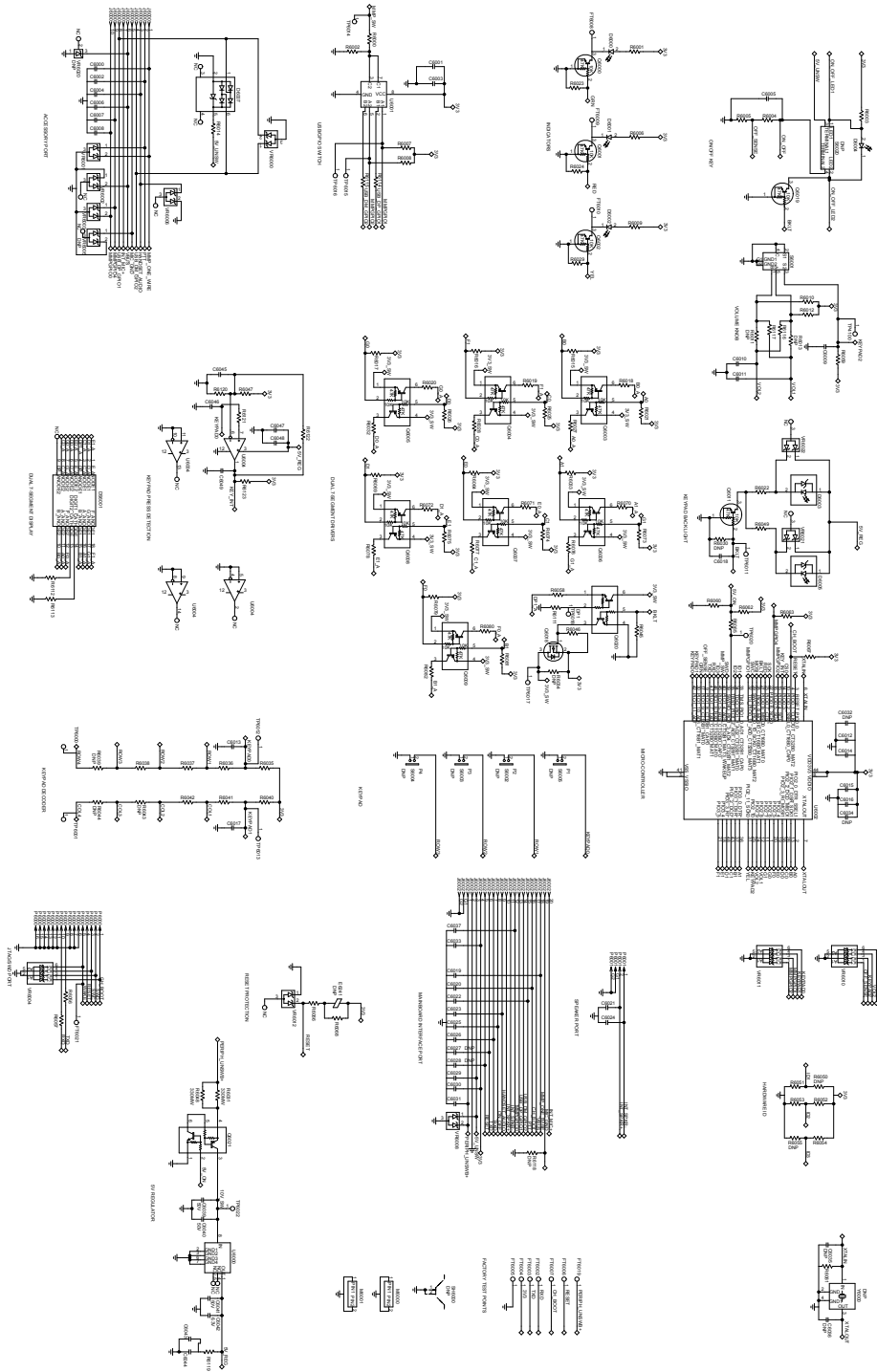

Figure 103: Numeric Display Control Head Schematic Diagram



8.1.1.2

Parts List for Numeric Display Control Head

Table 9: Numeric Display Control Head Parts List (PMLN7500_)

Circuit Ref.	Motorola Solutions Part No.	Circuit Ref.	Motorola Solutions Part No.
C6000	2113945A05	R6021	0613952R01
C6001	2113945B02	R6022	0613952C01
C6002	2113945A05	R6023	0613952R01
C6003	2113946B04	R6024	0613952R01
C6004	2113945A05	R6025	0613952R01
C6005	2113945B02	R6026	0613952R01
C6006	2113945A05	R6027	0613952H44
C6007	2113945A05	R6028	0613952H44
C6008	2113945A05	R6029	0613952R01
C6009	2113945B02	R6030	NOT PLACED
C6010	2113945B02	R6031	0613959G57
C6011	2113945B02	R6032	0613952H44
C6012	2113946B04	R6033	0613952R01
C6013	2113945B02	R6034	NOT PLACED
C6014	2113945B02	R6036	0613952R04
C6015	2113946B04	R6037	0613952R09
C6016	2113945B02	R6038	0613952R17
C6017	2113945B02	R6039	NOT PLACED
C6018	2113946B04	R6040	0613952R18
C6019	2113945A05	R6041	0613952R04
C6020	2113945A05	R6042	0613952R09
C6021	2113945A05	R6043	NOT PLACED
C6022	2113945A05	R6044	NOT PLACED
C6023	2113945A05	R6045	0613952Q89
C6024	2113945A05	R6046	0613952Q89
C6025	2113945A05	R6047	0613952R18
C6026	NOT PLACED	R6048	0613959G57
C6027	NOT PLACED	R6049	0613952C01
C6028	2113945A05	R6050	NOT PLACED
C6029	2113945A05	R6051	0613952R66
C6030	2113945A05	R6052	0613952N01
C6031	2113945A05	R6053	0613952Z44

Circuit Ref.	Motorola Solutions Part No.	Circuit Ref.	Motorola Solutions Part No.
C6032	NOT PLACED	R6054	0613952R66
C6033	2113956A51	R6055	NOT PLACED
C6034	NOT PLACED	R6056	0613952R66
C6035	NOT PLACED	R6057	0613952R66
C6036	NOT PLACED	R6058	0613952Q25
C6037	2113945A05	R6059	0613952R01
C6039	2113955D13	R6060	0613952R01
C6040	2113944C06	R6061	0613952R66
C6041	2113944A44	R6062	0613952Q85
C6042	2113946D05	R6063	0613952R09
C6043	2113956C37	R6064	0613952R01
C6044	2113956C37	R6065	0613952R66
C6045	2113945A05	R6066	0613952Q73
C6046	2113945A05	R6067	0613952R17
C6047	2113945B02	R6068	0613952R66
C6048	2113946B04	R6069	0613952R01
C6049	2113945A05	R6070	0613952H44
D6000	4815809H04	R6071	0613952H44
D6001	4815809H02	R6072	0613952H44
D6002	4815809H03	R6073	0613952R01
D6003	48012173001	R6074	0613952R01
D6004	4815809H04	R6075	0613952R01
D6005	48012173001	R6076	0613952H44
D6007	48012049001	R6077	0613952H44
DS6001	7216958H01	R6078	0613952H44
E6241	NOT PLACED	R6079	0613952R01
J6000	0964501H04	R6080	0613952H44
J6002	0915767H01	R6081	0613952R01
M6000	39012078001	R6082	0613952H44
M6001	39012078001	R6111	0613952R01
P6000	2887818K02	R6112	0613952G67
P6001	2815162H01	R6113	0613952G67
Q6000	4815261H01	R6114	0613952Q73
Q6001	4815261H01	R6115	0613952Q73
Q6002	4815261H01	R6116	0613952R66

Circuit Ref.	Motorola Solutions Part No.	Circuit Ref.	Motorola Solutions Part No.
Q6003	48012232001	R6117	0613952R66
Q6004	48012232001	R6118	NOT PLACED
Q6005	48012232001	R6119	0615871H01
Q6006	48012232001	R6120	0613952R43
Q6007	48012232001	R6121	0613952R01
Q6008	48012232001	R6122	0613952R49
Q6009	48012232001	R6123	0613952Q73
Q6011	4815261H01	S6001	40012062001
Q6018	4885065Y01	S6002	NOT PLACED
Q6019	4815261H01	S6003	NOT PLACED
Q6020	4809939C47	S6004	NOT PLACED
Q6021	4815272H01	S6005	NOT PLACED
R6000	0613952R66	S6020	NOT PLACED
R6001	0613952H47	SH6000	NOT PLACED
R6002	0613952Q85	U6000	5114014A03
R6003	0613952H47	U6001	51012327001
R6004	0613952Q85	U6002	51012145002
R6005	0613952Q93	U6004	5188691V50
R6006	0613952H47	VR6000	48012153001
R6007	0613952J09	VR6001	4813977A43
R6008	0613952J09	VR6002	4813977A43
R6009	0613952H47	VR6003	4813977A43
R6010	0613952R01	VR6004	4813979P10
R6011	NOT PLACED	VR6005	NOT PLACED
R6012	0613952R01	VR6006	4813977A43
R6013	NOT PLACED	VR6008	4813977A50
R6014	0613952R01	VR6010	4813979P10
R6015	0613952R01	VR6011	4813979P10
R6016	0613952R01	VR6012	4813977A43
R6017	0613952R01	VR6020	NOT PLACED
R6018	0613952H44	VR6021	4813977A43
R6019	0613952H44	VR6022	4813977A43
R6020	0613952H44	Y6000	NOT PLACED

8.1.2

Allocation of Schematics and Circuit Boards

This Chapter shows the Schematics and the Parts Lists for the Control Head circuits.

Colour Display Control Head Schematic Diagram and Parts List

Diagrams:

- [Figure 104: Color Display Control Head Top Side PCB No. 84012211002-B on page 136](#)
- [Figure 105: Colour Display Control Head Bottom Side PCB No. 84012211002-B on page 137](#)
- [Figure 106: Color Display Control Head Schematic Diagram on page 138](#)

[Parts List for Color Display Control Head on page 139](#)

8.1.2.1

Color Display Control Head Circuit Board and Schematic Diagram

Figure 104: Color Display Control Head Top Side PCB No. 84012211002-B

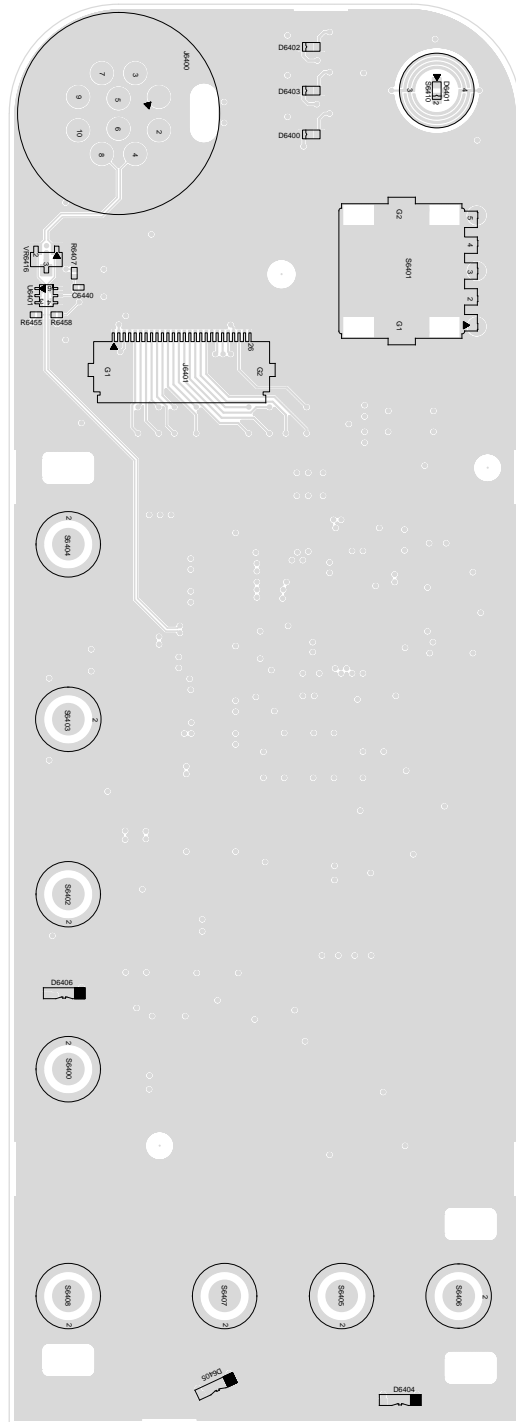

Figure 105: Colour Display Control Head Bottom Side PCB No. 84012211002-B

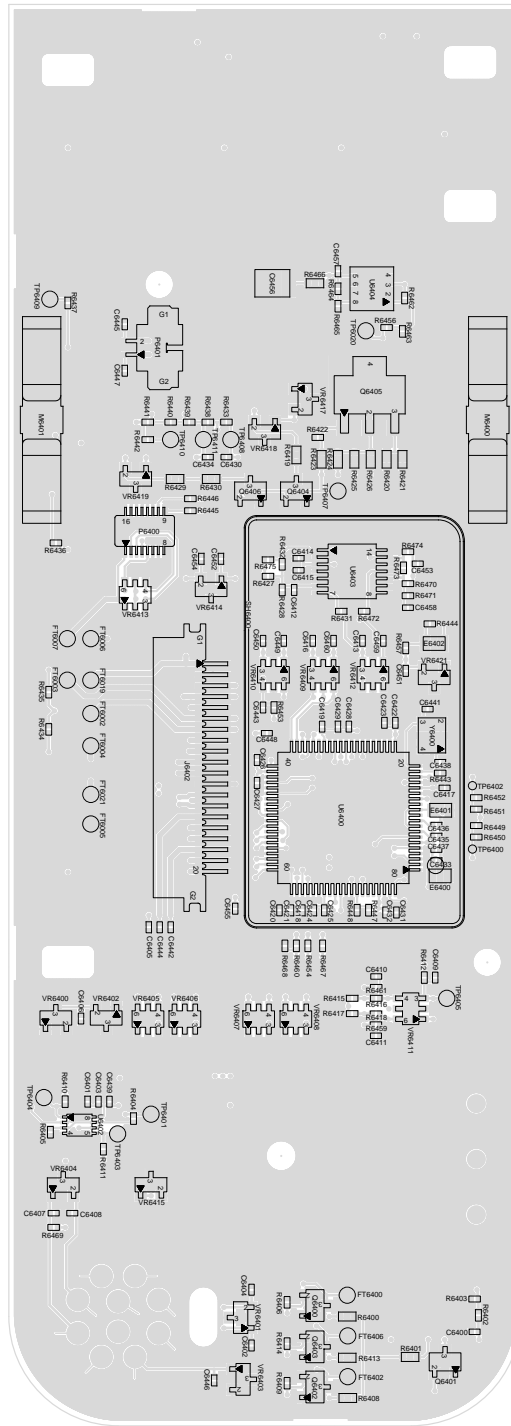
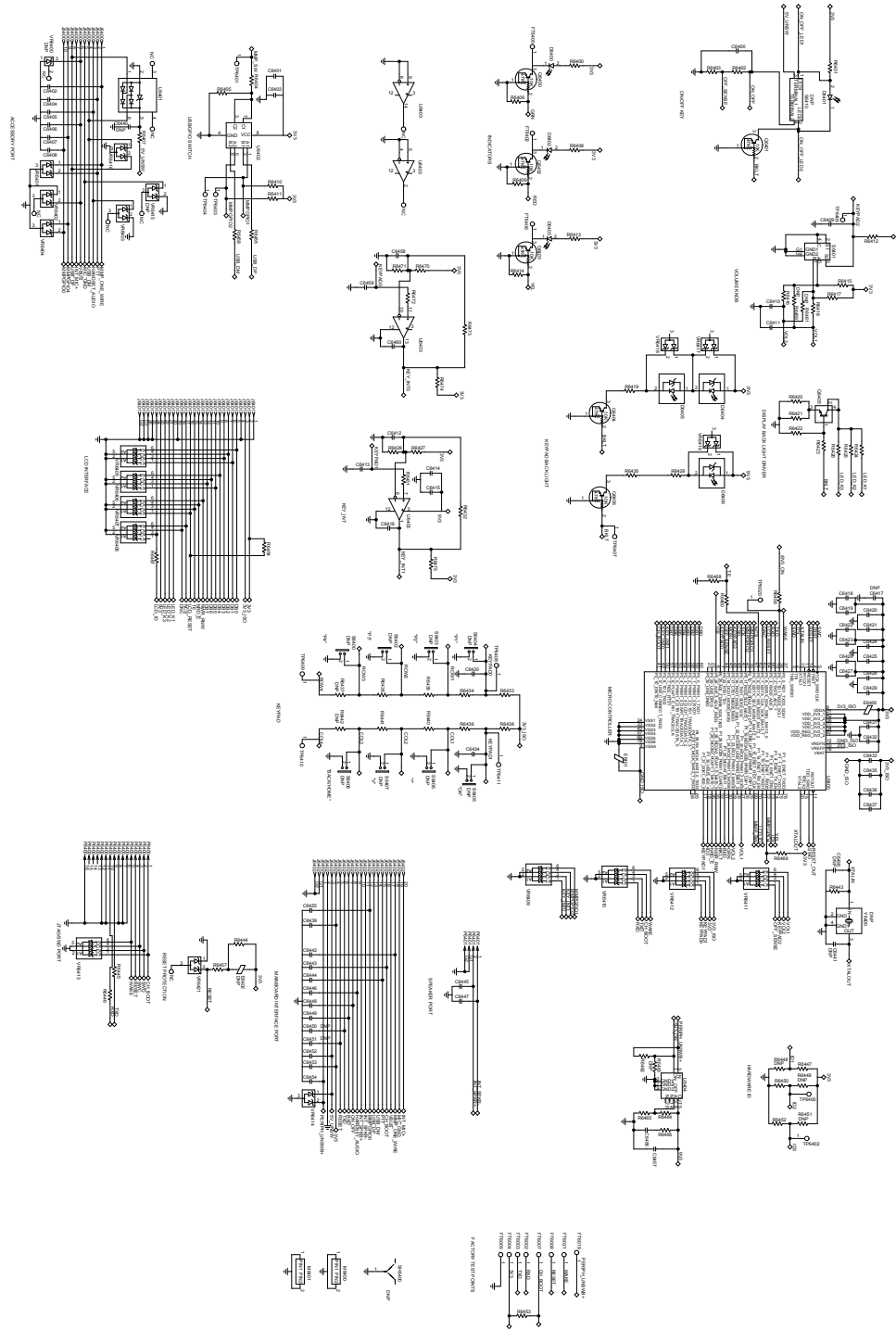

Figure 106: Color Display Control Head Schematic Diagram



8.1.2.2

Parts List for Color Display Control Head

Table 10: Color Display Control Head Parts List (PMLN7501_)

Circuit Ref.	Motorola Solutions Part No.	Circuit Ref.	Motorola Solutions Part No.
C6400	2113945B02	R6415	0613952R01
C6401	2113945B02	R6416	0613952R66
C6402	2113945A05	R6417	0613952R01
C6403	2113946B04	R6418	0613952R66
C6404	2113945A05	R6419	0613952H53
C6405	2113945A05	R6420	0613952H25
C6406	2113945A05	R6421	0613952H25
C6407	2113945A05	R6422	0613952R01
C6408	2113945A05	R6423	0613952H92
C6409	2113945B02	R6424	0613952G67
C6410	2113945B02	R6425	0613952G67
C6411	2113945B02	R6426	0613952G67
C6412	2113945A05	R6427	0613952R18
C6413	2113945A05	R6428	0613952R43
C6414	2113946B04	R6429	0613952H53
C6415	2113945B02	R6430	0613952H53
C6416	2113945A05	R6431	0613952R01
C6417	NOT PLACED	R6432	0613952R49
C6418	2113946B04	R6433	0613952R18
C6419	2113945B02	R6434	0613952R04
C6420	2113946B04	R6435	0613952R09
C6421	2113945B02	R6436	0613952R17
C6422	2113946B04	R6437	NOT PLACED
C6423	2113945B02	R6438	0613952R18
C6424	2113946B04	R6439	0613952R04
C6425	2113945B02	R6440	0613952R09
C6426	2113946B04	R6441	0613952R17
C6427	2113945B02	R6442	NOT PLACED
C6428	2113946B04	R6443	0613952R66
C6429	2113945B02	R6444	0613952R66
C6430	2113945B02	R6445	0613952R66
C6431	2113946B04	R6446	0613952R66

Circuit Ref.	Motorola Solutions Part No.	Circuit Ref.	Motorola Solutions Part No.
C6432	2113945B02	R6447	0613952R66
C6433	2113946B04	R6448	NOT PLACED
C6434	2113945B02	R6449	NOT PLACED
C6435	2113945B02	R6450	0613952R66
C6436	2113946B04	R6451	NOT PLACED
C6437	2113945B02	R6452	0613952R66
C6438	NOT PLACED	R6453	0613952R17
C6439	2113956A51	R6454	0613952Q73
C6440	NOT PLACED	R6455	0613952Q73
C6441	NOT PLACED	R6456	0613952R66
C6442	2113945A05	R6457	0613952Q73
C6443	2113945A05	R6458	0613952Q73
C6444	2113945A05	R6459	NOT PLACED
C6445	2113945A05	R6460	0613952R66
C6446	2113945A05	R6461	NOT PLACED
C6447	2113945A05	R6462	0613952R17
C6448	2113945A05	R6463	NOT PLACED
C6449	NOT PLACED	R6464	0613952M85
C6450	NOT PLACED	R6465	0613952M09
C6451	2113945A05	R6466	0613952A01
C6452	2113945A05	R6467	0613952R01
C6453	2113945A05	R6468	0613952R01
C6454	2113945A05	R6469	0613952R09
C6455	2113945A05	R6470	0613952R18
C6456	2113946J04	R6471	0613952R43
C6457	2113945Y02	R6472	0613952R01
C6458	2113945A05	R6473	0613952R49
C6459	2113945A05	R6474	0613952Q73
C6460	2113945A05	R6475	0613952Q73
D6400	4815809H04	S6400	NOT PLACED
D6401	4815809H04	S6401	40012062001
D6402	4815809H02	S6402	NOT PLACED
D6403	4815809H03	S6403	NOT PLACED
D6404	48012173001	S6404	NOT PLACED
D6405	48012173001	S6405	NOT PLACED

Circuit Ref.	Motorola Solutions Part No.	Circuit Ref.	Motorola Solutions Part No.
D6406	48012173001	S6406	NOT PLACED
E6400	2485410Y02	S6407	NOT PLACED
E6401	2485410Y02	S6408	NOT PLACED
E6402	NOT PLACED	S6410	NOT PLACED
J6400	0964501H04	SH6400	NOT PLACED
J6401	0916769H02	U6400	51012180001
J6402	0915767H01	U6401	48012049001
M6400	39012078001	U6402	51012327001
M6401	39012078001	U6403	5188691V50
P6400	2887818K02	U6404	5171774H01
P6401	2815162H01	VR6400	NOT PLACED
Q6400	4815261H01	VR6401	4813977A43
Q6401	4815261H01	VR6402	4813977A43
Q6402	4815261H01	VR6403	4813977A43
Q6403	4815261H01	VR6404	4813977A43
Q6404	4815261H01	VR6405	4813979P10
Q6405	4813973B01	VR6406	4813979P10
Q6406	4815261H01	VR6407	4813979P10
R6400	0613952H47	VR6408	4813979P10
R6401	0613952H47	VR6409	4813979P10
R6402	0613952Q85	VR6410	4813979P10
R6403	0613952Q93	VR6411	4813979P10
R6404	0613952R66	VR6412	4813979P10
R6405	0613952Q85	VR6413	4813979P10
R6406	0613952R01	VR6414	4813977A50
R6407	0613952R01	VR6415	NOT PLACED
R6408	0613952H47	VR6416	48012153001
R6409	0613952R01	VR6417	4813977A43
R6410	0613952R09	VR6418	4813977A43
R6411	0613952R09	VR6419	4813977A43
R6412	0613952R01	VR6421	4813977A43
R6413	0613952H47	Y6400	NOT PLACED
R6414	0613952R01	-	-

8.2

Controller Service Information

This Chapter shows the Schematics and the Parts Lists of the Controller circuits.

Table 11: PC Boards using Controller R3

PC Board Part Number	Board Revision	Frequency Band
84012734001	A	VHF Low Power
84012734002	A	VHF Low Power
84012736001	A	VHF High Power
84012736002	A	VHF High Power
84012735001	A	UHF1 Low Power
84012735003	A	UHF1 Low Power
84012737001	A	UHF1 High Power
84012737003	A	UHF1 High Power
84012728001	A	UHF2
84012657001	A	800/900 Band

Table 12: PC Boards using Controller R4

PC Board Part Number	Board Revision	Frequency Band
84012734002	B	VHF Low Power
84012736002	B	VHF High Power
84012735003	C	UHF1 Low Power
84012737003	C	UHF1 High Power

Table 13: PC Boards using Controller R5

PC Board Part Number	Board Revision	Frequency Band
84012728003	C	UHF2

8.2.1

Allocation of Schematics and Parts Lists

Controller R3 Schematic Diagrams and Parts Lists

Diagrams:

- [Figure 107: Controller Top Level Schematic Diagram on page 144](#)
- [Figure 108: Controller DC Supply Schematic Diagram on page 145](#)
- [Figure 109: Controller Audio Schematic Diagram on page 146](#)
- [Figure 110: Controller Peripheral Schematic Diagram \(Sheet 1 of 2\) on page 147](#)
- [Figure 111: Controller Peripheral Schematic Diagram \(Sheet 2 of 2\) on page 148](#)
- [Figure 112: Controller Microprocessor Schematic Diagram on page 149](#)

- [Figure 113: Controller Memories Schematic Diagram on page 150](#)
[Parts List for Controller R3 on page 151](#)

Controller R4 Schematic Diagrams and Parts Lists

Diagrams:

- [Figure 114: Controller Top Level Schematic Diagram on page 163](#)
- [Figure 115: Controller DC Supply Schematic Diagram on page 164](#)
- [Figure 116: Controller Audio Schematic Diagram on page 165](#)
- [Figure 117: Controller Peripheral Schematic Diagram \(Sheet 1 of 2\) on page 166](#)
- [Figure 118: Controller Peripheral Schematic Diagram \(Sheet 2 of 2\) on page 167](#)
- [Figure 119: Controller Microprocessor Schematic Diagram on page 168](#)
- [Figure 120: Controller Memories Schematic Diagram on page 169](#)

[Parts List for Controller R4 on page 170](#)

Controller R5 Schematic Diagrams and Parts Lists

Diagrams:

- [Figure 121: Controller Top Level Schematic Diagram on page 182](#)
- [Figure 122: Controller DC Supply Schematic Diagram on page 183](#)
- [Figure 123: Controller Audio Schematic Diagram on page 184](#)
- [Figure 124: Controller Peripheral Schematic Diagram \(Sheet 1 of 2\) on page 185](#)
- [Figure 125: Controller Peripheral Schematic Diagram \(Sheet 2 of 2\) on page 186](#)
- [Figure 126: Controller Microprocessor Schematic Diagram on page 187](#)
- [Figure 127: Controller Memories Schematic Diagram on page 188](#)

[Parts List for Controller R5 on page 189](#)

8.2.1.1
Controller R3 Schematic Diagrams

Figure 107: Controller Top Level Schematic Diagram

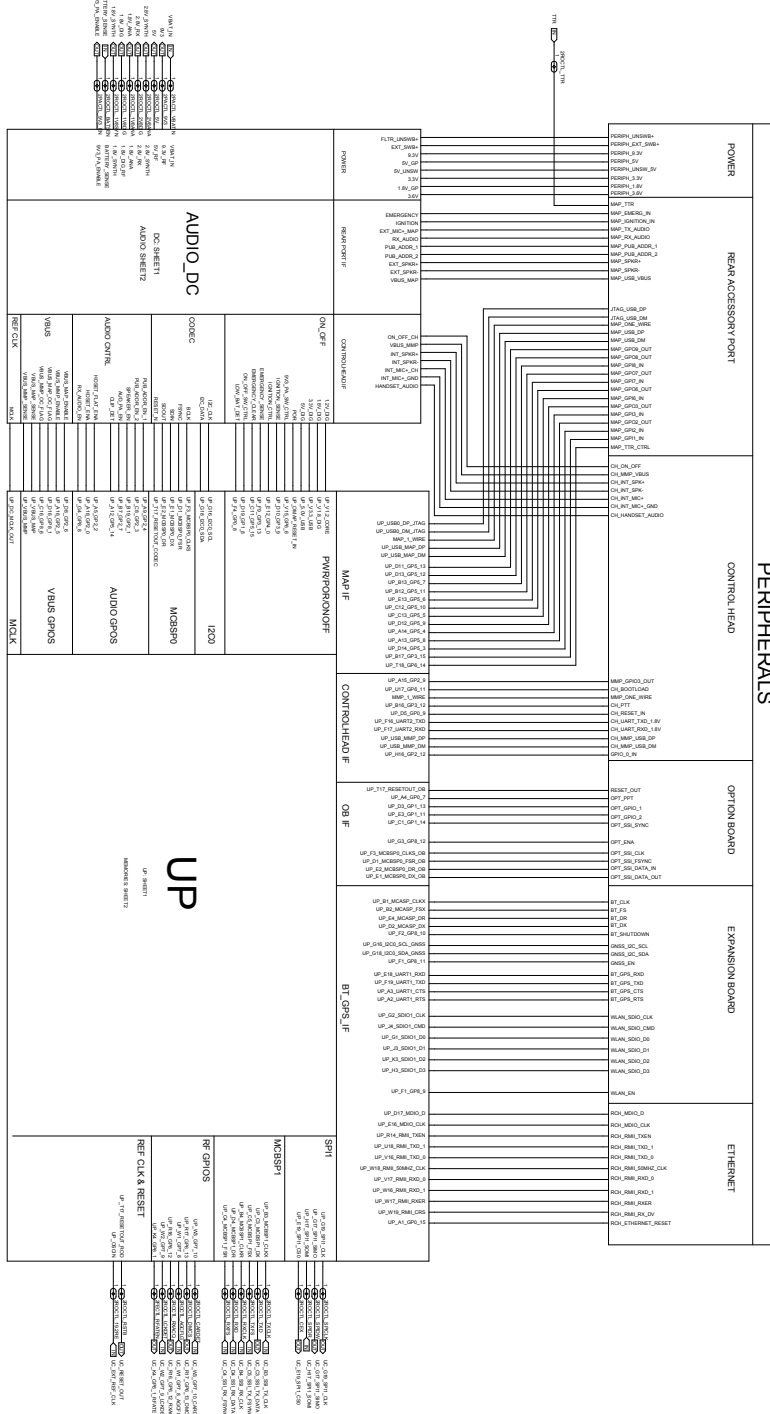

Figure 108: Controller DC Supply Schematic Diagram

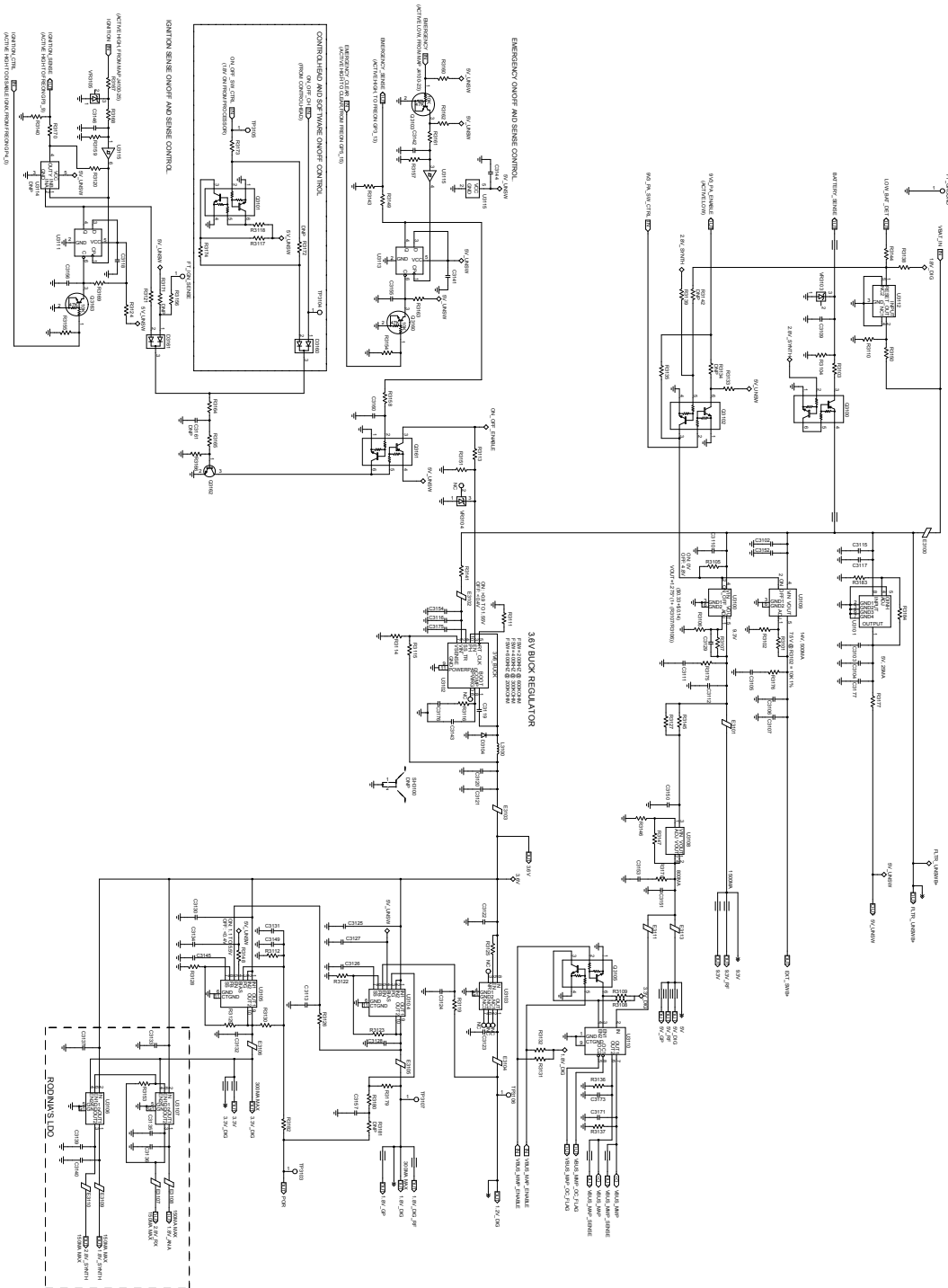

Figure 109: Controller Audio Schematic Diagram



Figure 110: Controller Peripheral Schematic Diagram (Sheet 1 of 2)

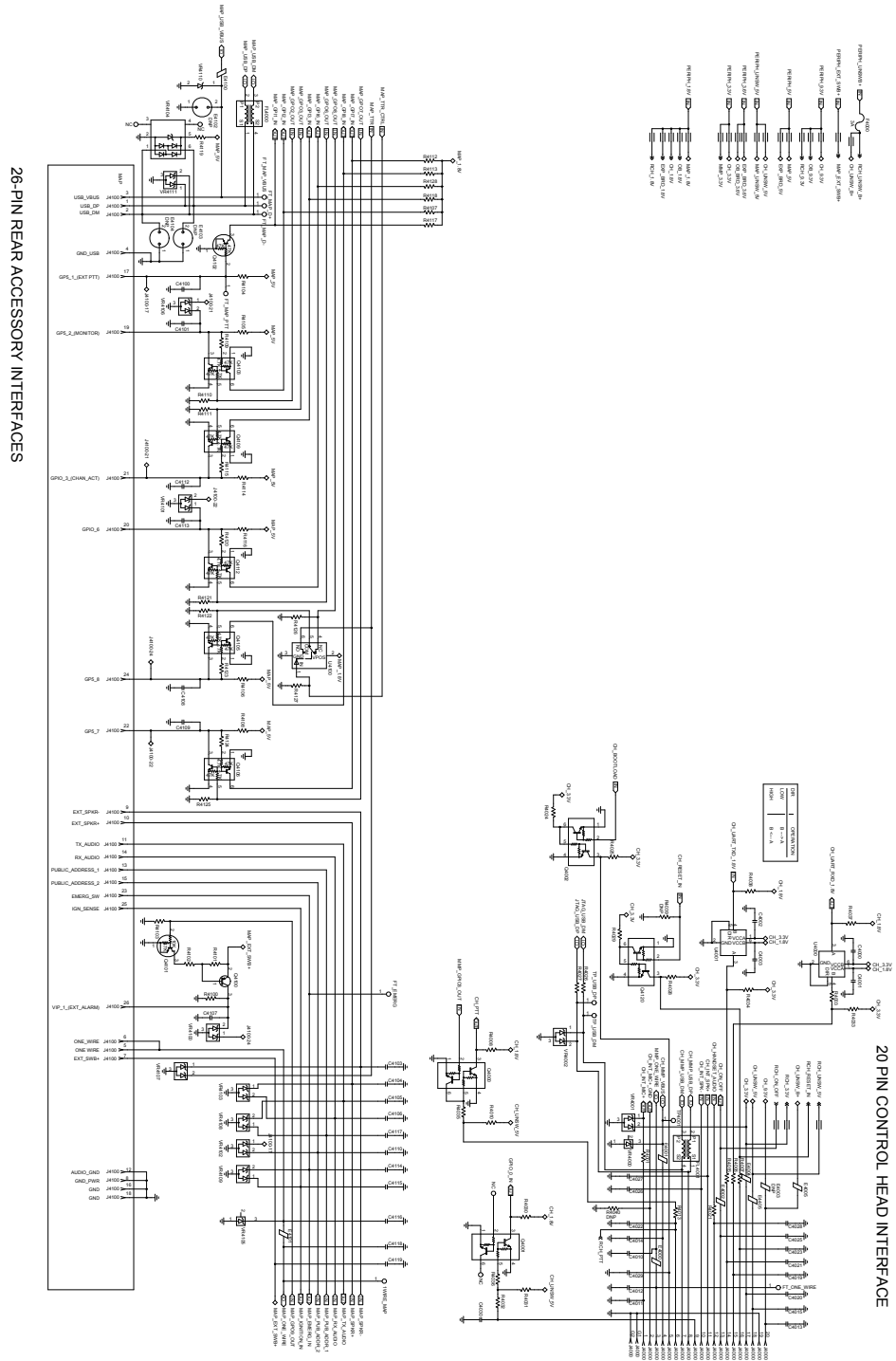

Figure 111: Controller Peripheral Schematic Diagram (Sheet 2 of 2)

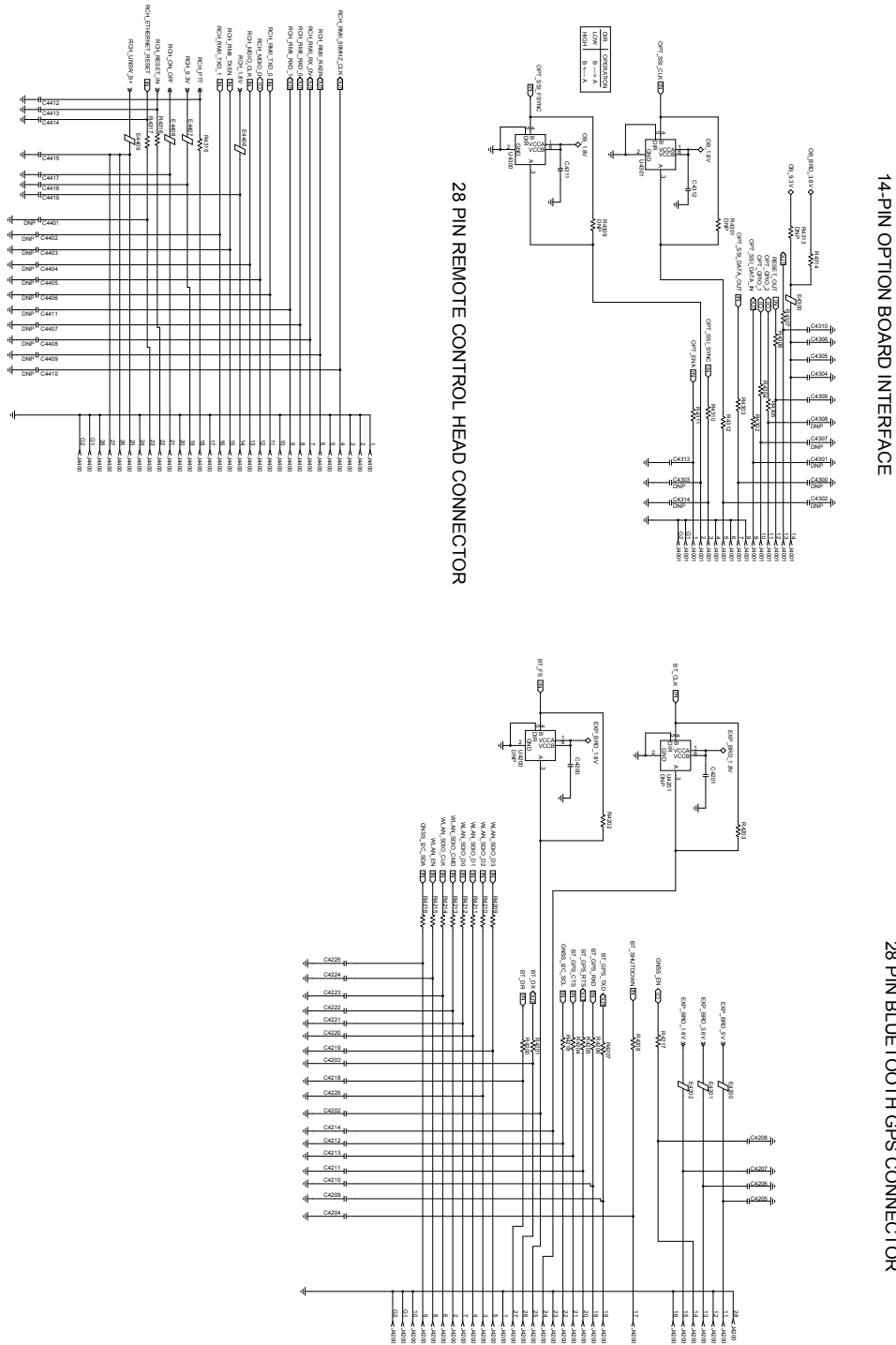

Figure 112: Controller Microprocessor Schematic Diagram

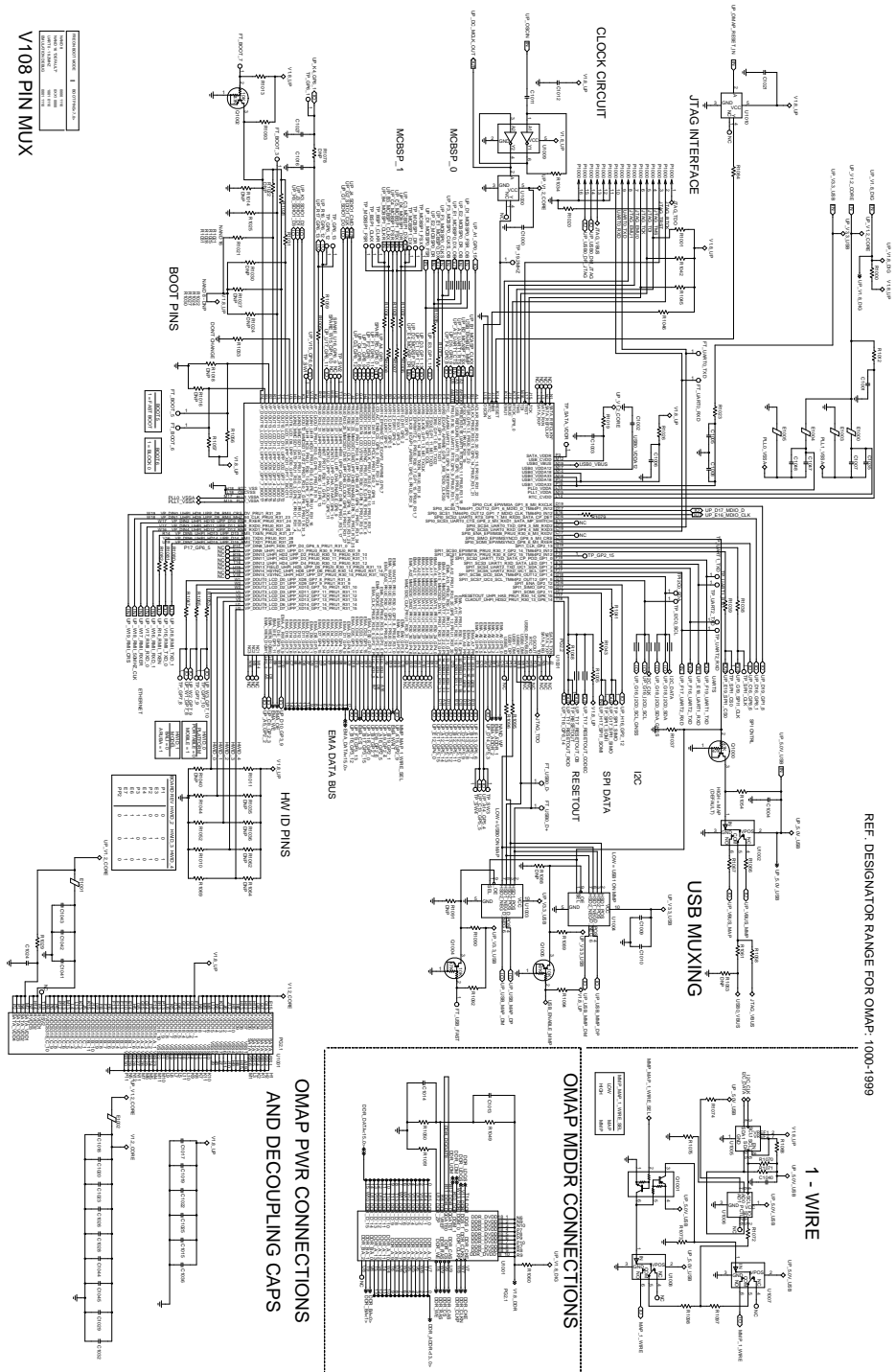
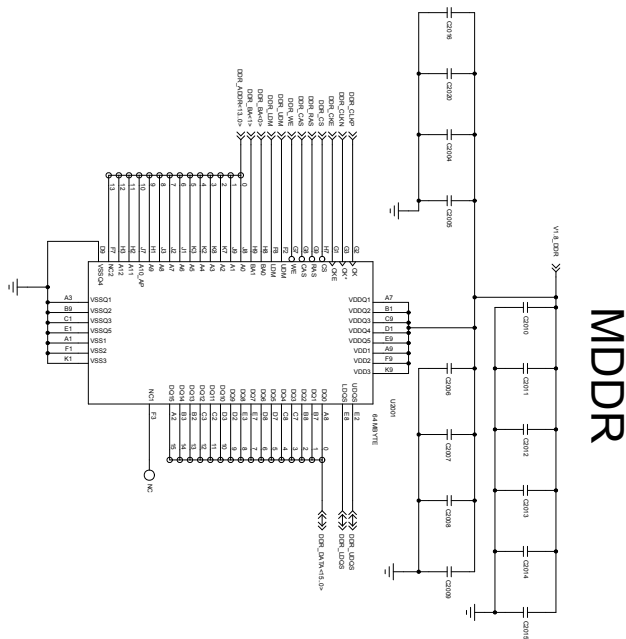
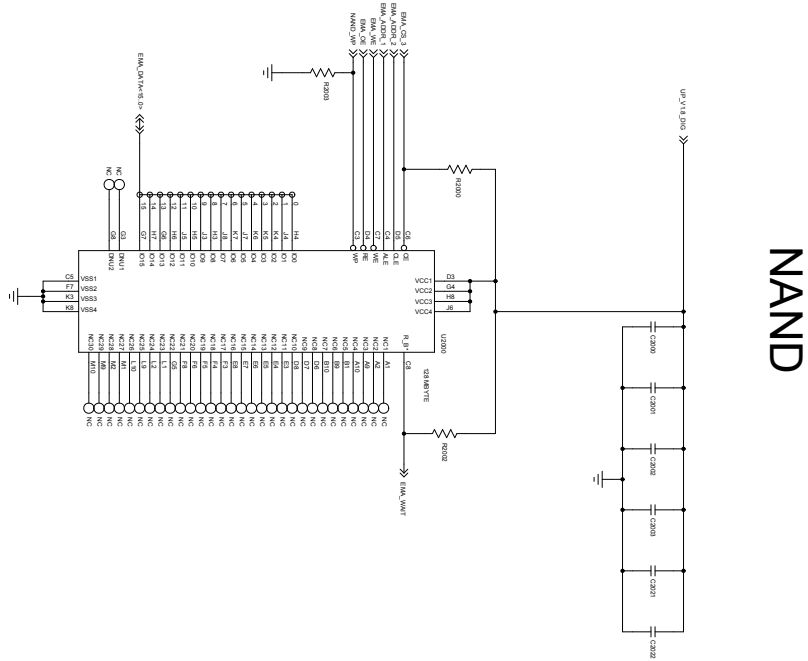

Figure 113: Controller Memories Schematic Diagram



8.2.1.2

Parts List for Controller R3

Table 14: Controller R3 Parts List

Circuit Ref.	Motorola Solutions Part No.	Circuit Ref.	Motorola Solutions Part No.
C1000M1	2113945Y02	R1036M1	NOT PLACED
C1001M1	2113945Y02	R1037M1	0613952M66
C1002M1	2113946K03	R1038M1	0613952R66
C1003M1	2113945Y02	R1039M1	0613952R66
C1004M1	2113945Y02	R1040M1	NOT PLACED
C1005M1	2113945Y02	R1041M1	0613952R66
C1006M1	2113945Y02	R1042M1	0613952M66
C1007M1	2113945Y02	R1043M1	0613952R66
C1008M1	2113946D05	R1044M1	0613952M66
C1009M1	2113945Y02	R1045M1	0613952M66
C1010M1	2113945Y02	R1046M1	0613952M66
C1011M1	2113945B02	R1047M1	0613952R66
C1012M1	2113945Y02	R1048M1	0613952R66
C1013M1	2113945Y02	R1049M1	0613952Q73
C1014M1	2113945Y02	R1050M1	0613952Q73
C1015M1	2113945B02	R1051M1	0613952K68
C1016M1	21667009166	R1052M1	0613952M66
C1017M1	21667009162	R1053M1	0613952R66
C1018M1	21667009162	R1054M1	0613952M66
C1019M1	21667009162	R1056M1	0613952Q73
C1020M1	21667009162	R1057M1	0613952Q73
C1021M1	2113945Y02	R1058M1	0613952M66
C1022M1	2113945Y02	R1059M1	0613952R66
C1023M1	2113945Y02	R1060M1	0613952R66
C1024M1	2113945Y02	R1061M1	0613952R66
C1025M1	2113945Y02	R1062M1	NOT PLACED
C1026M1	2113945Y02	R1063M1	NOT PLACED
C1027M1	NOT PLACED	R1064M1	NOT PLACED
C1028M1	2113945Y02	R1065M1	0613952R66
C1029M1	2113956B54	R1066M1	0613952M66
C1032M1	2113956B54	R1067M1	0613952M66
C1035M1	2113945B02	R1068M1	0613952R32

Circuit Ref.	Motorola Solutions Part No.	Circuit Ref.	Motorola Solutions Part No.
C1036M1	2113946D05	R1069M1	0613952M66
C1040M1	2113945Y02	R1070M1	0613952Q77
C1041M1	2113945B02	R1071M1	0613952Q77
C1042M1	2113945Y02	R1072M1	0613952Q49
C1043M1	2113956B54	R1073M1	0613952R01
C1044M1	2113945B02	R1074M1	0613952R66
C1045M1	2113945B02	R1075M1	0613952R66
C1047M1	2113945Y02	R1076M1	0613952R66
C1048M1	2113945B02	R1077M1	0613952R66
C2000M1	2113945Y02	R1078M1	0613952R66
C2001M1	2113945Y02	R1079M1	0613952R66
C2002M1	2113945B02	R1080M1	0613952Q32
C2003M1	21667009162	R1081M1	0613952Q32
C2004M1	2113956B54	R1082M1	0613952Q32
C2005M1	2113946D05	R1084M1	0613952R66
C2006M1	2113945Y02	R1088M1	NOT PLACED
C2007M1	2113945Y02	R1089M1	0613952R05
C2008M1	2113945B02	R1090M1	0613952R05
C2009M1	21667009162	R1091M1	NOT PLACED
C2010M1	2113945Y02	R1092M1	0613952M43
C2011M1	2113945Y02	R1093M1	0613952Q73
C2012M1	2113945Y02	R1094M1	0613952M66
C2013M1	2113945Y02	R1095M1	0613952Q34
C2014M1	2113945B02	R1096M1	0613952Q34
C2015M1	21667009162	R1097M1	0613952R66
C2016M1	2113956B54	R1098M1	0613952R66
C2020M1	2113956B54	R2000M1	0613952M66
C2021M1	2113956D59	R2002M1	0613952M66
C2022M1	2113956D59	R2003M1	0613952M30
C3102M1	21009337414	R3101M1	0613952Z66
C3103M1	21667009166	R3102M1	0613952M66
C3104M1	2113946F08	R3103M1	0613952N62
C3105M1	2113946J04	R3104M1	0613952M30
C3106M1	2113945C31	R3105M1	0613952R01
C3107M1	2113944C38	R3106M1	0613952M09

Circuit Ref.	Motorola Solutions Part No.	Circuit Ref.	Motorola Solutions Part No.
C3109M1	21667009166	R3107M1	0613952M85
C3110M1	2113944C06	R3108M1	0613952R17
C3111M1	2113946J04	R3109M1	0613952R17
C3112M1	2113945Y02	R3110M1	0613952N55
C3113M1	2113946S35	R3111M1	0613952R32
C3115M1	2113944C06	R3112M1	0613952P12
C3116M1	2113955D13	R3113M1	0613952R17
C3117M1	2113955D13	R3114M1	0613952N01
C3118M1	2113945Y02	R3115M1	0613952Z63
C3119M1	2113945Y02	R3116M1	0613952E83
C3120M1	2113956E60	R3117M1	0613952Q73
C3121M1	2113956D58	R3118M1	0613952R10
C3122M1	2113956A51	R3119M1	0613952Q73
C3123M1	2113956A51	R3120M1	0613952R66
C3124M1	2113946D07	R3121M1	0613952R66
C3125M1	2113946D05	R3122M1	0613952M43
C3126M1	2113944C06	R3123M1	0613952M54
C3127M1	2113946S35	R3124M1	0613952R66
C3128M1	2113946D05	R3125M1	0613952R66
C3129M1	2113945Y02	R3126M1	0613952R66
C3130M1	2113946D05	R3127M1	0613959Y09
C3131M1	2113946A02	R3128M1	0613952M10
C3132M1	2113946D05	R3129M1	0613952M58
C3133M1	2113946D05	R3130M1	0613952R25
C3134M1	2113946S35	R3131M1	0613952R01
C3135M1	2113956A51	R3132M1	0613952R01
C3136M1	21012095001	R3133M1	0613952R29
C3137M1	2113946D05	R3134M1	NOT PLACED
C3139M1	2113956A51	R3135M1	0613952R66
C3140M1	21012095001	R3136M1	0613952R17
C3141M1	2113945Y02	R3137M1	0613952R17
C3142M1	21012102001	R3138M1	0613952R17
C3143M1	21667009366	R3139M1	0613952R66
C3144M1	2113945Y02	R3140M1	0613952Q91
C3145M1	2113944C06	R3141M1	0613959Y13

Circuit Ref.	Motorola Solutions Part No.	Circuit Ref.	Motorola Solutions Part No.
C3146M1	21012102001	R3142M1	NOT PLACED
C3149M1	2113956A51	R3143M1	0613952Q91
C3150M1	2113956C37	R3144M1	0613952R66
C3151M1	2113945B02	R3145M1	0613959Y09
C3152M1	2113944C06	R3146M1	0613952M85
C3153M1	2113946J04	R3147M1	0613952M43
C3154M1	2113955D13	R3148M1	0613952R66
C3155M1	2113945Y02	R3149M1	0613952R01
C3156M1	2113945Y02	R3150M1	0613952N62
C3157M1	2113945Y02	R3151M1	0613952R25
C3160M1	2113945Y02	R3153M1	0613952R66
C3161M1	NOT PLACED	R3154M1	0613952Q89
C3171M1	2113946D07	R3155M1	0613952Q89
C3173M1	2113946D07	R3156M1	0613952R17
C3175M1	2113946A01	R3157M1	0613952R01
C3176M1	2113944C48	R3158M1	0613952R66
C3177M1	2113946F08	R3159M1	0613952R01
C3200M1	21667009166	R3160M1	0613952Q89
C3201M1	21667009166	R3161M1	0613952Q73
C3203M1	2113955D37	R3162M1	0613952Q85
C3204M1	2113955D37	R3163M1	0613952R01
C3205M1	21667009166	R3164M1	0613952Q75
C3206M1	21667009166	R3165M1	0613952R01
C3208M1	2113956C37	R3166M1	0613952R17
C3209M1	2113945Y02	R3167M1	0613952R01
C3210M1	2113945Y02	R3168M1	0613952Q73
C3211M1	2113945A11	R3169M1	0613952R01
C3212M1	2113955D37	R3170M1	0613952R01
C3213M1	2113945A03	R3171M1	NOT PLACED
C3214M1	2113955D37	R3172M1	NOT PLACED
C3215M1	2113956F49	R3173M1	0613952R66
C3216M1	2113945Y02	R3174M1	0613952R66
C3217M1	2113956B91	R3175M1	0689774Y02
C3218M1	2113956A51	R3176M1	0689774Y02
C3219M1	2113956A51	R3177M1	0613952R66

Circuit Ref.	Motorola Solutions Part No.	Circuit Ref.	Motorola Solutions Part No.
C3220M1	2113946F05	R3178M1	0615871H01
C3221M1	2113945Y02	R3179M1	0613952R17
C3222M1	2113956A51	R3180M1	0613952R01
C3223M1	2113945Y02	R3181M1	NOT PLACED
C3224M1	2113946F05	R3182M1	0613952R66
C3225M1	2113945Y02	R3183M1	0613952H92
C3226M1	NOT PLACED	R3184M1	0613952M30
C3227M1	2113946F05	R3200M1	0613952C44
C3228M1	2113945Y02	R3201M1	0613952Q49
C3229M1	2113956A51	R3202M1	0613952C44
C3230M1	2113945Y02	R3203M1	0613952Q49
C3231M1	2113945Y02	R3204M1	0613952C44
C3232M1	2113945Y02	R3205M1	0613952C44
C3233M1	2113945A09	R3206M1	0613952R01
C3234M1	2113945Y02	R3207M1	0613952R01
C3235M1	21012102001	R3208M1	0613952N30
C3236M1	2113945C31	R3209M1	0613952R03
C3237M1	21009337414	R3210M1	0613952Q67
C3238M1	2113945A09	R3211M1	0613952N30
C3239M1	2113945A09	R3212M1	0613952R03
C3240M1	2113956B91	R3213M1	0613952Q42
C3241M1	2113956B91	R3214M1	0613952J25
C3242M1	2113945C31	R3215M1	0613952R01
C3243M1	2113955D37	R3216M1	0613952R17
C3244M1	2113956B91	R3217M1	0613952R01
C3245M1	2113955D37	R3218M1	0613952R01
C3246M1	2113945C31	R3219M1	NOT PLACED
C3247M1	2113945Y02	R3220M1	0613952R01
C3248M1	2113945Y02	R3221M1	NOT PLACED
C3249M1	2113956B91	R3222M1	0613952R01
C3250M1	2113956B91	R3223M1	0613952R66
C4000M1	2113945Y02	R3224M1	NOT PLACED
C4001M1	2113945Y02	R3225M1	NOT PLACED
C4002M1	2113945Y02	R3226M1	0613952R01
C4003M1	2113945Y02	R3229M1	0613952R01

Circuit Ref.	Motorola Solutions Part No.	Circuit Ref.	Motorola Solutions Part No.
C4010M1	21667009166	R3230M1	0613952R10
C4011M1	21667009166	R3231M1	0613952R10
C4012M1	21667009166	R3232M1	0613952R10
C4013M1	21667009166	R3233M1	0613952R01
C4014M1	21667009166	R3234M1	NOT PLACED
C4015M1	21667009166	R3235M1	0613952R01
C4019M1	21667009166	R3236M1	0613952R10
C4020M1	21667009166	R3237M1	NOTPLACED
C4021M1	21667009166	R3238M1	0613952R01
C4022M1	21667009166	R3239M1	0613952Q49
C4023M1	21667009166	R3240M1	0613952R01
C4025M1	21667009166	R3241M1	0613952M54
C4026M1	21667009166	R3242M1	0613952R01
C4027M1	21667009166	R3243M1	0613952R01
C4028M1	21667009166	R3244M1	0613952R10
C4029M1	21667009166	R3245M1	NOT PLACED
C4030M1	21667009166	R3246M1	0613952R01
C4100M1	21667009166	R3247M1	0613952Q49
C4101M1	21667009166	R3248M1	0613952R66
C4103M1	21667009166	R3249M1	0613952R66
C4104M1	21667009166	R3250M1	0613952R66
C4105M1	21667009166	R3251M1	0613952R66
C4106M1	21667009166	R3252M1	0613952R66
C4107M1	21667009166	R3253M1	0613952R66
C4108M1	21667009166	R3254M1	0613952R01
C4109M1	21667009166	R3255M1	0613952R66
C4110M1	21667009166	R3256M1	0613952M66
C4112M1	21667009166	R3257M1	0613952R01
C4113M1	21667009166	R3258M1	0613952M66
C4114M1	21667009166	R3259M1	0613952M66
C4115M1	21667009166	R3260M1	0613952M66
C4116M1	21667009166	R3261M1	0613952R01
C4117M1	21667009166	R3262M1	0613952R10
C4118M1	21667009166	R3263M1	NOT PLACED
C4119M1	21667009166	R3264M1	0613952R01

Circuit Ref.	Motorola Solutions Part No.	Circuit Ref.	Motorola Solutions Part No.
C4200M1	2113945Y02	R3265M1	0613952M66
C4201M1	2113945Y02	R3266M1	0613952R01
C4202M1	21667009166	R3267M1	NOT PLACED
C4203M1	21667009166	R3268M1	0613952R01
C4204M1	21667009166	R3269M1	0613952M66
C4205M1	21667009166	R3270M1	0613952R01
C4206M1	21667009166	R3271M1	NOT PLACED
C4207M1	21667009166	R3272M1	0613952R01
C4208M1	21667009166	R3273M1	0613952M66
C4209M1	21667009166	R3274M1	0613952R10
C4210M1	21667009166	R3275M1	0613952R10
C4211M1	21667009166	R3276M1	0613952R10
C4212M1	21667009166	R3277M1	0613952R10
C4213M1	21667009166	R3278M1	0613952R01
C4214M1	21667009166	R3279M1	NOT PLACED
C4218M1	21667009166	R3280M1	NOT PLACED
C4219M1	21667009166	R3281M1	NOT PLACED
C4220M1	21667009166	R3282M1	0613952R66
C4221M1	21667009166	R3283M1	0613952R66
C4222M1	21667009166	R3285M1	0613952R01
C4223M1	21667009166	R3286M1	0613952R66
C4224M1	21667009166	R3287M1	0613952R66
C4225M1	21667009166	R3288M1	0613952R01
C4226M1	21667009166	R3289M1	0613952R01
C4300M1	NOT PLACED	R3290M1	NOT PLACED
C4301M1	NOT PLACED	R3291M1	NOT PLACED
C4302M1	NOT PLACED	R3292M1	0613952R66
C4303M1	NOT PLACED	R3293M1	0613952R66
C4304M1	21667009166	R4001M1	0613952R66
C4305M1	21667009376	R4003M1	0613952R66
C4306M1	21667009381	R4006M1	0613952Q37
C4307M1	NOT PLACED	R4007M1	0613952Q37
C4308M1	NOT PLACED	R4008M1	0613952R01
C4309M1	21667009166	R4010M1	0613952R01
C4310M1	21667009166	R4013M1	0613952Q42

Circuit Ref.	Motorola Solutions Part No.	Circuit Ref.	Motorola Solutions Part No.
C4311M1	2113945Y02	R4015M1	0613952Q37
C4312M1	2113945Y02	R4021M1	0613952R66
C4313M1	21667009166	R4024M1	0613952R01
C4314M1	NOT PLACED	R4025M1	0613952R01
C4401M1	NOT PLACED	R4026M1	0613952R66
C4402M1	NOT PLACED	R4027M1	0613952R66
C4403M1	NOT PLACED	R4028M1	0613952R01
C4404M1	NOT PLACED	R4029M1	0613952R01
C4405M1	NOT PLACED	R4030M1	0613952R01
C4406M1	NOT PLACED	R4031M1	0613952R01
C4407M1	NOT PLACED	R4032M1	0613952R66
C4408M1	NOT PLACED	R4033M1	0613952M43
C4409M1	NOT PLACED	R4034M1	0613952M43
C4410M1	NOT PLACED	R4035M1	0613952R66
C4411M1	NOT PLACED	R4036M1	0613952R66
C4412M1	21667009166	R4037M1	0613952R01
C4413M1	21667009166	R4038M1	0613952R01
C4414M1	21667009166	R4039M1	NOT PLACED
C4415M1	21667009166	R4040M1	NOT PLACED
C4417M1	21667009166	R4041M1	NOT PLACED
C4418M1	21667009166	R4100M1	0613952R01
C4419M1	21667009166	R4101M1	0613952Q77
D3104M1	4885489Y01	R4102M1	0613958H83
D3160M1	4813978C02	R4103M1	0613952Q85
D3161M1	4813978C02	R4104M1	0613952Q89
E1000M1	7686949J15	R4105M1	0613952Q89
E1001M1	7686949J15	R4106M1	0613952Q89
E1002M1	7686949J15	R4107M1	0613952R01
E1003M1	7686949J15	R4108M1	0613952Q89
E1004M1	7686949J15	R4109M1	0613952N58
E1005M1	7686949J15	R4110M1	0613952Q85
E1006M1	7685268E01	R4111M1	0613952Q85
E3100M1	24012102001	R4112M1	0613952R01
E3101M1	2485410Y02	R4113M1	0613952R01
E3102M1	2485410Y02	R4114M1	0613952Q89

Circuit Ref.	Motorola Solutions Part No.	Circuit Ref.	Motorola Solutions Part No.
E3103M1	2485410Y02	R4115M1	0613952N58
E3104M1	7686949J22	R4116M1	0613952Q89
E3105M1	7686949J22	R4117M1	0613952R01
E3106M1	7686949J22	R4118M1	0613952R01
E3107M1	7686949J22	R4119M1	0613952R01
E3108M1	7686949J22	R4120M1	0613952N58
E3109M1	7686949J22	R4121M1	0613952Q85
E3110M1	7686949J22	R4122M1	0613952Q85
E3111M1	7686949J22	R4123M1	0613952N58
E3113M1	7686949J22	R4124M1	0613952N58
E3200M1	24012102001	R4125M1	0613952Q85
E3201M1	24012102001	R4126M1	0613952Q85
E3202M1	24012107027	R4127M1	0613952Q85
E3203M1	24012102001	R4128M1	0613952R01
E3204M1	24012102001	R4200M1	0613952R66
E4000M1	24012107027	R4201M1	0613952R66
E4001M1	7688697V05	R4202M1	0613952R66
E4002M1	24012107027	R4203M1	0613952R66
E4003M1	NOT PLACED	R4204M1	0613952R66
E4004M1	24012102001	R4205M1	0613952R66
E4005M1	2485410Y02	R4206M1	0613952R66
E4100M1	7686949J14	R4207M1	0613952R66
E4101M1	24012107027	R4208M1	0613952R66
E4102M1	NOT PLACED	R4209M1	0613952R66
E4103M1	NOT PLACED	R4210M1	0613952R66
E4104M1	NOT PLACED	R4211M1	0613952R66
E4200M1	24012107027	R4212M1	0613952R66
E4201M1	24012107027	R4213M1	0613952R66
E4202M1	24012107027	R4214M1	0613952R66
E4300M1	24012107027	R4215M1	0613952R66
E4405M1	24012107027	R4216M1	0613952R66
E4406M1	7686949J22	R4217M1	0613952R66
E4407M1	7686949J22	R4218M1	0613952R66
E4408M1	24012107027	R4301M1	NOT PLACED
E4409M1	24012102001	R4302M1	0613952R66

Circuit Ref.	Motorola Solutions Part No.	Circuit Ref.	Motorola Solutions Part No.
F4000M1	65012019001	R4303M1	0613952R66
FL4000M1	24012038001	R4304M1	0613952R66
FL4001M1	24012038001	R4305M1	0613952R66
J4000M1	0915767H01	R4306M1	0613952R66
J4001M1	0915556H01	R4307M1	0613952R66
J4100M1	0916017H01	R4309M1	NOT PLACED
J4200M1	09012053001	R4310M1	0613952R66
J4400M1	09012053001	R4311M1	0613952R66
L3100M1	24012091002	R4312M1	0613952R66
P1000M1	NOTPLACED	R4313M1	NOT PLACED
Q1000M1	4815263H01	R4314M1	0613952R66
Q1001M1	4815272H01	R4315M1	0613952R66
Q1002M1	4815261H01	R4316M1	0613952R66
Q1004M1	4815261H01	R4317M1	0613952R66
Q1005M1	4815261H01	SH3100M1	NOT PLACED
Q3100M1	4815272H01	U1000M1	5171320H01
Q3101M1	4809939C47	U1001M1	51012295001
Q3102M1	4809939C47	U1002M1	5189139P01
Q3103M1	48009494001	U1003M1	5175772B56
Q3105M1	4809939C47	U1004M1	5175772B56
Q3160M1	48009494001	U1005M1	5164852H47
Q3161M1	4815272H01	U1006M1	5185493Y01
Q3162M1	4813973M07	U1007M1	5189139P01
Q3163M1	48009494001	U1008M1	5189139P01
Q3200M1	4815270H01	U1009M1	5115001H02
Q3201M1	4815272H01	U1010M1	5171320H01
Q3202M1	4815270H01	U2000M1	51012239006
Q3203M1	4815270H01	U2001M1	51012058005
Q3204M1	4815270H01	U3100M1	0104039J08
Q3205M1	4815270H01	U3101M1	5114014A01
Q3206M1	4815270H01	U3102M1	51012069001
Q3207M1	4815270H01	U3103M1	51012142001
Q3208M1	4815263H01	U3104M1	5114610F01
Q4000M1	4809939C47	U3105M1	5114610F01
Q4001M1	4809939C47	U3106M1	51012140001

Circuit Ref.	Motorola Solutions Part No.	Circuit Ref.	Motorola Solutions Part No.
Q4002M1	4809939C47	U3107M1	51012140001
Q4100M1	4816023H01	U3108M1	51012138001
Q4101M1	4815261H01	U3109M1	5164015H94
Q4102M1	4815263H01	U3110M1	51012208001
Q4103M1	48012271001	U3111M1	5188690V02
Q4105M1	48012271001	U3112M1	5114004A35
Q4106M1	48012271001	U3113M1	5188690V02
Q4109M1	48012271001	U3114M1	NOT PLACED
Q4112M1	48012271001	U3115M1	5185937Y01
Q4120M1	4809939C47	U3200M1	51009415001
R1000M1	0613952R66	U3201M1	5114016A18
R1001M1	0613952M66	U3204M1	51009509001
R1002M1	0613952R66	U3205M1	5114016A18
R1003M1	0613952R66	U4000M1	51012082001
R1004M1	0613952R66	U4001M1	51012082001
R1005M1	0613952M66	U4100M1	5189139P01
R1007M1	0613952R66	U4200M1	NOT PLACED
R1008M1	0613952R66	U4201M1	NOT PLACED
R1009M1	0613952R66	U4300M1	51012082001
R1010M1	0613952M66	U4301M1	51012082001
R1011M1	0613952M66	VR3103M1	48012095001
R1012M1	0613952R66	VR3104M1	48012095002
R1013M1	0613952M66	VR3105M1	4813977M10
R1014M1	NOT PLACED	VR3200M1	48012049001
R1016M1	NOT PLACED	VR3201M1	4813977A48
R1018M1	NOT PLACED	VR3202M1	4813977A48
R1019M1	0613952R66	VR4000M1	4813977M13
R1020M1	0613952M66	VR4001M1	4813977A48
R1021M1	0613952Q73	VR4002M1	48012153001
R1022M1	NOT PLACED	VR4100M1	4813977A48
R1023M1	0613952R66	VR4101M1	4813977A48
R1024M1	NOT PLACED	VR4102M1	4813977A48
R1025M1	0613952Q73	VR4103M1	4813977A48
R1026M1	0613952R66	VR4104M1	48012049001
R1027M1	NOT PLACED	VR4105M1	4813977M13

Circuit Ref.	Motorola Solutions Part No.	Circuit Ref.	Motorola Solutions Part No.
R1028M1	0613952R66	VR4106M1	4813977A48
R1029M1	0613952R66	VR4107M1	4813977A48
R1030M1	NOT PLACED	VR4108M1	4813977A48
R1031M1	0613952R66	VR4109M1	4813977A50
R1033M1	0613952Q73	VR4110M1	4815040H01
R1034M1	0613952R17	VR4111M1	48012153001
R1035M1	NOT PLACED	-	-



NOTICE: The suffix "M1", "M2", and so on from the Circuit Ref. is removed from the schematics and overlays.

8.2.1.3
Controller R4 Schematic Diagrams

Figure 114: Controller Top Level Schematic Diagram

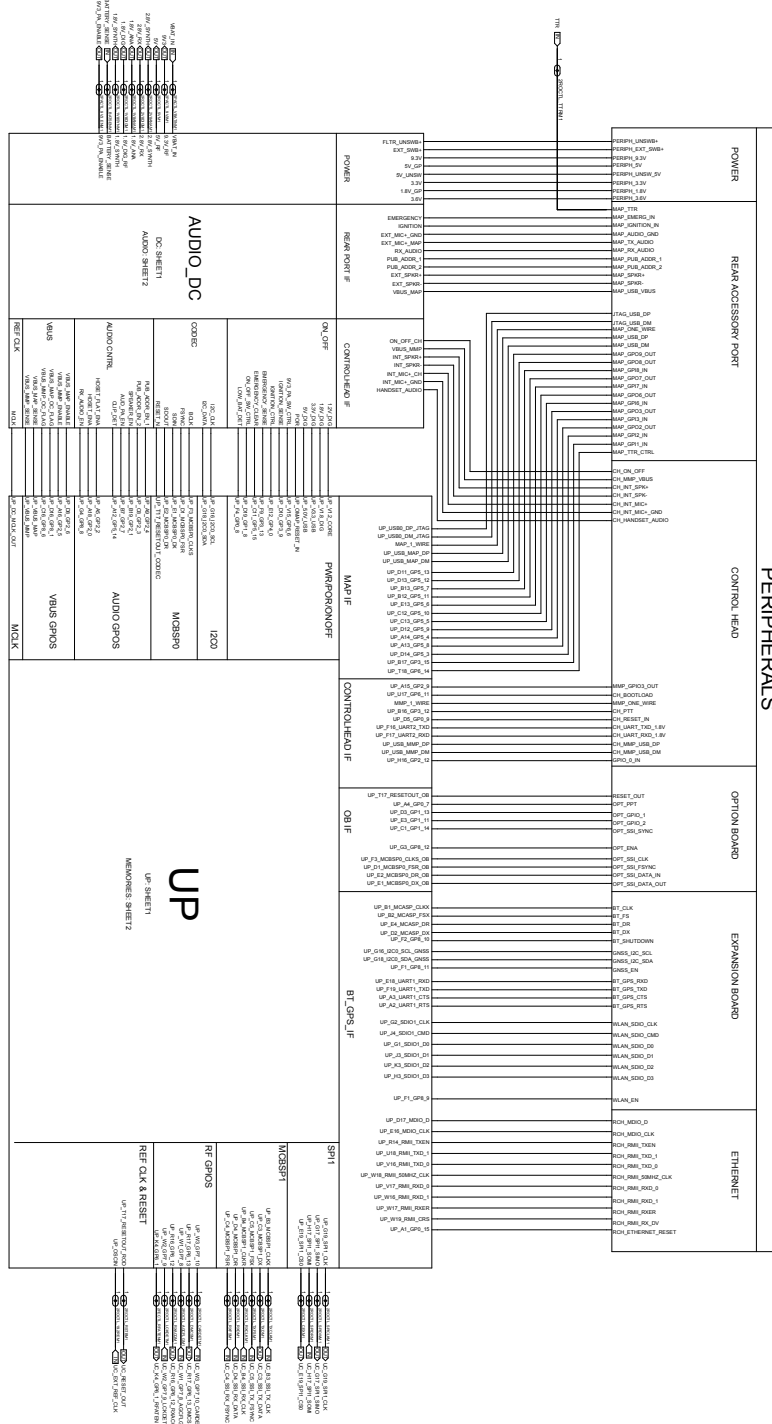

Figure 115: Controller DC Supply Schematic Diagram

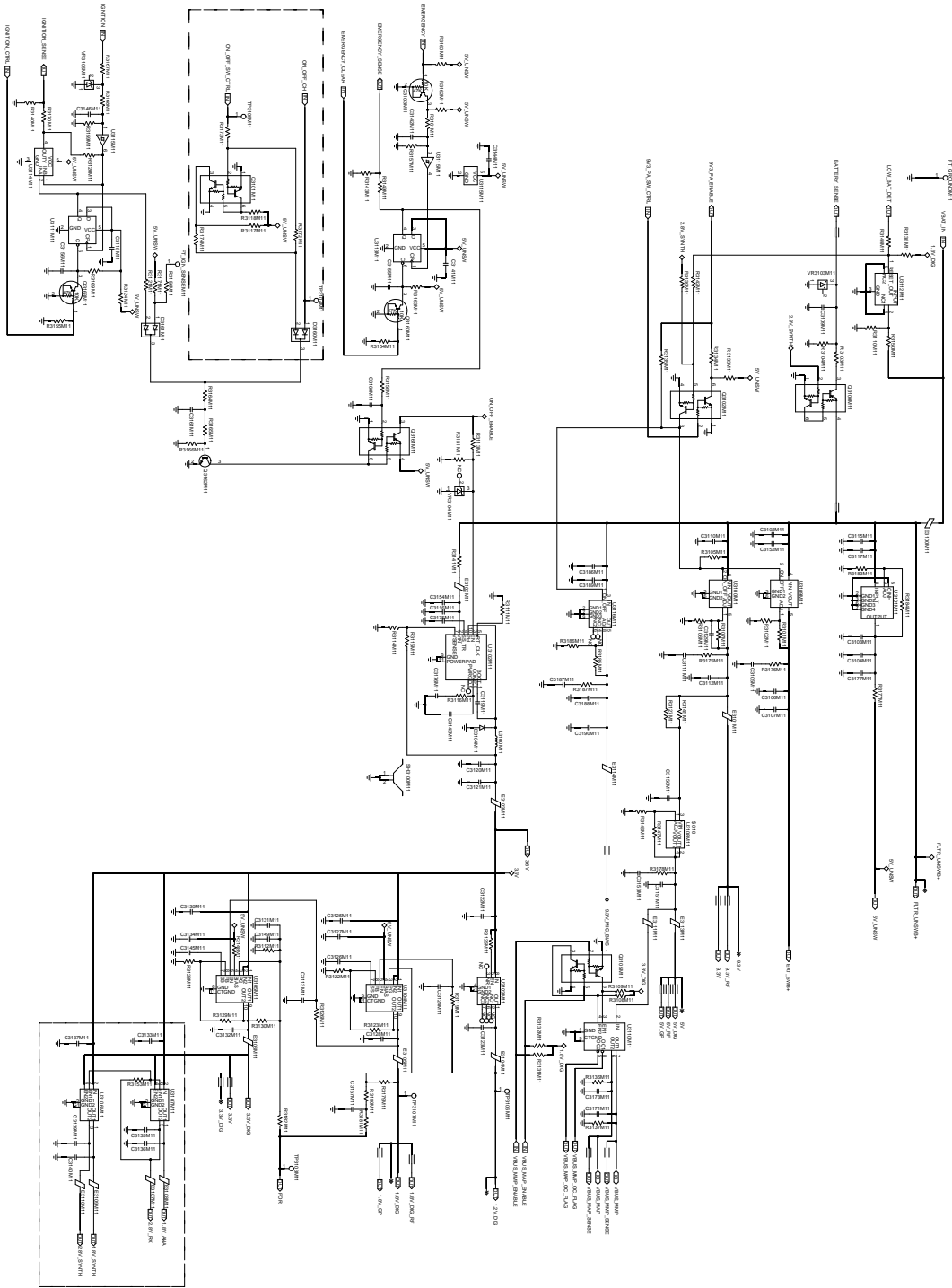

Figure 116: Controller Audio Schematic Diagram

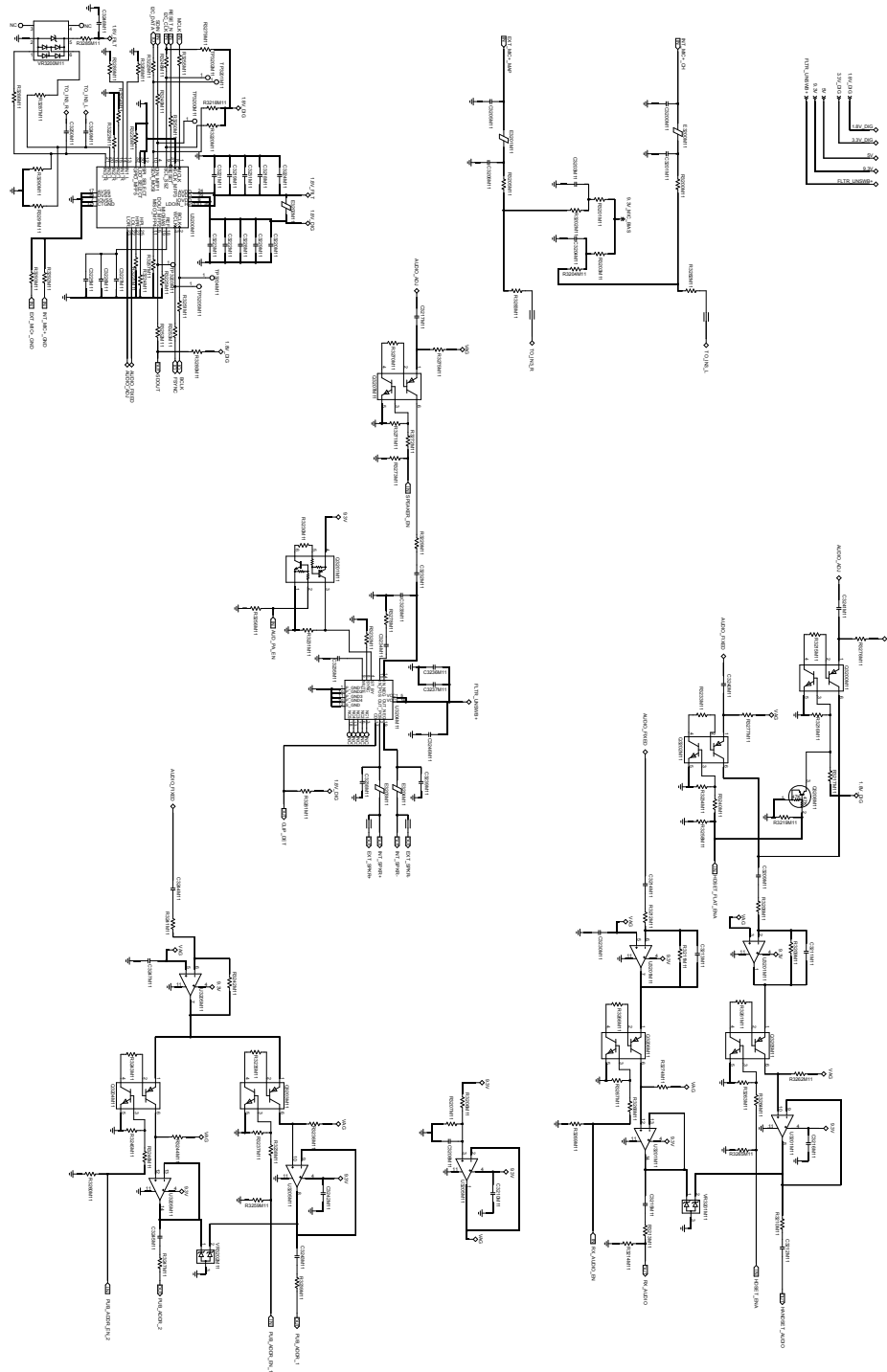

Figure 117: Controller Peripheral Schematic Diagram (Sheet 1 of 2)

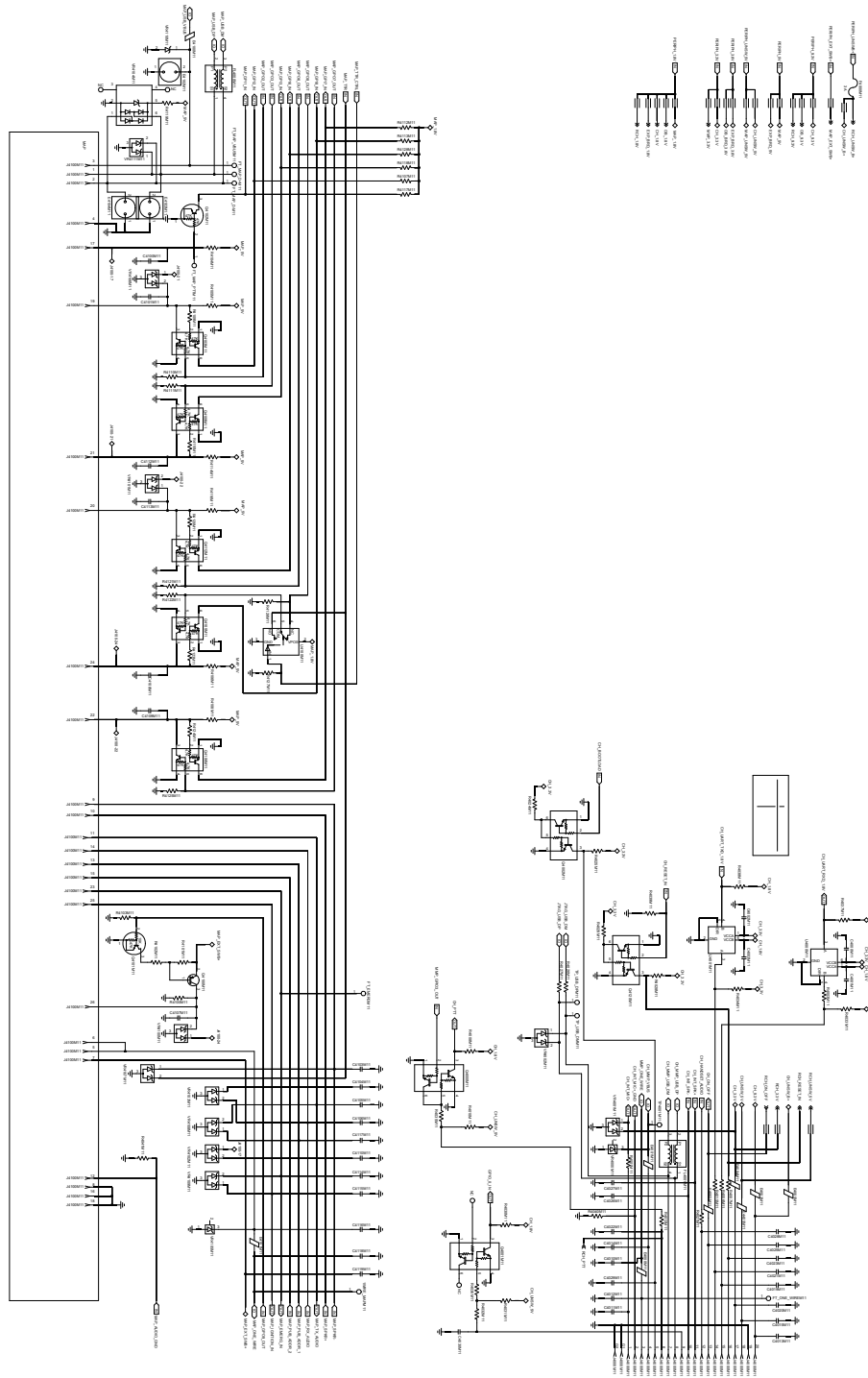

Figure 118: Controller Peripheral Schematic Diagram (Sheet 2 of 2)

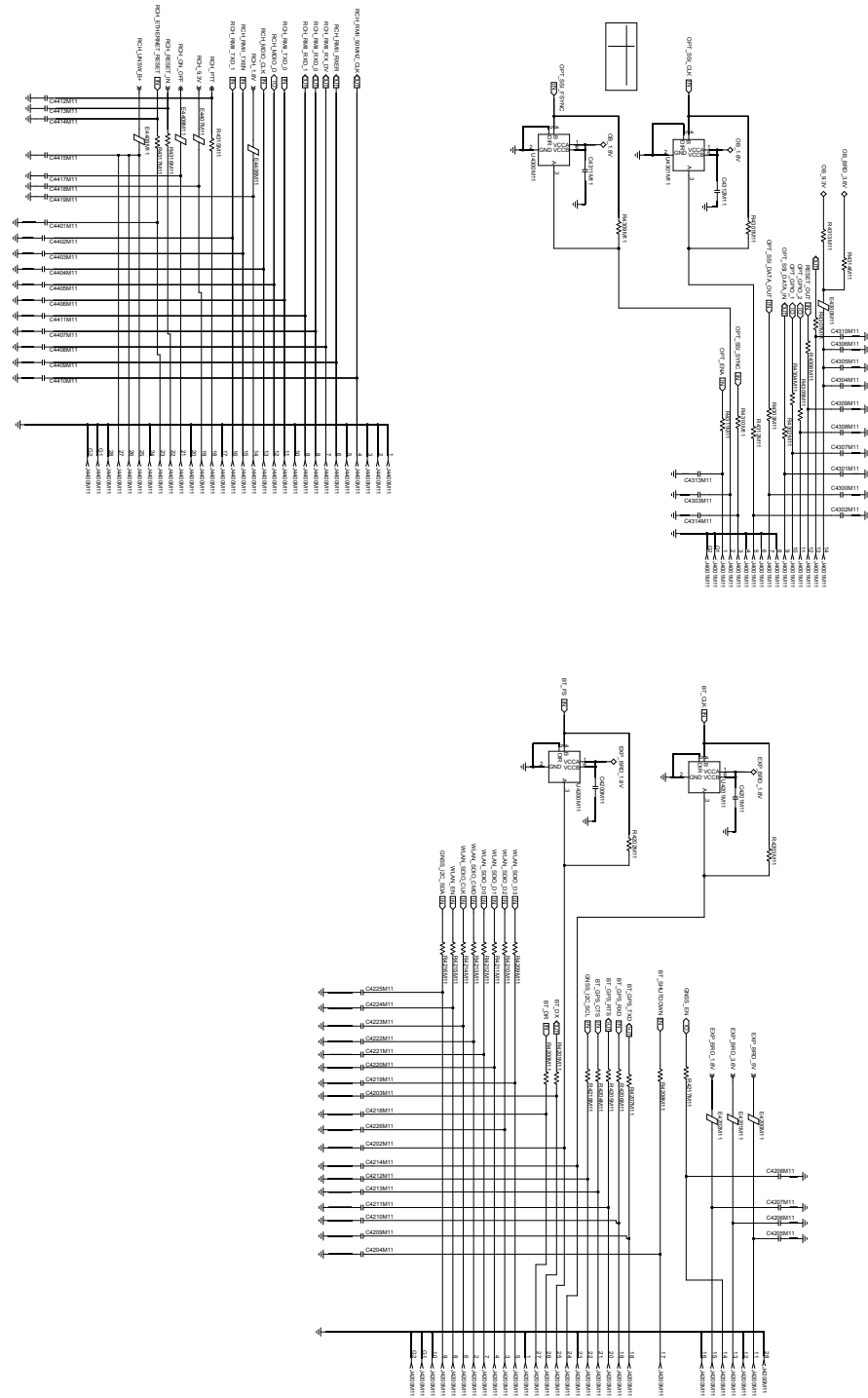

Figure 119: Controller Microprocessor Schematic Diagram

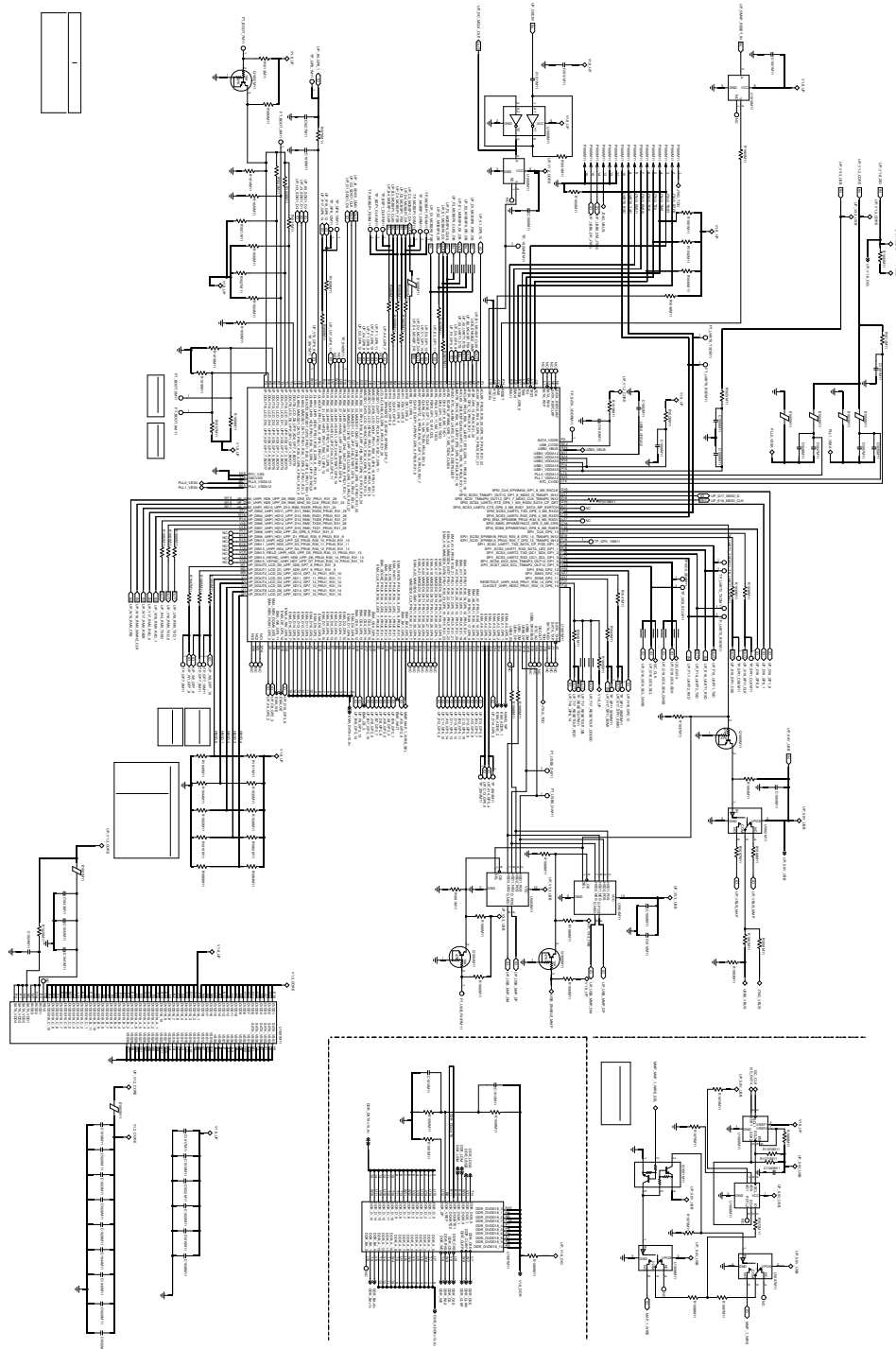
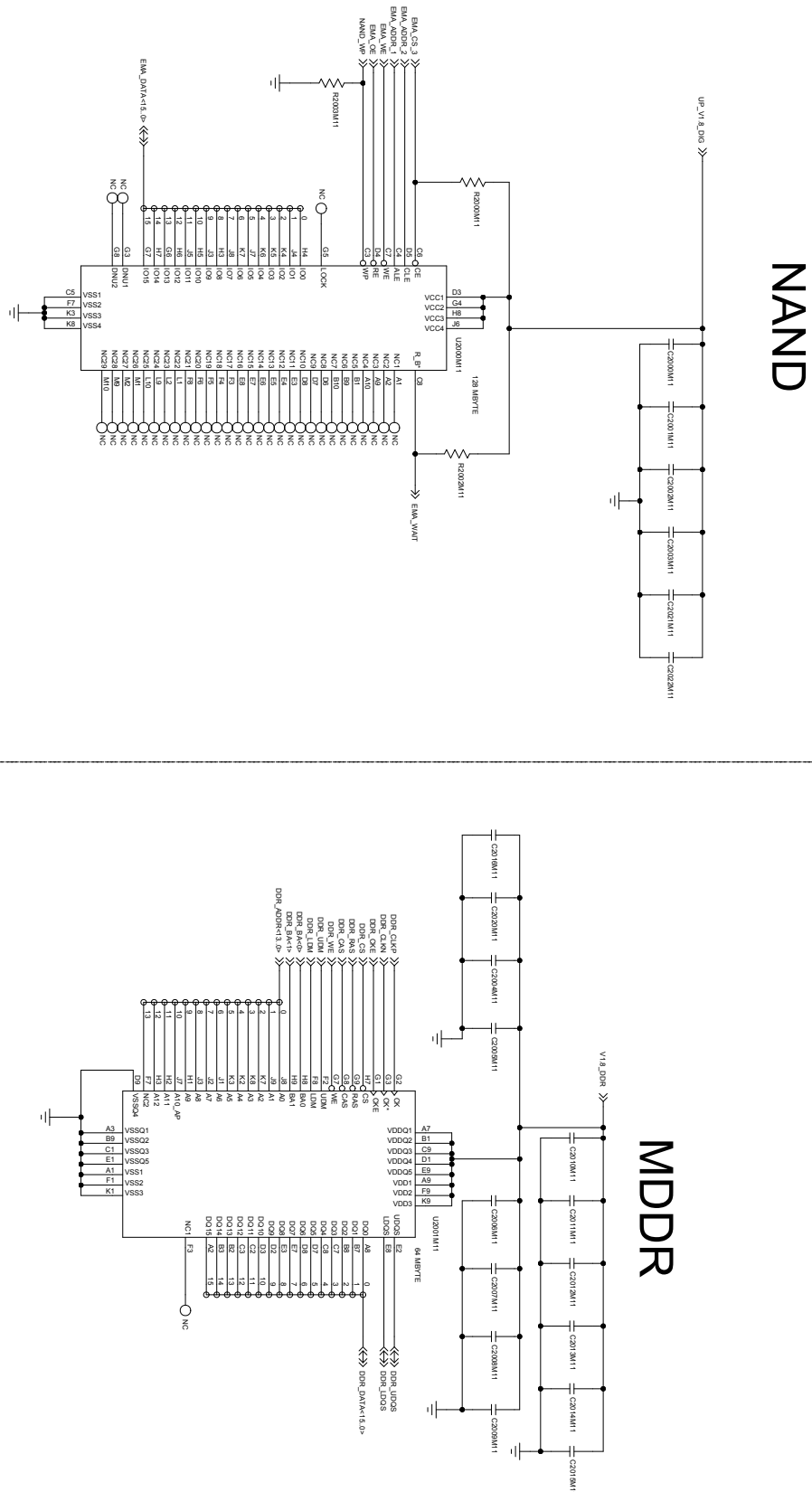

Figure 120: Controller Memories Schematic Diagram



8.2.1.4

Parts List for Controller R4

Table 15: Controller R4 Parts List

Circuit Ref.	Motorola Solutions Part No.	Circuit Ref.	Motorola Solutions Part No.
C1000M1	2113945Y02	R1035M1	NOT PLACED
C1001M1	2113945Y02	R1036M1	0613952M66
C1002M1	2113946K03	R1037M1	0613952M66
C1003M1	2113945Y02	R1038M1	0613952R66
C1004M1	2113945Y02	R1039M1	0613952R66
C1005M1	2113945Y02	R1040M1	0613952M66
C1006M1	2113945Y02	R1041M1	0613952R66
C1007M1	2113945Y02	R1042M1	0613952M66
C1008M1	2113946D05	R1043M1	0613952R66
C1009M1	2113945Y02	R1044M1	0613952M66
C1010M1	2113945Y02	R1045M1	0613952M66
C1011M1	2113945B02	R1046M1	0613952M66
C1012M1	2113945Y02	R1047M1	0613952R66
C1013M1	2113945Y02	R1048M1	0613952R66
C1014M1	2113945Y02	R1049M1	0613952Q73
C1015M1	2113945B02	R1050M1	0613952Q73
C1016M1	21667009166	R1051M1	0613952K68
C1017M1	21667009162	R1052M1	NOT PLACED
C1018M1	21667009162	R1053M1	0613952R66
C1019M1	21667009162	R1054M1	0613952M66
C1020M1	21667009162	R1056M1	0613952Q73
C1021M1	2113945Y02	R1057M1	0613952Q73
C1022M1	2113945Y02	R1058M1	0613952M66
C1023M1	2113945Y02	R1059M1	0613952R66
C1024M1	2113945Y02	R1060M1	0613952R66
C1025M1	2113945Y02	R1061M1	0613952R66
C1026M1	2113945Y02	R1062M1	NOT PLACED
C1027M1	NOT PLACED	R1063M1	NOT PLACED
C1028M1	2113945Y02	R1064M1	NOT PLACED
C1029M1	2113956B54	R1065M1	0613952R66
C1032M1	2113956B54	R1066M1	0613952M66
C1035M1	2113945B02	R1067M1	0613952M66

Circuit Ref.	Motorola Solutions Part No.	Circuit Ref.	Motorola Solutions Part No.
C1036M1	2113946D05	R1068M1	0613952R32
C1040M1	2113945Y02	R1069M1	NOT PLACED
C1041M1	2113945B02	R1070M1	0613952Q77
C1042M1	2113945Y02	R1071M1	0613952Q77
C1043M1	2113956B54	R1072M1	0613952Q49
C1044M1	2113945B02	R1073M1	0613952R01
C1045M1	2113945B02	R1074M1	0613952R66
C1047M1	2113945Y02	R1075M1	0613952R66
C1048M1	2113945B02	R1076M1	0613952R66
C2000M1	2113945Y02	R1077M1	0613952R66
C2001M1	2113945Y02	R1078M1	0613952R66
C2002M1	2113945B02	R1079M1	0613952R66
C2003M1	21667009162	R1080M1	0613952Q32
C2004M1	2113956B54	R1081M1	0613952Q32
C2005M1	2113946D05	R1082M1	0613952Q32
C2006M1	2113945Y02	R1084M1	0613952R66
C2007M1	2113945Y02	R1088M1	NOT PLACED
C2008M1	2113945B02	R1089M1	0613952R05
C2009M1	21667009162	R1090M1	0613952R05
C2010M1	2113945Y02	R1091M1	NOT PLACED
C2011M1	2113945Y02	R1092M1	0613952M43
C2012M1	2113945Y02	R1093M1	0613952Q73
C2013M1	2113945Y02	R1094M1	0613952M66
C2014M1	2113945B02	R1095M1	0613952Q34
C2015M1	21667009162	R1096M1	0613952Q34
C2016M1	2113956B54	R1097M1	0613952R66
C2020M1	2113956B54	R1098M1	0613952R66
C2021M1	2113956D59	R2000M1	0613952M66
C2022M1	2113956D59	R2002M1	0613952M66
C3102M1	21009337414	R2003M1	0613952M30
C3103M1	21667009166	R3101M1	0613952Z66
C3104M1	2113946F08	R3102M1	0613952M66
C3105M1	2113946J04	R3103M1	0613952N62
C3106M1	2113945C31	R3104M1	0613952M30
C3107M1	2113944C38	R3105M1	0613952R01

Circuit Ref.	Motorola Solutions Part No.	Circuit Ref.	Motorola Solutions Part No.
C3109M1	21667009166	R3106M1	0613952M09
C3110M1	2113944C06	R3107M1	0613952M85
C3111M1	2113946J04	R3108M1	0613952R17
C3112M1	2113945Y02	R3109M1	0613952R17
C3113M1	2113946S35	R3110M1	0613952N55
C3115M1	2113944C06	R3111M1	0613952R32
C3116M1	2113955D13	R3112M1	0613952P12
C3117M1	2113955D13	R3113M1	0613952R17
C3118M1	2113945Y02	R3114M1	0613952N01
C3119M1	2113945Y02	R3115M1	0613952Z63
C3120M1	2113956E60	R3116M1	0613952E83
C3121M1	2113956D58	R3117M1	0613952Q73
C3122M1	2113956A51	R3118M1	0613952R10
C3123M1	2113956A51	R3119M1	0613952Q73
C3124M1	2113946D07	R3120M1	0613952R66
C3125M1	2113946D05	R3121M1	0613952R66
C3126M1	2113944C06	R3122M1	0613952M43
C3127M1	2113946S35	R3123M1	0613952M54
C3128M1	2113946D05	R3124M1	0613952R66
C3129M1	2113945Y02	R3125M1	0613952R66
C3130M1	2113946D05	R3126M1	0613952R66
C3131M1	2113946A02	R3127M1	0613959Y09
C3132M1	2113946D05	R3128M1	0613952M10
C3133M1	2113946D05	R3129M1	0613952M58
C3134M1	2113946S35	R3130M1	0613952R25
C3135M1	2113956A51	R3131M1	0613952R01
C3136M1	21012095001	R3132M1	0613952R01
C3137M1	2113946D05	R3133M1	0613952R29
C3139M1	2113956A51	R3134M1	NOT PLACED
C3140M1	21012095001	R3135M1	0613952R66
C3141M1	2113945Y02	R3136M1	0613952R17
C3142M1	21012102001	R3137M1	0613952R17
C3143M1	21667009366	R3138M1	0613952R17
C3144M1	2113945Y02	R3139M1	0613952R66
C3145M1	2113944C06	R3140M1	0613952Q91

Circuit Ref.	Motorola Solutions Part No.	Circuit Ref.	Motorola Solutions Part No.
C3146M1	21012102001	R3141M1	0613959Y13
C3149M1	2113956A51	R3142M1	NOT PLACED
C3150M1	2113956C37	R3143M1	0613952Q91
C3151M1	2113945B02	R3144M1	0613952R66
C3152M1	2113944C06	R3145M1	0613959Y09
C3153M1	2113946J04	R3146M1	0613952M81
C3154M1	2113955D13	R3147M1	0613952M43
C3155M1	2113945Y02	R3148M1	0613952R66
C3156M1	2113945Y02	R3149M1	0613952R01
C3157M1	2113945Y02	R3150M1	0613952N62
C3160M1	2113945Y02	R3151M1	0613952R25
C3161M1	NOT PLACED	R3153M1	0613952R66
C3171M1	2113946D07	R3154M1	0613952Q89
C3173M1	2113946D07	R3155M1	0613952Q89
C3175M1	2113946A01	R3156M1	0613952R17
C3176M1	2113944C48	R3157M1	0613952R01
C3177M1	2113946F08	R3158M1	0613952R66
C3186M1	2113944C06	R3159M1	0613952R01
C3187M1	2113946J04	R3160M1	0613952Q89
C3188M1	2113945Y02	R3161M1	0613952Q73
C3189M1	2113956B21	R3162M1	0613952Q85
C3190M1	2113956B21	R3163M1	0613952R01
C3200M1	21667009166	R3164M1	0613952Q75
C3201M1	21667009166	R3165M1	0613952R01
C3203M1	2113955D37	R3166M1	0613952R17
C3204M1	2113955D37	R3167M1	0613952R01
C3205M1	21667009166	R3168M1	0613952Q73
C3206M1	21667009166	R3169M1	0613952R01
C3208M1	2113956C37	R3170M1	0613952R01
C3209M1	2113945Y02	R3171M1	NOT PLACED
C3210M1	2113945Y02	R3172M1	NOT PLACED
C3211M1	2113945A11	R3173M1	0613952R66
C3212M1	2113955D37	R3174M1	0613952R66
C3213M1	2113945A03	R3175M1	0689774Y02
C3214M1	2113955D37	R3176M1	0689774Y02

Circuit Ref.	Motorola Solutions Part No.	Circuit Ref.	Motorola Solutions Part No.
C3215M1	CA000819A01	R3177M1	0613952R66
C3216M1	2113945Y02	R3178M1	0615871H01
C3217M1	2113956B91	R3179M1	0613952R17
C3218M1	2113956A51	R3180M1	0613952R01
C3219M1	2113956A51	R3181M1	NOT PLACED
C3220M1	2113946F05	R3182M1	0613952R66
C3221M1	2113945Y02	R3183M1	0613952H92
C3222M1	2113956A51	R3184M1	0613952M30
C3223M1	2113945Y02	R3185M1	0613952M85
C3224M1	2113946F05	R3186M1	0613952M09
C3225M1	2113945Y02	R3187M1	0613952A01
C3226M1	NOT PLACED	R3200M1	0613952C44
C3227M1	2113946F05	R3201M1	0613952Q49
C3228M1	2113945Y02	R3202M1	0613952C44
C3229M1	2113956A51	R3203M1	0613952Q49
C3230M1	2113945Y02	R3204M1	0613952C44
C3231M1	2113945Y02	R3205M1	0613952C44
C3232M1	2113945Y02	R3206M1	0613952R01
C3233M1	2113945A09	R3207M1	0613952R01
C3234M1	2113945Y02	R3208M1	0613952N30
C3235M1	21012102001	R3209M1	0613952R03
C3236M1	2113945C31	R3210M1	0613952Q67
C3237M1	21009337414	R3211M1	0613952N30
C3238M1	2113945A09	R3212M1	0613952R03
C3239M1	2113945A09	R3213M1	0613952Q42
C3240M1	2113956B91	R3214M1	0613952J25
C3241M1	2113956B91	R3215M1	0613952R01
C3242M1	2113945C31	R3216M1	0613952R17
C3243M1	2113955D37	R3217M1	0613952R01
C3244M1	2113956B91	R3218M1	0613952R01
C3245M1	2113955D37	R3219M1	NOT PLACED
C3246M1	2113945C31	R3220M1	0613952R01
C3247M1	2113945Y02	R3221M1	NOT PLACED
C3248M1	2113945Y02	R3222M1	0613952R01
C3249M1	2113956B91	R3223M1	0613952R66

Circuit Ref.	Motorola Solutions Part No.	Circuit Ref.	Motorola Solutions Part No.
C3250M1	CA000308A01	R3224M1	NOT PLACED
C4000M1	2113945Y02	R3225M1	NOT PLACED
C4001M1	2113945Y02	R3226M1	0613952R01
C4002M1	2113945Y02	R3229M1	0613952R01
C4003M1	2113945Y02	R3230M1	0613952R10
C4010M1	21667009166	R3231M1	0613952R10
C4011M1	21667009166	R3232M1	0613952R10
C4012M1	21667009166	R3233M1	0613952R01
C4013M1	21667009166	R3234M1	NOT PLACED
C4014M1	21667009166	R3235M1	0613952R01
C4015M1	21667009166	R3236M1	0613952R10
C4019M1	21667009166	R3237M1	NOT PLACED
C4020M1	21667009166	R3238M1	0613952R01
C4021M1	21667009166	R3239M1	0613952Q49
C4022M1	21667009166	R3240M1	0613952R01
C4023M1	21667009166	R3241M1	0613952M54
C4025M1	21667009166	R3242M1	0613952R01
C4026M1	21667009166	R3243M1	0613952R01
C4027M1	21667009166	R3244M1	0613952R10
C4028M1	21667009166	R3245M1	NOT PLACED
C4029M1	21667009166	R3246M1	0613952R01
C4030M1	21667009166	R3247M1	0613952Q49
C4100M1	21667009166	R3248M1	0613952R66
C4101M1	21667009166	R3249M1	0613952R66
C4103M1	21667009166	R3250M1	0613952R66
C4104M1	21667009166	R3251M1	0613952R66
C4105M1	21667009166	R3252M1	0613952R66
C4106M1	21667009166	R3253M1	0613952R66
C4107M1	21667009166	R3254M1	0613952R01
C4108M1	21667009166	R3255M1	0613952R66
C4109M1	21667009166	R3256M1	0613952M66
C4110M1	21667009166	R3257M1	0613952R01
C4112M1	21667009166	R3258M1	0613952M66
C4113M1	21667009166	R3259M1	0613952M66
C4114M1	21667009166	R3260M1	0613952M66

Circuit Ref.	Motorola Solutions Part No.	Circuit Ref.	Motorola Solutions Part No.
C4115M1	21667009166	R3261M1	0613952R01
C4116M1	21667009166	R3262M1	0613952R10
C4117M1	21667009166	R3263M1	NOT PLACED
C4118M1	21667009166	R3264M1	0613952R01
C4119M1	21667009166	R3265M1	0613952M66
C4200M1	2113945Y02	R3266M1	0613952R01
C4201M1	2113945Y02	R3267M1	NOT PLACED
C4202M1	21667009166	R3268M1	0613952R01
C4203M1	21667009166	R3269M1	0613952M66
C4204M1	NOT PLACED	R3270M1	0613952R01
C4205M1	21667009166	R3271M1	NOT PLACED
C4206M1	21667009166	R3272M1	0613952R01
C4207M1	21667009166	R3273M1	0613952M66
C4208M1	21667009166	R3274M1	0613952R10
C4209M1	21667009166	R3275M1	0613952R10
C4210M1	21667009166	R3276M1	0613952R10
C4211M1	21667009166	R3277M1	0613952R10
C4212M1	21667009166	R3278M1	0613952R01
C4213M1	21667009166	R3279M1	NOT PLACED
C4214M1	21667009166	R3280M1	NOT PLACED
C4218M1	21667009166	R3281M1	NOT PLACED
C4219M1	21667009339	R3282M1	0613952R66
C4220M1	21667009339	R3283M1	0613952R66
C4221M1	21667009339	R3285M1	0613952R01
C4222M1	21667009339	R3286M1	0613952R66
C4223M1	21667009339	R3287M1	0613952R66
C4224M1	21667009166	R3288M1	0613952R01
C4225M1	21667009166	R3289M1	0613952R01
C4226M1	21667009339	R3290M1	NOT PLACED
C4300M1	NOT PLACED	R3291M1	NOT PLACED
C4301M1	NOT PLACED	R3292M1	0613952R66
C4302M1	NOT PLACED	R3293M1	0613952R66
C4303M1	NOT PLACED	R4001M1	0613952R66
C4304M1	21667009166	R4003M1	0613952R66
C4305M1	21667009376	R4006M1	0613952Q37

Circuit Ref.	Motorola Solutions Part No.	Circuit Ref.	Motorola Solutions Part No.
C4306M1	21667009381	R4007M1	0613952Q37
C4307M1	NOT PLACED	R4008M1	0613952R01
C4308M1	NOT PLACED	R4010M1	0613952R01
C4309M1	21667009166	R4013M1	0613952Q42
C4310M1	21667009166	R4015M1	0613952Q37
C4311M1	2113945Y02	R4021M1	0613952R66
C4312M1	2113945Y02	R4024M1	0613952R01
C4313M1	21667009166	R4025M1	0613952R01
C4314M1	NOT PLACED	R4026M1	0613952R66
C4401M1	NOT PLACED	R4027M1	0613952R66
C4402M1	NOT PLACED	R4028M1	0613952R01
C4403M1	NOT PLACED	R4029M1	0613952R01
C4404M1	NOT PLACED	R4030M1	0613952R01
C4405M1	NOT PLACED	R4031M1	0613952R01
C4406M1	NOT PLACED	R4032M1	0613952R66
C4407M1	NOT PLACED	R4033M1	0613952M43
C4408M1	NOT PLACED	R4034M1	0613952M43
C4409M1	NOT PLACED	R4035M1	0613952R66
C4410M1	NOT PLACED	R4036M1	0613952R66
C4411M1	NOT PLACED	R4037M1	0613952R01
C4412M1	21667009166	R4038M1	0613952R01
C4413M1	21667009166	R4039M1	NOT PLACED
C4414M1	21667009166	R4040M1	NOT PLACED
C4415M1	21667009166	R4041M1	NOT PLACED
C4417M1	21667009166	R4100M1	0613952R01
C4418M1	21667009166	R4101M1	0613952Q77
C4419M1	21667009166	R4102M1	0613958H83
D3104M1	4885489Y01	R4103M1	0613952Q85
D3160M1	4813978C02	R4104M1	0613952Q89
D3161M1	4813978C02	R4105M1	0613952Q89
E1000M1	7686949J15	R4106M1	0613952Q89
E1001M1	7686949J15	R4107M1	0613952R01
E1002M1	7686949J15	R4108M1	0613952Q89
E1003M1	7686949J15	R4109M1	0613952N58
E1004M1	7686949J15	R4110M1	0613952Q85

Circuit Ref.	Motorola Solutions Part No.	Circuit Ref.	Motorola Solutions Part No.
E1005M1	7686949J15	R4111M1	0613952Q85
E1006M1	7685268E01	R4112M1	0613952R01
E3100M1	24012102001	R4113M1	0613952R01
E3101M1	2485410Y02	R4114M1	0613952Q89
E3102M1	2485410Y02	R4115M1	0613952N58
E3103M1	2485410Y02	R4116M1	0613952Q89
E3104M1	7686949J22	R4117M1	0613952R01
E3105M1	7686949J22	R4118M1	0613952R01
E3106M1	7686949J22	R4119M1	0613952R01
E3107M1	7686949J22	R4120M1	0613952N58
E3108M1	7686949J22	R4121M1	0613952Q85
E3109M1	7686949J22	R4122M1	0613952Q85
E3110M1	7686949J22	R4123M1	0613952N58
E3111M1	7686949J22	R4124M1	0613952N58
E3113M1	7686949J22	R4125M1	0613952Q85
E3114M1	2485410Y02	R4126M1	0613952Q85
E3200M1	24012102001	R4127M1	0613952Q85
E3201M1	24012102001	R4128M1	0613952R01
E3202M1	24012107027	R4200M1	0613952R66
E3203M1	24012102001	R4201M1	0613952R66
E3204M1	24012102001	R4202M1	0613952R66
E4000M1	24012107027	R4203M1	0613952R66
E4001M1	7688697V05	R4204M1	0613952R66
E4002M1	24012107027	R4205M1	0613952R66
E4003M1	NOT PLACED	R4206M1	0613952R66
E4004M1	24012102001	R4207M1	0613952R66
E4005M1	2485410Y02	R4208M1	0613952R66
E4100M1	7686949J14	R4209M1	HZ000375A01
E4101M1	24012107027	R4210M1	HZ000375A01
E4102M1	NOT PLACED	R4211M1	HZ000375A01
E4103M1	NOT PLACED	R4212M1	HZ000375A01
E4104M1	NOT PLACED	R4213M1	HZ000375A01
E4200M1	24012107027	R4214M1	HZ000375A01
E4201M1	24012107027	R4215M1	0613952R66
E4202M1	24012107027	R4216M1	0613952R66

Circuit Ref.	Motorola Solutions Part No.	Circuit Ref.	Motorola Solutions Part No.
E4300M1	24012107027	R4217M1	0613952R66
E4405M1	24012107027	R4218M1	0613952R66
E4406M1	7686949J22	R4301M1	NOT PLACED
E4407M1	7686949J22	R4302M1	0613952R66
E4408M1	24012107027	R4303M1	0613952R66
E4409M1	24012102001	R4304M1	0613952R66
F4000M1	65012019001	R4305M1	0613952R66
FL4000M1	24012038001	R4306M1	0613952R66
FL4001M1	24012038001	R4307M1	0613952R66
J4000M1	0915767H01	R4309M1	NOT PLACED
J4001M1	0915556H01	R4310M1	0613952R66
J4100M1	0916017H01	R4311M1	0613952R66
J4200M1	9012053001	R4312M1	0613952R66
J4400M1	9012053001	R4313M1	NOT PLACED
L3100M1	24012091002	R4314M1	0613952R66
P1000M1	2887818K02	R4315M1	0613952R66
Q1000M1	4815263H01	R4316M1	0613952R66
Q1001M1	4815272H01	R4317M1	0613952R66
Q1002M1	4815261H01	SH3100M1	NOT PLACED
Q1004M1	4815261H01	U1000M1	5171320H01
Q1005M1	4815261H01	U1001M1	51012295001
Q3100M1	4815272H01	U1002M1	5189139P01
Q3101M1	4809939C47	U1003M1	5175772B56
Q3102M1	4809939C47	U1004M1	5175772B56
Q3103M1	48009494001	U1005M1	5164852H47
Q3105M1	4809939C47	U1006M1	5185493Y01
Q3160M1	48009494001	U1007M1	5189139P01
Q3161M1	4815272H01	U1008M1	5189139P01
Q3162M1	4813973M07	U1009M1	5115001H02
Q3163M1	48009494001	U1010M1	5171320H01
Q3200M1	4815270H01	U2000M1	51012239003
Q3201M1	4815272H01	U2001M1	MM000129A01
Q3202M1	4815270H01	U3100M1	0104039J08
Q3203M1	4815270H01	U3101M1	5114014A01
Q3204M1	4815270H01	U3102M1	51012069001

Circuit Ref.	Motorola Solutions Part No.	Circuit Ref.	Motorola Solutions Part No.
Q3205M1	4815270H01	U3103M1	51012142001
Q3206M1	4815270H01	U3104M1	5171590Y73
Q3207M1	4815270H01	U3105M1	5114610F01
Q3208M1	4815263H01	U3106M1	51012140001
Q4000M1	4809939C47	U3107M1	51012140001
Q4001M1	4809939C47	U3108M1	51012138001
Q4002M1	4809939C47	U3109M1	5164015H94
Q4100M1	4816023H01	U3110M1	51012208001
Q4101M1	4815261H01	U3111M1	5188690V02
Q4102M1	4815263H01	U3112M1	5114004A35
Q4103M1	48012271001	U3113M1	5188690V02
Q4105M1	48012271001	U3114M1	NOT PLACED
Q4106M1	48012271001	U3115M1	5185937Y01
Q4109M1	48012271001	U3116M1	5171774H01
Q4112M1	48012271001	U3200M1	51009415001
Q4120M1	4809939C47	U3201M1	5114016A18
R1000M1	0613952R66	U3204M1	51009509001
R1001M1	0613952M66	U3205M1	5114016A18
R1002M1	0613952R66	U4000M1	51012082001
R1003M1	0613952R66	U4001M1	51012082001
R1004M1	0613952R66	U4100M1	5189139P01
R1005M1	0613952M66	U4200M1	NOT PLACED
R1007M1	0613952R66	U4201M1	NOT PLACED
R1008M1	0613952R66	U4300M1	51012082001
R1009M1	0613952R66	U4301M1	51012082001
R1010M1	NOT PLACED	VR3103M1	48012095001
R1011M1	NOT PLACED	VR3104M1	48012095002
R1012M1	0613952R66	VR3105M1	4813977M10
R1013M1	0613952M66	VR3200M1	48012049001
R1014M1	NOT PLACED	VR3201M1	4813977A48
R1016M1	NOT PLACED	VR3202M1	4813977A48
R1018M1	NOT PLACED	VR4000M1	4813977M13
R1019M1	0613952R66	VR4001M1	4813977A48
R1020M1	0613952M66	VR4002M1	48012153001
R1021M1	0613952Q73	VR4100M1	4813977A48

Circuit Ref.	Motorola Solutions Part No.	Circuit Ref.	Motorola Solutions Part No.
R1022M1	NOT PLACED	VR4101M1	4813977A48
R1023M1	0613952R66	VR4102M1	4813977A48
R1024M1	NOT PLACED	VR4103M1	4813977A48
R1025M1	0613952Q73	VR4104M1	48012049001
R1026M1	0613952R66	VR4105M1	4813977M13
R1027M1	NOT PLACED	VR4106M1	4813977A48
R1028M1	0613952R66	VR4107M1	4813977A48
R1029M1	0613952R66	VR4108M1	4813977A48
R1030M1	NOT PLACED	VR4109M1	4813977A50
R1031M1	0613952R66	VR4110M1	4815040H01
R1033M1	0613952Q73	VR4111M1	48012153001
R1034M1	0613952R17	-	-



NOTICE: The suffix "M1", "M2", and so on from the Circuit Ref. is removed from the schematics and overlays.

8.2.1.5
Controller R5 Schematic Diagrams

Figure 121: Controller Top Level Schematic Diagram

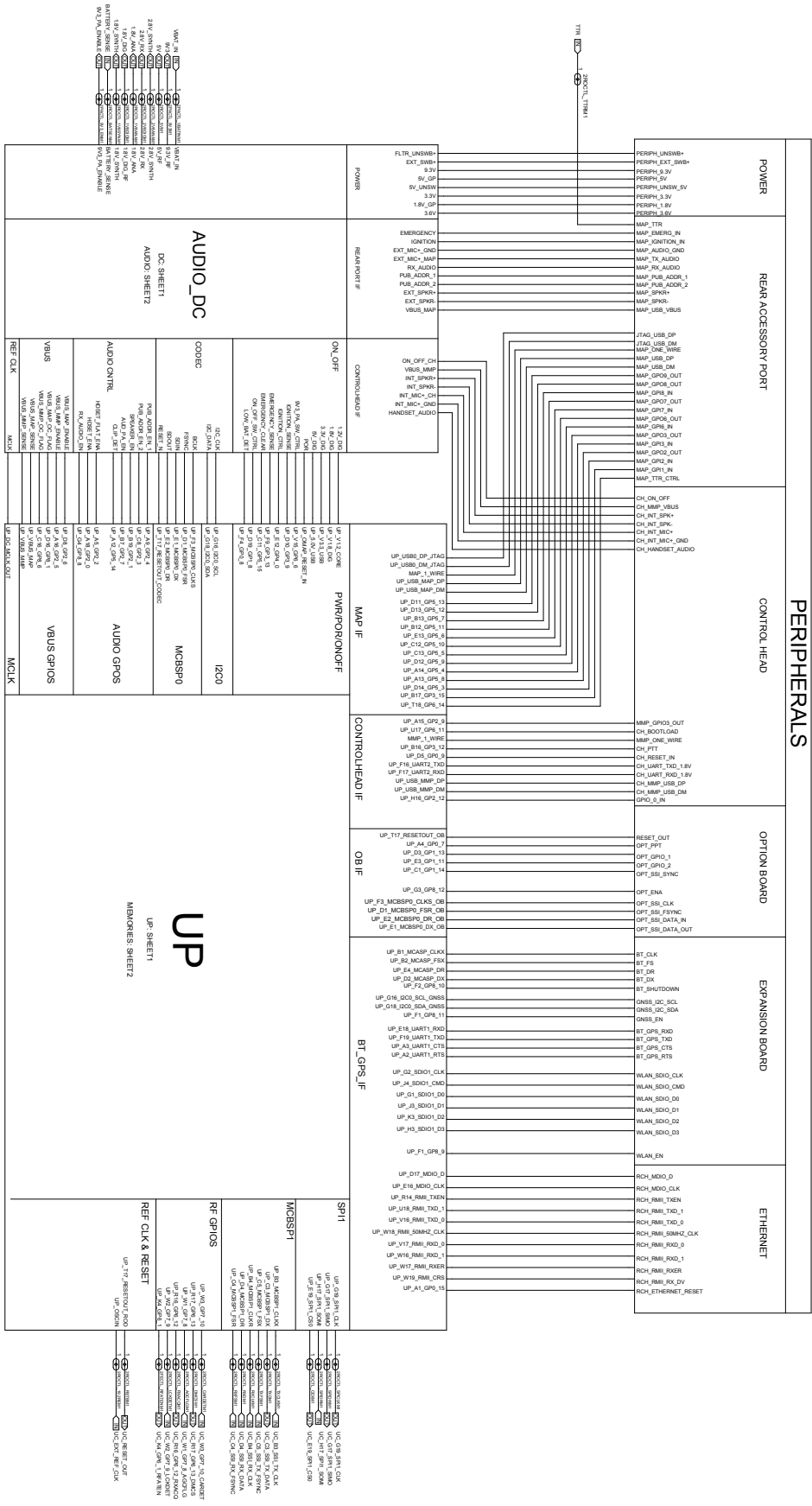

Figure 122: Controller DC Supply Schematic Diagram

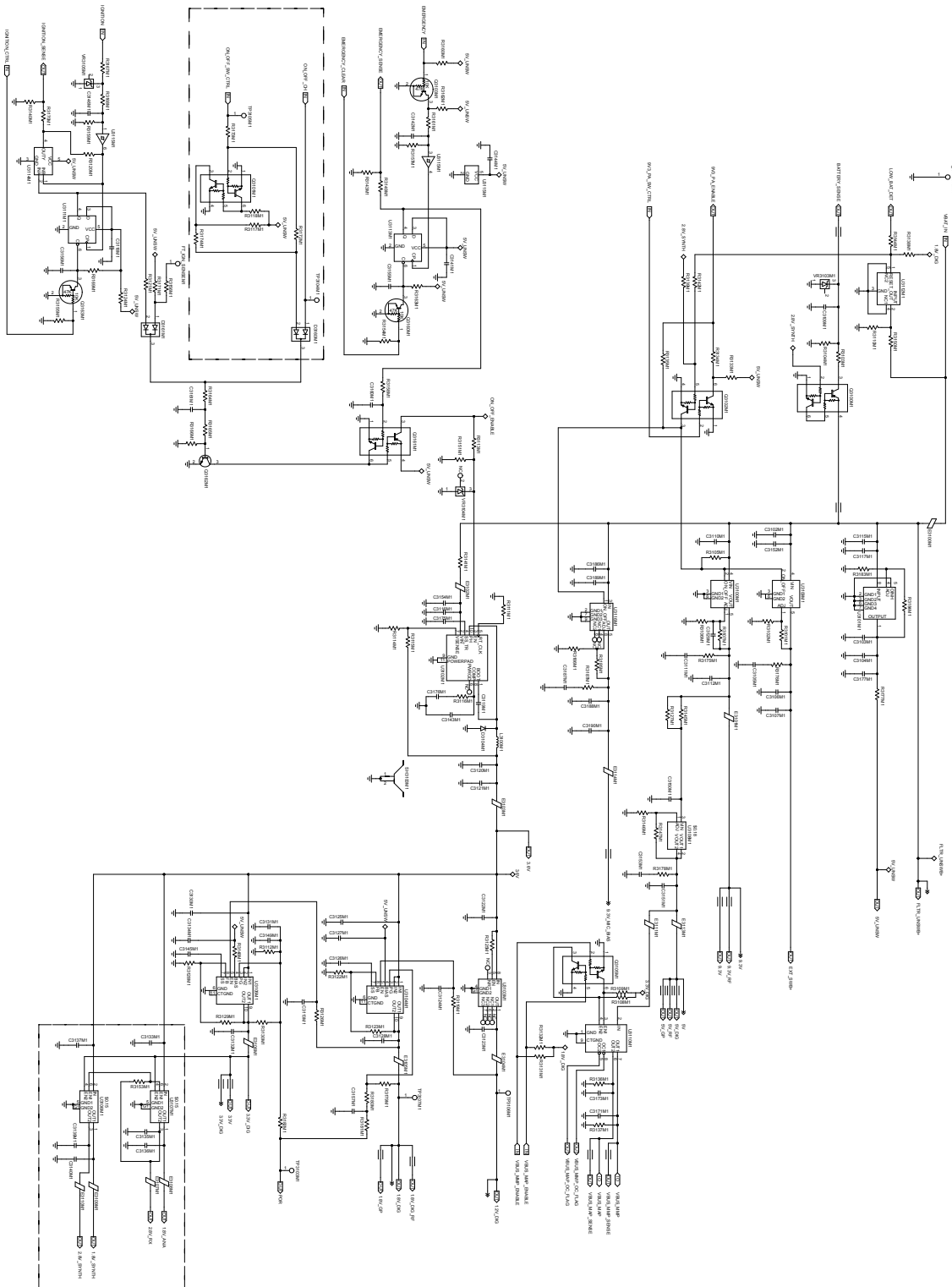

Figure 123: Controller Audio Schematic Diagram

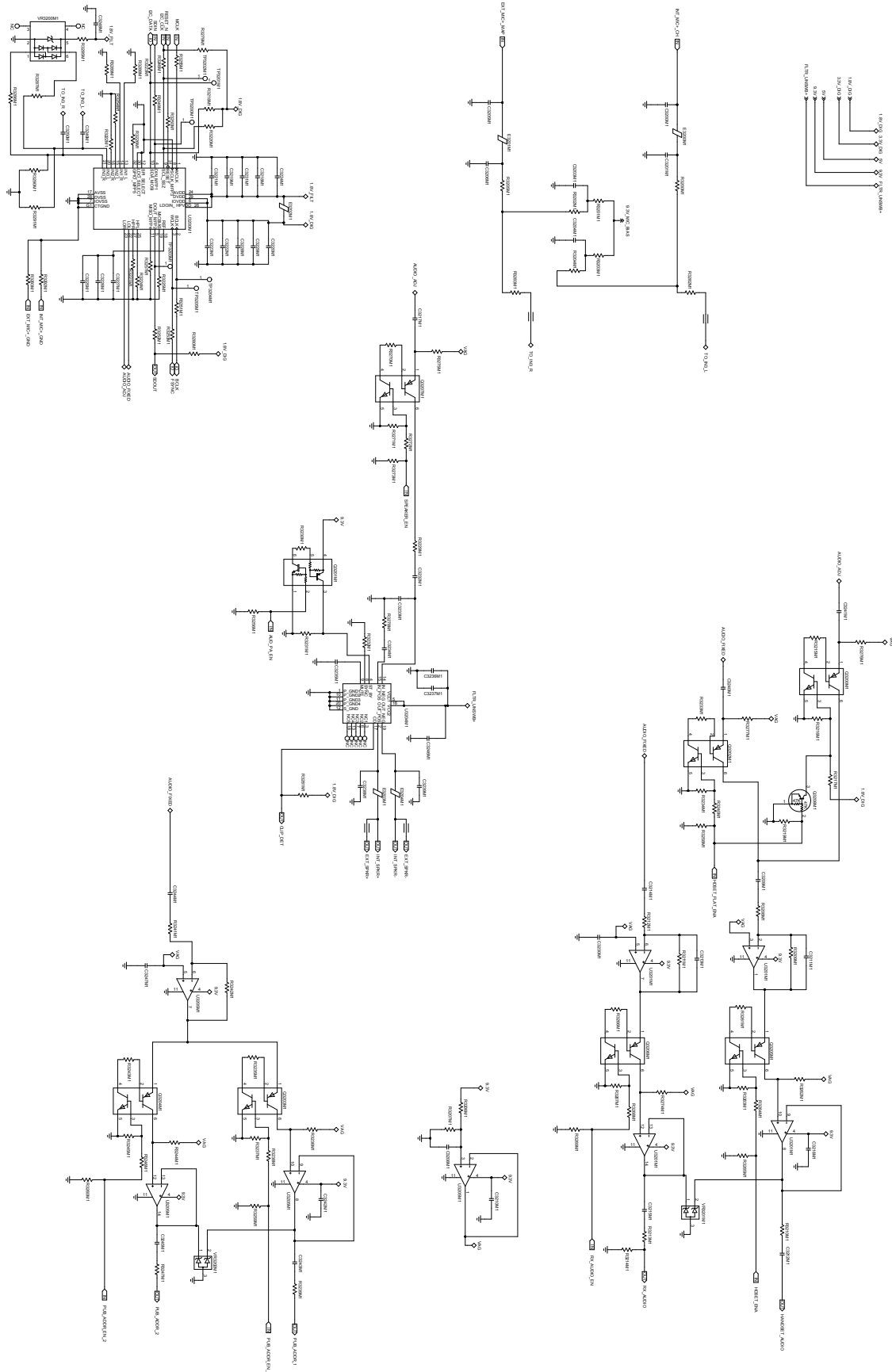

Figure 124: Controller Peripheral Schematic Diagram (Sheet 1 of 2)

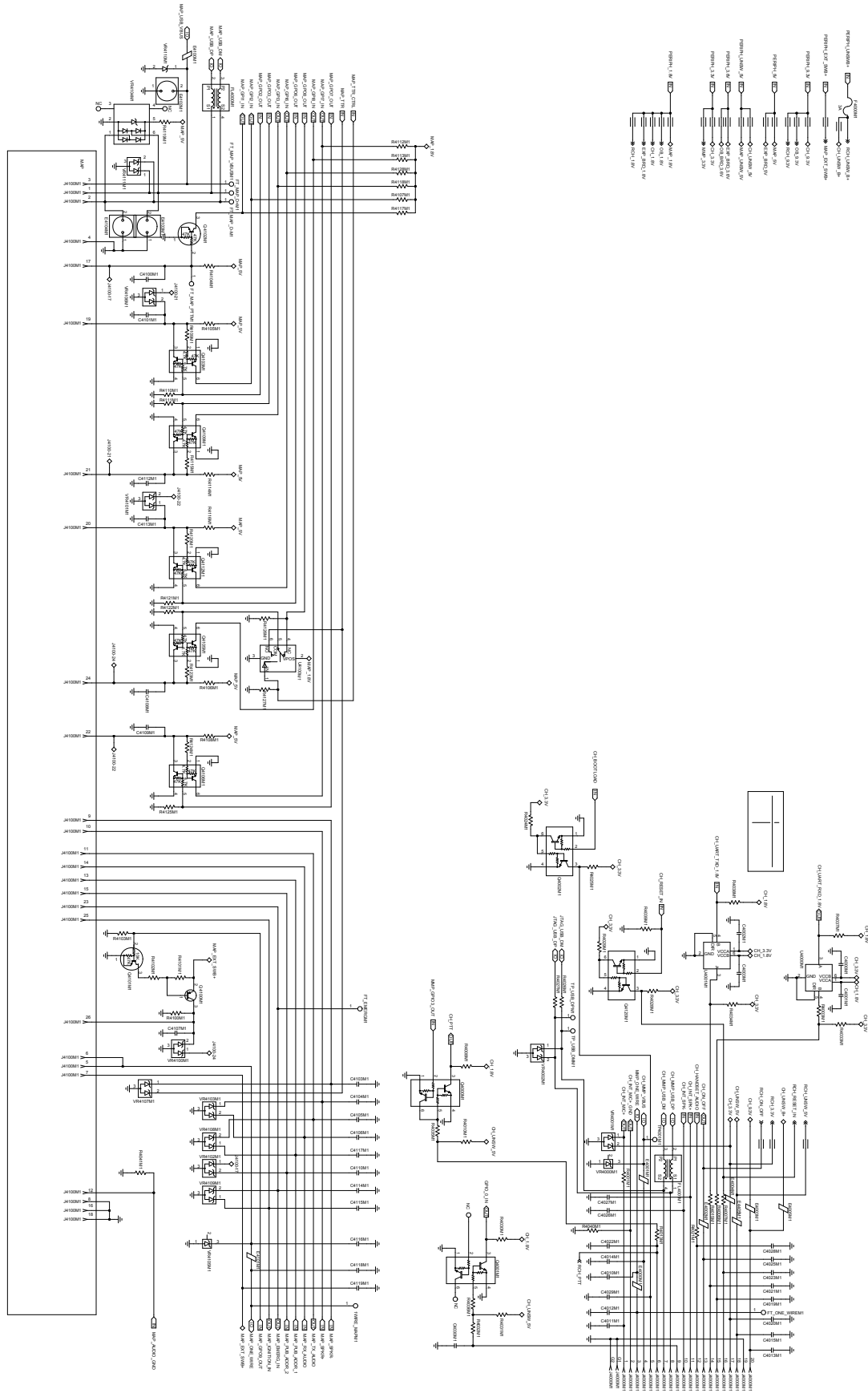

Figure 126: Controller Microprocessor Schematic Diagram

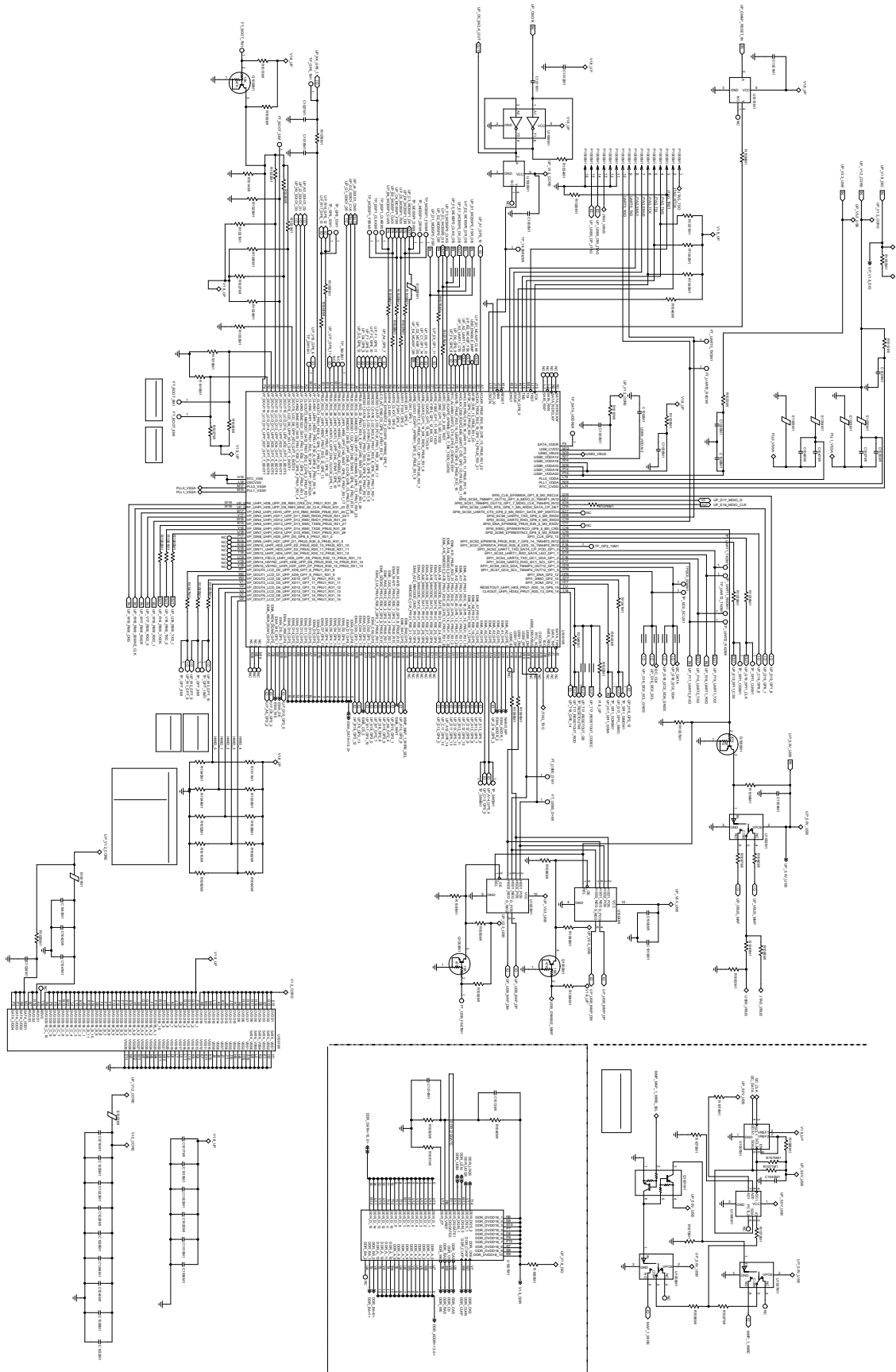
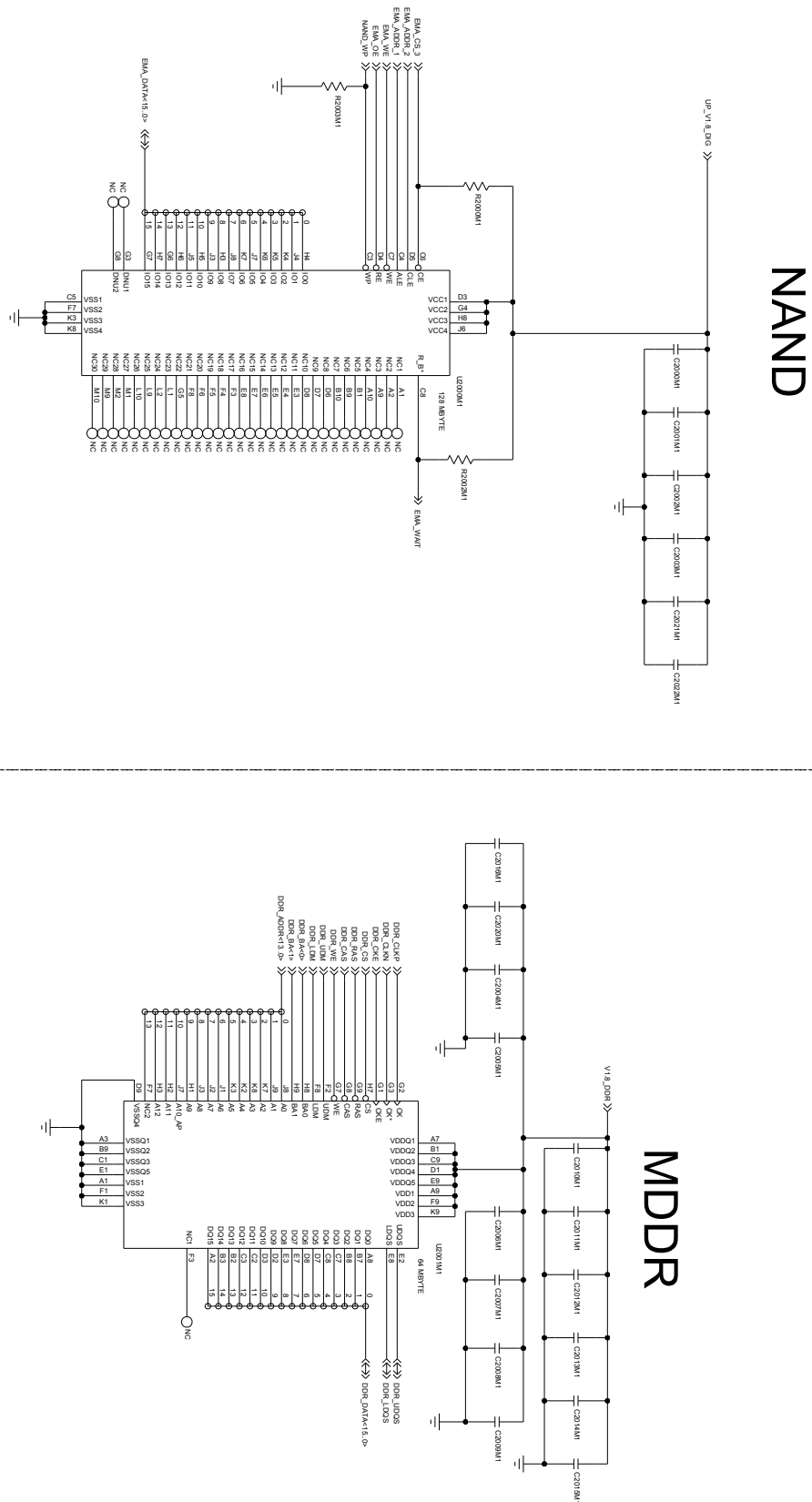

Figure 127: Controller Memories Schematic Diagram



8.2.1.6

Parts List for Controller R5

Table 16: Controller R5 Parts List

Circuit Ref.	Motorola Solutions Part No.	Circuit Ref.	Motorola Solutions Part No.
C1000M1	2113945Y02	R1035M1	NOT PLACED
C1001M1	2113945Y02	R1036M1	0613952M66
C1002M1	CA000098A01	R1037M1	0613952M66
C1003M1	2113945Y02	R1038M1	0613952R66
C1004M1	2113945Y02	R1039M1	0613952R66
C1005M1	2113945Y02	R1040M1	0613952M66
C1006M1	2113945Y02	R1041M1	0613952R66
C1007M1	2113945Y02	R1042M1	0613952M66
C1008M1	2113946D05	R1043M1	0613952R66
C1009M1	2113945Y02	R1044M1	0613952M66
C1010M1	2113945Y02	R1045M1	0613952M66
C1011M1	2113945B02	R1046M1	0613952M66
C1012M1	2113945Y02	R1047M1	0613952R66
C1013M1	2113945Y02	R1048M1	0613952R66
C1014M1	2113945Y02	R1049M1	0613952Q73
C1015M1	2113945B02	R1050M1	0613952Q73
C1016M1	21667009166	R1051M1	0613952K68
C1017M1	21667009162	R1052M1	NOT PLACED
C1018M1	21667009162	R1053M1	0613952R66
C1019M1	21667009162	R1054M1	0613952M66
C1020M1	21667009162	R1056M1	0613952Q73
C1021M1	2113945Y02	R1057M1	0613952Q73
C1022M1	2113945Y02	R1058M1	0613952M66
C1023M1	2113945Y02	R1059M1	0613952R66
C1024M1	2113945Y02	R1060M1	0613952R66
C1025M1	2113945Y02	R1061M1	0613952R66
C1026M1	2113945Y02	R1062M1	NOT PLACED
C1027M1	NOT PLACED	R1063M1	NOT PLACED
C1028M1	2113945Y02	R1064M1	NOT PLACED
C1029M1	2113956B54	R1065M1	0613952R66
C1032M1	2113956B54	R1066M1	0613952M66
C1035M1	2113945B02	R1067M1	0613952M66

Circuit Ref.	Motorola Solutions Part No.	Circuit Ref.	Motorola Solutions Part No.
C1036M1	2113946D05	R1068M1	0613952R32
C1040M1	2113945Y02	R1069M1	NOT PLACED
C1041M1	2113945B02	R1070M1	0613952Q77
C1042M1	2113945Y02	R1071M1	0613952Q77
C1043M1	2113956B54	R1072M1	0613952Q49
C1044M1	2113945B02	R1073M1	0613952R01
C1045M1	2113945B02	R1074M1	0613952R66
C1047M1	2113945Y02	R1075M1	0613952R66
C1048M1	2113945B02	R1076M1	0613952R66
C2000M1	2113945Y02	R1077M1	0613952R66
C2001M1	2113945Y02	R1078M1	0613952R66
C2002M1	2113945B02	R1079M1	0613952R66
C2003M1	21667009162	R1080M1	0613952Q32
C2004M1	2113956B54	R1081M1	0613952Q32
C2005M1	2113946D05	R1082M1	0613952Q32
C2006M1	2113945Y02	R1084M1	0613952R66
C2007M1	2113945Y02	R1088M1	NOT PLACED
C2008M1	2113945B02	R1089M1	0613952R05
C2009M1	21667009162	R1090M1	0613952R05
C2010M1	2113945Y02	R1091M1	NOT PLACED
C2011M1	2113945Y02	R1092M1	0613952M43
C2012M1	2113945Y02	R1093M1	0613952Q73
C2013M1	2113945Y02	R1094M1	0613952M66
C2014M1	2113945B02	R1095M1	0613952Q34
C2015M1	21667009162	R1096M1	0613952Q34
C2016M1	2113956B54	R1097M1	0613952R66
C2020M1	2113956B54	R1098M1	0613952R66
C2021M1	2113956D59	R2000M1	0613952M66
C2022M1	2113956D59	R2002M1	0613952M66
C3102M1	21009337414	R2003M1	0613952M30
C3103M1	21667009166	R3101M1	0613952Z66
C3104M1	2113946F08	R3102M1	0613952M66
C3105M1	2113946J04	R3103M1	0613952N62
C3106M1	2113945C31	R3104M1	0613952M30
C3107M1	2113944C38	R3105M1	0613952R01

Circuit Ref.	Motorola Solutions Part No.	Circuit Ref.	Motorola Solutions Part No.
C3109M1	21667009166	R3106M1	0613952M09
C3110M1	2113944C06	R3107M1	0613952M85
C3111M1	2113946J04	R3108M1	0613952R17
C3112M1	2113945Y02	R3109M1	0613952R17
C3113M1	2113946S35	R3110M1	0613952N55
C3115M1	2113944C06	R3111M1	0613952R32
C3116M1	2113955D13	R3112M1	0613952P12
C3117M1	2113955D13	R3113M1	0613952R17
C3118M1	2113945Y02	R3114M1	0613952N01
C3119M1	2113945Y02	R3115M1	0613952Z63
C3120M1	2113956E60	R3116M1	0613952E83
C3121M1	2113956D58	R3117M1	0613952Q73
C3122M1	2113956A51	R3118M1	0613952R10
C3123M1	2113956A51	R3119M1	0613952Q73
C3124M1	2113946D07	R3120M1	0613952R66
C3125M1	2113946D05	R3121M1	0613952R66
C3126M1	2113944C06	R3122M1	0613952M43
C3127M1	2113946S35	R3123M1	0613952M54
C3128M1	2113946D05	R3124M1	0613952R66
C3129M1	2113945Y02	R3125M1	0613952R66
C3130M1	2113946D05	R3126M1	0613952R66
C3131M1	2113946A02	R3127M1	0613959Y09
C3132M1	2113946D05	R3128M1	0613952M10
C3133M1	2113946D05	R3129M1	0613952M58
C3134M1	2113946S35	R3130M1	0613952R25
C3135M1	2113956A51	R3131M1	0613952R01
C3136M1	21012095001	R3132M1	0613952R01
C3137M1	2113946D05	R3133M1	0613952R29
C3139M1	2113956A51	R3134M1	NOT PLACED
C3140M1	21012095001	R3135M1	0613952R66
C3141M1	2113945Y02	R3136M1	0613952R17
C3142M1	21012102001	R3137M1	0613952R17
C3143M1	21667009366	R3138M1	0613952R17
C3144M1	2113945Y02	R3139M1	0613952R66
C3145M1	2113944C06	R3140M1	0613952Q91

Circuit Ref.	Motorola Solutions Part No.	Circuit Ref.	Motorola Solutions Part No.
C3146M1	21012102001	R3141M1	0613959Y13
C3149M1	2113956A51	R3142M1	NOT PLACED
C3150M1	2113956C37	R3143M1	0613952Q91
C3151M1	2113945B02	R3144M1	0613952R66
C3152M1	2113944C06	R3145M1	0613959Y09
C3153M1	2113946J04	R3146M1	0613952M81
C3154M1	2113955D13	R3147M1	0613952M43
C3155M1	2113945Y02	R3148M1	0613952R66
C3156M1	2113945Y02	R3149M1	0613952R01
C3157M1	2113945Y02	R3150M1	0613952N62
C3160M1	2113945Y02	R3151M1	0613952R25
C3161M1	NOT PLACED	R3153M1	0613952R66
C3171M1	2113946D07	R3154M1	0613952Q89
C3173M1	2113946D07	R3155M1	0613952Q89
C3175M1	2113946A01	R3156M1	0613952R17
C3176M1	2113944C48	R3157M1	0613952R01
C3177M1	2113946F08	R3158M1	0613952R66
C3186M1	2113944C06	R3159M1	0613952R01
C3187M1	2113946J04	R3160M1	0613952Q89
C3188M1	2113945Y02	R3161M1	0613952Q73
C3189M1	2113956B21	R3162M1	0613952Q85
C3190M1	2113956B21	R3163M1	0613952R01
C3200M1	21667009166	R3164M1	0613952Q75
C3201M1	21667009166	R3165M1	0613952R01
C3203M1	2113955D37	R3166M1	0613952R17
C3204M1	2113955D37	R3167M1	0613952R01
C3205M1	21667009166	R3168M1	0613952Q73
C3206M1	21667009166	R3169M1	0613952R01
C3208M1	2113956C37	R3170M1	0613952R01
C3209M1	2113945Y02	R3171M1	NOT PLACED
C3210M1	2113945Y02	R3172M1	NOT PLACED
C3211M1	2113945A11	R3173M1	0613952R66
C3212M1	2113955D37	R3174M1	0613952R66
C3213M1	2113945A03	R3175M1	0689774Y02
C3214M1	2113955D37	R3176M1	0689774Y02

Circuit Ref.	Motorola Solutions Part No.	Circuit Ref.	Motorola Solutions Part No.
C3215M1	CA000819A01	R3177M1	0613952R66
C3216M1	2113945Y02	R3178M1	0615871H01
C3217M1	2113956B91	R3179M1	0613952R17
C3218M1	2113956A51	R3180M1	0613952R01
C3219M1	2113956A51	R3181M1	NOT PLACED
C3220M1	2113946F05	R3182M1	0613952R66
C3221M1	2113945Y02	R3183M1	0613952H92
C3222M1	2113956A51	R3184M1	0613952M30
C3223M1	2113945Y02	R3185M1	0613952M85
C3224M1	2113946F05	R3186M1	0613952M09
C3225M1	2113945Y02	R3187M1	0613952A01
C3226M1	NOT PLACED	R3200M1	0613952C44
C3227M1	2113946F05	R3201M1	0613952Q49
C3228M1	2113945Y02	R3202M1	0613952C44
C3229M1	2113956A51	R3203M1	0613952Q49
C3230M1	2113945Y02	R3204M1	0613952C44
C3231M1	2113945Y02	R3205M1	0613952C44
C3232M1	2113945Y02	R3206M1	0613952R01
C3233M1	2113945A09	R3207M1	0613952R01
C3234M1	2113945Y02	R3208M1	0613952N30
C3235M1	21012102001	R3209M1	0613952R03
C3236M1	2113945C31	R3210M1	0613952Q67
C3237M1	21009337414	R3211M1	0613952N30
C3238M1	2113945A09	R3212M1	0613952R03
C3239M1	2113945A09	R3213M1	0613952Q42
C3240M1	2113956B91	R3214M1	0613952J25
C3241M1	2113956B91	R3215M1	0613952R01
C3242M1	2113945C31	R3216M1	0613952R17
C3243M1	2113955D37	R3217M1	0613952R01
C3244M1	2113956B91	R3218M1	0613952R01
C3245M1	2113955D37	R3219M1	NOT PLACED
C3246M1	2113945C31	R3220M1	0613952R01
C3247M1	2113945Y02	R3221M1	NOT PLACED
C3248M1	2113945Y02	R3222M1	0613952R01
C3249M1	2113956B91	R3223M1	0613952R66

Circuit Ref.	Motorola Solutions Part No.	Circuit Ref.	Motorola Solutions Part No.
C3250M1	CA000308A01	R3224M1	NOT PLACED
C4000M1	2113945Y02	R3225M1	NOT PLACED
C4001M1	2113945Y02	R3226M1	0613952R01
C4002M1	2113945Y02	R3229M1	0613952R01
C4003M1	2113945Y02	R3230M1	0613952R10
C4010M1	21667009166	R3231M1	0613952R10
C4011M1	21667009166	R3232M1	0613952R10
C4012M1	21667009166	R3233M1	0613952R01
C4013M1	21667009166	R3234M1	NOT PLACED
C4014M1	21667009166	R3235M1	0613952R01
C4015M1	21667009166	R3236M1	0613952R10
C4019M1	21667009166	R3237M1	NOT PLACED
C4020M1	21667009166	R3238M1	0613952R01
C4021M1	21667009166	R3239M1	0613952Q49
C4022M1	21667009166	R3240M1	0613952R01
C4023M1	21667009166	R3241M1	0613952M54
C4025M1	21667009166	R3242M1	0613952R01
C4026M1	21667009166	R3243M1	0613952R01
C4027M1	21667009166	R3244M1	0613952R10
C4028M1	21667009166	R3245M1	NOT PLACED
C4029M1	21667009166	R3246M1	0613952R01
C4030M1	21667009166	R3247M1	0613952Q49
C4100M1	21667009166	R3248M1	0613952R66
C4101M1	21667009166	R3249M1	0613952R66
C4103M1	21667009166	R3250M1	0613952R66
C4104M1	21667009166	R3251M1	0613952R66
C4105M1	21667009166	R3252M1	0613952R66
C4106M1	21667009166	R3253M1	0613952R66
C4107M1	21667009166	R3254M1	0613952R01
C4108M1	21667009166	R3255M1	0613952R66
C4109M1	21667009166	R3256M1	0613952M66
C4110M1	21667009166	R3257M1	0613952R01
C4112M1	21667009166	R3258M1	0613952M66
C4113M1	21667009166	R3259M1	0613952M66
C4114M1	21667009166	R3260M1	0613952M66

Circuit Ref.	Motorola Solutions Part No.	Circuit Ref.	Motorola Solutions Part No.
C4115M1	21667009166	R3261M1	0613952R01
C4116M1	21667009166	R3262M1	0613952R10
C4117M1	21667009166	R3263M1	NOT PLACED
C4118M1	21667009166	R3264M1	0613952R01
C4119M1	21667009166	R3265M1	0613952M66
C4200M1	2113945Y02	R3266M1	0613952R01
C4201M1	2113945Y02	R3267M1	NOT PLACED
C4202M1	21667009166	R3268M1	0613952R01
C4203M1	21667009166	R3269M1	0613952M66
C4204M1	NOT PLACED	R3270M1	0613952R01
C4205M1	21667009166	R3271M1	NOT PLACED
C4206M1	21667009166	R3272M1	0613952R01
C4207M1	21667009166	R3273M1	0613952M66
C4208M1	21667009166	R3274M1	0613952R10
C4209M1	21667009166	R3275M1	0613952R10
C4210M1	21667009166	R3276M1	0613952R10
C4211M1	21667009166	R3277M1	0613952R10
C4212M1	21667009166	R3278M1	0613952R01
C4213M1	21667009166	R3279M1	NOT PLACED
C4214M1	21667009166	R3280M1	NOT PLACED
C4218M1	21667009166	R3281M1	NOT PLACED
C4219M1	21667009339	R3282M1	0613952R66
C4220M1	21667009339	R3283M1	0613952R66
C4221M1	21667009339	R3285M1	0613952R01
C4222M1	21667009339	R3286M1	0613952R66
C4223M1	21667009339	R3287M1	0613952R66
C4224M1	21667009166	R3288M1	0613952R01
C4225M1	21667009166	R3289M1	0613952R01
C4226M1	21667009339	R3290M1	NOT PLACED
C4300M1	NOT PLACED	R3291M1	NOT PLACED
C4301M1	NOT PLACED	R3292M1	0613952R66
C4302M1	NOT PLACED	R3293M1	0613952R66
C4303M1	NOT PLACED	R4001M1	0613952R66
C4304M1	21667009166	R4003M1	0613952R66
C4305M1	21667009376	R4006M1	0613952Q37

Circuit Ref.	Motorola Solutions Part No.	Circuit Ref.	Motorola Solutions Part No.
C4306M1	21667009381	R4007M1	0613952Q37
C4307M1	NOT PLACED	R4008M1	0613952R01
C4308M1	NOT PLACED	R4010M1	0613952R01
C4309M1	21667009166	R4013M1	0613952Q42
C4310M1	21667009166	R4015M1	0613952Q37
C4311M1	2113945Y02	R4021M1	0613952R66
C4312M1	2113945Y02	R4024M1	0613952R01
C4313M1	21667009166	R4025M1	0613952R01
C4314M1	NOT PLACED	R4026M1	0613952R66
C4401M1	NOT PLACED	R4027M1	0613952R66
C4402M1	NOT PLACED	R4028M1	0613952R01
C4403M1	NOT PLACED	R4029M1	0613952R01
C4404M1	NOT PLACED	R4030M1	0613952R01
C4405M1	NOT PLACED	R4031M1	0613952R01
C4406M1	NOT PLACED	R4032M1	0613952R66
C4407M1	NOT PLACED	R4033M1	0613952M43
C4408M1	NOT PLACED	R4034M1	0613952M43
C4409M1	NOT PLACED	R4035M1	0613952R66
C4410M1	NOT PLACED	R4036M1	0613952R66
C4411M1	NOT PLACED	R4037M1	0613952R01
C4412M1	21667009166	R4038M1	0613952R01
C4413M1	21667009166	R4039M1	NOT PLACED
C4414M1	21667009166	R4040M1	NOT PLACED
C4415M1	21667009166	R4041M1	NOT PLACED
C4417M1	21667009166	R4100M1	0613952R01
C4418M1	21667009166	R4101M1	0613952Q77
C4419M1	21667009166	R4102M1	0613958H83
D3104M1	4885489Y01	R4103M1	0613952Q85
D3160M1	4813978C02	R4104M1	0613952Q89
D3161M1	4813978C02	R4105M1	0613952Q89
E1000M1	7686949J15	R4106M1	0613952Q89
E1001M1	7686949J15	R4107M1	0613952R01
E1002M1	7686949J15	R4108M1	0613952Q89
E1003M1	7686949J15	R4109M1	0613952N58
E1004M1	7686949J15	R4110M1	0613952Q85

Circuit Ref.	Motorola Solutions Part No.	Circuit Ref.	Motorola Solutions Part No.
E1005M1	7686949J15	R4111M1	0613952Q85
E1006M1	7685268E01	R4112M1	0613952R01
E3100M1	24012102001	R4113M1	0613952R01
E3101M1	2485410Y02	R4114M1	0613952Q89
E3102M1	2485410Y02	R4115M1	0613952N58
E3103M1	2485410Y02	R4116M1	0613952Q89
E3104M1	7686949J22	R4117M1	0613952R01
E3105M1	7686949J22	R4118M1	0613952R01
E3106M1	7686949J22	R4119M1	0613952R01
E3107M1	7686949J22	R4120M1	0613952N58
E3108M1	7686949J22	R4121M1	0613952Q85
E3109M1	7686949J22	R4122M1	0613952Q85
E3110M1	7686949J22	R4123M1	0613952N58
E3111M1	7686949J22	R4124M1	0613952N58
E3113M1	7686949J22	R4125M1	0613952Q85
E3114M1	2485410Y02	R4126M1	0613952Q85
E3200M1	24012102001	R4127M1	0613952Q85
E3201M1	24012102001	R4128M1	0613952R01
E3202M1	24012107027	R4200M1	0613952R66
E3203M1	24012102001	R4201M1	0613952R66
E3204M1	24012102001	R4202M1	0613952R66
E4000M1	24012107027	R4203M1	0613952R66
E4001M1	7688697V05	R4204M1	0613952R66
E4002M1	24012107027	R4205M1	0613952R66
E4003M1	NOT PLACED	R4206M1	0613952R66
E4004M1	24012102001	R4207M1	0613952R66
E4005M1	2485410Y02	R4208M1	0613952R66
E4100M1	7686949J14	R4209M1	HZ000375A01
E4101M1	24012107027	R4210M1	HZ000375A01
E4102M1	NOT PLACED	R4211M1	HZ000375A01
E4103M1	NOT PLACED	R4212M1	HZ000375A01
E4104M1	NOT PLACED	R4213M1	HZ000375A01
E4200M1	24012107027	R4214M1	HZ000375A01
E4201M1	24012107027	R4215M1	0613952R66
E4202M1	24012107027	R4216M1	0613952R66

Circuit Ref.	Motorola Solutions Part No.	Circuit Ref.	Motorola Solutions Part No.
E4300M1	24012107027	R4217M1	0613952R66
E4405M1	24012107027	R4218M1	0613952R66
E4406M1	7686949J22	R4301M1	NOT PLACED
E4407M1	7686949J22	R4302M1	0613952R66
E4408M1	24012107027	R4303M1	0613952R66
E4409M1	24012102001	R4304M1	0613952R66
F4000M1	65012019001	R4305M1	0613952R66
FL4000M1	24012038001	R4306M1	0613952R66
FL4001M1	24012038001	R4307M1	0613952R66
J4000M1	0915767H01	R4309M1	NOT PLACED
J4001M1	0915556H01	R4310M1	0613952R66
J4100M1	0916017H01	R4311M1	0613952R66
J4200M1	9012053001	R4312M1	0613952R66
J4400M1	9012053001	R4313M1	NOT PLACED
L3100M1	24012091002	R4314M1	0613952R66
P1000M1	2887818K02	R4315M1	0613952R66
Q1000M1	4815263H01	R4316M1	0613952R66
Q1001M1	4815272H01	R4317M1	0613952R66
Q1002M1	4815261H01	SH3100M1	NOT PLACED
Q1004M1	4815261H01	U1000M1	5171320H01
Q1005M1	4815261H01	U1001M1	51012295001
Q3100M1	4815272H01	U1002M1	5189139P01
Q3101M1	4809939C47	U1003M1	5175772B56
Q3102M1	4809939C47	U1004M1	5175772B56
Q3103M1	48009494001	U1005M1	5164852H47
Q3105M1	4809939C47	U1006M1	5185493Y01
Q3160M1	48009494001	U1007M1	5189139P01
Q3161M1	4815272H01	U1008M1	5189139P01
Q3162M1	4813973M07	U1009M1	5115001H02
Q3163M1	48009494001	U1010M1	5171320H01
Q3200M1	4815270H01	U2000M1	51012239003
Q3201M1	4815272H01	U2001M1	MM000129A01
Q3202M1	4815270H01	U3100M1	0104039J08
Q3203M1	4815270H01	U3101M1	5114014A01
Q3204M1	4815270H01	U3102M1	51012069001

Circuit Ref.	Motorola Solutions Part No.	Circuit Ref.	Motorola Solutions Part No.
Q3205M1	4815270H01	U3103M1	51012142001
Q3206M1	4815270H01	U3104M1	5171590Y73
Q3207M1	4815270H01	U3105M1	5114610F01
Q3208M1	4815263H01	U3106M1	51012140001
Q4000M1	4809939C47	U3107M1	51012140001
Q4001M1	4809939C47	U3108M1	51012138001
Q4002M1	4809939C47	U3109M1	5164015H94
Q4100M1	4816023H01	U3110M1	51012208001
Q4101M1	4815261H01	U3111M1	5188690V02
Q4102M1	4815263H01	U3112M1	5114004A35
Q4103M1	48012271001	U3113M1	5188690V02
Q4105M1	48012271001	U3114M1	NOT PLACED
Q4106M1	48012271001	U3115M1	5185937Y01
Q4109M1	48012271001	U3116M1	5171774H01
Q4112M1	48012271001	U3200M1	51009415001
Q4120M1	4809939C47	U3201M1	5114016A18
R1000M1	0613952R66	U3204M1	51009509001
R1001M1	0613952M66	U3205M1	5114016A18
R1002M1	0613952R66	U4000M1	51012082001
R1003M1	0613952R66	U4001M1	51012082001
R1004M1	0613952R66	U4100M1	5189139P01
R1005M1	0613952M66	U4200M1	NOT PLACED
R1007M1	0613952R66	U4201M1	NOT PLACED
R1008M1	0613952R66	U4300M1	51012082001
R1009M1	0613952R66	U4301M1	51012082001
R1010M1	NOT PLACED	VR3103M1	48012095001
R1011M1	NOT PLACED	VR3104M1	48012095002
R1012M1	0613952R66	VR3105M1	4813977M10
R1013M1	0613952M66	VR3200M1	48012049001
R1014M1	NOT PLACED	VR3201M1	4813977A48
R1016M1	NOT PLACED	VR3202M1	4813977A48
R1018M1	NOT PLACED	VR4000M1	4813977M13
R1019M1	0613952R66	VR4001M1	4813977A48
R1020M1	0613952M66	VR4002M1	48012153001
R1021M1	0613952Q73	VR4100M1	4813977A48

Circuit Ref.	Motorola Solutions Part No.	Circuit Ref.	Motorola Solutions Part No.
R1022M1	NOT PLACED	VR4101M1	4813977A48
R1023M1	0613952R66	VR4102M1	4813977A48
R1024M1	NOT PLACED	VR4103M1	4813977A48
R1025M1	0613952Q73	VR4104M1	48012049001
R1026M1	0613952R66	VR4105M1	4813977M13
R1027M1	NOT PLACED	VR4106M1	4813977A48
R1028M1	0613952R66	VR4107M1	4813977A48
R1029M1	0613952R66	VR4108M1	4813977A48
R1030M1	NOT PLACED	VR4109M1	4813977A50
R1031M1	0613952R66	VR4110M1	4815040H01
R1033M1	0613952Q73	VR4111M1	48012153001
R1034M1	0613952R17	-	-



NOTICE: The suffix "M1", "M2", and so on from the Circuit Ref. is removed from the schematics and overlays.

8.3

VHF Low Power Service Information

8.3.1

Allocation of Schematics and Circuit Boards

This chapter shows the schematics for the VHF circuits. The PCB component layouts and the Parts List in this chapter show both the Controller and VHF circuit components.

Diagrams and Parts List for 84012734001-A

Diagrams:

- [Figure 128: Main Board Top Side PCB No. 84012734001-A on page 202](#)
- [Figure 129: Main Board Bottom Side PCB No. 84012734001-A on page 203](#)
- [Figure 130: Overall Schematic Diagram on page 204](#)
- [Figure 131: Receiver Front-End Schematic Diagram on page 205](#)
- [Figure 132: Receiver IF Amp Schematic Diagram on page 206](#)
- [Figure 133: Transmitter Power Amplifier Schematic Diagram on page 207](#)
- [Figure 134: Power Control Schematic Diagram on page 208](#)
- [Figure 135: Transmitter Power Amplifier DC Distribution Schematic Diagram on page 209](#)
- [Figure 136: RFIC Schematic Diagram on page 210](#)
- [Figure 137: Receiver VCO Schematic Diagram on page 211](#)
- [Figure 138: Transmit VCO Schematic Diagram on page 212](#)
- [Figure 139: VCO Buffer Schematic Diagram on page 213](#)

[Parts List for 84012734001-A on page 214](#)

Diagrams and Parts List for 84012734002-B

Diagrams:

- [Figure 140: Main Board Top Side PCB No. 84012734002-B on page 239](#)
- [Figure 141: Main Board Bottom Side PCB No. 84012734002-B on page 240](#)
- [Figure 142: Overall Schematic Diagram on page 241](#)
- [Figure 143: Receiver Front End Schematic Diagram on page 242](#)
- [Figure 144: Receiver IF Amp Schematic Diagram on page 243](#)
- [Figure 145: Transmitter Power Amplifier Schematic Diagram on page 244](#)
- [Figure 146: Power Control Schematic Diagram on page 245](#)
- [Figure 147: Transmitter Power Amplifier DC Distribution Schematic Diagram on page 246](#)
- [Figure 148: RFIC Schematic Diagram on page 247](#)
- [Figure 149: Receiver VCO Schematic Diagram on page 248](#)
- [Figure 150: Transmit VCO Schematic Diagram on page 249](#)
- [Figure 151: VCO Buffer Schematic Diagram on page 250](#)

[Parts List for 84012734002-B on page 251](#)

8.3.1.1

Circuit Board and Schematic Diagrams for 84012734001-A

Figure 128: Main Board Top Side PCB No. 84012734001-A

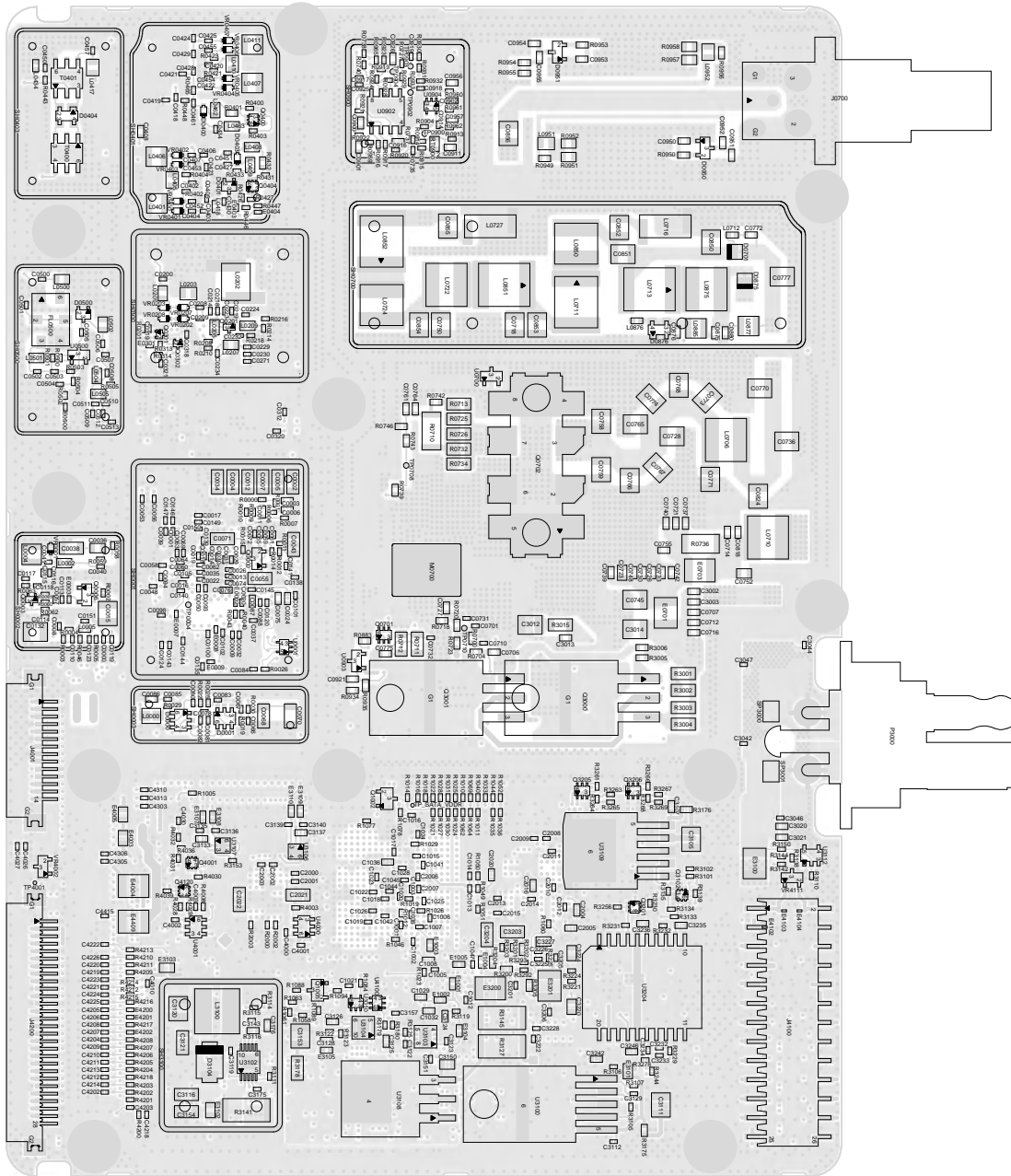

Figure 129: Main Board Bottom Side PCB No. 84012734001-A

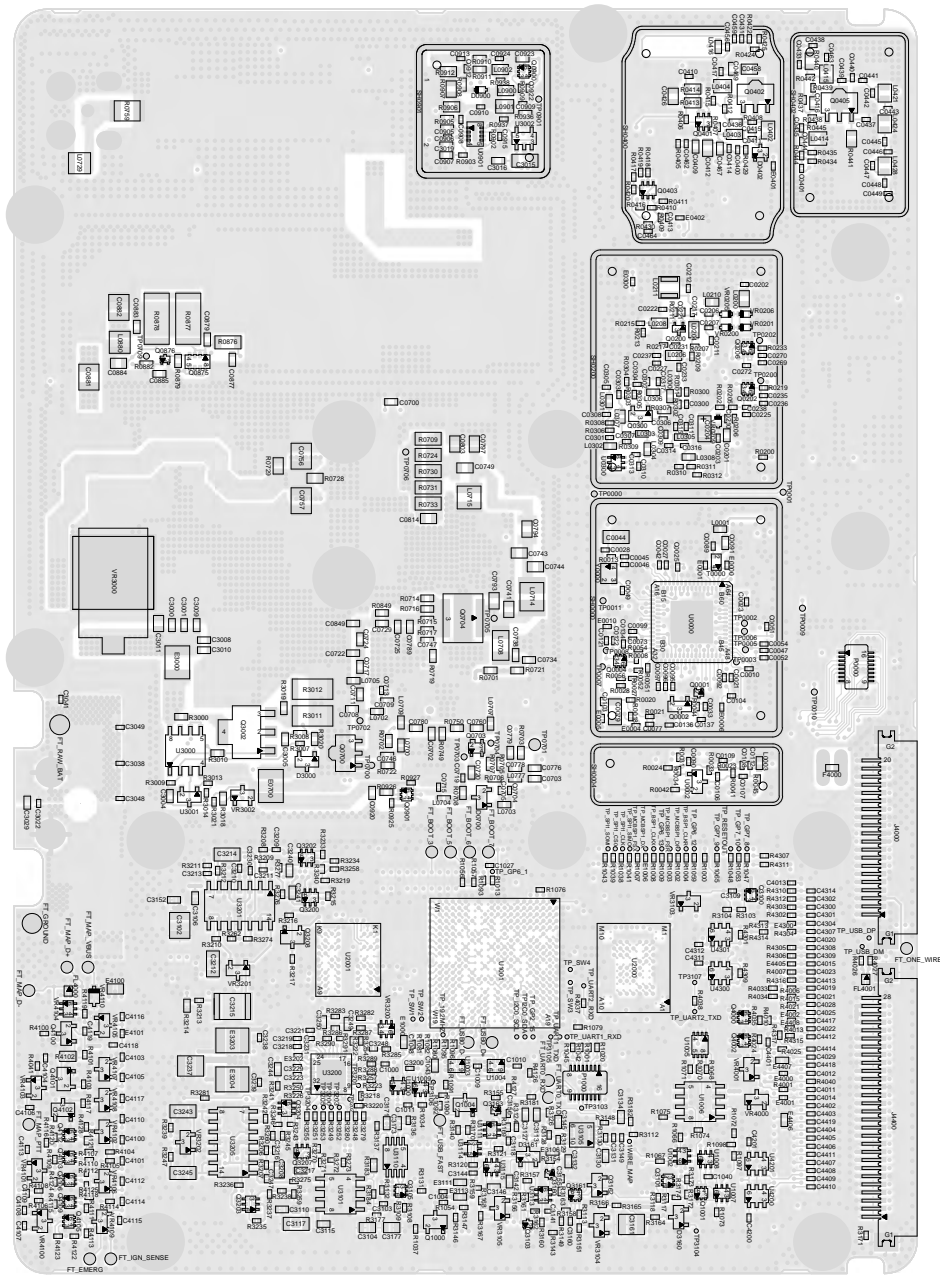
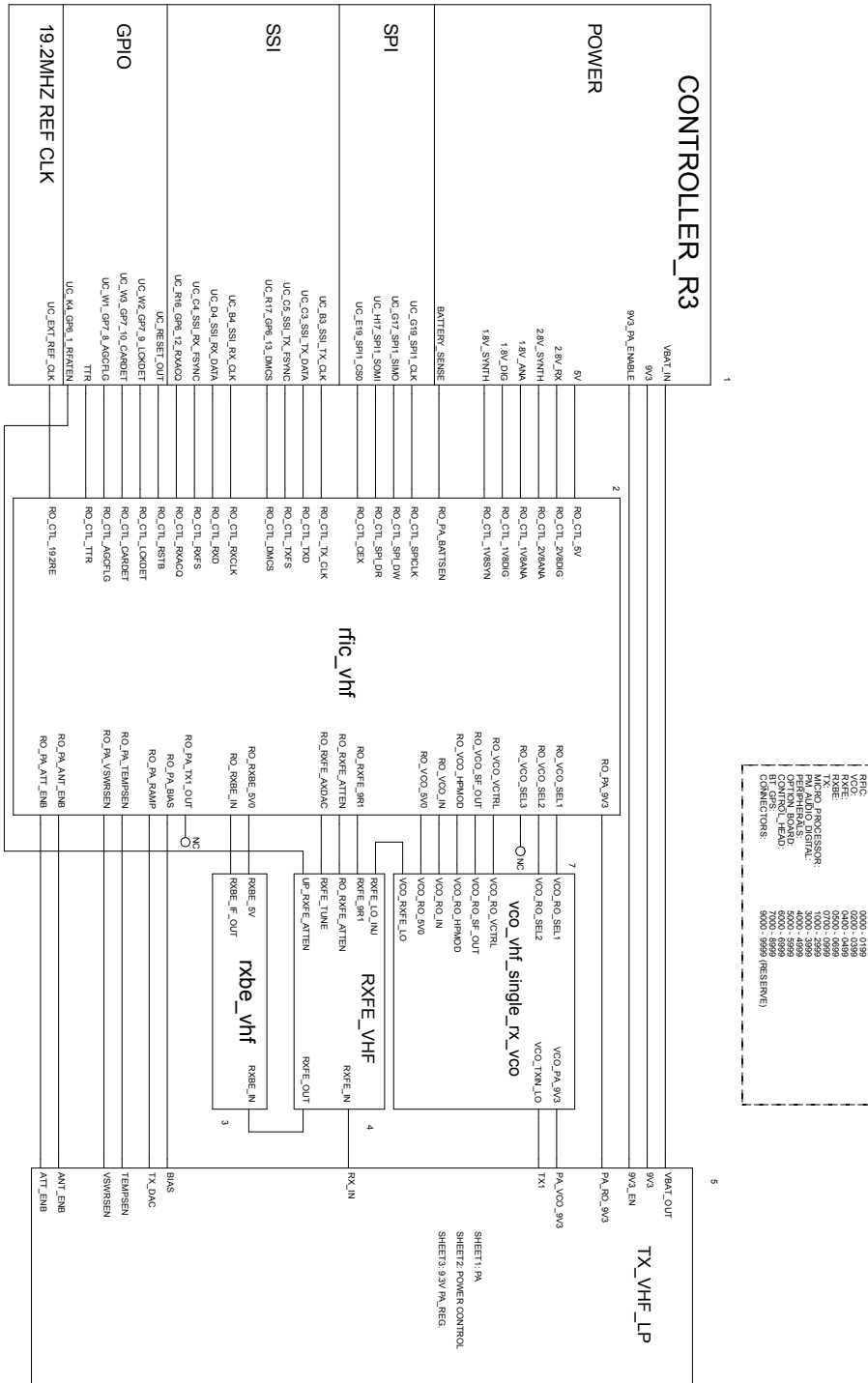

Figure 130: Overall Schematic Diagram



RFIC	0000-0199
VCO	0200-0399
RXBE	0400-0599
RXFE	0600-0699
MCU	0700-0799
MICRO PROCESSOR	0800-0899
PA	0900-0999
PA AUDIO DIGITAL	1000-1099
PA AUDIO ANALOG	1100-1199
OPTICAL BOARD	1200-1299
CONNECTION BOARD	1300-1399
BT GPS	1400-1499
CONNECTORS	1500-1599
	1600-1699
	1700-1799
	1800-1899
	1900-1999
	2000-2099
	2100-2199
	2200-2299
	2300-2399
	2400-2499
	2500-2599
	2600-2699
	2700-2799
	2800-2899
	2900-2999
	3000-3099
	3100-3199
	3200-3299
	3300-3399
	3400-3499
	3500-3599
	3600-3699
	3700-3799
	3800-3899
	3900-3999
	4000-4099
	4100-4199
	4200-4299
	4300-4399
	4400-4499
	4500-4599
	4600-4699
	4700-4799
	4800-4899
	4900-4999
	5000-5099
	5100-5199
	5200-5299
	5300-5399
	5400-5499
	5500-5599
	5600-5699
	5700-5799
	5800-5899
	5900-5999
	6000-6099
	6100-6199
	6200-6299
	6300-6399
	6400-6499
	6500-6599
	6600-6699
	6700-6799
	6800-6899
	6900-6999
	7000-7099
	7100-7199
	7200-7299
	7300-7399
	7400-7499
	7500-7599
	7600-7699
	7700-7799
	7800-7899
	7900-7999
	8000-8099
	8100-8199
	8200-8299
	8300-8399
	8400-8499
	8500-8599
	8600-8699
	8700-8799
	8800-8899
	8900-8999
	9000-9099
	9100-9199
	9200-9299
	9300-9399
	9400-9499
	9500-9599
	9600-9699
	9700-9799
	9800-9899
	9900-9999

Figure 131: Receiver Front-End Schematic Diagram

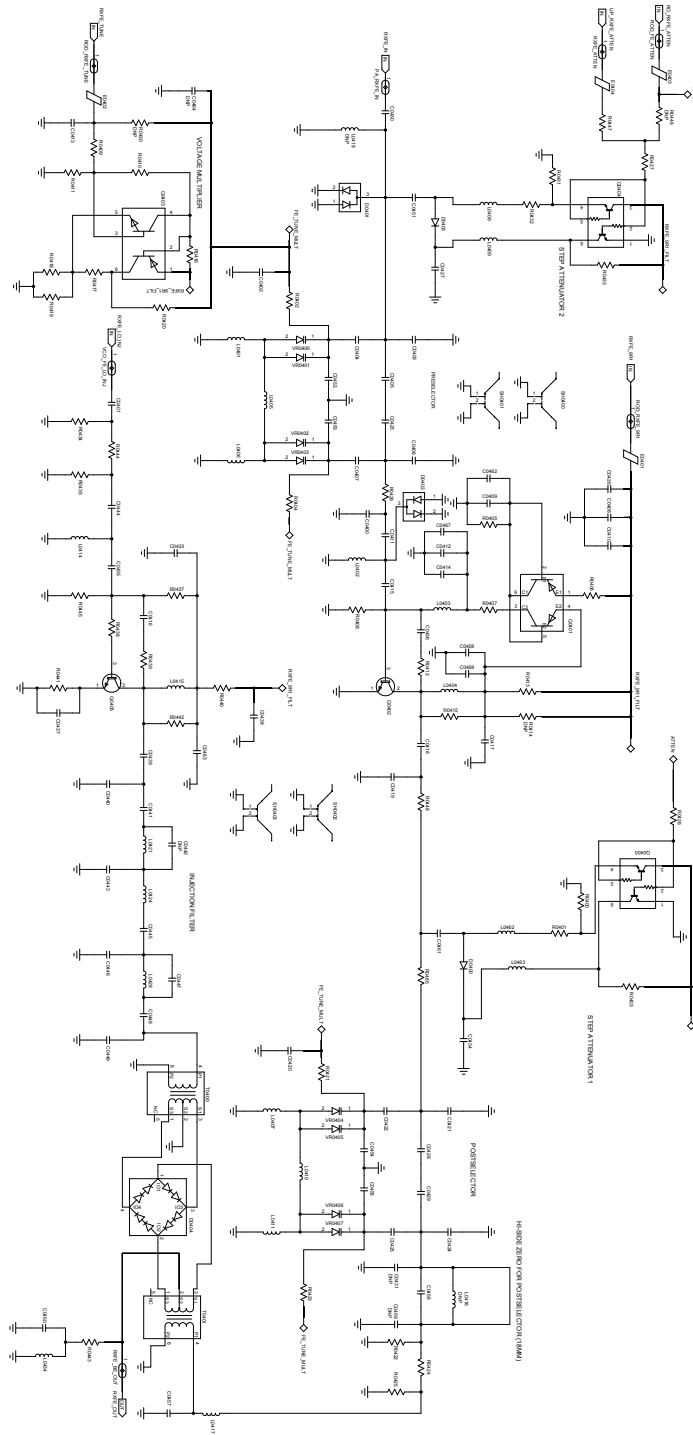

Figure 132: Receiver IF Amp Schematic Diagram

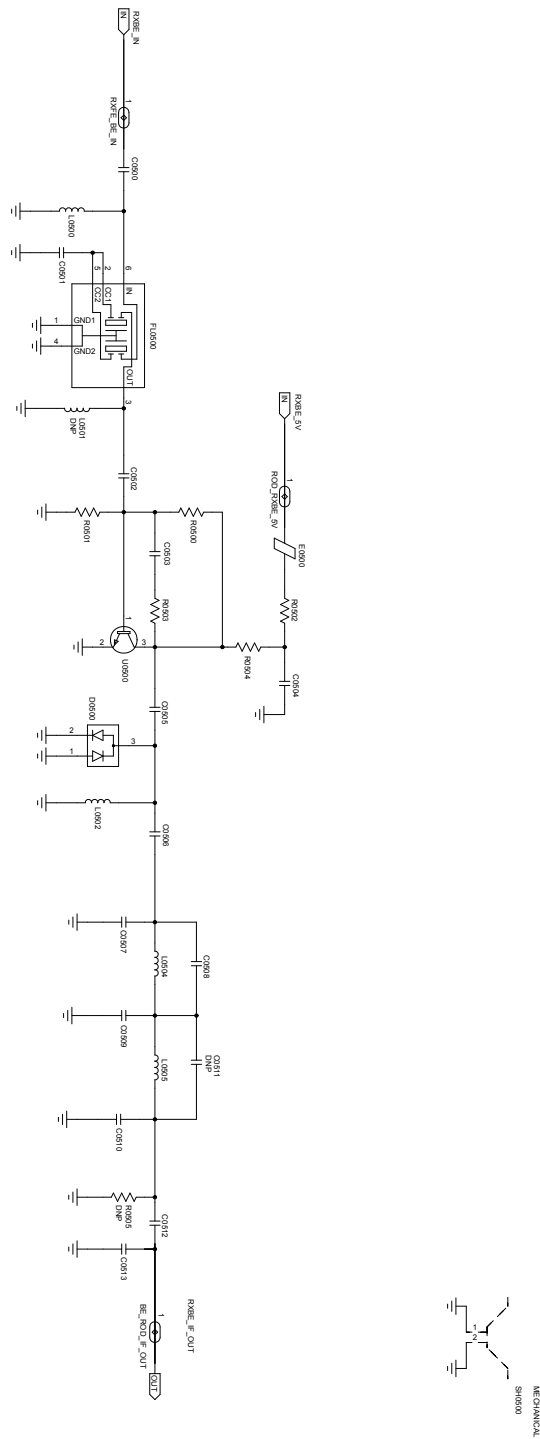

Figure 133: Transmitter Power Amplifier Schematic Diagram

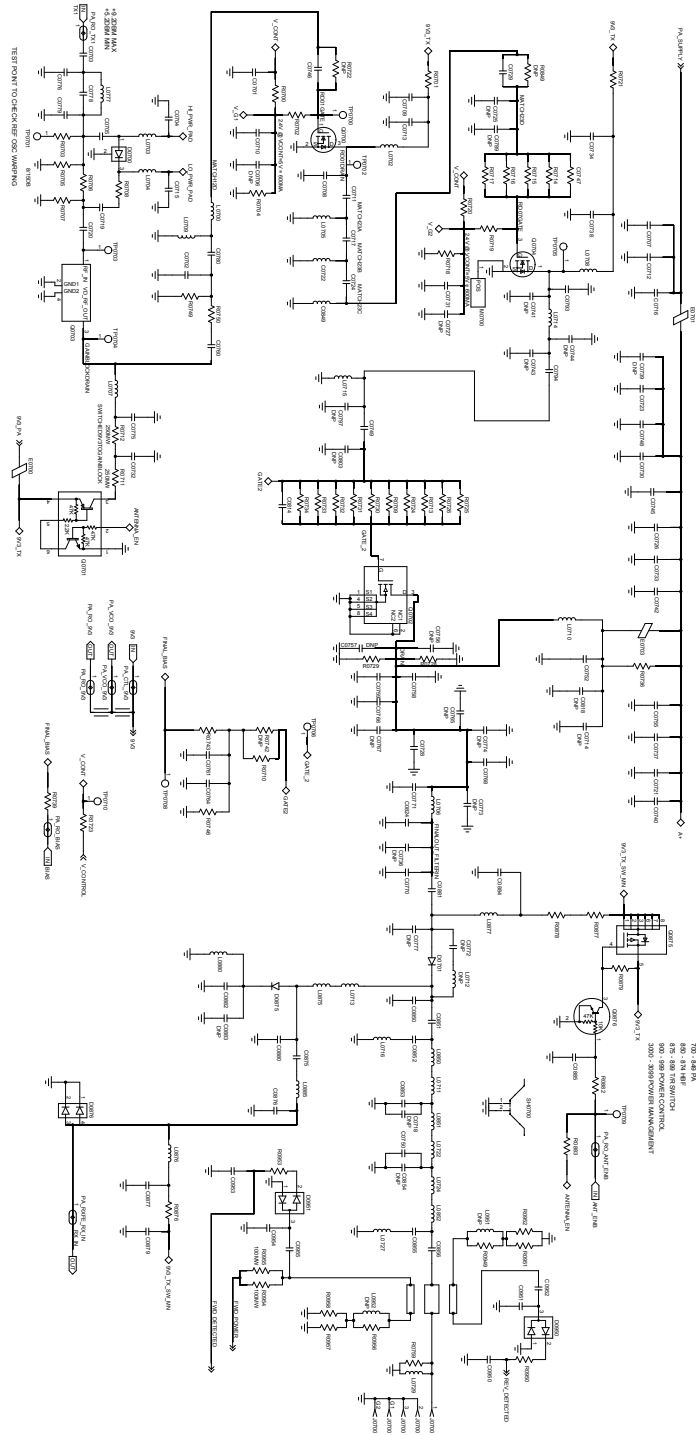

Figure 134: Power Control Schematic Diagram

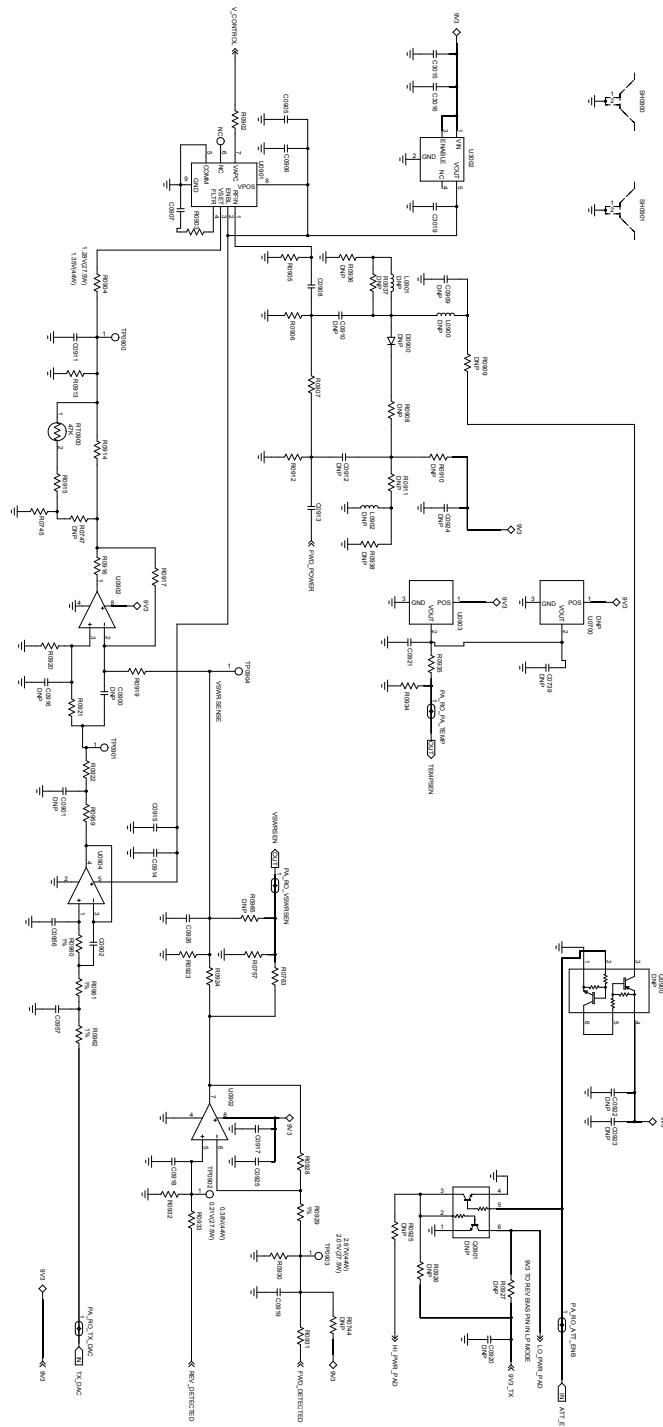

Figure 135: Transmitter Power Amplifier DC Distribution Schematic Diagram

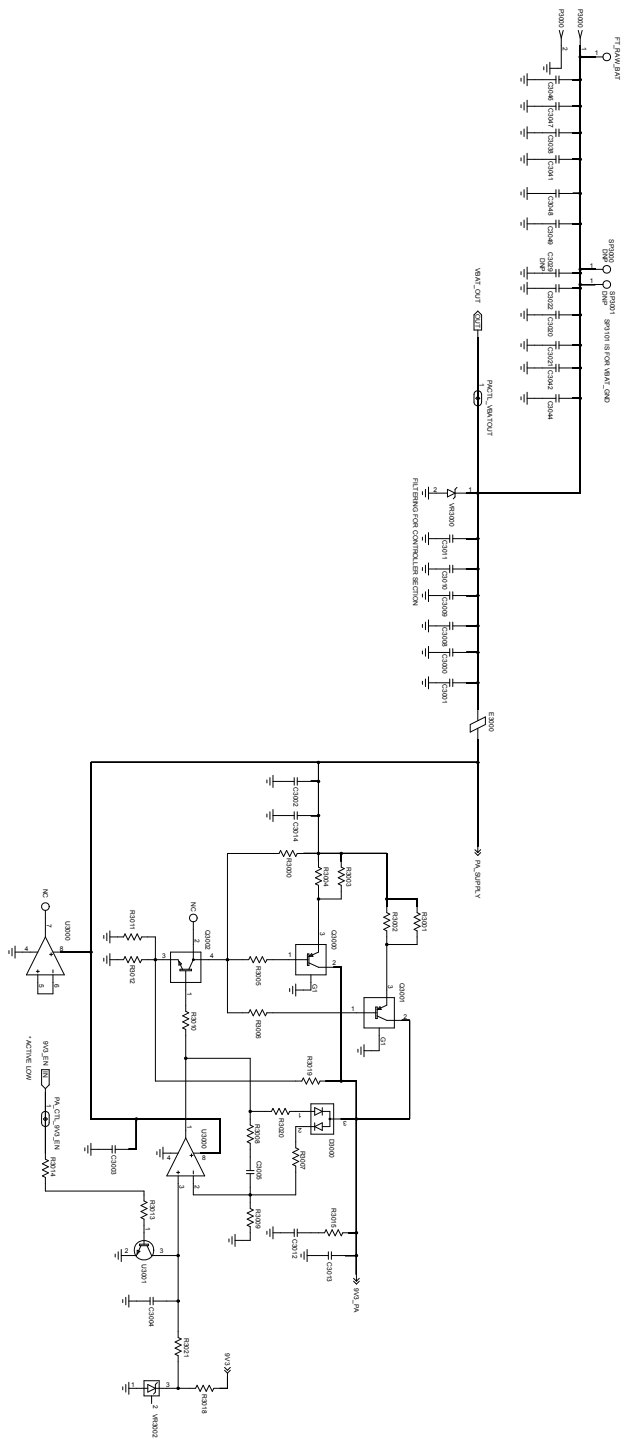

Figure 136: RFIC Schematic Diagram

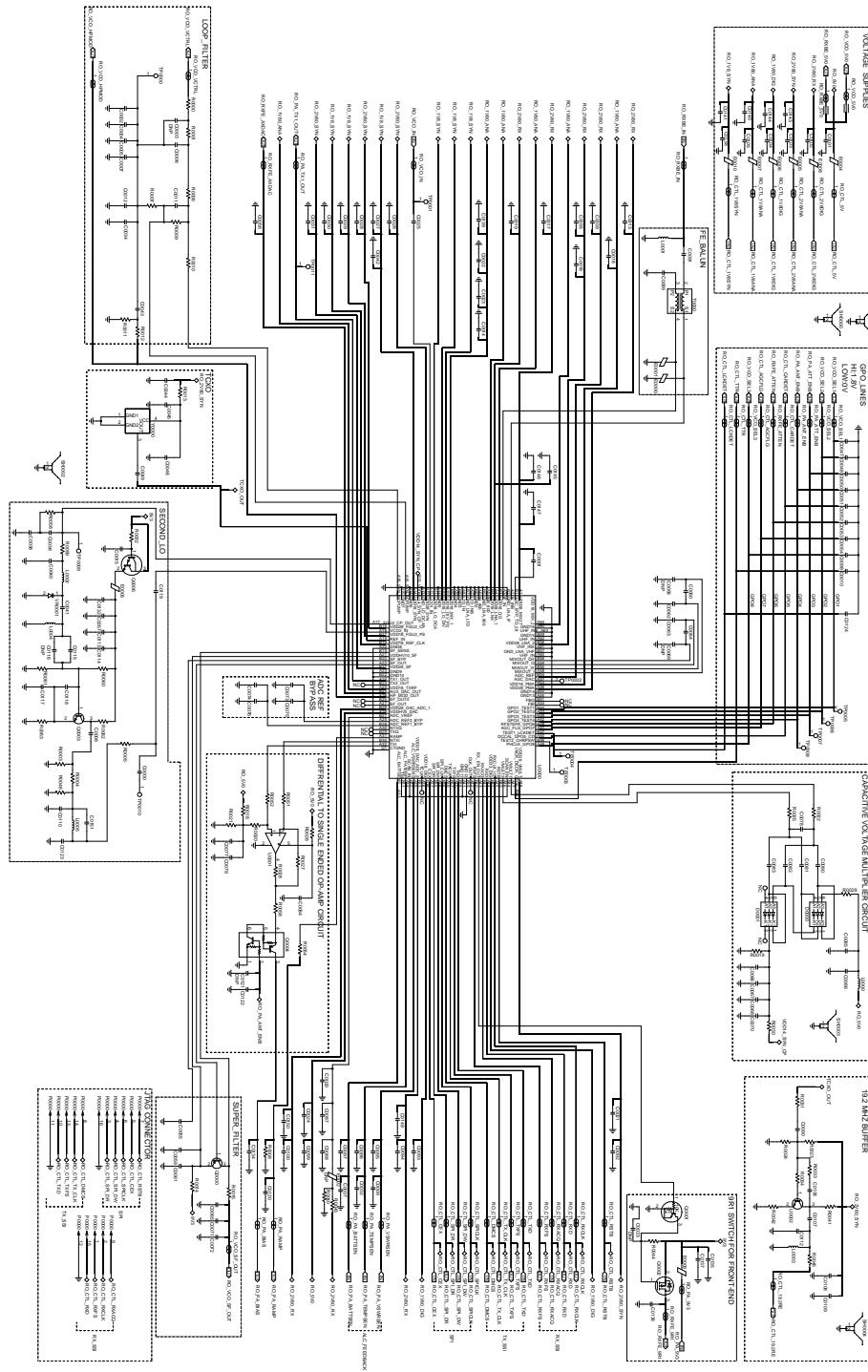

Figure 137: Receiver VCO Schematic Diagram

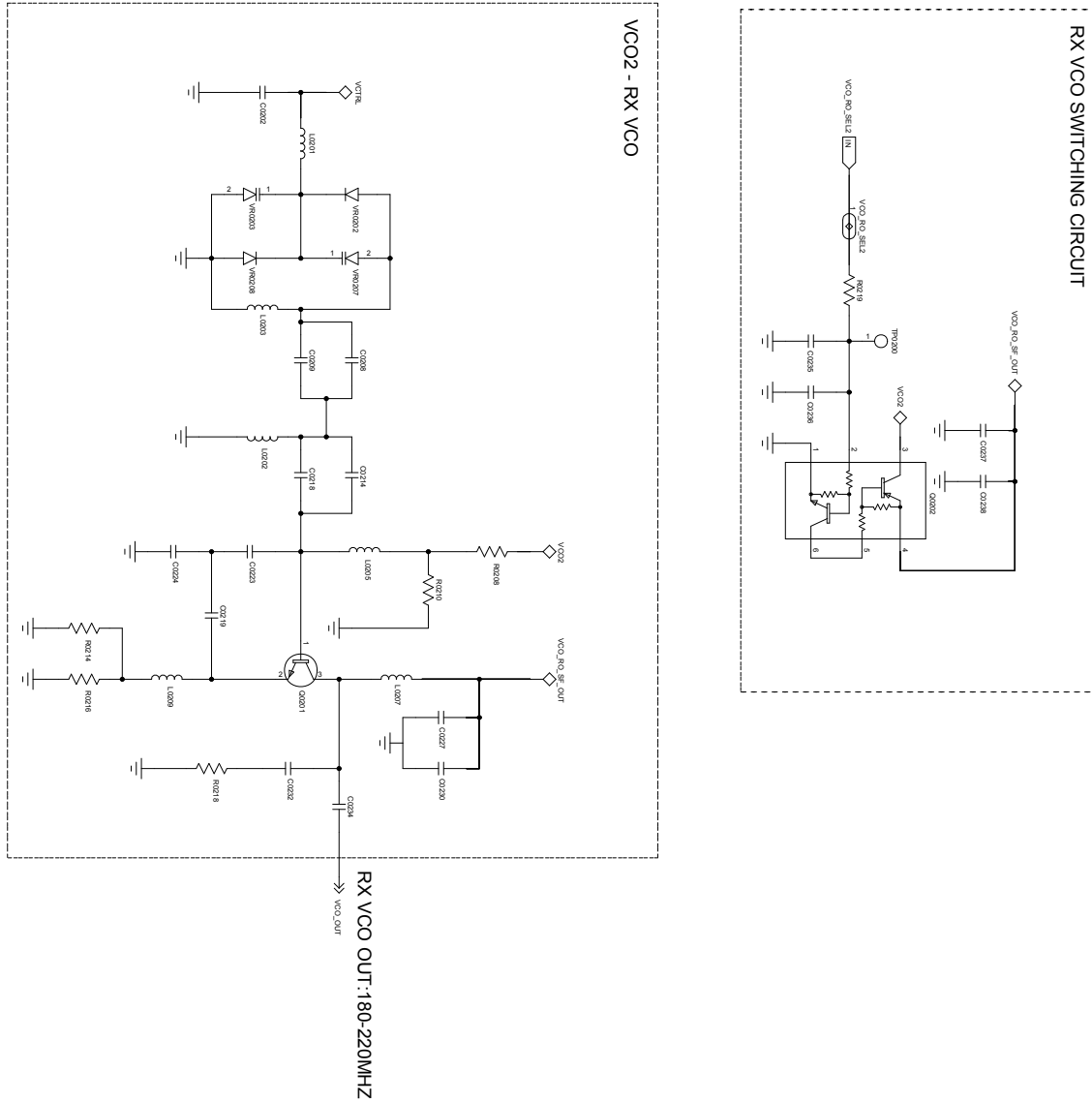
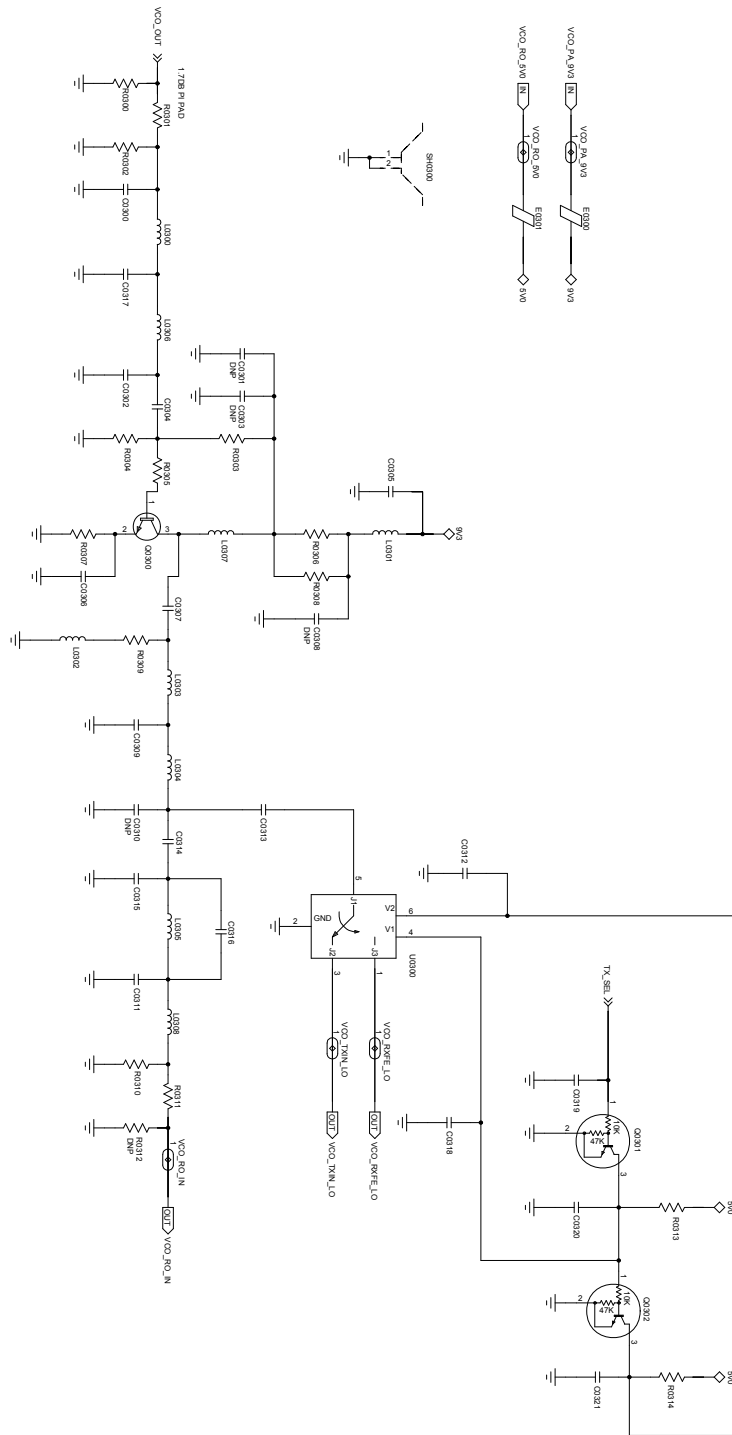

Figure 139: VCO Buffer Schematic Diagram



8.3.1.2

Parts List for 84012734001-A

Table 17: VHF Radio Part List

Circuit Ref.	Motorola Soutions Part No.	Circuit Ref.	Motorola Soutions Part No.
C0000M2	21667009311	L0500M3	24667005045
C0001M2	21667009170	L0501M3	NOT PLACED
C0002M2	21012044001	L0502M3	24667000031
C0003M2	NOT PLACED	L0504M3	24667000031
C0004M2	21012044001	L0505M3	24667000031
C0005M2	21012044001	L0700M5	24667008020
C0006M2	2113945C31	L0702M5	24667008028
C0007M2	21012044001	L0703M5	24667008031
C0008M2	21667009355	L0704M5	24667008031
C0009M2	21667009166	L0705M5	24667008025
C0010M2	2113945A10	L0706M5	2485873L01
C0011M2	2113945C31	L0707M5	24667008031
C0012M2	21012044001	L0708M5	2479990G01
C0013M2	2113945Y02	L0709M5	24667008022
C0014M2	2113945Y02	L0710M5	2485873L01
C0015M2	2113946J03	L0711M5	2485873L02
C0016M2	2113945A10	L0712M5	NOT PLACED
C0017M2	2113945Y02	L0713M5	2485873L02
C0018M2	2113945A10	L0714M5	2460591B73
C0019M2	2113945Y02	L0715M5	2460591A77
C0020M2	2113945A10	L0716M5	2415385H05
C0021M2	2113945Y02	L0722M5	2485873L01
C0022M2	2113945Y02	L0724M5	2485873L01
C0023M2	2113945Y02	L0727M5	2415385H08
C0024M2	21012102001	L0729M5	2414032B60
C0025M2	2113945A10	L0777M5	24667008020
C0026M2	21667009174	L0850M5	2485873L01
C0027M2	2113945Y02	L0851M5	2485873L02
C0028M2	2113945Y02	L0852M5	2485873L02
C0029M2	2113945A10	L0875M5	2485873L01
C0030M2	2113945A10	L0876M5	24667008031
C0031M2	2113945Y02	L0877M5	24009343030

Circuit Ref.	Motorola Soutions Part No.	Circuit Ref.	Motorola Soutions Part No.
C0032M2	21667009166	L0880M5	24009343030
C0033M2	NOT PLACED	L0885M5	2414032B49
C0034M2	21012044001	L0900M5	24667000031
C0035M2	2113945A10	L0901M5	NOT PLACED
C0036M2	21012044004	L0902M5	NOT PLACED
C0037M2	21667009166	L0951M5	NOT PLACED
C0038M2	21012044001	L0952M5	NOT PLACED
C0039M2	2113945Y02	L3100M1	24012091002
C0040M2	2113945A10	M0700M5	2686201B02
C0041M2	21667009366	P0000M2	NOT PLACED
C0042M2	21667009166	P1000M1	2887818K02
C0043M2	21012044001	P3000M5	09009344001
C0044M2	2113955D45	Q0000M2	4813973A13
C0045M2	2113945Y02	Q0001M2	48009494001
C0046M2	21667009166	Q0002M2	4813970A59
C0047M2	2113945A10	Q0003M2	48012195001
C0048M2	2113945A10	Q0004M2	4815272H01
C0049M2	2113945B02	Q0006M2	4813973A04
C0050M2	2113945A10	Q0200M7	48012195001
C0051M2	2113945A10	Q0201M7	48012195001
C0052M2	2113945A10	Q0202M7	4815272H01
C0053M2	2113945A10	Q0206M7	4815272H01
C0054M2	2113945A10	Q0300M7	4802197J95
C0055M2	2113955D37	Q0301M7	48009494001
C0056M2	2113945Y02	Q0302M7	48009494001
C0057M2	2113945B02	Q0400M4	4815271H01
C0058M2	NOT PLACED	Q0401M4	4815267H01
C0059M2	21667009166	Q0402M4	48012230001
C0060M2	2113945A69	Q0403M4	4815270H01
C0061M2	2113945Y02	Q0404M4	4815271H01
C0062M2	NOT PLACED	Q0405M4	48012230001
C0063M2	NOT PLACED	Q0700M5	4816547H01
C0064M2	2113945A69	Q0701M5	4816013H01
C0065M2	2113945Y02	Q0702M5	48012067002
C0066M2	2113945B02	Q0703M5	4802246J29

Circuit Ref.	Motorola Soutions Part No.	Circuit Ref.	Motorola Soutions Part No.
C0067M2	2113945Y02	Q0704M5	4816548H01
C0068M2	2113955D37	Q0875M5	4813970A62
C0069M2	NOT PLACED	Q0876M5	48009494001
C0070M2	2113955D37	Q0900M5	4815272H01
C0071M2	2113955D37	Q0901M5	4815271H01
C0072M2	21667009166	Q1000M1	4815263H01
C0073M2	21667009166	Q1001M1	4815272H01
C0074M2	21667009166	Q1002M1	4815261H01
C0075M2	2113946S35	Q1004M1	4815261H01
C0076M2	2113946S35	Q1005M1	4815261H01
C0077M2	21667009166	Q3000M5	0105959T72
C0078M2	21667009372	Q3001M5	0105959T72
C0079M2	2113955D37	Q3002M5	4813973B01
C0080M2	2113945B02	Q3100M1	4815272H01
C0081M2	2113945B02	Q3101M1	4809939C47
C0082M2	2113945B02	Q3102M1	4809939C47
C0083M2	2113945B02	Q3103M1	48009494001
C0084M2	21667009166	Q3105M1	4809939C47
C0085M2	2113945A10	Q3160M1	48009494001
C0086M2	2113945C31	Q3161M1	4815272H01
C0087M2	2113946S35	Q3162M1	4813973M07
C0088M2	2113945Y02	Q3163M1	48009494001
C0089M2	2113945Y02	Q3200M1	4815270H01
C0090M2	2113945B02	Q3201M1	4815272H01
C0091M2	2113944C45	Q3202M1	4815270H01
C0092M2	2113945A10	Q3203M1	4815270H01
C0093M2	2113945Y02	Q3204M1	4815270H01
C0094M2	2113945Y02	Q3205M1	4815270H01
C0095M2	2113945A13	Q3206M1	4815270H01
C0096M2	2113945B02	Q3207M1	4815270H01
C0097M2	2113945B02	Q3208M1	4815263H01
C0098M2	2113945A10	Q4000M1	4809939C47
C0099M2	2113945Y02	Q4001M1	4809939C47
C0100M2	2113945Y02	Q4002M1	4809939C47
C0101M2	2113945A10	Q4100M1	4816023H01

Circuit Ref.	Motorola Soutions Part No.	Circuit Ref.	Motorola Soutions Part No.
C0102M2	2113945A10	Q4101M1	4815261H01
C0103M2	2113945A10	Q4102M1	4815263H01
C0104M2	2113945A10	Q4103M1	48012271001
C0105M2	2113945A10	Q4105M1	48012271001
C0106M2	2113945B02	Q4106M1	48012271001
C0107M2	2113945B02	Q4109M1	48012271001
C0108M2	2113945A10	Q4112M1	48012271001
C0109M2	2113945Y02	Q4120M1	4809939C47
C0110M2	21667009381	R0000M2	0613952R66
C0112M2	21667009166	R0001M2	0613952R66
C0113M2	2113945A10	R0002M2	0613952Q96
C0114M2	2113945Y02	R0003M2	0613952Q57
C0115M2	21667009372	R0004M2	0613952Q34
C0116M2	NOT PLACED	R0005M2	0613952R66
C0117M2	21667009388	R0006M2	0613952Q25
C0118M2	21667009378	R0007M2	0613952Q51
C0119M2	2113945A10	R0008M2	0613952R01
C0120M2	2113945A10	R0009M2	0613952Q58
C0121M2	NOT PLACED	R0010M2	0613952R66
C0122M2	21667009166	R0011M2	0613952Q35
C0123M2	21667009381	R0012M2	0613952Q81
C0124M2	21667009166	R0013M2	0613952Q35
C0132M2	2113946J03	R0014M2	0613952R66
C0134M2	2113945A10	R0015M2	0613952R66
C0135M2	21667009166	R0018M2	0613952Q80
C0136M2	21667009166	R0019M2	0613952R01
C0137M2	2113945Y02	R0020M2	0613952R12
C0138M2	2113945A10	R0021M2	0613952Q80
C0139M2	2113945A10	R0022M2	0613952R66
C0140M2	2113945Y02	R0023M2	0613952Q83
C0141M2	2113945Y02	R0024M2	0613952Q80
C0143M2	2113945Y02	R0025M2	0613952R66
C0144M2	2113945Y02	R0026M2	0613952R66
C0145M2	21667009166	R0027M2	0613952R12
C0146M2	2113945A10	R0028M2	0613952R66

Circuit Ref.	Motorola Soutions Part No.	Circuit Ref.	Motorola Soutions Part No.
C0147M2	2113945A10	R0029M2	0613952Q25
C0149M2	2113945A10	R0030M2	0613952R66
C0150M2	2113945A10	R0031M2	0613952R66
C0151M2	21667009372	R0033M2	0613952R01
C0200M7	2113945A10	R0034M2	0613952Q57
C0201M7	NOT PLACED	R0040M2	0613952Q70
C0202M7	2113945A10	R0041M2	0613952Q58
C0203M7	NOT PLACED	R0042M2	0613952Q42
C0204M7	NOT PLACED	R0043M2	0613952Q73
C0206M7	21667009355	R0044M2	0613952R25
C0207M7	21667009355	R0045M2	0613952R66
C0208M7	21667009366	R0046M2	0613952Q57
C0209M7	21667009366	R0051M2	0613952R01
C0210M7	21667009274	R0052M2	0613952R01
C0211M7	NOT PLACED	R0054M2	0613952M25
C0212M7	NOT PLACED	R0056M2	0613952R66
C0214M7	21667009315	R0058M2	0613952Q81
C0217M7	21667009204	R0059M2	0613952R66
C0218M7	21667009315	R0060M2	0613952Q86
C0219M7	2113945A04	R0061M2	0613952Q85
C0221M7	21667009371	R0062M2	0613952Q61
C0222M7	21667009374	R0063M2	0613952Q64
C0223M7	21667009378	R0200M7	0613952R66
C0224M7	21667009377	R0201M7	0613952R66
C0225M7	2113945Y02	R0202M7	0613952R27
C0227M7	2113945Y02	R0205M7	0613952R07
C0229M7	2113945A10	R0206M7	0613952R05
C0230M7	2113945A10	R0207M7	0613952Q86
C0231M7	2113945A10	R0208M7	0613952Q78
C0232M7	2113945A10	R0209M7	0613952Q85
C0233M7	21667009284	R0210M7	0613952Q73
C0234M7	21667009284	R0211M7	0613952Q18
C0235M7	2113945A10	R0213M7	0613952Q67
C0236M7	2113945Y02	R0214M7	0613952Q67
C0237M7	2113945A10	R0215M7	0613952Q67

Circuit Ref.	Motorola Soutions Part No.	Circuit Ref.	Motorola Soutions Part No.
C0238M7	2113945Y02	R0216M7	0613952Q67
C0269M7	2113945A10	R0217M7	0613952Q49
C0270M7	2113945Y02	R0218M7	0613952Q49
C0271M7	2113945A10	R0219M7	0613952R66
C0272M7	2113945Y02	R0233M7	0613952R66
C0300M7	21667009378	R0300M7	0613952Q66
C0301M7	NOT PLACED	R0301M7	0613952Q25
C0302M7	21667009300	R0302M7	0613952Q66
C0303M7	NOT PLACED	R0303M7	0613952Q94
C0304M7	21667009392	R0304M7	0613952Q89
C0305M7	2113945Y02	R0305M7	0613952Q32
C0306M7	2113945A09	R0306M7	0613952Q49
C0307M7	2113945A02	R0307M7	0613952H46
C0308M7	NOT PLACED	R0308M7	0613952Q49
C0309M7	21667009370	R0309M7	0613952Q42
C0310M7	NOT PLACED	R0310M7	0613952Q39
C0311M7	21667009368	R0311M7	0613952R66
C0312M7	2113945A10	R0312M7	NOT PLACED
C0313M7	2113945A10	R0313M7	0613952Q73
C0314M7	21667009366	R0314M7	0613952Q73
C0315M7	21667009315	R0400M4	0613952R01
C0316M7	21667009371	R0401M4	0613952H81
C0317M7	21667009377	R0402M4	0613952R25
C0318M7	2113945A10	R0403M4	0613952R01
C0319M7	2113945A10	R0404M4	0613952R25
C0320M7	2113945A10	R0405M4	0613952R05
C0321M7	2113945A10	R0406M4	0613952Q91
C0400M4	21667009279	R0407M4	0613952Q91
C0401M4	2113945A10	R0408M4	0613952Q73
C0402M4	2113945A10	R0409M4	0613952R66
C0403M4	21667009291	R0410M4	0613952R01
C0404M4	21667009385	R0411M4	0613952R01
C0405M4	21667009282	R0412M4	0613952Q75
C0406M4	21667009291	R0413M4	0613958H44
C0407M4	21667009385	R0414M4	NOT PLACED

Circuit Ref.	Motorola Soutions Part No.	Circuit Ref.	Motorola Soutions Part No.
C0408M4	2113945C31	R0415M4	0613952Q75
C0409M4	2113945C31	R0416M4	0613952Q69
C0410M4	2113945A10	R0417M4	0613952Q75
C0411M4	2113945A10	R0418M4	0613952Q69
C0412M4	2113946F05	R0419M4	0613952Q69
C0413M4	21667009166	R0420M4	0613952R25
C0414M4	2113945A10	R0421M4	0613952R25
C0415M4	21667009388	R0422M4	0613952Q53
C0416M4	2113945C31	R0423M4	0613952R25
C0417M4	2113945A10	R0424M4	0613952Q39
C0418M4	21667009383	R0425M4	0613952Q53
C0419M4	21667009315	R0426M4	0613952Q87
C0420M4	2113945A10	R0427M4	0613952Q87
C0421M4	21667009291	R0429M4	0613952R66
C0422M4	21667009385	R0430M4	NOT PLACED
C0423M4	21667009282	R0431M4	0613952R01
C0424M4	21667009291	R0432M4	0613952H75
C0425M4	21667009385	R0433M4	0613952R01
C0426M4	2113946F05	R0434M4	0613952L46
C0427M4	2113945A05	R0435M4	0613952L46
C0428M4	21667009282	R0437M4	0613952Q80
C0429M4	21667009282	R0438M4	0613952Q25
C0430M4	2113945A10	R0439M4	0613952Q69
C0431M4	NOT PLACED	R0440M4	0613958H25
C0433M4	2113945A10	R0441M4	0613958H44
C0434M4	2113945A05	R0442M4	0613952Q83
C0435M4	21667009388	R0443M4	0613952Q46
C0436M4	2113945C31	R0444M4	0613952K25
C0437M4	2113945A10	R0445M4	0613952Q75
C0438M4	2113945A10	R0446M4	NOT PLACED
C0439M4	21667009365	R0447M4	0613952R66
C0440M4	21667009364	R0448M4	0613952Q25
C0441M4	21667009373	R0465M4	0613952R66
C0442M4	NOT PLACED	R0500M3	0613952R08
C0443M4	21667009373	R0501M3	0613952R03

Circuit Ref.	Motorola Soutions Part No.	Circuit Ref.	Motorola Soutions Part No.
C0444M4	21667009388	R0502M3	0613952Q81
C0445M4	21667009375	R0503M3	0613952Q87
C0446M4	21667009372	R0504M3	0613952Q61
C0447M4	21667009303	R0505M3	NOT PLACED
C0448M4	21667009373	R0700M5	0613952J01
C0449M4	21667009364	R0701M5	0613952G67
C0450M4	21667009386	R0702M5	0613952H49
C0451M4	2113945A10	R0703M5	0613952J01
C0452M4	21667009378	R0704M5	0613952J01
C0453M4	21667009378	R0705M5	0613952H48
C0454M4	21667009378	R0706M5	0613952H53
C0455M4	21667009378	R0707M5	0613952H48
C0456M4	2113945A10	R0708M5	0613952H46
C0457M4	21667009372	R0709M5	0613958S49
C0458M4	2113946F05	R0710M5	0613959Q42
C0459M4	NOT PLACED	R0711M5	0613958S49
C0461M4	2113945A10	R0712M5	0613958S49
C0462M4	2113945A10	R0713M5	0613958S49
C0463M4	2113945A10	R0714M5	0613952H42
C0464M4	NOT PLACED	R0715M5	0613952H42
C0467M4	2113956B21	R0716M5	0613952H42
C0469M4	2113956B21	R0717M5	0613952H42
C0500M3	21667009371	R0718M5	0613952H96
C0501M3	21667009355	R0719M5	0613952H89
C0502M3	2113945Y02	R0720M5	0613952J01
C0503M3	2113945Y02	R0721M5	0613952G67
C0504M3	2113945Y02	R0722M5	NOT PLACED
C0505M3	21667009370	R0723M5	0613952G67
C0506M3	21667009371	R0724M5	0613958S49
C0507M3	21667009307	R0725M5	0613958S49
C0508M3	21667009332	R0726M5	0613958S49
C0509M3	21667009380	R0727M5	NOT PLACED
C0510M3	21667009307	R0728M5	0613958J49
C0511M3	NOT PLACED	R0729M5	0613958J49
C0512M3	21667009390	R0730M5	0613958S49

Circuit Ref.	Motorola Soutions Part No.	Circuit Ref.	Motorola Soutions Part No.
C0513M3	21667009378	R0731M5	0613958S49
C0700M5	NOT PLACED	R0732M5	0613958S49
C0701M5	21667009174	R0733M5	0613958S49
C0702M5	2113944C34	R0734M5	0613958S49
C0703M5	2113944C51	R0735M5	0613952R66
C0704M5	21667009174	R0736M5	0613959Q25
C0705M5	21667009174	R0737M5	NOT PLACED
C0706M5	NOT PLACED	R0738M5	0613952N43
C0707M5	2113945C31	R0739M5	0613952H73
C0708M5	21667011438	R0740M5	0613952P01
C0709M5	2113945C04	R0742M5	NOT PLACED
C0710M5	21667009174	R0743M5	0613952J17
C0711M5	2113944C06	R0746M5	0613952J25
C0712M5	2113945L49	R0749M5	0613952H41
C0713M5	21667009174	R0750M5	0613952H37
C0714M5	NOT PLACED	R0759M5	0613959H12
C0715M5	21667009174	R0849M5	NOT PLACED
C0716M5	2113944C51	R0876M5	0613958S73
C0717M5	2113944C35	R0877M5	0613959Y37
C0718M5	NOT PLACED	R0878M5	0613959Y37
C0719M5	21667009174	R0879M5	0613952J25
C0720M5	2113944C51	R0882M5	0613952G67
C0721M5	2113945L37	R0883M5	0613952G67
C0722M5	24667008018	R0902M5	0613952R66
C0723M5	NOT PLACED	R0903M5	0613952N01
C0724M5	2113944C84	R0904M5	0613952R66
C0725M5	NOT PLACED	R0905M5	0613952H42
C0726M5	2113944C51	R0906M5	0613958H49
C0727M5	NOT PLACED	R0907M5	0613958H56
C0728M5	2111078B13	R0908M5	0613952H32
C0729M5	2113944C46	R0909M5	0613952R66
C0730M5	2113945L49	R0910M5	0613952H91
C0731M5	21667009174	R0911M5	0613952H85
C0732M5	2113945A09	R0912M5	0613958H49
C0733M5	2113944C45	R0913M5	0613952M51

Circuit Ref.	Motorola Soutions Part No.	Circuit Ref.	Motorola Soutions Part No.
C0734M5	2113944C51	R0914M5	0613952M71
C0736M5	NOT PLACED	R0915M5	0613952Z76
C0737M5	2113944C04	R0916M5	0613952R66
C0738M5	2113944C46	R0917M5	0613952P01
C0739M5	NOT PLACED	R0919M5	0613952P01
C0740M5	2113945C25	R0920M5	0613952N01
C0741M5	NOT PLACED	R0921M5	0613952N01
C0742M5	2113944C30	R0922M5	0613952R66
C0743M5	NOT PLACED	R0923M5	0613952M43
C0744M5	NOT PLACED	R0924M5	0613952N01
C0745M5	21009337414	R0925M5	0613952Q59
C0746M5	2113944C06	R0926M5	0613952H79
C0747M5	0613952H42	R0927M5	0613952N01
C0748M5	2113945C31	R0928M5	0613952P30
C0749M5	2113944F05	R0929M5	0613952N81
C0750M5	2111078B33	R0930M5	0613952Z61
C0752M5	2113944F05	R0931M5	0613952Z26
C0755M5	2113944C36	R0932M5	0613952N51
C0756M5	NOT PLACED	R0933M5	0613952M66
C0757M5	NOT PLACED	R0934M5	0613952J17
C0758M5	2111078B43	R0935M5	0613952H91
C0759M5	2111078B42	R0936M5	0613952H91
C0760M5	2113944C51	R0937M5	0613952R66
C0761M5	2113944C45	R0938M5	0613952R66
C0764M5	2113944C51	R0949M5	0613952G67
C0765M5	NOT PLACED	R0950M5	0613952G67
C0766M5	2111078B13	R0951M5	0613958H55
C0767M5	NOT PLACED	R0952M5	0613958H53
C0768M5	2111078B16	R0953M5	0613952G67
C0770M5	2111078B31	R0954M5	0613952H39
C0771M5	2111078B46	R0955M5	0613952H39
C0772M5	NOT PLACED	R0956M5	0613952G67
C0773M5	NOT PLACED	R0957M5	0613958H55
C0774M5	NOT PLACED	R0958M5	0613958H53
C0775M5	2113944C06	R0959M5	0613952R66

Circuit Ref.	Motorola Soutions Part No.	Circuit Ref.	Motorola Soutions Part No.
C0776M5	2113944C31	R0960M5	0613952N58
C0777M5	NOT PLACED	R0961M5	0613952N58
C0778M5	21667011432	R0962M5	0613952N58
C0779M5	2113944C31	R0965M5	NOT PLACED
C0780M5	2113944C06	R1000M1	0613952R66
C0789M5	NOT PLACED	R1001M1	0613952M66
C0793M5	21667007045	R1002M1	0613952R66
C0794M5	21667007047	R1003M1	0613952R66
C0797M5	NOT PLACED	R1004M1	0613952R66
C0803M5	NOT PLACED	R1005M1	0613952M66
C0814M5	2113944F67	R1007M1	0613952R66
C0818M5	NOT PLACED	R1008M1	0613952R66
C0824M5	2111078B13	R1009M1	0613952R66
C0849M5	24667008016	R1010M1	NOT PLACED
C0850M5	2111078B22	R1011M1	NOT PLACED
C0851M5	2111078B40	R1012M1	0613952R66
C0852M5	2111078B11	R1013M1	0613952M66
C0853M5	2111078B34	R1014M1	NOT PLACED
C0854M5	NOT PLACED	R1016M1	NOT PLACED
C0855M5	2111078B08	R1018M1	NOT PLACED
C0856M5	2111078B38	R1019M1	0613952R66
C0875M5	2113944C47	R1020M1	0613952M66
C0876M5	2113944C32	R1021M1	0613952Q73
C0877M5	2113944C06	R1022M1	NOT PLACED
C0879M5	2113944C06	R1023M1	0613952R66
C0880M5	2113944C35	R1024M1	NOT PLACED
C0881M5	2111078B50	R1025M1	0613952Q73
C0882M5	2111078B53	R1026M1	0613952R66
C0883M5	NOT PLACED	R1027M1	NOT PLACED
C0884M5	2113944F05	R1028M1	0613952R66
C0885M5	2113944C51	R1029M1	0613952R66
C0900M5	NOT PLACED	R1030M1	NOT PLACED
C0901M5	NOT PLACED	R1031M1	0613952R66
C0902M5	2113944C51	R1033M1	0613952Q73
C0905M5	2113945C31	R1034M1	0613952R17

Circuit Ref.	Motorola Soutions Part No.	Circuit Ref.	Motorola Soutions Part No.
C0906M5	2113945A10	R1035M1	NOT PLACED
C0907M5	2113945L41	R1036M1	0613952M66
C0908M5	21667009174	R1037M1	0613952M66
C0909M5	21667009174	R1038M1	0613952R66
C0910M5	21667009174	R1039M1	0613952R66
C0911M5	2113944C02	R1040M1	0613952M66
C0912M5	21667009174	R1041M1	0613952R66
C0913M5	21667009174	R1042M1	0613952M66
C0914M5	21667009174	R1043M1	0613952R66
C0915M5	2113946B04	R1044M1	0613952M66
C0916M5	NOT PLACED	R1045M1	0613952M66
C0917M5	21667009174	R1046M1	0613952M66
C0918M5	21667009174	R1047M1	0613952R66
C0919M5	21667009174	R1048M1	0613952R66
C0920M5	2113944C51	R1049M1	0613952Q73
C0921M5	2113944C51	R1050M1	0613952Q73
C0922M5	2113946B04	R1051M1	0613952K68
C0923M5	2113944C51	R1052M1	NOT PLACED
C0924M5	21667009174	R1053M1	0613952R66
C0925M5	2113946B04	R1054M1	0613952M66
C0926M5	2113944C02	R1056M1	0613952Q73
C0950M5	2113944C51	R1057M1	0613952Q73
C0951M5	2113944C30	R1058M1	0613952M66
C0952M5	2113944C51	R1059M1	0613952R66
C0953M5	2113944C51	R1060M1	0613952R66
C0954M5	2113944M27	R1061M1	0613952R66
C0955M5	2113944C51	R1062M1	NOT PLACED
C0956M5	2113944C01	R1063M1	NOT PLACED
C0957M5	2113944C49	R1064M1	NOT PLACED
C1000M1	2113945Y02	R1065M1	0613952R66
C1001M1	2113945Y02	R1066M1	0613952M66
C1002M1	2113946K03	R1067M1	0613952M66
C1003M1	2113945Y02	R1068M1	0613952R32
C1004M1	2113945Y02	R1069M1	NOT PLACED
C1005M1	2113945Y02	R1070M1	0613952Q77

Circuit Ref.	Motorola Soutions Part No.	Circuit Ref.	Motorola Soutions Part No.
C1006M1	2113945Y02	R1071M1	0613952Q77
C1007M1	2113945Y02	R1072M1	0613952Q49
C1008M1	2113946D05	R1073M1	0613952R01
C1009M1	2113945Y02	R1074M1	0613952R66
C1010M1	2113945Y02	R1075M1	0613952R66
C1011M1	2113945B02	R1076M1	0613952R66
C1012M1	2113945Y02	R1077M1	0613952R66
C1013M1	2113945Y02	R1078M1	0613952R66
C1014M1	2113945Y02	R1079M1	0613952R66
C1015M1	2113945B02	R1080M1	0613952Q32
C1016M1	21667009166	R1081M1	0613952Q32
C1017M1	21667009162	R1082M1	0613952Q32
C1018M1	21667009162	R1084M1	0613952R66
C1019M1	21667009162	R1088M1	NOT PLACED
C1020M1	21667009162	R1089M1	0613952R05
C1021M1	2113945Y02	R1090M1	0613952R05
C1022M1	2113945Y02	R1091M1	NOT PLACED
C1023M1	2113945Y02	R1092M1	0613952M43
C1024M1	2113945Y02	R1093M1	0613952Q73
C1025M1	2113945Y02	R1094M1	0613952M66
C1026M1	2113945Y02	R1095M1	0613952Q34
C1027M1	NOT PLACED	R1096M1	0613952Q34
C1028M1	2113945Y02	R1097M1	0613952R66
C1029M1	2113956B54	R1098M1	0613952R66
C1032M1	2113956B54	R2000M1	0613952M66
C1035M1	2113945B02	R2002M1	0613952M66
C1036M1	2113946D05	R2003M1	0613952M30
C1040M1	2113945Y02	R3000M5	0613952H60
C1041M1	2113945B02	R3001M5	0615871H01
C1042M1	2113945Y02	R3002M5	0615871H01
C1043M1	2113956B54	R3003M5	0615871H01
C1044M1	2113945B02	R3004M5	0615871H01
C1045M1	2113945B02	R3005M5	0613952H25
C1047M1	2113945Y02	R3006M5	0613952H25
C1048M1	2113945B02	R3007M5	0613952M30

Circuit Ref.	Motorola Soutions Part No.	Circuit Ref.	Motorola Soutions Part No.
C2000M1	2113945Y02	R3008M5	0613952G67
C2001M1	2113945Y02	R3009M5	0613952M43
C2002M1	2113945B02	R3010M5	0613952G67
C2003M1	21667009162	R3011M5	0613959Q60
C2004M1	2113956B54	R3012M5	0613959Q60
C2005M1	2113946D05	R3013M5	0613952R01
C2006M1	2113945Y02	R3014M5	0613952R01
C2007M1	2113945Y02	R3015M5	0615871H01
C2008M1	2113945B02	R3018M5	0613952H73
C2009M1	21667009162	R3019M5	0613952H60
C2010M1	2113945Y02	R3020M5	0613952G67
C2011M1	2113945Y02	R3021M5	0613952R25
C2012M1	2113945Y02	R3101M1	0613952Z66
C2013M1	2113945Y02	R3102M1	0613952M66
C2014M1	2113945B02	R3103M1	0613952N62
C2015M1	21667009162	R3104M1	0613952M30
C2016M1	2113956B54	R3105M1	0613952R01
C2020M1	2113956B54	R3106M1	0613952M09
C2021M1	2113956D59	R3107M1	0613952M85
C2022M1	2113956D59	R3108M1	0613952R17
C3000M5	2113944C38	R3109M1	0613952R17
C3001M5	2113944C06	R3110M1	0613952N55
C3002M5	2113944C06	R3111M1	0613952R32
C3003M5	2113945C31	R3112M1	0613952P12
C3004M5	2113945C02	R3113M1	0613952R17
C3005M5	2113945C02	R3114M1	0613952N01
C3008M5	2113944C51	R3115M1	0613952Z63
C3009M5	2113945C31	R3116M1	0613952E83
C3010M5	2113944C46	R3117M1	0613952Q73
C3011M5	2113945G53	R3118M1	0613952R10
C3012M5	2113946J04	R3119M1	0613952Q73
C3013M5	2113945C31	R3120M1	0613952R66
C3014M5	21009337414	R3121M1	0613952R66
C3015M5	2113946G01	R3122M1	0613952M43
C3016M5	2113945C31	R3123M1	0613952M54

Circuit Ref.	Motorola Soutions Part No.	Circuit Ref.	Motorola Soutions Part No.
C3019M5	2113946S35	R3124M1	0613952R66
C3020M5	2113945C26	R3125M1	0613952R66
C3021M5	2113944C06	R3126M1	0613952R66
C3022M5	2113945A10	R3127M1	0613959Y09
C3029M5	NOT PLACED	R3128M1	0613952M10
C3038M5	21667009169	R3129M1	0613952M58
C3041M5	21667009169	R3130M1	0613952R25
C3042M5	21667009169	R3131M1	0613952R01
C3044M5	21667009169	R3132M1	0613952R01
C3046M5	21667009174	R3133M1	0613952R29
C3047M5	21667009174	R3134M1	NOT PLACED
C3048M5	21667009174	R3135M1	0613952R66
C3049M5	21667009174	R3136M1	0613952R17
C3102M1	21009337414	R3137M1	0613952R17
C3103M1	21667009166	R3138M1	0613952R17
C3104M1	2113946F08	R3139M1	0613952R66
C3105M1	2113946J04	R3140M1	0613952Q91
C3106M1	2113945C31	R3141M1	0613959Y13
C3107M1	2113944C38	R3142M1	NOT PLACED
C3109M1	21667009166	R3143M1	0613952Q91
C3110M1	2113944C06	R3144M1	0613952R66
C3111M1	2113946J04	R3145M1	0613959Y09
C3112M1	2113945Y02	R3146M1	0613952M85
C3113M1	2113946S35	R3147M1	0613952M43
C3115M1	2113944C06	R3148M1	0613952R66
C3116M1	2113955D13	R3149M1	0613952R01
C3117M1	2113955D13	R3150M1	0613952N62
C3118M1	2113945Y02	R3151M1	0613952R25
C3119M1	2113945Y02	R3153M1	0613952R66
C3120M1	2113956E60	R3154M1	0613952Q89
C3121M1	2113956D58	R3155M1	0613952Q89
C3122M1	2113956A51	R3156M1	0613952R17
C3123M1	2113956A51	R3157M1	0613952R01
C3124M1	2113946D07	R3158M1	0613952R66
C3125M1	2113946D05	R3159M1	0613952R01

Circuit Ref.	Motorola Soutions Part No.	Circuit Ref.	Motorola Soutions Part No.
C3126M1	2113944C06	R3160M1	0613952Q89
C3127M1	2113946S35	R3161M1	0613952Q73
C3128M1	2113946D05	R3162M1	0613952Q85
C3129M1	2113945Y02	R3163M1	0613952R01
C3130M1	2113946D05	R3164M1	0613952Q75
C3131M1	2113946A02	R3165M1	0613952R01
C3132M1	2113946D05	R3166M1	0613952R17
C3133M1	2113946D05	R3167M1	0613952R01
C3134M1	2113946S35	R3168M1	0613952Q73
C3135M1	2113956A51	R3169M1	0613952R01
C3136M1	21012095001	R3170M1	0613952R01
C3137M1	2113946D05	R3171M1	NOT PLACED
C3139M1	2113956A51	R3172M1	NOT PLACED
C3140M1	21012095001	R3173M1	0613952R66
C3141M1	2113945Y02	R3174M1	0613952R66
C3142M1	21012102001	R3175M1	0689774Y02
C3143M1	21667009366	R3176M1	0689774Y02
C3144M1	2113945Y02	R3177M1	0613952R66
C3145M1	2113944C06	R3178M1	0615871H01
C3146M1	21012102001	R3179M1	0613952R17
C3149M1	2113956A51	R3180M1	0613952R01
C3150M1	2113956C37	R3181M1	NOT PLACED
C3151M1	2113945B02	R3182M1	0613952R66
C3152M1	2113944C06	R3183M1	0613952H92
C3153M1	2113946J04	R3184M1	0613952M30
C3154M1	2113955D13	R3200M1	0613952C44
C3155M1	2113945Y02	R3201M1	0613952Q49
C3156M1	2113945Y02	R3202M1	0613952C44
C3157M1	2113945Y02	R3203M1	0613952Q49
C3160M1	2113945Y02	R3204M1	0613952C44
C3161M1	NOT PLACED	R3205M1	0613952C44
C3171M1	2113946D07	R3206M1	0613952R01
C3173M1	2113946D07	R3207M1	0613952R01
C3175M1	2113946A01	R3208M1	0613952N30
C3176M1	2113944C48	R3209M1	0613952R03

Circuit Ref.	Motorola Soutions Part No.	Circuit Ref.	Motorola Soutions Part No.
C3177M1	2113946F08	R3210M1	0613952Q67
C3200M1	21667009166	R3211M1	0613952N30
C3201M1	21667009166	R3212M1	0613952R03
C3203M1	2113955D37	R3213M1	0613952Q42
C3204M1	2113955D37	R3214M1	0613952J25
C3205M1	21667009166	R3215M1	0613952R01
C3206M1	21667009166	R3216M1	0613952R17
C3208M1	2113956C37	R3217M1	0613952R01
C3209M1	2113945Y02	R3218M1	0613952R01
C3210M1	2113945Y02	R3219M1	NOT PLACED
C3211M1	2113945A11	R3220M1	0613952R01
C3212M1	2113955D37	R3221M1	NOT PLACED
C3213M1	2113945A03	R3222M1	0613952R01
C3214M1	2113955D37	R3223M1	0613952R66
C3215M1	2113956F49	R3224M1	NOT PLACED
C3216M1	2113945Y02	R3225M1	NOT PLACED
C3217M1	2113956B91	R3226M1	0613952R01
C3218M1	2113956A51	R3229M1	0613952R01
C3219M1	2113956A51	R3230M1	0613952R10
C3220M1	2113946F05	R3231M1	0613952R10
C3221M1	2113945Y02	R3232M1	0613952R10
C3222M1	2113956A51	R3233M1	0613952R01
C3223M1	2113945Y02	R3234M1	NOT PLACED
C3224M1	2113946F05	R3235M1	0613952R01
C3225M1	2113945Y02	R3236M1	0613952R10
C3226M1	NOT PLACED	R3237M1	NOT PLACED
C3227M1	2113946F05	R3238M1	0613952R01
C3228M1	2113945Y02	R3239M1	0613952Q49
C3229M1	2113956A51	R3240M1	0613952R01
C3230M1	2113945Y02	R3241M1	0613952M54
C3231M1	2113945Y02	R3242M1	0613952R01
C3232M1	2113945Y02	R3243M1	0613952R01
C3233M1	2113945A09	R3244M1	0613952R10
C3234M1	2113945Y02	R3245M1	NOT PLACED
C3235M1	21012102001	R3246M1	0613952R01

Circuit Ref.	Motorola Soutions Part No.	Circuit Ref.	Motorola Soutions Part No.
C3236M1	2113945C31	R3247M1	0613952Q49
C3237M1	21009337414	R3248M1	0613952R66
C3238M1	2113945A09	R3249M1	0613952R66
C3239M1	2113945A09	R3250M1	0613952R66
C3240M1	2113956B91	R3251M1	0613952R66
C3241M1	2113956B91	R3252M1	0613952R66
C3242M1	2113945C31	R3253M1	0613952R66
C3243M1	2113955D37	R3254M1	0613952R01
C3244M1	2113956B91	R3255M1	0613952R66
C3245M1	2113955D37	R3256M1	0613952M66
C3246M1	2113945C31	R3257M1	0613952R01
C3247M1	2113945Y02	R3258M1	0613952M66
C3248M1	2113945Y02	R3259M1	0613952M66
C3249M1	2113956B91	R3260M1	0613952M66
C3250M1	2113956B91	R3261M1	0613952R01
C4000M1	2113945Y02	R3262M1	0613952R10
C4001M1	2113945Y02	R3263M1	NOT PLACED
C4002M1	2113945Y02	R3264M1	0613952R01
C4003M1	2113945Y02	R3265M1	0613952M66
C4010M1	21667009166	R3266M1	0613952R01
C4011M1	21667009166	R3267M1	NOT PLACED
C4012M1	21667009166	R3268M1	0613952R01
C4013M1	21667009166	R3269M1	0613952M66
C4014M1	21667009166	R3270M1	0613952R01
C4015M1	21667009166	R3271M1	NOT PLACED
C4019M1	21667009166	R3272M1	0613952R01
C4020M1	21667009166	R3273M1	0613952M66
C4021M1	21667009166	R3274M1	0613952R10
C4022M1	21667009166	R3275M1	0613952R10
C4023M1	21667009166	R3276M1	0613952R10
C4025M1	21667009166	R3277M1	0613952R10
C4026M1	21667009166	R3278M1	0613952R01
C4027M1	21667009166	R3279M1	NOT PLACED
C4028M1	21667009166	R3280M1	NOT PLACED
C4029M1	21667009166	R3281M1	NOT PLACED

Circuit Ref.	Motorola Soutions Part No.	Circuit Ref.	Motorola Soutions Part No.
C4030M1	21667009166	R3282M1	0613952R66
C4100M1	21667009166	R3283M1	0613952R66
C4101M1	21667009166	R3285M1	0613952R01
C4103M1	21667009166	R3286M1	0613952R66
C4104M1	21667009166	R3287M1	0613952R66
C4105M1	21667009166	R3288M1	0613952R01
C4106M1	21667009166	R3289M1	0613952R01
C4107M1	21667009166	R3290M1	NOT PLACED
C4108M1	21667009166	R3291M1	NOT PLACED
C4109M1	21667009166	R3292M1	0613952R66
C4110M1	21667009166	R3293M1	0613952R66
C4112M1	21667009166	R4001M1	0613952R66
C4113M1	21667009166	R4003M1	0613952R66
C4114M1	21667009166	R4006M1	0613952Q37
C4115M1	21667009166	R4007M1	0613952Q37
C4116M1	21667009166	R4008M1	0613952R01
C4117M1	21667009166	R4010M1	0613952R01
C4118M1	21667009166	R4013M1	0613952Q42
C4119M1	21667009166	R4015M1	0613952Q37
C4200M1	2113945Y02	R4021M1	0613952R66
C4201M1	2113945Y02	R4024M1	0613952R01
C4202M1	21667009166	R4025M1	0613952R01
C4203M1	21667009166	R4026M1	0613952R66
C4204M1	NOT PLACED	R4027M1	0613952R66
C4205M1	21667009166	R4028M1	0613952R01
C4206M1	21667009166	R4029M1	0613952R01
C4207M1	21667009166	R4030M1	0613952R01
C4208M1	21667009166	R4031M1	0613952R01
C4209M1	21667009166	R4032M1	0613952R66
C4210M1	21667009166	R4033M1	0613952M43
C4211M1	21667009166	R4034M1	0613952M43
C4212M1	21667009166	R4035M1	0613952R66
C4213M1	21667009166	R4036M1	0613952R66
C4214M1	21667009166	R4037M1	0613952R01
C4218M1	21667009166	R4038M1	0613952R01

Circuit Ref.	Motorola Soutions Part No.	Circuit Ref.	Motorola Soutions Part No.
C4219M1	21667009339	R4039M1	NOT PLACED
C4220M1	21667009339	R4040M1	NOT PLACED
C4221M1	21667009339	R4041M1	NOT PLACED
C4222M1	21667009339	R4100M1	0613952R01
C4223M1	21667009339	R4101M1	0613952Q77
C4224M1	21667009166	R4102M1	0613958H83
C4225M1	21667009166	R4103M1	0613952Q85
C4226M1	21667009339	R4104M1	0613952Q89
C4300M1	NOT PLACED	R4105M1	0613952Q89
C4301M1	NOT PLACED	R4106M1	0613952Q89
C4302M1	NOT PLACED	R4107M1	0613952R01
C4303M1	NOT PLACED	R4108M1	0613952Q89
C4304M1	21667009166	R4109M1	0613952N58
C4305M1	21667009376	R4110M1	0613952Q85
C4306M1	21667009381	R4111M1	0613952Q85
C4307M1	NOT PLACED	R4112M1	0613952R01
C4308M1	NOT PLACED	R4113M1	0613952R01
C4309M1	21667009166	R4114M1	0613952Q89
C4310M1	21667009166	R4115M1	0613952N58
C4311M1	2113945Y02	R4116M1	0613952Q89
C4312M1	2113945Y02	R4117M1	0613952R01
C4313M1	21667009166	R4118M1	0613952R01
C4314M1	NOT PLACED	R4119M1	0613952R01
C4401M1	NOT PLACED	R4120M1	0613952N58
C4402M1	NOT PLACED	R4121M1	0613952Q85
C4403M1	NOT PLACED	R4122M1	0613952Q85
C4404M1	NOT PLACED	R4123M1	0613952N58
C4405M1	NOT PLACED	R4124M1	0613952N58
C4406M1	NOT PLACED	R4125M1	0613952Q85
C4407M1	NOT PLACED	R4126M1	0613952Q85
C4408M1	NOT PLACED	R4127M1	0613952Q85
C4409M1	NOT PLACED	R4128M1	0613952R01
C4410M1	NOT PLACED	R4200M1	0613952R66
C4411M1	NOT PLACED	R4201M1	0613952R66
C4412M1	21667009166	R4202M1	0613952R66

Circuit Ref.	Motorola Solutions Part No.	Circuit Ref.	Motorola Solutions Part No.
C4413M1	21667009166	R4203M1	0613952R66
C4414M1	21667009166	R4204M1	0613952R66
C4415M1	21667009166	R4205M1	0613952R66
C4417M1	21667009166	R4206M1	0613952R66
C4418M1	21667009166	R4207M1	0613952R66
C4419M1	21667009166	R4208M1	0613952R66
D0000M2	4815011H01	R4209M1	HZ000375A01
D0001M2	4815011H01	R4210M1	HZ000375A01
D0400M4	4884800Y03	R4211M1	HZ000375A01
D0401M4	4813974A19	R4212M1	HZ000375A01
D0402M4	4813974A19	R4213M1	HZ000375A01
D0403M4	4884800Y03	R4214M1	HZ000375A01
D0404M4	4815090H01	R4215M1	0613952R66
D0500M3	4813974A19	R4216M1	0613952R66
D0700M5	4813974A06	R4217M1	0613952R66
D0701M5	48012160001	R4218M1	0613952R66
D0875M5	48012160001	R4301M1	NOT PLACED
D0876M5	4886622Y06	R4302M1	0613952R66
D0900M5	48012181001	R4303M1	0613952R66
D0950M5	4813974A21	R4304M1	0613952R66
D0951M5	4813974A21	R4305M1	0613952R66
D3000M5	4813978P07	R4306M1	0613952R66
D3104M1	4885489Y01	R4307M1	0613952R66
D3160M1	4813978C02	R4309M1	NOT PLACED
D3161M1	4813978C02	R4310M1	0613952R66
E0000M2	24012107027	R4311M1	0613952R66
E0001M2	24012107027	R4312M1	0613952R66
E0002M2	NOT PLACED	R4313M1	NOT PLACED
E0003M2	24012107027	R4314M1	0613952R66
E0004M2	24012107027	R4315M1	0613952R66
E0005M2	24012107027	R4316M1	0613952R66
E0006M2	24012107027	R4317M1	0613952R66
E0007M2	24012107027	RT0900M5	0615585H01
E0008M2	24012107027	SH0000M2	26012095001
E0009M2	24012107027	SH0001M2	26012095001

Circuit Ref.	Motorola Soutions Part No.	Circuit Ref.	Motorola Soutions Part No.
E0010M2	24012107027	SH0002M2	26012097001
E0300M7	24012107027	SH0003M2	26012094001
E0301M7	24012107027	SH0004M2	26012094001
E0401M4	24012107027	SH0200M7	26012095001
E0402M4	24012107027	SH0300M7	26012231001
E0403M4	24012107027	SH0400M4	26012096001
E0404M4	24012107027	SH0401M4	26012096001
E0500M3	24012107027	SH0402M4	26012098001
E0700M5	24012102001	SH0403M4	26012098001
E0701M5	24012102001	SH0500M3	26012098001
E0703M5	24012102001	SH0700M5	26012100001
E1000M1	7686949J15	SH0900M5	2686425Z02
E1001M1	7686949J15	SH0901M5	2686425Z02
E1002M1	7686949J15	SH3100M1	NOT PLACED
E1003M1	7686949J15	SP3000M5	NOT PLACED
E1004M1	7686949J15	SP3001M5	NOT PLACED
E1005M1	7686949J15	T0000M2	25012016001
E1006M1	7685268E01	T0400M4	2515121H01
E3000M5	24012102001	T0401M4	2515121H01
E3100M1	24012102001	U0000M2	51009877001
E3101M1	2485410Y02	U0001M2	5109731C48
E3102M1	2485410Y02	U0002M2	4802197J95
E3103M1	2485410Y02	U0300M7	5186310Y39
E3104M1	7686949J22	U0500M3	4802197J95
E3105M1	7686949J22	U0700M5	NOT PLACED
E3106M1	7686949J22	U0901M5	5180390L83
E3107M1	7686949J22	U0902M5	51012221001
E3108M1	7686949J22	U0903M5	5115022H01
E3109M1	7686949J22	U0904M5	5109731C48
E3110M1	7686949J22	U1000M1	5171320H01
E3111M1	7686949J22	U1001M1	51012295001
E3113M1	7686949J22	U1002M1	5189139P01
E3200M1	24012102001	U1003M1	5175772B56
E3201M1	24012102001	U1004M1	5175772B56
E3202M1	24012107027	U1005M1	5164852H47

Circuit Ref.	Motorola Soutions Part No.	Circuit Ref.	Motorola Soutions Part No.
E3203M1	24012102001	U1006M1	5185493Y01
E3204M1	24012102001	U1007M1	5189139P01
E4000M1	24012107027	U1008M1	5189139P01
E4001M1	7688697V05	U1009M1	5115001H02
E4002M1	24012107027	U1010M1	5171320H01
E4003M1	NOT PLACED	U2000M1	MM000157A01
E4004M1	24012102001	U2001M1	MM000129A01
E4005M1	2485410Y02	U3000M5	5116525H01
E4100M1	7686949J14	U3001M5	4813973M07
E4101M1	24012107027	U3002M5	51012133001
E4102M1	NOT PLACED	U3100M1	0104039J08
E4103M1	NOT PLACED	U3101M1	5114014A01
E4104M1	NOT PLACED	U3102M1	51012069001
E4200M1	24012107027	U3103M1	51012142001
E4201M1	24012107027	U3104M1	5171590Y73
E4202M1	24012107027	U3105M1	5114610F01
E4300M1	24012107027	U3106M1	51012140001
E4405M1	24012107027	U3107M1	51012140001
E4406M1	7686949J22	U3108M1	51012138001
E4407M1	7686949J22	U3109M1	5164015H94
E4408M1	24012107027	U3110M1	51012208001
E4409M1	24012102001	U3111M1	5188690V02
F4000M1	65012019001	U3112M1	5114004A35
FL0500M3	9180022M11	U3113M1	5188690V02
FL4000M1	24012038001	U3114M1	NOT PLACED
FL4001M1	24012038001	U3115M1	5185937Y01
J4000M1	0915767H01	U3200M1	51009415001
J4001M1	0915556H01	U3201M1	5114016A18
J4100M1	0916017H01	U3204M1	51009509001
J4200M1	09012053001	U3205M1	5114016A18
J4400M1	09012053001	U4000M1	51012082001
L0000M2	24012154001	U4001M1	51012082001
L0001M2	24667008031	U4100M1	5189139P01
L0002M2	24667000031	U4200M1	NOT PLACED
L0003M2	24667008031	U4201M1	NOT PLACED

Circuit Ref.	Motorola Soutions Part No.	Circuit Ref.	Motorola Soutions Part No.
L0004M2	24009343004	U4300M1	51012082001
L0005M2	24667008021	U4301M1	51012082001
L0200M7	24667000031	VR0001M2	4815096H01
L0201M7	24667000031	VR0200M7	48012260001
L0202M7	2416077H14	VR0201M7	4805656W87
L0203M7	24009344123	VR0202M7	4815002H03
L0204M7	24667005040	VR0203M7	4805656W87
L0205M7	24667000031	VR0205M7	4805656W87
L0206M7	24667005040	VR0206M7	48012260001
L0207M7	24667000031	VR0207M7	4805656W87
L0208M7	24667000031	VR0208M7	4815002H03
L0209M7	24667000031	VR0209M7	4805656W87
L0210M7	24009342045	VR0400M4	4805656W87
L0211M7	2414015C11	VR0401M4	4805656W87
L0300M7	24667008018	VR0402M4	4805656W87
L0301M7	24667008031	VR0403M4	4805656W87
L0302M7	24667008031	VR0404M4	4805656W87
L0303M7	24667008013	VR0405M4	4805656W87
L0304M7	24667008019	VR0406M4	4805656W87
L0305M7	24667008016	VR0407M4	4805656W87
L0306M7	24667008025	VR3000M5	48012202001
L0307M7	24667008031	VR3002M5	4813977M10
L0308M7	24667008024	VR3103M1	48012095001
L0401M4	24009343017	VR3104M1	48012095002
L0402M4	24009344115	VR3105M1	4813977M10
L0403M4	24667000031	VR3200M1	48012049001
L0404M4	24009344114	VR3201M1	4813977A48
L0405M4	24009344127	VR3202M1	4813977A48
L0406M4	24009343017	VR4000M1	4813977M13
L0407M4	24009343017	VR4001M1	4813977A48
L0408M4	24667000031	VR4002M1	48012153001
L0409M4	24667000031	VR4100M1	4813977A48
L0410M4	24009344127	VR4101M1	4813977A48
L0411M4	24009343017	VR4102M1	4813977A48
L0414M4	24009344113	VR4103M1	4813977A48

Circuit Ref.	Motorola Soutions Part No.	Circuit Ref.	Motorola Soutions Part No.
L0415M4	24009344114	VR4104M1	48012049001
L0416M4	NOT PLACED	VR4105M1	4813977M13
L0417M4	24009344115	VR4106M1	4813977A48
L0418M4	NOT PLACED	VR4107M1	4813977A48
L0421M4	24009344115	VR4108M1	4813977A48
L0424M4	24009344115	VR4109M1	4813977A50
L0428M4	24009344113	VR4110M1	4815040H01
L0434M4	24667008028	VR4111M1	48012153001
L0462M4	24667000031	Y0000M2	4875185M05
L0463M4	24667000031	-	-



NOTICE: The suffix "M1", "M2", and so on from the Circuit Ref. is removed from the schematic and overlays.

8.3.1.3

Circuit Board and Schematic Diagrams for 84012734002-B

Figure 140: Main Board Top Side PCB No. 84012734002-B

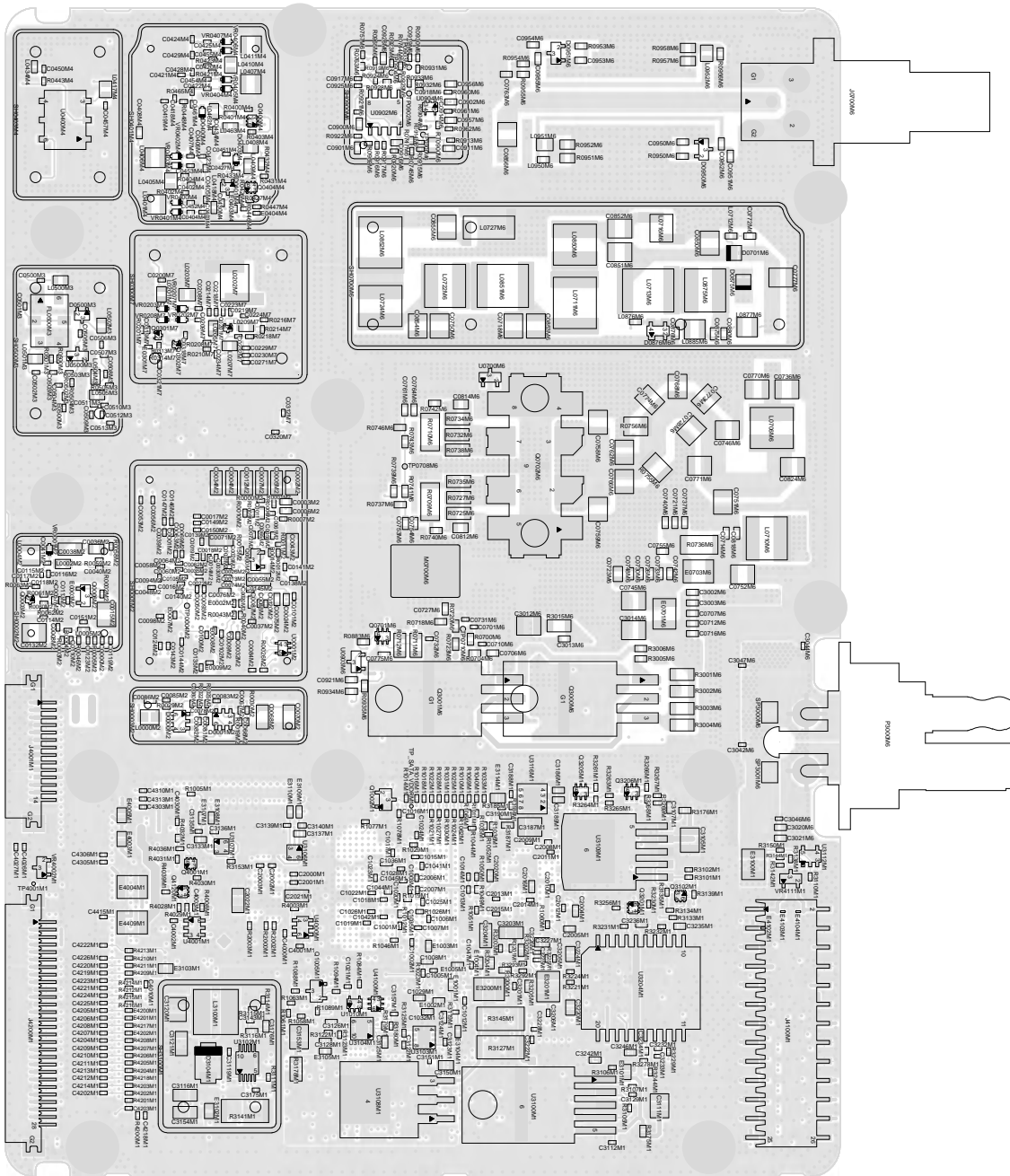

Figure 141: Main Board Bottom Side PCB No. 84012734002-B

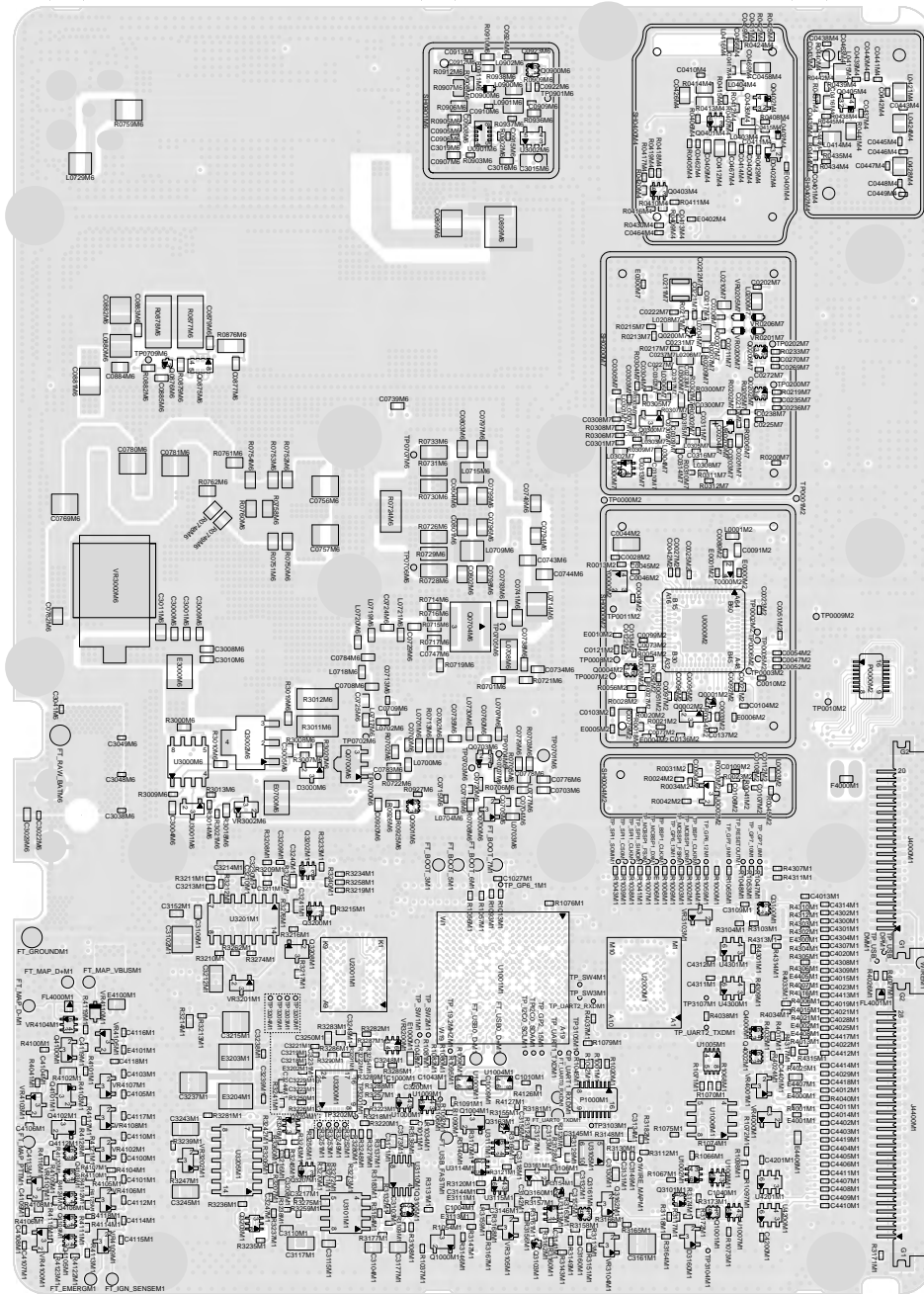

Figure 142: Overall Schematic Diagram

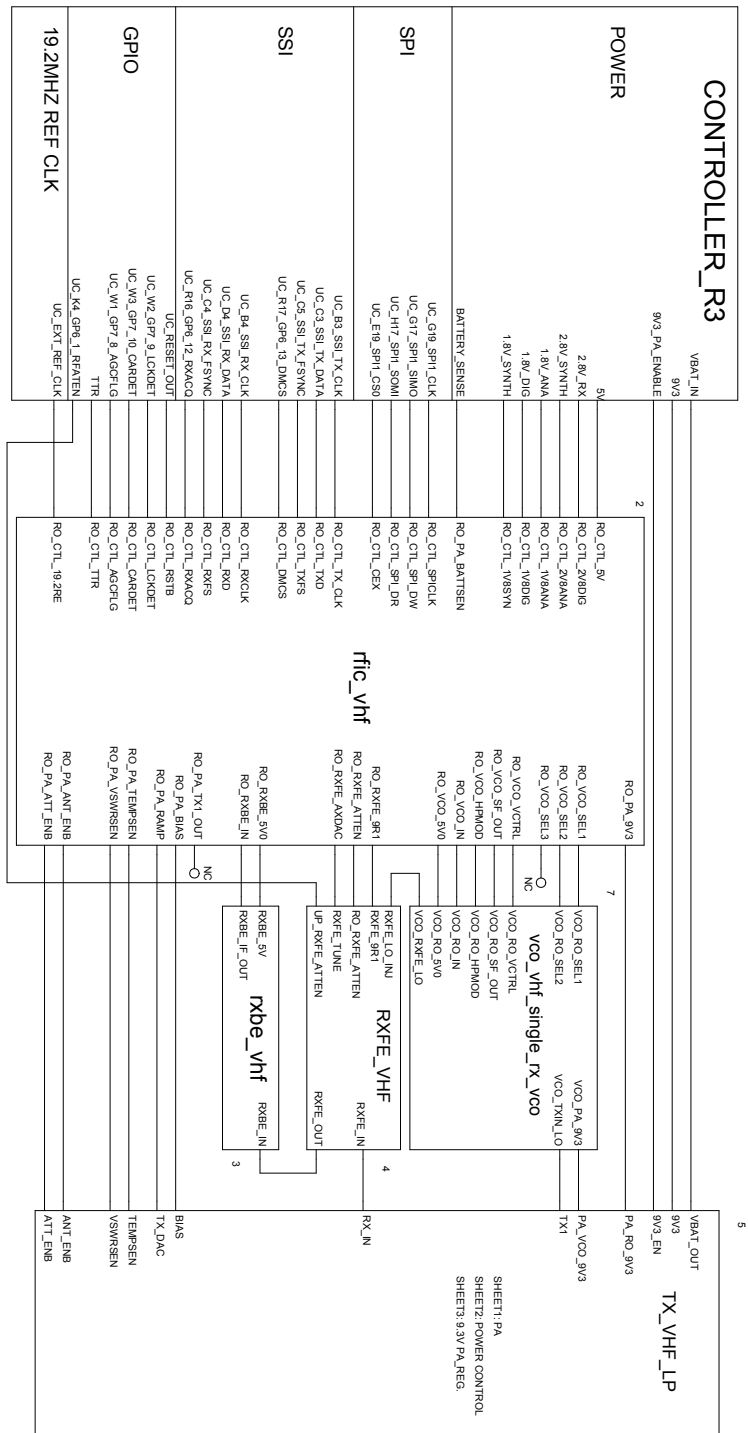

Figure 143: Receiver Front End Schematic Diagram

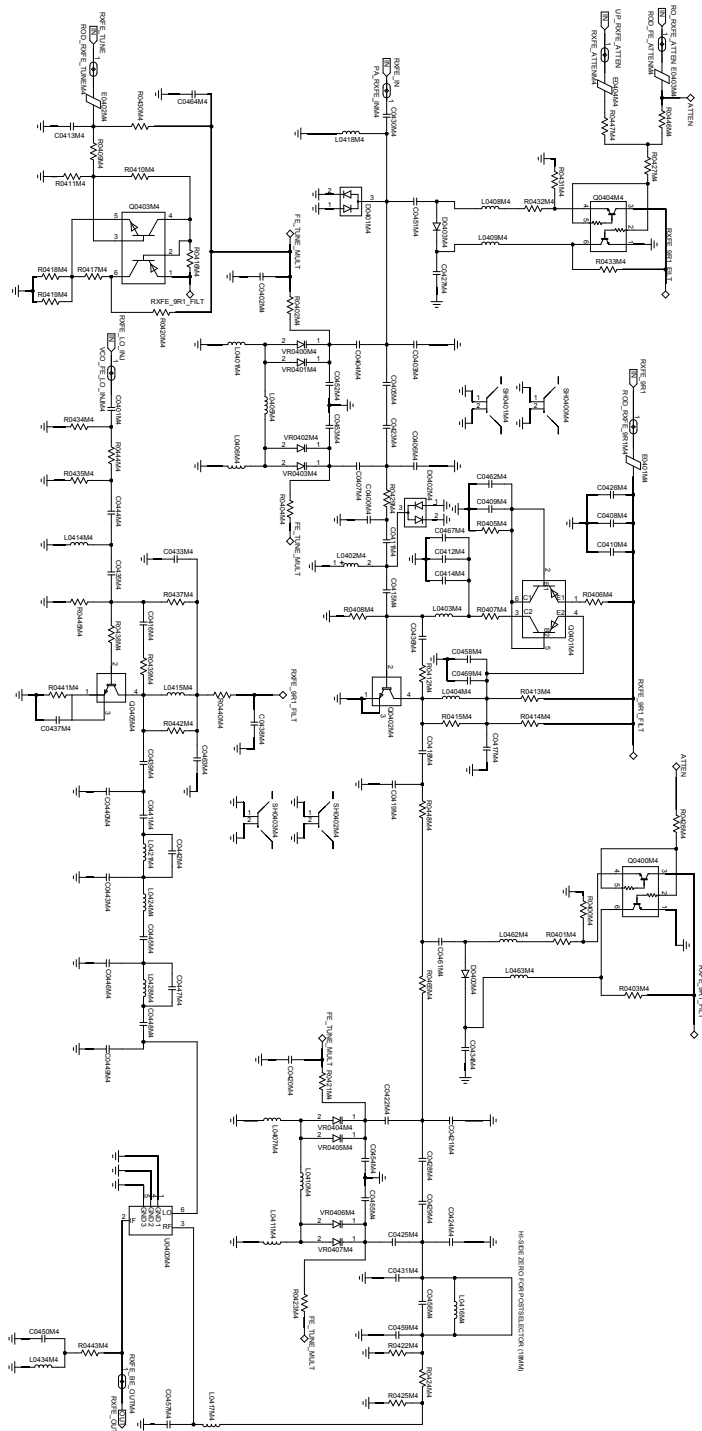

Figure 144: Receiver IF Amp Schematic Diagram

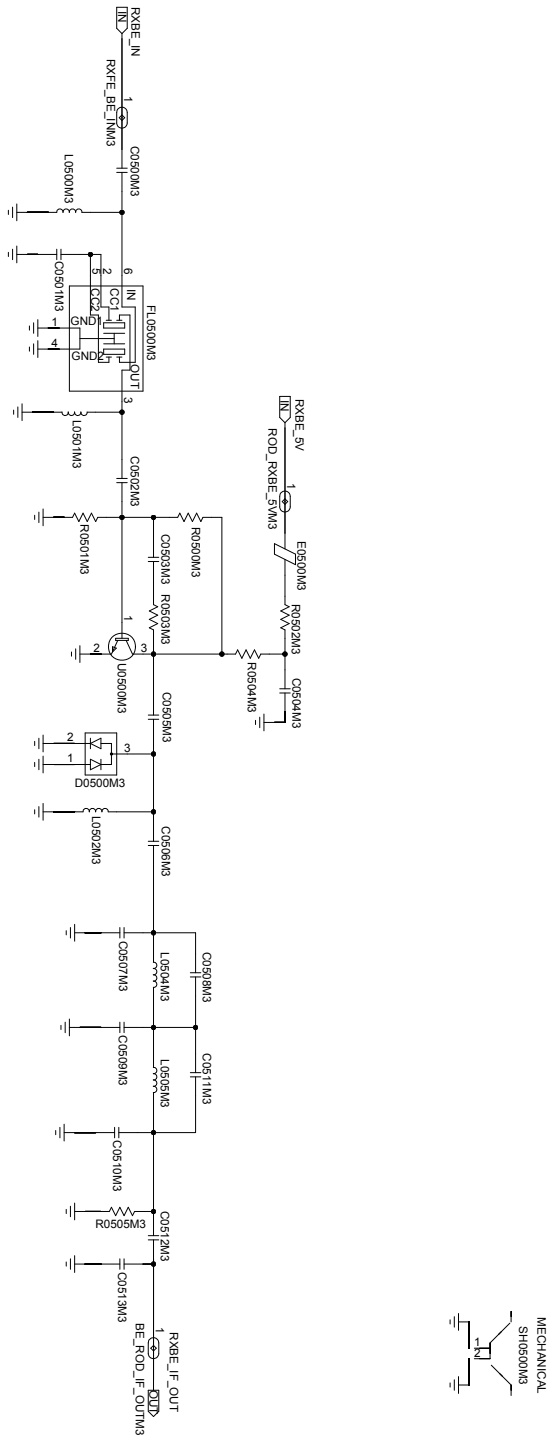

Figure 145: Transmitter Power Amplifier Schematic Diagram

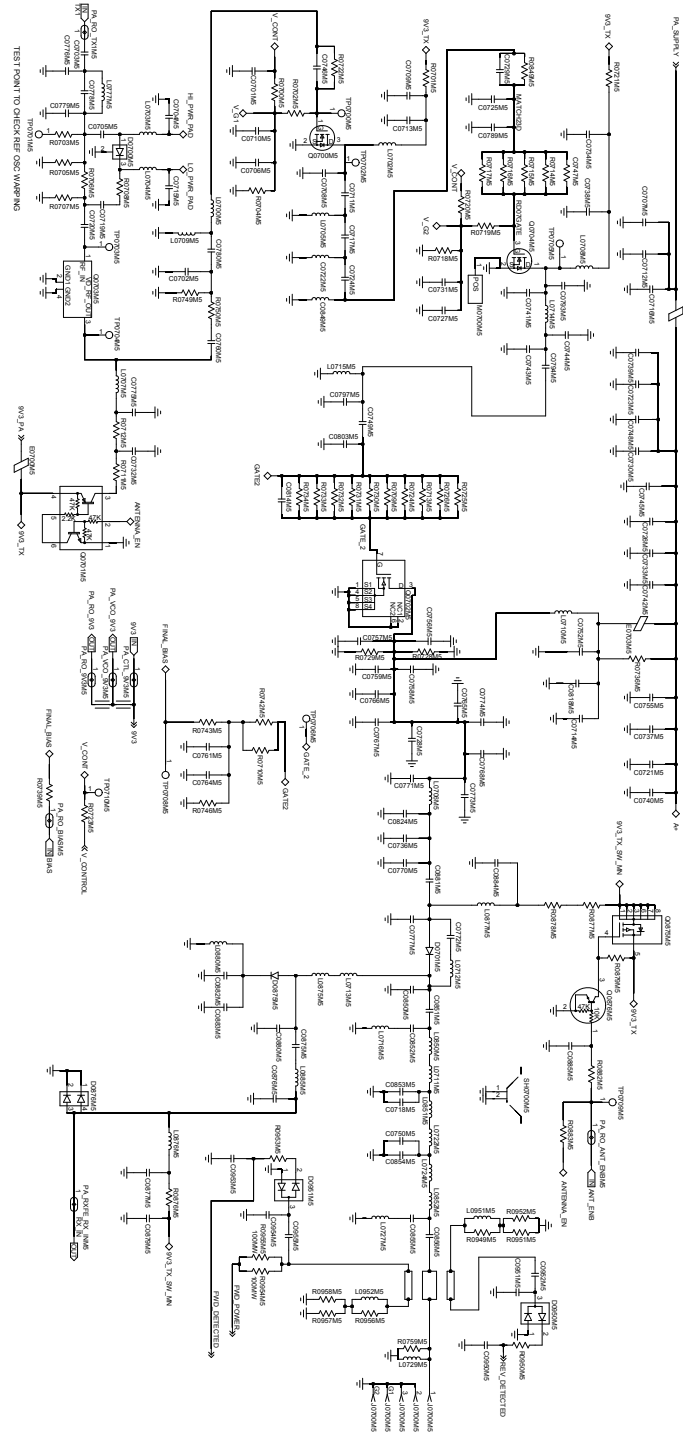
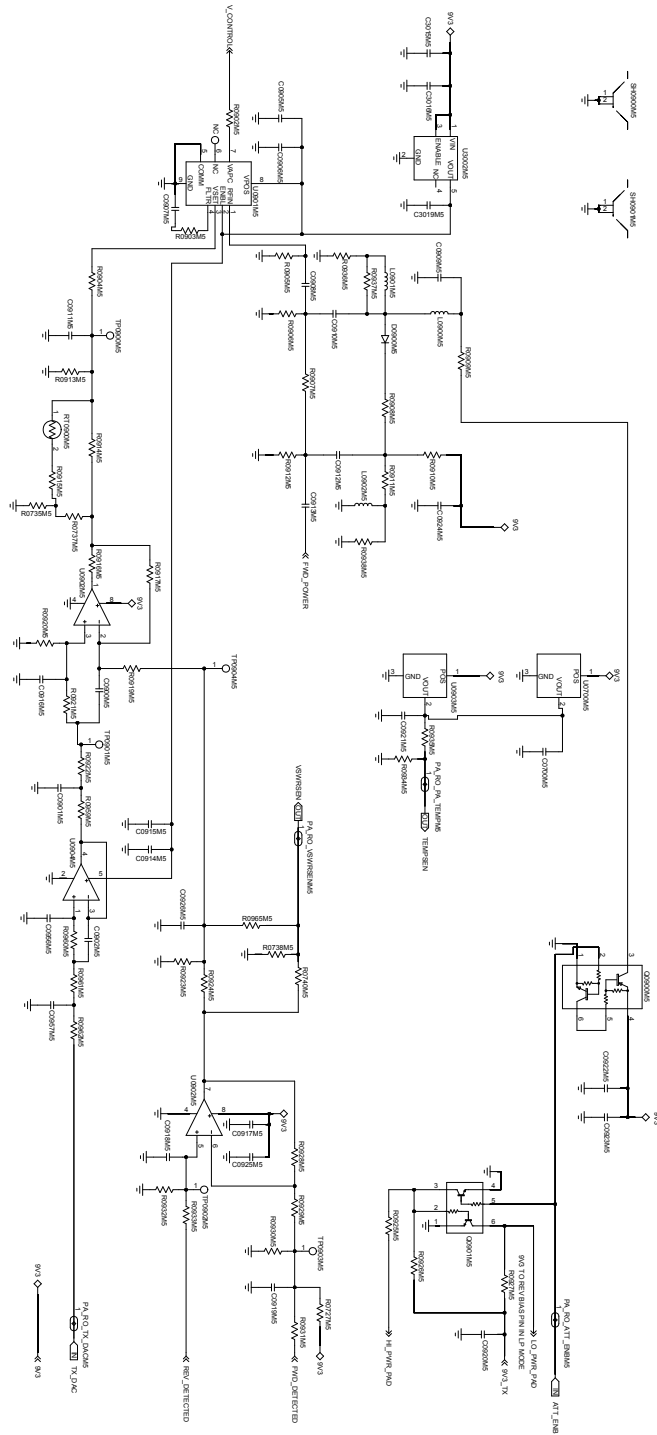

Figure 146: Power Control Schematic Diagram



NOTE VOLTAGE SHOWN FOR ANALOG TX MODE

Figure 147: Transmitter Power Amplifier DC Distribution Schematic Diagram

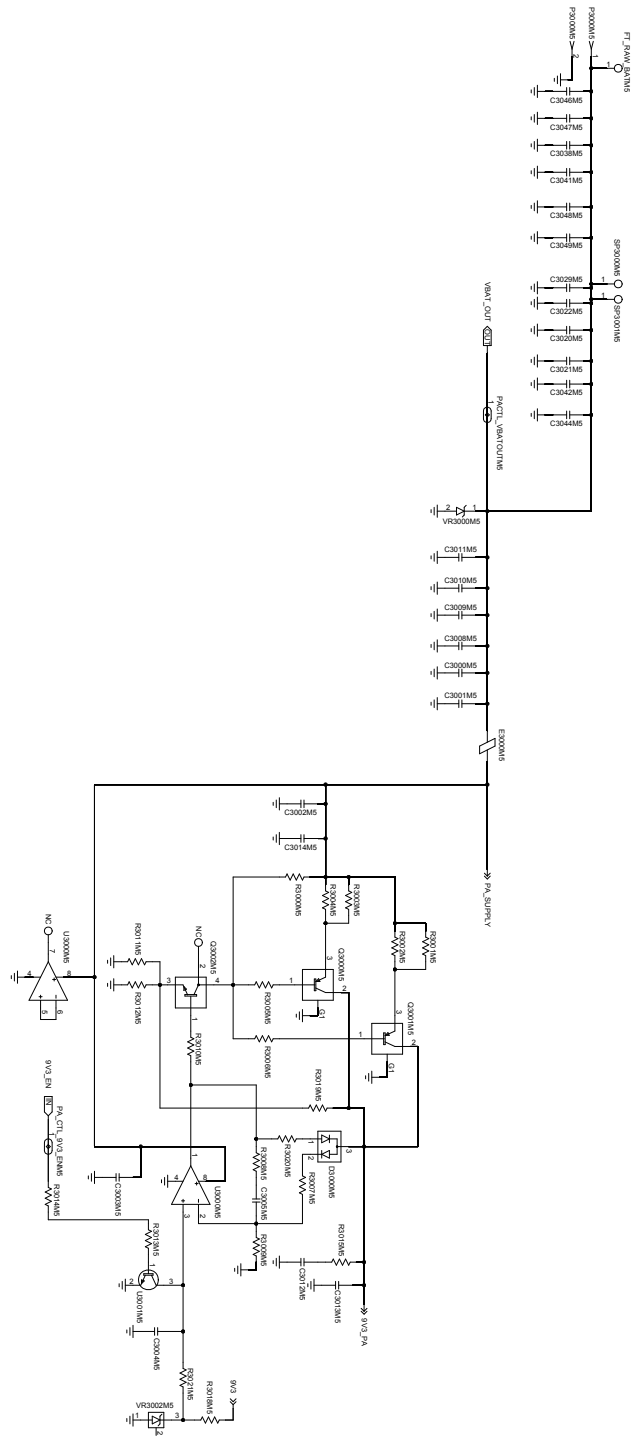

Figure 148: RFIC Schematic Diagram

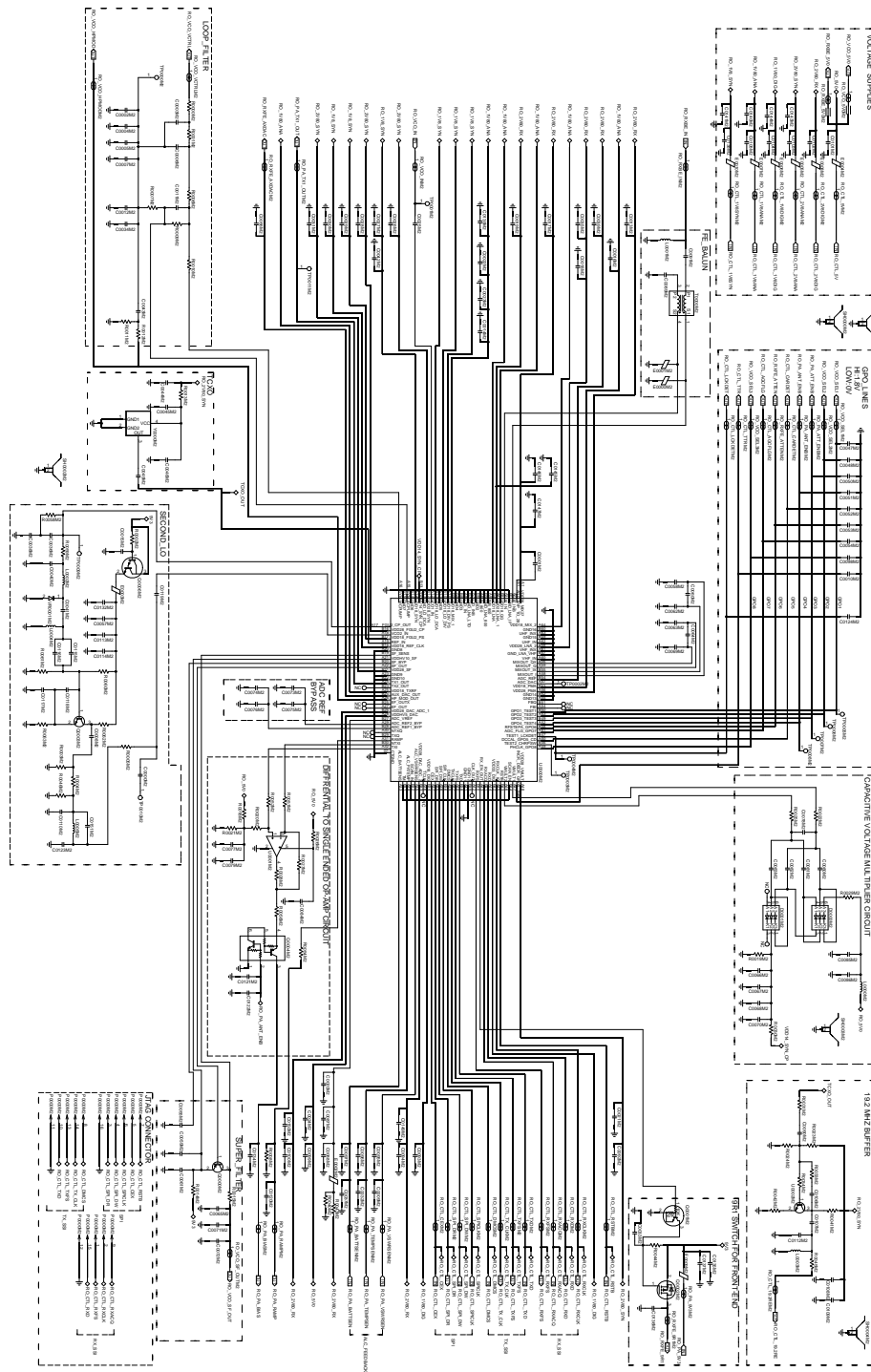

Figure 149: Receiver VCO Schematic Diagram

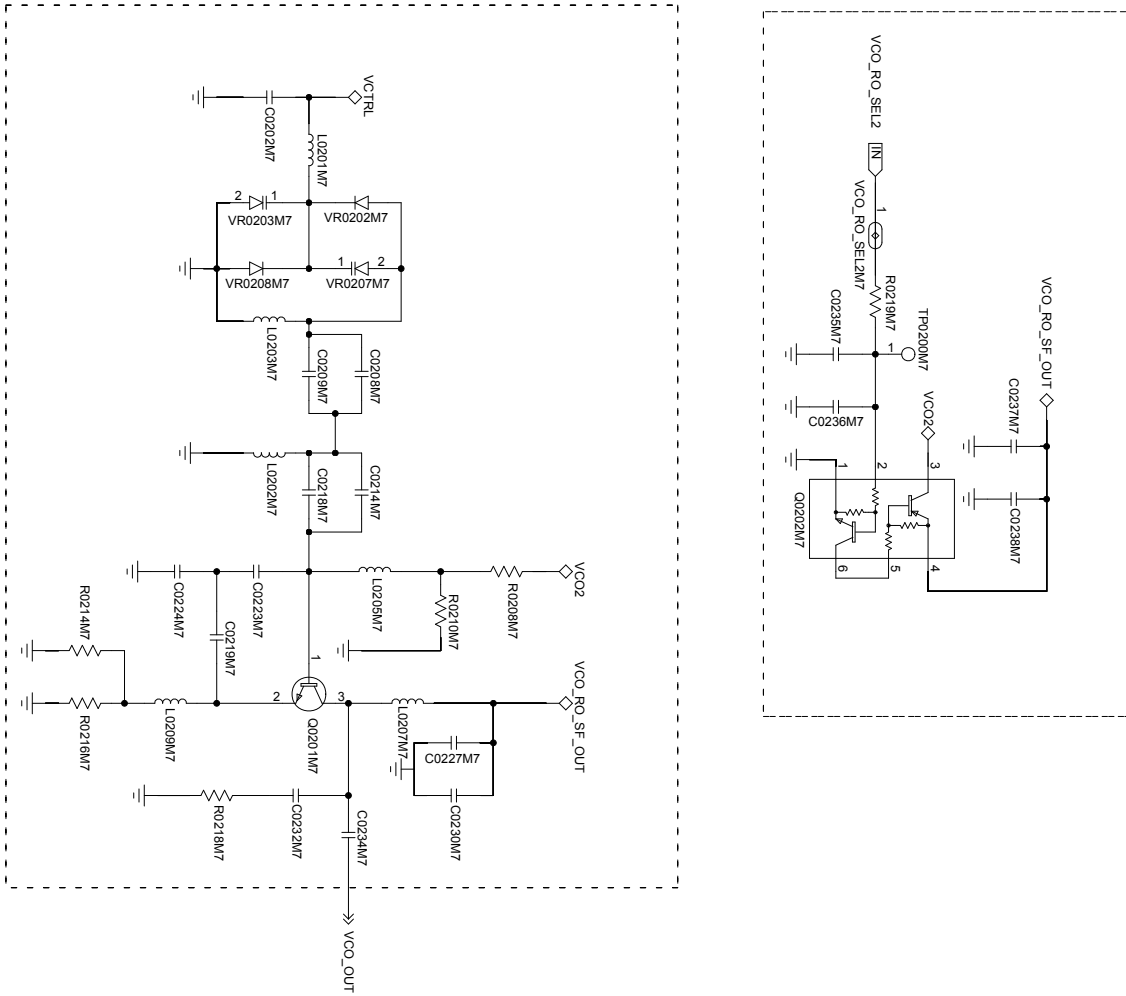

Figure 150: Transmit VCO Schematic Diagram

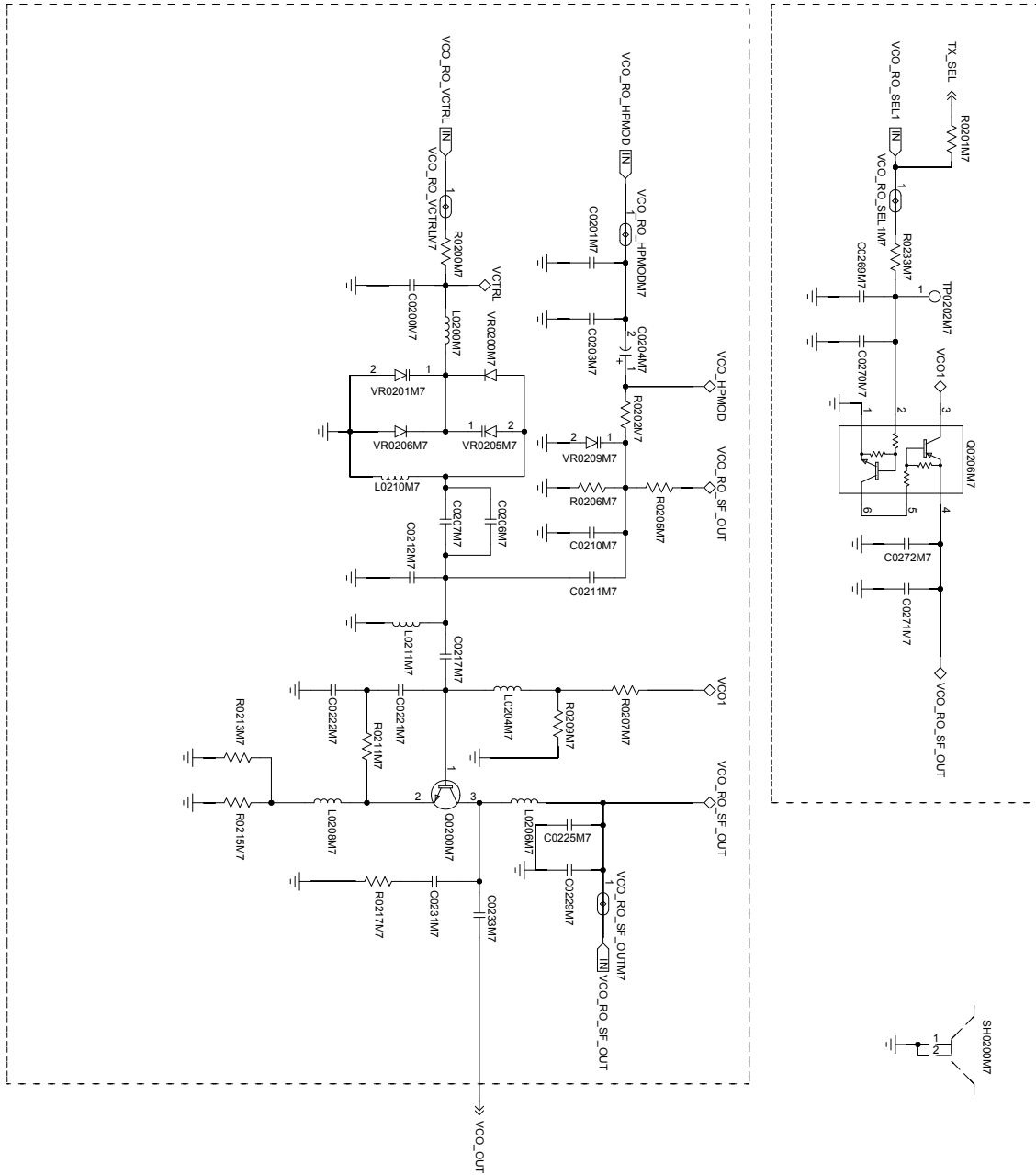
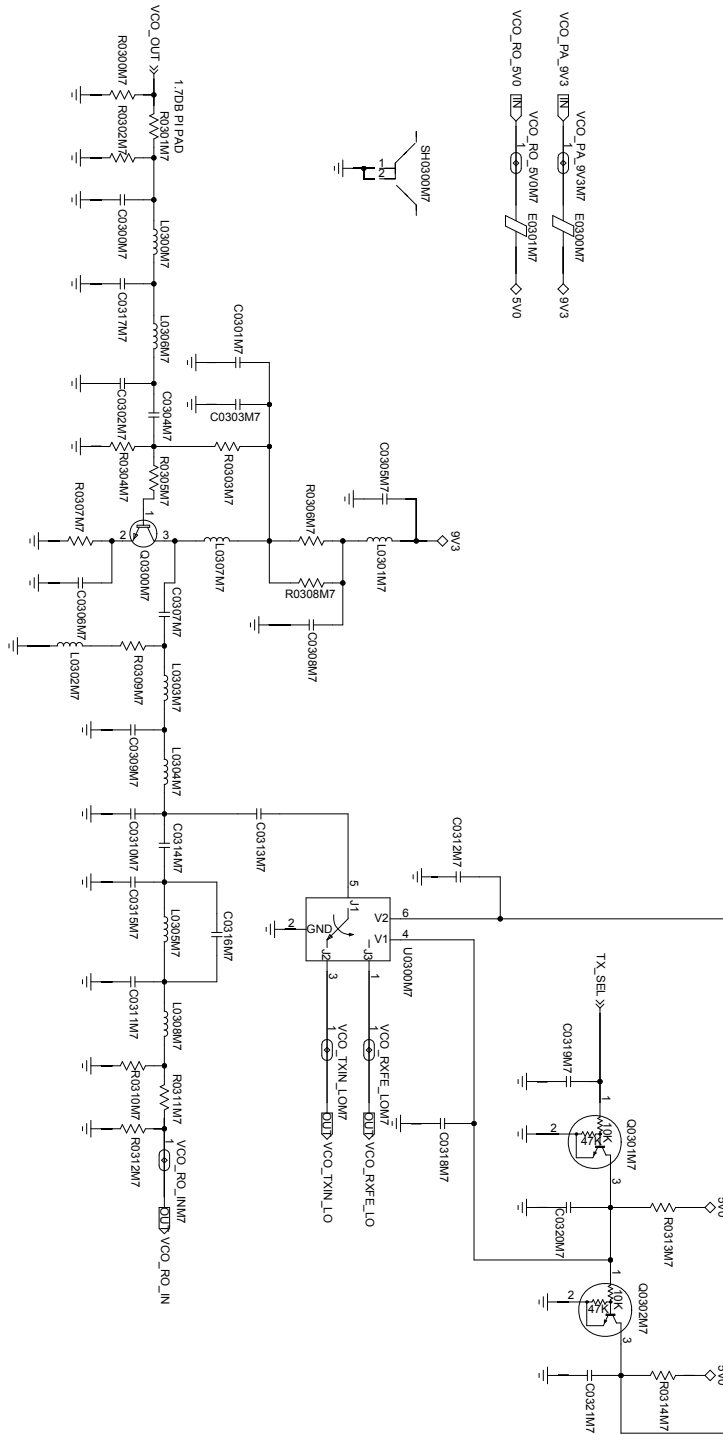

Figure 151: VCO Buffer Schematic Diagram



8.3.1.4

Parts List for 84012734002-B

Table 18: VHF Radio Parts List

Circuit Ref.	Motorola Solutions Part No.	Circuit Ref.	Motorola Solutions Part No.
C0000M2	21667009311	E0004M2	24012107027
C0001M2	21667009170	E0005M2	24012107027
C0002M2	21012044001	E0006M2	24012107027
C0003M2	NOT PLACED	E0007M2	24012107027
C0004M2	21012044001	E0008M2	24012107027
C0005M2	21012044001	E0009M2	24012107027
C0006M2	2113945C31	E0010M2	24012107027
C0007M2	21012044001	E0300M7	24012107027
C0008M2	21667009355	E0301M7	24012107027
C0009M2	21667009166	E0401M4	24012107027
C0010M2	2113945A10	E0402M4	24012107027
C0011M2	2113945C31	E0403M4	24012107027
C0012M2	21012044001	E0404M4	24012107027
C0013M2	2113945Y02	E0500M3	24012107027
C0014M2	2113945Y02	E0700M5	24012102001
C0015M2	2113946J03	E0701M5	24012102001
C0016M2	2113945A10	E0703M5	24012102001
C0017M2	2113945Y02	E3000M5	24012102001
C0018M2	2113945A10	FL0500M3	9180022M11
C0019M2	2113945Y02	J0700M5	09009348002
C0020M2	2113945A10	L0000M2	24012154001
C0021M2	2113945Y02	L0001M2	24667008031
C0022M2	2113945Y02	L0002M2	24667000031
C0023M2	2113945Y02	L0003M2	24667008031
C0024M2	21012102001	L0004M2	24009343004
C0025M2	2113945A10	L0005M2	24667008021
C0026M2	21667009174	L0200M7	24667000031
C0027M2	2113945Y02	L0201M7	24667000031
C0028M2	2113945Y02	L0202M7	2416077H14
C0029M2	2113945A10	L0203M7	24009344123
C0030M2	2113945A10	L0204M7	24667005040
C0031M2	2113945Y02	L0205M7	24667000031

Circuit Ref.	Motorola Solutions Part No.	Circuit Ref.	Motorola Solutions Part No.
C0032M2	21667009166	L0206M7	24667005040
C0033M2	NOT PLACED	L0207M7	24667000031
C0034M2	21012044001	L0208M7	24667000031
C0035M2	2113945A10	L0209M7	24667000031
C0036M2	21012044004	L0210M7	24009342045
C0037M2	21667009166	L0211M7	2414015C11
C0038M2	21012044001	L0300M7	24667008018
C0039M2	2113945Y02	L0301M7	24667008031
C0040M2	2113945A10	L0302M7	24667008031
C0041M2	21667009366	L0303M7	24667008013
C0042M2	21667009166	L0304M7	24667008019
C0043M2	21012044001	L0305M7	24667008016
C0044M2	2113955D45	L0306M7	24667008025
C0045M2	2113945Y02	L0307M7	24667008031
C0046M2	21667009166	L0308M7	24667008024
C0047M2	2113945A10	L0401M4	24009343017
C0048M2	2113945A10	L0402M4	2475122C33
C0049M2	2113945B02	L0403M4	24667000031
C0050M2	2113945A10	L0404M4	24667005043
C0051M2	2113945A10	L0405M4	24009344127
C0052M2	2113945A10	L0406M4	24009343017
C0053M2	2113945A10	L0407M4	24009343017
C0054M2	2113945A10	L0408M4	24667000031
C0055M2	2113955D37	L0409M4	24667000031
C0056M2	2113945Y02	L0410M4	24009344127
C0057M2	2113945B02	L0411M4	24009343017
C0058M2	NOT PLACED	L0414M4	24009344113
C0059M2	21667009166	L0415M4	24009344114
C0060M2	2113945A69	L0416M4	NOT PLACED
C0061M2	2113945Y02	L0417M4	24009344110
C0062M2	NOT PLACED	L0418M4	NOT PLACED
C0063M2	NOT PLACED	L0421M4	24009344115
C0064M2	2113945A69	L0424M4	24009344115
C0065M2	2113945Y02	L0428M4	24009344113
C0066M2	2113945B02	L0434M4	24667008028

Circuit Ref.	Motorola Solutions Part No.	Circuit Ref.	Motorola Solutions Part No.
C0067M2	2113945Y02	L0462M4	24667000031
C0068M2	2113955D37	L0463M4	24667000031
C0069M2	NOT PLACED	L0500M3	24667005045
C0070M2	2113955D37	L0501M3	NOT PLACED
C0071M2	2113955D37	L0502M3	24667000031
C0072M2	21667009166	L0504M3	24667000031
C0073M2	21667009166	L0505M3	24667000031
C0074M2	21667009166	L0700M5	24667008020
C0075M2	2113946S35	L0702M5	24667008028
C0076M2	2113946S35	L0703M5	24667008031
C0077M2	21667009166	L0704M5	24667008031
C0078M2	21667009372	L0705M5	24667008025
C0079M2	2113955D37	L0706M5	2485873L01
C0080M2	2113945B02	L0707M5	24667008031
C0081M2	2113945B02	L0708M5	2479990G01
C0082M2	2113945B02	L0709M5	24667008022
C0083M2	2113945B02	L0710M5	2485873L01
C0084M2	21667009166	L0711M5	2485873L02
C0085M2	2113945A10	L0712M5	NOT PLACED
C0086M2	2113945C31	L0713M5	2485873L02
C0087M2	2113946S35	L0714M5	2460591B73
C0088M2	2113945Y02	L0715M5	2460591A77
C0089M2	2113945Y02	L0716M5	2415385H05
C0090M2	2113945B02	L0722M5	2485873L01
C0091M2	2113944C45	L0724M5	2485873L01
C0092M2	2113945A10	L0727M5	2415385H08
C0093M2	2113945Y02	L0729M5	2414032B60
C0094M2	2113945Y02	L0777M5	24667008020
C0095M2	2113945A13	L0850M5	2485873L01
C0096M2	2113945B02	L0851M5	2485873L02
C0097M2	2113945B02	L0852M5	2485873L02
C0098M2	2113945A10	L0875M5	2485873L01
C0099M2	2113945Y02	L0876M5	24667008031
C0100M2	2113945Y02	L0877M5	24009343030
C0101M2	2113945A10	L0880M5	24009343030

Circuit Ref.	Motorola Solutions Part No.	Circuit Ref.	Motorola Solutions Part No.
C0102M2	2113945A10	L0885M5	2414032B49
C0103M2	2113945A10	L0900M5	24667000031
C0104M2	2113945A10	L0901M5	NOT PLACED
C0105M2	2113945A10	L0902M5	NOT PLACED
C0106M2	2113945B02	L0951M5	NOT PLACED
C0107M2	2113945B02	L0952M5	NOT PLACED
C0108M2	2113945A10	M0700M5	2686201B02
C0109M2	2113945Y02	P0000M2	NOT PLACED
C0110M2	21667009381	P3000M5	9009344001
C0112M2	21667009166	Q0000M2	4813973A13
C0113M2	2113945A10	Q0001M2	48009494001
C0114M2	2113945Y02	Q0002M2	4813970A59
C0115M2	21667009372	Q0003M2	4885316E32
C0116M2	NOT PLACED	Q0004M2	4815272H01
C0117M2	21667009388	Q0006M2	4813973A04
C0118M2	21667009378	Q0200M7	4885316E32
C0119M2	2113945A10	Q0201M7	4885316E32
C0120M2	2113945A10	Q0202M7	4815272H01
C0121M2	NOT PLACED	Q0206M7	4815272H01
C0122M2	21667009166	Q0300M7	4802197J95
C0123M2	21667009381	Q0301M7	48009494001
C0124M2	21667009166	Q0302M7	48009494001
C0132M2	2113946J03	Q0400M4	4815271H01
C0134M2	2113945A10	Q0401M4	4815267H01
C0135M2	21667009166	Q0402M4	48012201001
C0136M2	21667009166	Q0403M4	4815270H01
C0137M2	2113945Y02	Q0404M4	4815271H01
C0138M2	2113945A10	Q0405M4	48012201001
C0139M2	2113945A10	Q0700M5	CR001114A01
C0140M2	2113945Y02	Q0701M5	4816013H01
C0141M2	2113945Y02	Q0702M5	CR001117A01
C0143M2	2113945Y02	Q0703M5	4802246J29
C0144M2	2113945Y02	Q0704M5	CR001116A01
C0145M2	21667009166	Q0875M5	4813970A62
C0146M2	2113945A10	Q0876M5	48009494001

Circuit Ref.	Motorola Solutions Part No.	Circuit Ref.	Motorola Solutions Part No.
C0147M2	2113945A10	Q0900M5	4815272H01
C0149M2	2113945A10	Q0901M5	4815271H01
C0150M2	2113945A10	Q3000M5	0105959T72
C0151M2	21667009372	Q3001M5	0105959T72
C0200M7	2113945A10	Q3002M5	4813973B01
C0201M7	NOT PLACED	R0000M2	0613952R66
C0202M7	2113945A10	R0001M2	0613952R66
C0203M7	NOT PLACED	R0002M2	0613952Q96
C0204M7	NOT PLACED	R0003M2	0613952Q57
C0206M7	21667009355	R0004M2	0613952Q34
C0207M7	21667009355	R0005M2	0613952R66
C0208M7	21667009366	R0006M2	0613952Q25
C0209M7	21667009366	R0007M2	0613952Q51
C0210M7	21667009274	R0008M2	0613952R01
C0211M7	NOT PLACED	R0009M2	0613952Q58
C0212M7	NOT PLACED	R0010M2	0613952R66
C0214M7	21667009320	R0011M2	0613952Q35
C0217M7	21667009204	R0012M2	0613952Q81
C0218M7	21667009315	R0013M2	0613952Q35
C0219M7	2113945A04	R0014M2	0613952R66
C0221M7	21667009371	R0015M2	0613952R66
C0222M7	21667009374	R0018M2	0613952Q80
C0223M7	21667009378	R0019M2	0613952R01
C0224M7	21667009377	R0020M2	0613952R12
C0225M7	2113945Y02	R0021M2	0613952Q80
C0227M7	2113945Y02	R0022M2	0613952R66
C0229M7	2113945A10	R0023M2	0613952Q83
C0230M7	2113945A10	R0024M2	0613952Q80
C0231M7	2113945A10	R0025M2	0613952R66
C0232M7	2113945A10	R0026M2	0613952R66
C0233M7	21667009284	R0027M2	0613952R12
C0234M7	21667009284	R0028M2	0613952R66
C0235M7	2113945A10	R0029M2	0613952Q25
C0236M7	2113945Y02	R0030M2	0613952R66
C0237M7	2113945A10	R0031M2	0613952R66

Circuit Ref.	Motorola Solutions Part No.	Circuit Ref.	Motorola Solutions Part No.
C0238M7	2113945Y02	R0033M2	0613952R01
C0269M7	2113945A10	R0034M2	0613952Q57
C0270M7	2113945Y02	R0040M2	0613952Q70
C0271M7	2113945A10	R0041M2	0613952Q58
C0272M7	2113945Y02	R0042M2	0613952Q42
C0300M7	21667009378	R0043M2	0613952Q73
C0301M7	NOT PLACED	R0044M2	0613952R25
C0302M7	21667009300	R0045M2	0613952R66
C0303M7	NOT PLACED	R0046M2	0613952Q57
C0304M7	21667009392	R0051M2	0613952R01
C0305M7	2113945Y02	R0052M2	0613952R01
C0306M7	2113945A09	R0054M2	0613952M25
C0307M7	2113945A02	R0056M2	0613952R66
C0308M7	NOT PLACED	R0058M2	0613952Q81
C0309M7	21667009370	R0059M2	0613952R66
C0310M7	NOT PLACED	R0060M2	0613952Q86
C0311M7	21667009368	R0061M2	0613952Q85
C0312M7	2113945A10	R0062M2	0613952Q61
C0313M7	2113945A10	R0063M2	0613952Q64
C0314M7	21667009366	R0200M7	0613952R66
C0315M7	21667009315	R0201M7	0613952R66
C0316M7	21667009371	R0202M7	0613952R27
C0317M7	21667009377	R0205M7	0613952R07
C0318M7	2113945A10	R0206M7	0613952R05
C0319M7	2113945A10	R0207M7	0613952Q86
C0320M7	2113945A10	R0208M7	0613952Q78
C0321M7	2113945A10	R0209M7	0613952Q85
C0400M4	NOT PLACED	R0210M7	0613952Q73
C0401M4	2113945A10	R0211M7	0613952Q18
C0402M4	2113945A10	R0213M7	0613952Q67
C0403M4	21667009291	R0214M7	0613952Q67
C0404M4	21667009385	R0215M7	0613952Q67
C0405M4	21667009282	R0216M7	0613952Q67
C0406M4	21667009291	R0217M7	0613952Q49
C0407M4	21667009385	R0218M7	0613952Q49

Circuit Ref.	Motorola Solutions Part No.	Circuit Ref.	Motorola Solutions Part No.
C0408M4	2113945C31	R0219M7	0613952R66
C0409M4	2113945C31	R0233M7	0613952R66
C0410M4	2113945A10	R0300M7	0613952Q66
C0411M4	2113945A10	R0301M7	0613952Q25
C0412M4	2113946F05	R0302M7	0613952Q66
C0413M4	21667009166	R0303M7	0613952Q94
C0414M4	2113945A10	R0304M7	0613952Q89
C0415M4	21667009376	R0305M7	0613952Q32
C0416M4	2113945C31	R0306M7	0613952Q49
C0417M4	2113945A10	R0307M7	0613952H46
C0418M4	2113945A10	R0308M7	0613952Q49
C0419M4	21667009315	R0309M7	0613952Q42
C0420M4	2113945A10	R0310M7	0613952Q39
C0421M4	21667009291	R0311M7	0613952R66
C0422M4	21667009385	R0312M7	NOT PLACED
C0423M4	21667009282	R0313M7	0613952Q73
C0424M4	21667009291	R0314M7	0613952Q73
C0425M4	21667009385	R0400M4	0613952R01
C0426M4	2113946F05	R0401M4	0613952H73
C0427M4	2113945A05	R0402M4	0613952R25
C0428M4	21667009282	R0403M4	0613952R01
C0429M4	21667009282	R0404M4	0613952R25
C0430M4	2113945A10	R0405M4	0613952R05
C0431M4	NOT PLACED	R0406M4	0613952Q91
C0433M4	2113945A10	R0407M4	0613952Q91
C0434M4	2113945A05	R0408M4	0613952Q88
C0435M4	21667009388	R0409M4	0613952R66
C0436M4	2113945C31	R0410M4	0613952R01
C0437M4	2113945A10	R0411M4	0613952R01
C0438M4	2113945A10	R0412M4	0613952Q67
C0439M4	21667009365	R0413M4	0613958H46
C0440M4	21667009364	R0414M4	0613958H49
C0441M4	21667009373	R0415M4	0613952Q49
C0442M4	NOT PLACED	R0416M4	0613952Q69
C0443M4	21667009373	R0417M4	0613952Q75

Circuit Ref.	Motorola Solutions Part No.	Circuit Ref.	Motorola Solutions Part No.
C0444M4	21667009388	R0418M4	0613952Q69
C0445M4	21667009375	R0419M4	0613952Q69
C0446M4	21667009372	R0420M4	0613952R25
C0447M4	21667009303	R0421M4	0613952R25
C0448M4	21667009373	R0422M4	0613952Q53
C0449M4	21667009370	R0423M4	0613952R25
C0450M4	21667009386	R0424M4	0613952Q39
C0451M4	2113945A10	R0425M4	0613952Q53
C0452M4	21667009378	R0426M4	0613952Q87
C0453M4	21667009378	R0427M4	0613952Q87
C0454M4	21667009378	R0429M4	0613952R66
C0455M4	21667009378	R0430M4	NOT PLACED
C0456M4	2113945A10	R0431M4	0613952R01
C0457M4	21667009201	R0432M4	0613952H73
C0458M4	2113946F05	R0433M4	0613952R01
C0459M4	NOT PLACED	R0434M4	0613952L46
C0461M4	2113945A10	R0435M4	0613952L46
C0462M4	2113945A10	R0437M4	0613952Q80
C0463M4	2113945A10	R0438M4	0613952Q25
C0464M4	NOT PLACED	R0439M4	0613952Q69
C0467M4	2113956B21	R0440M4	0613958H41
C0469M4	2113956B21	R0441M4	0613958H41
C0500M3	21667009371	R0442M4	0613952Q83
C0501M3	21667009355	R0443M4	0613952Q33
C0502M3	2113945Y02	R0444M4	0613952K25
C0503M3	2113945Y02	R0445M4	0613952Q75
C0504M3	2113945Y02	R0446M4	NOT PLACED
C0505M3	21667009370	R0447M4	0613952R66
C0506M3	21667009371	R0448M4	0613952Q25
C0507M3	21667009307	R0465M4	0613952R66
C0508M3	21667009332	R0500M3	0613952R08
C0509M3	21667009380	R0501M3	0613952R03
C0510M3	21667009307	R0502M3	0613952Q81
C0511M3	NOT PLACED	R0503M3	0613952Q87
C0512M3	21667009390	R0504M3	0613952Q61

Circuit Ref.	Motorola Solutions Part No.	Circuit Ref.	Motorola Solutions Part No.
C0513M3	21667009378	R0505M3	NOT PLACED
C0700M5	NOT PLACED	R0700M5	0613952J01
C0701M5	21667009174	R0701M5	0613952G67
C0702M5	2113944C34	R0702M5	0613952H49
C0703M5	2113944C51	R0703M5	0613952J01
C0704M5	21667009174	R0704M5	0613952J01
C0705M5	21667009174	R0705M5	0613952H48
C0706M5	NOT PLACED	R0706M5	0613952H53
C0707M5	2113945C31	R0707M5	0613952H48
C0708M5	21667011438	R0708M5	0613952H46
C0709M5	2113945C04	R0709M5	0613958S49
C0710M5	21667009174	R0710M5	0613959Q42
C0711M5	2113944C06	R0711M5	0613958S49
C0712M5	2113945L49	R0712M5	0613958S49
C0713M5	21667009174	R0713M5	0613958S49
C0714M5	NOT PLACED	R0714M5	0613952H42
C0715M5	21667009174	R0715M5	0613952H42
C0716M5	2113944C51	R0716M5	0613952H42
C0717M5	2113944C35	R0717M5	0613952H42
C0718M5	NOT PLACED	R0718M5	0613952H96
C0719M5	21667009174	R0719M5	0613952H89
C0720M5	2113944C51	R0720M5	0613952J01
C0721M5	2113945L37	R0721M5	0613952G67
C0722M5	24667008018	R0722M5	NOT PLACED
C0723M5	NOT PLACED	R0723M5	0613952G67
C0724M5	2113944C84	R0724M5	0613958S49
C0725M5	NOT PLACED	R0725M5	0613958S49
C0726M5	2113944C51	R0726M5	0613958S49
C0727M5	NOT PLACED	R0727M5	NOT PLACED
C0728M5	2111078B13	R0728M5	0613958J49
C0729M5	2113944C46	R0729M5	0613958J49
C0730M5	2113945L49	R0730M5	0613958S49
C0731M5	21667009174	R0731M5	0613958S49
C0732M5	2113945A09	R0732M5	0613958S49
C0733M5	2113944C45	R0733M5	0613958S49

Circuit Ref.	Motorola Solutions Part No.	Circuit Ref.	Motorola Solutions Part No.
C0734M5	2113944C51	R0734M5	0613958S49
C0736M5	NOT PLACED	R0735M5	0613952R66
C0737M5	2113944C04	R0736M5	0613959Q25
C0738M5	2113944C46	R0737M5	NOT PLACED
C0739M5	NOT PLACED	R0738M5	0613952N43
C0740M5	2113945C25	R0739M5	0613952H73
C0741M5	NOT PLACED	R0740M5	0613952P01
C0742M5	2113944C30	R0742M5	NOT PLACED
C0743M5	NOT PLACED	R0743M5	0613952J17
C0744M5	NOT PLACED	R0746M5	0613952J25
C0745M5	21009337414	R0749M5	0613952H41
C0746M5	2113944C06	R0750M5	0613952H37
C0747M5	0613952H42	R0759M5	0613959H12
C0748M5	2113945C31	R0849M5	NOT PLACED
C0749M5	2113944F05	R0876M5	0613958S73
C0750M5	2111078B33	R0877M5	0613959Y37
C0752M5	2113944F05	R0878M5	0613959Y37
C0755M5	2113944C36	R0879M5	0613952J25
C0756M5	NOT PLACED	R0882M5	0613952G67
C0757M5	NOT PLACED	R0883M5	0613952G67
C0758M5	2111078B43	R0902M5	0613952R66
C0759M5	2111078B42	R0903M5	0613952N01
C0760M5	2113944C51	R0904M5	0613952R66
C0761M5	2113944C45	R0905M5	0613952H42
C0764M5	2113944C51	R0906M5	0613958H49
C0765M5	NOT PLACED	R0907M5	0613958H56
C0766M5	2111078B13	R0908M5	0613952H32
C0767M5	NOT PLACED	R0909M5	0613952R66
C0768M5	2111078B16	R0910M5	0613952H91
C0770M5	2111078B31	R0911M5	0613952H85
C0771M5	2111078B46	R0912M5	0613958H49
C0772M5	NOT PLACED	R0913M5	0613952M51
C0773M5	NOT PLACED	R0914M5	0613952M71
C0774M5	NOT PLACED	R0915M5	0613952Z76
C0775M5	2113944C06	R0916M5	0613952R66

Circuit Ref.	Motorola Solutions Part No.	Circuit Ref.	Motorola Solutions Part No.
C0776M5	2113944C31	R0917M5	0613952P01
C0777M5	NOT PLACED	R0919M5	0613952P01
C0778M5	21667011432	R0920M5	0613952N01
C0779M5	2113944C31	R0921M5	0613952N01
C0780M5	2113944C06	R0922M5	0613952R66
C0789M5	NOT PLACED	R0923M5	0613952M43
C0793M5	21667007045	R0924M5	0613952N01
C0794M5	21667007047	R0925M5	0613952Q59
C0797M5	NOT PLACED	R0926M5	0613952H79
C0803M5	NOT PLACED	R0927M5	0613952N01
C0814M5	2113944F67	R0928M5	0613952P30
C0818M5	NOT PLACED	R0929M5	0613952N81
C0824M5	2111078B13	R0930M5	0613952Z61
C0849M5	24667008016	R0931M5	0613952Z26
C0850M5	2111078B22	R0932M5	0613952N51
C0851M5	2111078B40	R0933M5	0613952M66
C0852M5	2111078B11	R0934M5	0613952J17
C0853M5	2111078B34	R0935M5	0613952H91
C0854M5	NOT PLACED	R0936M5	0613952H91
C0855M5	2111078B08	R0937M5	0613952R66
C0856M5	2111078B38	R0938M5	0613952R66
C0875M5	2113944C47	R0949M5	0613952G67
C0876M5	2113944C32	R0950M5	0613952G67
C0877M5	2113944C06	R0951M5	0613958H55
C0879M5	2113944C06	R0952M5	0613958H53
C0880M5	2113944C35	R0953M5	0613952G67
C0881M5	2111078B50	R0954M5	0613952H39
C0882M5	2111078B53	R0955M5	0613952H39
C0883M5	NOT PLACED	R0956M5	0613952G67
C0884M5	2113944F15	R0957M5	0613958H55
C0885M5	2113944C51	R0958M5	0613958H53
C0900M5	NOT PLACED	R0959M5	0613952R66
C0901M5	NOT PLACED	R0960M5	0613952N58
C0902M5	2113944C51	R0961M5	0613952N58
C0905M5	2113945C31	R0962M5	0613952N58

Circuit Ref.	Motorola Solutions Part No.	Circuit Ref.	Motorola Solutions Part No.
C0906M5	2113945A10	R0965M5	NOT PLACED
C0907M5	2113945L41	R3000M5	0613952H60
C0908M5	21667009174	R3001M5	0615871H01
C0909M5	21667009174	R3002M5	0615871H01
C0910M5	21667009174	R3003M5	0615871H01
C0911M5	2113944C02	R3004M5	0615871H01
C0912M5	21667009174	R3005M5	0613952H25
C0913M5	21667009174	R3006M5	0613952H25
C0914M5	21667009174	R3007M5	0613952M30
C0915M5	2113946B04	R3008M5	0613952G67
C0916M5	NOT PLACED	R3009M5	0613952M43
C0917M5	21667009174	R3010M5	0613952G67
C0918M5	21667009174	R3011M5	0613959Q60
C0919M5	21667009174	R3012M5	0613959Q60
C0920M5	2113944C51	R3013M5	0613952R01
C0921M5	2113944C51	R3014M5	0613952R01
C0922M5	2113946B04	R3015M5	0615871H01
C0923M5	2113944C51	R3018M5	0613952H73
C0924M5	21667009174	R3019M5	0613952H60
C0925M5	2113946B04	R3020M5	0613952G67
C0926M5	2113944C02	R3021M5	0613952R25
C0950M5	2113944C51	RT0900M5	0615585H01
C0951M5	2113944C30	SH0000M2	26012095001
C0952M5	2113944C51	SH0001M2	26012095001
C0953M5	2113944C51	SH0002M2	26012097001
C0954M5	2113944M27	SH0003M2	26012094001
C0955M5	2113944C51	SH0004M2	26012094001
C0956M5	2113944C01	SH0200M7	26012095001
C0957M5	2113944C49	SH0300M7	26012231001
C3000M5	2113944C38	SH0400M4	26012096001
C3001M5	2113944C06	SH0401M4	26012096001
C3002M5	2113944C06	SH0402M4	26012098001
C3003M5	2113945C31	SH0403M4	26012098001
C3004M5	2113945C02	SH0500M3	26012098001
C3005M5	2113945C02	SH0700M5	26012100001

Circuit Ref.	Motorola Solutions Part No.	Circuit Ref.	Motorola Solutions Part No.
C3008M5	2113944C51	SH0900M5	2686425Z02
C3009M5	2113945C31	SH0901M5	2686425Z02
C3010M5	2113944C46	SP3000M5	NOT PLACED
C3011M5	2113945G53	SP3001M5	NOT PLACED
C3012M5	2113946J04	T0000M2	25012016001
C3013M5	2113945C31	U0000M2	51009877001
C3014M5	21009337414	U0001M2	5109731C48
C3015M5	2113946G01	U0002M2	4802197J95
C3016M5	2113945C31	U0300M7	5186310Y39
C3019M5	2113946S35	U0400M4	HZ000490A01
C3020M5	2113945C26	U0500M3	4802197J95
C3021M5	2113944C06	U0700M5	NOT PLACED
C3022M5	2113945A10	U0901M5	5180390L83
C3029M5	NOT PLACED	U0902M5	51012221001
C3038M5	21667009169	U0903M5	5115022H01
C3041M5	21667009169	U0904M5	5109731C48
C3042M5	21667009169	U3000M5	5116525H01
C3044M5	21667009169	U3001M5	4813973M07
C3046M5	21667009174	U3002M5	51012133001
C3047M5	21667009174	VR0001M2	4815096H01
C3048M5	21667009174	VR0200M7	48012260001
C3049M5	21667009174	VR0201M7	CR000291A01
D0000M2	4815011H01	VR0202M7	4815002H03
D0001M2	4815011H01	VR0203M7	CR000291A01
D0400M4	4884800Y03	VR0205M7	CR000291A01
D0401M4	4813974A19	VR0206M7	48012260001
D0402M4	4813974A19	VR0207M7	CR000291A01
D0403M4	4884800Y03	VR0208M7	4815002H03
D0500M3	4813974A19	VR0209M7	CR000291A01
D0700M5	CR001073A01	VR0400M4	CR000291A01
D0701M5	48012160001	VR0401M4	CR000291A01
D0875M5	48012160001	VR0402M4	CR000291A01
D0876M5	4886622Y06	VR0403M4	CR000291A01
D0900M5	48012181001	VR0404M4	CR000291A01
D0950M5	4813974A21	VR0405M4	CR000291A01

Circuit Ref.	Motorola Solutions Part No.	Circuit Ref.	Motorola Solutions Part No.
D0951M5	4813974A21	VR0406M4	CR000291A01
D3000M5	4813978P07	VR0407M4	CR000291A01
E0000M2	24012107027	VR3000M5	48012202001
E0001M2	24012107027	VR3002M5	4813977M10
E0002M2	NOT PLACED	Y0000M2	4875185M05
E0003M2	24012107027	-	-

8.4

VHF High Power Service Information

8.4.1

Allocation of Schematics and Circuit Boards

This chapter shows the schematics for the VHF circuits. The PCB component layouts and the Parts List in this chapter show both the Controller and VHF circuit components.

Diagrams and Parts List for 84012736001-A

- [Figure 152: Main Board Top Side PCB No. 84012736001-A on page 266](#)
- [Figure 153: Main Board Bottom Side PCB No. 84012736001-A on page 267](#)
- [Figure 154: Overall Schematic Diagram on page 268](#)
- [Figure 155: Receiver Front-End Schematic Diagram on page 269](#)
- [Figure 156: Receiver IF Amp Schematic Diagram on page 270](#)
- [Figure 157: Transmitter Power Amplifier Schematic Diagram on page 271](#)
- [Figure 158: Power Control Schematic Diagram on page 272](#)
- [Figure 159: Transmitter Power Amplifier DC Distribution Schematic Diagram on page 273](#)
- [Figure 160: RFIC Schematic Diagram on page 274](#)
- [Figure 161: Receiver VCO Schematic Diagram on page 275](#)
- [Figure 162: Transmit VCO Schematic Diagram on page 276](#)
- [Figure 163: VCO Buffer Schematic Diagram on page 277](#)

[Parts List for 84012736001-A on page 278](#)

Diagrams and Parts List for 84012736002-B

Diagrams:

- [Figure 164: Main Board Top Side PCB No. 84012736002-B on page 303](#)
- [Figure 165: Main Board Bottom Side PCB No. 84012736002-B on page 304](#)
- [Figure 166: Overall Schematic Diagram on page 305](#)
- [Figure 167: Receiver Front End Schematic Diagram on page 306](#)
- [Figure 168: Receiver IF Amp Schematic Diagram on page 307](#)
- [Figure 169: Transmitter Power Amplifier Schematic Diagram on page 308](#)
- [Figure 170: Power Control Schematic Diagram on page 309](#)

- [Figure 171: Transmitter Power Amplifier DC Distribution Schematic Diagram on page 310](#)
 - [Figure 172: RFIC Schematic Diagram on page 311](#)
 - [Figure 173: Receiver VCO Schematic Diagram on page 312](#)
 - [Figure 174: Transmit VCO Schematic Diagram on page 313](#)
 - [Figure 175: VCO Buffer Schematic Diagram on page 314](#)
- [Parts List for 84012736002-B on page 315](#)

8.4.1.1

Circuit Board and Schematic Diagrams for 84012736001-A

Figure 152: Main Board Top Side PCB No. 84012736001-A

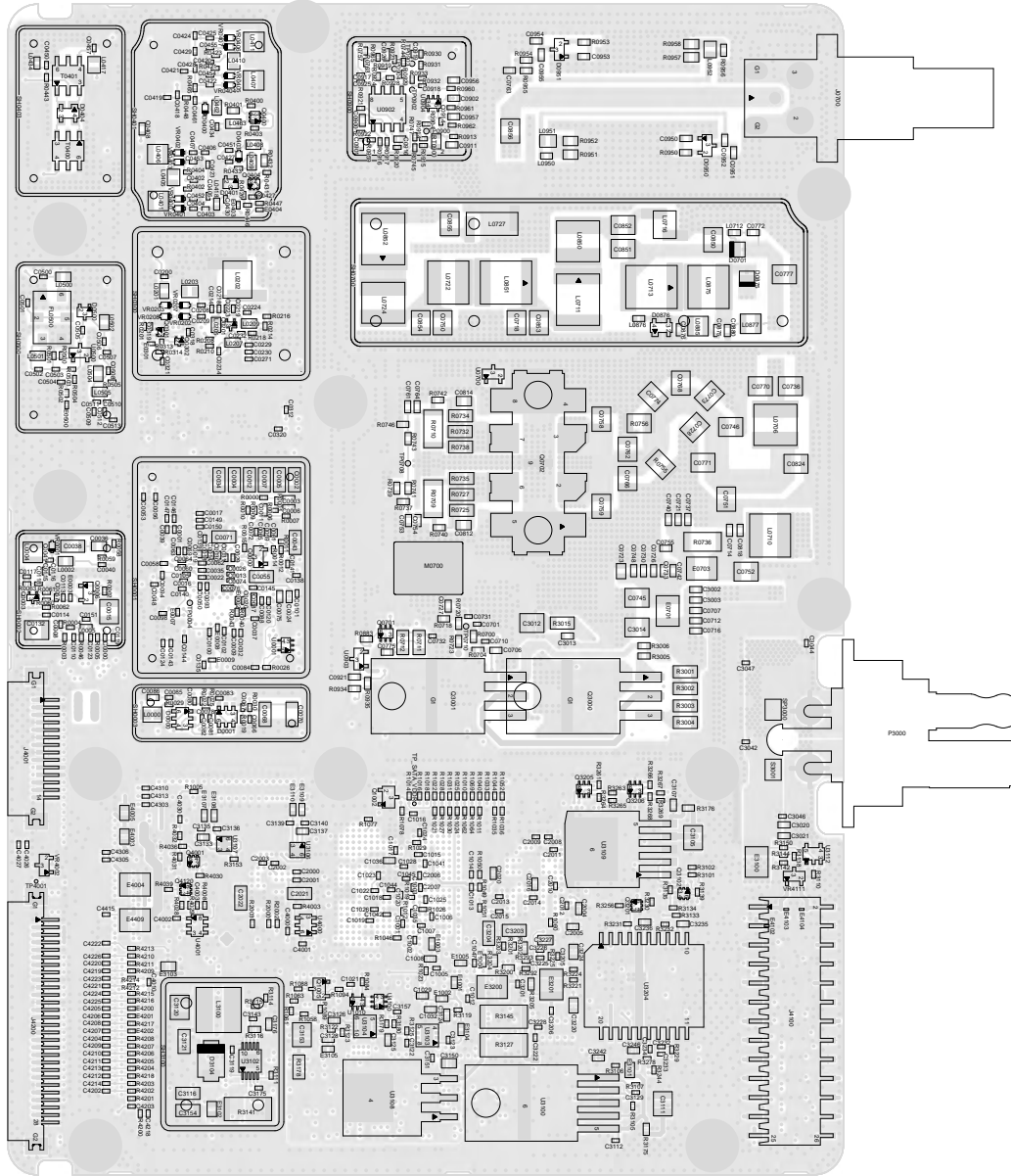

Figure 153: Main Board Bottom Side PCB No. 84012736001-A

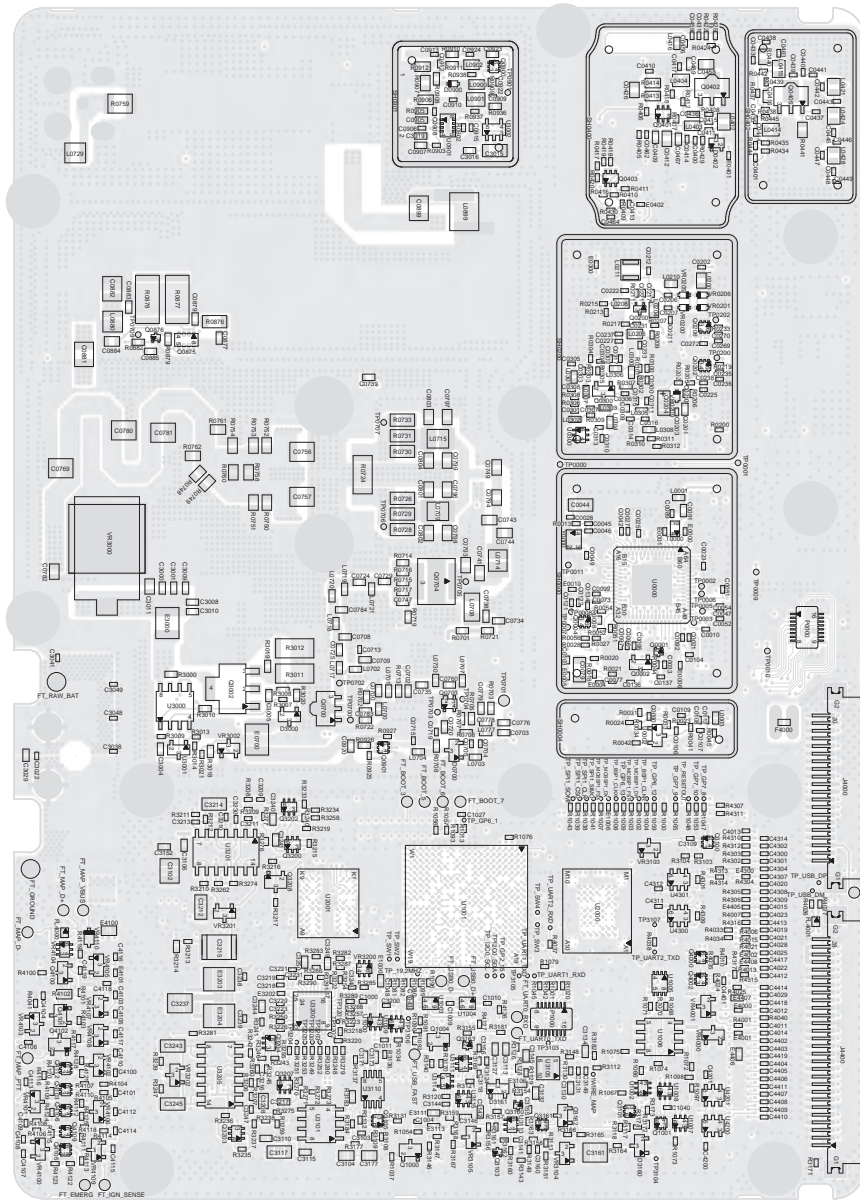
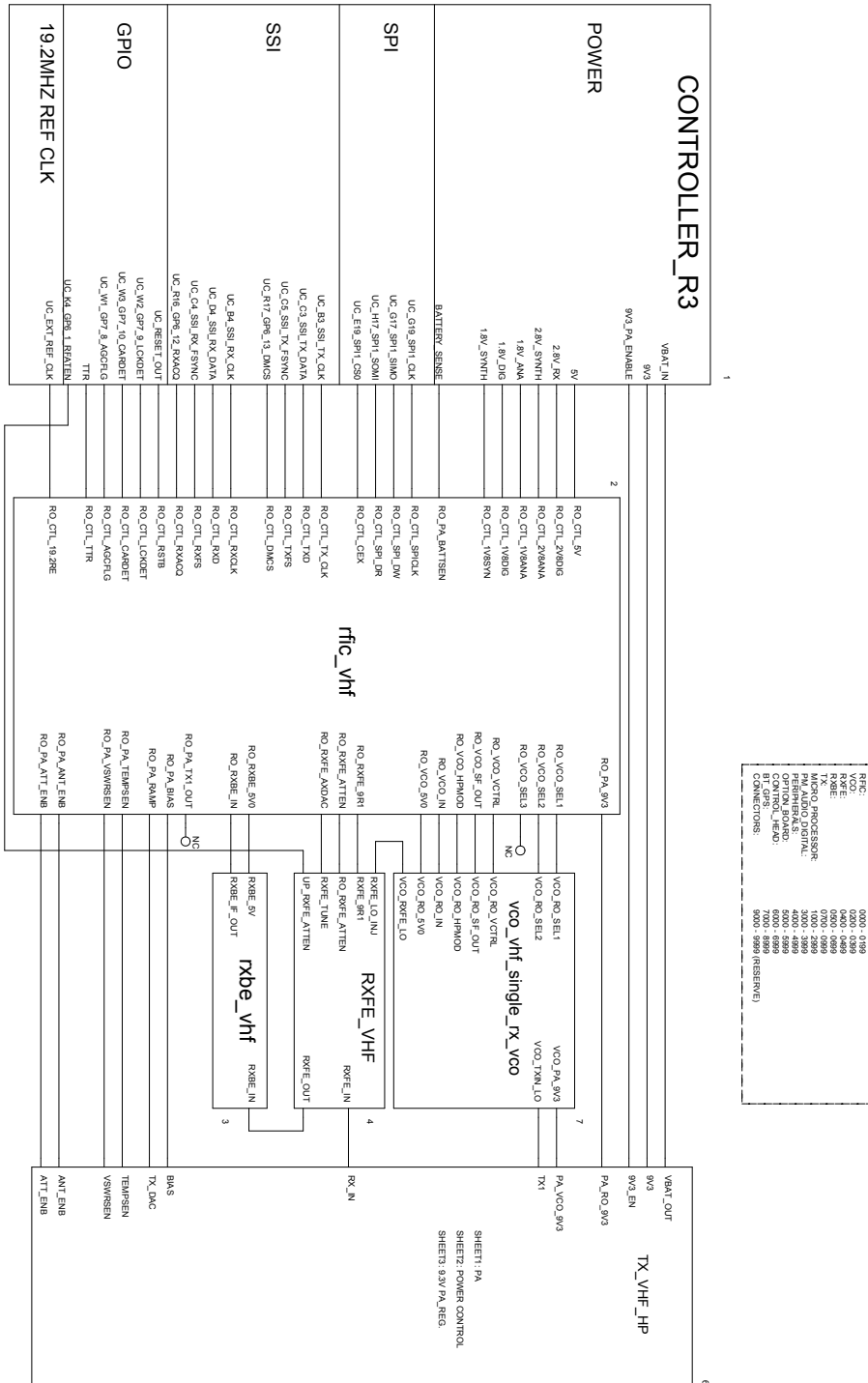

Figure 154: Overall Schematic Diagram



REF:	0000 - 0199
VCO:	0200 - 0299
RXFE:	0300 - 0399
RXBE:	0400 - 0499
TX:	0500 - 0599
TX PRO PROCESSOR:	0600 - 0699
PA AUDIO DIGITAL:	0700 - 0799
CONTROL_HEAD:	0800 - 0899
CONTROL_HEAD:	0900 - 0999
CONTROL_HEAD:	1000 - 1099
CONTROL_HEAD:	1100 - 1199
CONTROL_HEAD:	1200 - 1299
CONTROL_HEAD:	1300 - 1399
CONTROL_HEAD:	1400 - 1499
CONTROL_HEAD:	1500 - 1599
CONTROL_HEAD:	1600 - 1699
CONTROL_HEAD:	1700 - 1799
CONTROL_HEAD:	1800 - 1899
CONTROL_HEAD:	1900 - 1999
CONTROL_HEAD:	2000 - 2099
CONTROL_HEAD:	2100 - 2199
CONTROL_HEAD:	2200 - 2299
CONTROL_HEAD:	2300 - 2399
CONTROL_HEAD:	2400 - 2499
CONTROL_HEAD:	2500 - 2599
CONTROL_HEAD:	2600 - 2699
CONTROL_HEAD:	2700 - 2799
CONTROL_HEAD:	2800 - 2899
CONTROL_HEAD:	2900 - 2999
CONTROL_HEAD:	3000 - 3099
CONTROL_HEAD:	3100 - 3199
CONTROL_HEAD:	3200 - 3299
CONTROL_HEAD:	3300 - 3399
CONTROL_HEAD:	3400 - 3499
CONTROL_HEAD:	3500 - 3599
CONTROL_HEAD:	3600 - 3699
CONTROL_HEAD:	3700 - 3799
CONTROL_HEAD:	3800 - 3899
CONTROL_HEAD:	3900 - 3999
CONTROL_HEAD:	4000 - 4099
CONTROL_HEAD:	4100 - 4199
CONTROL_HEAD:	4200 - 4299
CONTROL_HEAD:	4300 - 4399
CONTROL_HEAD:	4400 - 4499
CONTROL_HEAD:	4500 - 4599
CONTROL_HEAD:	4600 - 4699
CONTROL_HEAD:	4700 - 4799
CONTROL_HEAD:	4800 - 4899
CONTROL_HEAD:	4900 - 4999
CONTROL_HEAD:	5000 - 5099
CONTROL_HEAD:	5100 - 5199
CONTROL_HEAD:	5200 - 5299
CONTROL_HEAD:	5300 - 5399
CONTROL_HEAD:	5400 - 5499
CONTROL_HEAD:	5500 - 5599
CONTROL_HEAD:	5600 - 5699
CONTROL_HEAD:	5700 - 5799
CONTROL_HEAD:	5800 - 5899
CONTROL_HEAD:	5900 - 5999
CONTROL_HEAD:	6000 - 6099
CONTROL_HEAD:	6100 - 6199
CONTROL_HEAD:	6200 - 6299
CONTROL_HEAD:	6300 - 6399
CONTROL_HEAD:	6400 - 6499
CONTROL_HEAD:	6500 - 6599
CONTROL_HEAD:	6600 - 6699
CONTROL_HEAD:	6700 - 6799
CONTROL_HEAD:	6800 - 6899
CONTROL_HEAD:	6900 - 6999
CONTROL_HEAD:	7000 - 7099
CONTROL_HEAD:	7100 - 7199
CONTROL_HEAD:	7200 - 7299
CONTROL_HEAD:	7300 - 7399
CONTROL_HEAD:	7400 - 7499
CONTROL_HEAD:	7500 - 7599
CONTROL_HEAD:	7600 - 7699
CONTROL_HEAD:	7700 - 7799
CONTROL_HEAD:	7800 - 7899
CONTROL_HEAD:	7900 - 7999
CONTROL_HEAD:	8000 - 8099
CONTROL_HEAD:	8100 - 8199
CONTROL_HEAD:	8200 - 8299
CONTROL_HEAD:	8300 - 8399
CONTROL_HEAD:	8400 - 8499
CONTROL_HEAD:	8500 - 8599
CONTROL_HEAD:	8600 - 8699
CONTROL_HEAD:	8700 - 8799
CONTROL_HEAD:	8800 - 8899
CONTROL_HEAD:	8900 - 8999
CONTROL_HEAD:	9000 - 9099
CONTROL_HEAD:	9100 - 9199
CONTROL_HEAD:	9200 - 9299
CONTROL_HEAD:	9300 - 9399
CONTROL_HEAD:	9400 - 9499
CONTROL_HEAD:	9500 - 9599
CONTROL_HEAD:	9600 - 9699
CONTROL_HEAD:	9700 - 9799
CONTROL_HEAD:	9800 - 9899
CONTROL_HEAD:	9900 - 9999

Figure 155: Receiver Front-End Schematic Diagram

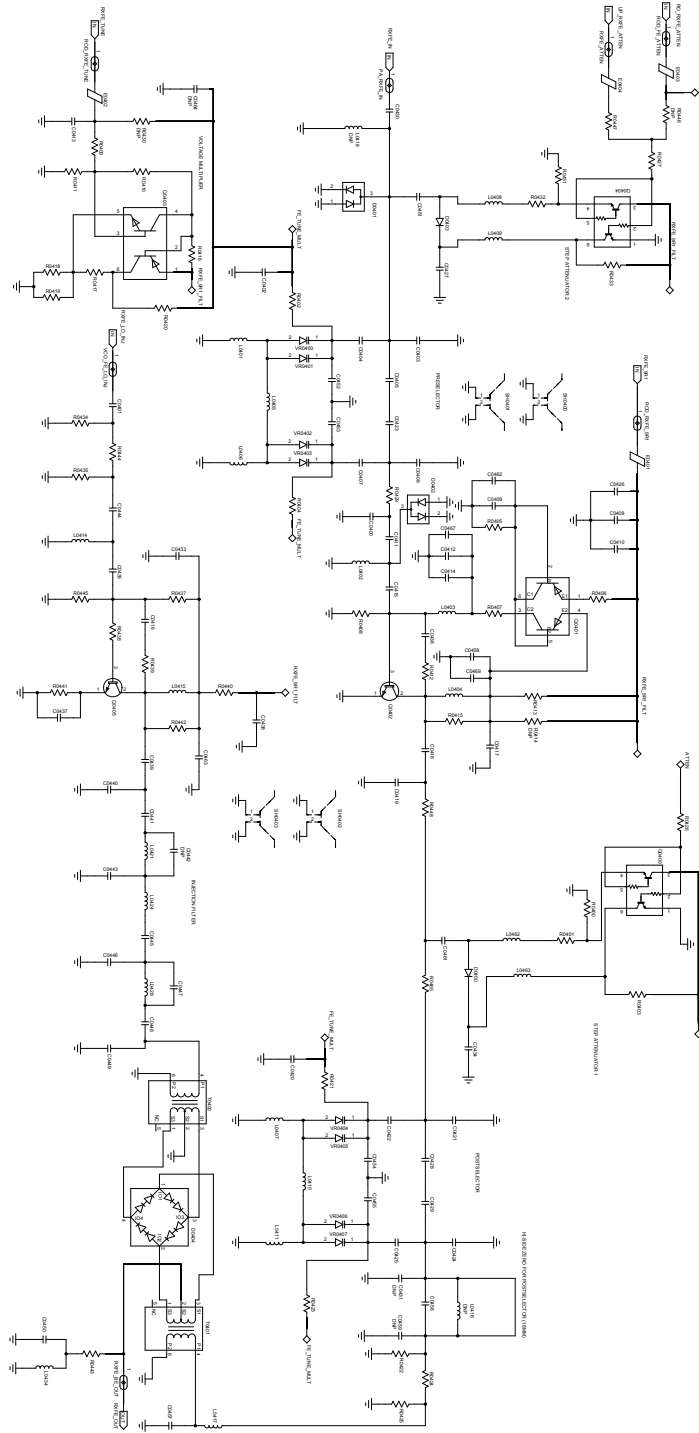

Figure 156: Receiver IF Amp Schematic Diagram

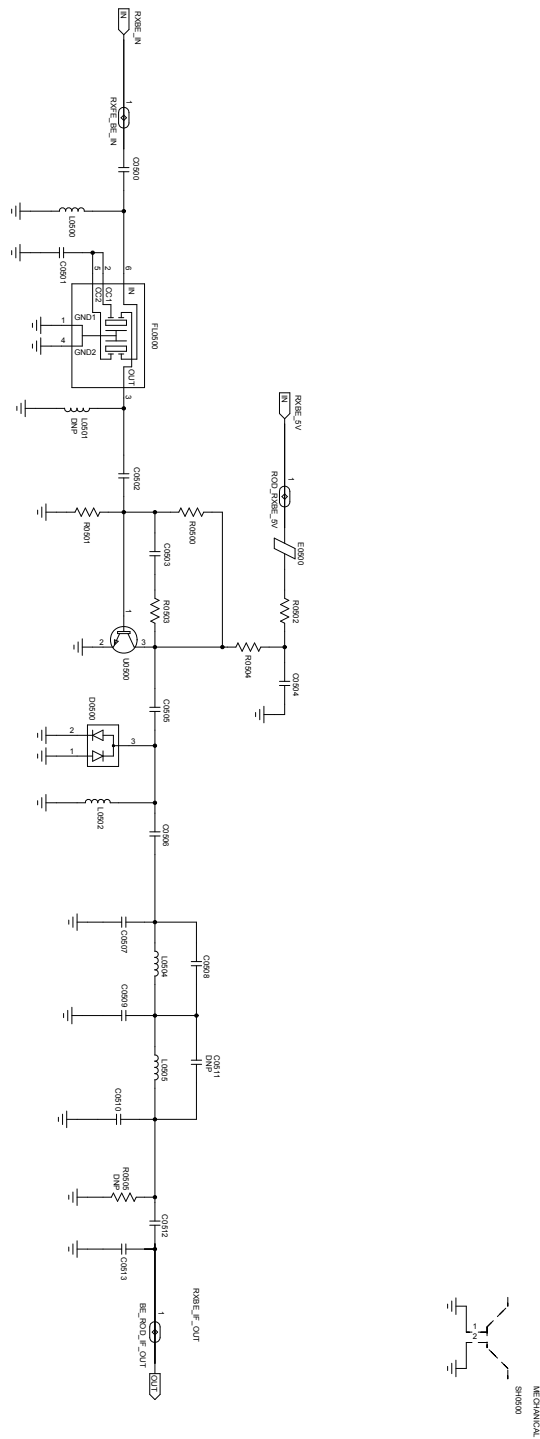

Figure 158: Power Control Schematic Diagram

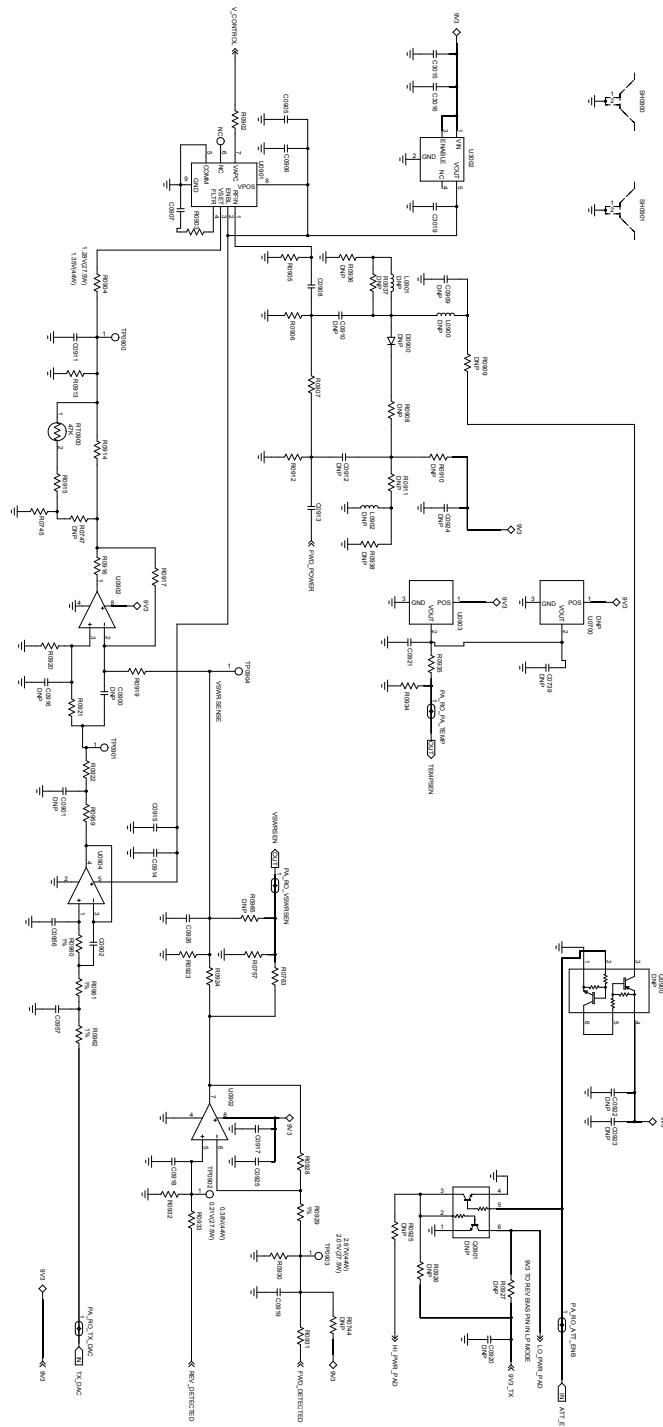

Figure 160: RFIC Schematic Diagram

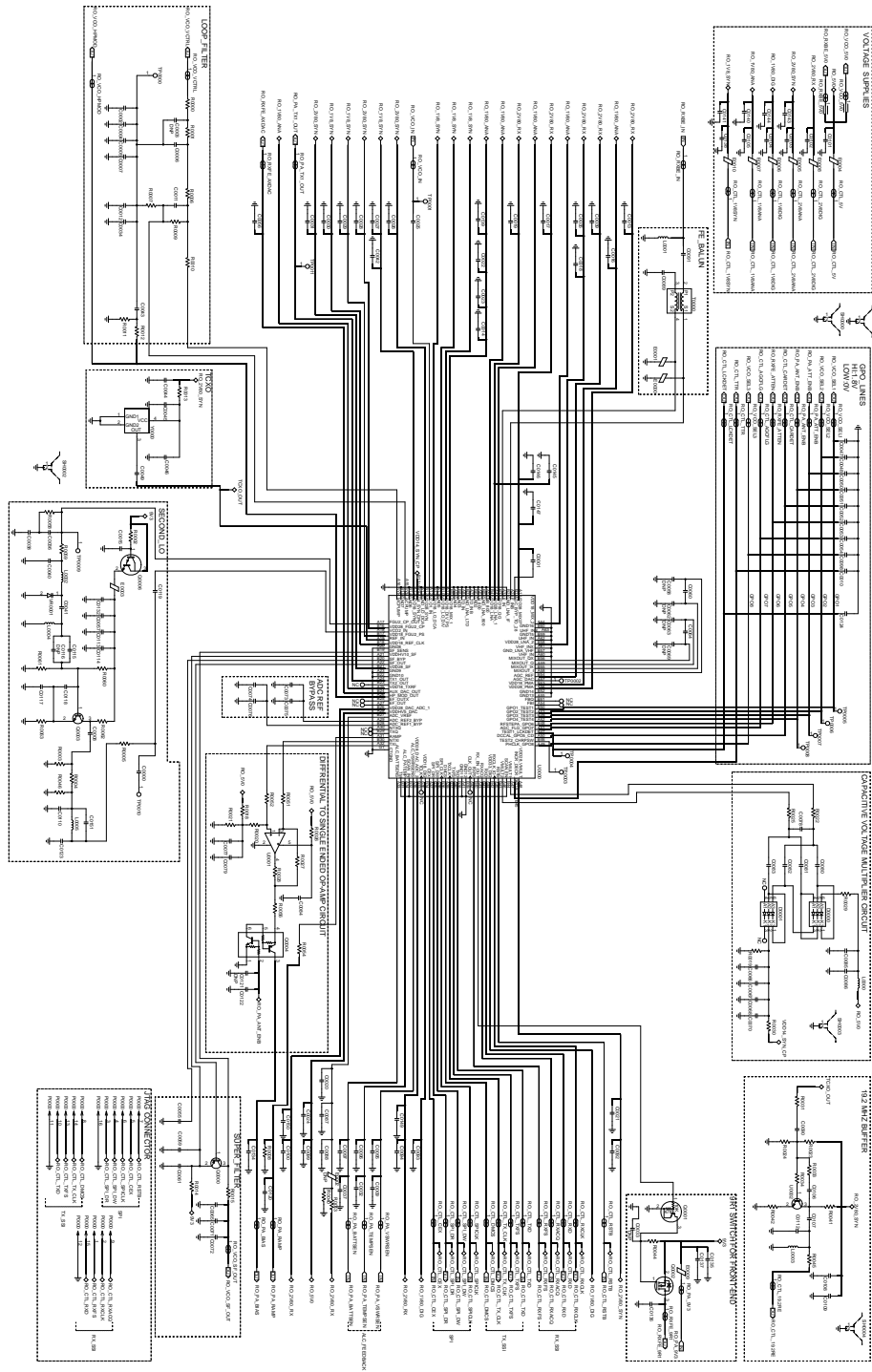

Figure 161: Receiver VCO Schematic Diagram

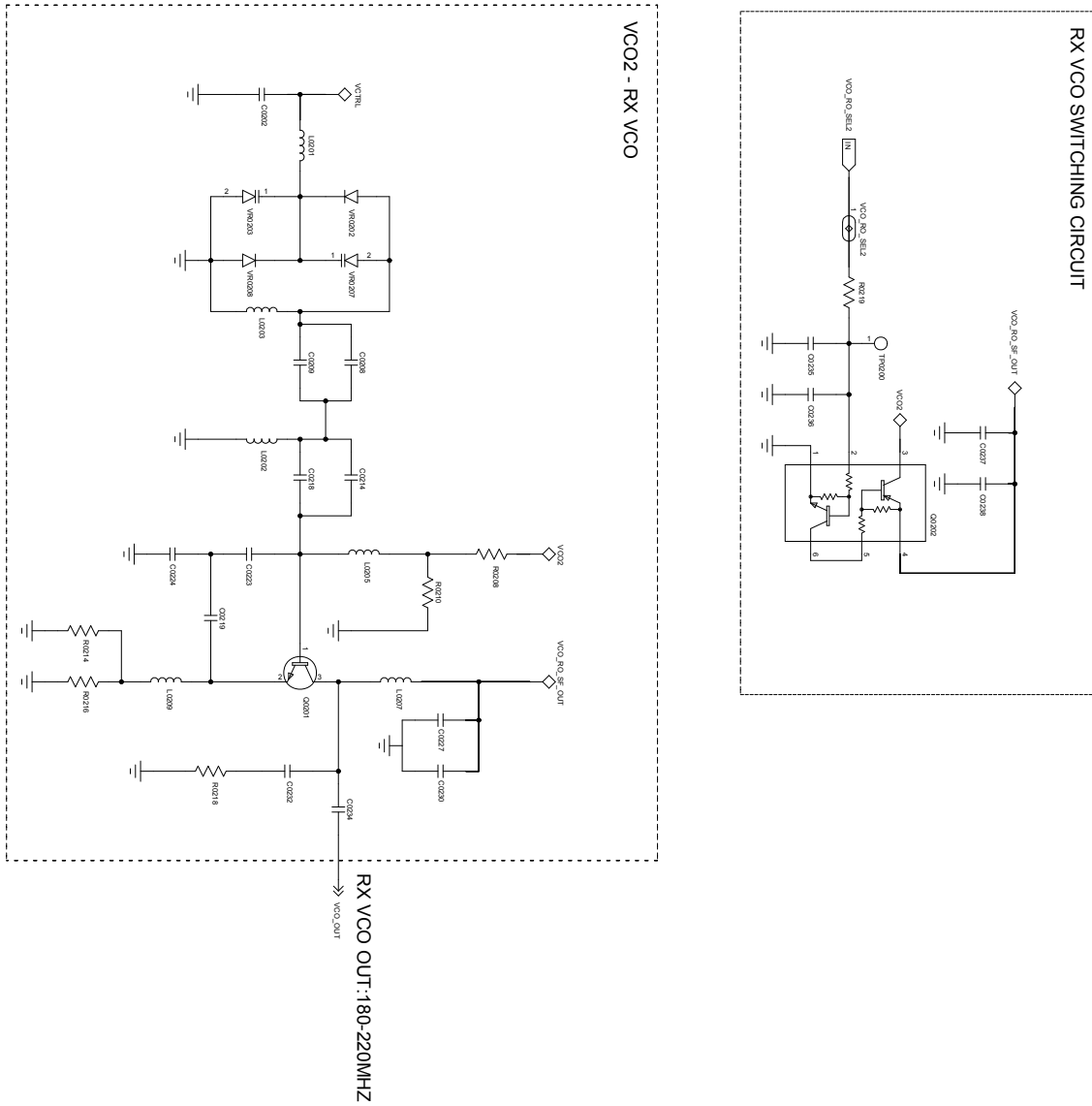
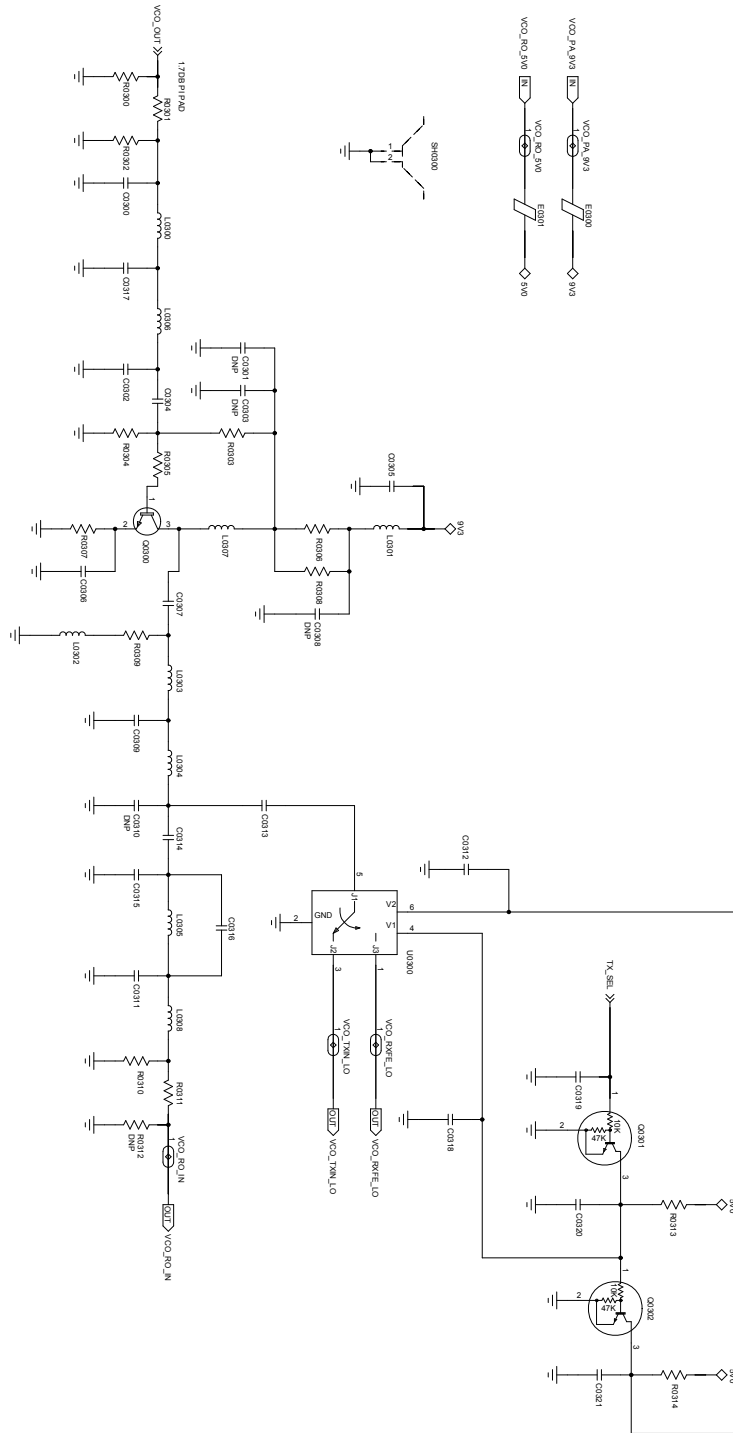

Figure 163: VCO Buffer Schematic Diagram



8.4.1.2

Parts List for 84012736001-A

Table 19: VHF Radio Part Lists

Circuit Ref.	Motorola Solutions Part No.	Circuit Ref.	Motorola Solutions Part No.
C0000M2	21667009311	L0700M6	24667008024
C0001M2	21667009170	L0701M6	24667008020
C0002M2	21012044001	L0702M6	24667008028
C0003M2	NOT PLACED	L0703M6	NOT PLACED
C0004M2	21012044001	L0704M6	NOT PLACED
C0005M2	21012044001	L0706M6	2485873L01
C0006M2	2113945C31	L0707M6	24667008031
C0007M2	21012044001	L0708M6	2479990G01
C0008M2	21667009355	L0709M6	2460591A01
C0009M2	21667009166	L0710M6	2485873L01
C0010M2	2113945A10	L0711M6	2485873L02
C0011M2	2113945C31	L0712M6	NOT PLACED
C0012M2	21012044001	L0713M6	2485873L02
C0013M2	2113945Y02	L0714M6	2460591A01
C0014M2	2113945Y02	L0715M6	2460591A01
C0015M2	2113946J03	L0716M6	2415385H02
C0016M2	2113945A10	L0717M6	24667008016
C0017M2	2113945Y02	L0718M6	24667008020
C0018M2	2113945A10	L0719M6	24667008019
C0019M2	2113945Y02	L0720M6	24667008016
C0020M2	2113945A10	L0721M6	24667008014
C0021M2	2113945Y02	L0722M6	2485873L01
C0022M2	2113945Y02	L0724M6	2485873L01
C0023M2	2113945Y02	L0727M6	2415385H07
C0024M2	21012102001	L0729M6	2414032B60
C0025M2	2113945A10	L0730M6	24667008021
C0026M2	21667009174	L0777M6	24667008020
C0027M2	2113945Y02	L0850M6	2485873L01
C0028M2	2113945Y02	L0851M6	2485873L02
C0029M2	2113945A10	L0852M6	2485873L02
C0030M2	2113945A10	L0875M6	2485873L01
C0031M2	2113945Y02	L0876M6	24667008031

Circuit Ref.	Motorola Solutions Part No.	Circuit Ref.	Motorola Solutions Part No.
C0032M2	21667009166	L0877M6	24009343030
C0033M2	NOT PLACED	L0880M6	24009343030
C0034M2	21012044001	L0885M6	2414032B49
C0035M2	2113945A10	L0899M6	2416077H16
C0036M2	21012044004	L0900M6	NOT PLACED
C0037M2	21667009166	L0901M6	NOT PLACED
C0038M2	21012044001	L0902M6	NOT PLACED
C0039M2	2113945Y02	L0950M6	0613952G67
C0040M2	2113945A10	L0951M6	NOT PLACED
C0041M2	21667009366	L0952M6	NOT PLACED
C0042M2	21667009166	L3100M1	24012091002
C0043M2	21012044001	M0700M6	2686201B02
C0044M2	2113955D45	P0000M2	NOT PLACED
C0045M2	2113945Y02	P1000M1	2887818K02
C0046M2	21667009166	P3000M6	09009344001
C0047M2	2113945A10	Q0000M2	4813973A13
C0048M2	2113945A10	Q0001M2	48009494001
C0049M2	2113945B02	Q0002M2	4813970A59
C0050M2	2113945A10	Q0003M2	48012195001
C0051M2	2113945A10	Q0004M2	4815272H01
C0052M2	2113945A10	Q0006M2	4813973A04
C0053M2	2113945A10	Q0200M7	48012195001
C0054M2	2113945A10	Q0201M7	48012195001
C0055M2	2113955D37	Q0202M7	4815272H01
C0056M2	2113945Y02	Q0206M7	4815272H01
C0057M2	2113945B02	Q0300M7	4802197J95
C0058M2	NOT PLACED	Q0301M7	48009494001
C0059M2	21667009166	Q0302M7	48009494001
C0060M2	2113945A69	Q0400M4	4815271H01
C0061M2	2113945Y02	Q0401M4	4815267H01
C0062M2	NOT PLACED	Q0402M4	48012230001
C0063M2	NOT PLACED	Q0403M4	4815270H01
C0064M2	2113945A69	Q0404M4	4815271H01
C0065M2	2113945Y02	Q0405M4	48012230001
C0066M2	2113945B02	Q0700M6	4816547H01

Circuit Ref.	Motorola Solutions Part No.	Circuit Ref.	Motorola Solutions Part No.
C0067M2	2113945Y02	Q0701M6	4816013H01
C0068M2	2113955D37	Q0702M6	48012022001
C0069M2	NOT PLACED	Q0703M6	4802246J29
C0070M2	2113955D37	Q0704M6	4816548H01
C0071M2	2113955D37	Q0875M6	4813970A62
C0072M2	21667009166	Q0876M6	48009494001
C0073M2	21667009166	Q0900M6	NOT PLACED
C0074M2	21667009166	Q0901M6	NOT PLACED
C0075M2	2113946S35	Q1000M1	4815263H01
C0076M2	2113946S35	Q1001M1	4815272H01
C0077M2	21667009166	Q1002M1	4815261H01
C0078M2	21667009372	Q1004M1	4815261H01
C0079M2	2113955D37	Q1005M1	4815261H01
C0080M2	2113945B02	Q3000M6	0105959T72
C0081M2	2113945B02	Q3001M6	0105959T72
C0082M2	2113945B02	Q3002M6	4813973B01
C0083M2	2113945B02	Q3100M1	4815272H01
C0084M2	21667009166	Q3101M1	4809939C47
C0085M2	2113945A10	Q3102M1	4809939C47
C0086M2	2113945C31	Q3103M1	48009494001
C0087M2	2113946S35	Q3105M1	4809939C47
C0088M2	2113945Y02	Q3160M1	48009494001
C0089M2	2113945Y02	Q3161M1	4815272H01
C0090M2	2113945B02	Q3162M1	4813973M07
C0091M2	2113944C45	Q3163M1	48009494001
C0092M2	2113945A10	Q3200M1	4815270H01
C0093M2	2113945Y02	Q3201M1	4815272H01
C0094M2	2113945Y02	Q3202M1	4815270H01
C0095M2	2113945A13	Q3203M1	4815270H01
C0096M2	2113945B02	Q3204M1	4815270H01
C0097M2	2113945B02	Q3205M1	4815270H01
C0098M2	2113945A10	Q3206M1	4815270H01
C0099M2	2113945Y02	Q3207M1	4815270H01
C0100M2	2113945Y02	Q3208M1	4815263H01
C0101M2	2113945A10	Q4000M1	4809939C47

Circuit Ref.	Motorola Solutions Part No.	Circuit Ref.	Motorola Solutions Part No.
C0102M2	2113945A10	Q4001M1	4809939C47
C0103M2	2113945A10	Q4002M1	4809939C47
C0104M2	2113945A10	Q4100M1	4816023H01
C0105M2	2113945A10	Q4101M1	4815261H01
C0106M2	2113945B02	Q4102M1	4815263H01
C0107M2	2113945B02	Q4103M1	48012271001
C0108M2	2113945A10	Q4105M1	48012271001
C0109M2	2113945Y02	Q4106M1	48012271001
C0110M2	21667009381	Q4109M1	48012271001
C0112M2	21667009166	Q4112M1	48012271001
C0113M2	2113945A10	Q4120M1	4809939C47
C0114M2	2113945Y02	R0000M2	0613952R66
C0115M2	21667009372	R0001M2	0613952R66
C0116M2	NOT PLACED	R0002M2	0613952Q96
C0117M2	21667009388	R0003M2	0613952Q57
C0118M2	21667009378	R0004M2	0613952Q34
C0119M2	2113945A10	R0005M2	0613952R66
C0120M2	2113945A10	R0006M2	0613952Q25
C0121M2	NOT PLACED	R0007M2	0613952Q51
C0122M2	21667009166	R0008M2	0613952R01
C0123M2	21667009381	R0009M2	0613952Q58
C0124M2	21667009166	R0010M2	0613952R66
C0132M2	2113946J03	R0011M2	0613952Q35
C0134M2	2113945A10	R0012M2	0613952Q81
C0135M2	21667009166	R0013M2	0613952Q35
C0136M2	21667009166	R0014M2	0613952R66
C0137M2	2113945Y02	R0015M2	0613952R66
C0138M2	2113945A10	R0018M2	0613952Q80
C0139M2	2113945A10	R0019M2	0613952R01
C0140M2	2113945Y02	R0020M2	0613952R12
C0141M2	2113945Y02	R0021M2	0613952Q80
C0143M2	2113945Y02	R0022M2	0613952R66
C0144M2	2113945Y02	R0023M2	0613952Q83
C0145M2	21667009166	R0024M2	0613952Q80
C0146M2	2113945A10	R0025M2	0613952R66

Circuit Ref.	Motorola Solutions Part No.	Circuit Ref.	Motorola Solutions Part No.
C0147M2	2113945A10	R0026M2	0613952R66
C0149M2	2113945A10	R0027M2	0613952R12
C0150M2	2113945A10	R0028M2	0613952R66
C0151M2	21667009372	R0029M2	0613952Q25
C0200M7	2113945A10	R0030M2	0613952R66
C0201M7	NOT PLACED	R0031M2	0613952R66
C0202M7	2113945A10	R0033M2	0613952R01
C0203M7	NOT PLACED	R0034M2	0613952Q57
C0204M7	NOT PLACED	R0040M2	0613952Q70
C0206M7	21667009355	R0041M2	0613952Q58
C0207M7	21667009355	R0042M2	0613952Q42
C0208M7	21667009366	R0043M2	0613952Q73
C0209M7	21667009366	R0044M2	0613952R25
C0210M7	21667009274	R0045M2	0613952R66
C0211M7	NOT PLACED	R0046M2	0613952Q57
C0212M7	NOT PLACED	R0051M2	0613952R01
C0214M7	21667009315	R0052M2	0613952R01
C0217M7	21667009204	R0054M2	0613952M25
C0218M7	21667009315	R0056M2	0613952R66
C0219M7	2113945A04	R0058M2	0613952Q81
C0221M7	21667009371	R0059M2	0613952R66
C0222M7	21667009374	R0060M2	0613952Q86
C0223M7	21667009378	R0061M2	0613952Q85
C0224M7	21667009377	R0062M2	0613952Q61
C0225M7	2113945Y02	R0063M2	0613952Q64
C0227M7	2113945Y02	R0200M7	0613952R66
C0229M7	2113945A10	R0201M7	0613952R66
C0230M7	2113945A10	R0202M7	0613952R27
C0231M7	2113945A10	R0205M7	0613952R07
C0232M7	2113945A10	R0206M7	0613952R05
C0233M7	21667009284	R0207M7	0613952Q86
C0234M7	21667009284	R0208M7	0613952Q78
C0235M7	2113945A10	R0209M7	0613952Q85
C0236M7	2113945Y02	R0210M7	0613952Q73
C0237M7	2113945A10	R0211M7	0613952Q18

Circuit Ref.	Motorola Solutions Part No.	Circuit Ref.	Motorola Solutions Part No.
C0238M7	2113945Y02	R0213M7	0613952Q67
C0269M7	2113945A10	R0214M7	0613952Q67
C0270M7	2113945Y02	R0215M7	0613952Q67
C0271M7	2113945A10	R0216M7	0613952Q67
C0272M7	2113945Y02	R0217M7	0613952Q49
C0300M7	21667009378	R0218M7	0613952Q49
C0301M7	NOT PLACED	R0219M7	0613952R66
C0302M7	21667009300	R0233M7	0613952R66
C0303M7	NOT PLACED	R0300M7	0613952Q66
C0304M7	21667009392	R0301M7	0613952Q25
C0305M7	2113945Y02	R0302M7	0613952Q66
C0306M7	2113945A09	R0303M7	0613952Q94
C0307M7	2113945A02	R0304M7	0613952Q89
C0308M7	NOT PLACED	R0305M7	0613952Q32
C0309M7	21667009370	R0306M7	0613952Q49
C0310M7	NOT PLACED	R0307M7	0613952H46
C0311M7	21667009368	R0308M7	0613952Q49
C0312M7	2113945A10	R0309M7	0613952Q42
C0313M7	2113945A10	R0310M7	0613952Q39
C0314M7	21667009366	R0311M7	0613952R66
C0315M7	21667009315	R0312M7	NOT PLACED
C0316M7	21667009371	R0313M7	0613952Q73
C0317M7	21667009377	R0314M7	0613952Q73
C0318M7	2113945A10	R0400M4	0613952R01
C0319M7	2113945A10	R0401M4	0613952H81
C0320M7	2113945A10	R0402M4	0613952R25
C0321M7	2113945A10	R0403M4	0613952R01
C0400M4	21667009279	R0404M4	0613952R25
C0401M4	2113945A10	R0405M4	0613952R05
C0402M4	2113945A10	R0406M4	0613952Q91
C0403M4	21667009291	R0407M4	0613952Q91
C0404M4	21667009385	R0408M4	0613952Q73
C0405M4	21667009282	R0409M4	0613952R66
C0406M4	21667009291	R0410M4	0613952R01
C0407M4	21667009385	R0411M4	0613952R01

Circuit Ref.	Motorola Solutions Part No.	Circuit Ref.	Motorola Solutions Part No.
C0408M4	2113945C31	R0412M4	0613952Q75
C0409M4	2113945C31	R0413M4	0613958H44
C0410M4	2113945A10	R0414M4	NOT PLACED
C0411M4	2113945A10	R0415M4	0613952Q75
C0412M4	2113946F05	R0416M4	0613952Q69
C0413M4	21667009166	R0417M4	0613952Q75
C0414M4	2113945A10	R0418M4	0613952Q69
C0415M4	21667009388	R0419M4	0613952Q69
C0416M4	2113945C31	R0420M4	0613952R25
C0417M4	2113945A10	R0421M4	0613952R25
C0418M4	21667009383	R0422M4	0613952Q53
C0419M4	21667009315	R0423M4	0613952R25
C0420M4	2113945A10	R0424M4	0613952Q39
C0421M4	21667009291	R0425M4	0613952Q53
C0422M4	21667009385	R0426M4	0613952Q87
C0423M4	21667009282	R0427M4	0613952Q87
C0424M4	21667009291	R0429M4	0613952R66
C0425M4	21667009385	R0430M4	NOT PLACED
C0426M4	2113946F05	R0431M4	0613952R01
C0427M4	2113945A05	R0432M4	0613952H75
C0428M4	21667009282	R0433M4	0613952R01
C0429M4	21667009282	R0434M4	0613952L46
C0430M4	2113945A10	R0435M4	0613952L46
C0431M4	NOT PLACED	R0437M4	0613952Q80
C0433M4	2113945A10	R0438M4	0613952Q25
C0434M4	2113945A05	R0439M4	0613952Q69
C0435M4	21667009388	R0440M4	0613958H25
C0436M4	2113945C31	R0441M4	0613958H44
C0437M4	2113945A10	R0442M4	0613952Q83
C0438M4	2113945A10	R0443M4	0613952Q46
C0439M4	21667009365	R0444M4	0613952K25
C0440M4	21667009364	R0445M4	0613952Q75
C0441M4	21667009373	R0446M4	NOT PLACED
C0442M4	NOT PLACED	R0447M4	0613952R66
C0443M4	21667009373	R0448M4	0613952Q25

Circuit Ref.	Motorola Solutions Part No.	Circuit Ref.	Motorola Solutions Part No.
C0444M4	21667009388	R0465M4	0613952R66
C0445M4	21667009375	R0500M3	0613952R08
C0446M4	21667009372	R0501M3	0613952R03
C0447M4	21667009303	R0502M3	0613952Q81
C0448M4	21667009373	R0503M3	0613952Q87
C0449M4	21667009364	R0504M3	0613952Q61
C0450M4	21667009386	R0505M3	NOT PLACED
C0451M4	2113945A10	R0700M6	0613952J01
C0452M4	21667009378	R0701M6	0613952G67
C0453M4	21667009378	R0702M6	0613952H49
C0454M4	21667009378	R0703M6	0613952J01
C0455M4	21667009378	R0704M6	0613952J01
C0456M4	2113945A10	R0705M6	0613952H47
C0457M4	21667009372	R0706M6	0613952H48
C0458M4	2113946F05	R0707M6	0613952H47
C0459M4	NOT PLACED	R0708M6	NOT PLACED
C0461M4	2113945A10	R0709M6	NOT PLACED
C0462M4	2113945A10	R0710M6	NOT PLACED
C0463M4	2113945A10	R0711M6	0613958S49
C0464M4	NOT PLACED	R0712M6	0613958S49
C0467M4	2113956B21	R0713M6	NOT PLACED
C0469M4	2113956B21	R0714M6	0613952H35
C0500M3	21667009371	R0715M6	0613952H35
C0501M3	21667009355	R0716M6	0613952H35
C0502M3	2113945Y02	R0717M6	0613952H35
C0503M3	2113945Y02	R0718M6	0613952H96
C0504M3	2113945Y02	R0719M6	0613952H89
C0505M3	21667009370	R0720M6	0613952J01
C0506M3	21667009371	R0721M6	0613952G67
C0507M3	21667009307	R0722M6	0613952H25
C0508M3	21667009332	R0723M6	0613952G67
C0509M3	21667009380	R0724M6	0613959Q53
C0510M3	21667009307	R0725M6	0613958S29
C0511M3	NOT PLACED	R0726M6	0613958S29
C0512M3	21667009390	R0727M6	0613958S29

Circuit Ref.	Motorola Solutions Part No.	Circuit Ref.	Motorola Solutions Part No.
C0513M3	21667009378	R0728M6	0613958S29
C0700M6	2113944C85	R0729M6	0613958S29
C0701M6	21667009174	R0730M6	0613958S29
C0702M6	2113944C83	R0731M6	0613958S29
C0703M6	2113944C51	R0732M6	0613958S29
C0704M6	NOT PLACED	R0733M6	0613958S29
C0705M6	NOT PLACED	R0734M6	0613958S29
C0706M6	NOT PLACED	R0735M6	0613958S29
C0707M6	2113945C31	R0736M6	0613959Q25
C0708M6	2113944C82	R0737M6	0613952F01
C0709M6	2113945C04	R0738M6	0613958S29
C0710M6	21667009174	R0739M6	0613952H73
C0712M6	2113945L49	R0740M6	0613952H73
C0713M6	21667009174	R0741M6	0613952E66
C0714M6	NOT PLACED	R0742M6	0613952H73
C0715M6	NOT PLACED	R0743M6	0613952E66
C0716M6	2113944C51	R0744M6	NOT PLACED
C0718M6	NOT PLACED	R0745M6	0613952R66
C0719M6	NOT PLACED	R0746M6	0613952F01
C0720M6	2113944C51	R0747M6	NOT PLACED
C0721M6	2113945L37	R0748M6	0613958J49
C0723M6	2171741Y01	R0749M6	0613958J49
C0724M6	2113944C46	R0750M6	0613958J49
C0725M6	2113944C51	R0751M6	0613958J49
C0726M6	2113944C51	R0752M6	0613958J49
C0727M6	NOT PLACED	R0753M6	0613958J49
C0728M6	2111078B39	R0754M6	0613958J49
C0729M6	2113944C51	R0755M6	0613959H12
C0730M6	2113945L49	R0756M6	0613959H12
C0731M6	21667009174	R0757M6	0613952N43
C0732M6	2113945A09	R0758M6	0613958J49
C0733M6	2113944C45	R0759M6	0613959H12
C0734M6	2113944C51	R0760M6	0613958J49
C0735M6	2113944C33	R0761M6	0613958J49
C0736M6	2111078B18	R0762M6	0613958J49

Circuit Ref.	Motorola Solutions Part No.	Circuit Ref.	Motorola Solutions Part No.
C0737M6	2113944C04	R0763M6	0613952P01
C0738M6	2113944C46	R0876M6	0613958S73
C0739M6	NOT PLACED	R0877M6	0613959Y37
C0740M6	2113945C25	R0878M6	0613959Y37
C0741M6	21667007049	R0879M6	0613952J25
C0742M6	2113944C30	R0882M6	0613952G67
C0743M6	2113944F67	R0883M6	0613952G67
C0744M6	2113944F02	R0902M6	0613952R66
C0745M6	21009337414	R0903M6	0613952N01
C0746M6	NOT PLACED	R0904M6	0613952R66
C0747M6	NOT PLACED	R0905M6	0613952H42
C0748M6	2113945C31	R0906M6	0613958H46
C0749M6	NOT PLACED	R0907M6	0613958H55
C0750M6	NOT PLACED	R0908M6	NOT PLACED
C0751M6	NOT PLACED	R0909M6	NOT PLACED
C0752M6	2111078B59	R0910M6	NOT PLACED
C0753M6	2113944C51	R0911M6	NOT PLACED
C0754M6	2113944C45	R0912M6	0613958H46
C0755M6	2113944C36	R0913M6	0613952M51
C0756M6	2111078B39	R0914M6	0613952M71
C0757M6	2111078B39	R0915M6	0613952Z76
C0758M6	2111078B42	R0916M6	0613952R66
C0759M6	2111078B42	R0917M6	0613952P01
C0760M6	2113944C79	R0919M6	0613952P01
C0761M6	2113944C45	R0920M6	0613952N01
C0762M6	2111078B34	R0921M6	0613952N01
C0763M6	NOT PLACED	R0922M6	0613952R66
C0764M6	2113944C51	R0923M6	0613952M43
C0766M6	2111078B34	R0924M6	0613952N01
C0768M6	2111078B38	R0925M6	NOT PLACED
C0769M6	NOT PLACED	R0926M6	NOT PLACED
C0770M6	2111078B18	R0927M6	NOT PLACED
C0771M6	NOT PLACED	R0928M6	0613952P30
C0772M6	NOT PLACED	R0929M6	0613952N81
C0773M6	2111078B39	R0930M6	0613952N51

Circuit Ref.	Motorola Solutions Part No.	Circuit Ref.	Motorola Solutions Part No.
C0774M6	2111078B36	R0931M6	0613952Z26
C0775M6	2113944C06	R0932M6	0613952Z60
C0776M6	2113944C31	R0933M6	0613952Z50
C0777M6	NOT PLACED	R0934M6	0613952J17
C0778M6	21667011432	R0935M6	0613952H91
C0779M6	2113944C31	R0936M6	NOT PLACED
C0780M6	NOT PLACED	R0937M6	NOT PLACED
C0781M6	NOT PLACED	R0938M6	NOT PLACED
C0782M6	NOT PLACED	R0950M6	0613952G67
C0783M6	NOT PLACED	R0951M6	0613958H55
C0784M6	2113944C85	R0952M6	0613958H53
C0793M6	21667007048	R0953M6	0613952G67
C0794M6	2113944F07	R0954M6	0613952H39
C0796M6	21667007035	R0955M6	0613952H39
C0797M6	21667007035	R0956M6	0613952G67
C0798M6	21667007035	R0957M6	0613958H55
C0799M6	21667007035	R0958M6	0613958H53
C0801M6	NOT PLACED	R0959M6	0613952R66
C0802M6	NOT PLACED	R0960M6	0613952N58
C0803M6	NOT PLACED	R0961M6	0613952N58
C0804M6	NOT PLACED	R0962M6	0613952N58
C0812M6	NOT PLACED	R0965M6	NOT PLACED
C0814M6	NOT PLACED	R1000M1	0613952R66
C0818M6	NOT PLACED	R1001M1	0613952M66
C0824M6	2111078B11	R1002M1	0613952R66
C0850M6	2111078B25	R1003M1	0613952R66
C0851M6	2111078B44	R1004M1	0613952R66
C0852M6	2111078B11	R1005M1	0613952M66
C0853M6	2111078B34	R1007M1	0613952R66
C0854M6	2111078B34	R1008M1	0613952R66
C0855M6	2111078B11	R1009M1	0613952R66
C0856M6	2111078B49	R1010M1	NOT PLACED
C0875M6	2113944C47	R1011M1	NOT PLACED
C0876M6	2113944C32	R1012M1	0613952R66
C0877M6	2113944C06	R1013M1	0613952M66

Circuit Ref.	Motorola Solutions Part No.	Circuit Ref.	Motorola Solutions Part No.
C0879M6	2113944C06	R1014M1	NOT PLACED
C0880M6	2113944C35	R1016M1	NOT PLACED
C0881M6	2111078B27	R1018M1	NOT PLACED
C0882M6	2111078B57	R1019M1	0613952R66
C0883M6	NOT PLACED	R1020M1	0613952M66
C0884M6	2113944F05	R1021M1	0613952Q73
C0885M6	2113944C51	R1022M1	NOT PLACED
C0899M6	2111078B04	R1023M1	0613952R66
C0900M6	NOT PLACED	R1024M1	NOT PLACED
C0901M6	NOT PLACED	R1025M1	0613952Q73
C0902M6	2113944C51	R1026M1	0613952R66
C0905M6	2113945C31	R1027M1	NOT PLACED
C0906M6	2113945A10	R1028M1	0613952R66
C0907M6	2113945L41	R1029M1	0613952R66
C0908M6	21667009174	R1030M1	NOT PLACED
C0909M6	NOT PLACED	R1031M1	0613952R66
C0910M6	NOT PLACED	R1033M1	0613952Q73
C0911M6	2113944C02	R1034M1	0613952R17
C0912M6	NOT PLACED	R1035M1	NOT PLACED
C0913M6	21667009174	R1036M1	0613952M66
C0914M6	21667009174	R1037M1	0613952M66
C0915M6	2113946B04	R1038M1	0613952R66
C0916M6	NOT PLACED	R1039M1	0613952R66
C0917M6	21667009174	R1040M1	0613952M66
C0918M6	21667009174	R1041M1	0613952R66
C0919M6	21667009174	R1042M1	0613952M66
C0920M6	NOT PLACED	R1043M1	0613952R66
C0921M6	2113944C51	R1044M1	0613952M66
C0922M6	NOT PLACED	R1045M1	0613952M66
C0923M6	NOT PLACED	R1046M1	0613952M66
C0924M6	NOT PLACED	R1047M1	0613952R66
C0925M6	2113946B04	R1048M1	0613952R66
C0926M6	2113944C02	R1049M1	0613952Q73
C0950M6	2113944C51	R1050M1	0613952Q73
C0951M6	2113944C30	R1051M1	0613952K68

Circuit Ref.	Motorola Solutions Part No.	Circuit Ref.	Motorola Solutions Part No.
C0952M6	2113944C51	R1052M1	NOT PLACED
C0953M6	2113944C51	R1053M1	0613952R66
C0954M6	2113944C81	R1054M1	0613952M66
C0955M6	2113944C51	R1056M1	0613952Q73
C0956M6	2113944C01	R1057M1	0613952Q73
C0957M6	2113944C49	R1058M1	0613952M66
C1000M1	2113945Y02	R1059M1	0613952R66
C1001M1	2113945Y02	R1060M1	0613952R66
C1002M1	2113946K03	R1061M1	0613952R66
C1003M1	2113945Y02	R1062M1	NOT PLACED
C1004M1	2113945Y02	R1063M1	NOT PLACED
C1005M1	2113945Y02	R1064M1	NOT PLACED
C1006M1	2113945Y02	R1065M1	0613952R66
C1007M1	2113945Y02	R1066M1	0613952M66
C1008M1	2113946D05	R1067M1	0613952M66
C1009M1	2113945Y02	R1068M1	0613952R32
C1010M1	2113945Y02	R1069M1	NOT PLACED
C1011M1	2113945B02	R1070M1	0613952Q77
C1012M1	2113945Y02	R1071M1	0613952Q77
C1013M1	2113945Y02	R1072M1	0613952Q49
C1014M1	2113945Y02	R1073M1	0613952R01
C1015M1	2113945B02	R1074M1	0613952R66
C1016M1	21667009166	R1075M1	0613952R66
C1017M1	21667009162	R1076M1	0613952R66
C1018M1	21667009162	R1077M1	0613952R66
C1019M1	21667009162	R1078M1	0613952R66
C1020M1	21667009162	R1079M1	0613952R66
C1021M1	2113945Y02	R1080M1	0613952Q32
C1022M1	2113945Y02	R1081M1	0613952Q32
C1023M1	2113945Y02	R1082M1	0613952Q32
C1024M1	2113945Y02	R1084M1	0613952R66
C1025M1	2113945Y02	R1088M1	NOT PLACED
C1026M1	2113945Y02	R1089M1	0613952R05
C1027M1	NOT PLACED	R1090M1	0613952R05
C1028M1	2113945Y02	R1091M1	NOT PLACED

Circuit Ref.	Motorola Solutions Part No.	Circuit Ref.	Motorola Solutions Part No.
C1029M1	2113956B54	R1092M1	0613952M43
C1032M1	2113956B54	R1093M1	0613952Q73
C1035M1	2113945B02	R1094M1	0613952M66
C1036M1	2113946D05	R1095M1	0613952Q34
C1040M1	2113945Y02	R1096M1	0613952Q34
C1041M1	2113945B02	R1097M1	0613952R66
C1042M1	2113945Y02	R1098M1	0613952R66
C1043M1	2113956B54	R2000M1	0613952M66
C1044M1	2113945B02	R2002M1	0613952M66
C1045M1	2113945B02	R2003M1	0613952M30
C1047M1	2113945Y02	R3000M6	0613952H60
C1048M1	2113945B02	R3001M6	0615871H01
C2000M1	2113945Y02	R3002M6	0615871H01
C2001M1	2113945Y02	R3003M6	0615871H01
C2002M1	2113945B02	R3004M6	0615871H01
C2003M1	21667009162	R3005M6	0613952H25
C2004M1	2113956B54	R3006M6	0613952H25
C2005M1	2113946D05	R3007M6	0613952M30
C2006M1	2113945Y02	R3008M6	0613952G67
C2007M1	2113945Y02	R3009M6	0613952M43
C2008M1	2113945B02	R3010M6	0613952G67
C2009M1	21667009162	R3011M6	0613959Q60
C2010M1	2113945Y02	R3012M6	0613959Q60
C2011M1	2113945Y02	R3013M6	0613952R01
C2012M1	2113945Y02	R3014M6	0613952R01
C2013M1	2113945Y02	R3015M6	0615871H01
C2014M1	2113945B02	R3018M6	0613952H73
C2015M1	21667009162	R3019M6	0613952H60
C2016M1	2113956B54	R3020M6	0613952G67
C2020M1	2113956B54	R3021M6	0613952R25
C2021M1	2113956D59	R3101M1	0613952Z66
C2022M1	2113956D59	R3102M1	0613952M66
C3000M6	2113944C38	R3103M1	0613952N62
C3001M6	2113944C06	R3104M1	0613952M30
C3002M6	2113944C06	R3105M1	0613952R01

Circuit Ref.	Motorola Solutions Part No.	Circuit Ref.	Motorola Solutions Part No.
C3003M6	2113945C31	R3106M1	0613952M09
C3004M6	2113945C02	R3107M1	0613952M85
C3005M6	2113945C02	R3108M1	0613952R17
C3008M6	2113944C51	R3109M1	0613952R17
C3009M6	2113945C31	R3110M1	0613952N55
C3010M6	2113944C46	R3111M1	0613952R32
C3011M6	2113945G53	R3112M1	0613952P12
C3012M6	2113946J04	R3113M1	0613952R17
C3013M6	2113945C31	R3114M1	0613952N01
C3014M6	21009337414	R3115M1	0613952Z63
C3015M6	2113946G01	R3116M1	0613952E83
C3016M6	2113945C31	R3117M1	0613952Q73
C3019M6	2113946S35	R3118M1	0613952R10
C3020M6	2113945C26	R3119M1	0613952Q73
C3021M6	2113944C06	R3120M1	0613952R66
C3022M6	2113945A10	R3121M1	0613952R66
C3029M6	NOT PLACED	R3122M1	0613952M43
C3038M6	21667009169	R3123M1	0613952M54
C3041M6	21667009169	R3124M1	0613952R66
C3042M6	21667009169	R3125M1	0613952R66
C3044M6	21667009169	R3126M1	0613952R66
C3046M6	21667009174	R3127M1	0613959Y09
C3047M6	21667009174	R3128M1	0613952M10
C3048M6	21667009174	R3129M1	0613952M58
C3049M6	21667009174	R3130M1	0613952R25
C3102M1	21009337414	R3131M1	0613952R01
C3103M1	21667009166	R3132M1	0613952R01
C3104M1	2113946F08	R3133M1	0613952R29
C3105M1	2113946J04	R3134M1	NOT PLACED
C3106M1	2113945C31	R3135M1	0613952R66
C3107M1	2113944C38	R3136M1	0613952R17
C3109M1	21667009166	R3137M1	0613952R17
C3110M1	2113944C06	R3138M1	0613952R17
C3111M1	2113946J04	R3139M1	0613952R66
C3112M1	2113945Y02	R3140M1	0613952Q91

Circuit Ref.	Motorola Solutions Part No.	Circuit Ref.	Motorola Solutions Part No.
C3113M1	2113946S35	R3141M1	0613959Y13
C3115M1	2113944C06	R3142M1	NOT PLACED
C3116M1	2113955D13	R3143M1	0613952Q91
C3117M1	2113955D13	R3144M1	0613952R66
C3118M1	2113945Y02	R3145M1	0613959Y09
C3119M1	2113945Y02	R3146M1	0613952M85
C3120M1	2113956E60	R3147M1	0613952M43
C3121M1	2113956D58	R3148M1	0613952R66
C3122M1	2113956A51	R3149M1	0613952R01
C3123M1	2113956A51	R3150M1	0613952N62
C3124M1	2113946D07	R3151M1	0613952R25
C3125M1	2113946D05	R3153M1	0613952R66
C3126M1	2113944C06	R3154M1	0613952Q89
C3127M1	2113946S35	R3155M1	0613952Q89
C3128M1	2113946D05	R3156M1	0613952R17
C3129M1	2113945Y02	R3157M1	0613952R01
C3130M1	2113946D05	R3158M1	0613952R66
C3131M1	2113946A02	R3159M1	0613952R01
C3132M1	2113946D05	R3160M1	0613952Q89
C3133M1	2113946D05	R3161M1	0613952Q73
C3134M1	2113946S35	R3162M1	0613952Q85
C3135M1	2113956A51	R3163M1	0613952R01
C3136M1	21012095001	R3164M1	0613952Q75
C3137M1	2113946D05	R3165M1	0613952R01
C3139M1	2113956A51	R3166M1	0613952R17
C3140M1	21012095001	R3167M1	0613952R01
C3141M1	2113945Y02	R3168M1	0613952Q73
C3142M1	21012102001	R3169M1	0613952R01
C3143M1	21667009366	R3170M1	0613952R01
C3144M1	2113945Y02	R3171M1	NOT PLACED
C3145M1	2113944C06	R3172M1	NOT PLACED
C3146M1	21012102001	R3173M1	0613952R66
C3149M1	2113956A51	R3174M1	0613952R66
C3150M1	2113956C37	R3175M1	0689774Y02
C3151M1	2113945B02	R3176M1	0689774Y02

Circuit Ref.	Motorola Solutions Part No.	Circuit Ref.	Motorola Solutions Part No.
C3152M1	2113944C06	R3177M1	0613952R66
C3153M1	2113946J04	R3178M1	0615871H01
C3154M1	2113955D13	R3179M1	0613952R17
C3155M1	2113945Y02	R3180M1	0613952R01
C3156M1	2113945Y02	R3181M1	NOT PLACED
C3157M1	2113945Y02	R3182M1	0613952R66
C3160M1	2113945Y02	R3183M1	0613952H92
C3161M1	NOT PLACED	R3184M1	0613952M30
C3171M1	2113946D07	R3200M1	0613952C44
C3173M1	2113946D07	R3201M1	0613952Q49
C3175M1	2113946A01	R3202M1	0613952C44
C3176M1	2113944C48	R3203M1	0613952Q49
C3177M1	2113946F08	R3204M1	0613952C44
C3200M1	21667009166	R3205M1	0613952C44
C3201M1	21667009166	R3206M1	0613952R01
C3203M1	2113955D37	R3207M1	0613952R01
C3204M1	2113955D37	R3208M1	0613952N30
C3205M1	21667009166	R3209M1	0613952R03
C3206M1	21667009166	R3210M1	0613952Q67
C3208M1	2113956C37	R3211M1	0613952N30
C3209M1	2113945Y02	R3212M1	0613952R03
C3210M1	2113945Y02	R3213M1	0613952Q42
C3211M1	2113945A11	R3214M1	0613952J25
C3212M1	2113955D37	R3215M1	0613952R01
C3213M1	2113945A03	R3216M1	0613952R17
C3214M1	2113955D37	R3217M1	0613952R01
C3215M1	2113956F49	R3218M1	0613952R01
C3216M1	2113945Y02	R3219M1	NOT PLACED
C3217M1	2113956B91	R3220M1	0613952R01
C3218M1	2113956A51	R3221M1	NOT PLACED
C3219M1	2113956A51	R3222M1	0613952R01
C3220M1	2113946F05	R3223M1	0613952R66
C3221M1	2113945Y02	R3224M1	NOT PLACED
C3222M1	2113956A51	R3225M1	NOT PLACED
C3223M1	2113945Y02	R3226M1	0613952R01

Circuit Ref.	Motorola Solutions Part No.	Circuit Ref.	Motorola Solutions Part No.
C3224M1	2113946F05	R3229M1	0613952R01
C3225M1	2113945Y02	R3230M1	0613952R10
C3226M1	NOT PLACED	R3231M1	0613952R10
C3227M1	2113946F05	R3232M1	0613952R10
C3228M1	2113945Y02	R3233M1	0613952R01
C3229M1	2113956A51	R3234M1	NOT PLACED
C3230M1	2113945Y02	R3235M1	0613952R01
C3231M1	2113945Y02	R3236M1	0613952R10
C3232M1	2113945Y02	R3237M1	NOT PLACED
C3233M1	2113945A09	R3238M1	0613952R01
C3234M1	2113945Y02	R3239M1	0613952Q49
C3235M1	21012102001	R3240M1	0613952R01
C3236M1	2113945C31	R3241M1	0613952M54
C3237M1	21009337414	R3242M1	0613952R01
C3238M1	2113945A09	R3243M1	0613952R01
C3239M1	2113945A09	R3244M1	0613952R10
C3240M1	2113956B91	R3245M1	NOT PLACED
C3241M1	2113956B91	R3246M1	0613952R01
C3242M1	2113945C31	R3247M1	0613952Q49
C3243M1	2113955D37	R3248M1	0613952R66
C3244M1	2113956B91	R3249M1	0613952R66
C3245M1	2113955D37	R3250M1	0613952R66
C3246M1	2113945C31	R3251M1	0613952R66
C3247M1	2113945Y02	R3252M1	0613952R66
C3248M1	2113945Y02	R3253M1	0613952R66
C3249M1	2113956B91	R3254M1	0613952R01
C3250M1	2113956B91	R3255M1	0613952R66
C4000M1	2113945Y02	R3256M1	0613952M66
C4001M1	2113945Y02	R3257M1	0613952R01
C4002M1	2113945Y02	R3258M1	0613952M66
C4003M1	2113945Y02	R3259M1	0613952M66
C4010M1	21667009166	R3260M1	0613952M66
C4011M1	21667009166	R3261M1	0613952R01
C4012M1	21667009166	R3262M1	0613952R10
C4013M1	21667009166	R3263M1	NOT PLACED

Circuit Ref.	Motorola Solutions Part No.	Circuit Ref.	Motorola Solutions Part No.
C4014M1	21667009166	R3264M1	0613952R01
C4015M1	21667009166	R3265M1	0613952M66
C4019M1	21667009166	R3266M1	0613952R01
C4020M1	21667009166	R3267M1	NOT PLACED
C4021M1	21667009166	R3268M1	0613952R01
C4022M1	21667009166	R3269M1	0613952M66
C4023M1	21667009166	R3270M1	0613952R01
C4025M1	21667009166	R3271M1	NOT PLACED
C4026M1	21667009166	R3272M1	0613952R01
C4027M1	21667009166	R3273M1	0613952M66
C4028M1	21667009166	R3274M1	0613952R10
C4029M1	21667009166	R3275M1	0613952R10
C4030M1	21667009166	R3276M1	0613952R10
C4100M1	21667009166	R3277M1	0613952R10
C4101M1	21667009166	R3278M1	0613952R01
C4103M1	21667009166	R3279M1	NOT PLACED
C4104M1	21667009166	R3280M1	NOT PLACED
C4105M1	21667009166	R3281M1	NOT PLACED
C4106M1	21667009166	R3282M1	0613952R66
C4107M1	21667009166	R3283M1	0613952R66
C4108M1	21667009166	R3285M1	0613952R01
C4109M1	21667009166	R3286M1	0613952R66
C4110M1	21667009166	R3287M1	0613952R66
C4112M1	21667009166	R3288M1	0613952R01
C4113M1	21667009166	R3289M1	0613952R01
C4114M1	21667009166	R3290M1	NOT PLACED
C4115M1	21667009166	R3291M1	NOT PLACED
C4116M1	21667009166	R3292M1	0613952R66
C4117M1	21667009166	R3293M1	0613952R66
C4118M1	21667009166	R4001M1	0613952R66
C4119M1	21667009166	R4003M1	0613952R66
C4200M1	2113945Y02	R4006M1	0613952Q37
C4201M1	2113945Y02	R4007M1	0613952Q37
C4202M1	21667009166	R4008M1	0613952R01
C4203M1	21667009166	R4010M1	0613952R01

Circuit Ref.	Motorola Solutions Part No.	Circuit Ref.	Motorola Solutions Part No.
C4204M1	NOT PLACED	R4013M1	0613952Q42
C4205M1	21667009166	R4015M1	0613952Q37
C4206M1	21667009166	R4021M1	0613952R66
C4207M1	21667009166	R4024M1	0613952R01
C4208M1	21667009166	R4025M1	0613952R01
C4209M1	21667009166	R4026M1	0613952R66
C4210M1	21667009166	R4027M1	0613952R66
C4211M1	21667009166	R4028M1	0613952R01
C4212M1	21667009166	R4029M1	0613952R01
C4213M1	21667009166	R4030M1	0613952R01
C4214M1	21667009166	R4031M1	0613952R01
C4218M1	21667009166	R4032M1	0613952R66
C4219M1	21667009339	R4033M1	0613952M43
C4220M1	21667009339	R4034M1	0613952M43
C4221M1	21667009339	R4035M1	0613952R66
C4222M1	21667009339	R4036M1	0613952R66
C4223M1	21667009339	R4037M1	0613952R01
C4224M1	21667009166	R4038M1	0613952R01
C4225M1	21667009166	R4039M1	NOT PLACED
C4226M1	21667009339	R4040M1	NOT PLACED
C4300M1	NOT PLACED	R4041M1	NOT PLACED
C4301M1	NOT PLACED	R4100M1	0613952R01
C4302M1	NOT PLACED	R4101M1	0613952Q77
C4303M1	NOT PLACED	R4102M1	0613958H83
C4304M1	21667009166	R4103M1	0613952Q85
C4305M1	21667009376	R4104M1	0613952Q89
C4306M1	21667009381	R4105M1	0613952Q89
C4307M1	NOT PLACED	R4106M1	0613952Q89
C4308M1	NOT PLACED	R4107M1	0613952R01
C4309M1	21667009166	R4108M1	0613952Q89
C4310M1	21667009166	R4109M1	0613952N58
C4311M1	2113945Y02	R4110M1	0613952Q85
C4312M1	2113945Y02	R4111M1	0613952Q85
C4313M1	21667009166	R4112M1	0613952R01
C4314M1	NOT PLACED	R4113M1	0613952R01

Circuit Ref.	Motorola Solutions Part No.	Circuit Ref.	Motorola Solutions Part No.
C4401M1	NOT PLACED	R4114M1	0613952Q89
C4402M1	NOT PLACED	R4115M1	0613952N58
C4403M1	NOT PLACED	R4116M1	0613952Q89
C4404M1	NOT PLACED	R4117M1	0613952R01
C4405M1	NOT PLACED	R4118M1	0613952R01
C4406M1	NOT PLACED	R4119M1	0613952R01
C4407M1	NOT PLACED	R4120M1	0613952N58
C4408M1	NOT PLACED	R4121M1	0613952Q85
C4409M1	NOT PLACED	R4122M1	0613952Q85
C4410M1	NOT PLACED	R4123M1	0613952N58
C4411M1	NOT PLACED	R4124M1	0613952N58
C4412M1	21667009166	R4125M1	0613952Q85
C4413M1	21667009166	R4126M1	0613952Q85
C4414M1	21667009166	R4127M1	0613952Q85
C4415M1	21667009166	R4128M1	0613952R01
C4417M1	21667009166	R4200M1	0613952R66
C4418M1	21667009166	R4201M1	0613952R66
C4419M1	21667009166	R4202M1	0613952R66
D0000M2	4815011H01	R4203M1	0613952R66
D0001M2	4815011H01	R4204M1	0613952R66
D0400M4	4884800Y03	R4205M1	0613952R66
D0401M4	4813974A19	R4206M1	0613952R66
D0402M4	4813974A19	R4207M1	0613952R66
D0403M4	4884800Y03	R4208M1	0613952R66
D0404M4	4815090H01	R4209M1	HZ000375A01
D0500M3	4813974A19	R4210M1	HZ000375A01
D0700M6	NOT PLACED	R4211M1	HZ000375A01
D0701M6	48012160001	R4212M1	HZ000375A01
D0875M6	48012160001	R4213M1	HZ000375A01
D0876M6	4886622Y06	R4214M1	HZ000375A01
D0900M6	NOT PLACED	R4215M1	0613952R66
D0950M6	4813974A21	R4216M1	0613952R66
D0951M6	4813974A21	R4217M1	0613952R66
D3000M6	4813978P07	R4218M1	0613952R66
D3104M1	4885489Y01	R4301M1	NOT PLACED

Circuit Ref.	Motorola Solutions Part No.	Circuit Ref.	Motorola Solutions Part No.
D3160M1	4813978C02	R4302M1	0613952R66
D3161M1	4813978C02	R4303M1	0613952R66
E0000M2	24012107027	R4304M1	0613952R66
E0001M2	24012107027	R4305M1	0613952R66
E0002M2	NOT PLACED	R4306M1	0613952R66
E0003M2	24012107027	R4307M1	0613952R66
E0004M2	24012107027	R4309M1	NOT PLACED
E0005M2	24012107027	R4310M1	0613952R66
E0006M2	24012107027	R4311M1	0613952R66
E0007M2	24012107027	R4312M1	0613952R66
E0008M2	24012107027	R4313M1	NOT PLACED
E0009M2	24012107027	R4314M1	0613952R66
E0010M2	24012107027	R4315M1	0613952R66
E0300M7	24012107027	R4316M1	0613952R66
E0301M7	24012107027	R4317M1	0613952R66
E0401M4	24012107027	RT0900M6	0615585H01
E0402M4	24012107027	SH0000M2	26012095001
E0403M4	24012107027	SH0001M2	26012095001
E0404M4	24012107027	SH0002M2	26012097001
E0500M3	24012107027	SH0003M2	26012094001
E0700M6	24012102001	SH0004M2	26012094001
E0701M6	24012102001	SH0200M7	26012095001
E0703M6	24012102001	SH0300M7	26012231001
E1000M1	7686949J15	SH0400M4	26012096001
E1001M1	7686949J15	SH0401M4	26012096001
E1002M1	7686949J15	SH0402M4	26012098001
E1003M1	7686949J15	SH0403M4	26012098001
E1004M1	7686949J15	SH0500M3	26012098001
E1005M1	7686949J15	SH0700M6	26012100001
E1006M1	7685268E01	SH0900M6	2686425Z02
E3000M6	24012102001	SH0901M6	2686425Z02
E3100M1	24012102001	SH3100M1	NOT PLACED
E3101M1	2485410Y02	SP3000M6	NOT PLACED
E3102M1	2485410Y02	SP3001M6	NOT PLACED
E3103M1	2485410Y02	T0000M2	25012016001

Circuit Ref.	Motorola Solutions Part No.	Circuit Ref.	Motorola Solutions Part No.
E3104M1	7686949J22	T0400M4	2515121H01
E3105M1	7686949J22	T0401M4	2515121H01
E3106M1	7686949J22	U0000M2	51009877001
E3107M1	7686949J22	U0001M2	5109731C48
E3108M1	7686949J22	U0002M2	4802197J95
E3109M1	7686949J22	U0300M7	5186310Y39
E3110M1	7686949J22	U0500M3	4802197J95
E3111M1	7686949J22	U0700M6	NOT PLACED
E3113M1	7686949J22	U0901M6	5180390L83
E3200M1	24012102001	U0902M6	51012221001
E3201M1	24012102001	U0903M6	5115022H01
E3202M1	24012107027	U0904M6	5109731C48
E3203M1	24012102001	U1000M1	5171320H01
E3204M1	24012102001	U1001M1	51012295001
E4000M1	24012107027	U1002M1	5189139P01
E4001M1	7688697V05	U1003M1	5175772B56
E4002M1	24012107027	U1004M1	5175772B56
E4003M1	NOT PLACED	U1005M1	5164852H47
E4004M1	24012102001	U1006M1	5185493Y01
E4005M1	2485410Y02	U1007M1	5189139P01
E4100M1	7686949J14	U1008M1	5189139P01
E4101M1	24012107027	U1009M1	5115001H02
E4102M1	NOT PLACED	U1010M1	5171320H01
E4103M1	NOT PLACED	U2000M1	MM000157A01
E4104M1	NOT PLACED	U2001M1	MM000129A01
E4200M1	24012107027	U3000M6	5116525H01
E4201M1	24012107027	U3001M6	4813973M07
E4202M1	24012107027	U3002M6	51012133001
E4300M1	24012107027	U3100M1	0104039J08
E4405M1	24012107027	U3101M1	5114014A01
E4406M1	7686949J22	U3102M1	51012069001
E4407M1	7686949J22	U3103M1	51012142001
E4408M1	24012107027	U3104M1	5171590Y73
E4409M1	24012102001	U3105M1	5114610F01
F4000M1	65012019001	U3106M1	51012140001

Circuit Ref.	Motorola Solutions Part No.	Circuit Ref.	Motorola Solutions Part No.
FL0500M3	9180022M11	U3107M1	51012140001
FL4000M1	24012038001	U3108M1	51012138001
FL4001M1	24012038001	U3109M1	5164015H94
J4000M1	0915767H01	U3110M1	51012208001
J4001M1	0915556H01	U3111M1	5188690V02
J4100M1	0916017H01	U3112M1	5114004A35
J4200M1	09012053001	U3113M1	5188690V02
J4400M1	09012053001	U3114M1	NOT PLACED
L0000M2	24012154001	U3115M1	5185937Y01
L0001M2	24667008031	U3200M1	51009415001
L0002M2	24667000031	U3201M1	5114016A18
L0003M2	24667008031	U3204M1	51009509001
L0004M2	24009343004	U3205M1	5114016A18
L0005M2	24667008021	U4000M1	51012082001
L0200M7	24667000031	U4001M1	51012082001
L0201M7	24667000031	U4100M1	5189139P01
L0202M7	2416077H14	U4200M1	NOT PLACED
L0203M7	24009344123	U4201M1	NOT PLACED
L0204M7	24667005040	U4300M1	51012082001
L0205M7	24667000031	U4301M1	51012082001
L0206M7	24667005040	VR0001M2	4815096H01
L0207M7	24667000031	VR0200M7	48012260001
L0208M7	24667000031	VR0201M7	4805656W87
L0209M7	24667000031	VR0202M7	4815002H03
L0210M7	24009342045	VR0203M7	4805656W87
L0211M7	2414015C11	VR0205M7	4805656W87
L0300M7	24667008018	VR0206M7	48012260001
L0301M7	24667008031	VR0207M7	4805656W87
L0302M7	24667008031	VR0208M7	4815002H03
L0303M7	24667008013	VR0209M7	4805656W87
L0304M7	24667008019	VR0400M4	4805656W87
L0305M7	24667008016	VR0401M4	4805656W87
L0306M7	24667008025	VR0402M4	4805656W87
L0307M7	24667008031	VR0403M4	4805656W87
L0308M7	24667008024	VR0404M4	4805656W87

Circuit Ref.	Motorola Solutions Part No.	Circuit Ref.	Motorola Solutions Part No.
L0401M4	24009343017	VR0405M4	4805656W87
L0402M4	24009344115	VR0406M4	4805656W87
L0403M4	24667000031	VR0407M4	4805656W87
L0404M4	24009344114	VR3000M6	48012202001
L0405M4	24009344127	VR3002M6	4813977M10
L0406M4	24009343017	VR3103M1	48012095001
L0407M4	24009343017	VR3104M1	48012095002
L0408M4	24667000031	VR3105M1	4813977M10
L0409M4	24667000031	VR3200M1	48012049001
L0410M4	24009344127	VR3201M1	4813977A48
L0411M4	24009343017	VR3202M1	4813977A48
L0414M4	24009344113	VR4000M1	4813977M13
L0415M4	24009344114	VR4001M1	4813977A48
L0416M4	NOT PLACED	VR4002M1	48012153001
L0417M4	24009344115	VR4100M1	4813977A48
L0418M4	NOT PLACED	VR4101M1	4813977A48
L0421M4	24009344115	VR4102M1	4813977A48
L0424M4	24009344115	VR4103M1	4813977A48
L0428M4	24009344113	VR4104M1	48012049001
L0434M4	24667008028	VR4105M1	4813977M13
L0462M4	24667000031	VR4106M1	4813977A48
L0463M4	24667000031	VR4107M1	4813977A48
L0500M3	24667005045	VR4108M1	4813977A48
L0501M3	NOT PLACED	VR4109M1	4813977A50
L0502M3	24667000031	VR4110M1	4815040H01
L0504M3	24667000031	VR4111M1	48012153001
L0505M3	24667000031	Y0000M2	4875185M05



NOTICE: The suffix "M1", "M2", and so on from the Circuit Ref. is removed from the schematic and overlays.

8.4.1.3

Circuit Board and Schematic Diagrams for 84012736002-B

Figure 164: Main Board Top Side PCB No. 84012736002-B

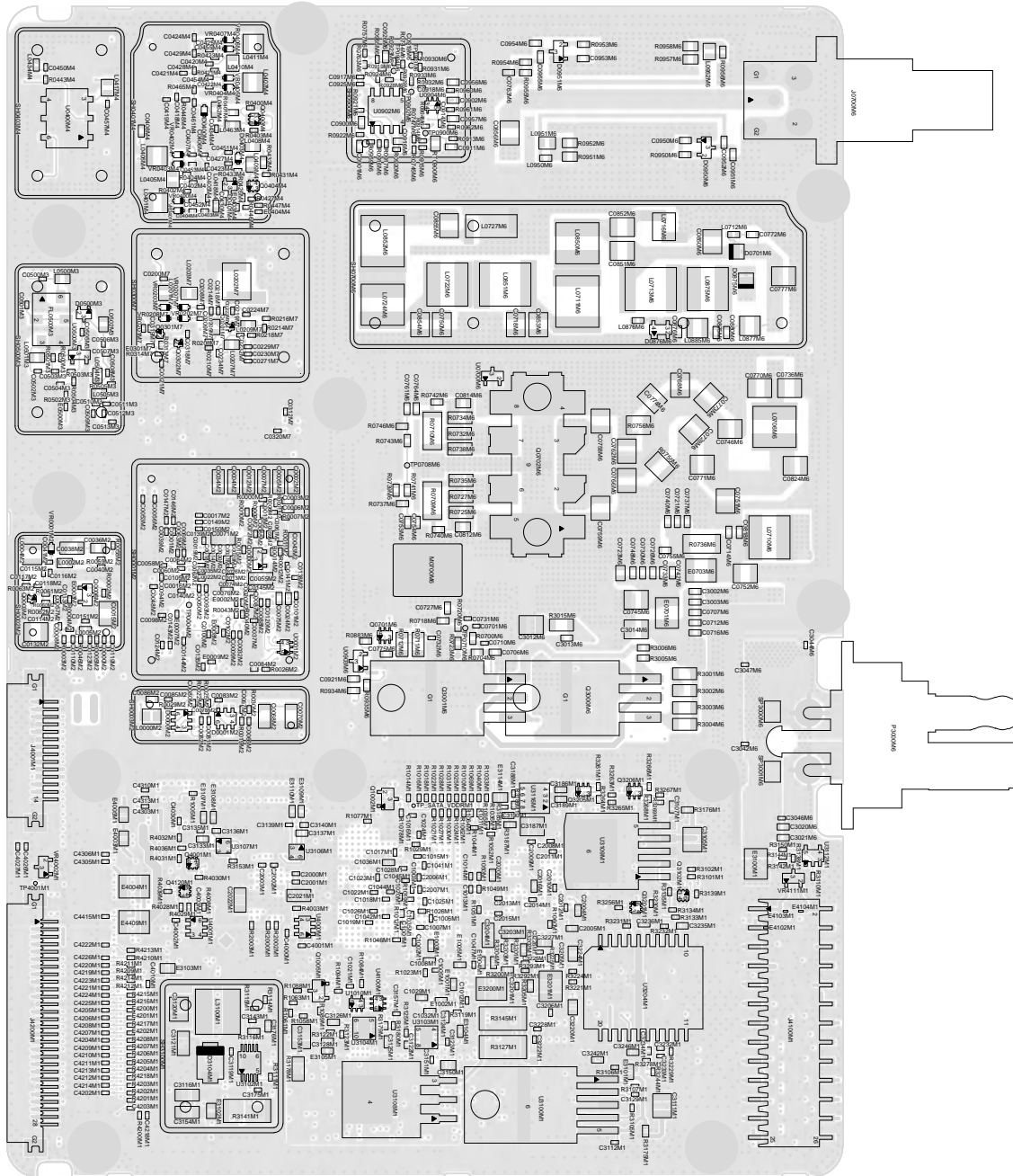

Figure 165: Main Board Bottom Side PCB No. 84012736002-B

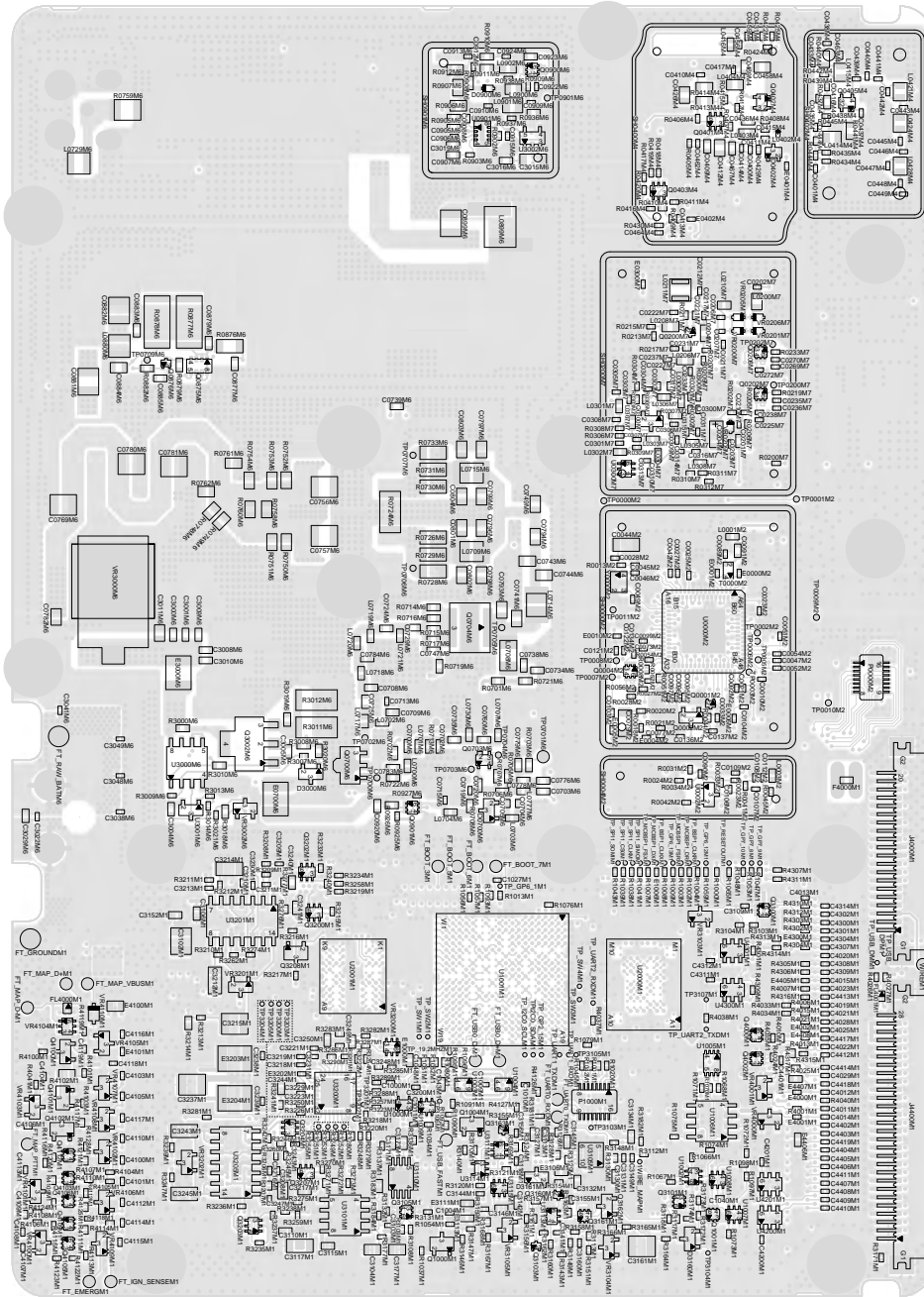

Figure 166: Overall Schematic Diagram

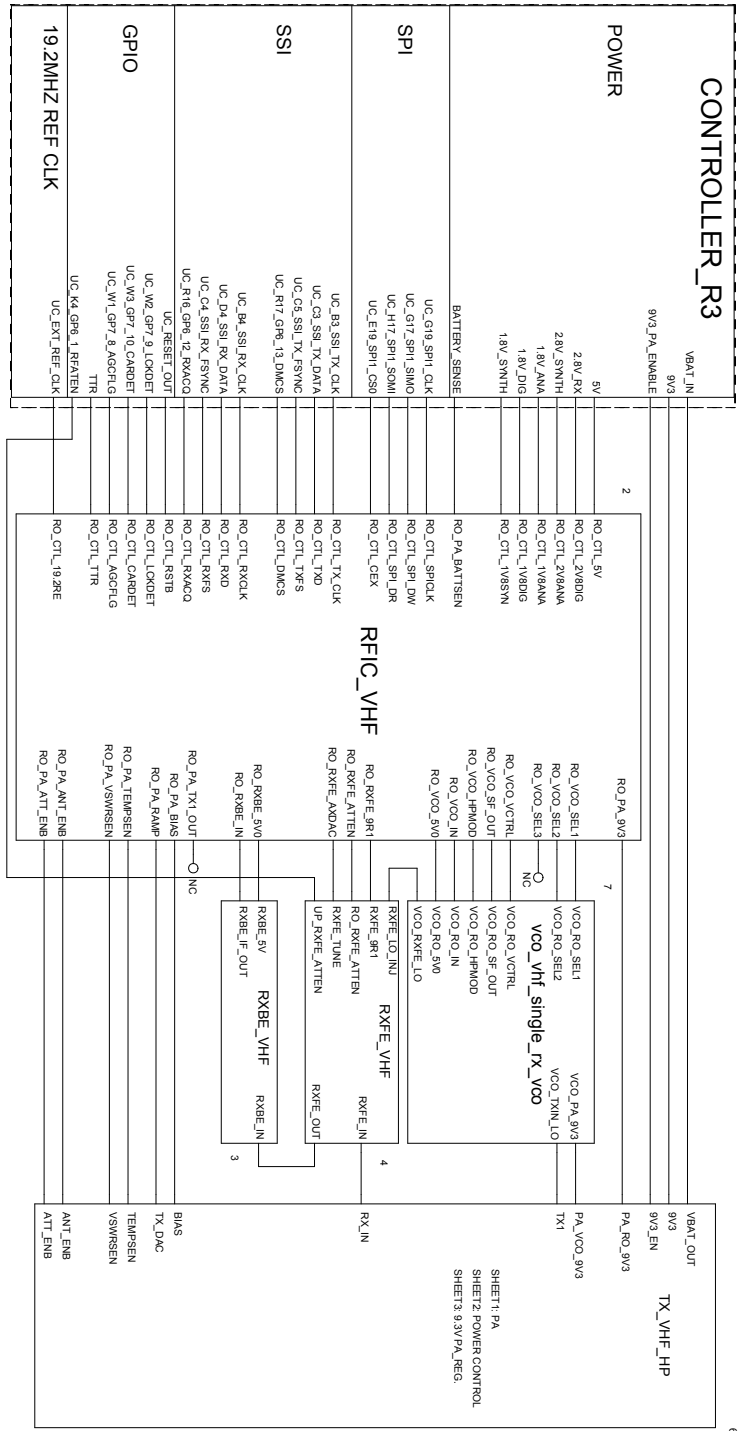

Figure 167: Receiver Front End Schematic Diagram

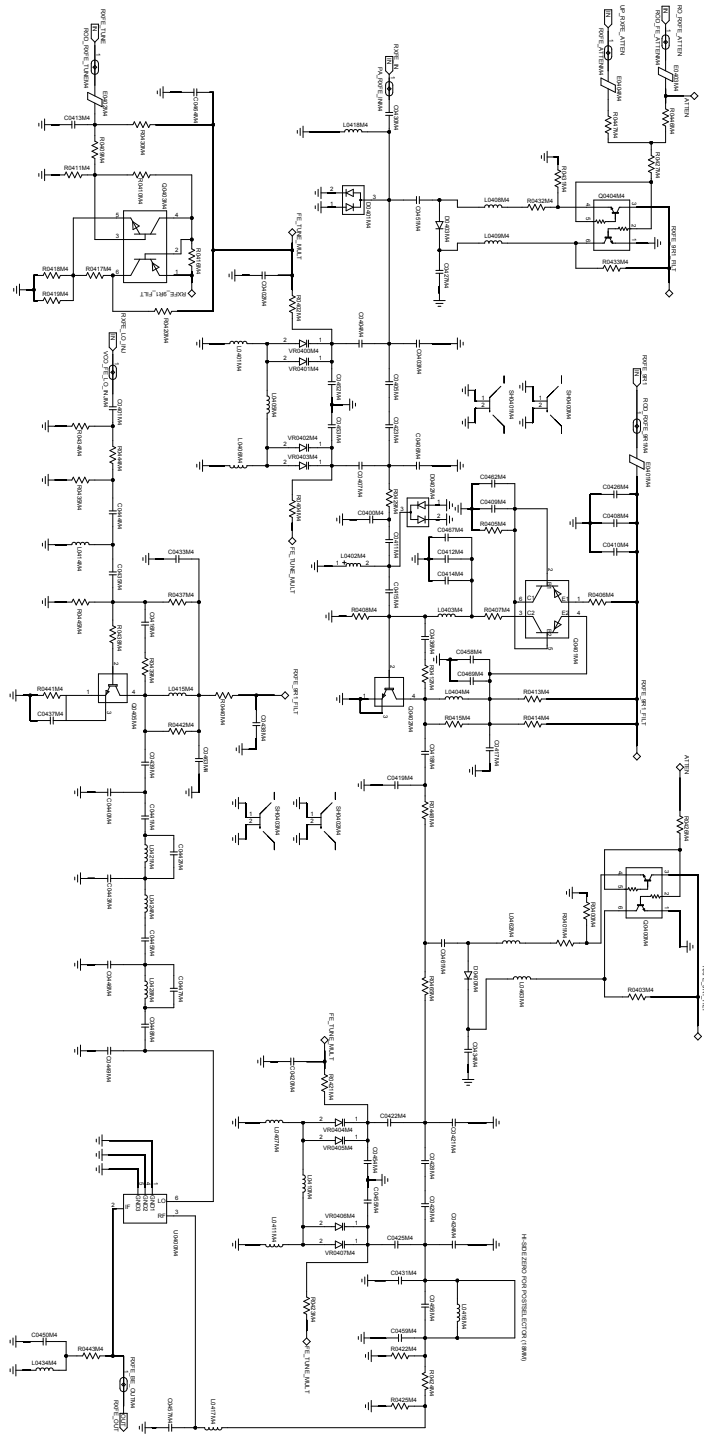

Figure 168: Receiver IF Amp Schematic Diagram

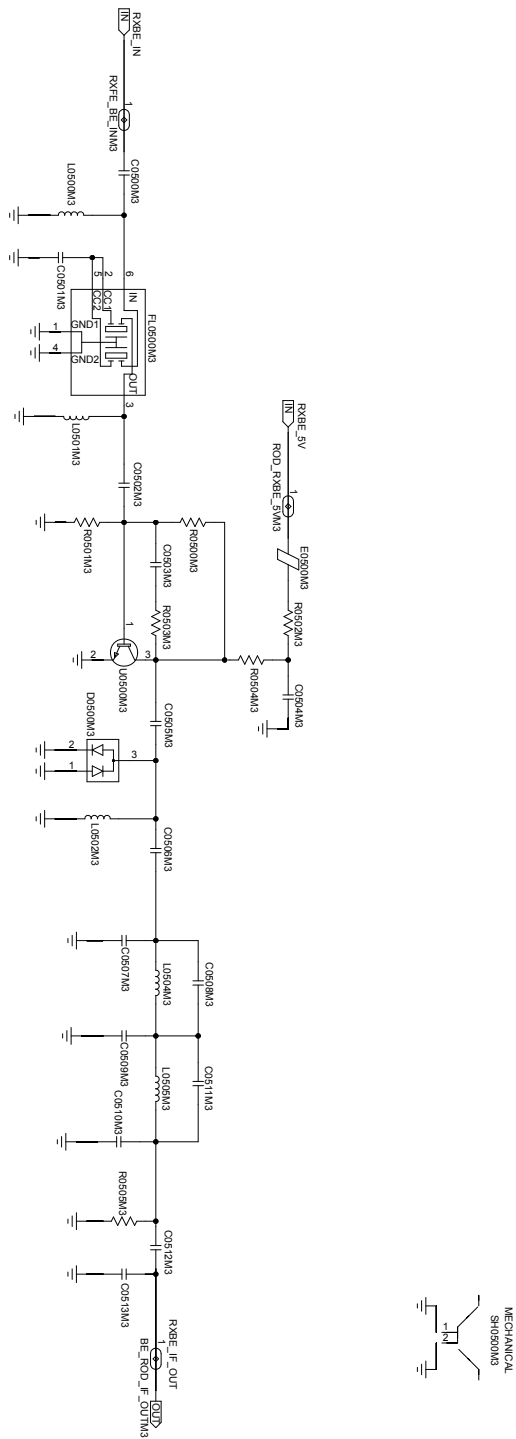

Figure 169: Transmitter Power Amplifier Schematic Diagram

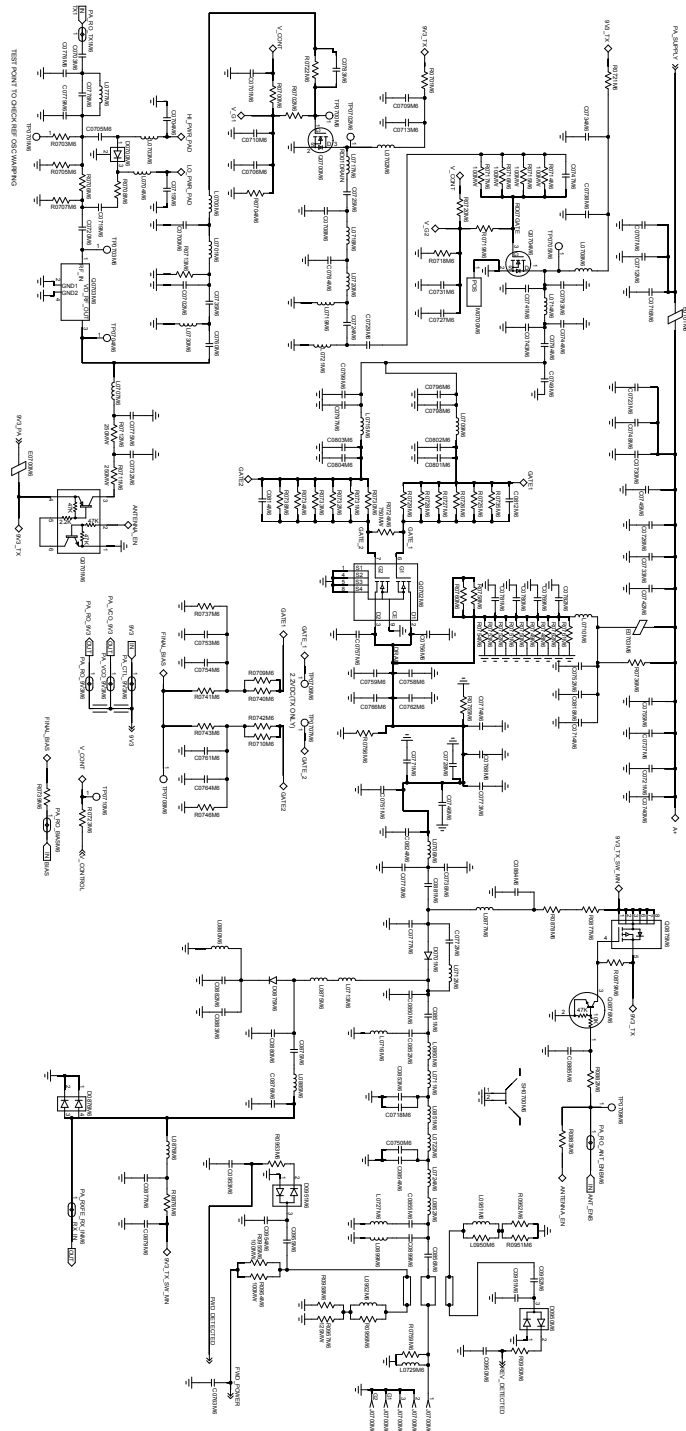

Figure 170: Power Control Schematic Diagram

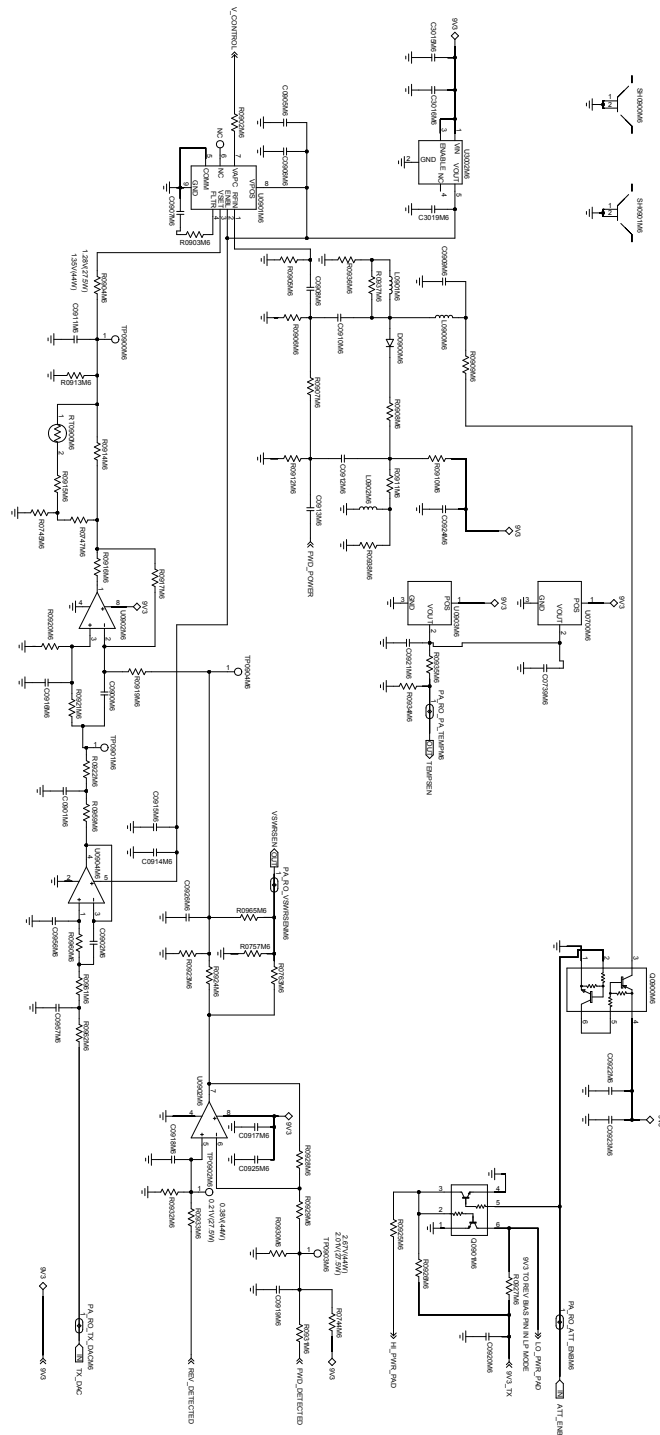

Figure 171: Transmitter Power Amplifier DC Distribution Schematic Diagram

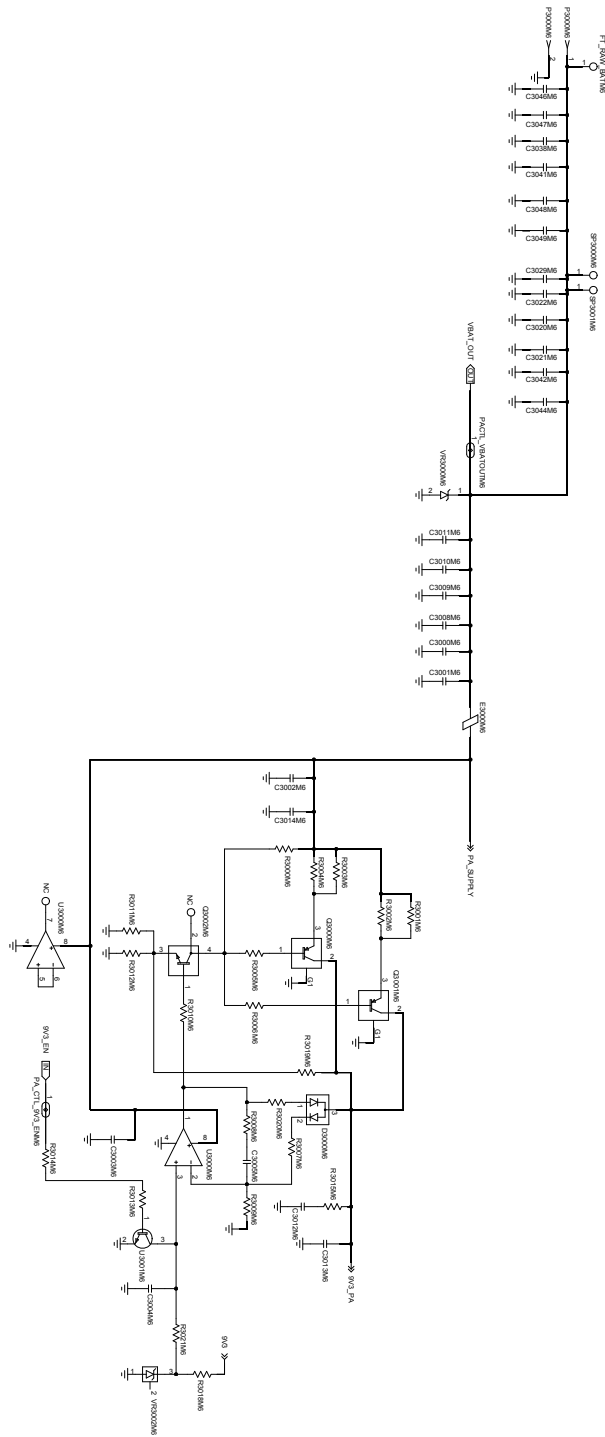

Figure 172: RFIC Schematic Diagram

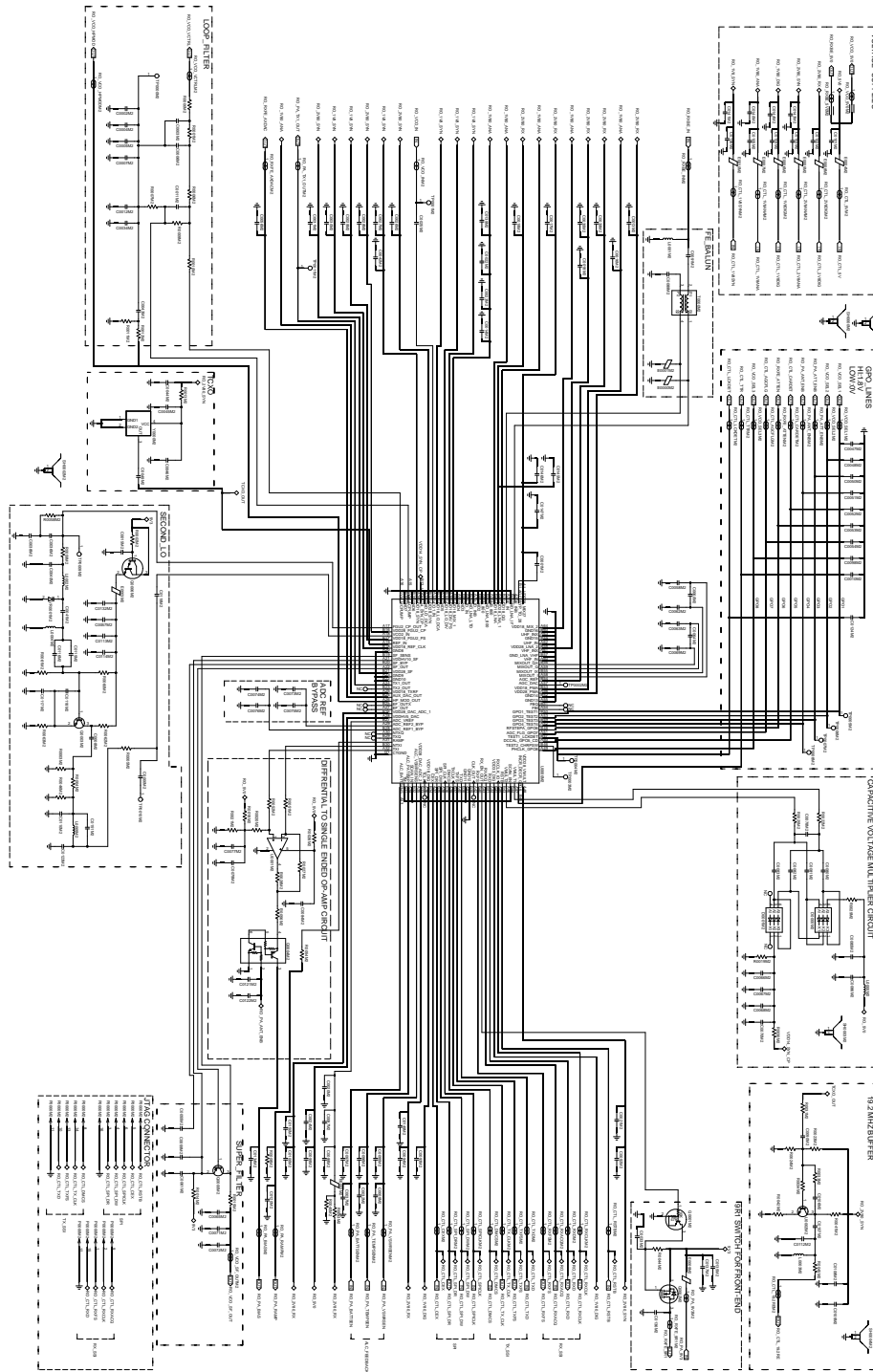

Figure 173: Receiver VCO Schematic Diagram

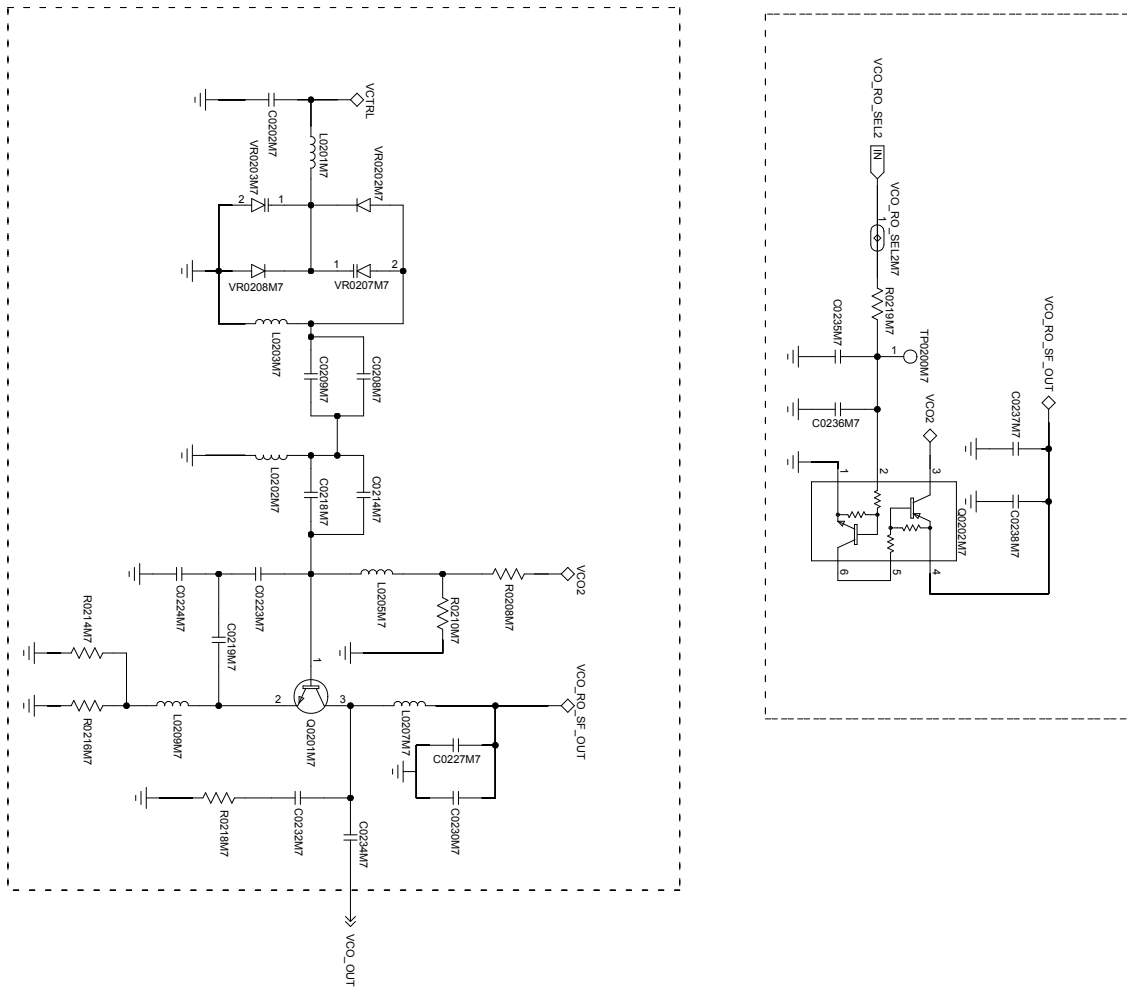

Figure 174: Transmit VCO Schematic Diagram

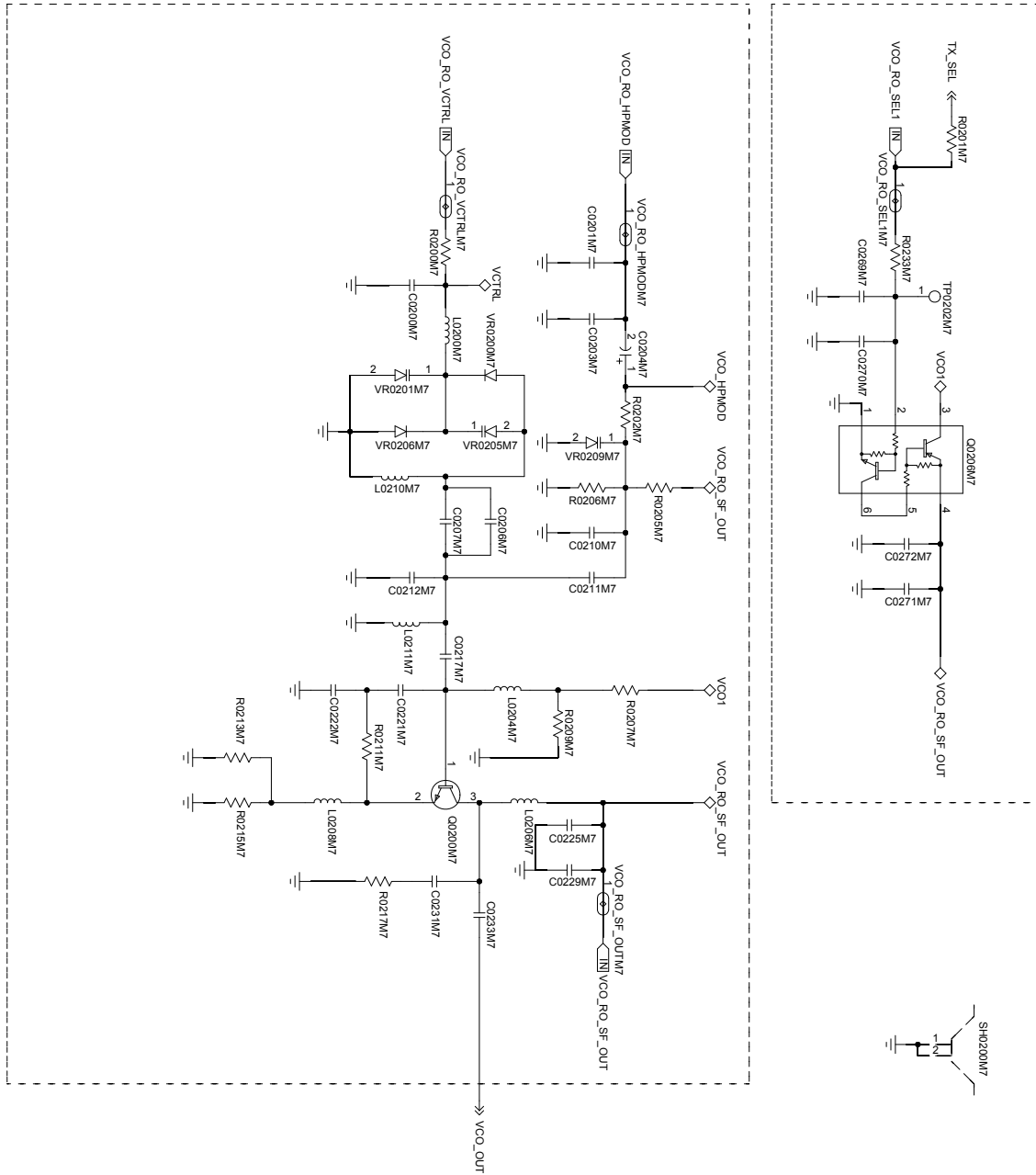
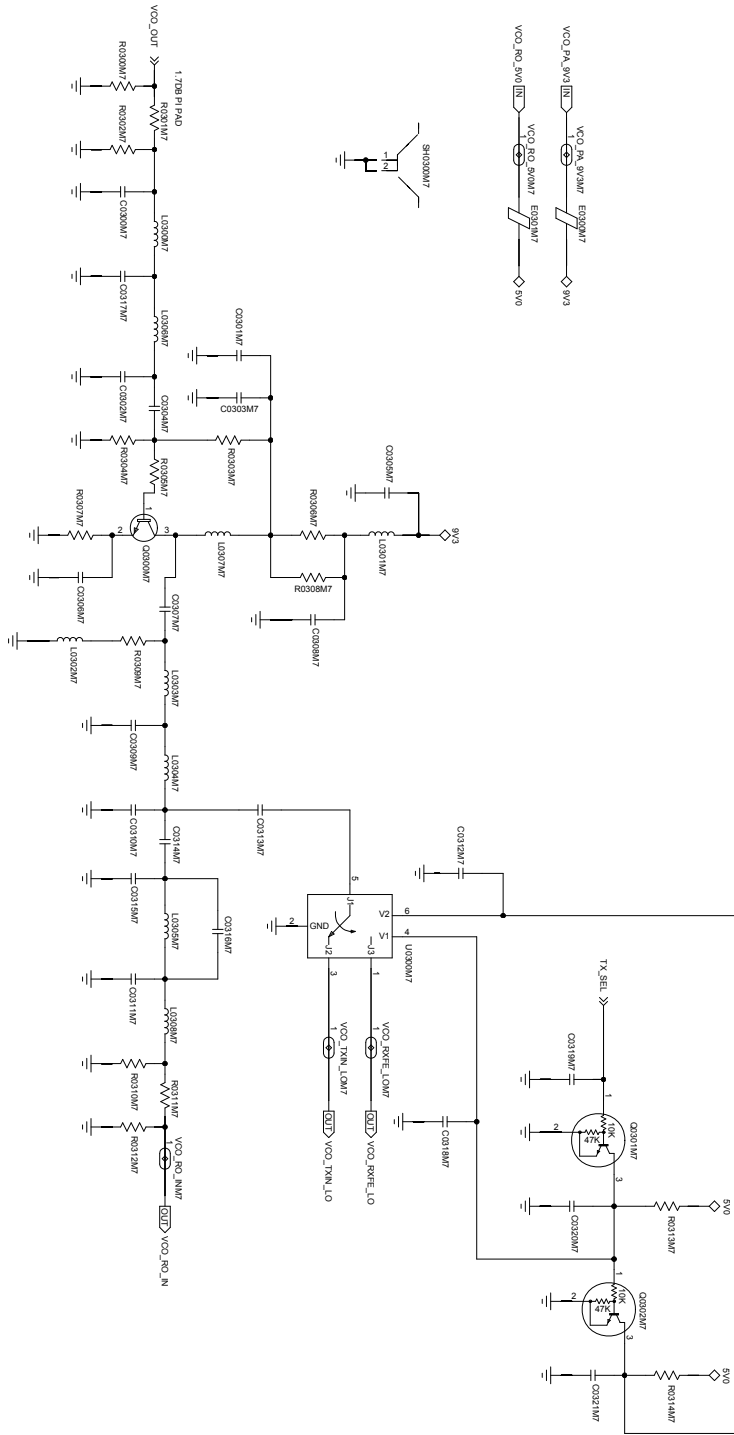

Figure 175: VCO Buffer Schematic Diagram



8.4.1.4

Parts List for 84012736002-B

Table 20: VHF Radio Parts List

Circuit Ref.	Motorola Solutions Part No.	Circuit Ref.	Motorola Solutions Part No.
C0000M2	21667009311	E0009M2	24012107027
C0001M2	21667009170	E0010M2	24012107027
C0002M2	21012044001	E0300M7	24012107027
C0003M2	NOT PLACED	E0301M7	24012107027
C0004M2	21012044001	E0401M4	24012107027
C0005M2	21012044001	E0402M4	24012107027
C0006M2	2113945C31	E0403M4	24012107027
C0007M2	21012044001	E0404M4	24012107027
C0008M2	21667009355	E0500M3	24012107027
C0009M2	21667009166	E0700M6	24012102001
C0010M2	2113945A10	E0701M6	24012102001
C0011M2	2113945C31	E0703M6	24012102001
C0012M2	21012044001	E3000M6	24012102001
C0013M2	2113945Y02	FL0500M3	9180022M11
C0014M2	2113945Y02	J0700M6	09009348002
C0015M2	2113946J03	L0000M2	24012154001
C0016M2	2113945A10	L0001M2	24667008031
C0017M2	2113945Y02	L0002M2	24667000031
C0018M2	2113945A10	L0003M2	24667008031
C0019M2	2113945Y02	L0004M2	24009343004
C0020M2	2113945A10	L0005M2	24667008021
C0021M2	2113945Y02	L0200M7	24667000031
C0022M2	2113945Y02	L0201M7	24667000031
C0023M2	2113945Y02	L0202M7	2416077H14
C0024M2	21012102001	L0203M7	24009344123
C0025M2	2113945A10	L0204M7	24667005040
C0026M2	21667009174	L0205M7	24667000031
C0027M2	2113945Y02	L0206M7	24667005040
C0028M2	2113945Y02	L0207M7	24667000031
C0029M2	2113945A10	L0208M7	24667000031
C0030M2	2113945A10	L0209M7	24667000031
C0031M2	2113945Y02	L0210M7	24009342045

Circuit Ref.	Motorola Solutions Part No.	Circuit Ref.	Motorola Solutions Part No.
C0032M2	21667009166	L0211M7	2414015C11
C0033M2	NOT PLACED	L0300M7	24667008018
C0034M2	21012044001	L0301M7	24667008031
C0035M2	2113945A10	L0302M7	24667008031
C0036M2	21012044004	L0303M7	24667008013
C0037M2	21667009166	L0304M7	24667008019
C0038M2	21012044001	L0305M7	24667008016
C0039M2	2113945Y02	L0306M7	24667008025
C0040M2	2113945A10	L0307M7	24667008031
C0041M2	21667009366	L0308M7	24667008024
C0042M2	21667009166	L0401M4	24009343017
C0043M2	21012044001	L0402M4	2475122C33
C0044M2	2113955D45	L0403M4	24667000031
C0045M2	2113945Y02	L0404M4	24667005043
C0046M2	21667009166	L0405M4	24009344127
C0047M2	2113945A10	L0406M4	24009343017
C0048M2	2113945A10	L0407M4	24009343017
C0049M2	2113945B02	L0408M4	24667000031
C0050M2	2113945A10	L0409M4	24667000031
C0051M2	2113945A10	L0410M4	24009344127
C0052M2	2113945A10	L0411M4	24009343017
C0053M2	2113945A10	L0414M4	24009344113
C0054M2	2113945A10	L0415M4	24009344114
C0055M2	2113955D37	L0416M4	NOT PLACED
C0056M2	2113945Y02	L0417M4	24009344110
C0057M2	2113945B02	L0418M4	NOT PLACED
C0058M2	NOT PLACED	L0421M4	24009344115
C0059M2	21667009166	L0424M4	24009344115
C0060M2	2113945A69	L0428M4	24009344113
C0061M2	2113945Y02	L0434M4	24667008028
C0062M2	NOT PLACED	L0462M4	24667000031
C0063M2	NOT PLACED	L0463M4	24667000031
C0064M2	2113945A69	L0500M3	24667005045
C0065M2	2113945Y02	L0501M3	NOT PLACED
C0066M2	2113945B02	L0502M3	24667000031

Circuit Ref.	Motorola Solutions Part No.	Circuit Ref.	Motorola Solutions Part No.
C0067M2	2113945Y02	L0504M3	24667000031
C0068M2	2113955D37	L0505M3	24667000031
C0069M2	NOT PLACED	L0700M6	24667008024
C0070M2	2113955D37	L0701M6	24667008020
C0071M2	2113955D37	L0702M6	24667008028
C0072M2	21667009166	L0703M6	NOT PLACED
C0073M2	21667009166	L0704M6	NOT PLACED
C0074M2	21667009166	L0706M6	2485873L01
C0075M2	2113946S35	L0707M6	24667008031
C0076M2	2113946S35	L0708M6	2479990G01
C0077M2	21667009166	L0709M6	2460591A01
C0078M2	21667009372	L0710M6	2485873L01
C0079M2	2113955D37	L0711M6	2485873L02
C0080M2	2113945B02	L0712M6	NOT PLACED
C0081M2	2113945B02	L0713M6	2485873L02
C0082M2	2113945B02	L0714M6	2460591A01
C0083M2	2113945B02	L0715M6	2460591A01
C0084M2	21667009166	L0716M6	2415385H02
C0085M2	2113945A10	L0717M6	24667008016
C0086M2	2113945C31	L0718M6	24667008020
C0087M2	2113946S35	L0719M6	24667008019
C0088M2	2113945Y02	L0720M6	24667008016
C0089M2	2113945Y02	L0721M6	24667008014
C0090M2	2113945B02	L0722M6	2485873L01
C0091M2	2113944C45	L0724M6	2485873L01
C0092M2	2113945A10	L0727M6	2415385H07
C0093M2	2113945Y02	L0729M6	2414032B60
C0094M2	2113945Y02	L0730M6	24667008021
C0095M2	2113945A13	L0777M6	24667008020
C0096M2	2113945B02	L0850M6	2485873L01
C0097M2	2113945B02	L0851M6	2485873L02
C0098M2	2113945A10	L0852M6	2485873L02
C0099M2	2113945Y02	L0875M6	2485873L01
C0100M2	2113945Y02	L0876M6	24667008031
C0101M2	2113945A10	L0877M6	24009343030

Circuit Ref.	Motorola Solutions Part No.	Circuit Ref.	Motorola Solutions Part No.
C0102M2	2113945A10	L0880M6	24009343030
C0103M2	2113945A10	L0885M6	2414032B49
C0104M2	2113945A10	L0899M6	2416077H16
C0105M2	2113945A10	L0900M6	NOT PLACED
C0106M2	2113945B02	L0901M6	NOT PLACED
C0107M2	2113945B02	L0902M6	NOT PLACED
C0108M2	2113945A10	L0950M6	0613952G67
C0109M2	2113945Y02	L0951M6	NOT PLACED
C0110M2	21667009381	L0952M6	NOT PLACED
C0112M2	21667009166	M0700M6	2686201B02
C0113M2	2113945A10	P0000M2	NOT PLACED
C0114M2	2113945Y02	P3000M6	9009344001
C0115M2	21667009372	Q0000M2	4813973A13
C0116M2	NOT PLACED	Q0001M2	48009494001
C0117M2	21667009388	Q0002M2	4813970A59
C0118M2	21667009378	Q0003M2	4885316E32
C0119M2	2113945A10	Q0004M2	4815272H01
C0120M2	2113945A10	Q0006M2	4813973A04
C0121M2	NOT PLACED	Q0200M7	4885316E32
C0122M2	21667009166	Q0201M7	4885316E32
C0123M2	21667009381	Q0202M7	4815272H01
C0124M2	21667009166	Q0206M7	4815272H01
C0132M2	2113946J03	Q0300M7	4802197J95
C0134M2	2113945A10	Q0301M7	48009494001
C0135M2	21667009166	Q0302M7	48009494001
C0136M2	21667009166	Q0400M4	4815271H01
C0137M2	2113945Y02	Q0401M4	4815267H01
C0138M2	2113945A10	Q0402M4	48012201001
C0139M2	2113945A10	Q0403M4	4815270H01
C0140M2	2113945Y02	Q0404M4	4815271H01
C0141M2	2113945Y02	Q0405M4	48012201001
C0143M2	2113945Y02	Q0700M6	CR001114A01
C0144M2	2113945Y02	Q0701M6	4816013H01
C0145M2	21667009166	Q0702M6	CR001118A01
C0146M2	2113945A10	Q0703M6	4802246J29

Circuit Ref.	Motorola Solutions Part No.	Circuit Ref.	Motorola Solutions Part No.
C0147M2	2113945A10	Q0704M6	CR001116A01
C0149M2	2113945A10	Q0875M6	4813970A62
C0150M2	2113945A10	Q0876M6	48009494001
C0151M2	21667009372	Q0900M6	NOT PLACED
C0200M7	2113945A10	Q0901M6	NOT PLACED
C0201M7	NOT PLACED	Q3000M6	0105959T72
C0202M7	2113945A10	Q3001M6	0105959T72
C0203M7	NOT PLACED	Q3002M6	4813973B01
C0204M7	NOT PLACED	R0000M2	0613952R66
C0206M7	21667009355	R0001M2	0613952R66
C0207M7	21667009355	R0002M2	0613952Q96
C0208M7	21667009366	R0003M2	0613952Q57
C0209M7	21667009366	R0004M2	0613952Q34
C0210M7	21667009274	R0005M2	0613952R66
C0211M7	NOT PLACED	R0006M2	0613952Q25
C0212M7	NOT PLACED	R0007M2	0613952Q51
C0214M7	21667009320	R0008M2	0613952R01
C0217M7	21667009204	R0009M2	0613952Q58
C0218M7	21667009315	R0010M2	0613952R66
C0219M7	2113945A04	R0011M2	0613952Q35
C0221M7	21667009371	R0012M2	0613952Q81
C0222M7	21667009374	R0013M2	0613952Q35
C0223M7	21667009378	R0014M2	0613952R66
C0224M7	21667009377	R0015M2	0613952R66
C0225M7	2113945Y02	R0018M2	0613952Q80
C0227M7	2113945Y02	R0019M2	0613952R01
C0229M7	2113945A10	R0020M2	0613952R12
C0230M7	2113945A10	R0021M2	0613952Q80
C0231M7	2113945A10	R0022M2	0613952R66
C0232M7	2113945A10	R0023M2	0613952Q83
C0233M7	21667009284	R0024M2	0613952Q80
C0234M7	21667009284	R0025M2	0613952R66
C0235M7	2113945A10	R0026M2	0613952R66
C0236M7	2113945Y02	R0027M2	0613952R12
C0237M7	2113945A10	R0028M2	0613952R66

Circuit Ref.	Motorola Solutions Part No.	Circuit Ref.	Motorola Solutions Part No.
C0238M7	2113945Y02	R0029M2	0613952Q25
C0269M7	2113945A10	R0030M2	0613952R66
C0270M7	2113945Y02	R0031M2	0613952R66
C0271M7	2113945A10	R0033M2	0613952R01
C0272M7	2113945Y02	R0034M2	0613952Q57
C0300M7	21667009378	R0040M2	0613952Q70
C0301M7	NOT PLACED	R0041M2	0613952Q58
C0302M7	21667009300	R0042M2	0613952Q42
C0303M7	NOT PLACED	R0043M2	0613952Q73
C0304M7	21667009392	R0044M2	0613952R25
C0305M7	2113945Y02	R0045M2	0613952R66
C0306M7	2113945A09	R0046M2	0613952Q57
C0307M7	2113945A02	R0051M2	0613952R01
C0308M7	NOT PLACED	R0052M2	0613952R01
C0309M7	21667009370	R0054M2	0613952M25
C0310M7	NOT PLACED	R0056M2	0613952R66
C0311M7	21667009368	R0058M2	0613952Q81
C0312M7	2113945A10	R0059M2	0613952R66
C0313M7	2113945A10	R0060M2	0613952Q86
C0314M7	21667009366	R0061M2	0613952Q85
C0315M7	21667009315	R0062M2	0613952Q61
C0316M7	21667009371	R0063M2	0613952Q64
C0317M7	21667009377	R0200M7	0613952R66
C0318M7	2113945A10	R0201M7	0613952R66
C0319M7	2113945A10	R0202M7	0613952R27
C0320M7	2113945A10	R0205M7	0613952R07
C0321M7	2113945A10	R0206M7	0613952R05
C0400M4	NOT PLACED	R0207M7	0613952Q86
C0401M4	2113945A10	R0208M7	0613952Q78
C0402M4	2113945A10	R0209M7	0613952Q85
C0403M4	21667009291	R0210M7	0613952Q73
C0404M4	21667009385	R0211M7	0613952Q18
C0405M4	21667009282	R0213M7	0613952Q67
C0406M4	21667009291	R0214M7	0613952Q67
C0407M4	21667009385	R0215M7	0613952Q67

Circuit Ref.	Motorola Solutions Part No.	Circuit Ref.	Motorola Solutions Part No.
C0408M4	2113945C31	R0216M7	0613952Q67
C0409M4	2113945C31	R0217M7	0613952Q49
C0410M4	2113945A10	R0218M7	0613952Q49
C0411M4	2113945A10	R0219M7	0613952R66
C0412M4	2113946F05	R0233M7	0613952R66
C0413M4	21667009166	R0300M7	0613952Q66
C0414M4	2113945A10	R0301M7	0613952Q25
C0415M4	21667009376	R0302M7	0613952Q66
C0416M4	2113945C31	R0303M7	0613952Q94
C0417M4	2113945A10	R0304M7	0613952Q89
C0418M4	2113945A10	R0305M7	0613952Q32
C0419M4	21667009315	R0306M7	0613952Q49
C0420M4	2113945A10	R0307M7	0613952H46
C0421M4	21667009291	R0308M7	0613952Q49
C0422M4	21667009385	R0309M7	0613952Q42
C0423M4	21667009282	R0310M7	0613952Q39
C0424M4	21667009291	R0311M7	0613952R66
C0425M4	21667009385	R0312M7	NOT PLACED
C0426M4	2113946F05	R0313M7	0613952Q73
C0427M4	2113945A05	R0314M7	0613952Q73
C0428M4	21667009282	R0400M4	0613952R01
C0429M4	21667009282	R0401M4	0613952H73
C0430M4	2113945A10	R0402M4	0613952R25
C0431M4	NOT PLACED	R0403M4	0613952R01
C0433M4	2113945A10	R0404M4	0613952R25
C0434M4	2113945A05	R0405M4	0613952R05
C0435M4	21667009388	R0406M4	0613952Q91
C0436M4	2113945C31	R0407M4	0613952Q91
C0437M4	2113945A10	R0408M4	0613952Q88
C0438M4	2113945A10	R0409M4	0613952R66
C0439M4	21667009365	R0410M4	0613952R01
C0440M4	21667009364	R0411M4	0613952R01
C0441M4	21667009373	R0412M4	0613952Q67
C0442M4	NOT PLACED	R0413M4	0613958H46
C0443M4	21667009373	R0414M4	0613958H49

Circuit Ref.	Motorola Solutions Part No.	Circuit Ref.	Motorola Solutions Part No.
C0444M4	21667009388	R0415M4	0613952Q49
C0445M4	21667009375	R0416M4	0613952Q69
C0446M4	21667009372	R0417M4	0613952Q75
C0447M4	21667009303	R0418M4	0613952Q69
C0448M4	21667009373	R0419M4	0613952Q69
C0449M4	21667009370	R0420M4	0613952R25
C0450M4	21667009386	R0421M4	0613952R25
C0451M4	2113945A10	R0422M4	0613952Q53
C0452M4	21667009378	R0423M4	0613952R25
C0453M4	21667009378	R0424M4	0613952Q39
C0454M4	21667009378	R0425M4	0613952Q53
C0455M4	21667009378	R0426M4	0613952Q87
C0456M4	2113945A10	R0427M4	0613952Q87
C0457M4	21667009201	R0429M4	0613952R66
C0458M4	2113946F05	R0430M4	NOT PLACED
C0459M4	NOT PLACED	R0431M4	0613952R01
C0461M4	2113945A10	R0432M4	0613952H73
C0462M4	2113945A10	R0433M4	0613952R01
C0463M4	2113945A10	R0434M4	0613952L46
C0464M4	NOT PLACED	R0435M4	0613952L46
C0467M4	2113956B21	R0437M4	0613952Q80
C0469M4	2113956B21	R0438M4	0613952Q25
C0500M3	21667009371	R0439M4	0613952Q69
C0501M3	21667009355	R0440M4	0613958H41
C0502M3	2113945Y02	R0441M4	0613958H41
C0503M3	2113945Y02	R0442M4	0613952Q83
C0504M3	2113945Y02	R0443M4	0613952Q33
C0505M3	21667009370	R0444M4	0613952K25
C0506M3	21667009371	R0445M4	0613952Q75
C0507M3	21667009307	R0446M4	NOT PLACED
C0508M3	21667009332	R0447M4	0613952R66
C0509M3	21667009380	R0448M4	0613952Q25
C0510M3	21667009307	R0465M4	0613952R66
C0511M3	NOT PLACED	R0500M3	0613952R08
C0512M3	21667009390	R0501M3	0613952R03

Circuit Ref.	Motorola Solutions Part No.	Circuit Ref.	Motorola Solutions Part No.
C0513M3	21667009378	R0502M3	0613952Q81
C0700M6	2113944C85	R0503M3	0613952Q87
C0701M6	21667009174	R0504M3	0613952Q61
C0702M6	2113944C83	R0505M3	NOT PLACED
C0703M6	2113944C51	R0700M6	0613952J01
C0704M6	NOT PLACED	R0701M6	0613952G67
C0705M6	NOT PLACED	R0702M6	0613952H49
C0706M6	NOT PLACED	R0703M6	0613952J01
C0707M6	2113945C31	R0704M6	0613952J01
C0708M6	2113944C82	R0705M6	0613952H47
C0709M6	2113945C04	R0706M6	0613952H48
C0710M6	21667009174	R0707M6	0613952H47
C0712M6	2113945L49	R0708M6	NOT PLACED
C0713M6	21667009174	R0709M6	NOT PLACED
C0714M6	NOT PLACED	R0710M6	NOT PLACED
C0715M6	NOT PLACED	R0711M6	0613958S49
C0716M6	2113944C51	R0712M6	0613958S49
C0718M6	NOT PLACED	R0713M6	NOT PLACED
C0719M6	NOT PLACED	R0714M6	0613952H35
C0720M6	2113944C51	R0715M6	0613952H35
C0721M6	2113945L37	R0716M6	0613952H35
C0723M6	2171741Y01	R0717M6	0613952H35
C0724M6	2113944C46	R0718M6	0613952H96
C0725M6	2113944C51	R0719M6	0613952H89
C0726M6	2113944C51	R0720M6	0613952J01
C0727M6	NOT PLACED	R0721M6	0613952G67
C0728M6	2111078B39	R0722M6	0613952H25
C0729M6	2113944C51	R0723M6	0613952G67
C0730M6	2113945L49	R0724M6	0613959Q53
C0731M6	21667009174	R0725M6	0613958S29
C0732M6	2113945A09	R0726M6	0613958S29
C0733M6	2113944C45	R0727M6	0613958S29
C0734M6	2113944C51	R0728M6	0613958S29
C0735M6	2113944C33	R0729M6	0613958S29
C0736M6	2111078B18	R0730M6	0613958S29

Circuit Ref.	Motorola Solutions Part No.	Circuit Ref.	Motorola Solutions Part No.
C0737M6	2113944C04	R0731M6	0613958S29
C0738M6	2113944C46	R0732M6	0613958S29
C0739M6	NOT PLACED	R0733M6	0613958S29
C0740M6	2113945C25	R0734M6	0613958S29
C0741M6	21667007049	R0735M6	0613958S29
C0742M6	2113944C30	R0736M6	0613959Q25
C0743M6	2113944F67	R0737M6	0613952F01
C0744M6	2113944F02	R0738M6	0613958S29
C0745M6	21009337414	R0739M6	0613952H73
C0746M6	NOT PLACED	R0740M6	0613952H73
C0747M6	NOT PLACED	R0741M6	0613952E66
C0748M6	2113945C31	R0742M6	0613952H73
C0749M6	NOT PLACED	R0743M6	0613952E66
C0750M6	NOT PLACED	R0744M6	NOT PLACED
C0751M6	NOT PLACED	R0745M6	0613952R66
C0752M6	2111078B59	R0746M6	0613952F01
C0753M6	2113944C51	R0747M6	NOT PLACED
C0754M6	2113944C45	R0748M6	0613958J49
C0755M6	2113944C36	R0749M6	0613958J49
C0756M6	2111078B39	R0750M6	0613958J49
C0757M6	2111078B39	R0751M6	0613958J49
C0758M6	2111078B42	R0752M6	0613958J49
C0759M6	2111078B42	R0753M6	0613958J49
C0760M6	2113944C79	R0754M6	0613958J49
C0761M6	2113944C45	R0755M6	0613959H12
C0762M6	2111078B34	R0756M6	0613959H12
C0763M6	NOT PLACED	R0757M6	0613952N43
C0764M6	2113944C51	R0758M6	0613958J49
C0766M6	2111078B34	R0759M6	0613959H12
C0768M6	2111078B38	R0760M6	0613958J49
C0769M6	NOT PLACED	R0761M6	0613958J49
C0770M6	2111078B18	R0762M6	0613958J49
C0771M6	NOT PLACED	R0763M6	0613952P01
C0772M6	NOT PLACED	R0876M6	0613958S73
C0773M6	2111078B39	R0877M6	0613959Y37

Circuit Ref.	Motorola Solutions Part No.	Circuit Ref.	Motorola Solutions Part No.
C0774M6	2111078B36	R0878M6	0613959Y37
C0775M6	2113944C06	R0879M6	0613952J25
C0776M6	2113944C31	R0882M6	0613952G67
C0777M6	NOT PLACED	R0883M6	0613952G67
C0778M6	21667011432	R0902M6	0613952R66
C0779M6	2113944C31	R0903M6	0613952N01
C0780M6	NOT PLACED	R0904M6	0613952R66
C0781M6	NOT PLACED	R0905M6	0613952H42
C0782M6	NOT PLACED	R0906M6	0613958H46
C0783M6	NOT PLACED	R0907M6	0613958H55
C0784M6	2113944C85	R0908M6	NOT PLACED
C0793M6	21667007048	R0909M6	NOT PLACED
C0794M6	2113944F07	R0910M6	NOT PLACED
C0796M6	21667007035	R0911M6	NOT PLACED
C0797M6	21667007035	R0912M6	0613958H46
C0798M6	21667007035	R0913M6	0613952M51
C0799M6	21667007035	R0914M6	0613952M71
C0801M6	NOT PLACED	R0915M6	0613952Z76
C0802M6	NOT PLACED	R0916M6	0613952R66
C0803M6	NOT PLACED	R0917M6	0613952P01
C0804M6	NOT PLACED	R0919M6	0613952P01
C0812M6	NOT PLACED	R0920M6	0613952N01
C0814M6	NOT PLACED	R0921M6	0613952N01
C0818M6	NOT PLACED	R0922M6	0613952R66
C0824M6	2111078B11	R0923M6	0613952M43
C0850M6	2111078B25	R0924M6	0613952N01
C0851M6	2111078B44	R0925M6	NOT PLACED
C0852M6	2111078B11	R0926M6	NOT PLACED
C0853M6	2111078B34	R0927M6	NOT PLACED
C0854M6	2111078B34	R0928M6	0613952P30
C0855M6	2111078B11	R0929M6	0613952N81
C0856M6	2111078B49	R0930M6	0613952N51
C0875M6	2113944C47	R0931M6	0613952Z26
C0876M6	2113944C32	R0932M6	0613952Z60
C0877M6	2113944C06	R0933M6	0613952Z50

Circuit Ref.	Motorola Solutions Part No.	Circuit Ref.	Motorola Solutions Part No.
C0879M6	2113944C06	R0934M6	0613952J17
C0880M6	2113944C35	R0935M6	0613952H91
C0881M6	2111078B27	R0936M6	NOT PLACED
C0882M6	2111078B57	R0937M6	NOT PLACED
C0883M6	NOT PLACED	R0938M6	NOT PLACED
C0884M6	2113944F15	R0950M6	0613952G67
C0885M6	2113944C51	R0951M6	0613958H55
C0899M6	2111078B04	R0952M6	0613958H53
C0900M6	NOT PLACED	R0953M6	0613952G67
C0901M6	NOT PLACED	R0954M6	0613952H39
C0902M6	2113944C51	R0955M6	0613952H39
C0905M6	2113945C31	R0956M6	0613952G67
C0906M6	2113945A10	R0957M6	0613958H55
C0907M6	2113945L41	R0958M6	0613958H53
C0908M6	21667009174	R0959M6	0613952R66
C0909M6	NOT PLACED	R0960M6	0613952N58
C0910M6	NOT PLACED	R0961M6	0613952N58
C0911M6	2113944C02	R0962M6	0613952N58
C0912M6	NOT PLACED	R0965M6	NOT PLACED
C0913M6	21667009174	R3000M6	0613952H60
C0914M6	21667009174	R3001M6	0615871H01
C0915M6	2113946B04	R3002M6	0615871H01
C0916M6	NOT PLACED	R3003M6	0615871H01
C0917M6	21667009174	R3004M6	0615871H01
C0918M6	21667009174	R3005M6	0613952H25
C0919M6	21667009174	R3006M6	0613952H25
C0920M6	NOT PLACED	R3007M6	0613952M30
C0921M6	2113944C51	R3008M6	0613952G67
C0922M6	NOT PLACED	R3009M6	0613952M43
C0923M6	NOT PLACED	R3010M6	0613952G67
C0924M6	NOT PLACED	R3011M6	0613959Q60
C0925M6	2113946B04	R3012M6	0613959Q60
C0926M6	2113944C02	R3013M6	0613952R01
C0950M6	2113944C51	R3014M6	0613952R01
C0951M6	2113944C30	R3015M6	0615871H01

Circuit Ref.	Motorola Solutions Part No.	Circuit Ref.	Motorola Solutions Part No.
C0952M6	2113944C51	R3018M6	0613952H73
C0953M6	2113944C51	R3019M6	0613952H60
C0954M6	2113944C81	R3020M6	0613952G67
C0955M6	2113944C51	R3021M6	0613952R25
C0956M6	2113944C01	RT0900M6	0615585H01
C0957M6	2113944C49	SH0000M2	26012095001
C3000M6	2113944C38	SH0001M2	26012095001
C3001M6	2113944C06	SH0002M2	26012097001
C3002M6	2113944C06	SH0003M2	26012094001
C3003M6	2113945C31	SH0004M2	26012094001
C3004M6	2113945C02	SH0200M7	26012095001
C3005M6	2113945C02	SH0300M7	26012231001
C3008M6	2113944C51	SH0400M4	26012096001
C3009M6	2113945C31	SH0401M4	26012096001
C3010M6	2113944C46	SH0402M4	26012098001
C3011M6	2113945G53	SH0403M4	26012098001
C3012M6	2113946J04	SH0500M3	26012098001
C3013M6	2113945C31	SH0700M6	26012100001
C3014M6	21009337414	SH0900M6	2686425Z02
C3015M6	2113946G01	SH0901M6	2686425Z02
C3016M6	2113945C31	SP3000M6	NOT PLACED
C3019M6	2113946S35	SP3001M6	NOT PLACED
C3020M6	2113945C26	T0000M2	25012016001
C3021M6	2113944C06	U0000M2	51009877001
C3022M6	2113945A10	U0001M2	5109731C48
C3029M6	NOT PLACED	U0002M2	4802197J95
C3038M6	21667009169	U0300M7	5186310Y39
C3041M6	21667009169	U0400M4	HZ000490A01
C3042M6	21667009169	U0500M3	4802197J95
C3044M6	21667009169	U0700M6	NOT PLACED
C3046M6	21667009174	U0901M6	5180390L83
C3047M6	21667009174	U0902M6	51012221001
C3048M6	21667009174	U0903M6	5115022H01
C3049M6	21667009174	U0904M6	5109731C48
D0000M2	4815011H01	U3000M6	5116525H01

Circuit Ref.	Motorola Solutions Part No.	Circuit Ref.	Motorola Solutions Part No.
D0001M2	4815011H01	U3001M6	4813973M07
D0400M4	4884800Y03	U3002M6	51012133001
D0401M4	4813974A19	VR0001M2	4815096H01
D0402M4	4813974A19	VR0200M7	48012260001
D0403M4	4884800Y03	VR0201M7	CR000291A01
D0500M3	4813974A19	VR0202M7	4815002H03
D0700M6	NOT PLACED	VR0203M7	CR000291A01
D0701M6	48012160001	VR0205M7	CR000291A01
D0875M6	48012160001	VR0206M7	48012260001
D0876M6	4886622Y06	VR0207M7	CR000291A01
D0900M6	NOT PLACED	VR0208M7	4815002H03
D0950M6	4813974A21	VR0209M7	CR000291A01
D0951M6	4813974A21	VR0400M4	CR000291A01
D3000M6	4813978P07	VR0401M4	CR000291A01
E0000M2	24012107027	VR0402M4	CR000291A01
E0001M2	24012107027	VR0403M4	CR000291A01
E0002M2	NOT PLACED	VR0404M4	CR000291A01
E0003M2	24012107027	VR0405M4	CR000291A01
E0004M2	24012107027	VR0406M4	CR000291A01
E0005M2	24012107027	VR0407M4	CR000291A01
E0006M2	24012107027	VR3000M6	48012202001
E0007M2	24012107027	VR3002M6	4813977M10
E0008M2	24012107027	Y0000M2	4875185M05

8.5

UHF1 Low Power Service Information

8.5.1

Allocation of Schematics and Circuit Boards

This chapter shows the schematics for the UHF1 circuits. The PCB component layouts and the Parts List in this chapter show both the Controller and UHF1 circuit components.

Diagrams and Parts List for 84012735001-A

Diagrams:

- [Figure 176: Main Board Top Side PCB No. 84012735001-A on page 330](#)
- [Figure 177: Main Board Bottom Side PCB No. 84012735001-A on page 331](#)
- [Figure 178: Overall Schematic Diagram on page 332](#)

- [Figure 179: Receiver Front-End Schematic Diagram on page 333](#)
- [Figure 180: Receiver IF Amp Schematic Diagram on page 334](#)
- [Figure 181: Transmitter Power Amplifier Schematic Diagram on page 335](#)
- [Figure 182: Power Control Schematic Diagram on page 336](#)
- [Figure 183: Transmitter Power Amplifier DC Distribution Schematic Diagram on page 337](#)
- [Figure 184: RFIC Schematic Diagram on page 338](#)
- [Figure 185: Receiver VCO Schematic Diagram on page 339](#)
- [Figure 186: Transmit VCO Schematic Diagram on page 340](#)
- [Figure 187: VCO Buffer Schematic Diagram on page 341](#)

[Parts List for 84012735001-A on page 342](#)

Diagrams and Parts List for 84012735003-C

Diagrams:

- [Figure 188: Main Board Top Side PCB No. 84012735003-C on page 367](#)
- [Figure 189: Main Board Bottom Side PCB No. 84012735003-C on page 368](#)
- [Figure 190: Overall Schematic Diagram on page 369](#)
- [Figure 191: Receiver Front-End Schematic Diagram on page 370](#)
- [Figure 192: Receiver IF Amp Schematic Diagram on page 371](#)
- [Figure 193: Transmitter Power Amplifier Schematic Diagram on page 372](#)
- [Figure 194: Power Control Schematic Diagram on page 373](#)
- [Figure 195: Transmitter Power Amplifier DC Distribution Schematic Diagram on page 374](#)
- [Figure 196: RFIC Schematic Diagram on page 375](#)
- [Figure 197: Receiver VCO Schematic Diagram on page 376](#)
- [Figure 198: Transmit VCO Schematic Diagram on page 377](#)
- [Figure 199: VCO Buffer Schematic Diagram on page 378](#)

[Parts List for 84012735003-C on page 379](#)

8.5.1.1

Circuit Board and Schematic Diagrams for 84012735001-A

Figure 176: Main Board Top Side PCB No. 84012735001-A

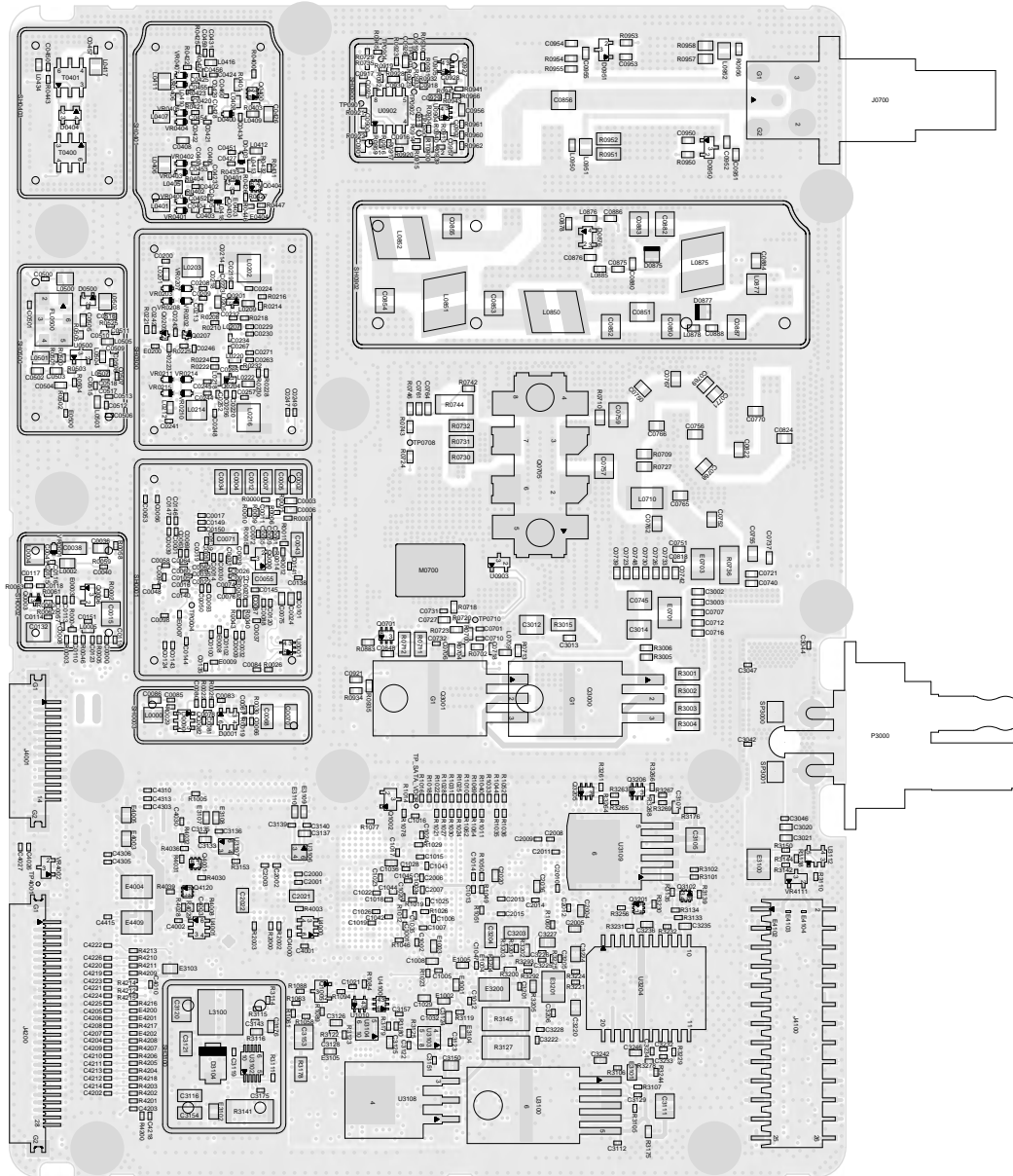

Figure 177: Main Board Bottom Side PCB No. 84012735001-A

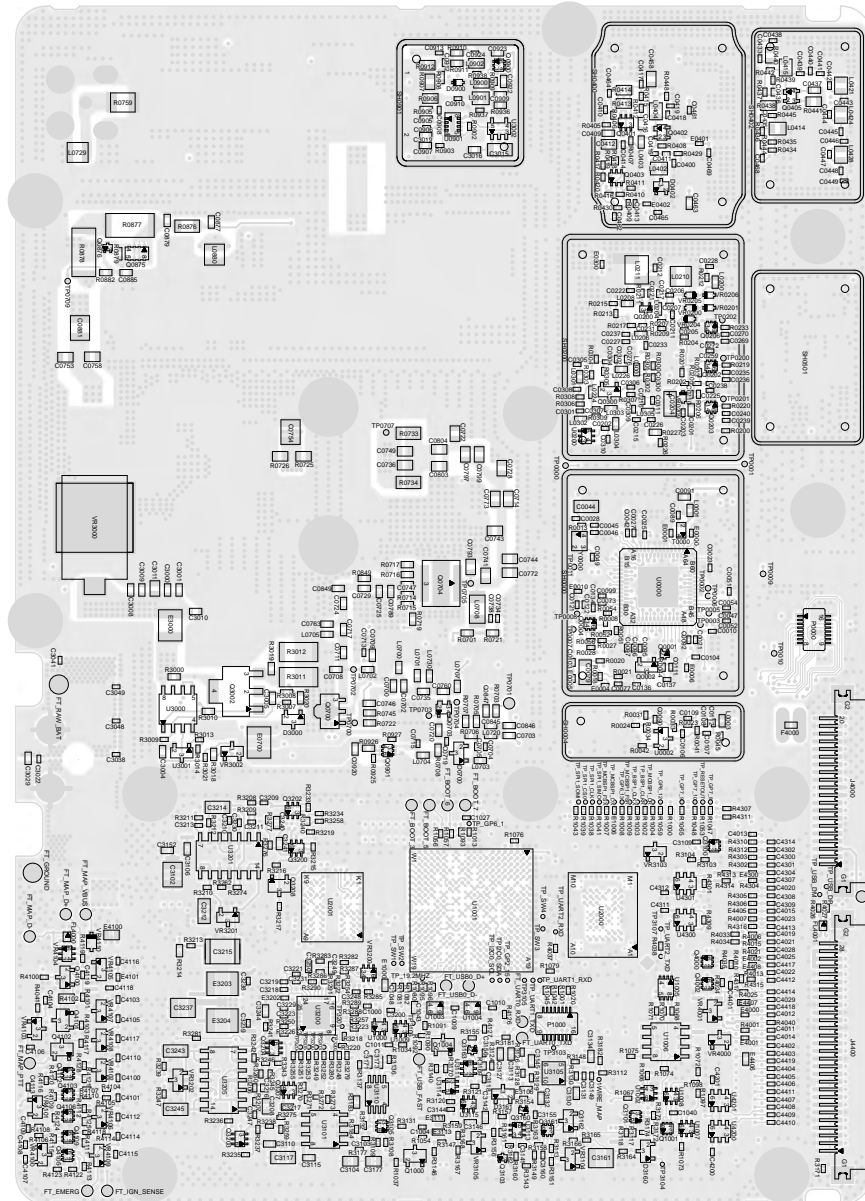

Figure 178: Overall Schematic Diagram

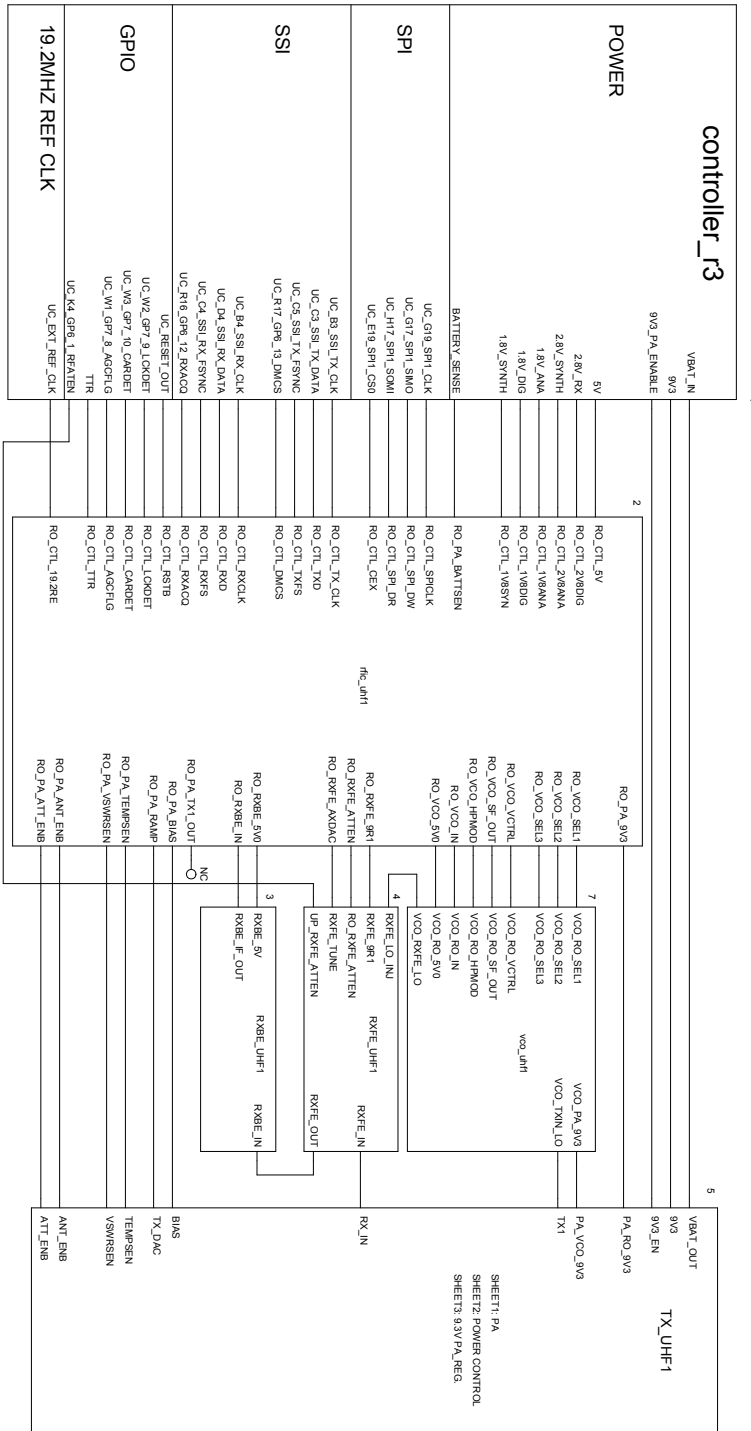

Figure 179: Receiver Front-End Schematic Diagram

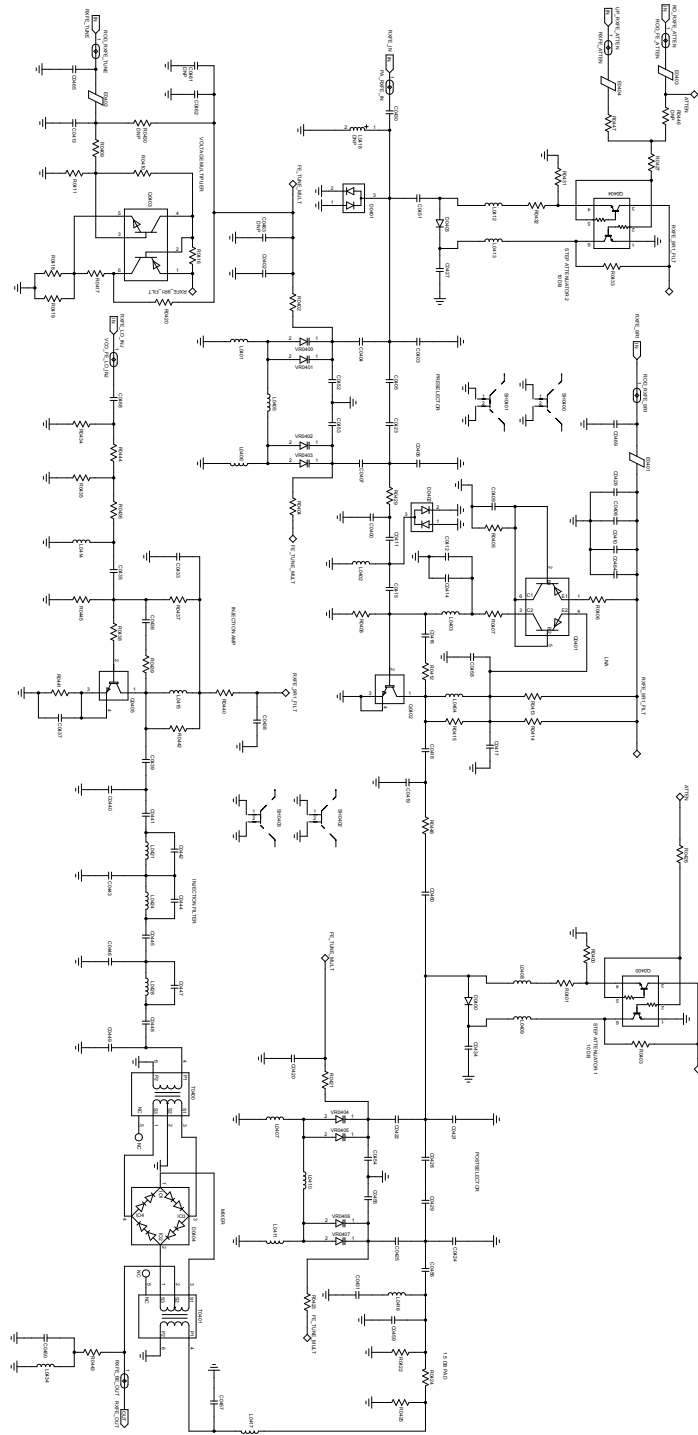

Figure 180: Receiver IF Amp Schematic Diagram

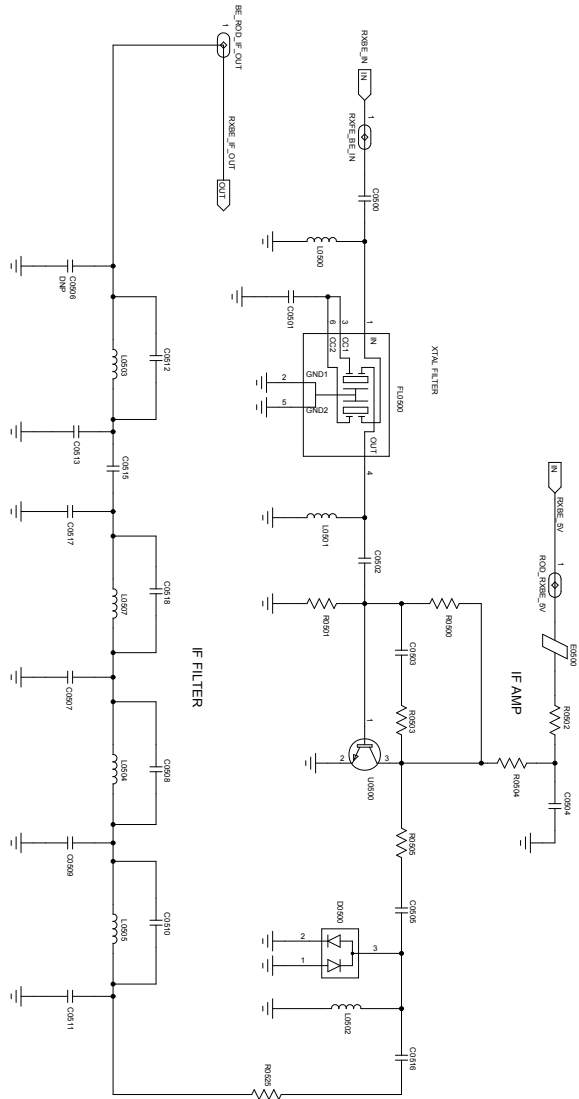
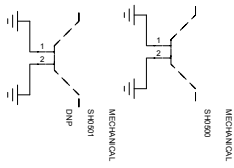

Figure 181: Transmitter Power Amplifier Schematic Diagram

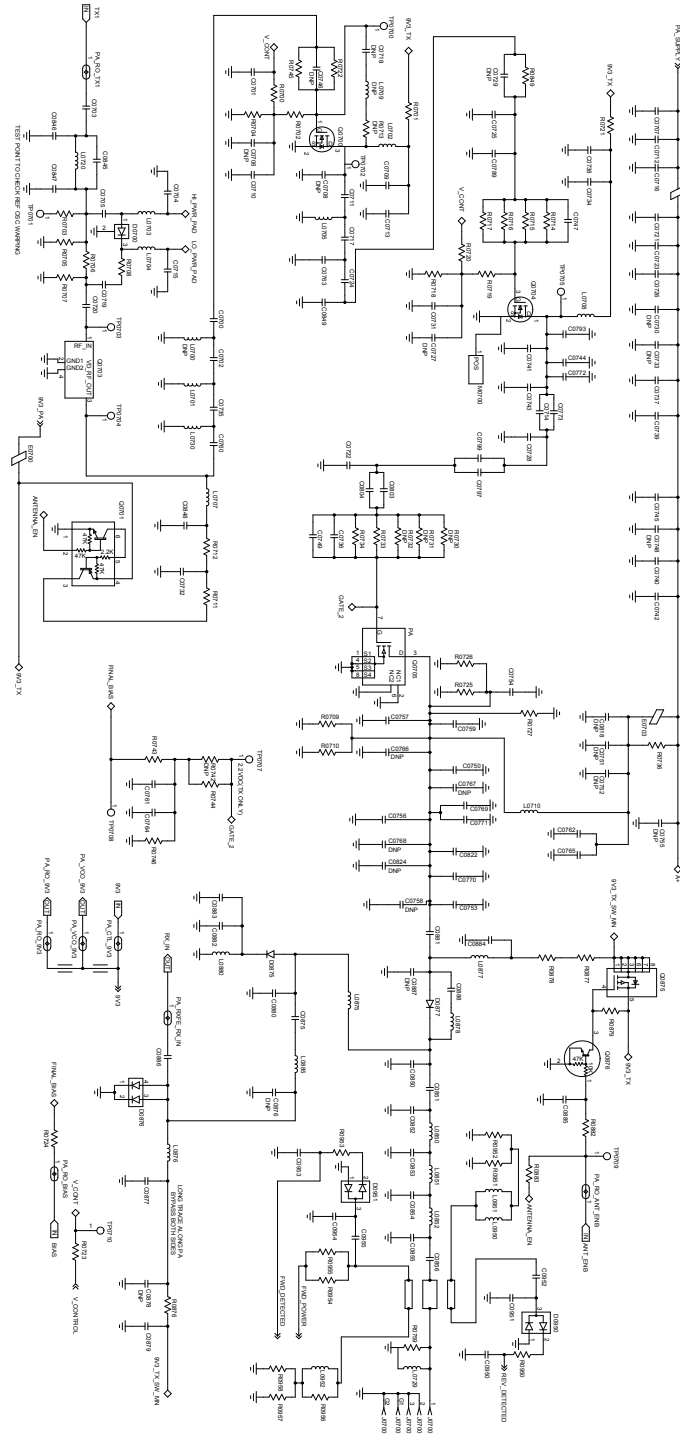

Figure 182: Power Control Schematic Diagram

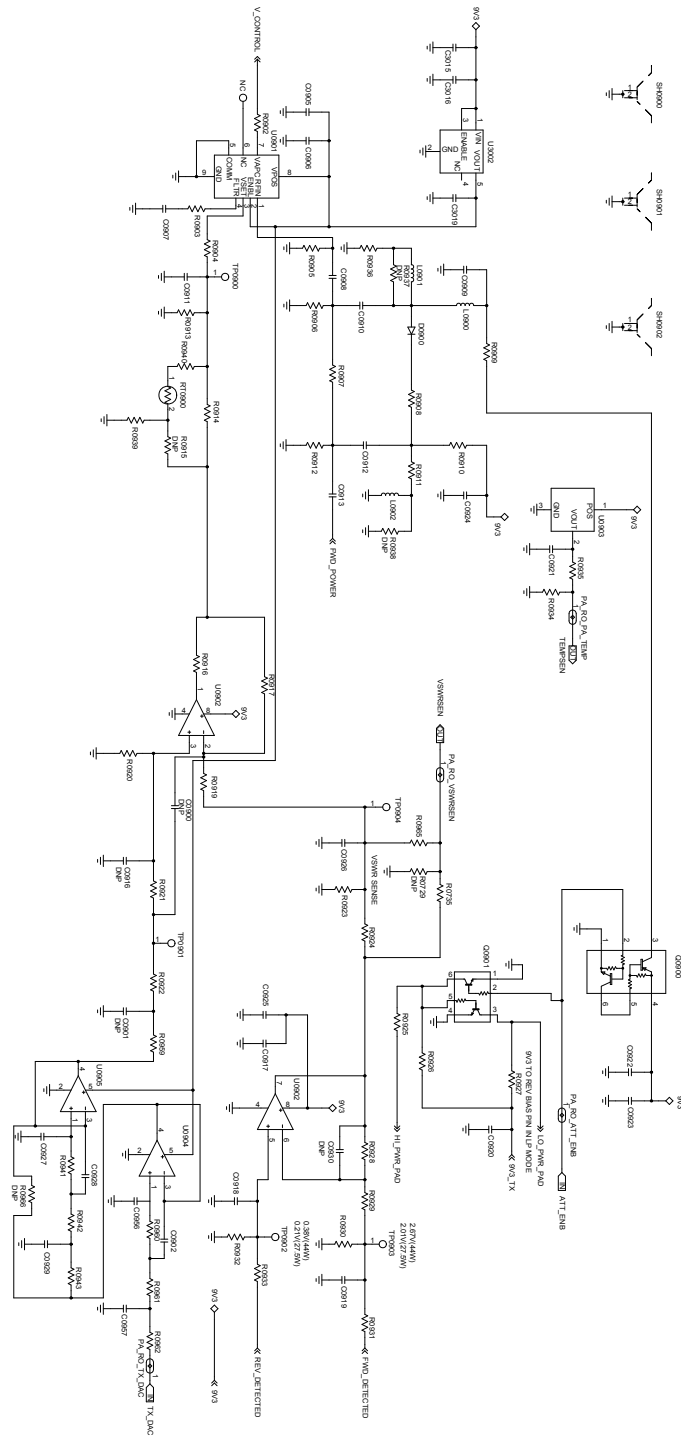

Figure 183: Transmitter Power Amplifier DC Distribution Schematic Diagram

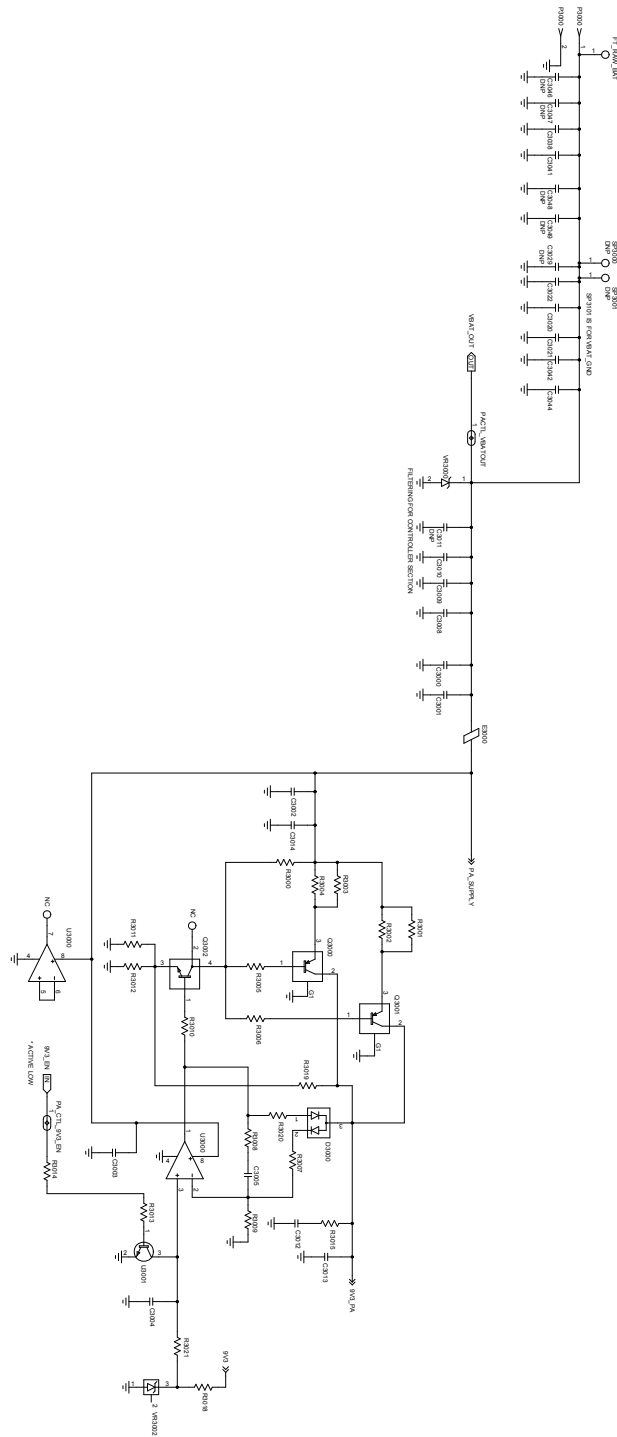

Figure 184: RFIC Schematic Diagram

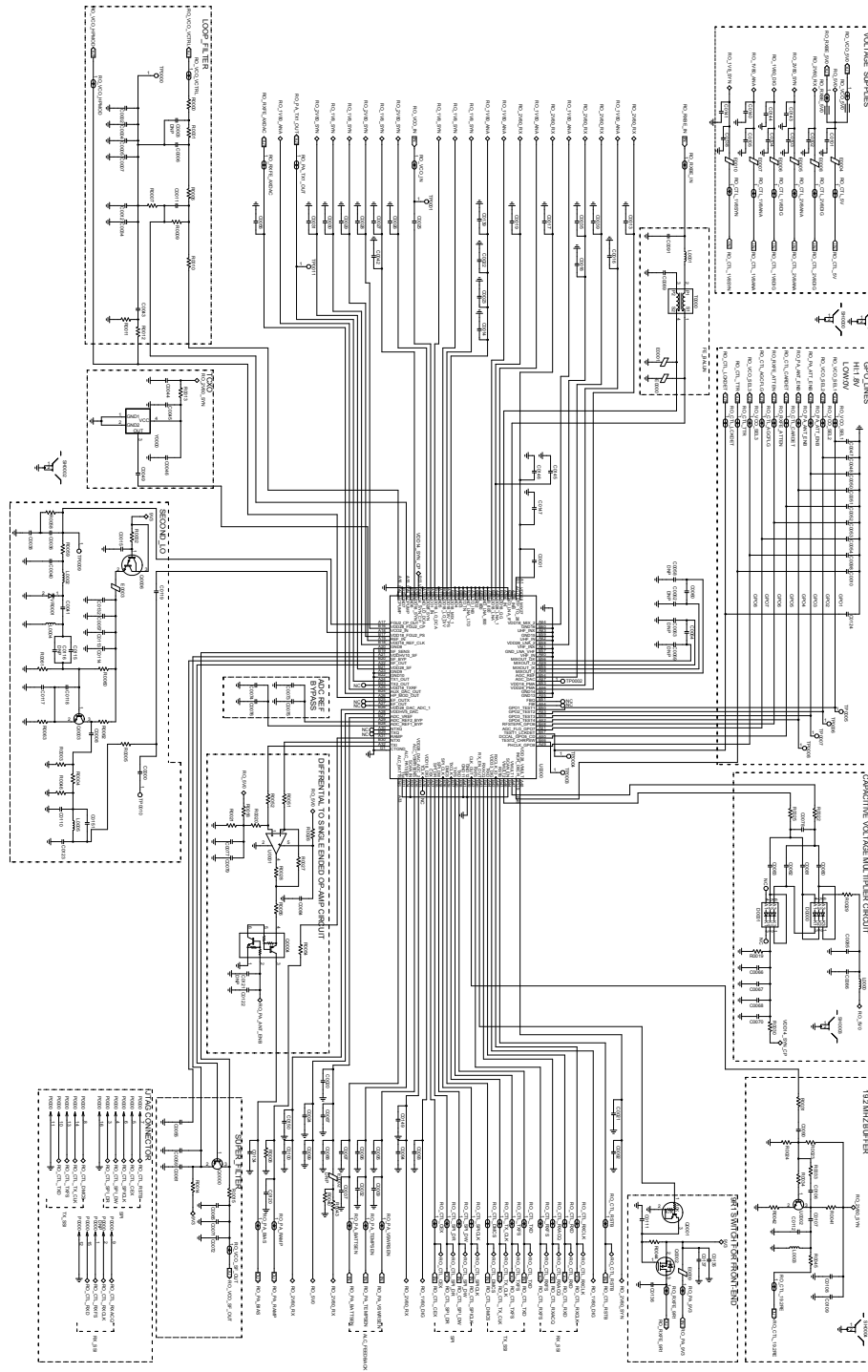

Figure 185: Receiver VCO Schematic Diagram

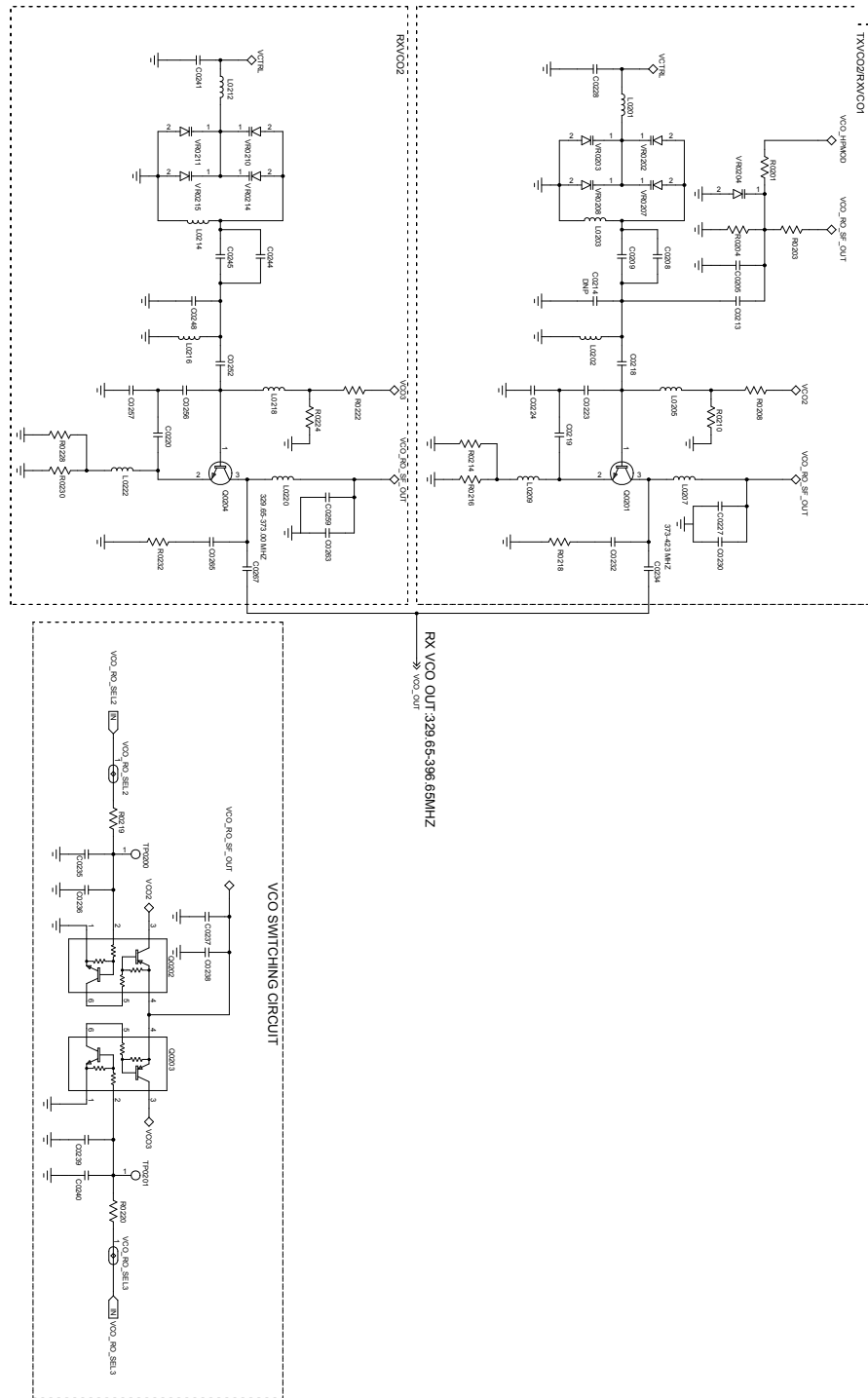

Figure 186: Transmit VCO Schematic Diagram

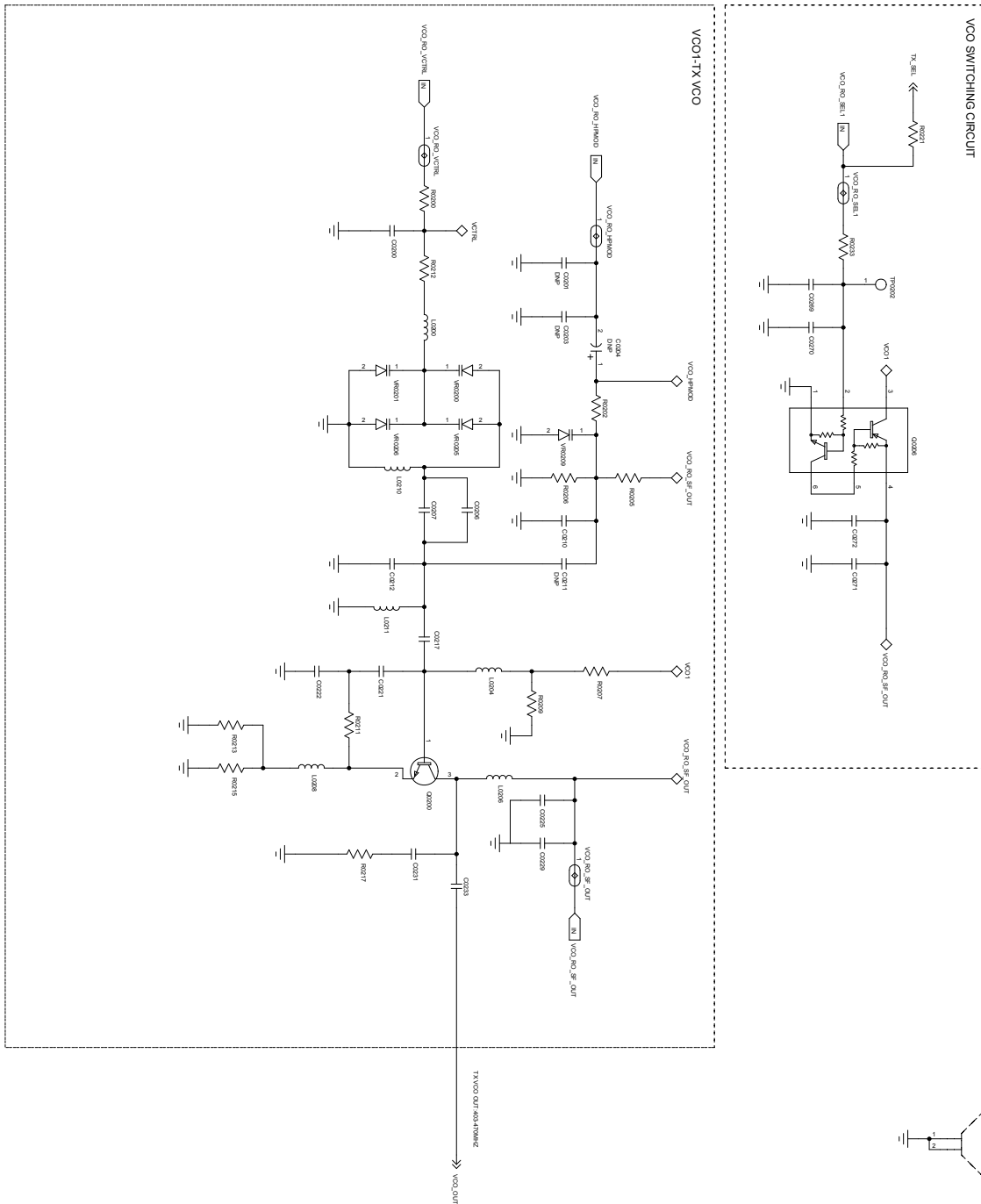
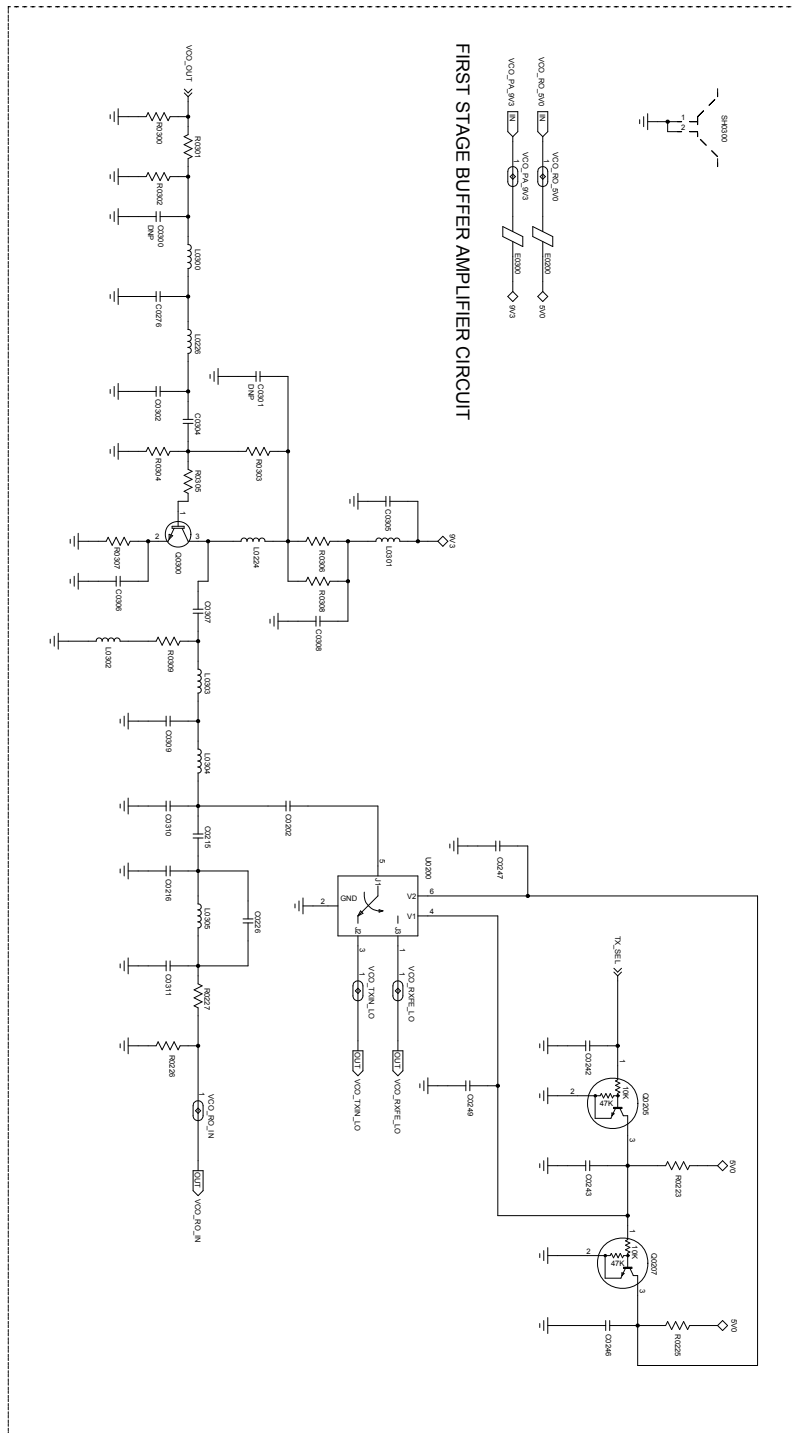

Figure 187: VCO Buffer Schematic Diagram



8.5.1.2

Parts List for 84012735001-A

Table 21: UHF1 Radio Parts List

Circuit Ref.	Motorola Solutions Part No.	Circuit Ref.	Motorola Solutions Part No.
C0000M2	21667009311	L0412M4	24667008030
C0001M2	21667009170	L0413M4	24667008030
C0002M2	21012044001	L0414M4	24009344106
C0003M2	NOT PLACED	L0415M4	24009344108
C0004M2	21012044001	L0416M4	24667008017
C0005M2	21012044001	L0417M4	24009344110
C0006M2	2113945C31	L0418M4	NOT PLACED
C0007M2	21012044001	L0421M4	24009344106
C0008M2	21667009311	L0424M4	24009344106
C0009M2	21667009166	L0428M4	24009344106
C0010M2	21667009166	L0434M4	24667008021
C0011M2	2113945C31	L0500M3	24009344127
C0012M2	21012044001	L0501M3	24009344128
C0013M2	2113945Y02	L0502M3	24009344126
C0014M2	2113945Y02	L0503M3	24667008021
C0015M2	2113946J03	L0504M3	24667008026
C0016M2	2113945A10	L0505M3	24667008026
C0017M2	2113945Y02	L0507M3	24667008024
C0018M2	2113945A10	L0700M5	NOT PLACED
C0019M2	2113945Y02	L0701M5	24667008007
C0020M2	2113945A10	L0702M5	24667008028
C0021M2	2113945Y02	L0703M5	24667008028
C0022M2	2113945Y02	L0704M5	24667008028
C0023M2	2113945Y02	L0705M5	24667008007
C0024M2	21012102001	L0707M5	24667008028
C0025M2	21667009166	L0708M5	2479990G01
C0026M2	21667009174	L0709M5	NOT PLACED
C0027M2	2113945Y02	L0710M5	2460591C53
C0028M2	2113945Y02	L0720M5	24667008014
C0029M2	2113945A10	L0729M5	2414032B60
C0030M2	2113945A10	L0730M5	24667008014
C0031M2	2113945Y02	L0850M5	2460592A01

Circuit Ref.	Motorola Solutions Part No.	Circuit Ref.	Motorola Solutions Part No.
C0032M2	21667009166	L0851M5	2460592A01
C0034M2	21012044001	L0852M5	2460592A01
C0035M2	21667009166	L0875M5	2460592A01
C0036M2	21012025001	L0876M5	24667008029
C0037M2	21667009166	L0877M5	2414032B49
C0038M2	21012044001	L0878M5	24667008024
C0039M2	2113945Y02	L0880M5	2414032B49
C0040M2	2113945A10	L0885M5	24667008014
C0041M2	21667009364	L0900M5	24667000031
C0042M2	21667009166	L0901M5	24009344018
C0043M2	21012044001	L0902M5	24667000031
C0044M2	2113955D45	L0950M5	24667008024
C0045M2	2113945Y02	L0951M5	24009344003
C0046M2	21667009166	L0952M5	24009344026
C0047M2	21667009166	L3100M1	24012091002
C0048M2	21667009166	M0700M5	2686201B02
C0049M2	2113945B02	P0000M2	NOT PLACED
C0050M2	21667009166	P1000M1	2887818K02
C0051M2	21667009166	P3000M5	09009344001
C0052M2	21667009166	Q0000M2	4813973A13
C0053M2	21667009166	Q0001M2	48009494001
C0054M2	21667009166	Q0002M2	4813970A59
C0055M2	2113955D37	Q0003M2	48012195001
C0056M2	2113945Y02	Q0004M2	4815272H01
C0057M2	2113945B02	Q0006M2	4813973A04
C0058M2	NOT PLACED	Q0200M7	48012195001
C0059M2	21667009166	Q0201M7	48012195001
C0060M2	2113945A69	Q0202M7	4815272H01
C0061M2	2113945Y02	Q0203M7	4815272H01
C0062M2	NOT PLACED	Q0204M7	48012195001
C0063M2	NOT PLACED	Q0205M7	48009494001
C0064M2	2113945A69	Q0206M7	4815272H01
C0065M2	2113945Y02	Q0207M7	48009494001
C0066M2	2113945B02	Q0300M7	4802197J95
C0067M2	2113945Y02	Q0400M4	4815271H01

Circuit Ref.	Motorola Solutions Part No.	Circuit Ref.	Motorola Solutions Part No.
C0068M2	2113955D37	Q0401M4	4815267H01
C0069M2	NOT PLACED	Q0402M4	4815118H01
C0070M2	2113955D37	Q0403M4	4815270H01
C0071M2	2113955D37	Q0404M4	4815271H01
C0072M2	21667009166	Q0405M4	4815118H01
C0073M2	21667009166	Q0700M5	4816547H01
C0074M2	21667009166	Q0701M5	4816013H01
C0075M2	2113946S35	Q0703M5	4802246J29
C0076M2	2113946S35	Q0704M5	4816548H01
C0077M2	21667009166	Q0705M5	48012067002
C0078M2	21667009372	Q0875M5	4813970A62
C0079M2	2113955D37	Q0876M5	48009494001
C0080M2	2113945B02	Q0900M5	4815272H01
C0081M2	2113945B02	Q0901M5	4815271H01
C0082M2	2113945B02	Q1000M1	4815263H01
C0083M2	2113945B02	Q1001M1	4815272H01
C0084M2	21667009166	Q1002M1	4815261H01
C0085M2	21667009166	Q1004M1	4815261H01
C0086M2	2113945C31	Q1005M1	4815261H01
C0087M2	2113946S35	Q3000M5	0105959T72
C0088M2	2113945Y02	Q3001M5	0105959T72
C0089M2	2113945Y02	Q3002M5	4813973B01
C0090M2	2113945B02	Q3100M1	4815272H01
C0091M2	2113944C82	Q3101M1	4809939C47
C0092M2	21667009166	Q3102M1	4809939C47
C0093M2	2113945Y02	Q3103M1	48009494001
C0094M2	2113945Y02	Q3105M1	4809939C47
C0095M2	2113945A13	Q3160M1	48009494001
C0096M2	2113945B02	Q3161M1	4815272H01
C0097M2	2113945B02	Q3162M1	4813973M07
C0098M2	21667009166	Q3163M1	48009494001
C0099M2	2113945Y02	Q3200M1	4815270H01
C0100M2	2113945Y02	Q3201M1	4815272H01
C0101M2	21667009166	Q3202M1	4815270H01
C0102M2	21667009166	Q3203M1	4815270H01

Circuit Ref.	Motorola Solutions Part No.	Circuit Ref.	Motorola Solutions Part No.
C0103M2	21667009166	Q3204M1	4815270H01
C0104M2	21667009166	Q3205M1	4815270H01
C0105M2	21667009166	Q3206M1	4815270H01
C0106M2	2113945B02	Q3207M1	4815270H01
C0107M2	2113945B02	Q3208M1	4815263H01
C0108M2	21667009166	Q4000M1	4809939C47
C0109M2	2113945Y02	Q4001M1	4809939C47
C0110M2	21667009381	Q4002M1	4809939C47
C0111M2	2113945Y02	Q4100M1	4816023H01
C0112M2	21667009166	Q4101M1	4815261H01
C0113M2	21667009166	Q4102M1	4815263H01
C0114M2	2113945Y02	Q4103M1	48012271001
C0115M2	21667009370	Q4105M1	48012271001
C0116M2	NOT PLACED	Q4106M1	48012271001
C0117M2	21667009374	Q4109M1	48012271001
C0118M2	21667009375	Q4112M1	48012271001
C0119M2	2113945A10	Q4120M1	4809939C47
C0120M2	21667009166	R0000M2	0613952R66
C0121M2	NOT PLACED	R0001M2	0613952R66
C0122M2	21667009166	R0002M2	0613952Q96
C0123M2	21667009381	R0003M2	0613952Q57
C0124M2	21667009166	R0004M2	0613952Q34
C0132M2	2113946J03	R0005M2	0613952R66
C0134M2	21667009166	R0006M2	0613952Q25
C0135M2	21667009166	R0007M2	0613952Q51
C0136M2	21667009166	R0008M2	0613952R01
C0137M2	2113945Y02	R0009M2	0613952Q58
C0138M2	21667009166	R0010M2	0613952R66
C0139M2	21667009166	R0011M2	0613952Q36
C0140M2	2113945Y02	R0012M2	0613952Q86
C0141M2	2113945Y02	R0013M2	0613952Q35
C0143M2	2113945Y02	R0014M2	0613952R66
C0144M2	2113945Y02	R0015M2	0613952R66
C0145M2	21667009166	R0018M2	0613952Q80
C0146M2	2113945A10	R0019M2	0613952R01

Circuit Ref.	Motorola Solutions Part No.	Circuit Ref.	Motorola Solutions Part No.
C0147M2	2113945A10	R0020M2	0613952R12
C0149M2	21667009166	R0021M2	0613952Q80
C0150M2	21667009166	R0022M2	0613952R66
C0151M2	21667009368	R0023M2	0613952Q83
C0200M7	21667009166	R0024M2	0613952Q80
C0201M7	NOT PLACED	R0025M2	0613952R66
C0202M7	21667009166	R0026M2	0613952R66
C0203M7	NOT PLACED	R0027M2	0613952R12
C0204M7	NOT PLACED	R0028M2	0613952R66
C0205M7	21667009274	R0029M2	0613952Q25
C0206M7	21667009366	R0030M2	0613952R66
C0207M7	21667009365	R0031M2	0613952R66
C0208M7	21667009311	R0033M2	0613952R01
C0209M7	21667009311	R0034M2	0613952Q57
C0210M7	21667009274	R0040M2	0613952Q70
C0211M7	NOT PLACED	R0041M2	0613952Q58
C0212M7	21667009294	R0042M2	0613952Q42
C0213M7	21667009274	R0043M2	0613952Q73
C0214M7	NOT PLACED	R0044M2	0613952R25
C0215M7	21667009315	R0045M2	0613952R66
C0216M7	21667009311	R0046M2	0613952Q57
C0217M7	21667009346	R0051M2	0613952R01
C0218M7	21667009339	R0052M2	0613952R01
C0219M7	21667009378	R0054M2	0613952M25
C0220M7	21667009380	R0056M2	0613952R66
C0221M7	21667009371	R0058M2	0613952Q74
C0222M7	21667009366	R0059M2	0613952R66
C0223M7	21667009370	R0060M2	0613952Q89
C0224M7	21667009369	R0061M2	0613952Q85
C0225M7	2113945Y02	R0062M2	0613952Q61
C0226M7	21667009311	R0063M2	0613952Q64
C0227M7	2113945Y02	R0200M7	0613952R66
C0228M7	21667009166	R0201M7	0613952R27
C0229M7	21667009166	R0202M7	0613952R27
C0230M7	21667009166	R0203M7	0613952R07

Circuit Ref.	Motorola Solutions Part No.	Circuit Ref.	Motorola Solutions Part No.
C0231M7	21667009166	R0204M7	0613952R05
C0232M7	21667009166	R0205M7	0613952R07
C0233M7	21667009284	R0206M7	0613952R05
C0234M7	21667009315	R0207M7	0613952Q84
C0235M7	21667009166	R0208M7	0613952Q87
C0236M7	2113945Y02	R0209M7	0613952Q85
C0237M7	21667009166	R0210M7	0613952Q79
C0238M7	2113945Y02	R0211M7	0613952Q18
C0239M7	2113945Y02	R0212M7	0613952Q32
C0240M7	21667009166	R0213M7	0613952Q67
C0241M7	21667009166	R0214M7	0613952Q67
C0242M7	21667009166	R0215M7	0613952Q67
C0243M7	21667009166	R0216M7	0613952Q67
C0244M7	21667009332	R0217M7	0613952Q49
C0245M7	21667009332	R0218M7	0613952Q49
C0246M7	21667009166	R0219M7	0613952R66
C0247M7	21667009166	R0220M7	0613952R66
C0248M7	21667009326	R0221M7	0613952R66
C0249M7	21667009166	R0222M7	0613952Q79
C0252M7	21667009326	R0223M7	0613952Q73
C0256M7	21667009371	R0224M7	0613952Q78
C0257M7	21667009366	R0225M7	0613952Q73
C0259M7	2113945Y02	R0226M7	0613952Q29
C0263M7	21667009166	R0227M7	0613952G67
C0265M7	21667009166	R0228M7	0613952Q67
C0267M7	21667009297	R0230M7	0613952Q67
C0269M7	21667009166	R0232M7	0613952Q49
C0270M7	2113945Y02	R0233M7	0613952R66
C0271M7	21667009166	R0300M7	0613952Q66
C0272M7	2113945Y02	R0301M7	0613952Q25
C0276M7	21667009311	R0302M7	0613952Q66
C0300M7	NOT PLACED	R0303M7	0613952R05
C0301M7	NOT PLACED	R0304M7	0613952Q89
C0302M7	21667009286	R0305M7	0613952Q33
C0304M7	21667009390	R0306M7	0613952Q32

Circuit Ref.	Motorola Solutions Part No.	Circuit Ref.	Motorola Solutions Part No.
C0305M7	2113945Y02	R0307M7	0613952Q49
C0306M7	2113945B02	R0308M7	0613952Q32
C0307M7	21667009390	R0309M7	0613952Q42
C0308M7	2113945B02	R0400M4	0613952R01
C0309M7	21667009280	R0401M4	0613952H81
C0310M7	21667009279	R0402M4	0613952R25
C0311M7	21667009346	R0403M4	0613952R01
C0400M4	21667009274	R0404M4	0613952R25
C0402M4	21667009166	R0405M4	0613952R05
C0403M4	21667009297	R0406M4	0613952Q91
C0404M4	21667009368	R0407M4	0613952Q91
C0405M4	21667009284	R0408M4	0613952Q75
C0406M4	21667009297	R0409M4	0613952Q69
C0407M4	21667009368	R0410M4	0613952R01
C0408M4	2113945C31	R0411M4	0613952R01
C0409M4	2113945C31	R0412M4	0613952Q83
C0410M4	21667009166	R0413M4	0613958H55
C0411M4	21667009376	R0414M4	0613958H55
C0412M4	2113946F05	R0415M4	0613952Q57
C0413M4	21667009166	R0416M4	0613952Q69
C0414M4	21667009166	R0417M4	0613952Q69
C0415M4	21667009370	R0418M4	0613952Q69
C0416M4	2113945C31	R0419M4	0613952Q69
C0417M4	21667009166	R0420M4	0613952R25
C0418M4	21667009166	R0421M4	0613952R25
C0419M4	21667009274	R0422M4	0613952Q67
C0420M4	21667009166	R0423M4	0613952R25
C0421M4	21667009297	R0424M4	0613952Q23
C0422M4	21667009368	R0425M4	0613952Q67
C0423M4	21667009280	R0426M4	0613952Q87
C0424M4	21667009297	R0427M4	0613952Q93
C0425M4	21667009368	R0429M4	0613952R66
C0426M4	2113946F05	R0430M4	NOT PLACED
C0427M4	21667009372	R0431M4	0613952R01
C0428M4	21667009284	R0432M4	0613952H73

Circuit Ref.	Motorola Solutions Part No.	Circuit Ref.	Motorola Solutions Part No.
C0429M4	21667009280	R0433M4	0613952R01
C0430M4	21667009161	R0434M4	0613952L46
C0431M4	21667009368	R0435M4	0613952L46
C0433M4	21667009166	R0436M4	0613952R66
C0434M4	21667009384	R0437M4	0613952Q77
C0435M4	21667009380	R0438M4	0613958H25
C0436M4	21667009166	R0439M4	0613952Q83
C0437M4	2113945C31	R0440M4	0613958H25
C0438M4	21667009166	R0441M4	0613958H49
C0439M4	21667009346	R0442M4	0613952Q83
C0440M4	21667009315	R0443M4	0613952Q25
C0441M4	21667009372	R0444M4	0613952K25
C0442M4	21667009277	R0445M4	0613952Q75
C0443M4	21667009364	R0446M4	NOT PLACED
C0444M4	21667009286	R0447M4	0613952R66
C0445M4	21667009368	R0448M4	0613952Q25
C0446M4	21667009355	R0500M3	0613952Q87
C0447M4	21667009277	R0501M3	0613952R19
C0448M4	21667009372	R0502M3	0613952Q66
C0449M4	21667009315	R0503M3	0613952Q88
C0450M4	21667009388	R0504M3	0613952Q61
C0451M4	21667009166	R0505M3	0613952R66
C0452M4	21667009366	R0525M3	0613952R66
C0453M4	21667009366	R0700M5	0613952J05
C0454M4	21667009366	R0701M5	0613952G67
C0455M4	21667009366	R0702M5	0613952H89
C0456M4	21667009355	R0703M5	0613952J01
C0457M4	21667009307	R0704M5	0613952J06
C0458M4	2113946F05	R0705M5	0613952H47
C0459M4	21667009307	R0706M5	0613952H54
C0460M4	21667009166	R0707M5	0613952H47
C0461M4	NOT PLACED	R0708M5	0613952H45
C0462M4	21667009159	R0709M5	0613958J49
C0463M4	NOT PLACED	R0710M5	0613958J49
C0464M4	21667009158	R0711M5	0613958S44

Circuit Ref.	Motorola Solutions Part No.	Circuit Ref.	Motorola Solutions Part No.
C0465M4	21667009166	R0712M5	0613958S44
C0468M4	21667009166	R0713M5	NOT PLACED
C0469M4	21667009166	R0714M5	0613952H09
C0500M3	21667009369	R0715M5	0613952H09
C0501M3	21667009332	R0716M5	0613952H09
C0502M3	2113944M21	R0717M5	0613952H09
C0503M3	2113945C31	R0718M5	0613952H94
C0504M3	2113945C31	R0719M5	0613952H89
C0505M3	21667011351	R0720M5	0613952H95
C0506M3	NOT PLACED	R0721M5	0613952G67
C0507M3	21667009374	R0722M5	0613952H25
C0508M3	21667009366	R0723M5	0613952G67
C0509M3	21667009382	R0724M5	0613952G67
C0510M3	21667009366	R0725M5	0613958J49
C0511M3	21667009355	R0726M5	0613958J49
C0512M3	21667009303	R0727M5	0613958J49
C0513M3	21667009368	R0729M5	0613952N43
C0515M3	21667009383	R0730M5	NOT PLACED
C0516M3	21667011464	R0731M5	NOT PLACED
C0517M3	21667009315	R0732M5	NOT PLACED
C0518M3	21667009339	R0733M5	0613958S29
C0700M5	2113944C46	R0734M5	0613958S29
C0701M5	21667009163	R0735M5	0613952P01
C0702M5	2113944C38	R0736M5	0613959Q25
C0703M5	2113944C42	R0742M5	NOT PLACED
C0704M5	21667009163	R0743M5	0613952J17
C0705M5	21667009163	R0744M5	0613959Q42
C0706M5	NOT PLACED	R0745M5	0613952H25
C0707M5	2113944C82	R0746M5	0613952J25
C0708M5	NOT PLACED	R0759M5	0613959H12
C0709M5	2113945C04	R0849M5	0613952G67
C0710M5	21667009163	R0876M5	0613958S73
C0711M5	2113944C46	R0877M5	0613959Y37
C0712M5	2113945C04	R0878M5	0613959Y37
C0713M5	21667009163	R0879M5	0613952J25

Circuit Ref.	Motorola Solutions Part No.	Circuit Ref.	Motorola Solutions Part No.
C0714M5	2113944F47	R0882M5	0613952G67
C0715M5	21667009163	R0883M5	0613952G67
C0716M5	2113944C55	R0902M5	0613952R66
C0717M5	2113944C82	R0903M5	0613952N01
C0718M5	NOT PLACED	R0904M5	0613952R66
C0719M5	21667009163	R0905M5	0613952H42
C0720M5	2113944C42	R0906M5	0613958H46
C0721M5	2113944C82	R0907M5	0613958H55
C0722M5	2113944F44	R0908M5	0613952H42
C0723M5	2113945C04	R0909M5	0613952R66
C0724M5	2113944C83	R0910M5	0613952H91
C0725M5	2113944C38	R0911M5	0613952H85
C0726M5	2113944C51	R0912M5	0613958H46
C0727M5	NOT PLACED	R0913M5	0613952M51
C0728M5	2113944F39	R0914M5	0613952M71
C0729M5	NOT PLACED	R0915M5	NOT PLACED
C0730M5	NOT PLACED	R0916M5	0613952R66
C0731M5	21667009163	R0917M5	0613952P01
C0732M5	2113945A09	R0919M5	0613952P01
C0733M5	NOT PLACED	R0920M5	0613952N01
C0734M5	2113945A09	R0921M5	0613952N01
C0735M5	2113944C30	R0922M5	0613952R66
C0736M5	2113944F64	R0923M5	0613952M42
C0737M5	2113944C51	R0924M5	0613952N01
C0738M5	21667009163	R0925M5	0613952Q59
C0739M5	2113945C31	R0926M5	0613952H79
C0740M5	2113944C51	R0927M5	0613952N01
C0741M5	2113944F53	R0928M5	0613952N81
C0742M5	2113945L49	R0929M5	0613952N85
C0743M5	2113944F56	R0930M5	0613952N42
C0744M5	2113944F52	R0931M5	0613952M66
C0745M5	21009337414	R0932M5	0613952N30
C0746M5	NOT PLACED	R0933M5	0613952N01
C0747M5	2113944C44	R0934M5	0613952J17
C0748M5	NOT PLACED	R0935M5	0613952H91

Circuit Ref.	Motorola Solutions Part No.	Circuit Ref.	Motorola Solutions Part No.
C0749M5	2113944F64	R0936M5	0613952H91
C0750M5	2111078A25	R0937M5	NOT PLACED
C0751M5	NOT PLACED	R0938M5	NOT PLACED
C0752M5	NOT PLACED	R0939M5	0613952R66
C0753M5	2111078A21	R0940M5	0613952Z76
C0754M5	2111078B33	R0941M5	0613952N58
C0755M5	NOT PLACED	R0942M5	0613952N58
C0756M5	2111078A25	R0943M5	0613952N58
C0757M5	2111078B32	R0950M5	0613952G67
C0758M5	NOT PLACED	R0951M5	0613958M18
C0759M5	2111078B31	R0952M5	0613958M18
C0760M5	2113944C80	R0953M5	0613952G67
C0761M5	2113944C45	R0954M5	0613952H56
C0762M5	2113944F01	R0955M5	0613952H56
C0763M5	2113944C34	R0956M5	0613952H67
C0764M5	2113944C51	R0957M5	0613958C25
C0765M5	2113944F01	R0958M5	0613958C25
C0766M5	NOT PLACED	R0959M5	0613952R66
C0767M5	NOT PLACED	R0960M5	0613952N58
C0768M5	NOT PLACED	R0961M5	0613952N58
C0769M5	2111078A21	R0962M5	0613952N58
C0770M5	2111078A06	R0965M5	NOT PLACED
C0771M5	2111078A21	R0966M5	NOT PLACED
C0772M5	2113944F52	R1000M1	0613952R66
C0773M5	2113944F47	R1001M1	0613952M66
C0789M5	2113944C38	R1002M1	0613952R66
C0793M5	2113944F57	R1003M1	0613952R66
C0797M5	2113944F01	R1004M1	0613952R66
C0799M5	2113944F01	R1005M1	0613952M66
C0803M5	2113944F01	R1007M1	0613952R66
C0804M5	2113944F02	R1008M1	0613952R66
C0818M5	NOT PLACED	R1009M1	0613952R66
C0822M5	2111078A17	R1010M1	NOT PLACED
C0824M5	NOT PLACED	R1011M1	NOT PLACED
C0845M5	21667011411	R1012M1	0613952R66

Circuit Ref.	Motorola Solutions Part No.	Circuit Ref.	Motorola Solutions Part No.
C0846M5	21667011059	R1013M1	0613952M66
C0847M5	21667011059	R1014M1	NOT PLACED
C0848M5	2113944C45	R1016M1	NOT PLACED
C0849M5	2113944C35	R1018M1	NOT PLACED
C0850M5	2111078B05	R1019M1	0613952R66
C0851M5	2111078B21	R1020M1	0613952M66
C0852M5	2111078B08	R1021M1	0613952Q73
C0853M5	2111078B16	R1022M1	NOT PLACED
C0854M5	2111078B15	R1023M1	0613952R66
C0855M5	2111078B08	R1024M1	NOT PLACED
C0856M5	2111078B42	R1025M1	0613952Q73
C0875M5	2113944C42	R1026M1	0613952R66
C0876M5	NOT PLACED	R1027M1	NOT PLACED
C0877M5	2113944C42	R1028M1	0613952R66
C0878M5	NOT PLACED	R1029M1	0613952R66
C0879M5	2113944C42	R1030M1	NOT PLACED
C0880M5	21667011073	R1031M1	0613952R66
C0881M5	2111078B42	R1033M1	0613952Q73
C0882M5	2111078B22	R1034M1	0613952R17
C0883M5	2111078B34	R1035M1	NOT PLACED
C0884M5	2113944F05	R1036M1	0613952M66
C0885M5	2113944C51	R1037M1	0613952M66
C0886M5	2113944C47	R1038M1	0613952R66
C0887M5	NOT PLACED	R1039M1	0613952R66
C0888M5	2113944C42	R1040M1	0613952M66
C0900M5	NOT PLACED	R1041M1	0613952R66
C0901M5	NOT PLACED	R1042M1	0613952M66
C0902M5	2113944C51	R1043M1	0613952R66
C0905M5	2113945C31	R1044M1	0613952M66
C0906M5	2113945A10	R1045M1	0613952M66
C0907M5	2113945L41	R1046M1	0613952M66
C0908M5	21667009166	R1047M1	0613952R66
C0909M5	2113944C02	R1048M1	0613952R66
C0910M5	21667009166	R1049M1	0613952Q73
C0911M5	2113944C02	R1050M1	0613952Q73

Circuit Ref.	Motorola Solutions Part No.	Circuit Ref.	Motorola Solutions Part No.
C0912M5	21667009166	R1051M1	0613952K68
C0913M5	21667009166	R1052M1	NOT PLACED
C0916M5	NOT PLACED	R1053M1	0613952R66
C0917M5	21667009166	R1054M1	0613952M66
C0918M5	21667009166	R1056M1	0613952Q73
C0919M5	21667009166	R1057M1	0613952Q73
C0920M5	2113944C02	R1058M1	0613952M66
C0921M5	2113944C02	R1059M1	0613952R66
C0922M5	2113945C31	R1060M1	0613952R66
C0923M5	2113944C02	R1061M1	0613952R66
C0924M5	21667009166	R1062M1	NOT PLACED
C0925M5	2113945C31	R1063M1	NOT PLACED
C0926M5	2113944C02	R1064M1	NOT PLACED
C0927M5	2113944C01	R1065M1	0613952R66
C0928M5	2113944C51	R1066M1	0613952M66
C0929M5	2113944C49	R1067M1	0613952M66
C0930M5	NOT PLACED	R1068M1	0613952R32
C0950M5	2113944C47	R1069M1	NOT PLACED
C0951M5	21667011356	R1070M1	0613952Q77
C0952M5	2113944C47	R1071M1	0613952Q77
C0953M5	2113944C47	R1072M1	0613952Q49
C0954M5	21667011457	R1073M1	0613952R01
C0955M5	2113944C47	R1074M1	0613952R66
C0956M5	2113944C01	R1075M1	0613952R66
C0957M5	2113944C49	R1076M1	0613952R66
C1000M1	2113945Y02	R1077M1	0613952R66
C1001M1	2113945Y02	R1078M1	0613952R66
C1002M1	2113946K03	R1079M1	0613952R66
C1003M1	2113945Y02	R1080M1	0613952Q32
C1004M1	2113945Y02	R1081M1	0613952Q32
C1005M1	2113945Y02	R1082M1	0613952Q32
C1006M1	2113945Y02	R1084M1	0613952R66
C1007M1	2113945Y02	R1088M1	NOT PLACED
C1008M1	2113946D05	R1089M1	0613952R05
C1009M1	2113945Y02	R1090M1	0613952R05

Circuit Ref.	Motorola Solutions Part No.	Circuit Ref.	Motorola Solutions Part No.
C1010M1	2113945Y02	R1091M1	NOT PLACED
C1011M1	2113945B02	R1092M1	0613952M43
C1012M1	2113945Y02	R1093M1	0613952Q73
C1013M1	2113945Y02	R1094M1	0613952M66
C1014M1	2113945Y02	R1095M1	0613952Q34
C1015M1	2113945B02	R1096M1	0613952Q34
C1016M1	21667009166	R1097M1	0613952R66
C1017M1	21667009162	R1098M1	0613952R66
C1018M1	21667009162	R2000M1	0613952M66
C1019M1	21667009162	R2002M1	0613952M66
C1020M1	21667009162	R2003M1	0613952M30
C1021M1	2113945Y02	R3000M5	0613952H60
C1022M1	2113945Y02	R3001M5	0615871H01
C1023M1	2113945Y02	R3002M5	0615871H01
C1024M1	2113945Y02	R3003M5	0615871H01
C1025M1	2113945Y02	R3004M5	0615871H01
C1026M1	2113945Y02	R3005M5	0613952H25
C1027M1	NOT PLACED	R3006M5	0613952H25
C1028M1	2113945Y02	R3007M5	0613952M30
C1029M1	2113956B54	R3008M5	0613952G67
C1032M1	2113956B54	R3009M5	0613952M43
C1035M1	2113945B02	R3010M5	0613952G67
C1036M1	2113946D05	R3011M5	0613959Q60
C1040M1	2113945Y02	R3012M5	0613959Q60
C1041M1	2113945B02	R3013M5	0613952R01
C1042M1	2113945Y02	R3014M5	0613952R01
C1043M1	2113956B54	R3015M5	0615871H01
C1044M1	2113945B02	R3018M5	0613952H73
C1045M1	2113945B02	R3019M5	0613952H60
C1047M1	2113945Y02	R3020M5	0613952G67
C1048M1	2113945B02	R3021M5	0613952R25
C2000M1	2113945Y02	R3101M1	0613952Z66
C2001M1	2113945Y02	R3102M1	0613952M66
C2002M1	2113945B02	R3103M1	0613952N62
C2003M1	21667009162	R3104M1	0613952M30

Circuit Ref.	Motorola Solutions Part No.	Circuit Ref.	Motorola Solutions Part No.
C2004M1	2113956B54	R3105M1	0613952R01
C2005M1	2113946D05	R3106M1	0613952M09
C2006M1	2113945Y02	R3107M1	0613952M85
C2007M1	2113945Y02	R3108M1	0613952R17
C2008M1	2113945B02	R3109M1	0613952R17
C2009M1	21667009162	R3110M1	0613952N55
C2010M1	2113945Y02	R3111M1	0613952R32
C2011M1	2113945Y02	R3112M1	0613952P12
C2012M1	2113945Y02	R3113M1	0613952R17
C2013M1	2113945Y02	R3114M1	0613952N01
C2014M1	2113945B02	R3115M1	0613952Z63
C2015M1	21667009162	R3116M1	0613952E83
C2016M1	2113956B54	R3117M1	0613952Q73
C2020M1	2113956B54	R3118M1	0613952R10
C2021M1	2113956D59	R3119M1	0613952Q73
C2022M1	2113956D59	R3120M1	0613952R66
C3000M5	2113944C38	R3121M1	0613952R66
C3001M5	2113944C06	R3122M1	0613952M43
C3002M5	2113944C06	R3123M1	0613952M54
C3003M5	2113945C31	R3124M1	0613952R66
C3004M5	2113945C02	R3125M1	0613952R66
C3005M5	2113945C02	R3126M1	0613952R66
C3008M5	2113944C51	R3127M1	0613959Y09
C3009M5	2113945C31	R3128M1	0613952M10
C3010M5	2113944C46	R3129M1	0613952M58
C3011M5	NOT PLACED	R3130M1	0613952R25
C3012M5	2113946J04	R3131M1	0613952R01
C3013M5	2113945C31	R3132M1	0613952R01
C3014M5	21009337414	R3133M1	0613952R29
C3015M5	2113946G01	R3134M1	NOT PLACED
C3016M5	2113945C31	R3135M1	0613952R66
C3019M5	2113946S35	R3136M1	0613952R17
C3020M5	2113945C26	R3137M1	0613952R17
C3021M5	2113944C06	R3138M1	0613952R17
C3022M5	2113945A10	R3139M1	0613952R66

Circuit Ref.	Motorola Solutions Part No.	Circuit Ref.	Motorola Solutions Part No.
C3029M5	NOT PLACED	R3140M1	0613952Q91
C3038M5	21667009379	R3141M1	0613959Y13
C3041M5	21667009379	R3142M1	NOT PLACED
C3042M5	21667009379	R3143M1	0613952Q91
C3044M5	21667009379	R3144M1	0613952R66
C3046M5	NOT PLACED	R3145M1	0613959Y09
C3047M5	NOT PLACED	R3146M1	0613952M85
C3048M5	NOT PLACED	R3147M1	0613952M43
C3049M5	NOT PLACED	R3148M1	0613952R66
C3102M1	21009337414	R3149M1	0613952R01
C3103M1	21667009166	R3150M1	0613952N62
C3104M1	2113946F08	R3151M1	0613952R25
C3105M1	2113946J04	R3153M1	0613952R66
C3106M1	2113945C31	R3154M1	0613952Q89
C3107M1	2113944C38	R3155M1	0613952Q89
C3109M1	21667009166	R3156M1	0613952R17
C3110M1	2113944C06	R3157M1	0613952R01
C3111M1	2113946J04	R3158M1	0613952R66
C3112M1	2113945Y02	R3159M1	0613952R01
C3113M1	2113946S35	R3160M1	0613952Q89
C3115M1	2113944C06	R3161M1	0613952Q73
C3116M1	2113955D13	R3162M1	0613952Q85
C3117M1	2113955D13	R3163M1	0613952R01
C3118M1	2113945Y02	R3164M1	0613952Q75
C3119M1	2113945Y02	R3165M1	0613952R01
C3120M1	2113956E60	R3166M1	0613952R17
C3121M1	2113956D58	R3167M1	0613952R01
C3122M1	2113956A51	R3168M1	0613952Q73
C3123M1	2113956A51	R3169M1	0613952R01
C3124M1	2113946D07	R3170M1	0613952R01
C3125M1	2113946D05	R3171M1	NOT PLACED
C3126M1	2113944C06	R3172M1	NOT PLACED
C3127M1	2113946S35	R3173M1	0613952R66
C3128M1	2113946D05	R3174M1	0613952R66
C3129M1	2113945Y02	R3175M1	0689774Y02

Circuit Ref.	Motorola Solutions Part No.	Circuit Ref.	Motorola Solutions Part No.
C3130M1	2113946D05	R3176M1	0689774Y02
C3131M1	2113946A02	R3177M1	0613952R66
C3132M1	2113946D05	R3178M1	0615871H01
C3133M1	2113946D05	R3179M1	0613952R17
C3134M1	2113946S35	R3180M1	0613952R01
C3135M1	2113956A51	R3181M1	NOT PLACED
C3136M1	21012095001	R3182M1	0613952R66
C3137M1	2113946D05	R3183M1	0613952H92
C3139M1	2113956A51	R3184M1	0613952M30
C3140M1	21012095001	R3200M1	0613952C44
C3141M1	2113945Y02	R3201M1	0613952Q49
C3142M1	21012102001	R3202M1	0613952C44
C3143M1	21667009366	R3203M1	0613952Q49
C3144M1	2113945Y02	R3204M1	0613952C44
C3145M1	2113944C06	R3205M1	0613952C44
C3146M1	21012102001	R3206M1	0613952R01
C3149M1	2113956A51	R3207M1	0613952R01
C3150M1	2113956C37	R3208M1	0613952N30
C3151M1	2113945B02	R3209M1	0613952R03
C3152M1	2113944C06	R3210M1	0613952Q67
C3153M1	2113946J04	R3211M1	0613952N30
C3154M1	2113955D13	R3212M1	0613952R03
C3155M1	2113945Y02	R3213M1	0613952Q42
C3156M1	2113945Y02	R3214M1	0613952J25
C3157M1	2113945Y02	R3215M1	0613952R01
C3160M1	2113945Y02	R3216M1	0613952R17
C3161M1	NOT PLACED	R3217M1	0613952R01
C3171M1	2113946D07	R3218M1	0613952R01
C3173M1	2113946D07	R3219M1	NOT PLACED
C3175M1	2113946A01	R3220M1	0613952R01
C3176M1	2113944C48	R3221M1	NOT PLACED
C3177M1	2113946F08	R3222M1	0613952R01
C3200M1	21667009166	R3223M1	0613952R66
C3201M1	21667009166	R3224M1	NOT PLACED
C3203M1	2113955D37	R3225M1	NOT PLACED

Circuit Ref.	Motorola Solutions Part No.	Circuit Ref.	Motorola Solutions Part No.
C3204M1	2113955D37	R3226M1	0613952R01
C3205M1	21667009166	R3229M1	0613952R01
C3206M1	21667009166	R3230M1	0613952R10
C3208M1	2113956C37	R3231M1	0613952R10
C3209M1	2113945Y02	R3232M1	0613952R10
C3210M1	2113945Y02	R3233M1	0613952R01
C3211M1	2113945A11	R3234M1	NOT PLACED
C3212M1	2113955D37	R3235M1	0613952R01
C3213M1	2113945A03	R3236M1	0613952R10
C3214M1	2113955D37	R3237M1	NOT PLACED
C3215M1	2113956F49	R3238M1	0613952R01
C3216M1	2113945Y02	R3239M1	0613952Q49
C3217M1	2113956B91	R3240M1	0613952R01
C3218M1	2113956A51	R3241M1	0613952M54
C3219M1	2113956A51	R3242M1	0613952R01
C3220M1	2113946F05	R3243M1	0613952R01
C3221M1	2113945Y02	R3244M1	0613952R10
C3222M1	2113956A51	R3245M1	NOT PLACED
C3223M1	2113945Y02	R3246M1	0613952R01
C3224M1	2113946F05	R3247M1	0613952Q49
C3225M1	2113945Y02	R3248M1	0613952R66
C3226M1	NOT PLACED	R3249M1	0613952R66
C3227M1	2113946F05	R3250M1	0613952R66
C3228M1	2113945Y02	R3251M1	0613952R66
C3229M1	2113956A51	R3252M1	0613952R66
C3230M1	2113945Y02	R3253M1	0613952R66
C3231M1	2113945Y02	R3254M1	0613952R01
C3232M1	2113945Y02	R3255M1	0613952R66
C3233M1	2113945A09	R3256M1	0613952M66
C3234M1	2113945Y02	R3257M1	0613952R01
C3235M1	21012102001	R3258M1	0613952M66
C3236M1	2113945C31	R3259M1	0613952M66
C3237M1	21009337414	R3260M1	0613952M66
C3238M1	2113945A09	R3261M1	0613952R01
C3239M1	2113945A09	R3262M1	0613952R10

Circuit Ref.	Motorola Solutions Part No.	Circuit Ref.	Motorola Solutions Part No.
C3240M1	2113956B91	R3263M1	NOT PLACED
C3241M1	2113956B91	R3264M1	0613952R01
C3242M1	2113945C31	R3265M1	0613952M66
C3243M1	2113955D37	R3266M1	0613952R01
C3244M1	2113956B91	R3267M1	NOT PLACED
C3245M1	2113955D37	R3268M1	0613952R01
C3246M1	2113945C31	R3269M1	0613952M66
C3247M1	2113945Y02	R3270M1	0613952R01
C3248M1	2113945Y02	R3271M1	NOT PLACED
C3249M1	2113956B91	R3272M1	0613952R01
C3250M1	2113956B91	R3273M1	0613952M66
C4000M1	2113945Y02	R3274M1	0613952R10
C4001M1	2113945Y02	R3275M1	0613952R10
C4002M1	2113945Y02	R3276M1	0613952R10
C4003M1	2113945Y02	R3277M1	0613952R10
C4010M1	21667009166	R3278M1	0613952R01
C4011M1	21667009166	R3279M1	NOT PLACED
C4012M1	21667009166	R3280M1	NOT PLACED
C4013M1	21667009166	R3281M1	NOT PLACED
C4014M1	21667009166	R3282M1	0613952R66
C4015M1	21667009166	R3283M1	0613952R66
C4019M1	21667009166	R3285M1	0613952R01
C4020M1	21667009166	R3286M1	0613952R66
C4021M1	21667009166	R3287M1	0613952R66
C4022M1	21667009166	R3288M1	0613952R01
C4023M1	21667009166	R3289M1	0613952R01
C4025M1	21667009166	R3290M1	NOT PLACED
C4026M1	21667009166	R3291M1	NOT PLACED
C4027M1	21667009166	R3292M1	0613952R66
C4028M1	21667009166	R3293M1	0613952R66
C4029M1	21667009166	R4001M1	0613952R66
C4030M1	21667009166	R4003M1	0613952R66
C4100M1	21667009166	R4006M1	0613952Q37
C4101M1	21667009166	R4007M1	0613952Q37
C4103M1	21667009166	R4008M1	0613952R01

Circuit Ref.	Motorola Solutions Part No.	Circuit Ref.	Motorola Solutions Part No.
C4104M1	21667009166	R4010M1	0613952R01
C4105M1	21667009166	R4013M1	0613952Q42
C4106M1	21667009166	R4015M1	0613952Q37
C4107M1	21667009166	R4021M1	0613952R66
C4108M1	21667009166	R4024M1	0613952R01
C4109M1	21667009166	R4025M1	0613952R01
C4110M1	21667009166	R4026M1	0613952R66
C4112M1	21667009166	R4027M1	0613952R66
C4113M1	21667009166	R4028M1	0613952R01
C4114M1	21667009166	R4029M1	0613952R01
C4115M1	21667009166	R4030M1	0613952R01
C4116M1	21667009166	R4031M1	0613952R01
C4117M1	21667009166	R4032M1	0613952R66
C4118M1	21667009166	R4033M1	0613952M43
C4119M1	21667009166	R4034M1	0613952M43
C4200M1	2113945Y02	R4035M1	0613952R66
C4201M1	2113945Y02	R4036M1	0613952R66
C4202M1	21667009166	R4037M1	0613952R01
C4203M1	21667009166	R4038M1	0613952R01
C4204M1	NOT PLACED	R4039M1	NOT PLACED
C4205M1	21667009166	R4040M1	NOT PLACED
C4206M1	21667009166	R4041M1	NOT PLACED
C4207M1	21667009166	R4100M1	0613952R01
C4208M1	21667009166	R4101M1	0613952Q77
C4209M1	21667009166	R4102M1	0613958H83
C4210M1	21667009166	R4103M1	0613952Q85
C4211M1	21667009166	R4104M1	0613952Q89
C4212M1	21667009166	R4105M1	0613952Q89
C4213M1	21667009166	R4106M1	0613952Q89
C4214M1	21667009166	R4107M1	0613952R01
C4218M1	21667009166	R4108M1	0613952Q89
C4219M1	21667009339	R4109M1	0613952N58
C4220M1	21667009339	R4110M1	0613952Q85
C4221M1	21667009339	R4111M1	0613952Q85
C4222M1	21667009339	R4112M1	0613952R01

Circuit Ref.	Motorola Solutions Part No.	Circuit Ref.	Motorola Solutions Part No.
C4223M1	21667009339	R4113M1	0613952R01
C4224M1	21667009166	R4114M1	0613952Q89
C4225M1	21667009166	R4115M1	0613952N58
C4226M1	21667009339	R4116M1	0613952Q89
C4300M1	NOT PLACED	R4117M1	0613952R01
C4301M1	NOT PLACED	R4118M1	0613952R01
C4302M1	NOT PLACED	R4119M1	0613952R01
C4303M1	NOT PLACED	R4120M1	0613952N58
C4304M1	21667009166	R4121M1	0613952Q85
C4305M1	21667009376	R4122M1	0613952Q85
C4306M1	21667009381	R4123M1	0613952N58
C4307M1	NOT PLACED	R4124M1	0613952N58
C4308M1	NOT PLACED	R4125M1	0613952Q85
C4309M1	21667009166	R4126M1	0613952Q85
C4310M1	21667009166	R4127M1	0613952Q85
C4311M1	2113945Y02	R4128M1	0613952R01
C4312M1	2113945Y02	R4200M1	0613952R66
C4313M1	21667009166	R4201M1	0613952R66
C4314M1	NOT PLACED	R4202M1	0613952R66
C4401M1	NOT PLACED	R4203M1	0613952R66
C4402M1	NOT PLACED	R4204M1	0613952R66
C4403M1	NOT PLACED	R4205M1	0613952R66
C4404M1	NOT PLACED	R4206M1	0613952R66
C4405M1	NOT PLACED	R4207M1	0613952R66
C4406M1	NOT PLACED	R4208M1	0613952R66
C4407M1	NOT PLACED	R4209M1	HZ000375A01
C4408M1	NOT PLACED	R4210M1	HZ000375A01
C4409M1	NOT PLACED	R4211M1	HZ000375A01
C4410M1	NOT PLACED	R4212M1	HZ000375A01
C4411M1	NOT PLACED	R4213M1	HZ000375A01
C4412M1	21667009166	R4214M1	HZ000375A01
C4413M1	21667009166	R4215M1	0613952R66
C4414M1	21667009166	R4216M1	0613952R66
C4415M1	21667009166	R4217M1	0613952R66
C4417M1	21667009166	R4218M1	0613952R66

Circuit Ref.	Motorola Solutions Part No.	Circuit Ref.	Motorola Solutions Part No.
C4418M1	21667009166	R4301M1	NOT PLACED
C4419M1	21667009166	R4302M1	0613952R66
D0000M2	4815011H01	R4303M1	0613952R66
D0001M2	4815011H01	R4304M1	0613952R66
D0400M4	4884800Y03	R4305M1	0613952R66
D0401M4	4813974A19	R4306M1	0613952R66
D0402M4	4813974A19	R4307M1	0613952R66
D0403M4	4884800Y03	R4309M1	NOT PLACED
D0404M4	4815090H01	R4310M1	0613952R66
D0500M3	4813974A19	R4311M1	0613952R66
D0700M5	4813974A06	R4312M1	0613952R66
D0875M5	48012160001	R4313M1	NOT PLACED
D0876M5	4886622Y06	R4314M1	0613952R66
D0877M5	48012160001	R4315M1	0613952R66
D0900M5	48012181001	R4316M1	0613952R66
D0950M5	4813974A21	R4317M1	0613952R66
D0951M5	4813974A21	RT0900M5	0615585H01
D3000M5	4813978P07	SH0000M2	26012095001
D3104M1	4885489Y01	SH0001M2	26012095001
D3160M1	4813978C02	SH0002M2	26012097001
D3161M1	4813978C02	SH0003M2	26012094001
E0000M2	24012107027	SH0004M2	26012094001
E0001M2	24012107027	SH0200M7	26012095001
E0002M2	NOT PLACED	SH0300M7	26012095001
E0003M2	24012107027	SH0400M4	26012096001
E0004M2	24012107027	SH0401M4	26012096001
E0005M2	24012107027	SH0402M4	26012098001
E0006M2	24012107027	SH0403M4	26012098001
E0007M2	24012107027	SH0500M3	26012098001
E0008M2	24012107027	SH0501M3	NOT PLACED
E0009M2	24012107027	SH0900M5	2686425Z02
E0010M2	24012107027	SH0901M5	2686425Z02
E0200M7	24012107027	SH0902M5	26012100001
E0300M7	24012107027	SH3100M1	NOT PLACED
E0401M4	24012107027	SP3000M5	NOT PLACED

Circuit Ref.	Motorola Solutions Part No.	Circuit Ref.	Motorola Solutions Part No.
E0402M4	24012107027	SP3001M5	NOT PLACED
E0403M4	24012107027	T0000M2	25012016001
E0404M4	24012107027	T0400M4	2515121H01
E0500M3	24012107027	T0401M4	2515121H01
E0700M5	24012102001	U0000M2	51009877001
E0701M5	24012102001	U0001M2	5109731C48
E0703M5	24012102001	U0002M2	4802197J95
E1000M1	7686949J15	U0200M7	5186310Y39
E1001M1	7686949J15	U0500M3	4802197J95
E1002M1	7686949J15	U0901M5	5180390L83
E1003M1	7686949J15	U0902M5	51012221001
E1004M1	7686949J15	U0903M5	5115022H01
E1005M1	7686949J15	U0904M5	5109731C48
E1006M1	7685268E01	U0905M5	5109731C48
E3000M5	24012102001	U1000M1	5171320H01
E3100M1	24012102001	U1001M1	51012295001
E3101M1	2485410Y02	U1002M1	5189139P01
E3102M1	2485410Y02	U1003M1	5175772B56
E3103M1	2485410Y02	U1004M1	5175772B56
E3104M1	7686949J22	U1005M1	5164852H47
E3105M1	7686949J22	U1006M1	5185493Y01
E3106M1	7686949J22	U1007M1	5189139P01
E3107M1	7686949J22	U1008M1	5189139P01
E3108M1	7686949J22	U1009M1	5115001H02
E3109M1	7686949J22	U1010M1	5171320H01
E3110M1	7686949J22	U2000M1	MM000157A01
E3111M1	7686949J22	U2001M1	MM000129A01
E3113M1	7686949J22	U3000M5	5116525H01
E3200M1	24012102001	U3001M5	4813973M07
E3201M1	24012102001	U3002M5	51012133001
E3202M1	24012107027	U3100M1	0104039J08
E3203M1	24012102001	U3101M1	5114014A01
E3204M1	24012102001	U3102M1	51012069001
E4000M1	24012107027	U3103M1	51012142001
E4001M1	7688697V05	U3104M1	5171590Y73

Circuit Ref.	Motorola Solutions Part No.	Circuit Ref.	Motorola Solutions Part No.
E4002M1	24012107027	U3105M1	5114610F01
E4003M1	NOT PLACED	U3106M1	51012140001
E4004M1	24012102001	U3107M1	51012140001
E4005M1	2485410Y02	U3108M1	51012138001
E4100M1	7686949J14	U3109M1	5164015H94
E4101M1	24012107027	U3110M1	51012208001
E4102M1	NOT PLACED	U3111M1	5188690V02
E4103M1	NOT PLACED	U3112M1	5114004A35
E4104M1	NOT PLACED	U3113M1	5188690V02
E4200M1	24012107027	U3114M1	NOT PLACED
E4201M1	24012107027	U3115M1	5185937Y01
E4202M1	24012107027	U3200M1	51009415001
E4300M1	24012107027	U3201M1	5114016A18
E4405M1	24012107027	U3204M1	51009509001
E4406M1	7686949J22	U3205M1	5114016A18
E4407M1	7686949J22	U4000M1	51012082001
E4408M1	24012107027	U4001M1	51012082001
E4409M1	24012102001	U4100M1	5189139P01
F4000M1	65012019001	U4200M1	NOT PLACED
FL0500M3	9116854H02	U4201M1	NOT PLACED
FL4000M1	24012038001	U4300M1	51012082001
FL4001M1	24012038001	U4301M1	51012082001
J4000M1	0915767H01	VR0001M2	4815096H01
J4001M1	0915556H01	VR0200M7	4805656W87
J4100M1	0916017H01	VR0201M7	4805656W87
J4200M1	09012053001	VR0202M7	4805656W87
J4400M1	09012053001	VR0203M7	4805656W87
L0000M2	24012154001	VR0204M7	4805656W87
L0001M2	24667008020	VR0205M7	4805656W87
L0002M2	24667000031	VR0206M7	4805656W87
L0003M2	24667008031	VR0207M7	4805656W87
L0004M2	24009343017	VR0208M7	4805656W87
L0005M2	24667008017	VR0209M7	4805656W87
L0200M7	24667008031	VR0210M7	4805656W87
L0201M7	24667008031	VR0211M7	4805656W87

Circuit Ref.	Motorola Solutions Part No.	Circuit Ref.	Motorola Solutions Part No.
L0202M7	2415385H02	VR0214M7	4805656W87
L0203M7	24009343013	VR0215M7	4805656W87
L0204M7	24667008031	VR0400M4	4805656W87
L0205M7	24667008031	VR0401M4	4805656W87
L0206M7	24667008031	VR0402M4	4805656W87
L0207M7	24667008031	VR0403M4	4805656W87
L0208M7	24667008031	VR0404M4	4805656W87
L0209M7	24667008031	VR0405M4	4805656W87
L0210M7	24009343006	VR0406M4	4805656W87
L0211M7	2415385H01	VR0407M4	4805656W87
L0212M7	24667008031	VR3000M5	48012202001
L0214M7	24009343006	VR3002M5	4813977M10
L0216M7	2415385H02	VR3103M1	48012095001
L0218M7	24667008031	VR3104M1	48012095002
L0220M7	24667008031	VR3105M1	4813977M10
L0222M7	24667008031	VR3200M1	48012049001
L0224M7	24667008030	VR3201M1	4813977A48
L0226M7	24667008021	VR3202M1	4813977A48
L0300M7	24667008014	VR4000M1	4813977M13
L0301M7	24667008031	VR4001M1	4813977A48
L0302M7	24667008030	VR4002M1	48012153001
L0303M7	24667008013	VR4100M1	4813977A48
L0304M7	24667008019	VR4101M1	4813977A48
L0305M7	24667008014	VR4102M1	4813977A48
L0401M4	24012021001	VR4103M1	4813977A48
L0402M4	24009344102	VR4104M1	48012049001
L0403M4	24667008030	VR4105M1	4813977M13
L0404M4	24009344109	VR4106M1	4813977A48
L0405M4	2416540H31	VR4107M1	4813977A48
L0406M4	24012021001	VR4108M1	4813977A48
L0407M4	24012021001	VR4109M1	4813977A50
L0408M4	24667008030	VR4110M1	4815040H01
L0409M4	24667008030	VR4111M1	48012153001
L0410M4	24667008025	Y0000M2	4875185M05
L0411M4	24012021001	-	-



NOTICE: The suffix "M1", "M2", and so on from the Circuit Ref. is removed from the schematic and overlays.

8.5.1.3

Circuit Board and Schematic Diagrams for 84012735003-C

Figure 188: Main Board Top Side PCB No. 84012735003-C

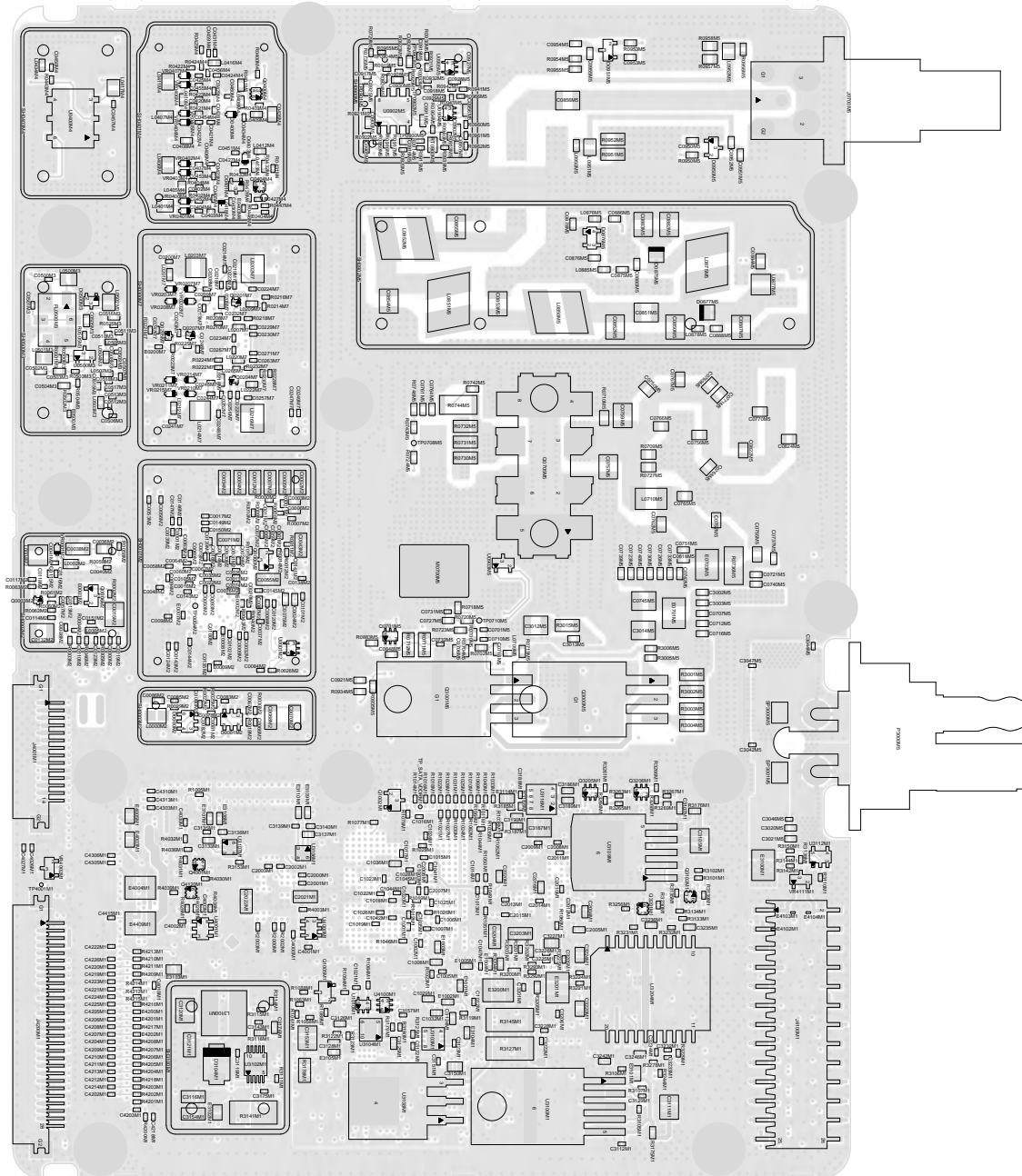

Figure 189: Main Board Bottom Side PCB No. 84012735003-C

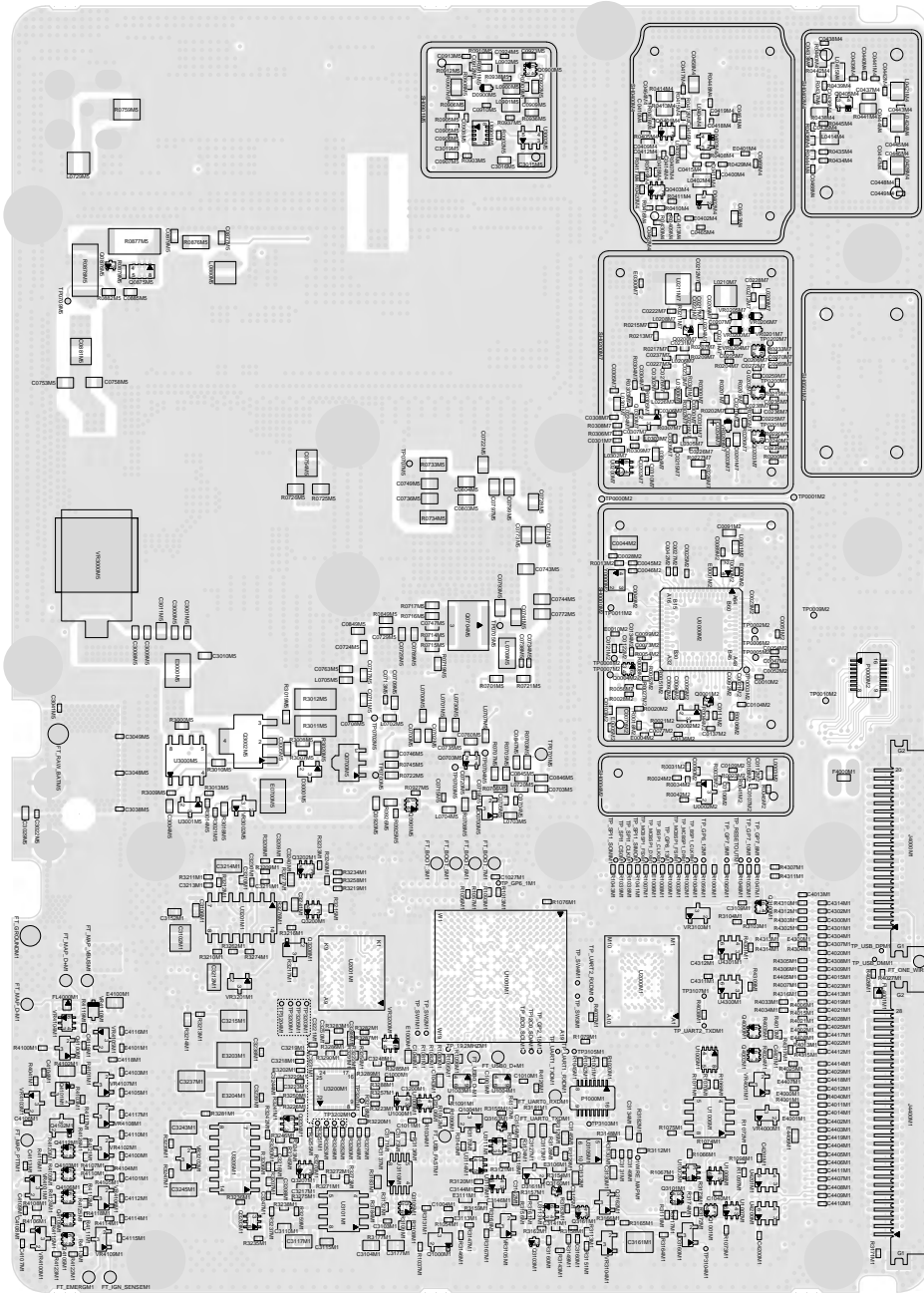

Figure 190: Overall Schematic Diagram

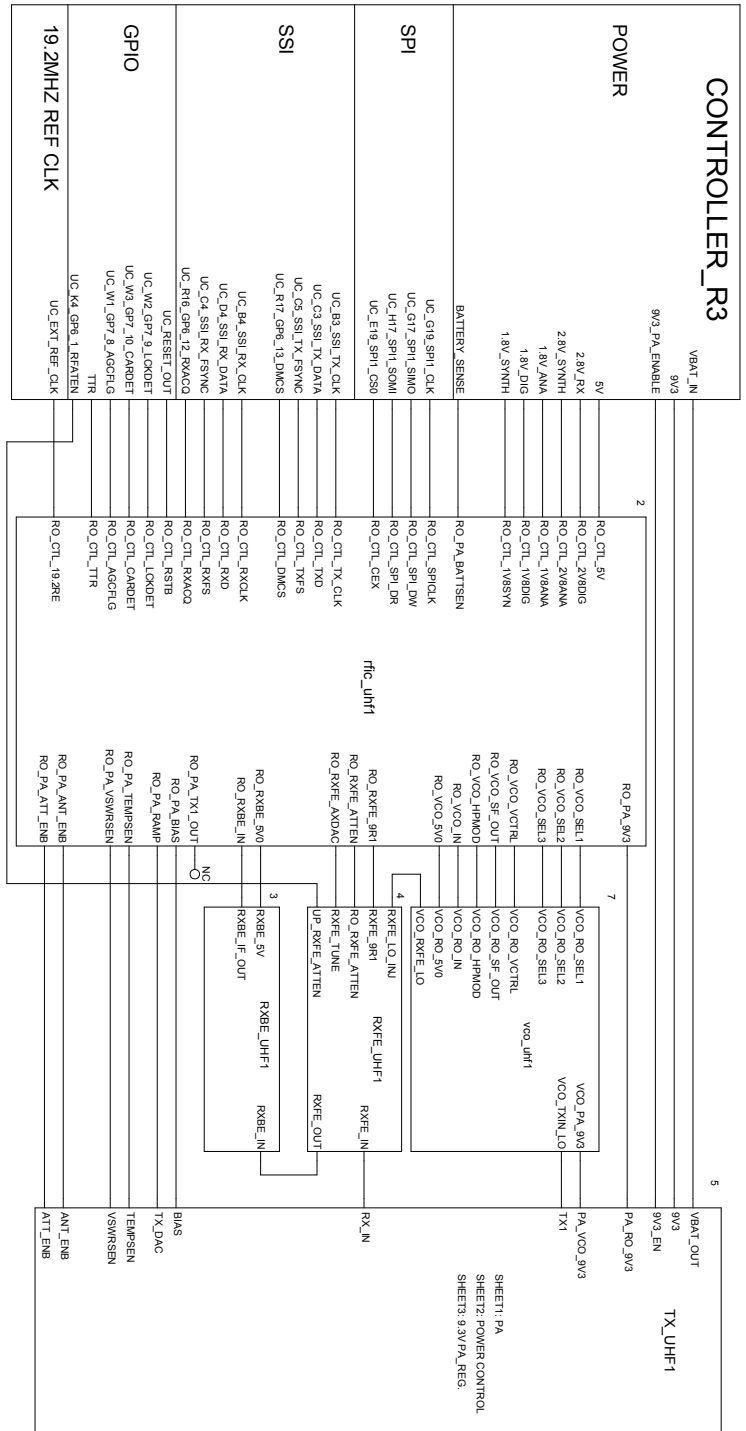

Figure 191: Receiver Front-End Schematic Diagram

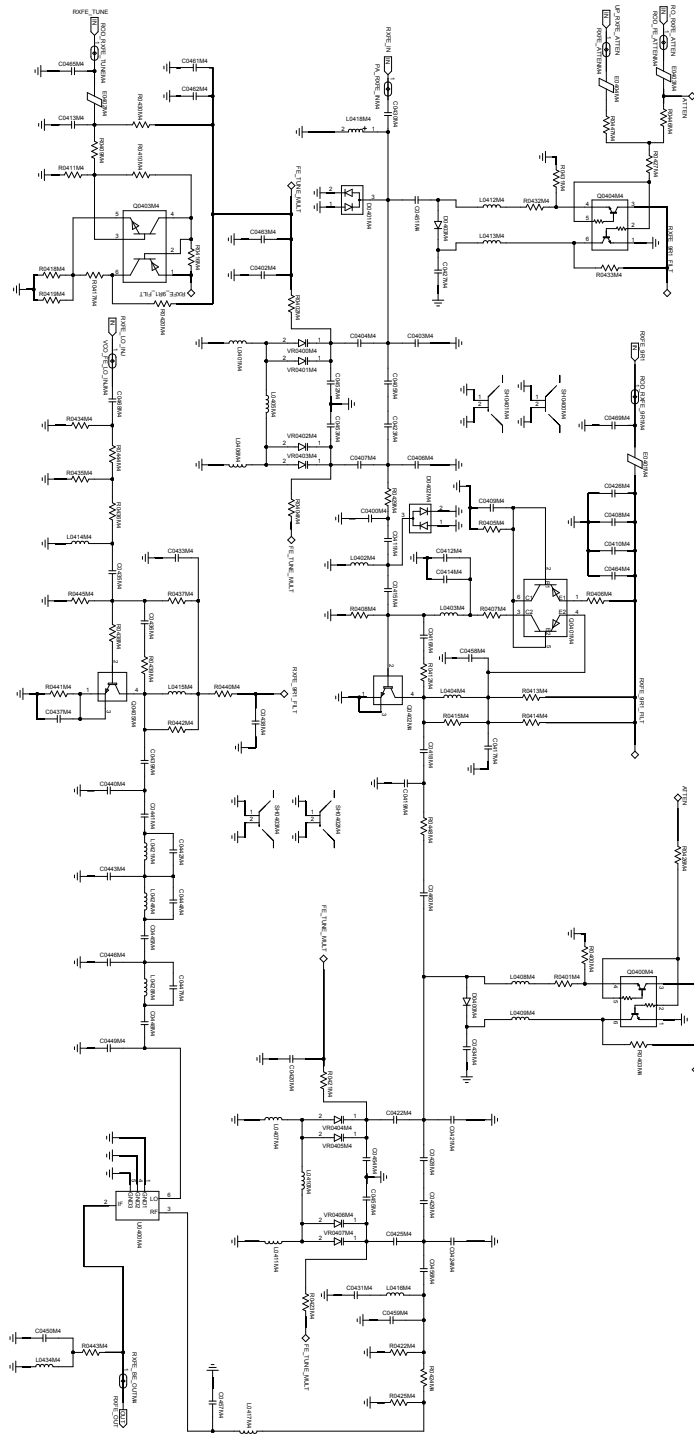

Figure 192: Receiver IF Amp Schematic Diagram

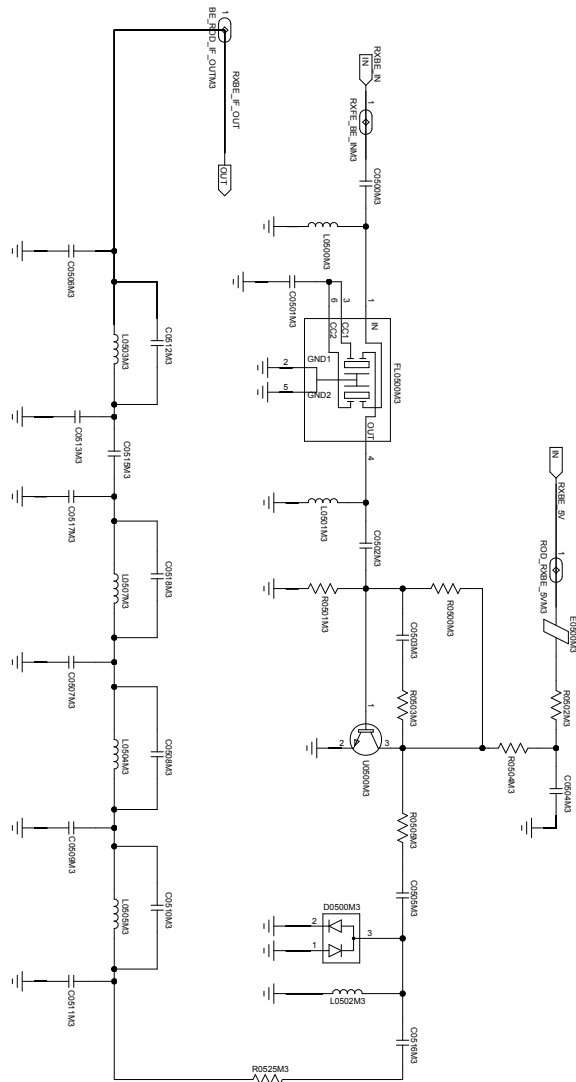
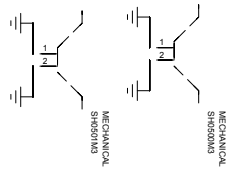

Figure 193: Transmitter Power Amplifier Schematic Diagram

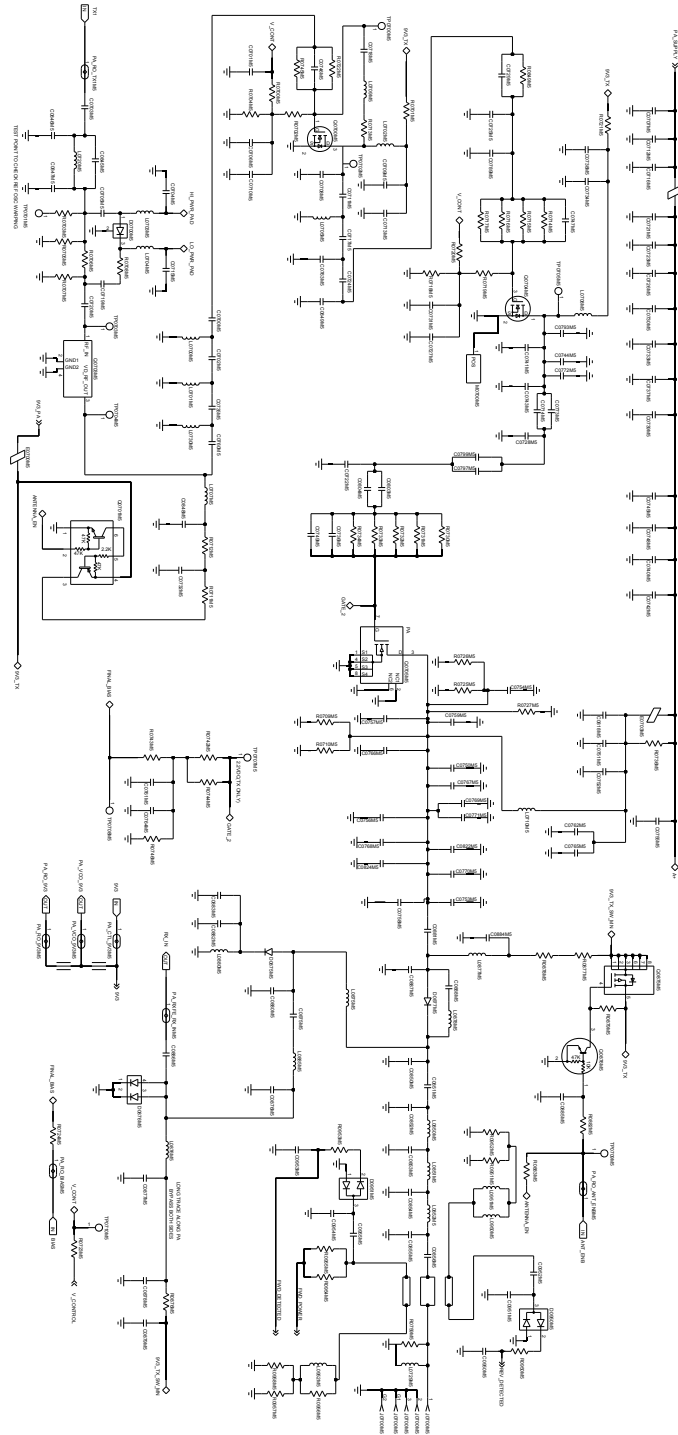
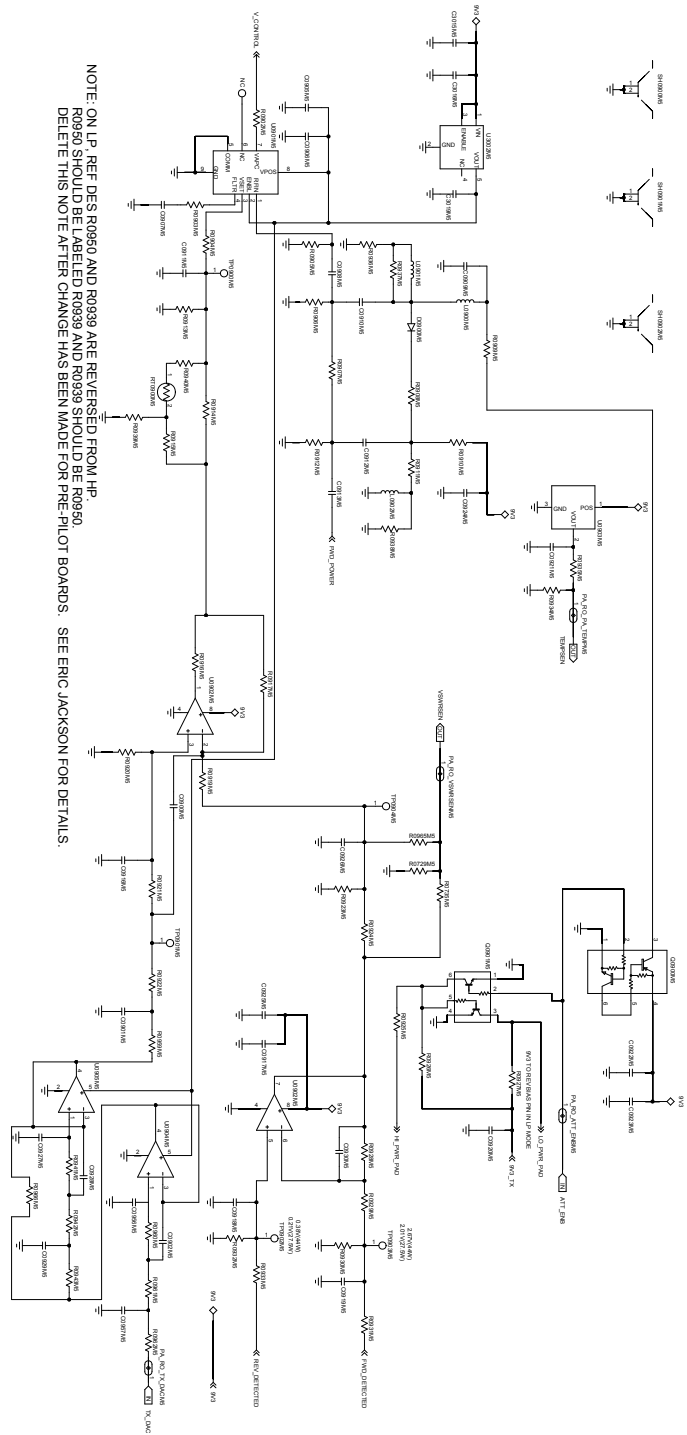

Figure 194: Power Control Schematic Diagram



NOTE: VOLTAGE SHOWN FOR ANALOG TX MODE

Figure 196: RFIC Schematic Diagram

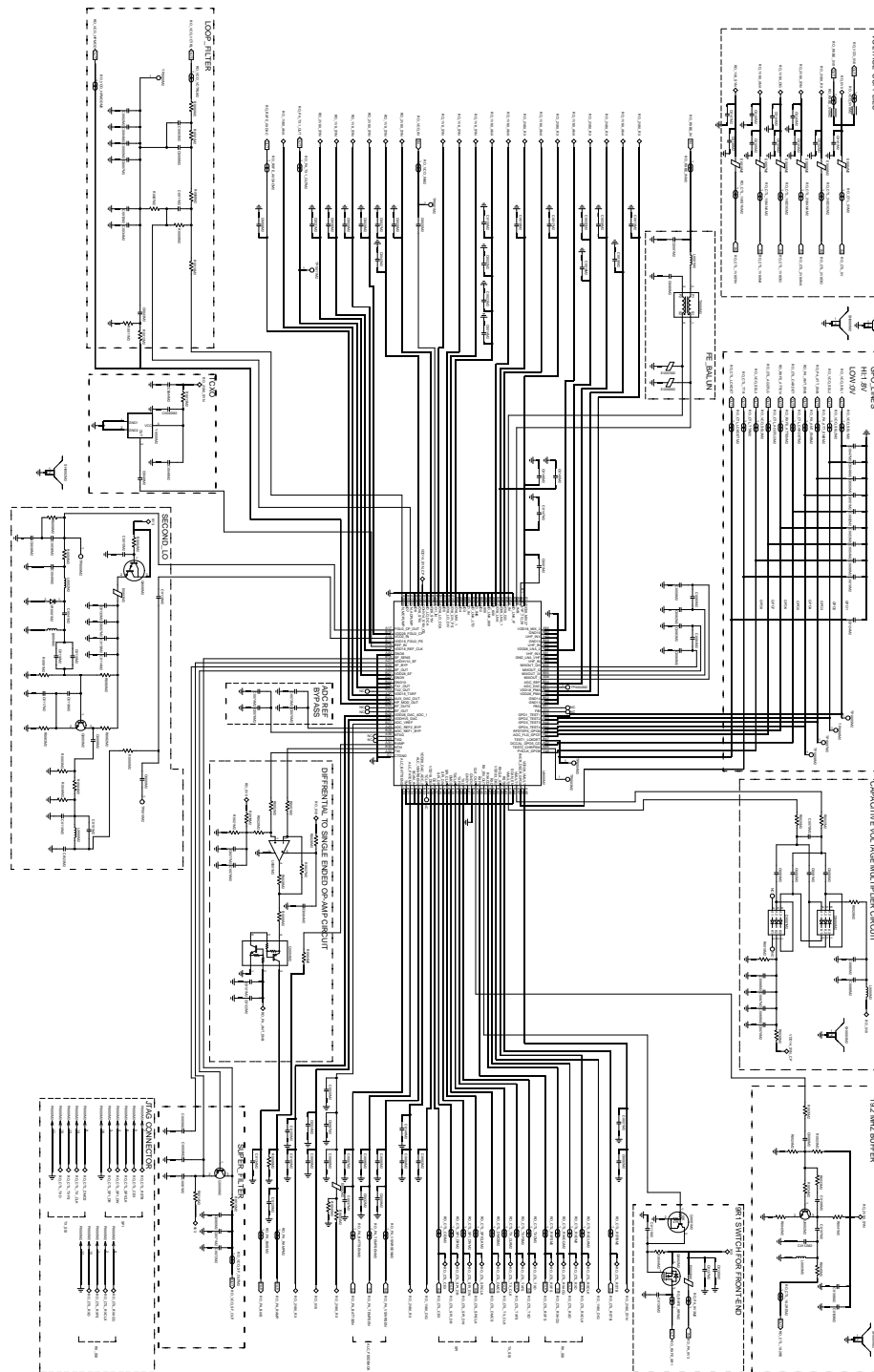
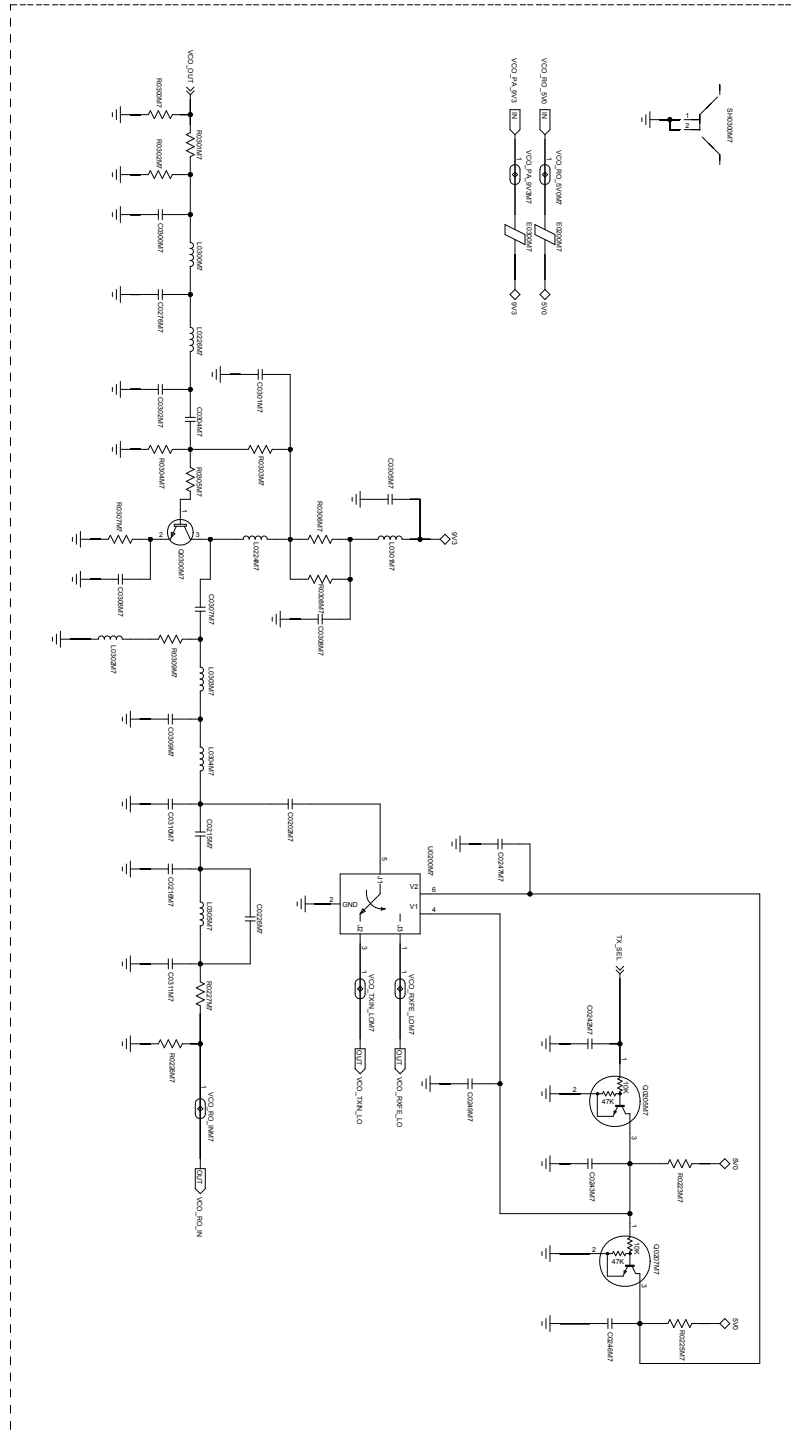

Figure 199: VCO Buffer Schematic Diagram



8.5.1.4

Parts List for 84012735003-C

Table 22: UHF1 Radio Parts List

Circuit Ref.	Motorola Solutions Part No.	Circuit Ref.	Motorola Solutions Part No.
C0000M2	21667009311	D3000M6	4813978P07
C0001M2	21667009170	E0000M2	24012107027
C0002M2	21012044001	E0001M2	24012107027
C0003M2	NOT PLACED	E0002M2	NOT PLACED
C0004M2	21012044001	E0003M2	24012107027
C0005M2	21012044001	E0004M2	24012107027
C0006M2	2113945C31	E0005M2	24012107027
C0007M2	21012044001	E0006M2	24012107027
C0008M2	21667009311	E0007M2	24012107027
C0009M2	21667009166	E0008M2	24012107027
C0010M2	21667009166	E0009M2	24012107027
C0011M2	2113945C31	E0010M2	24012107027
C0012M2	21012044001	E0200M7	24012107027
C0013M2	2113945Y02	E0300M7	24012107027
C0014M2	2113945Y02	E0401M4	24012107027
C0015M2	2113946J03	E0402M4	24012107027
C0016M2	2113945A10	E0403M4	24012107027
C0017M2	2113945Y02	E0404M4	24012107027
C0018M2	2113945A10	E0500M3	24012107027
C0019M2	2113945Y02	E0700M5	24012102001
C0020M2	2113945A10	E0701M5	24012102001
C0021M2	2113945Y02	E0703M5	24012102001
C0022M2	2113945Y02	E3000M5	24012102001
C0023M2	2113945Y02	E3000M6	24012102001
C0024M2	21012102001	FL0500M3	9116854H03
C0025M2	21667009166	J0700M5	09009348002
C0026M2	21667009174	L0000M2	24012154001
C0027M2	2113945Y02	L0001M2	24667008020
C0028M2	2113945Y02	L0002M2	24667000031
C0029M2	2113945A10	L0003M2	24667008031
C0030M2	2113945A10	L0004M2	24009343017
C0031M2	2113945Y02	L0005M2	24667008017

Circuit Ref.	Motorola Solutions Part No.	Circuit Ref.	Motorola Solutions Part No.
C0032M2	21667009166	L0200M7	24667008031
C0034M2	21012044001	L0201M7	24667008031
C0035M2	21667009166	L0202M7	2415385H02
C0036M2	21012025001	L0203M7	24009343013
C0037M2	21667009166	L0204M7	24667008031
C0038M2	21012044001	L0205M7	24667008031
C0039M2	2113945Y02	L0206M7	24667008031
C0040M2	2113945A10	L0207M7	24667008031
C0041M2	21667009364	L0208M7	24667008031
C0042M2	21667009166	L0209M7	24667008031
C0043M2	21012044002	L0210M7	24009343006
C0044M2	2113955D45	L0211M7	2415385H01
C0045M2	2113945Y02	L0212M7	24667008031
C0046M2	21667009166	L0214M7	24009343006
C0047M2	21667009166	L0216M7	2415385H02
C0048M2	21667009166	L0218M7	24667008031
C0049M2	2113945B02	L0220M7	24667008031
C0050M2	21667009166	L0222M7	24667008031
C0051M2	21667009166	L0224M7	24667008030
C0052M2	21667009166	L0226M7	24667008021
C0053M2	21667009166	L0300M7	24667008014
C0054M2	21667009166	L0301M7	24667008031
C0055M2	2113955D37	L0302M7	24667008030
C0056M2	2113945Y02	L0303M7	24667008013
C0057M2	2113945B02	L0304M7	24667008019
C0058M2	NOT PLACED	L0305M7	24667008014
C0059M2	21667009166	L0401M4	24012021001
C0060M2	2113945A69	L0402M4	24009344102
C0061M2	2113945Y02	L0403M4	24667008030
C0062M2	NOT PLACED	L0404M4	24009344123
C0063M2	NOT PLACED	L0405M4	2416540H31
C0064M2	2113945A69	L0406M4	24012021001
C0065M2	2113945Y02	L0407M4	24012021001
C0066M2	2113945B02	L0408M4	24667008030
C0067M2	2113945Y02	L0409M4	24667008030

Circuit Ref.	Motorola Solutions Part No.	Circuit Ref.	Motorola Solutions Part No.
C0068M2	2113955D37	L0410M4	24667008025
C0069M2	NOT PLACED	L0411M4	24012021001
C0070M2	2113955D37	L0412M4	24667008030
C0071M2	2113955D37	L0413M4	24667008030
C0072M2	21667009166	L0414M4	24009344106
C0073M2	21667009166	L0415M4	24009344108
C0074M2	21667009166	L0416M4	24667008017
C0075M2	2113946S35	L0417M4	24009344107
C0076M2	2113946S35	L0418M4	NOT PLACED
C0077M2	21667009166	L0421M4	24009344106
C0078M2	21667009372	L0424M4	24009344106
C0079M2	2113955D37	L0428M4	24009344106
C0080M2	2113945B02	L0434M4	24667008021
C0081M2	2113945B02	L0500M3	24009344127
C0082M2	2113945B02	L0501M3	24009344128
C0083M2	2113945B02	L0502M3	24009344126
C0084M2	21667009166	L0503M3	24667008021
C0085M2	21667009166	L0504M3	24667008026
C0086M2	2113945C31	L0505M3	24667008026
C0087M2	2113946S35	L0507M3	24667008024
C0088M2	2113945Y02	L0700M5	NOT PLACED
C0089M2	2113945Y02	L0701M5	24667008007
C0090M2	2113945B02	L0702M5	24667008028
C0091M2	2113944C82	L0703M5	24667008028
C0092M2	21667009166	L0704M5	24667008028
C0093M2	2113945Y02	L0705M5	24667008007
C0094M2	2113945Y02	L0707M5	24667008028
C0095M2	2113945A13	L0708M5	2479990G01
C0096M2	2113945B02	L0709M5	NOT PLACED
C0097M2	2113945B02	L0710M5	2460591C53
C0098M2	21667009166	L0720M5	24667008014
C0099M2	2113945Y02	L0729M5	2414032B60
C0100M2	2113945Y02	L0730M5	24667008014
C0101M2	21667009166	L0850M5	2460592A01
C0102M2	21667009166	L0851M5	2460592A01

Circuit Ref.	Motorola Solutions Part No.	Circuit Ref.	Motorola Solutions Part No.
C0103M2	21667009166	L0852M5	2460592A01
C0104M2	21667009166	L0875M5	2460592A01
C0105M2	21667009166	L0876M5	24667008029
C0106M2	2113945B02	L0877M5	2414032B49
C0107M2	2113945B02	L0878M5	24667008024
C0108M2	21667009166	L0880M5	2414032B49
C0109M2	2113945Y02	L0885M5	24667008014
C0110M2	21667009381	L0900M5	24667000031
C0111M2	2113945Y02	L0901M5	24009344018
C0112M2	21667009166	L0902M5	24667000031
C0113M2	21667009166	L0950M5	24667008024
C0114M2	2113945Y02	L0951M5	24009344003
C0115M2	21667009370	L0952M5	24009344026
C0116M2	NOT PLACED	M0700M5	2686201B02
C0117M2	21667009374	P0000M2	NOT PLACED
C0118M2	21667009375	P3000M5	9009344001
C0119M2	2113945A10	P3000M6	09009344001
C0120M2	21667009166	Q0000M2	4813973A13
C0121M2	NOT PLACED	Q0001M2	48009494001
C0122M2	21667009166	Q0002M2	4813970A59
C0123M2	21667009381	Q0003M2	4885316E32
C0124M2	21667009166	Q0004M2	4815272H01
C0132M2	2113946J03	Q0006M2	4813973A04
C0134M2	21667009166	Q0200M7	4885316E32
C0135M2	21667009166	Q0201M7	4885316E32
C0136M2	21667009166	Q0202M7	4815272H01
C0137M2	2113945Y02	Q0203M7	4815272H01
C0138M2	21667009166	Q0204M7	4885316E32
C0139M2	21667009166	Q0205M7	48009494001
C0140M2	2113945Y02	Q0206M7	4815272H01
C0141M2	2113945Y02	Q0207M7	48009494001
C0143M2	2113945Y02	Q0300M7	4802197J95
C0144M2	2113945Y02	Q0400M4	4815271H01
C0145M2	21667009166	Q0401M4	4815267H01
C0146M2	2113945A10	Q0402M4	48012201001

Circuit Ref.	Motorola Solutions Part No.	Circuit Ref.	Motorola Solutions Part No.
C0147M2	2113945A10	Q0403M4	4815270H01
C0149M2	21667009166	Q0404M4	4815271H01
C0150M2	21667009166	Q0405M4	48012201001
C0151M2	21667009368	Q0700M5	CR001114A01
C0200M7	21667009166	Q0701M5	4816013H01
C0201M7	NOT PLACED	Q0703M5	4802246J29
C0202M7	21667009166	Q0704M5	CR001116A01
C0203M7	NOT PLACED	Q0705M5	CR001117A01
C0204M7	NOT PLACED	Q0875M5	4813970A62
C0205M7	21667009274	Q0876M5	48009494001
C0206M7	21667009366	Q0900M5	4815272H01
C0207M7	21667009365	Q0901M5	4815271H01
C0208M7	21667009311	Q3000M5	0105959T72
C0209M7	21667009311	Q3000M6	0105959T72
C0210M7	21667009274	Q3001M5	0105959T72
C0211M7	NOT PLACED	Q3001M6	0105959T72
C0212M7	21667009294	Q3002M5	4813973B01
C0213M7	21667009274	Q3002M6	4813973B01
C0214M7	NOT PLACED	R0000M2	0613952R66
C0215M7	21667009315	R0001M2	0613952R66
C0216M7	21667009311	R0002M2	0613952Q96
C0217M7	21667009346	R0003M2	0613952Q57
C0218M7	21667009334	R0004M2	0613952Q34
C0219M7	21667009378	R0005M2	0613952R66
C0220M7	21667009380	R0006M2	0613952Q25
C0221M7	21667009371	R0007M2	0613952Q51
C0222M7	21667009366	R0008M2	0613952R01
C0223M7	21667009370	R0009M2	0613952Q58
C0224M7	21667009369	R0010M2	0613952R66
C0225M7	2113945Y02	R0011M2	0613952Q36
C0226M7	21667009311	R0012M2	0613952Q86
C0227M7	2113945Y02	R0013M2	0613952Q35
C0228M7	21667009166	R0014M2	0613952R66
C0229M7	21667009166	R0015M2	0613952R66
C0230M7	21667009166	R0018M2	0613952Q80

Circuit Ref.	Motorola Solutions Part No.	Circuit Ref.	Motorola Solutions Part No.
C0231M7	21667009166	R0019M2	0613952R01
C0232M7	21667009166	R0020M2	0613952R12
C0233M7	21667009284	R0021M2	0613952Q80
C0234M7	21667009315	R0022M2	0613952R66
C0235M7	21667009166	R0023M2	0613952Q83
C0236M7	2113945Y02	R0024M2	0613952Q80
C0237M7	21667009166	R0025M2	0613952R66
C0238M7	2113945Y02	R0026M2	0613952R66
C0239M7	2113945Y02	R0027M2	0613952R12
C0240M7	21667009166	R0028M2	0613952R66
C0241M7	21667009166	R0029M2	0613952Q25
C0242M7	21667009166	R0030M2	0613952R66
C0243M7	21667009166	R0031M2	0613952R66
C0244M7	21667009332	R0033M2	0613952R01
C0245M7	21667009332	R0034M2	0613952Q57
C0246M7	21667009166	R0040M2	0613952Q70
C0247M7	21667009166	R0041M2	0613952Q58
C0248M7	21667009326	R0042M2	0613952Q42
C0249M7	21667009166	R0043M2	0613952Q73
C0252M7	21667009339	R0044M2	0613952R25
C0256M7	21667009371	R0045M2	0613952R66
C0257M7	21667009366	R0046M2	0613952Q57
C0259M7	2113945Y02	R0051M2	0613952R01
C0263M7	21667009166	R0052M2	0613952R01
C0265M7	21667009166	R0054M2	0613952M25
C0267M7	21667009297	R0056M2	0613952R66
C0269M7	21667009166	R0058M2	0613952Q74
C0270M7	2113945Y02	R0059M2	0613952R66
C0271M7	21667009166	R0060M2	0613952Q89
C0272M7	2113945Y02	R0061M2	0613952Q85
C0276M7	21667009311	R0062M2	0613952Q61
C0300M7	NOT PLACED	R0063M2	0613952Q64
C0301M7	NOT PLACED	R0200M7	0613952R66
C0302M7	21667009286	R0201M7	0613952R27
C0304M7	21667009390	R0202M7	0613952R27

Circuit Ref.	Motorola Solutions Part No.	Circuit Ref.	Motorola Solutions Part No.
C0305M7	2113945Y02	R0203M7	0613952R07
C0306M7	2113945B02	R0204M7	0613952R05
C0307M7	21667009390	R0205M7	0613952R07
C0308M7	2113945B02	R0206M7	0613952R05
C0309M7	21667009280	R0207M7	0613952Q84
C0310M7	21667009279	R0208M7	0613952Q87
C0311M7	21667009346	R0209M7	0613952Q85
C0400M4	NOT PLACED	R0210M7	0613952Q79
C0402M4	21667009166	R0211M7	0613952Q18
C0403M4	21667009297	R0212M7	0613952Q32
C0404M4	21667009368	R0213M7	0613952Q67
C0405M4	21667009284	R0214M7	0613952Q67
C0406M4	21667009297	R0215M7	0613952Q67
C0407M4	21667009368	R0216M7	0613952Q67
C0408M4	2113945C31	R0217M7	0613952Q49
C0409M4	2113945C31	R0218M7	0613952Q49
C0410M4	21667009166	R0219M7	0613952R66
C0411M4	21667009307	R0220M7	0613952R66
C0412M4	2113946F05	R0221M7	0613952R66
C0413M4	21667009166	R0222M7	0613952Z41
C0414M4	21667009166	R0223M7	0613952Q73
C0415M4	21667009364	R0224M7	0613952Z38
C0416M4	2113945C31	R0225M7	0613952Q73
C0417M4	21667009166	R0226M7	0613952Q24
C0418M4	21667009415	R0227M7	0613952G67
C0419M4	21667009274	R0228M7	0613952Q67
C0420M4	21667009166	R0230M7	0613952Q67
C0421M4	21667009297	R0232M7	0613952Q49
C0422M4	21667009368	R0233M7	0613952R66
C0423M4	21667009280	R0300M7	0613952Q66
C0424M4	21667009297	R0301M7	0613952Q25
C0425M4	21667009368	R0302M7	0613952Q66
C0426M4	2113946F05	R0303M7	0613952R05
C0427M4	21667009372	R0304M7	0613952Q89
C0428M4	21667009284	R0305M7	0613952Q33

Circuit Ref.	Motorola Solutions Part No.	Circuit Ref.	Motorola Solutions Part No.
C0429M4	21667009280	R0306M7	0613952Q32
C0430M4	21667009161	R0307M7	0613952Q49
C0431M4	21667009368	R0308M7	0613952Q32
C0433M4	21667009166	R0309M7	0613952Q42
C0434M4	21667009384	R0400M4	0613952R01
C0435M4	21667009380	R0401M4	0613952H73
C0436M4	21667009166	R0402M4	0613952R25
C0437M4	2113945C31	R0403M4	0613952R01
C0438M4	21667009166	R0404M4	0613952R25
C0439M4	21667009346	R0405M4	0613952Q76
C0440M4	21667009315	R0406M4	0613952Q89
C0441M4	21667009372	R0407M4	0613952Q73
C0442M4	21667009277	R0408M4	0613952Q75
C0443M4	21667009364	R0409M4	0613952Q69
C0444M4	21667009286	R0410M4	0613952R01
C0445M4	21667009368	R0411M4	0613952R01
C0446M4	21667009355	R0412M4	0613952Q89
C0447M4	21667009277	R0413M4	0613958H59
C0448M4	21667009372	R0414M4	NOT PLACED
C0449M4	21667009315	R0415M4	0613952Q52
C0450M4	21667009388	R0416M4	0613952Q69
C0451M4	21667009166	R0417M4	0613952Q69
C0452M4	21667009366	R0418M4	0613952Q69
C0453M4	21667009366	R0419M4	0613952Q69
C0454M4	21667009366	R0420M4	0613952R25
C0455M4	21667009366	R0421M4	0613952R25
C0456M4	21667009355	R0422M4	0613952Q67
C0457M4	21667009339	R0423M4	0613952R25
C0458M4	2113946F05	R0424M4	0613952Q23
C0459M4	21667009307	R0425M4	0613952Q67
C0460M4	0613952R66	R0426M4	0613952Q87
C0461M4	NOT PLACED	R0427M4	0613952Q93
C0462M4	21667009159	R0429M4	0613952R66
C0463M4	NOT PLACED	R0430M4	NOT PLACED
C0464M4	21667009158	R0431M4	0613952R01

Circuit Ref.	Motorola Solutions Part No.	Circuit Ref.	Motorola Solutions Part No.
C0465M4	21667009166	R0432M4	0613952H73
C0468M4	21667009166	R0433M4	0613952R01
C0469M4	21667009166	R0434M4	0613952L46
C0500M3	21667009369	R0435M4	0613952L46
C0501M3	21667009332	R0436M4	0613952R66
C0502M3	2113944M21	R0437M4	0613952Q77
C0503M3	2113945C31	R0438M4	0613958H25
C0504M3	2113945C31	R0439M4	0613952Q83
C0505M3	21667011351	R0440M4	0613958H25
C0506M3	NOT PLACED	R0441M4	0613958H49
C0507M3	21667009374	R0442M4	0613952Q83
C0508M3	21667009366	R0443M4	0613952Q25
C0509M3	21667009382	R0444M4	0613952K25
C0510M3	21667009366	R0445M4	0613952Q75
C0511M3	21667009355	R0446M4	NOT PLACED
C0512M3	21667009303	R0447M4	0613952R66
C0513M3	21667009368	R0448M4	0613952Q35
C0515M3	21667009383	R0500M3	0613952Q87
C0516M3	21667011464	R0501M3	0613952R19
C0517M3	21667009315	R0502M3	0613952Q66
C0518M3	21667009339	R0503M3	0613952Q88
C0700M5	2113944C46	R0504M3	0613952Q61
C0701M5	21667009163	R0505M3	0613952R66
C0702M5	2113944C38	R0525M3	0613952R66
C0703M5	2113944C42	R0700M5	0613952J05
C0704M5	21667009163	R0701M5	0613952G67
C0705M5	21667009163	R0702M5	0613952H89
C0706M5	NOT PLACED	R0703M5	0613952J01
C0707M5	2113944C82	R0704M5	0613952J06
C0708M5	NOT PLACED	R0705M5	0613952H47
C0709M5	2113945C04	R0706M5	0613952H54
C0710M5	21667009163	R0707M5	0613952H47
C0711M5	2113944C46	R0708M5	0613952H45
C0712M5	2113945C04	R0709M5	0613958J49
C0713M5	21667009163	R0710M5	0613958J49

Circuit Ref.	Motorola Solutions Part No.	Circuit Ref.	Motorola Solutions Part No.
C0714M5	2113944F47	R0711M5	0613958S44
C0715M5	21667009163	R0712M5	0613958S44
C0716M5	2113944C55	R0713M5	NOT PLACED
C0717M5	2113944C82	R0714M5	0613952H09
C0718M5	NOT PLACED	R0715M5	0613952H09
C0719M5	21667009163	R0716M5	0613952H09
C0720M5	2113944C42	R0717M5	0613952H09
C0721M5	2113944C82	R0718M5	0613952H94
C0722M5	2113944F44	R0719M5	0613952H89
C0723M5	2113945C04	R0720M5	0613952H95
C0724M5	2113944C83	R0721M5	0613952G67
C0725M5	2113944C38	R0722M5	0613952H25
C0726M5	2113944C51	R0723M5	0613952G67
C0727M5	NOT PLACED	R0724M5	0613952G67
C0728M5	2113944F39	R0725M5	0613958J49
C0729M5	NOT PLACED	R0726M5	0613958J49
C0730M5	NOT PLACED	R0727M5	0613958J49
C0731M5	21667009163	R0729M5	0613952N43
C0732M5	2113945A09	R0730M5	NOT PLACED
C0733M5	NOT PLACED	R0731M5	NOT PLACED
C0734M5	2113945A09	R0732M5	NOT PLACED
C0735M5	2113944C30	R0733M5	0613958S29
C0736M5	2113944F64	R0734M5	0613958S29
C0737M5	2113944C51	R0735M5	0613952P01
C0738M5	21667009163	R0736M5	0613959Q25
C0739M5	2113945C31	R0742M5	NOT PLACED
C0740M5	2113944C51	R0743M5	0613952J17
C0741M5	2113944F53	R0744M5	0613959Q42
C0742M5	2113945L49	R0745M5	0613952H25
C0743M5	2113944F56	R0746M5	0613952J25
C0744M5	2113944F52	R0759M5	0613959H12
C0745M5	21009337414	R0849M5	0613952G67
C0746M5	NOT PLACED	R0876M5	0613958S73
C0747M5	2113944C44	R0877M5	0613959Y37
C0748M5	NOT PLACED	R0878M5	0613959Y37

Circuit Ref.	Motorola Solutions Part No.	Circuit Ref.	Motorola Solutions Part No.
C0749M5	2113944F64	R0879M5	0613952J25
C0750M5	2111078A25	R0882M5	0613952G67
C0751M5	NOT PLACED	R0883M5	0613952G67
C0752M5	NOT PLACED	R0902M5	0613952R66
C0753M5	2111078A21	R0903M5	0613952N01
C0754M5	2111078B33	R0904M5	0613952R66
C0755M5	NOT PLACED	R0905M5	0613952H42
C0756M5	2111078A25	R0906M5	0613958H46
C0757M5	2111078B32	R0907M5	0613958H55
C0758M5	NOT PLACED	R0908M5	0613952H42
C0759M5	2111078B31	R0909M5	0613952R66
C0760M5	2113944C80	R0910M5	0613952H91
C0761M5	2113944C45	R0911M5	0613952H85
C0762M5	2113944F01	R0912M5	0613958H46
C0763M5	2113944C34	R0913M5	0613952M51
C0764M5	2113944C51	R0914M5	0613952M71
C0765M5	2113944F01	R0915M5	NOT PLACED
C0766M5	NOT PLACED	R0916M5	0613952R66
C0767M5	NOT PLACED	R0917M5	0613952P01
C0768M5	NOT PLACED	R0919M5	0613952P01
C0769M5	2111078A21	R0920M5	0613952N01
C0770M5	2111078A06	R0921M5	0613952N01
C0771M5	2111078A21	R0922M5	0613952R66
C0772M5	2113944F52	R0923M5	0613952M42
C0773M5	2113944F47	R0924M5	0613952N01
C0789M5	2113944C38	R0925M5	0613952Q59
C0793M5	2113944F57	R0926M5	0613952H79
C0797M5	2113944F01	R0927M5	0613952N01
C0799M5	2113944F01	R0928M5	0613952N81
C0803M5	2113944F01	R0929M5	0613952N85
C0804M5	2113944F02	R0930M5	0613952N42
C0818M5	NOT PLACED	R0931M5	0613952M66
C0822M5	2111078A17	R0932M5	0613952N30
C0824M5	NOT PLACED	R0933M5	0613952N01
C0845M5	21667011411	R0934M5	0613952J17

Circuit Ref.	Motorola Solutions Part No.	Circuit Ref.	Motorola Solutions Part No.
C0846M5	21667011059	R0935M5	0613952H91
C0847M5	21667011059	R0936M5	0613952H91
C0848M5	2113944C45	R0937M5	NOT PLACED
C0849M5	2113944C35	R0938M5	NOT PLACED
C0850M5	2111078B05	R0939M5	0613952R66
C0851M5	2111078B21	R0940M5	0613952Z76
C0852M5	2111078B08	R0941M5	0613952N58
C0853M5	2111078B16	R0942M5	0613952N58
C0854M5	2111078B15	R0943M5	0613952N58
C0855M5	2111078B08	R0950M5	0613952G67
C0856M5	2111078B42	R0951M5	0613958M18
C0875M5	2113944C42	R0952M5	0613958M18
C0876M5	NOT PLACED	R0953M5	0613952G67
C0877M5	2113944C42	R0954M5	0613952H56
C0878M5	NOT PLACED	R0955M5	0613952H56
C0879M5	2113944C42	R0956M5	0613952H67
C0880M5	21667011073	R0957M5	0613958C25
C0881M5	2111078B42	R0958M5	0613958C25
C0882M5	2111078B22	R0959M5	0613952R66
C0883M5	2111078B34	R0960M5	0613952N58
C0884M5	2113944F15	R0961M5	0613952N58
C0885M5	2113944C51	R0962M5	0613952N58
C0886M5	2113944C47	R0965M5	NOT PLACED
C0887M5	NOT PLACED	R0966M5	NOT PLACED
C0888M5	2113944C42	R3000M5	0613952H60
C0900M5	NOT PLACED	R3000M6	0613952H60
C0901M5	NOT PLACED	R3001M5	0615871H01
C0902M5	2113944C51	R3001M6	0615871H01
C0905M5	2113945C31	R3002M5	0615871H01
C0906M5	2113945A10	R3002M6	0615871H01
C0907M5	2113945L41	R3003M5	0615871H01
C0908M5	21667009166	R3003M6	0615871H01
C0909M5	2113944C02	R3004M5	0615871H01
C0910M5	21667009166	R3004M6	0615871H01
C0911M5	2113944C02	R3005M5	0613952H25

Circuit Ref.	Motorola Solutions Part No.	Circuit Ref.	Motorola Solutions Part No.
C0912M5	21667009166	R3005M6	0613952H25
C0913M5	21667009166	R3006M5	0613952H25
C0916M5	NOT PLACED	R3006M6	0613952H25
C0917M5	21667009166	R3007M5	0613952M30
C0918M5	21667009166	R3007M6	0613952M30
C0919M5	21667009166	R3008M5	0613952G67
C0920M5	2113944C02	R3008M6	0613952G67
C0921M5	2113944C02	R3009M5	0613952M43
C0922M5	2113945C31	R3009M6	0613952M43
C0923M5	2113944C02	R3010M5	0613952G67
C0924M5	21667009166	R3010M6	0613952G67
C0925M5	2113945C31	R3011M5	0613959Q60
C0926M5	2113944C02	R3011M6	0613959Q60
C0927M5	2113944C01	R3012M5	0613959Q60
C0928M5	2113944C51	R3012M6	0613959Q60
C0929M5	2113944C49	R3013M5	0613952R01
C0930M5	NOT PLACED	R3013M6	0613952R01
C0950M5	2113944C47	R3014M5	0613952R01
C0951M5	21667011356	R3014M6	0613952R01
C0952M5	2113944C47	R3015M5	0615871H01
C0953M5	2113944C47	R3015M6	0615871H01
C0954M5	21667011457	R3018M5	0613952H73
C0955M5	2113944C47	R3018M6	0613952H73
C0956M5	2113944C01	R3019M5	0613952H60
C0957M5	2113944C49	R3019M6	0613952H60
C3000M5	2113944C38	R3020M5	0613952G67
C3000M6	2113944C38	R3020M6	0613952G67
C3001M5	2113944C06	R3021M5	0613952R25
C3001M6	2113944C06	R3021M6	0613952R25
C3002M5	2113944C06	RT0900M5	0615585H01
C3002M6	2113944C06	SH0000M2	26012095001
C3003M5	2113945C31	SH0001M2	26012095001
C3003M6	2113945C31	SH0002M2	26012097001
C3004M5	2113945C02	SH0003M2	26012094001
C3004M6	2113945C02	SH0004M2	26012094001

Circuit Ref.	Motorola Solutions Part No.	Circuit Ref.	Motorola Solutions Part No.
C3005M5	2113945C02	SH0200M7	26012095001
C3005M6	2113945C02	SH0300M7	26012095001
C3008M5	2113944C51	SH0400M4	26012096001
C3008M6	2113944C51	SH0401M4	26012096001
C3009M5	2113945C31	SH0402M4	26012098001
C3009M6	2113945C31	SH0403M4	26012098001
C3010M5	2113944C46	SH0500M3	26012098001
C3010M6	2113944C46	SH0501M3	NOT PLACED
C3011M5	NOT PLACED	SH0900M5	2686425Z02
C3011M6	NOT PLACED	SH0901M5	2686425Z02
C3012M5	2113946J04	SH0902M5	26012100001
C3012M6	2113946J04	SP3000M5	NOT PLACED
C3013M5	2113945C31	SP3000M6	NOT PLACED
C3013M6	2113945C31	SP3001M5	NOT PLACED
C3014M5	21009337414	SP3001M6	NOT PLACED
C3014M6	21009337414	T0000M2	25012016001
C3015M5	2113946G01	U0000M2	51009877001
C3015M6	2113946G01	U0001M2	5109731C48
C3016M5	2113945C31	U0002M2	4802197J95
C3016M6	2113945C31	U0200M7	5186310Y39
C3019M5	2113946S35	U0400M4	HZ000490A01
C3019M6	2113946S35	U0500M3	4802197J95
C3020M5	2113945C26	U0901M5	5180390L83
C3020M6	2113945C26	U0902M5	51012221001
C3021M5	2113944C06	U0903M5	5115022H01
C3021M6	2113944C06	U0904M5	5109731C48
C3022M5	2113945A10	U0905M5	5109731C48
C3022M6	2113945A10	U3000M5	5116525H01
C3029M5	NOT PLACED	U3000M6	5116525H01
C3029M6	NOT PLACED	U3001M5	4813973M07
C3038M5	21667009379	U3001M6	4813973M07
C3038M6	21667009379	U3002M5	51012133001
C3041M5	21667009379	U3002M6	51012133001
C3041M6	21667009379	VR0001M2	4815096H01
C3042M5	21667009379	VR0200M7	CR000291A01

Circuit Ref.	Motorola Solutions Part No.	Circuit Ref.	Motorola Solutions Part No.
C3042M6	21667009379	VR0201M7	CR000291A01
C3044M5	21667009379	VR0202M7	CR000291A01
C3044M6	21667009379	VR0203M7	CR000291A01
C3046M5	NOT PLACED	VR0204M7	CR000291A01
C3046M6	NOT PLACED	VR0205M7	CR000291A01
C3047M5	NOT PLACED	VR0206M7	CR000291A01
C3047M6	NOT PLACED	VR0207M7	CR000291A01
C3048M5	NOT PLACED	VR0208M7	CR000291A01
C3048M6	NOT PLACED	VR0209M7	CR000291A01
C3049M5	NOT PLACED	VR0210M7	CR000291A01
C3049M6	NOT PLACED	VR0211M7	CR000291A01
D0000M2	4815011H01	VR0214M7	CR000291A01
D0001M2	4815011H01	VR0215M7	CR000291A01
D0400M4	4884800Y03	VR0400M4	CR000291A01
D0401M4	4813974A19	VR0401M4	CR000291A01
D0402M4	4813974A19	VR0402M4	CR000291A01
D0403M4	4884800Y03	VR0403M4	CR000291A01
D0500M3	4813974A19	VR0404M4	CR000291A01
D0700M5	CR001073A01	VR0405M4	CR000291A01
D0875M5	48012160001	VR0406M4	CR000291A01
D0876M5	4886622Y06	VR0407M4	CR000291A01
D0877M5	48012160001	VR3000M5	48012202001
D0900M5	48012181001	VR3000M6	48012202001
D0950M5	4813974A21	VR3002M5	4813977M10
D0951M5	4813974A21	VR3002M6	4813977M10
D3000M5	4813978P07	Y0000M2	4875185M05



NOTICE: The suffix "M1", "M2", and so on from the Circuit Ref. is removed from the schematic and overlays.

8.6

UHF1 High Power Service Information

8.6.1

Allocation of Schematics and Circuit Boards

This chapter shows the schematics for the UHF1 circuits. The PCB component layouts and the Parts List in this chapter show both the Controller and UHF1 circuit components.

UHF1 Schematic Diagrams and Parts List for 84012737001-A

Diagrams:

- [Figure 200: Main Board Top Side PCB No. 84012737001-A on page 395](#)
- [Figure 201: Main Board Bottom Side PCB No. 84012737001-A on page 396](#)
- [Figure 202: Overall Schematic Diagram on page 397](#)
- [Figure 203: Receiver Front-End Schematic Diagram on page 398](#)
- [Figure 204: Receiver IF Amp Schematic Diagram on page 399](#)
- [Figure 205: Transmitter Power Amplifier Schematic Diagram on page 400](#)
- [Figure 206: Power Control Schematic Diagram on page 401](#)
- [Figure 207: Transmitter Power Amplifier DC Distribution Schematic Diagram on page 402](#)
- [Figure 208: RFIC Schematic Diagram on page 403](#)
- [Figure 209: Receiver VCO Schematic Diagram on page 404](#)
- [Figure 210: Transmit VCO Schematic Diagram on page 405](#)
- [Figure 211: VCO Buffer Schematic Diagram on page 406](#)

[Parts List for 84012737001-A on page 407](#)

UHF1 Schematic Diagrams and Parts List for 84012737003-C

Diagrams:

- [Figure 212: Main Board Top Side PCB No. 84012737003-C on page 433](#)
- [Figure 213: Main Board Bottom Side PCB No. 84012737003-C on page 434](#)
- [Figure 214: Overall Schematic Diagram on page 435](#)
- [Figure 215: Receiver Front-End Schematic Diagram on page 436](#)
- [Figure 216: Receiver IF Amp Schematic Diagram on page 437](#)
- [Figure 217: Transmitter Power Amplifier Schematic Diagram on page 438](#)
- [Figure 218: Power Control Schematic Diagram on page 439](#)
- [Figure 219: Transmitter Power Amplifier DC Distribution Schematic Diagram on page 440](#)
- [Figure 220: RFIC Schematic Diagram on page 441](#)
- [Figure 221: Receiver VCO Schematic Diagram on page 442](#)
- [Figure 222: Transmit VCO Schematic Diagram on page 443](#)
- [Figure 223: VCO Buffer Schematic Diagram on page 444](#)

[Parts List for 84012737003-C on page 445](#)

8.6.1.1

Circuit Board and Schematic Diagrams for 84012737001-A

Figure 200: Main Board Top Side PCB No. 84012737001-A

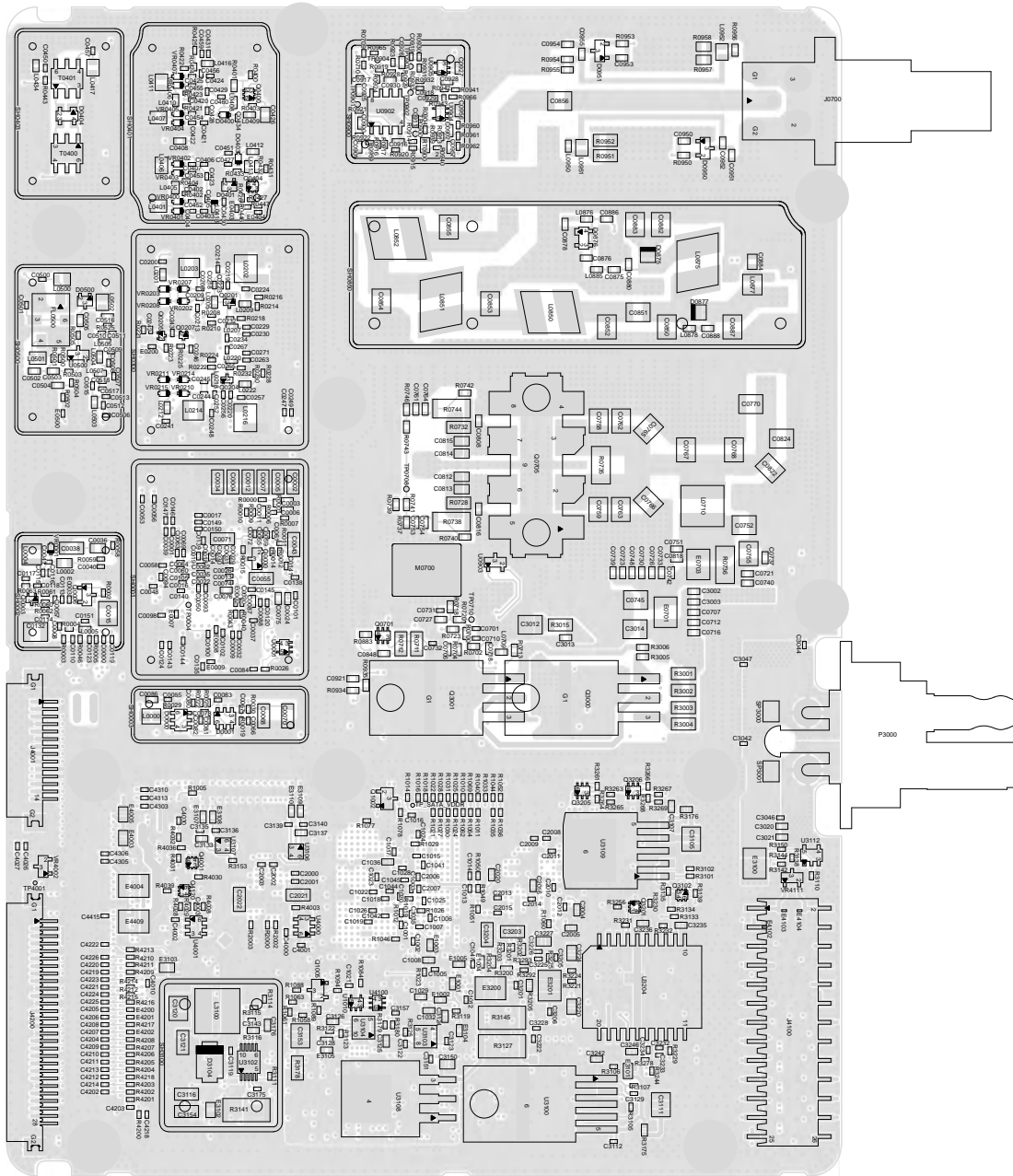

Figure 204: Receiver IF Amp Schematic Diagram

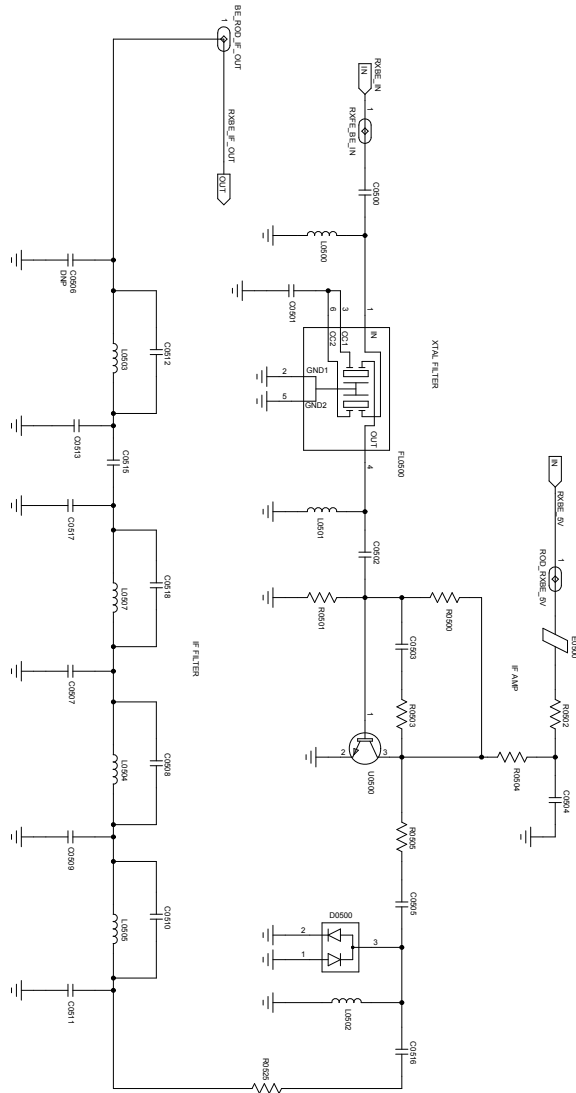
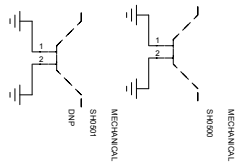

Figure 205: Transmitter Power Amplifier Schematic Diagram

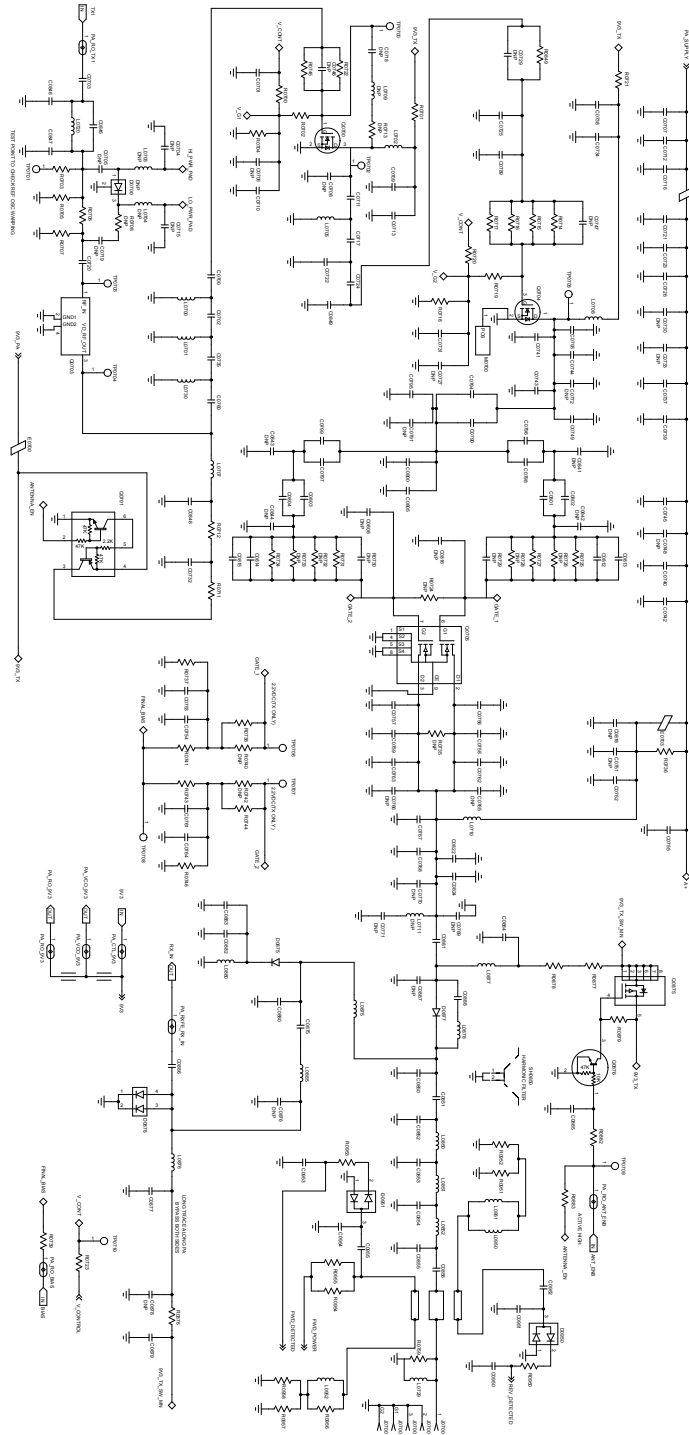

Figure 206: Power Control Schematic Diagram

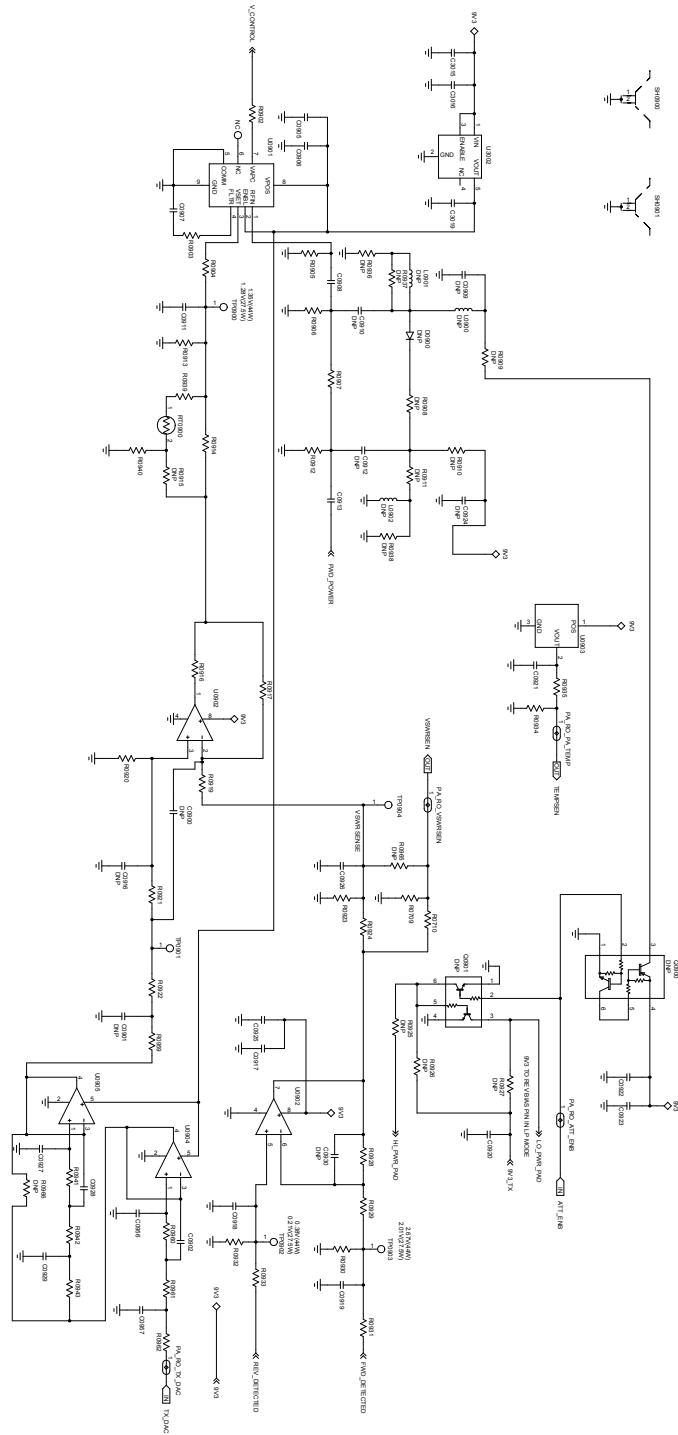

Figure 207: Transmitter Power Amplifier DC Distribution Schematic Diagram

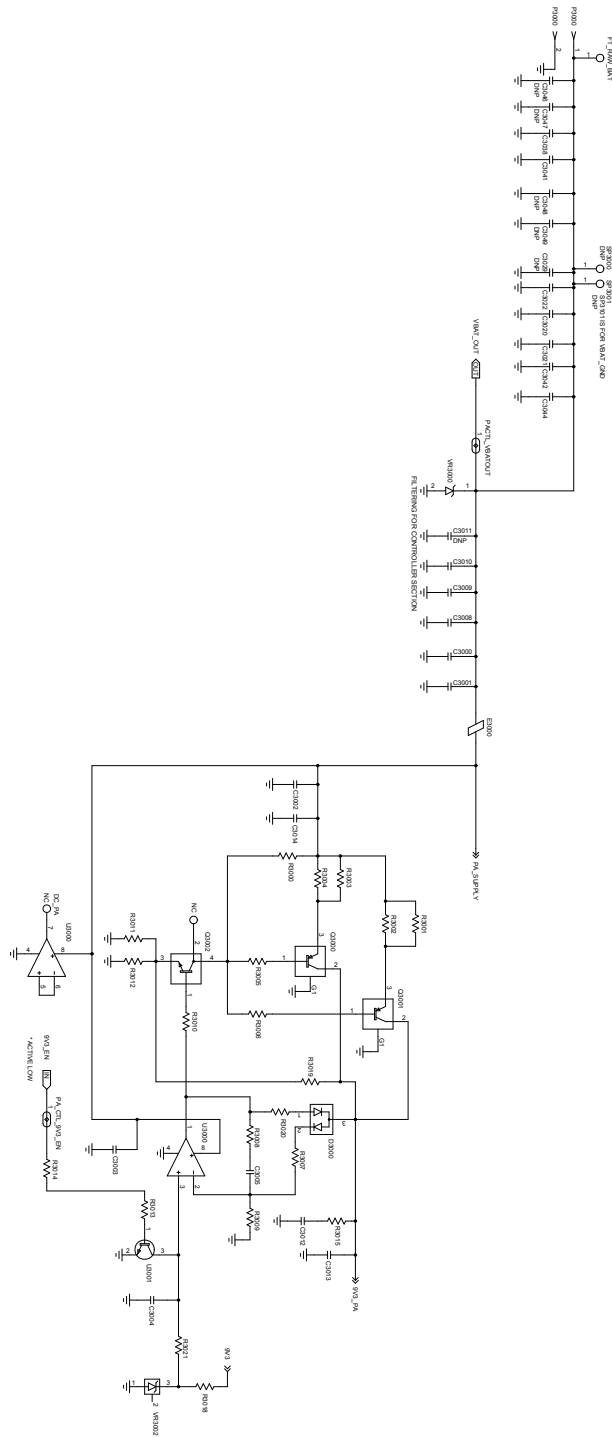

Figure 208: RFIC Schematic Diagram

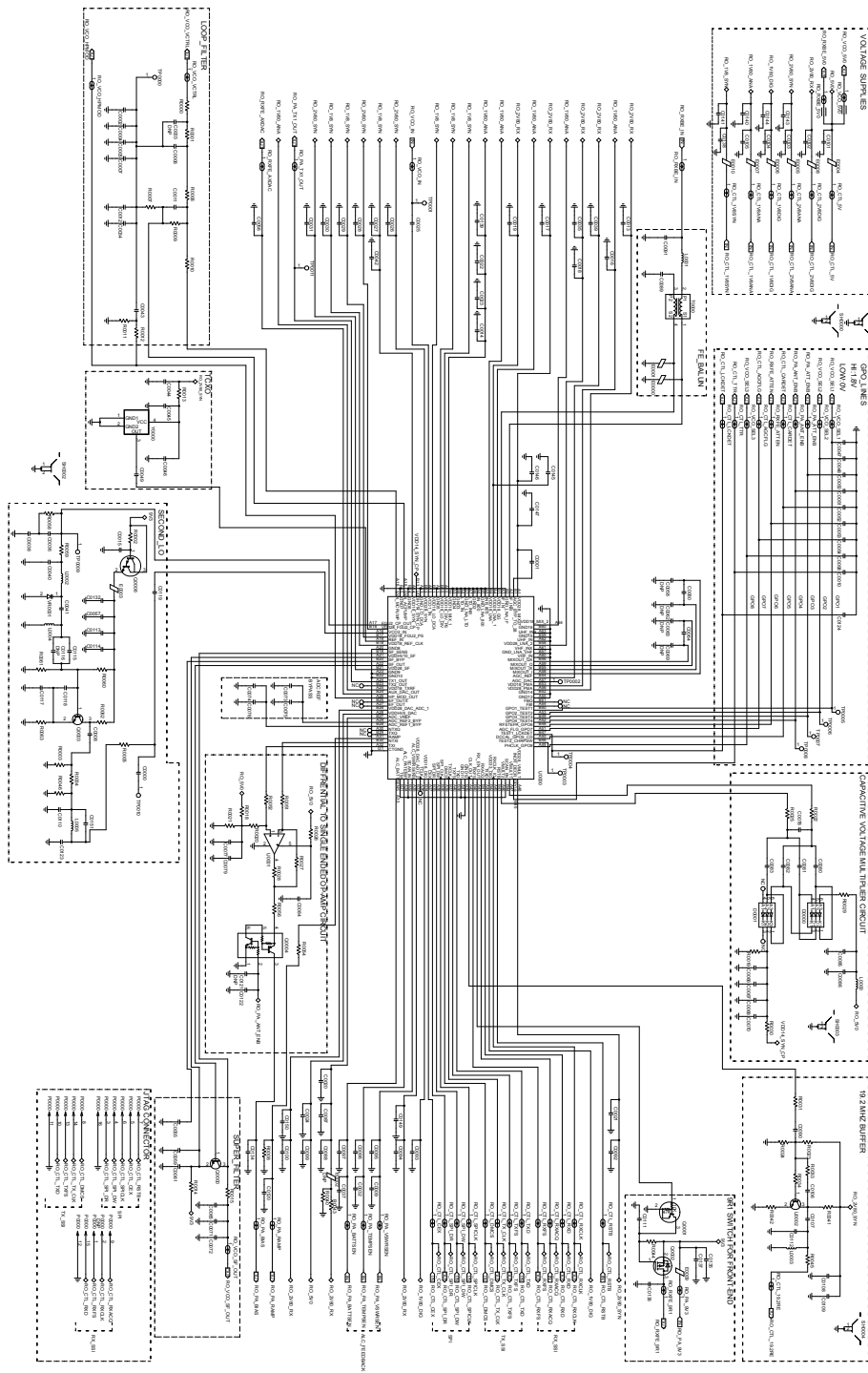

Figure 209: Receiver VCO Schematic Diagram

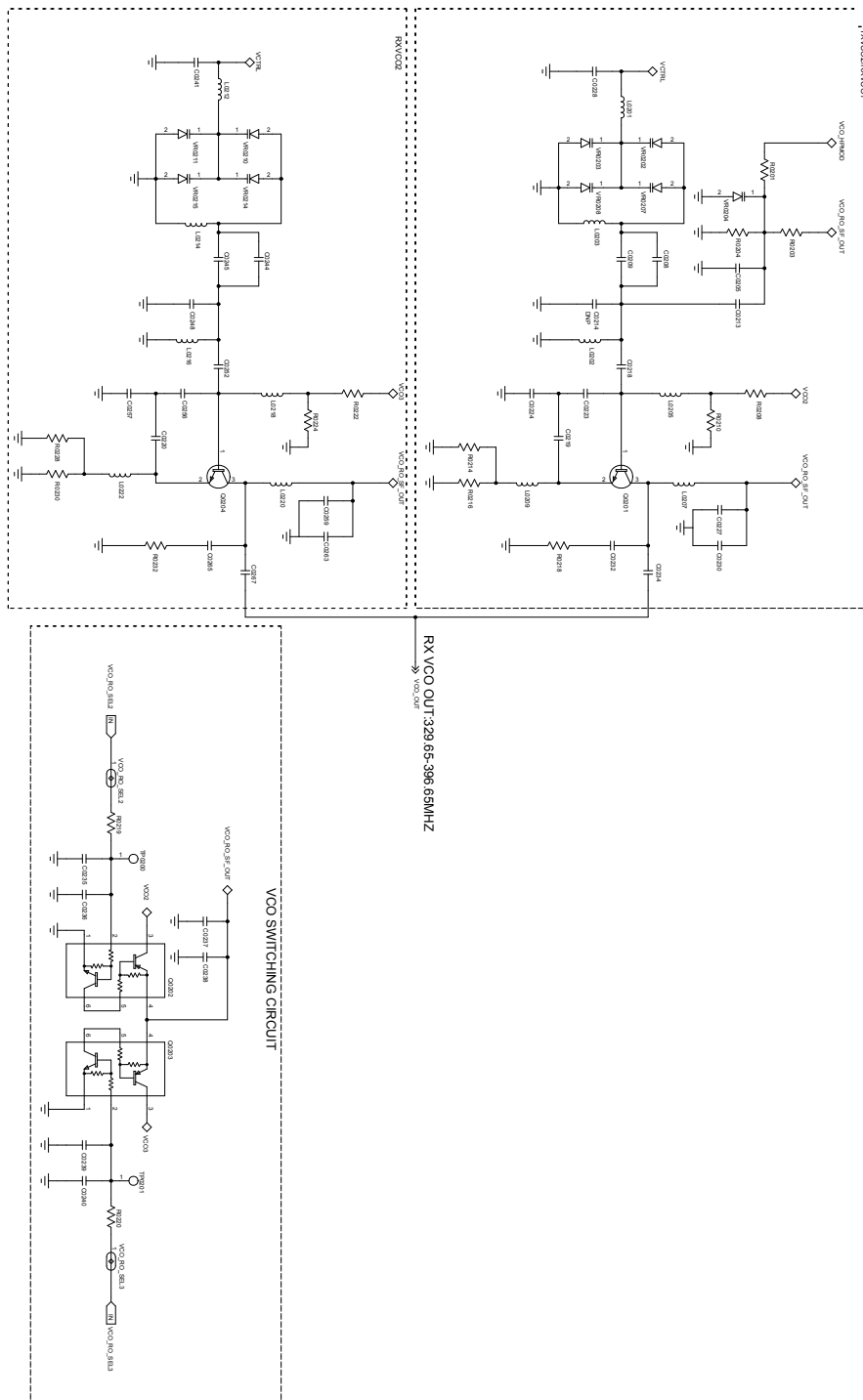

Figure 210: Transmit VCO Schematic Diagram

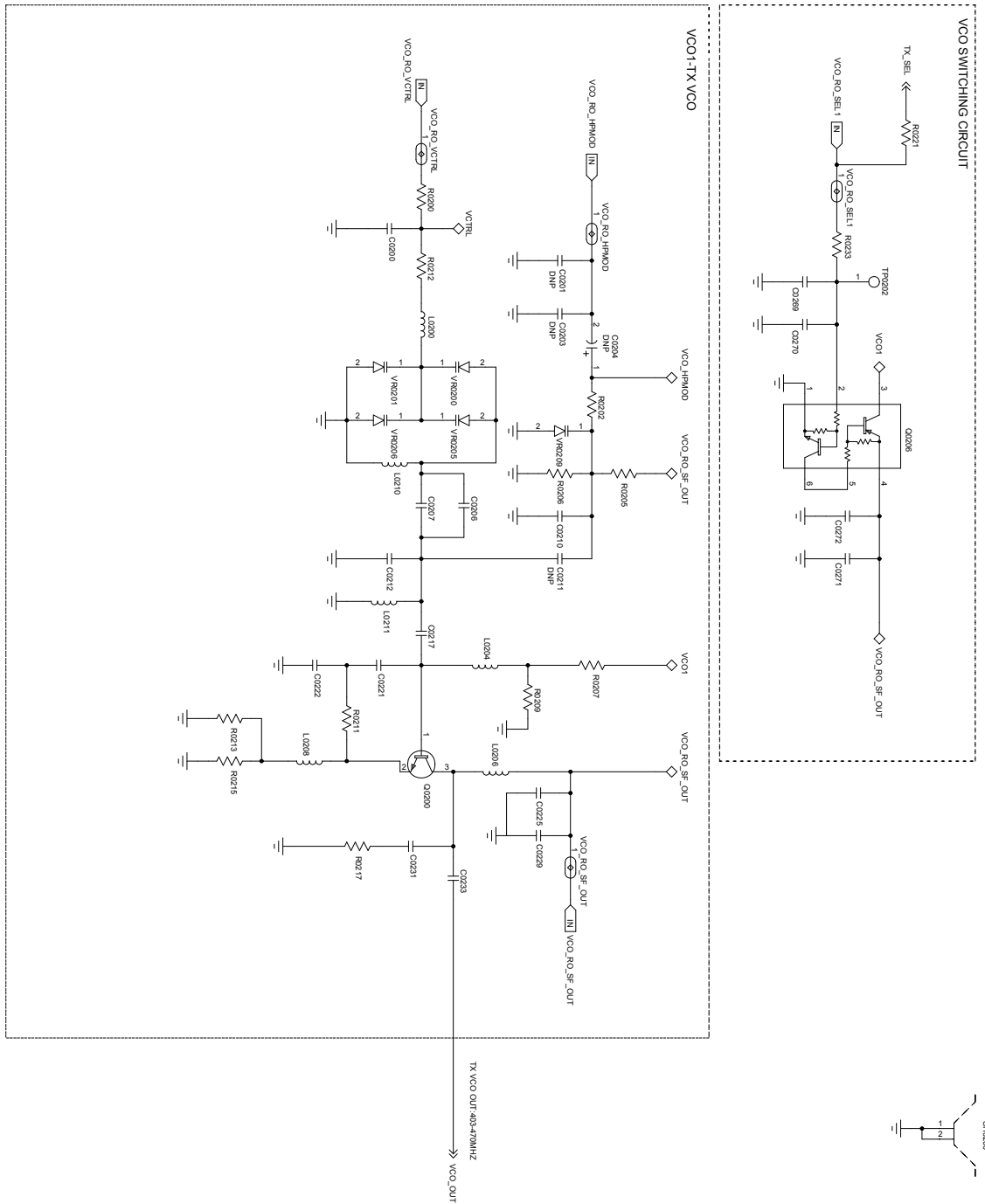
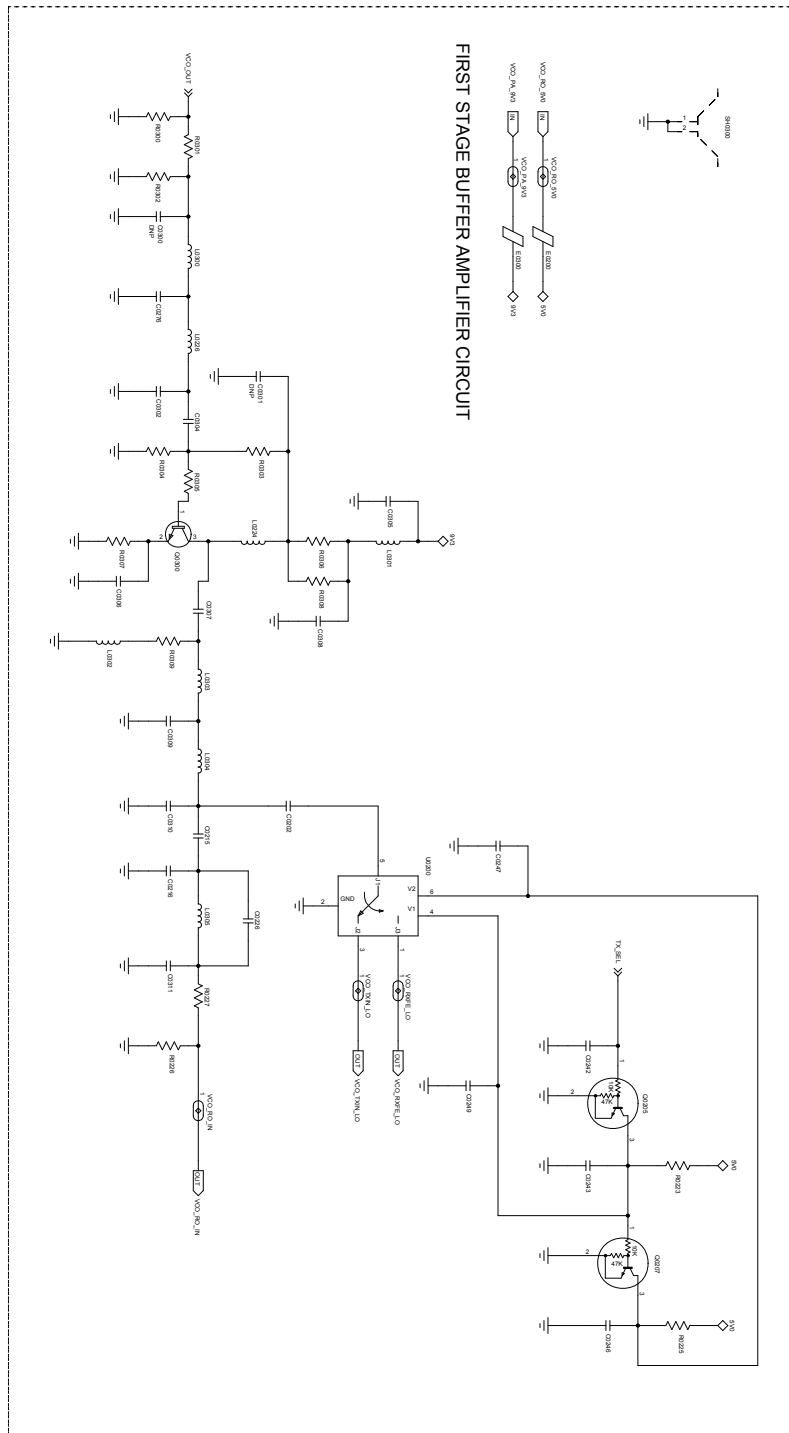

Figure 211: VCO Buffer Schematic Diagram



8.6.1.2

Parts List for 84012737001-A

Table 23: UHF1 Radio Parts List

Circuit Ref.	Motorola Solutions Part No.	Circuit Ref.	Motorola Solutions Part No.
C0000M2	21667009311	L0408M4	24667008030
C0001M2	21667009170	L0409M4	24667008030
C0002M2	21012044001	L0410M4	24667008025
C0003M2	NOT PLACED	L0411M4	24012021001
C0004M2	21012044001	L0412M4	24667008030
C0005M2	21012044001	L0413M4	24667008030
C0006M2	2113945C31	L0414M4	24009344106
C0007M2	21012044001	L0415M4	24009344108
C0008M2	21667009311	L0416M4	24667008017
C0009M2	21667009166	L0417M4	24009344110
C0010M2	21667009166	L0418M4	NOT PLACED
C0011M2	2113945C31	L0421M4	24009344106
C0012M2	21012044001	L0424M4	24009344106
C0013M2	2113945Y02	L0428M4	24009344106
C0014M2	2113945Y02	L0434M4	24667008021
C0015M2	2113946J03	L0500M3	24009344127
C0016M2	2113945A10	L0501M3	24009344128
C0017M2	2113945Y02	L0502M3	24009344126
C0018M2	2113945A10	L0503M3	24667008021
C0019M2	2113945Y02	L0504M3	24667008026
C0020M2	2113945A10	L0505M3	24667008026
C0021M2	2113945Y02	L0507M3	24667008024
C0022M2	2113945Y02	L0700M6	24667008011
C0023M2	2113945Y02	L0701M6	24667008012
C0024M2	21012102001	L0702M6	24667008028
C0025M2	21667009166	L0703M6	NOT PLACED
C0026M2	21667009174	L0704M6	NOT PLACED
C0027M2	2113945Y02	L0705M6	24667008007
C0028M2	2113945Y02	L0707M6	24667008028
C0029M2	2113945A10	L0708M6	2479990G01
C0030M2	2113945A10	L0709M6	NOT PLACED
C0031M2	2113945Y02	L0710M6	2485873L01

Circuit Ref.	Motorola Solutions Part No.	Circuit Ref.	Motorola Solutions Part No.
C0032M2	21667009166	L0711M6	NOT PLACED
C0034M2	21012044001	L0720M6	24667008014
C0035M2	21667009166	L0729M6	2414032B60
C0036M2	21012025001	L0730M6	24667008012
C0037M2	21667009166	L0850M6	2460592A01
C0038M2	21012044001	L0851M6	2460592A01
C0039M2	2113945Y02	L0852M6	2460592A01
C0040M2	2113945A10	L0875M6	2460592A01
C0041M2	21667009364	L0876M6	24667008029
C0042M2	21667009166	L0877M6	2414032B49
C0043M2	21012044001	L0878M6	24667008024
C0044M2	2113955D45	L0880M6	2414032B49
C0045M2	2113945Y02	L0885M6	24667008014
C0046M2	21667009166	L0900M6	NOT PLACED
C0047M2	21667009166	L0901M6	NOT PLACED
C0048M2	21667009166	L0902M6	NOT PLACED
C0049M2	2113945B02	L0950M6	24667008022
C0050M2	21667009166	L0951M6	24009344022
C0051M2	21667009166	L0952M6	24009344006
C0052M2	21667009166	L3100M1	24012091002
C0053M2	21667009166	M0700M6	2686201B02
C0054M2	21667009166	P0000M2	NOT PLACED
C0055M2	2113955D37	P1000M1	2887818K02
C0056M2	2113945Y02	P3000M6	09009344001
C0057M2	2113945B02	Q0000M2	4813973A13
C0058M2	NOT PLACED	Q0001M2	48009494001
C0059M2	21667009166	Q0002M2	4813970A59
C0060M2	2113945A69	Q0003M2	48012195001
C0061M2	2113945Y02	Q0004M2	4815272H01
C0062M2	NOT PLACED	Q0006M2	4813973A04
C0063M2	NOT PLACED	Q0200M7	48012195001
C0064M2	2113945A69	Q0201M7	48012195001
C0065M2	2113945Y02	Q0202M7	4815272H01
C0066M2	2113945B02	Q0203M7	4815272H01
C0067M2	2113945Y02	Q0204M7	48012195001

Circuit Ref.	Motorola Solutions Part No.	Circuit Ref.	Motorola Solutions Part No.
C0068M2	2113955D37	Q0205M7	48009494001
C0069M2	NOT PLACED	Q0206M7	4815272H01
C0070M2	2113955D37	Q0207M7	48009494001
C0071M2	2113955D37	Q0300M7	4802197J95
C0072M2	21667009166	Q0400M4	4815271H01
C0073M2	21667009166	Q0401M4	4815267H01
C0074M2	21667009166	Q0402M4	4815118H01
C0075M2	2113946S35	Q0403M4	4815270H01
C0076M2	2113946S35	Q0404M4	4815271H01
C0077M2	21667009166	Q0405M4	4815118H01
C0078M2	21667009372	Q0700M6	4816547H01
C0079M2	2113955D37	Q0701M6	4816013H01
C0080M2	2113945B02	Q0703M6	4802246J29
C0081M2	2113945B02	Q0704M6	4816548H01
C0082M2	2113945B02	Q0705M6	48012022001
C0083M2	2113945B02	Q0875M6	4813970A62
C0084M2	21667009166	Q0876M6	48009494001
C0085M2	21667009166	Q0900M6	NOT PLACED
C0086M2	2113945C31	Q0901M6	NOT PLACED
C0087M2	2113946S35	Q1000M1	4815263H01
C0088M2	2113945Y02	Q1001M1	4815272H01
C0089M2	2113945Y02	Q1002M1	4815261H01
C0090M2	2113945B02	Q1004M1	4815261H01
C0091M2	2113944C82	Q1005M1	4815261H01
C0092M2	21667009166	Q3000M6	0105959T72
C0093M2	2113945Y02	Q3001M6	0105959T72
C0094M2	2113945Y02	Q3002M6	4813973B01
C0095M2	2113945A13	Q3100M1	4815272H01
C0096M2	2113945B02	Q3101M1	4809939C47
C0097M2	2113945B02	Q3102M1	4809939C47
C0098M2	21667009166	Q3103M1	48009494001
C0099M2	2113945Y02	Q3105M1	4809939C47
C0100M2	2113945Y02	Q3160M1	48009494001
C0101M2	21667009166	Q3161M1	4815272H01
C0102M2	21667009166	Q3162M1	4813973M07

Circuit Ref.	Motorola Solutions Part No.	Circuit Ref.	Motorola Solutions Part No.
C0103M2	21667009166	Q3163M1	48009494001
C0104M2	21667009166	Q3200M1	4815270H01
C0105M2	21667009166	Q3201M1	4815272H01
C0106M2	2113945B02	Q3202M1	4815270H01
C0107M2	2113945B02	Q3203M1	4815270H01
C0108M2	21667009166	Q3204M1	4815270H01
C0109M2	2113945Y02	Q3205M1	4815270H01
C0110M2	21667009381	Q3206M1	4815270H01
C0111M2	2113945Y02	Q3207M1	4815270H01
C0112M2	21667009166	Q3208M1	4815263H01
C0113M2	21667009166	Q4000M1	4809939C47
C0114M2	2113945Y02	Q4001M1	4809939C47
C0115M2	21667009370	Q4002M1	4809939C47
C0116M2	NOT PLACED	Q4100M1	4816023H01
C0117M2	21667009374	Q4101M1	4815261H01
C0118M2	21667009375	Q4102M1	4815263H01
C0119M2	2113945A10	Q4103M1	48012271001
C0120M2	21667009166	Q4105M1	48012271001
C0121M2	NOT PLACED	Q4106M1	48012271001
C0122M2	21667009166	Q4109M1	48012271001
C0123M2	21667009381	Q4112M1	48012271001
C0124M2	21667009166	Q4120M1	4809939C47
C0132M2	2113946J03	R0000M2	0613952R66
C0134M2	21667009166	R0001M2	0613952R66
C0135M2	21667009166	R0002M2	0613952Q96
C0136M2	21667009166	R0003M2	0613952Q57
C0137M2	2113945Y02	R0004M2	0613952Q34
C0138M2	21667009166	R0005M2	0613952R66
C0139M2	21667009166	R0006M2	0613952Q25
C0140M2	2113945Y02	R0007M2	0613952Q51
C0141M2	2113945Y02	R0008M2	0613952R01
C0143M2	2113945Y02	R0009M2	0613952Q58
C0144M2	2113945Y02	R0010M2	0613952R66
C0145M2	21667009166	R0011M2	0613952Q36
C0146M2	2113945A10	R0012M2	0613952Q86

Circuit Ref.	Motorola Solutions Part No.	Circuit Ref.	Motorola Solutions Part No.
C0147M2	2113945A10	R0013M2	0613952Q35
C0149M2	21667009166	R0014M2	0613952R66
C0150M2	21667009166	R0015M2	0613952R66
C0151M2	21667009368	R0018M2	0613952Q80
C0200M7	21667009166	R0019M2	0613952R01
C0201M7	NOT PLACED	R0020M2	0613952R12
C0202M7	21667009166	R0021M2	0613952Q80
C0203M7	NOT PLACED	R0022M2	0613952R66
C0204M7	NOT PLACED	R0023M2	0613952Q83
C0205M7	21667009274	R0024M2	0613952Q80
C0206M7	21667009366	R0025M2	0613952R66
C0207M7	21667009365	R0026M2	0613952R66
C0208M7	21667009311	R0027M2	0613952R12
C0209M7	21667009311	R0028M2	0613952R66
C0210M7	21667009274	R0029M2	0613952Q25
C0211M7	NOT PLACED	R0030M2	0613952R66
C0212M7	21667009294	R0031M2	0613952R66
C0213M7	21667009274	R0033M2	0613952R01
C0214M7	NOT PLACED	R0034M2	0613952Q57
C0215M7	21667009315	R0040M2	0613952Q70
C0216M7	21667009311	R0041M2	0613952Q58
C0217M7	21667009346	R0042M2	0613952Q42
C0218M7	21667009339	R0043M2	0613952Q73
C0219M7	21667009378	R0044M2	0613952R25
C0220M7	21667009380	R0045M2	0613952R66
C0221M7	21667009371	R0046M2	0613952Q57
C0222M7	21667009366	R0051M2	0613952R01
C0223M7	21667009370	R0052M2	0613952R01
C0224M7	21667009369	R0054M2	0613952M25
C0225M7	2113945Y02	R0056M2	0613952R66
C0226M7	21667009311	R0058M2	0613952Q74
C0227M7	2113945Y02	R0059M2	0613952R66
C0228M7	21667009166	R0060M2	0613952Q89
C0229M7	21667009166	R0061M2	0613952Q85
C0230M7	21667009166	R0062M2	0613952Q61

Circuit Ref.	Motorola Solutions Part No.	Circuit Ref.	Motorola Solutions Part No.
C0231M7	21667009166	R0063M2	0613952Q64
C0232M7	21667009166	R0200M7	0613952R66
C0233M7	21667009284	R0201M7	0613952R27
C0234M7	21667009315	R0202M7	0613952R27
C0235M7	21667009166	R0203M7	0613952R07
C0236M7	2113945Y02	R0204M7	0613952R05
C0237M7	21667009166	R0205M7	0613952R07
C0238M7	2113945Y02	R0206M7	0613952R05
C0239M7	2113945Y02	R0207M7	0613952Q84
C0240M7	21667009166	R0208M7	0613952Q87
C0241M7	21667009166	R0209M7	0613952Q85
C0242M7	21667009166	R0210M7	0613952Q79
C0243M7	21667009166	R0211M7	0613952Q18
C0244M7	21667009332	R0212M7	0613952Q32
C0245M7	21667009332	R0213M7	0613952Q67
C0246M7	21667009166	R0214M7	0613952Q67
C0247M7	21667009166	R0215M7	0613952Q67
C0248M7	21667009326	R0216M7	0613952Q67
C0249M7	21667009166	R0217M7	0613952Q49
C0252M7	21667009326	R0218M7	0613952Q49
C0256M7	21667009371	R0219M7	0613952R66
C0257M7	21667009366	R0220M7	0613952R66
C0259M7	2113945Y02	R0221M7	0613952R66
C0263M7	21667009166	R0222M7	0613952Q79
C0265M7	21667009166	R0223M7	0613952Q73
C0267M7	21667009297	R0224M7	0613952Q78
C0269M7	21667009166	R0225M7	0613952Q73
C0270M7	2113945Y02	R0226M7	0613952Q29
C0271M7	21667009166	R0227M7	0613952G67
C0272M7	2113945Y02	R0228M7	0613952Q67
C0276M7	21667009311	R0230M7	0613952Q67
C0300M7	NOT PLACED	R0232M7	0613952Q49
C0301M7	NOT PLACED	R0233M7	0613952R66
C0302M7	21667009286	R0300M7	0613952Q66
C0304M7	21667009390	R0301M7	0613952Q25

Circuit Ref.	Motorola Solutions Part No.	Circuit Ref.	Motorola Solutions Part No.
C0305M7	2113945Y02	R0302M7	0613952Q66
C0306M7	2113945B02	R0303M7	0613952R05
C0307M7	21667009390	R0304M7	0613952Q89
C0308M7	2113945B02	R0305M7	0613952Q33
C0309M7	21667009280	R0306M7	0613952Q32
C0310M7	21667009279	R0307M7	0613952Q49
C0311M7	21667009346	R0308M7	0613952Q32
C0400M4	21667009274	R0309M7	0613952Q42
C0402M4	21667009166	R0400M4	0613952R01
C0403M4	21667009297	R0401M4	0613952H81
C0404M4	21667009368	R0402M4	0613952R25
C0405M4	21667009284	R0403M4	0613952R01
C0406M4	21667009297	R0404M4	0613952R25
C0407M4	21667009368	R0405M4	0613952R05
C0408M4	2113945C31	R0406M4	0613952Q91
C0409M4	2113945C31	R0407M4	0613952Q91
C0410M4	21667009166	R0408M4	0613952Q75
C0411M4	21667009376	R0409M4	0613952Q69
C0412M4	2113946F05	R0410M4	0613952R01
C0413M4	21667009166	R0411M4	0613952R01
C0414M4	21667009166	R0412M4	0613952Q83
C0415M4	21667009370	R0413M4	0613958H55
C0416M4	2113945C31	R0414M4	0613958H55
C0417M4	21667009166	R0415M4	0613952Q57
C0418M4	21667009166	R0416M4	0613952Q69
C0419M4	21667009274	R0417M4	0613952Q69
C0420M4	21667009166	R0418M4	0613952Q69
C0421M4	21667009297	R0419M4	0613952Q69
C0422M4	21667009368	R0420M4	0613952R25
C0423M4	21667009280	R0421M4	0613952R25
C0424M4	21667009297	R0422M4	0613952Q67
C0425M4	21667009368	R0423M4	0613952R25
C0426M4	2113946F05	R0424M4	0613952Q23
C0427M4	21667009372	R0425M4	0613952Q67
C0428M4	21667009284	R0426M4	0613952Q87

Circuit Ref.	Motorola Solutions Part No.	Circuit Ref.	Motorola Solutions Part No.
C0429M4	21667009280	R0427M4	0613952Q93
C0430M4	21667009161	R0429M4	0613952R66
C0431M4	21667009368	R0430M4	NOT PLACED
C0433M4	21667009166	R0431M4	0613952R01
C0434M4	21667009384	R0432M4	0613952H73
C0435M4	21667009380	R0433M4	0613952R01
C0436M4	21667009166	R0434M4	0613952L46
C0437M4	2113945C31	R0435M4	0613952L46
C0438M4	21667009166	R0436M4	0613952R66
C0439M4	21667009346	R0437M4	0613952Q77
C0440M4	21667009315	R0438M4	0613958H25
C0441M4	21667009372	R0439M4	0613952Q83
C0442M4	21667009277	R0440M4	0613958H25
C0443M4	21667009364	R0441M4	0613958H49
C0444M4	21667009286	R0442M4	0613952Q83
C0445M4	21667009368	R0443M4	0613952Q25
C0446M4	21667009355	R0444M4	0613952K25
C0447M4	21667009277	R0445M4	0613952Q75
C0448M4	21667009372	R0446M4	NOT PLACED
C0449M4	21667009315	R0447M4	0613952R66
C0450M4	21667009388	R0448M4	0613952Q25
C0451M4	21667009166	R0500M3	0613952Q87
C0452M4	21667009366	R0501M3	0613952R19
C0453M4	21667009366	R0502M3	0613952Q66
C0454M4	21667009366	R0503M3	0613952Q88
C0455M4	21667009366	R0504M3	0613952Q61
C0456M4	21667009355	R0505M3	0613952R66
C0457M4	21667009307	R0525M3	0613952R66
C0458M4	2113946F05	R0700M6	0613952J05
C0459M4	21667009307	R0701M6	0613952G67
C0460M4	21667009166	R0702M6	0613952H89
C0461M4	NOT PLACED	R0703M6	0613952J01
C0462M4	21667009159	R0704M6	0613952J06
C0463M4	NOT PLACED	R0705M6	0613952H48
C0464M4	21667009158	R0706M6	0613952H45

Circuit Ref.	Motorola Solutions Part No.	Circuit Ref.	Motorola Solutions Part No.
C0465M4	21667009166	R0707M6	0613952H48
C0468M4	21667009166	R0708M6	NOT PLACED
C0469M4	21667009166	R0709M6	0613952N43
C0500M3	21667009369	R0710M6	0613952P01
C0501M3	21667009332	R0711M6	0613958S44
C0502M3	2113944M21	R0712M6	0613958S44
C0503M3	2113945C31	R0713M6	NOT PLACED
C0504M3	2113945C31	R0714M6	0613958H15
C0505M3	21667011351	R0715M6	0613958H15
C0506M3	NOT PLACED	R0716M6	0613958H15
C0507M3	21667009374	R0717M6	0613958H15
C0508M3	21667009366	R0718M6	0613952H96
C0509M3	21667009382	R0719M6	0613952H89
C0510M3	21667009366	R0720M6	0613952H95
C0511M3	21667009355	R0721M6	0613952G67
C0512M3	21667009303	R0722M6	0613952H29
C0513M3	21667009368	R0723M6	0613952G67
C0515M3	21667009383	R0724M6	NOT PLACED
C0516M3	21667011464	R0725M6	0613958S29
C0517M3	21667009315	R0726M6	NOT PLACED
C0518M3	21667009339	R0727M6	0613958S29
C0700M6	2113944C45	R0728M6	NOT PLACED
C0701M6	21667009163	R0729M6	NOT PLACED
C0702M6	2113944C41	R0730M6	NOT PLACED
C0703M6	2113944C42	R0731M6	0613958S29
C0704M6	NOT PLACED	R0732M6	NOT PLACED
C0705M6	NOT PLACED	R0733M6	NOT PLACED
C0706M6	NOT PLACED	R0734M6	0613958S29
C0707M6	2113944C82	R0735M6	NOT PLACED
C0708M6	NOT PLACED	R0736M6	0613959Q25
C0709M6	2113945C04	R0737M6	0613952F01
C0710M6	21667009163	R0738M6	0613959Q32
C0711M6	2113944C46	R0739M6	0613952H73
C0712M6	2113945C04	R0740M6	NOT PLACED
C0713M6	21667009163	R0741M6	0613952E66

Circuit Ref.	Motorola Solutions Part No.	Circuit Ref.	Motorola Solutions Part No.
C0715M6	NOT PLACED	R0742M6	NOT PLACED
C0716M6	2113944C55	R0743M6	0613952E66
C0717M6	2113944C39	R0744M6	0613959Q32
C0718M6	NOT PLACED	R0745M6	0613952H29
C0719M6	NOT PLACED	R0746M6	0613952F01
C0720M6	2113944C42	R0759M6	0613959H12
C0721M6	2113944C82	R0849M6	0613952G67
C0722M6	2113944C34	R0876M6	0613958S73
C0723M6	2113945C04	R0877M6	0613959Y37
C0724M6	2113944C39	R0878M6	0613959Y37
C0725M6	2113944C39	R0879M6	0613952J25
C0726M6	2113944C51	R0882M6	0613952G67
C0727M6	NOT PLACED	R0883M6	0613952G67
C0729M6	NOT PLACED	R0902M6	0613952R66
C0730M6	NOT PLACED	R0903M6	0613952N01
C0731M6	21667009163	R0904M6	0613952R66
C0732M6	2113945A09	R0905M6	0613952H42
C0733M6	NOT PLACED	R0906M6	0613958H46
C0734M6	2113945A09	R0907M6	0613958H55
C0735M6	21667011073	R0908M6	NOT PLACED
C0737M6	2113944C51	R0909M6	NOT PLACED
C0738M6	21667009163	R0910M6	NOT PLACED
C0739M6	2113945C31	R0911M6	NOT PLACED
C0740M6	2113944C51	R0912M6	0613958H46
C0741M6	21667007037	R0913M6	0613952M51
C0742M6	2113945L49	R0914M6	0613952M71
C0743M6	21667007036	R0915M6	NOT PLACED
C0744M6	21667007037	R0916M6	0613952R66
C0745M6	2113946J04	R0917M6	0613952P01
C0746M6	NOT PLACED	R0919M6	0613952P01
C0747M6	NOT PLACED	R0920M6	0613952N01
C0748M6	NOT PLACED	R0921M6	0613952N01
C0749M6	21667007037	R0922M6	0613952R66
C0751M6	NOT PLACED	R0923M6	0613952M42
C0752M6	2111078B42	R0924M6	0613952N01

Circuit Ref.	Motorola Solutions Part No.	Circuit Ref.	Motorola Solutions Part No.
C0753M6	2113944C51	R0925M6	NOT PLACED
C0754M6	2113944C45	R0926M6	NOT PLACED
C0755M6	2111078B42	R0927M6	NOT PLACED
C0756M6	2111078B22	R0928M6	0613952N81
C0757M6	2111078B22	R0929M6	0613952N85
C0758M6	2111078B27	R0930M6	0613952N42
C0759M6	2111078B27	R0931M6	0613952M66
C0760M6	2113944C45	R0932M6	0613952N30
C0761M6	2113944C45	R0933M6	0613952N01
C0762M6	2111078B26	R0934M6	0613952J17
C0763M6	2111078B26	R0935M6	0613952H91
C0764M6	2113944C51	R0936M6	NOT PLACED
C0765M6	NOT PLACED	R0937M6	NOT PLACED
C0766M6	NOT PLACED	R0938M6	NOT PLACED
C0767M6	2111078B06	R0939M6	0613952Z76
C0768M6	2111078B07	R0940M6	0613952R66
C0769M6	NOT PLACED	R0941M6	0613952N58
C0770M6	NOT PLACED	R0942M6	0613952N58
C0771M6	NOT PLACED	R0943M6	0613952N58
C0772M6	NOT PLACED	R0950M6	0613952G67
C0789M6	2113944C39	R0951M6	0613958M18
C0790M6	21667007032	R0952M6	0613958M18
C0791M6	NOT PLACED	R0953M6	0613952G67
C0793M6	21667007019	R0954M6	0613952H56
C0794M6	21667007032	R0955M6	0613952H56
C0795M6	21667007018	R0956M6	0613952H67
C0796M6	2113944F07	R0957M6	0613958C25
C0797M6	2113944F07	R0958M6	0613958C25
C0798M6	2113944F07	R0959M6	0613952R66
C0799M6	2113944F07	R0960M6	0613952N58
C0800M6	21667007033	R0961M6	0613952N58
C0801M6	2113944F07	R0962M6	0613952N58
C0802M6	2113944F07	R0965M6	NOT PLACED
C0803M6	2113944F07	R0966M6	NOT PLACED
C0804M6	2113944F07	R1000M1	0613952R66

Circuit Ref.	Motorola Solutions Part No.	Circuit Ref.	Motorola Solutions Part No.
C0805M6	21667007033	R1001M1	0613952M66
C0808M6	NOT PLACED	R1002M1	0613952R66
C0812M6	21667007046	R1003M1	0613952R66
C0813M6	21667007046	R1004M1	0613952R66
C0814M6	21667007046	R1005M1	0613952M66
C0815M6	21667007046	R1007M1	0613952R66
C0816M6	NOT PLACED	R1008M1	0613952R66
C0818M6	NOT PLACED	R1009M1	0613952R66
C0822M6	2111078B11	R1010M1	NOT PLACED
C0824M6	2111078B17	R1011M1	NOT PLACED
C0841M6	NOT PLACED	R1012M1	0613952R66
C0842M6	NOT PLACED	R1013M1	0613952M66
C0843M6	NOT PLACED	R1014M1	NOT PLACED
C0844M6	NOT PLACED	R1016M1	NOT PLACED
C0845M6	21667011411	R1018M1	NOT PLACED
C0846M6	21667011059	R1019M1	0613952R66
C0847M6	21667011059	R1020M1	0613952M66
C0848M6	2113944C45	R1021M1	0613952Q73
C0849M6	2113944C39	R1022M1	NOT PLACED
C0850M6	2111078B05	R1023M1	0613952R66
C0851M6	2111078B21	R1024M1	NOT PLACED
C0852M6	2111078B08	R1025M1	0613952Q73
C0853M6	2111078B16	R1026M1	0613952R66
C0854M6	2111078B15	R1027M1	NOT PLACED
C0855M6	2111078B08	R1028M1	0613952R66
C0856M6	2111078B42	R1029M1	0613952R66
C0875M6	2113944C42	R1030M1	NOT PLACED
C0876M6	NOT PLACED	R1031M1	0613952R66
C0877M6	2113944C42	R1033M1	0613952Q73
C0878M6	NOT PLACED	R1034M1	0613952R17
C0879M6	2113944C42	R1035M1	NOT PLACED
C0880M6	21667011073	R1036M1	0613952M66
C0881M6	2111078B42	R1037M1	0613952M66
C0882M6	2111078B22	R1038M1	0613952R66
C0883M6	2111078B34	R1039M1	0613952R66

Circuit Ref.	Motorola Solutions Part No.	Circuit Ref.	Motorola Solutions Part No.
C0884M6	2113944F05	R1040M1	0613952M66
C0885M6	2113944C51	R1041M1	0613952R66
C0886M6	2113944C47	R1042M1	0613952M66
C0887M6	NOT PLACED	R1043M1	0613952R66
C0888M6	2113944C42	R1044M1	0613952M66
C0900M6	NOT PLACED	R1045M1	0613952M66
C0901M6	NOT PLACED	R1046M1	0613952M66
C0902M6	2113944C51	R1047M1	0613952R66
C0905M6	2113945C31	R1048M1	0613952R66
C0906M6	2113945A10	R1049M1	0613952Q73
C0907M6	2113945L41	R1050M1	0613952Q73
C0908M6	21667009166	R1051M1	0613952K68
C0909M6	NOT PLACED	R1052M1	NOT PLACED
C0910M6	NOT PLACED	R1053M1	0613952R66
C0911M6	2113944C02	R1054M1	0613952M66
C0912M6	NOT PLACED	R1056M1	0613952Q73
C0913M6	21667009166	R1057M1	0613952Q73
C0916M6	NOT PLACED	R1058M1	0613952M66
C0917M6	21667009166	R1059M1	0613952R66
C0918M6	21667009166	R1060M1	0613952R66
C0919M6	21667009166	R1061M1	0613952R66
C0920M6	2113944C02	R1062M1	NOT PLACED
C0921M6	2113944C02	R1063M1	NOT PLACED
C0922M6	2113945C31	R1064M1	NOT PLACED
C0923M6	2113944C02	R1065M1	0613952R66
C0924M6	NOT PLACED	R1066M1	0613952M66
C0925M6	2113945C31	R1067M1	0613952M66
C0926M6	2113944C02	R1068M1	0613952R32
C0927M6	2113944C01	R1069M1	NOT PLACED
C0928M6	2113944C51	R1070M1	0613952Q77
C0929M6	2113944C49	R1071M1	0613952Q77
C0930M6	NOT PLACED	R1072M1	0613952Q49
C0950M6	2113944C47	R1073M1	0613952R01
C0951M6	21667011356	R1074M1	0613952R66
C0952M6	2113944C47	R1075M1	0613952R66

Circuit Ref.	Motorola Solutions Part No.	Circuit Ref.	Motorola Solutions Part No.
C0953M6	2113944C47	R1076M1	0613952R66
C0954M6	21667011457	R1077M1	0613952R66
C0955M6	2113944C47	R1078M1	0613952R66
C0956M6	2113944C01	R1079M1	0613952R66
C0957M6	2113944C49	R1080M1	0613952Q32
C1000M1	2113945Y02	R1081M1	0613952Q32
C1001M1	2113945Y02	R1082M1	0613952Q32
C1002M1	2113946K03	R1084M1	0613952R66
C1003M1	2113945Y02	R1088M1	NOT PLACED
C1004M1	2113945Y02	R1089M1	0613952R05
C1005M1	2113945Y02	R1090M1	0613952R05
C1006M1	2113945Y02	R1091M1	NOT PLACED
C1007M1	2113945Y02	R1092M1	0613952M43
C1008M1	2113946D05	R1093M1	0613952Q73
C1009M1	2113945Y02	R1094M1	0613952M66
C1010M1	2113945Y02	R1095M1	0613952Q34
C1011M1	2113945B02	R1096M1	0613952Q34
C1012M1	2113945Y02	R1097M1	0613952R66
C1013M1	2113945Y02	R1098M1	0613952R66
C1014M1	2113945Y02	R2000M1	0613952M66
C1015M1	2113945B02	R2002M1	0613952M66
C1016M1	21667009166	R2003M1	0613952M30
C1017M1	21667009162	R3000M6	0613952H60
C1018M1	21667009162	R3001M6	0615871H01
C1019M1	21667009162	R3002M6	0615871H01
C1020M1	21667009162	R3003M6	0615871H01
C1021M1	2113945Y02	R3004M6	0615871H01
C1022M1	2113945Y02	R3005M6	0613952H25
C1023M1	2113945Y02	R3006M6	0613952H25
C1024M1	2113945Y02	R3007M6	0613952M30
C1025M1	2113945Y02	R3008M6	0613952G67
C1026M1	2113945Y02	R3009M6	0613952M43
C1027M1	NOT PLACED	R3010M6	0613952G67
C1028M1	2113945Y02	R3011M6	0613959Q60
C1029M1	2113956B54	R3012M6	0613959Q60

Circuit Ref.	Motorola Solutions Part No.	Circuit Ref.	Motorola Solutions Part No.
C1032M1	2113956B54	R3013M6	0613952R01
C1035M1	2113945B02	R3014M6	0613952R01
C1036M1	2113946D05	R3015M6	0615871H01
C1040M1	2113945Y02	R3018M6	0613952H73
C1041M1	2113945B02	R3019M6	0613952H60
C1042M1	2113945Y02	R3020M6	0613952G67
C1043M1	2113956B54	R3021M6	0613952R25
C1044M1	2113945B02	R3101M1	0613952Z66
C1045M1	2113945B02	R3102M1	0613952M66
C1047M1	2113945Y02	R3103M1	0613952N62
C1048M1	2113945B02	R3104M1	0613952M30
C2000M1	2113945Y02	R3105M1	0613952R01
C2001M1	2113945Y02	R3106M1	0613952M09
C2002M1	2113945B02	R3107M1	0613952M85
C2003M1	21667009162	R3108M1	0613952R17
C2004M1	2113956B54	R3109M1	0613952R17
C2005M1	2113946D05	R3110M1	0613952N55
C2006M1	2113945Y02	R3111M1	0613952R32
C2007M1	2113945Y02	R3112M1	0613952P12
C2008M1	2113945B02	R3113M1	0613952R17
C2009M1	21667009162	R3114M1	0613952N01
C2010M1	2113945Y02	R3115M1	0613952Z63
C2011M1	2113945Y02	R3116M1	0613952E83
C2012M1	2113945Y02	R3117M1	0613952Q73
C2013M1	2113945Y02	R3118M1	0613952R10
C2014M1	2113945B02	R3119M1	0613952Q73
C2015M1	21667009162	R3120M1	0613952R66
C2016M1	2113956B54	R3121M1	0613952R66
C2020M1	2113956B54	R3122M1	0613952M43
C2021M1	2113956D59	R3123M1	0613952M54
C2022M1	2113956D59	R3124M1	0613952R66
C3000M6	2113944C38	R3125M1	0613952R66
C3001M6	2113944C06	R3126M1	0613952R66
C3002M6	2113944C06	R3127M1	0613959Y09
C3003M6	2113945C31	R3128M1	0613952M10

Circuit Ref.	Motorola Solutions Part No.	Circuit Ref.	Motorola Solutions Part No.
C3004M6	2113945C02	R3129M1	0613952M58
C3005M6	2113945C02	R3130M1	0613952R25
C3008M6	2113944C51	R3131M1	0613952R01
C3009M6	2113945C31	R3132M1	0613952R01
C3010M6	2113944C46	R3133M1	0613952R29
C3011M6	NOT PLACED	R3134M1	NOT PLACED
C3012M6	2113946J04	R3135M1	0613952R66
C3013M6	2113945C31	R3136M1	0613952R17
C3014M6	21009337414	R3137M1	0613952R17
C3015M6	2113946G01	R3138M1	0613952R17
C3016M6	2113945C31	R3139M1	0613952R66
C3019M6	2113946S35	R3140M1	0613952Q91
C3020M6	2113945C26	R3141M1	0613959Y13
C3021M6	2113944C06	R3142M1	NOT PLACED
C3022M6	2113945A10	R3143M1	0613952Q91
C3029M6	NOT PLACED	R3144M1	0613952R66
C3038M6	21667009379	R3145M1	0613959Y09
C3041M6	21667009379	R3146M1	0613952M85
C3042M6	21667009379	R3147M1	0613952M43
C3044M6	21667009379	R3148M1	0613952R66
C3046M6	NOT PLACED	R3149M1	0613952R01
C3047M6	NOT PLACED	R3150M1	0613952N62
C3048M6	NOT PLACED	R3151M1	0613952R25
C3049M6	NOT PLACED	R3153M1	0613952R66
C3102M1	21009337414	R3154M1	0613952Q89
C3103M1	21667009166	R3155M1	0613952Q89
C3104M1	2113946F08	R3156M1	0613952R17
C3105M1	2113946J04	R3157M1	0613952R01
C3106M1	2113945C31	R3158M1	0613952R66
C3107M1	2113944C38	R3159M1	0613952R01
C3109M1	21667009166	R3160M1	0613952Q89
C3110M1	2113944C06	R3161M1	0613952Q73
C3111M1	2113946J04	R3162M1	0613952Q85
C3112M1	2113945Y02	R3163M1	0613952R01
C3113M1	2113946S35	R3164M1	0613952Q75

Circuit Ref.	Motorola Solutions Part No.	Circuit Ref.	Motorola Solutions Part No.
C3115M1	2113944C06	R3165M1	0613952R01
C3116M1	2113955D13	R3166M1	0613952R17
C3117M1	2113955D13	R3167M1	0613952R01
C3118M1	2113945Y02	R3168M1	0613952Q73
C3119M1	2113945Y02	R3169M1	0613952R01
C3120M1	2113956E60	R3170M1	0613952R01
C3121M1	2113956D58	R3171M1	NOT PLACED
C3122M1	2113956A51	R3172M1	NOT PLACED
C3123M1	2113956A51	R3173M1	0613952R66
C3124M1	2113946D07	R3174M1	0613952R66
C3125M1	2113946D05	R3175M1	0689774Y02
C3126M1	2113944C06	R3176M1	0689774Y02
C3127M1	2113946S35	R3177M1	0613952R66
C3128M1	2113946D05	R3178M1	0615871H01
C3129M1	2113945Y02	R3179M1	0613952R17
C3130M1	2113946D05	R3180M1	0613952R01
C3131M1	2113946A02	R3181M1	NOT PLACED
C3132M1	2113946D05	R3182M1	0613952R66
C3133M1	2113946D05	R3183M1	0613952H92
C3134M1	2113946S35	R3184M1	0613952M30
C3135M1	2113956A51	R3200M1	0613952C44
C3136M1	21012095001	R3201M1	0613952Q49
C3137M1	2113946D05	R3202M1	0613952C44
C3139M1	2113956A51	R3203M1	0613952Q49
C3140M1	21012095001	R3204M1	0613952C44
C3141M1	2113945Y02	R3205M1	0613952C44
C3142M1	21012102001	R3206M1	0613952R01
C3143M1	21667009366	R3207M1	0613952R01
C3144M1	2113945Y02	R3208M1	0613952N30
C3145M1	2113944C06	R3209M1	0613952R03
C3146M1	21012102001	R3210M1	0613952Q67
C3149M1	2113956A51	R3211M1	0613952N30
C3150M1	2113956C37	R3212M1	0613952R03
C3151M1	2113945B02	R3213M1	0613952Q42
C3152M1	2113944C06	R3214M1	0613952J25

Circuit Ref.	Motorola Solutions Part No.	Circuit Ref.	Motorola Solutions Part No.
C3153M1	2113946J04	R3215M1	0613952R01
C3154M1	2113955D13	R3216M1	0613952R17
C3155M1	2113945Y02	R3217M1	0613952R01
C3156M1	2113945Y02	R3218M1	0613952R01
C3157M1	2113945Y02	R3219M1	NOT PLACED
C3160M1	2113945Y02	R3220M1	0613952R01
C3161M1	NOT PLACED	R3221M1	NOT PLACED
C3171M1	2113946D07	R3222M1	0613952R01
C3173M1	2113946D07	R3223M1	0613952R66
C3175M1	2113946A01	R3224M1	NOT PLACED
C3176M1	2113944C48	R3225M1	NOT PLACED
C3177M1	2113946F08	R3226M1	0613952R01
C3200M1	21667009166	R3229M1	0613952R01
C3201M1	21667009166	R3230M1	0613952R10
C3203M1	2113955D37	R3231M1	0613952R10
C3204M1	2113955D37	R3232M1	0613952R10
C3205M1	21667009166	R3233M1	0613952R01
C3206M1	21667009166	R3234M1	NOT PLACED
C3208M1	2113956C37	R3235M1	0613952R01
C3209M1	2113945Y02	R3236M1	0613952R10
C3210M1	2113945Y02	R3237M1	NOT PLACED
C3211M1	2113945A11	R3238M1	0613952R01
C3212M1	2113955D37	R3239M1	0613952Q49
C3213M1	2113945A03	R3240M1	0613952R01
C3214M1	2113955D37	R3241M1	0613952M54
C3215M1	2113956F49	R3242M1	0613952R01
C3216M1	2113945Y02	R3243M1	0613952R01
C3217M1	2113956B91	R3244M1	0613952R10
C3218M1	2113956A51	R3245M1	NOT PLACED
C3219M1	2113956A51	R3246M1	0613952R01
C3220M1	2113946F05	R3247M1	0613952Q49
C3221M1	2113945Y02	R3248M1	0613952R66
C3222M1	2113956A51	R3249M1	0613952R66
C3223M1	2113945Y02	R3250M1	0613952R66
C3224M1	2113946F05	R3251M1	0613952R66

Circuit Ref.	Motorola Solutions Part No.	Circuit Ref.	Motorola Solutions Part No.
C3225M1	2113945Y02	R3252M1	0613952R66
C3226M1	NOT PLACED	R3253M1	0613952R66
C3227M1	2113946F05	R3254M1	0613952R01
C3228M1	2113945Y02	R3255M1	0613952R66
C3229M1	2113956A51	R3256M1	0613952M66
C3230M1	2113945Y02	R3257M1	0613952R01
C3231M1	2113945Y02	R3258M1	0613952M66
C3232M1	2113945Y02	R3259M1	0613952M66
C3233M1	2113945A09	R3260M1	0613952M66
C3234M1	2113945Y02	R3261M1	0613952R01
C3235M1	21012102001	R3262M1	0613952R10
C3236M1	2113945C31	R3263M1	NOT PLACED
C3237M1	21009337414	R3264M1	0613952R01
C3238M1	2113945A09	R3265M1	0613952M66
C3239M1	2113945A09	R3266M1	0613952R01
C3240M1	2113956B91	R3267M1	NOT PLACED
C3241M1	2113956B91	R3268M1	0613952R01
C3242M1	2113945C31	R3269M1	0613952M66
C3243M1	2113955D37	R3270M1	0613952R01
C3244M1	2113956B91	R3271M1	NOT PLACED
C3245M1	2113955D37	R3272M1	0613952R01
C3246M1	2113945C31	R3273M1	0613952M66
C3247M1	2113945Y02	R3274M1	0613952R10
C3248M1	2113945Y02	R3275M1	0613952R10
C3249M1	2113956B91	R3276M1	0613952R10
C3250M1	2113956B91	R3277M1	0613952R10
C4000M1	2113945Y02	R3278M1	0613952R01
C4001M1	2113945Y02	R3279M1	NOT PLACED
C4002M1	2113945Y02	R3280M1	NOT PLACED
C4003M1	2113945Y02	R3281M1	NOT PLACED
C4010M1	21667009166	R3282M1	0613952R66
C4011M1	21667009166	R3283M1	0613952R66
C4012M1	21667009166	R3285M1	0613952R01
C4013M1	21667009166	R3286M1	0613952R66
C4014M1	21667009166	R3287M1	0613952R66

Circuit Ref.	Motorola Solutions Part No.	Circuit Ref.	Motorola Solutions Part No.
C4015M1	21667009166	R3288M1	0613952R01
C4019M1	21667009166	R3289M1	0613952R01
C4020M1	21667009166	R3290M1	NOT PLACED
C4021M1	21667009166	R3291M1	NOT PLACED
C4022M1	21667009166	R3292M1	0613952R66
C4023M1	21667009166	R3293M1	0613952R66
C4025M1	21667009166	R4001M1	0613952R66
C4026M1	21667009166	R4003M1	0613952R66
C4027M1	21667009166	R4006M1	0613952Q37
C4028M1	21667009166	R4007M1	0613952Q37
C4029M1	21667009166	R4008M1	0613952R01
C4030M1	21667009166	R4010M1	0613952R01
C4100M1	21667009166	R4013M1	0613952Q42
C4101M1	21667009166	R4015M1	0613952Q37
C4103M1	21667009166	R4021M1	0613952R66
C4104M1	21667009166	R4024M1	0613952R01
C4105M1	21667009166	R4025M1	0613952R01
C4106M1	21667009166	R4026M1	0613952R66
C4107M1	21667009166	R4027M1	0613952R66
C4108M1	21667009166	R4028M1	0613952R01
C4109M1	21667009166	R4029M1	0613952R01
C4110M1	21667009166	R4030M1	0613952R01
C4112M1	21667009166	R4031M1	0613952R01
C4113M1	21667009166	R4032M1	0613952R66
C4114M1	21667009166	R4033M1	0613952M43
C4115M1	21667009166	R4034M1	0613952M43
C4116M1	21667009166	R4035M1	0613952R66
C4117M1	21667009166	R4036M1	0613952R66
C4118M1	21667009166	R4037M1	0613952R01
C4119M1	21667009166	R4038M1	0613952R01
C4200M1	2113945Y02	R4039M1	NOT PLACED
C4201M1	2113945Y02	R4040M1	NOT PLACED
C4202M1	21667009166	R4041M1	NOT PLACED
C4203M1	21667009166	R4100M1	0613952R01
C4204M1	NOT PLACED	R4101M1	0613952Q77

Circuit Ref.	Motorola Solutions Part No.	Circuit Ref.	Motorola Solutions Part No.
C4205M1	21667009166	R4102M1	0613958H83
C4206M1	21667009166	R4103M1	0613952Q85
C4207M1	21667009166	R4104M1	0613952Q89
C4208M1	21667009166	R4105M1	0613952Q89
C4209M1	21667009166	R4106M1	0613952Q89
C4210M1	21667009166	R4107M1	0613952R01
C4211M1	21667009166	R4108M1	0613952Q89
C4212M1	21667009166	R4109M1	0613952N58
C4213M1	21667009166	R4110M1	0613952Q85
C4214M1	21667009166	R4111M1	0613952Q85
C4218M1	21667009166	R4112M1	0613952R01
C4219M1	21667009339	R4113M1	0613952R01
C4220M1	21667009339	R4114M1	0613952Q89
C4221M1	21667009339	R4115M1	0613952N58
C4222M1	21667009339	R4116M1	0613952Q89
C4223M1	21667009339	R4117M1	0613952R01
C4224M1	21667009166	R4118M1	0613952R01
C4225M1	21667009166	R4119M1	0613952R01
C4226M1	21667009339	R4120M1	0613952N58
C4300M1	NOT PLACED	R4121M1	0613952Q85
C4301M1	NOT PLACED	R4122M1	0613952Q85
C4302M1	NOT PLACED	R4123M1	0613952N58
C4303M1	NOT PLACED	R4124M1	0613952N58
C4304M1	21667009166	R4125M1	0613952Q85
C4305M1	21667009376	R4126M1	0613952Q85
C4306M1	21667009381	R4127M1	0613952Q85
C4307M1	NOT PLACED	R4128M1	0613952R01
C4308M1	NOT PLACED	R4200M1	0613952R66
C4309M1	21667009166	R4201M1	0613952R66
C4310M1	21667009166	R4202M1	0613952R66
C4311M1	2113945Y02	R4203M1	0613952R66
C4312M1	2113945Y02	R4204M1	0613952R66
C4313M1	21667009166	R4205M1	0613952R66
C4314M1	NOT PLACED	R4206M1	0613952R66
C4401M1	NOT PLACED	R4207M1	0613952R66

Circuit Ref.	Motorola Solutions Part No.	Circuit Ref.	Motorola Solutions Part No.
C4402M1	NOT PLACED	R4208M1	0613952R66
C4403M1	NOT PLACED	R4209M1	HZ000375A01
C4404M1	NOT PLACED	R4210M1	HZ000375A01
C4405M1	NOT PLACED	R4211M1	HZ000375A01
C4406M1	NOT PLACED	R4212M1	HZ000375A01
C4407M1	NOT PLACED	R4213M1	HZ000375A01
C4408M1	NOT PLACED	R4214M1	HZ000375A01
C4409M1	NOT PLACED	R4215M1	0613952R66
C4410M1	NOT PLACED	R4216M1	0613952R66
C4411M1	NOT PLACED	R4217M1	0613952R66
C4412M1	21667009166	R4218M1	0613952R66
C4413M1	21667009166	R4301M1	NOT PLACED
C4414M1	21667009166	R4302M1	0613952R66
C4415M1	21667009166	R4303M1	0613952R66
C4417M1	21667009166	R4304M1	0613952R66
C4418M1	21667009166	R4305M1	0613952R66
C4419M1	21667009166	R4306M1	0613952R66
D0000M2	4815011H01	R4307M1	0613952R66
D0001M2	4815011H01	R4309M1	NOT PLACED
D0400M4	4884800Y03	R4310M1	0613952R66
D0401M4	4813974A19	R4311M1	0613952R66
D0402M4	4813974A19	R4312M1	0613952R66
D0403M4	4884800Y03	R4313M1	NOT PLACED
D0404M4	4815090H01	R4314M1	0613952R66
D0500M3	4813974A19	R4315M1	0613952R66
D0700M6	NOT PLACED	R4316M1	0613952R66
D0875M6	48012160001	R4317M1	0613952R66
D0876M6	4886622Y06	RT0900M6	0615585H01
D0877M6	48012160001	SH0000M2	26012095001
D0900M6	NOT PLACED	SH0001M2	26012095001
D0950M6	4813974A21	SH0002M2	26012097001
D0951M6	4813974A21	SH0003M2	26012094001
D3000M6	4813978P07	SH0004M2	26012094001
D3104M1	4885489Y01	SH0200M7	26012095001
D3160M1	4813978C02	SH0300M7	26012095001

Circuit Ref.	Motorola Solutions Part No.	Circuit Ref.	Motorola Solutions Part No.
D3161M1	4813978C02	SH0400M4	26012096001
E0000M2	24012107027	SH0401M4	26012096001
E0001M2	24012107027	SH0402M4	26012098001
E0002M2	NOT PLACED	SH0403M4	26012098001
E0003M2	24012107027	SH0500M3	26012098001
E0004M2	24012107027	SH0501M3	NOT PLACED
E0005M2	24012107027	SH0850M6	26012100001
E0006M2	24012107027	SH0900M6	2686425Z02
E0007M2	24012107027	SH0901M6	2686425Z02
E0008M2	24012107027	SH3100M1	NOT PLACED
E0009M2	24012107027	SP3000M6	NOT PLACED
E0010M2	24012107027	SP3001M6	NOT PLACED
E0200M7	24012107027	T0000M2	25012016001
E0300M7	24012107027	T0400M4	2515121H01
E0401M4	24012107027	T0401M4	2515121H01
E0402M4	24012107027	U0000M2	51009877001
E0403M4	24012107027	U0001M2	5109731C48
E0404M4	24012107027	U0002M2	4802197J95
E0500M3	24012107027	U0200M7	5186310Y39
E0700M6	24012102001	U0500M3	4802197J95
E0701M6	24012102001	U0901M6	5180390L83
E0703M6	24012102001	U0902M6	51012221001
E1000M1	7686949J15	U0903M6	5115022H01
E1001M1	7686949J15	U0904M6	5109731C48
E1002M1	7686949J15	U0905M6	5109731C48
E1003M1	7686949J15	U1000M1	5171320H01
E1004M1	7686949J15	U1001M1	51012295001
E1005M1	7686949J15	U1002M1	5189139P01
E1006M1	7685268E01	U1003M1	5175772B56
E3000M6	24012102001	U1004M1	5175772B56
E3100M1	24012102001	U1005M1	5164852H47
E3101M1	2485410Y02	U1006M1	5185493Y01
E3102M1	2485410Y02	U1007M1	5189139P01
E3103M1	2485410Y02	U1008M1	5189139P01
E3104M1	7686949J22	U1009M1	5115001H02

Circuit Ref.	Motorola Solutions Part No.	Circuit Ref.	Motorola Solutions Part No.
E3105M1	7686949J22	U1010M1	5171320H01
E3106M1	7686949J22	U2000M1	MM000157A01
E3107M1	7686949J22	U2001M1	MM000129A01
E3108M1	7686949J22	U3000M6	5116525H01
E3109M1	7686949J22	U3001M6	4813973M07
E3110M1	7686949J22	U3002M6	51012133001
E3111M1	7686949J22	U3100M1	0104039J08
E3113M1	7686949J22	U3101M1	5114014A01
E3200M1	24012102001	U3102M1	51012069001
E3201M1	24012102001	U3103M1	51012142001
E3202M1	24012107027	U3104M1	5171590Y73
E3203M1	24012102001	U3105M1	5114610F01
E3204M1	24012102001	U3106M1	51012140001
E4000M1	24012107027	U3107M1	51012140001
E4001M1	7688697V05	U3108M1	51012138001
E4002M1	24012107027	U3109M1	5164015H94
E4003M1	NOT PLACED	U3110M1	51012208001
E4004M1	24012102001	U3111M1	5188690V02
E4005M1	2485410Y02	U3112M1	5114004A35
E4100M1	7686949J14	U3113M1	5188690V02
E4101M1	24012107027	U3114M1	NOT PLACED
E4102M1	NOT PLACED	U3115M1	5185937Y01
E4103M1	NOT PLACED	U3200M1	51009415001
E4104M1	NOT PLACED	U3201M1	5114016A18
E4200M1	24012107027	U3204M1	51009509001
E4201M1	24012107027	U3205M1	5114016A18
E4202M1	24012107027	U4000M1	51012082001
E4300M1	24012107027	U4001M1	51012082001
E4405M1	24012107027	U4100M1	5189139P01
E4406M1	7686949J22	U4200M1	NOT PLACED
E4407M1	7686949J22	U4201M1	NOT PLACED
E4408M1	24012107027	U4300M1	51012082001
E4409M1	24012102001	U4301M1	51012082001
F4000M1	65012019001	VR0001M2	4815096H01
FL0500M3	9116854H02	VR0200M7	4805656W87

Circuit Ref.	Motorola Solutions Part No.	Circuit Ref.	Motorola Solutions Part No.
FL4000M1	24012038001	VR0201M7	4805656W87
FL4001M1	24012038001	VR0202M7	4805656W87
J4000M1	0915767H01	VR0203M7	4805656W87
J4001M1	0915556H01	VR0204M7	4805656W87
J4100M1	0916017H01	VR0205M7	4805656W87
J4200M1	09012053001	VR0206M7	4805656W87
J4400M1	09012053001	VR0207M7	4805656W87
L0000M2	24012154001	VR0208M7	4805656W87
L0001M2	24667008020	VR0209M7	4805656W87
L0002M2	24667000031	VR0210M7	4805656W87
L0003M2	24667008031	VR0211M7	4805656W87
L0004M2	24009343017	VR0214M7	4805656W87
L0005M2	24667008017	VR0215M7	4805656W87
L0200M7	24667008031	VR0400M4	4805656W87
L0201M7	24667008031	VR0401M4	4805656W87
L0202M7	2415385H02	VR0402M4	4805656W87
L0203M7	24009343013	VR0403M4	4805656W87
L0204M7	24667008031	VR0404M4	4805656W87
L0205M7	24667008031	VR0405M4	4805656W87
L0206M7	24667008031	VR0406M4	4805656W87
L0207M7	24667008031	VR0407M4	4805656W87
L0208M7	24667008031	VR3000M6	48012202001
L0209M7	24667008031	VR3002M6	4813977M10
L0210M7	24009343006	VR3103M1	48012095001
L0211M7	2415385H01	VR3104M1	48012095002
L0212M7	24667008031	VR3105M1	4813977M10
L0214M7	24009343006	VR3200M1	48012049001
L0216M7	2415385H02	VR3201M1	4813977A48
L0218M7	24667008031	VR3202M1	4813977A48
L0220M7	24667008031	VR4000M1	4813977M13
L0222M7	24667008031	VR4001M1	4813977A48
L0224M7	24667008030	VR4002M1	48012153001
L0226M7	24667008021	VR4100M1	4813977A48
L0300M7	24667008014	VR4101M1	4813977A48
L0301M7	24667008031	VR4102M1	4813977A48

Circuit Ref.	Motorola Solutions Part No.	Circuit Ref.	Motorola Solutions Part No.
L0302M7	24667008030	VR4103M1	4813977A48
L0303M7	24667008013	VR4104M1	48012049001
L0304M7	24667008019	VR4105M1	4813977M13
L0305M7	24667008014	VR4106M1	4813977A48
L0401M4	24012021001	VR4107M1	4813977A48
L0402M4	24009344102	VR4108M1	4813977A48
L0403M4	24667008030	VR4109M1	4813977A50
L0404M4	24009344109	VR4110M1	4815040H01
L0405M4	2416540H31	VR4111M1	48012153001
L0406M4	24012021001	Y0000M2	4875185M05
L0407M4	24012021001	-	-



NOTICE: The suffix "M1", "M2", and so on from the Circuit Ref. is removed from the schematic and overlays.

8.6.1.3

Circuit Board and Schematic Diagrams for 84012737003-C

Figure 212: Main Board Top Side PCB No. 84012737003-C

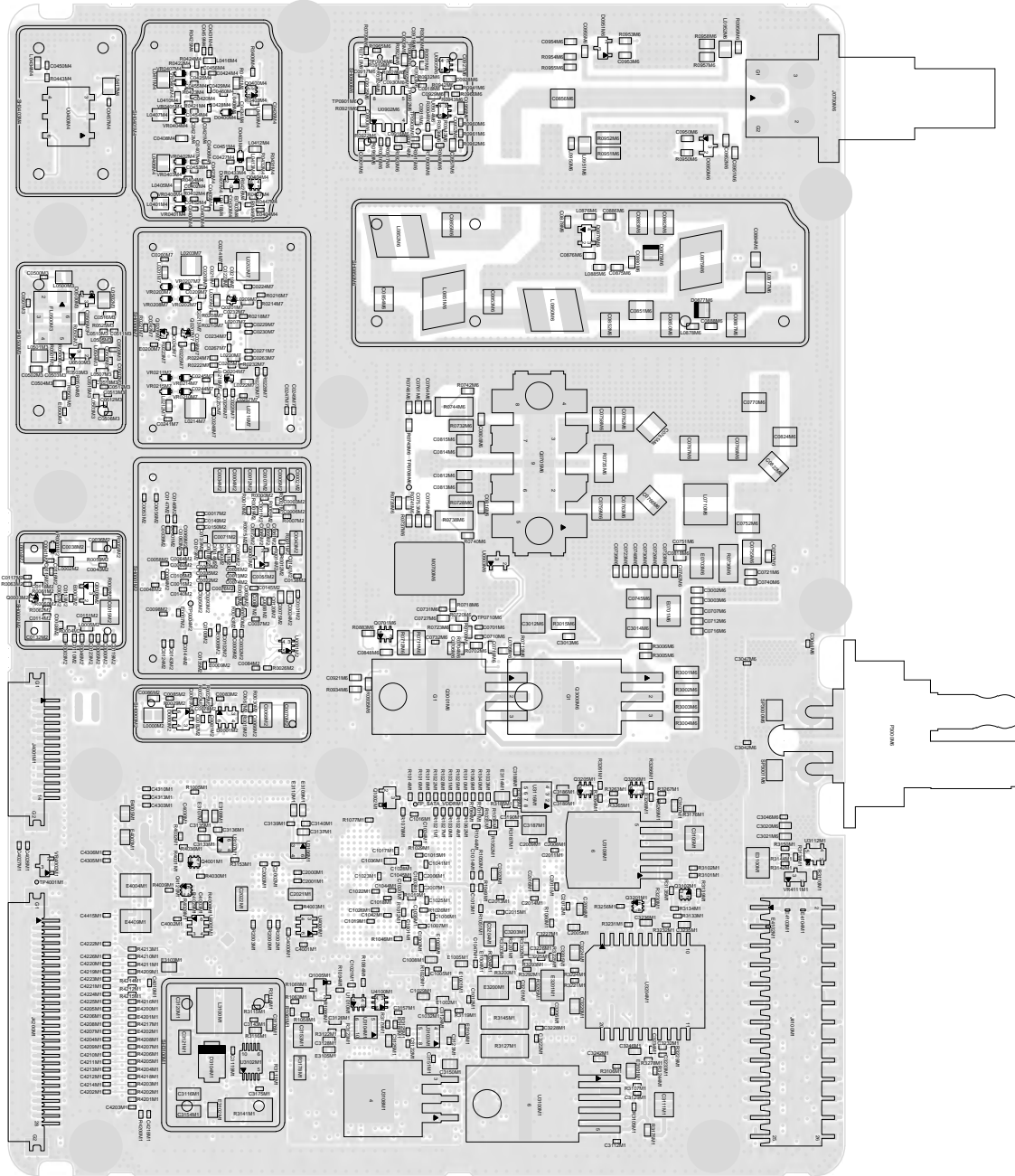

Figure 213: Main Board Bottom Side PCB No. 84012737003-C

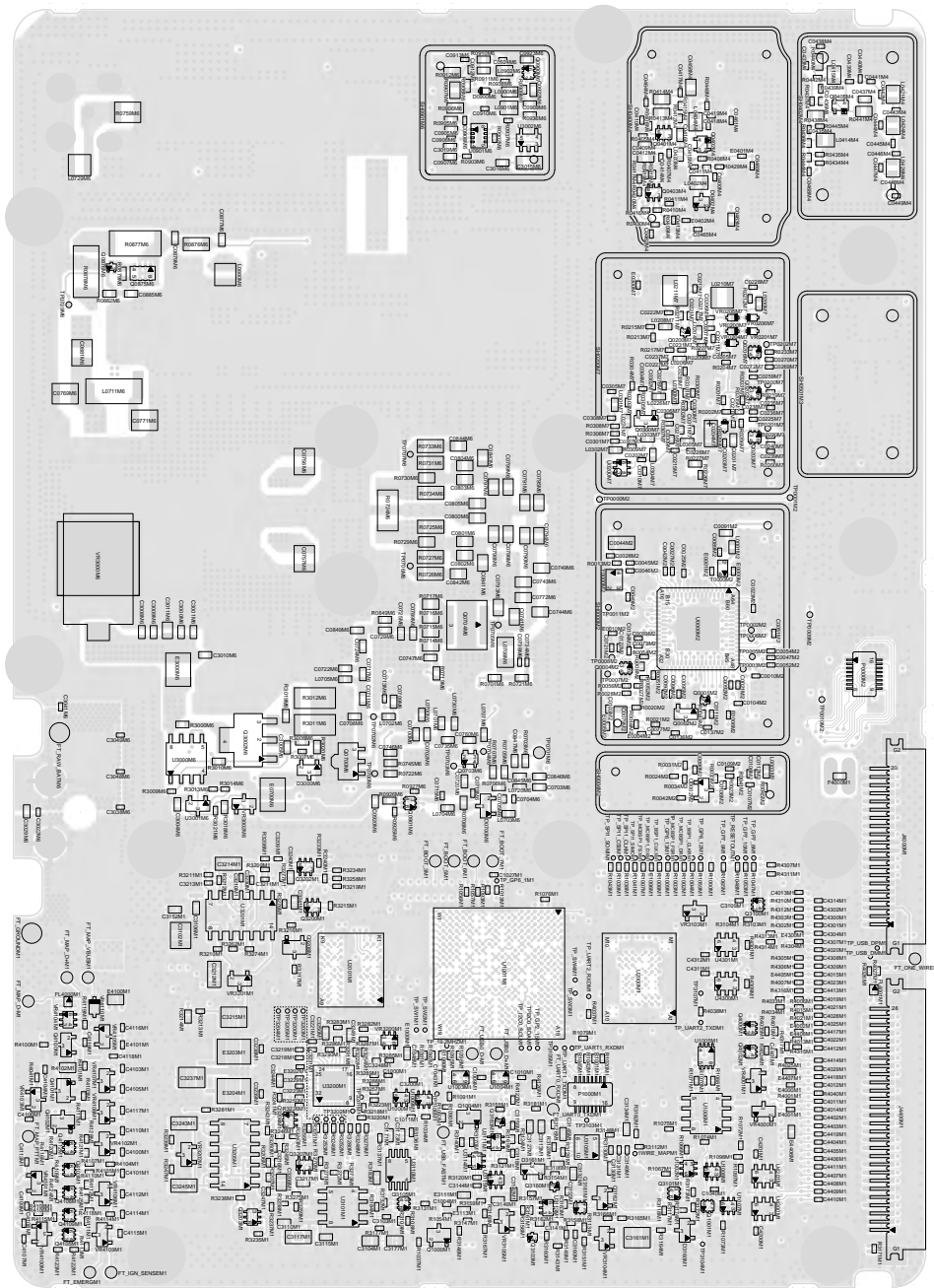

Figure 214: Overall Schematic Diagram

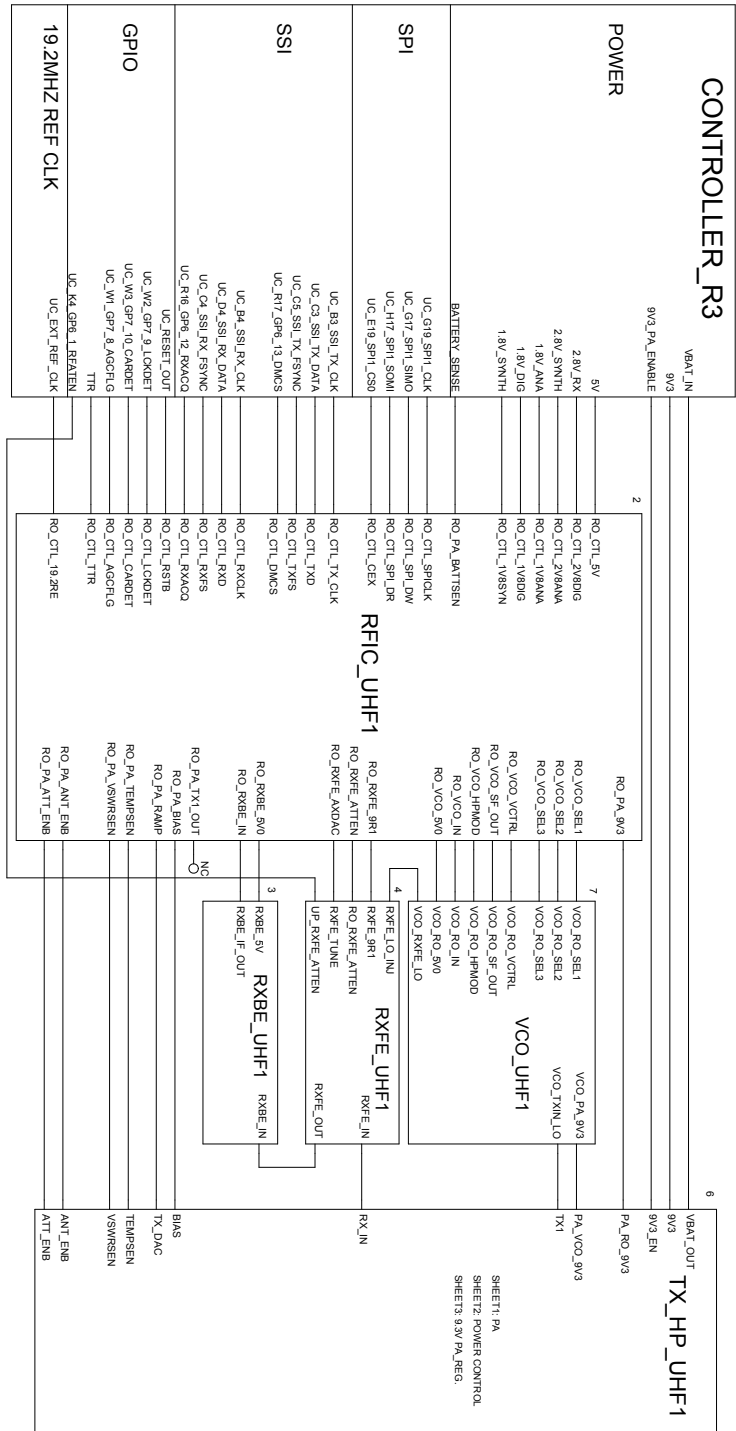

Figure 215: Receiver Front-End Schematic Diagram

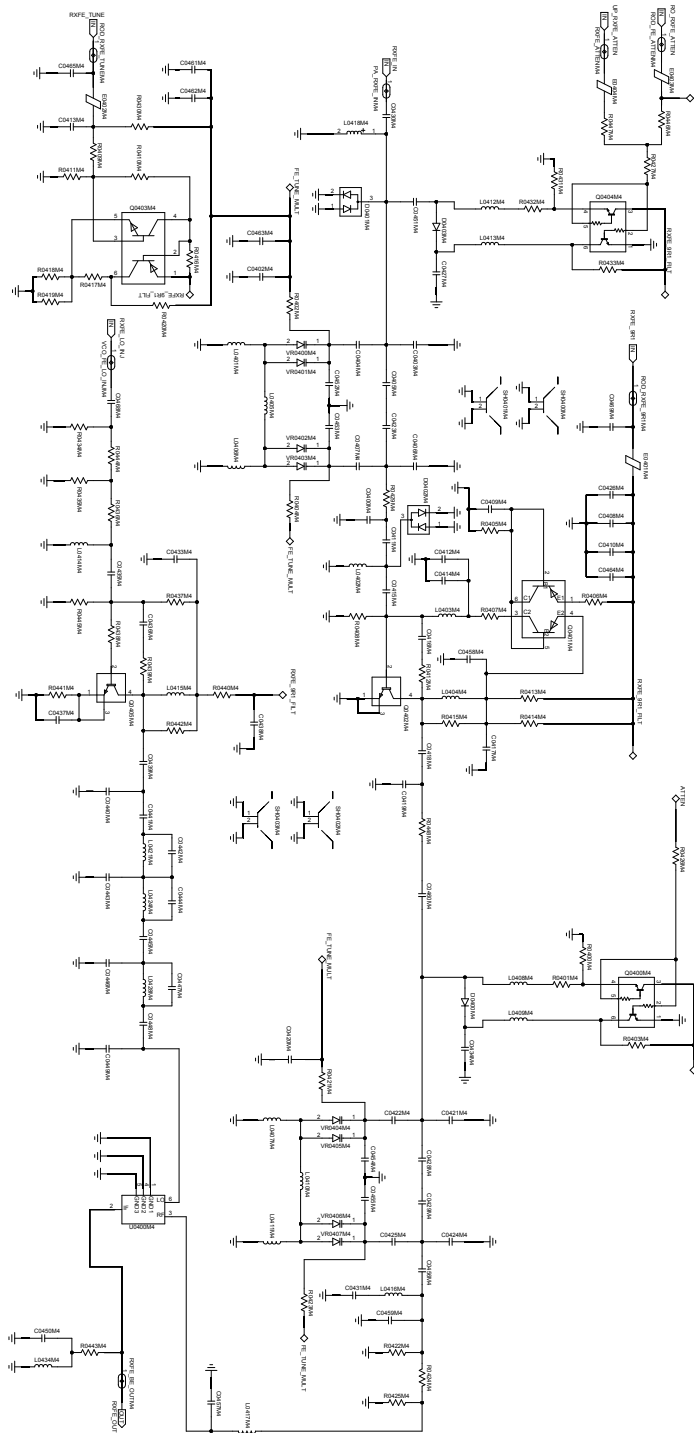

Figure 216: Receiver IF Amp Schematic Diagram

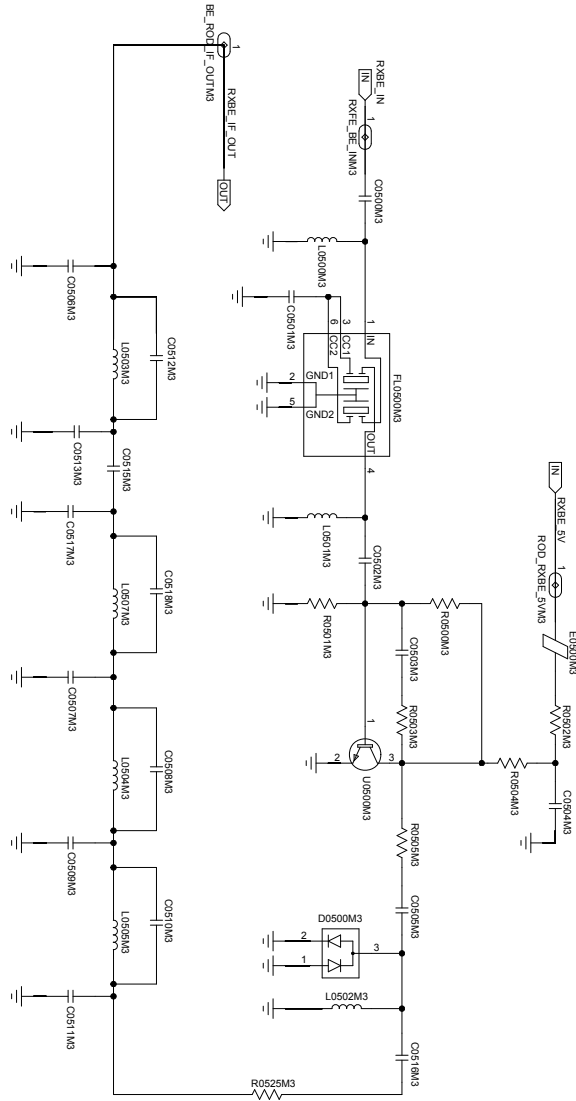
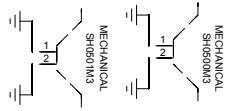

Figure 217: Transmitter Power Amplifier Schematic Diagram

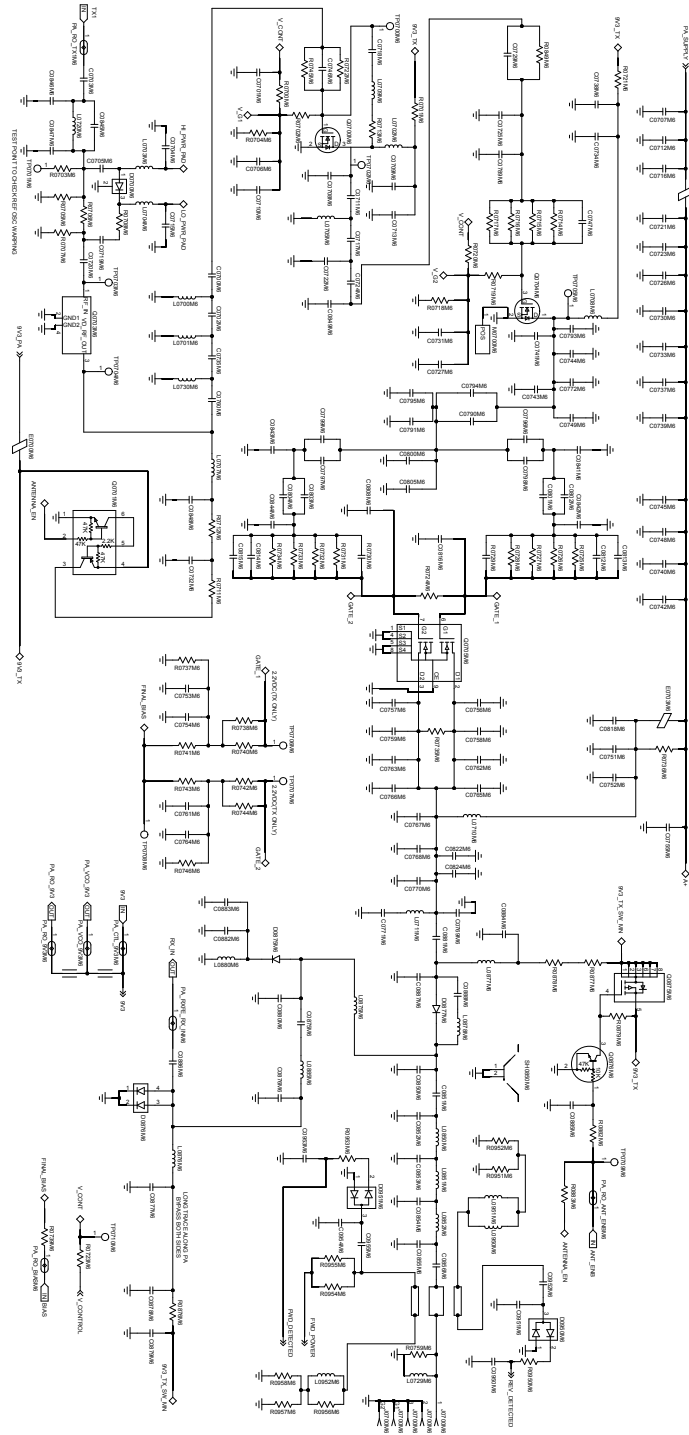
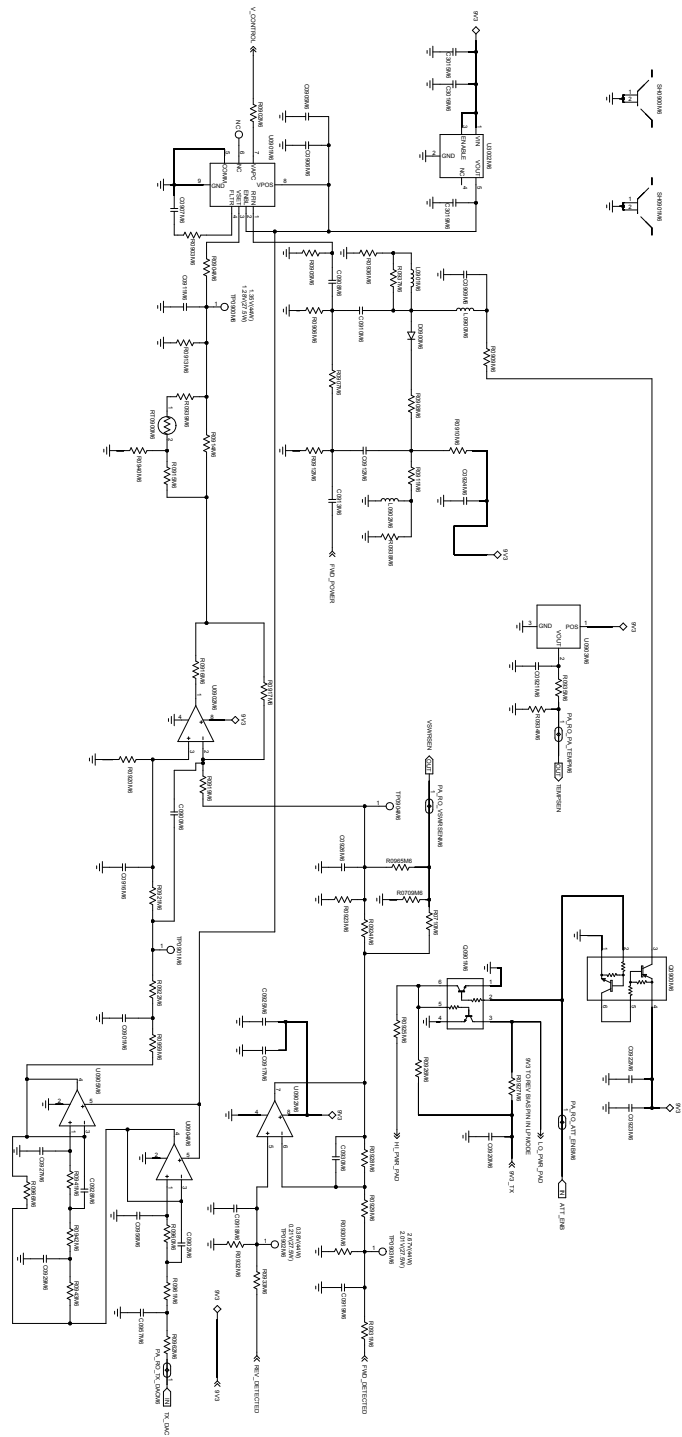

Figure 218: Power Control Schematic Diagram



NOTE: VOLTAGE SHOWN FOR ANALOG TX MODE

Figure 219: Transmitter Power Amplifier DC Distribution Schematic Diagram

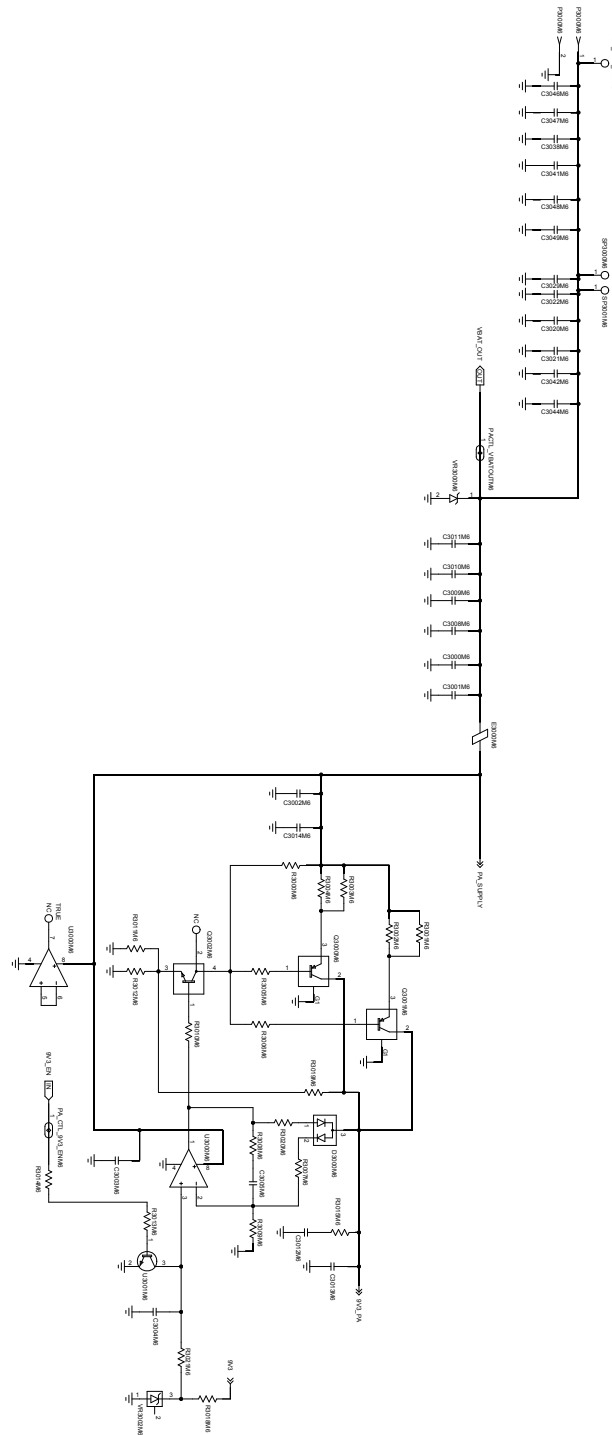

Figure 221: Receiver VCO Schematic Diagram

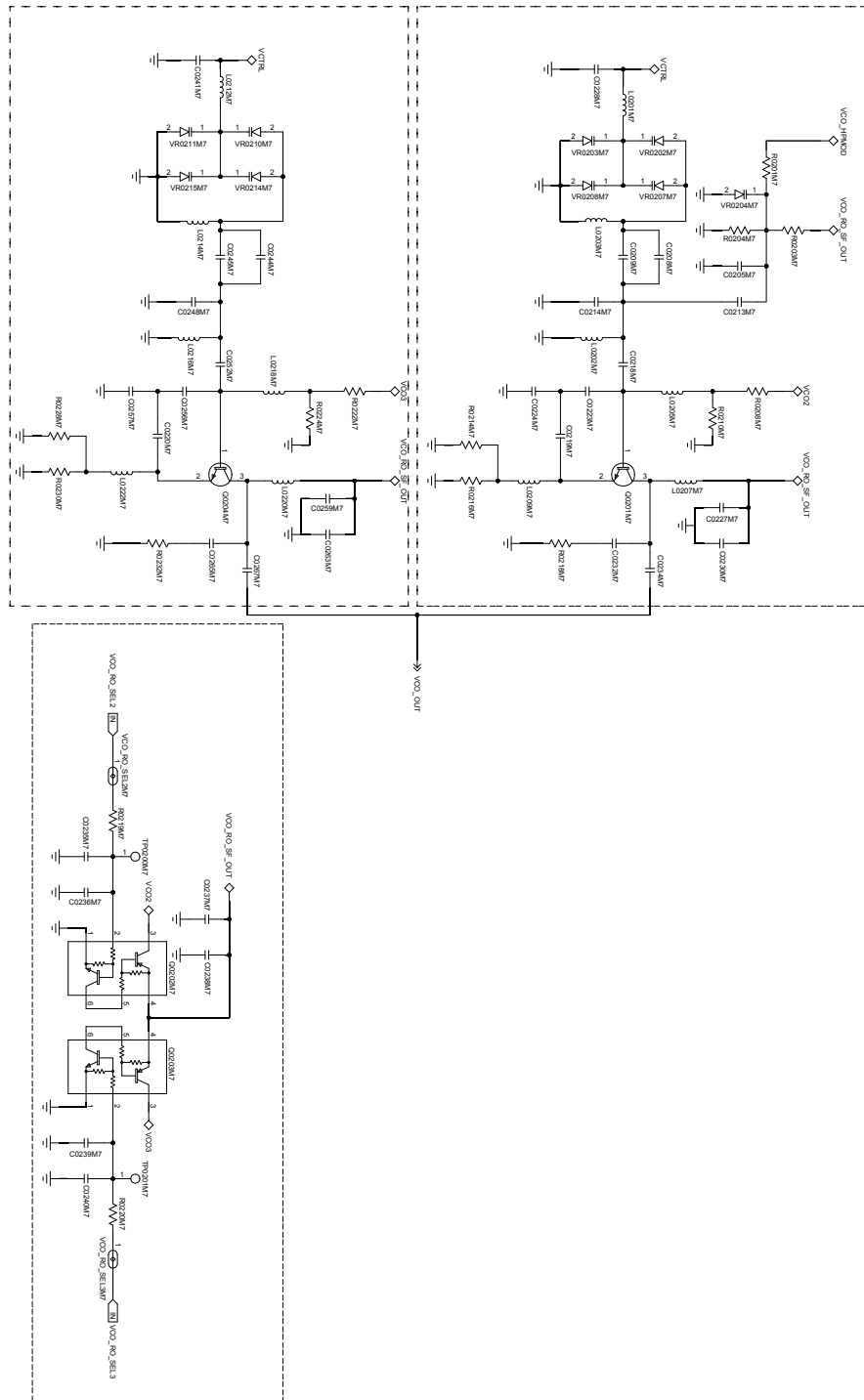
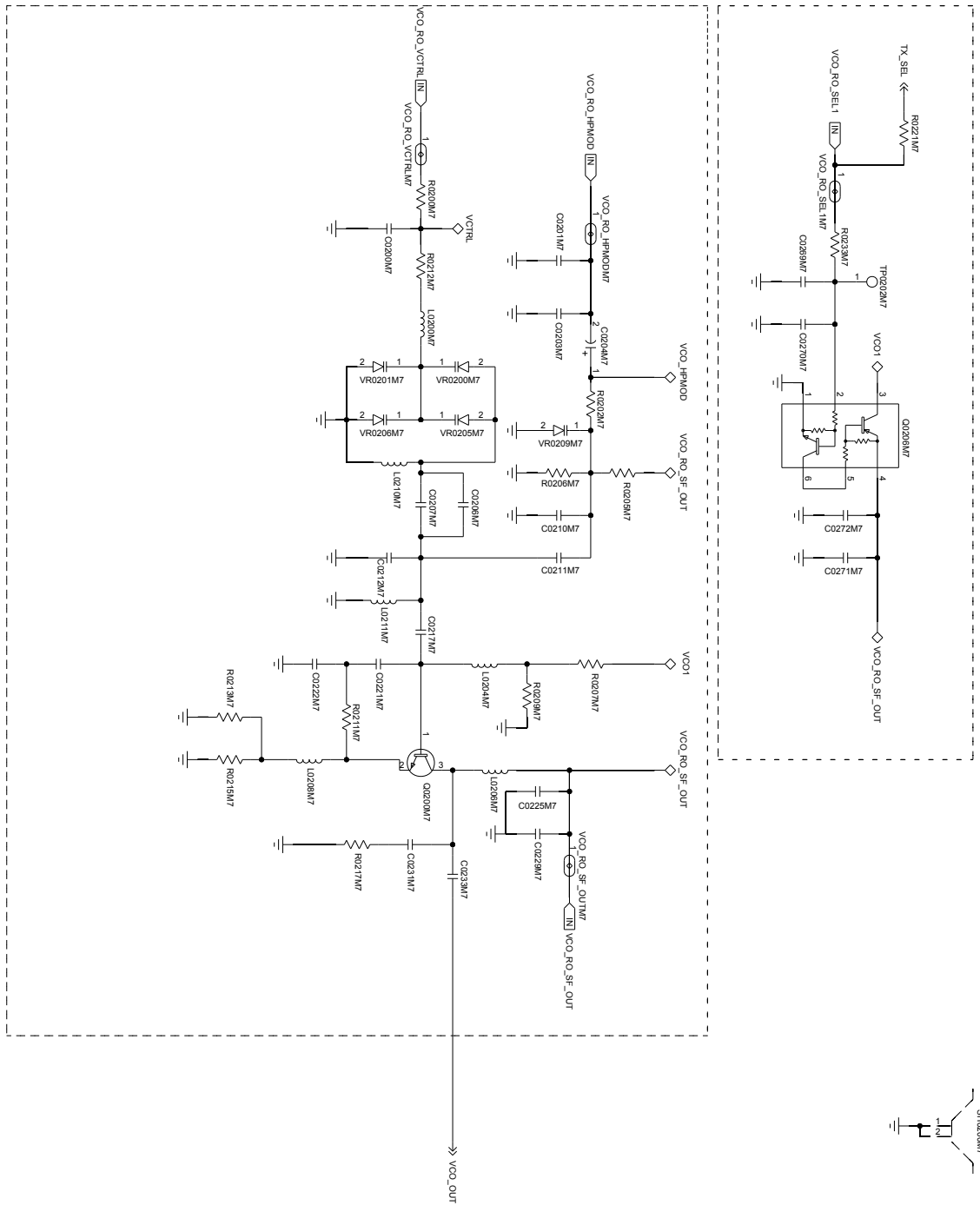

Figure 222: Transmit VCO Schematic Diagram



8.6.1.4
Parts List for 84012737003-C

Table 24: UHF1 Radio Parts List

Circuit Ref.	Motorola Solutions Part No.	Circuit Ref.	Motorola Solutions Part No.
C0000M2	21667009311	D0876M6	4886622Y06
C0001M2	21667009170	D0877M6	48012160001
C0002M2	21012044001	D0900M6	NOT PLACED
C0003M2	NOT PLACED	D0950M6	4813974A21
C0004M2	21012044001	D0951M6	4813974A21
C0005M2	21012044001	D3000M6	4813978P07
C0006M2	2113945C31	E0000M2	24012107027
C0007M2	21012044001	E0001M2	24012107027
C0008M2	21667009311	E0002M2	NOT PLACED
C0009M2	21667009166	E0003M2	24012107027
C0010M2	21667009166	E0004M2	24012107027
C0011M2	2113945C31	E0005M2	24012107027
C0012M2	21012044001	E0006M2	24012107027
C0013M2	2113945Y02	E0007M2	24012107027
C0014M2	2113945Y02	E0008M2	24012107027
C0015M2	2113946J03	E0009M2	24012107027
C0016M2	2113945A10	E0010M2	24012107027
C0017M2	2113945Y02	E0200M7	24012107027
C0018M2	2113945A10	E0300M7	24012107027
C0019M2	2113945Y02	E0401M4	24012107027
C0020M2	2113945A10	E0402M4	24012107027
C0021M2	2113945Y02	E0403M4	24012107027
C0022M2	2113945Y02	E0404M4	24012107027
C0023M2	2113945Y02	E0500M3	24012107027
C0024M2	21012102001	E0700M6	24012102001
C0025M2	21667009166	E0701M6	24012102001
C0026M2	21667009174	E0703M6	24012102001
C0027M2	2113945Y02	E3000M6	24012102001
C0028M2	2113945Y02	FL0500M3	9116854H03
C0029M2	2113945A10	J0700M6	09009348002
C0030M2	2113945A10	L0000M2	24012154001
C0031M2	2113945Y02	L0001M2	24667008020

Circuit Ref.	Motorola Solutions Part No.	Circuit Ref.	Motorola Solutions Part No.
C0032M2	21667009166	L0002M2	24667000031
C0034M2	21012044001	L0003M2	24667008031
C0035M2	21667009166	L0004M2	24009343017
C0036M2	21012025001	L0005M2	24667008017
C0037M2	21667009166	L0200M7	24667008031
C0038M2	21012044001	L0201M7	24667008031
C0039M2	2113945Y02	L0202M7	2415385H02
C0040M2	2113945A10	L0203M7	24009343013
C0041M2	21667009364	L0204M7	24667008031
C0042M2	21667009166	L0205M7	24667008031
C0043M2	21012044002	L0206M7	24667008031
C0044M2	2113955D45	L0207M7	24667008031
C0045M2	2113945Y02	L0208M7	24667008031
C0046M2	21667009166	L0209M7	24667008031
C0047M2	21667009166	L0210M7	24009343006
C0048M2	21667009166	L0211M7	2415385H01
C0049M2	2113945B02	L0212M7	24667008031
C0050M2	21667009166	L0214M7	24009343006
C0051M2	21667009166	L0216M7	2415385H02
C0052M2	21667009166	L0218M7	24667008031
C0053M2	21667009166	L0220M7	24667008031
C0054M2	21667009166	L0222M7	24667008031
C0055M2	2113955D37	L0224M7	24667008030
C0056M2	2113945Y02	L0226M7	24667008021
C0057M2	2113945B02	L0300M7	24667008014
C0058M2	NOT PLACED	L0301M7	24667008031
C0059M2	21667009166	L0302M7	24667008030
C0060M2	2113945A69	L0303M7	24667008013
C0061M2	2113945Y02	L0304M7	24667008019
C0062M2	NOT PLACED	L0305M7	24667008014
C0063M2	NOT PLACED	L0401M4	24012021001
C0064M2	2113945A69	L0402M4	24009344102
C0065M2	2113945Y02	L0403M4	24667008030
C0066M2	2113945B02	L0404M4	24009344123
C0067M2	2113945Y02	L0405M4	2416540H31

Circuit Ref.	Motorola Solutions Part No.	Circuit Ref.	Motorola Solutions Part No.
C0068M2	2113955D37	L0406M4	24012021001
C0069M2	NOT PLACED	L0407M4	24012021001
C0070M2	2113955D37	L0408M4	24667008030
C0071M2	2113955D37	L0409M4	24667008030
C0072M2	21667009166	L0410M4	24667008025
C0073M2	21667009166	L0411M4	24012021001
C0074M2	21667009166	L0412M4	24667008030
C0075M2	2113946S35	L0413M4	24667008030
C0076M2	2113946S35	L0414M4	24009344106
C0077M2	21667009166	L0415M4	24009344108
C0078M2	21667009372	L0416M4	24667008017
C0079M2	2113955D37	L0417M4	24009344107
C0080M2	2113945B02	L0418M4	NOT PLACED
C0081M2	2113945B02	L0421M4	24009344106
C0082M2	2113945B02	L0424M4	24009344106
C0083M2	2113945B02	L0428M4	24009344106
C0084M2	21667009166	L0434M4	24667008021
C0085M2	21667009166	L0500M3	24009344127
C0086M2	2113945C31	L0501M3	24009344128
C0087M2	2113946S35	L0502M3	24009344126
C0088M2	2113945Y02	L0503M3	24667008021
C0089M2	2113945Y02	L0504M3	24667008026
C0090M2	2113945B02	L0505M3	24667008026
C0091M2	2113944C82	L0507M3	24667008024
C0092M2	21667009166	L0700M6	24667008011
C0093M2	2113945Y02	L0701M6	24667008012
C0094M2	2113945Y02	L0702M6	24667008028
C0095M2	2113945A13	L0703M6	NOT PLACED
C0096M2	2113945B02	L0704M6	NOT PLACED
C0097M2	2113945B02	L0705M6	24667008007
C0098M2	21667009166	L0707M6	24667008028
C0099M2	2113945Y02	L0708M6	2479990G01
C0100M2	2113945Y02	L0709M6	NOT PLACED
C0101M2	21667009166	L0710M6	2485873L01
C0102M2	21667009166	L0711M6	NOT PLACED

Circuit Ref.	Motorola Solutions Part No.	Circuit Ref.	Motorola Solutions Part No.
C0103M2	21667009166	L0720M6	24667008014
C0104M2	21667009166	L0729M6	2414032B60
C0105M2	21667009166	L0730M6	24667008012
C0106M2	2113945B02	L0850M6	2460592A01
C0107M2	2113945B02	L0851M6	2460592A01
C0108M2	21667009166	L0852M6	2460592A01
C0109M2	2113945Y02	L0875M6	2460592A01
C0110M2	21667009381	L0876M6	24667008029
C0111M2	2113945Y02	L0877M6	2414032B49
C0112M2	21667009166	L0878M6	24667008024
C0113M2	21667009166	L0880M6	2414032B49
C0114M2	2113945Y02	L0885M6	24667008014
C0115M2	21667009370	L0900M6	NOT PLACED
C0116M2	NOT PLACED	L0901M6	NOT PLACED
C0117M2	21667009374	L0902M6	NOT PLACED
C0118M2	21667009375	L0950M6	24667008022
C0119M2	2113945A10	L0951M6	24009344022
C0120M2	21667009166	L0952M6	24009344006
C0121M2	NOT PLACED	M0700M6	2686201B02
C0122M2	21667009166	P0000M2	NOT PLACED
C0123M2	21667009381	P3000M6	09009344001
C0124M2	21667009166	Q0000M2	4813973A13
C0132M2	2113946J03	Q0001M2	48009494001
C0134M2	21667009166	Q0002M2	4813970A59
C0135M2	21667009166	Q0003M2	4885316E32
C0136M2	21667009166	Q0004M2	4815272H01
C0137M2	2113945Y02	Q0006M2	4813973A04
C0138M2	21667009166	Q0200M7	4885316E32
C0139M2	21667009166	Q0201M7	4885316E32
C0140M2	2113945Y02	Q0202M7	4815272H01
C0141M2	2113945Y02	Q0203M7	4815272H01
C0143M2	2113945Y02	Q0204M7	4885316E32
C0144M2	2113945Y02	Q0205M7	48009494001
C0145M2	21667009166	Q0206M7	4815272H01
C0146M2	2113945A10	Q0207M7	48009494001

Circuit Ref.	Motorola Solutions Part No.	Circuit Ref.	Motorola Solutions Part No.
C0147M2	2113945A10	Q0300M7	4802197J95
C0149M2	21667009166	Q0400M4	4815271H01
C0150M2	21667009166	Q0401M4	4815267H01
C0151M2	21667009368	Q0402M4	48012201001
C0200M7	21667009166	Q0403M4	4815270H01
C0201M7	NOT PLACED	Q0404M4	4815271H01
C0202M7	21667009166	Q0405M4	48012201001
C0203M7	NOT PLACED	Q0700M6	CR001114A01
C0204M7	NOT PLACED	Q0701M6	4816013H01
C0205M7	21667009274	Q0703M6	4802246J29
C0206M7	21667009366	Q0704M6	CR001116A01
C0207M7	21667009365	Q0705M6	CR001118A01
C0208M7	21667009311	Q0875M6	4813970A62
C0209M7	21667009311	Q0876M6	48009494001
C0210M7	21667009274	Q0900M6	NOT PLACED
C0211M7	NOT PLACED	Q0901M6	NOT PLACED
C0212M7	21667009294	Q3000M6	0105959T72
C0213M7	21667009274	Q3001M6	0105959T72
C0214M7	NOT PLACED	Q3002M6	4813973B01
C0215M7	21667009315	R0000M2	0613952R66
C0216M7	21667009311	R0001M2	0613952R66
C0217M7	21667009346	R0002M2	0613952Q96
C0218M7	21667009334	R0003M2	0613952Q57
C0219M7	21667009378	R0004M2	0613952Q34
C0220M7	21667009380	R0005M2	0613952R66
C0221M7	21667009371	R0006M2	0613952Q25
C0222M7	21667009366	R0007M2	0613952Q51
C0223M7	21667009370	R0008M2	0613952R01
C0224M7	21667009369	R0009M2	0613952Q58
C0225M7	2113945Y02	R0010M2	0613952R66
C0226M7	21667009311	R0011M2	0613952Q36
C0227M7	2113945Y02	R0012M2	0613952Q86
C0228M7	21667009166	R0013M2	0613952Q35
C0229M7	21667009166	R0014M2	0613952R66
C0230M7	21667009166	R0015M2	0613952R66

Circuit Ref.	Motorola Solutions Part No.	Circuit Ref.	Motorola Solutions Part No.
C0231M7	21667009166	R0018M2	0613952Q80
C0232M7	21667009166	R0019M2	0613952R01
C0233M7	21667009284	R0020M2	0613952R12
C0234M7	21667009315	R0021M2	0613952Q80
C0235M7	21667009166	R0022M2	0613952R66
C0236M7	2113945Y02	R0023M2	0613952Q83
C0237M7	21667009166	R0024M2	0613952Q80
C0238M7	2113945Y02	R0025M2	0613952R66
C0239M7	2113945Y02	R0026M2	0613952R66
C0240M7	21667009166	R0027M2	0613952R12
C0241M7	21667009166	R0028M2	0613952R66
C0242M7	21667009166	R0029M2	0613952Q25
C0243M7	21667009166	R0030M2	0613952R66
C0244M7	21667009332	R0031M2	0613952R66
C0245M7	21667009332	R0033M2	0613952R01
C0246M7	21667009166	R0034M2	0613952Q57
C0247M7	21667009166	R0040M2	0613952Q70
C0248M7	21667009326	R0041M2	0613952Q58
C0249M7	21667009166	R0042M2	0613952Q42
C0252M7	21667009339	R0043M2	0613952Q73
C0256M7	21667009371	R0044M2	0613952R25
C0257M7	21667009366	R0045M2	0613952R66
C0259M7	2113945Y02	R0046M2	0613952Q57
C0263M7	21667009166	R0051M2	0613952R01
C0265M7	21667009166	R0052M2	0613952R01
C0267M7	21667009297	R0054M2	0613952M25
C0269M7	21667009166	R0056M2	0613952R66
C0270M7	2113945Y02	R0058M2	0613952Q74
C0271M7	21667009166	R0059M2	0613952R66
C0272M7	2113945Y02	R0060M2	0613952Q89
C0276M7	21667009311	R0061M2	0613952Q85
C0300M7	NOT PLACED	R0062M2	0613952Q61
C0301M7	NOT PLACED	R0063M2	0613952Q64
C0302M7	21667009286	R0200M7	0613952R66
C0304M7	21667009390	R0201M7	0613952R27

Circuit Ref.	Motorola Solutions Part No.	Circuit Ref.	Motorola Solutions Part No.
C0305M7	2113945Y02	R0202M7	0613952R27
C0306M7	2113945B02	R0203M7	0613952R07
C0307M7	21667009390	R0204M7	0613952R05
C0308M7	2113945B02	R0205M7	0613952R07
C0309M7	21667009280	R0206M7	0613952R05
C0310M7	21667009279	R0207M7	0613952Q84
C0311M7	21667009346	R0208M7	0613952Q87
C0400M4	NOT PLACED	R0209M7	0613952Q85
C0402M4	21667009166	R0210M7	0613952Q79
C0403M4	21667009297	R0211M7	0613952Q18
C0404M4	21667009368	R0212M7	0613952Q32
C0405M4	21667009284	R0213M7	0613952Q67
C0406M4	21667009297	R0214M7	0613952Q67
C0407M4	21667009368	R0215M7	0613952Q67
C0408M4	2113945C31	R0216M7	0613952Q67
C0409M4	2113945C31	R0217M7	0613952Q49
C0410M4	21667009166	R0218M7	0613952Q49
C0411M4	21667009307	R0219M7	0613952R66
C0412M4	2113946F05	R0220M7	0613952R66
C0413M4	21667009166	R0221M7	0613952R66
C0414M4	21667009166	R0222M7	0613952Z41
C0415M4	21667009364	R0223M7	0613952Q73
C0416M4	2113945C31	R0224M7	0613952Z38
C0417M4	21667009166	R0225M7	0613952Q73
C0418M4	21667009415	R0226M7	0613952Q24
C0419M4	21667009274	R0227M7	0613952G67
C0420M4	21667009166	R0228M7	0613952Q67
C0421M4	21667009297	R0230M7	0613952Q67
C0422M4	21667009368	R0232M7	0613952Q49
C0423M4	21667009280	R0233M7	0613952R66
C0424M4	21667009297	R0300M7	0613952Q66
C0425M4	21667009368	R0301M7	0613952Q25
C0426M4	2113946F05	R0302M7	0613952Q66
C0427M4	21667009372	R0303M7	0613952R05
C0428M4	21667009284	R0304M7	0613952Q89

Circuit Ref.	Motorola Solutions Part No.	Circuit Ref.	Motorola Solutions Part No.
C0429M4	21667009280	R0305M7	0613952Q33
C0430M4	21667009161	R0306M7	0613952Q32
C0431M4	21667009368	R0307M7	0613952Q49
C0433M4	21667009166	R0308M7	0613952Q32
C0434M4	21667009384	R0309M7	0613952Q42
C0435M4	21667009380	R0400M4	0613952R01
C0436M4	21667009166	R0401M4	0613952H73
C0437M4	2113945C31	R0402M4	0613952R25
C0438M4	21667009166	R0403M4	0613952R01
C0439M4	21667009346	R0404M4	0613952R25
C0440M4	21667009315	R0405M4	0613952Q76
C0441M4	21667009372	R0406M4	0613952Q89
C0442M4	21667009277	R0407M4	0613952Q73
C0443M4	21667009364	R0408M4	0613952Q75
C0444M4	21667009286	R0409M4	0613952Q69
C0445M4	21667009368	R0410M4	0613952R01
C0446M4	21667009355	R0411M4	0613952R01
C0447M4	21667009277	R0412M4	0613952Q89
C0448M4	21667009372	R0413M4	0613958H59
C0449M4	21667009315	R0414M4	NOT PLACED
C0450M4	21667009388	R0415M4	0613952Q52
C0451M4	21667009166	R0416M4	0613952Q69
C0452M4	21667009366	R0417M4	0613952Q69
C0453M4	21667009366	R0418M4	0613952Q69
C0454M4	21667009366	R0419M4	0613952Q69
C0455M4	21667009366	R0420M4	0613952R25
C0456M4	21667009355	R0421M4	0613952R25
C0457M4	21667009339	R0422M4	0613952Q67
C0458M4	2113946F05	R0423M4	0613952R25
C0459M4	21667009307	R0424M4	0613952Q23
C0460M4	0613952R66	R0425M4	0613952Q67
C0461M4	NOT PLACED	R0426M4	0613952Q87
C0462M4	21667009159	R0427M4	0613952Q93
C0463M4	NOT PLACED	R0429M4	0613952R66
C0464M4	21667009158	R0430M4	NOT PLACED

Circuit Ref.	Motorola Solutions Part No.	Circuit Ref.	Motorola Solutions Part No.
C0465M4	21667009166	R0431M4	0613952R01
C0468M4	21667009166	R0432M4	0613952H73
C0469M4	21667009166	R0433M4	0613952R01
C0500M3	21667009369	R0434M4	0613952L46
C0501M3	21667009332	R0435M4	0613952L46
C0502M3	2113944M21	R0436M4	0613952R66
C0503M3	2113945C31	R0437M4	0613952Q77
C0504M3	2113945C31	R0438M4	0613958H25
C0505M3	21667011351	R0439M4	0613952Q83
C0506M3	NOT PLACED	R0440M4	0613958H25
C0507M3	21667009374	R0441M4	0613958H49
C0508M3	21667009366	R0442M4	0613952Q83
C0509M3	21667009382	R0443M4	0613952Q25
C0510M3	21667009366	R0444M4	0613952K25
C0511M3	21667009355	R0445M4	0613952Q75
C0512M3	21667009303	R0446M4	NOT PLACED
C0513M3	21667009368	R0447M4	0613952R66
C0515M3	21667009383	R0448M4	0613952Q35
C0516M3	21667011464	R0500M3	0613952Q87
C0517M3	21667009315	R0501M3	0613952R19
C0518M3	21667009339	R0502M3	0613952Q66
C0700M6	2113944C45	R0503M3	0613952Q88
C0701M6	21667009163	R0504M3	0613952Q61
C0702M6	2113944C41	R0505M3	0613952R66
C0703M6	2113944C42	R0525M3	0613952R66
C0704M6	NOT PLACED	R0700M6	0613952J05
C0705M6	NOT PLACED	R0701M6	0613952G67
C0706M6	NOT PLACED	R0702M6	0613952H89
C0707M6	2113944C82	R0703M6	0613952J01
C0708M6	NOT PLACED	R0704M6	0613952J06
C0709M6	2113945C04	R0705M6	0613952H48
C0710M6	21667009163	R0706M6	0613952H45
C0711M6	2113944C46	R0707M6	0613952H48
C0712M6	2113945C04	R0708M6	NOT PLACED
C0713M6	21667009163	R0709M6	0613952N43

Circuit Ref.	Motorola Solutions Part No.	Circuit Ref.	Motorola Solutions Part No.
C0715M6	NOT PLACED	R0710M6	0613952P01
C0716M6	2113944C55	R0711M6	0613958S44
C0717M6	2113944C39	R0712M6	0613958S44
C0718M6	NOT PLACED	R0713M6	NOT PLACED
C0719M6	NOT PLACED	R0714M6	0613958H15
C0720M6	2113944C42	R0715M6	0613958H15
C0721M6	2113944C82	R0716M6	0613958H15
C0722M6	2113944C34	R0717M6	0613958H15
C0723M6	2113945C04	R0718M6	0613952H96
C0724M6	2113944C39	R0719M6	0613952H89
C0725M6	2113944C39	R0720M6	0613952H95
C0726M6	2113944C51	R0721M6	0613952G67
C0727M6	NOT PLACED	R0722M6	0613952H29
C0729M6	NOT PLACED	R0723M6	0613952G67
C0730M6	NOT PLACED	R0724M6	NOT PLACED
C0731M6	21667009163	R0725M6	0613958S29
C0732M6	2113945A09	R0726M6	NOT PLACED
C0733M6	NOT PLACED	R0727M6	0613958S29
C0734M6	2113945A09	R0728M6	NOT PLACED
C0735M6	21667011073	R0729M6	NOT PLACED
C0737M6	2113944C51	R0730M6	NOT PLACED
C0738M6	21667009163	R0731M6	0613958S29
C0739M6	2113945C31	R0732M6	NOT PLACED
C0740M6	2113944C51	R0733M6	NOT PLACED
C0741M6	21667007037	R0734M6	0613958S29
C0742M6	2113945L49	R0735M6	NOT PLACED
C0743M6	21667007036	R0736M6	0613959Q25
C0744M6	21667007037	R0737M6	0613952F01
C0745M6	2113946J04	R0738M6	0613959Q32
C0746M6	NOT PLACED	R0739M6	0613952H73
C0747M6	NOT PLACED	R0740M6	NOT PLACED
C0748M6	NOT PLACED	R0741M6	0613952E66
C0749M6	21667007037	R0742M6	NOT PLACED
C0751M6	NOT PLACED	R0743M6	0613952E66
C0752M6	2111078B42	R0744M6	0613959Q32

Circuit Ref.	Motorola Solutions Part No.	Circuit Ref.	Motorola Solutions Part No.
C0753M6	2113944C51	R0745M6	0613952H29
C0754M6	2113944C45	R0746M6	0613952F01
C0755M6	2111078B42	R0759M6	0613959H12
C0756M6	2111078B22	R0849M6	0613952G67
C0757M6	2111078B22	R0876M6	0613958S73
C0758M6	2111078B27	R0877M6	0613959Y37
C0759M6	2111078B27	R0878M6	0613959Y37
C0760M6	2113944C45	R0879M6	0613952J25
C0761M6	2113944C45	R0882M6	0613952G67
C0762M6	2111078B26	R0883M6	0613952G67
C0763M6	2111078B26	R0902M6	0613952R66
C0764M6	2113944C51	R0903M6	0613952N01
C0765M6	NOT PLACED	R0904M6	0613952R66
C0766M6	NOT PLACED	R0905M6	0613952H42
C0767M6	2111078B06	R0906M6	0613958H46
C0768M6	2111078B07	R0907M6	0613958H55
C0769M6	NOT PLACED	R0908M6	NOT PLACED
C0770M6	NOT PLACED	R0909M6	NOT PLACED
C0771M6	NOT PLACED	R0910M6	NOT PLACED
C0772M6	NOT PLACED	R0911M6	NOT PLACED
C0789M6	2113944C39	R0912M6	0613958H46
C0790M6	21667007032	R0913M6	0613952M51
C0791M6	NOT PLACED	R0914M6	0613952M71
C0793M6	21667007019	R0915M6	NOT PLACED
C0794M6	21667007032	R0916M6	0613952R66
C0795M6	21667007018	R0917M6	0613952P01
C0796M6	2113944F07	R0919M6	0613952P01
C0797M6	2113944F07	R0920M6	0613952N01
C0798M6	2113944F07	R0921M6	0613952N01
C0799M6	2113944F07	R0922M6	0613952R66
C0800M6	21667007033	R0923M6	0613952M42
C0801M6	2113944F07	R0924M6	0613952N01
C0802M6	2113944F07	R0925M6	NOT PLACED
C0803M6	2113944F07	R0926M6	NOT PLACED
C0804M6	2113944F07	R0927M6	NOT PLACED

Circuit Ref.	Motorola Solutions Part No.	Circuit Ref.	Motorola Solutions Part No.
C0805M6	21667007033	R0928M6	0613952N81
C0808M6	NOT PLACED	R0929M6	0613952N85
C0812M6	21667007046	R0930M6	0613952N42
C0813M6	21667007046	R0931M6	0613952M66
C0814M6	21667007046	R0932M6	0613952N30
C0815M6	21667007046	R0933M6	0613952N01
C0816M6	NOT PLACED	R0934M6	0613952J17
C0818M6	NOT PLACED	R0935M6	0613952H91
C0822M6	2111078B11	R0936M6	NOT PLACED
C0824M6	2111078B17	R0937M6	NOT PLACED
C0841M6	NOT PLACED	R0938M6	NOT PLACED
C0842M6	NOT PLACED	R0939M6	0613952Z76
C0843M6	NOT PLACED	R0940M6	0613952R66
C0844M6	NOT PLACED	R0941M6	0613952N58
C0845M6	21667011411	R0942M6	0613952N58
C0846M6	21667011059	R0943M6	0613952N58
C0847M6	21667011059	R0950M6	0613952G67
C0848M6	2113944C45	R0951M6	0613958M18
C0849M6	2113944C39	R0952M6	0613958M18
C0850M6	2111078B05	R0953M6	0613952G67
C0851M6	2111078B21	R0954M6	0613952H56
C0852M6	2111078B08	R0955M6	0613952H56
C0853M6	2111078B16	R0956M6	0613952H67
C0854M6	2111078B15	R0957M6	0613958C25
C0855M6	2111078B08	R0958M6	0613958C25
C0856M6	2111078B42	R0959M6	0613952R66
C0875M6	2113944C42	R0960M6	0613952N58
C0876M6	NOT PLACED	R0961M6	0613952N58
C0877M6	2113944C42	R0962M6	0613952N58
C0878M6	NOT PLACED	R0965M6	NOT PLACED
C0879M6	2113944C42	R0966M6	NOT PLACED
C0880M6	21667011073	R3000M6	0613952H60
C0881M6	2111078B42	R3001M6	0615871H01
C0882M6	2111078B22	R3002M6	0615871H01
C0883M6	2111078B34	R3003M6	0615871H01

Circuit Ref.	Motorola Solutions Part No.	Circuit Ref.	Motorola Solutions Part No.
C0884M6	2113944F15	R3004M6	0615871H01
C0885M6	2113944C51	R3005M6	0613952H25
C0886M6	2113944C47	R3006M6	0613952H25
C0887M6	NOT PLACED	R3007M6	0613952M30
C0888M6	2113944C42	R3008M6	0613952G67
C0900M6	NOT PLACED	R3009M6	0613952M43
C0901M6	NOT PLACED	R3010M6	0613952G67
C0902M6	2113944C51	R3011M6	0613959Q60
C0905M6	2113945C31	R3012M6	0613959Q60
C0906M6	2113945A10	R3013M6	0613952R01
C0907M6	2113945L41	R3014M6	0613952R01
C0908M6	21667009166	R3015M6	0615871H01
C0909M6	NOT PLACED	R3018M6	0613952H73
C0910M6	NOT PLACED	R3019M6	0613952H60
C0911M6	2113944C02	R3020M6	0613952G67
C0912M6	NOT PLACED	R3021M6	0613952R25
C0913M6	21667009166	RT0900M6	0615585H01
C0916M6	NOT PLACED	SH0000M2	26012095001
C0917M6	21667009166	SH0001M2	26012095001
C0918M6	21667009166	SH0002M2	26012097001
C0919M6	21667009166	SH0003M2	26012094001
C0920M6	2113944C02	SH0004M2	26012094001
C0921M6	2113944C02	SH0200M7	26012095001
C0922M6	2113945C31	SH0300M7	26012095001
C0923M6	2113944C02	SH0400M4	26012096001
C0924M6	NOT PLACED	SH0401M4	26012096001
C0925M6	2113945C31	SH0402M4	26012098001
C0926M6	2113944C02	SH0403M4	26012098001
C0927M6	2113944C01	SH0500M3	26012098001
C0928M6	2113944C51	SH0501M3	NOT PLACED
C0929M6	2113944C49	SH0850M6	26012100001
C0930M6	NOT PLACED	SH0900M6	2686425Z02
C0950M6	2113944C47	SH0901M6	2686425Z02
C0951M6	21667011356	SP3000M6	NOT PLACED
C0952M6	2113944C47	SP3001M6	NOT PLACED

Circuit Ref.	Motorola Solutions Part No.	Circuit Ref.	Motorola Solutions Part No.
C0953M6	2113944C47	T0000M2	25012016001
C0954M6	21667011457	U0000M2	51009877001
C0955M6	2113944C47	U0001M2	5109731C48
C0956M6	2113944C01	U0002M2	4802197J95
C0957M6	2113944C49	U0200M7	5186310Y39
C3000M6	2113944C38	U0400M4	HZ000490A01
C3001M6	2113944C06	U0500M3	4802197J95
C3002M6	2113944C06	U0901M6	5180390L83
C3003M6	2113945C31	U0902M6	51012221001
C3004M6	2113945C02	U0903M6	5115022H01
C3005M6	2113945C02	U0904M6	5109731C48
C3008M6	2113944C51	U0905M6	5109731C48
C3009M6	2113945C31	U3000M6	5116525H01
C3010M6	2113944C46	U3001M6	4813973M07
C3011M6	NOT PLACED	U3002M6	51012133001
C3012M6	2113946J04	VR0001M2	4815096H01
C3013M6	2113945C31	VR0200M7	CR000291A01
C3014M6	21009337414	VR0201M7	CR000291A01
C3015M6	2113946G01	VR0202M7	CR000291A01
C3016M6	2113945C31	VR0203M7	CR000291A01
C3019M6	2113946S35	VR0204M7	CR000291A01
C3020M6	2113945C26	VR0205M7	CR000291A01
C3021M6	2113944C06	VR0206M7	CR000291A01
C3022M6	2113945A10	VR0207M7	CR000291A01
C3029M6	NOT PLACED	VR0208M7	CR000291A01
C3038M6	21667009379	VR0209M7	CR000291A01
C3041M6	21667009379	VR0210M7	CR000291A01
C3042M6	21667009379	VR0211M7	CR000291A01
C3044M6	21667009379	VR0214M7	CR000291A01
C3046M6	NOT PLACED	VR0215M7	CR000291A01
C3047M6	NOT PLACED	VR0400M4	CR000291A01
C3048M6	NOT PLACED	VR0401M4	CR000291A01
C3049M6	NOT PLACED	VR0402M4	CR000291A01
D0000M2	4815011H01	VR0403M4	CR000291A01
D0001M2	4815011H01	VR0404M4	CR000291A01

Circuit Ref.	Motorola Solutions Part No.	Circuit Ref.	Motorola Solutions Part No.
D0400M4	4884800Y03	VR0405M4	CR000291A01
D0401M4	4813974A19	VR0406M4	CR000291A01
D0402M4	4813974A19	VR0407M4	CR000291A01
D0403M4	4884800Y03	VR3000M6	48012202001
D0500M3	4813974A19	VR3002M6	4813977M10
D0700M6	NOT PLACED	Y0000M2	4875185M05
D0875M6	48012160001	-	-



NOTICE: The suffix "M1", "M2", and so on from the Circuit Ref. is removed from the schematic and overlays.

8.7

UHF2 Service Information

8.7.1

Allocation of Schematics and Circuit Boards

This chapter shows the schematics for the UHF2 circuits. The PCB component layouts and the Parts List in this chapter show both the Controller and UHF2 circuit components.

UHF2 Schematic Diagrams and Parts List for 84012728001-A

Diagrams:

- [Figure 224: Main Board Top Side PCB No. 84012728001-A on page 461](#)
- [Figure 225: Main Board Bottom Side PCB No. 84012728001-A on page 462](#)
- [Figure 226: Overall Schematic Diagram on page 463](#)
- [Figure 227: Receiver Front-End Schematic Diagram on page 464](#)
- [Figure 228: Receiver IF Amp Schematic Diagram on page 465](#)
- [Figure 229: Transmitter Power Amplifier Schematic Diagram \(Sheet 1 of 3\) on page 466](#)
- [Figure 230: Transmitter Power Amplifier Schematic Diagram \(Sheet 2 of 3\) on page 467](#)
- [Figure 231: Transmitter Power Amplifier Schematic Diagram \(Sheet 3 of 3\) on page 468](#)
- [Figure 232: Power Control Schematic Diagram on page 469](#)
- [Figure 233: Transmitter Power Amplifier DC Distribution Schematic Diagram on page 470](#)
- [Figure 234: RFIC Schematic Diagram on page 471](#)
- [Figure 235: Receiver VCO Schematic Diagram on page 472](#)
- [Figure 236: Transmit VCO Schematic Diagram on page 473](#)
- [Figure 237: VCO Buffer Schematic Diagram on page 474](#)

[Parts List for 84012728001-A on page 475](#)

UHF2 Schematic Diagrams and Parts List for 84012728003-C

Diagrams:

- [Figure 238: Main Board Top Side PCB No. 84012728003-C on page 502](#)
- [Figure 239: Main Board Bottom Side PCB No. 84012728003-C on page 503](#)
- [Figure 240: Overall Schematic Diagram on page 504](#)
- [Figure 241: Receiver Front-End Schematic Diagram on page 505](#)
- [Figure 242: Receiver IF Amp Schematic Diagram on page 506](#)
- [Figure 243: Transmit Power Amplifier Schematic Diagram \(Sheet 1 of 3\) on page 507](#)
- [Figure 244: Transmit Power Amplifier Schematic Diagram \(Sheet 2 of 3\) on page 508](#)
- [Figure 245: Transmit Power Amplifier Schematic Diagram \(Sheet 3 of 3\) on page 509](#)
- [Figure 246: Power Control Schematic Diagram on page 510](#)
- [Figure 247: Transmit Power Amplifier DC Distribution Schematic Diagram on page 511](#)
- [Figure 248: RFIC Schematic Diagram on page 512](#)
- [Figure 249: Receiver VCO Schematic Diagram on page 513](#)
- [Figure 250: Transmit VCO Schematic Diagram on page 514](#)
- [Figure 251: VCO Buffer Schematic Diagram on page 515](#)

[Parts List for 84012728003-C on page 516](#)

8.7.1.1

Circuit Board and Schematic Diagrams for 84012728001-A

Figure 224: Main Board Top Side PCB No. 84012728001-A

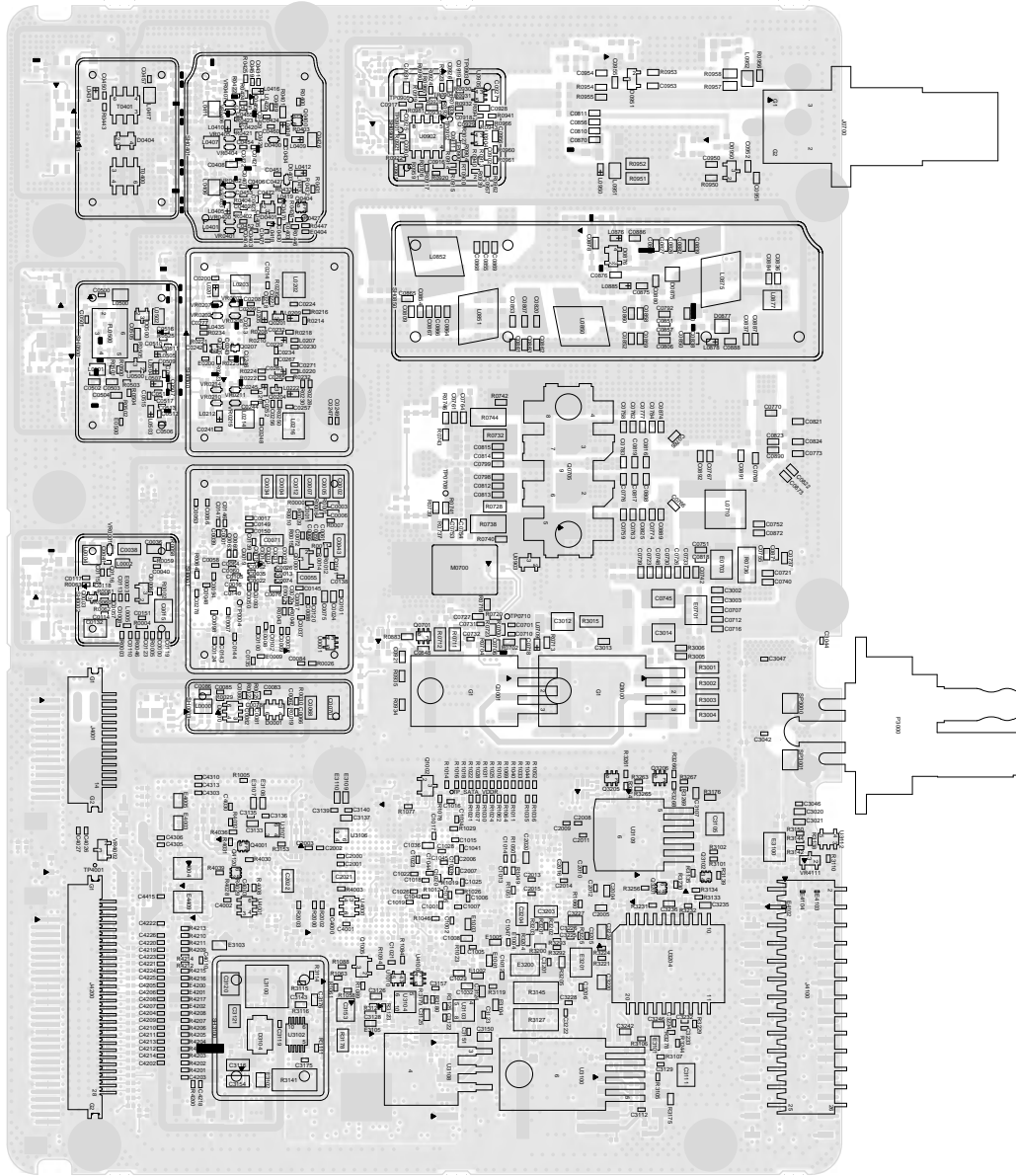

Figure 225: Main Board Bottom Side PCB No. 84012728001-A

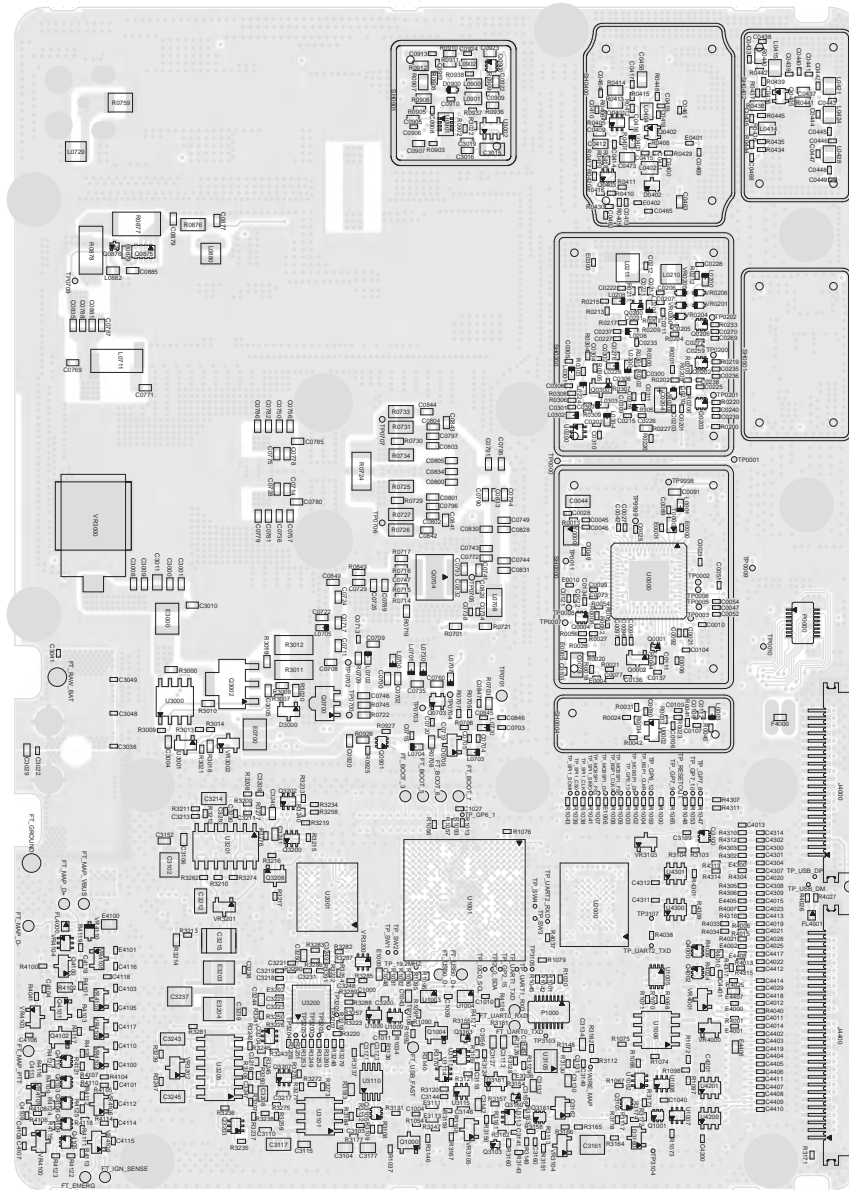

Figure 226: Overall Schematic Diagram

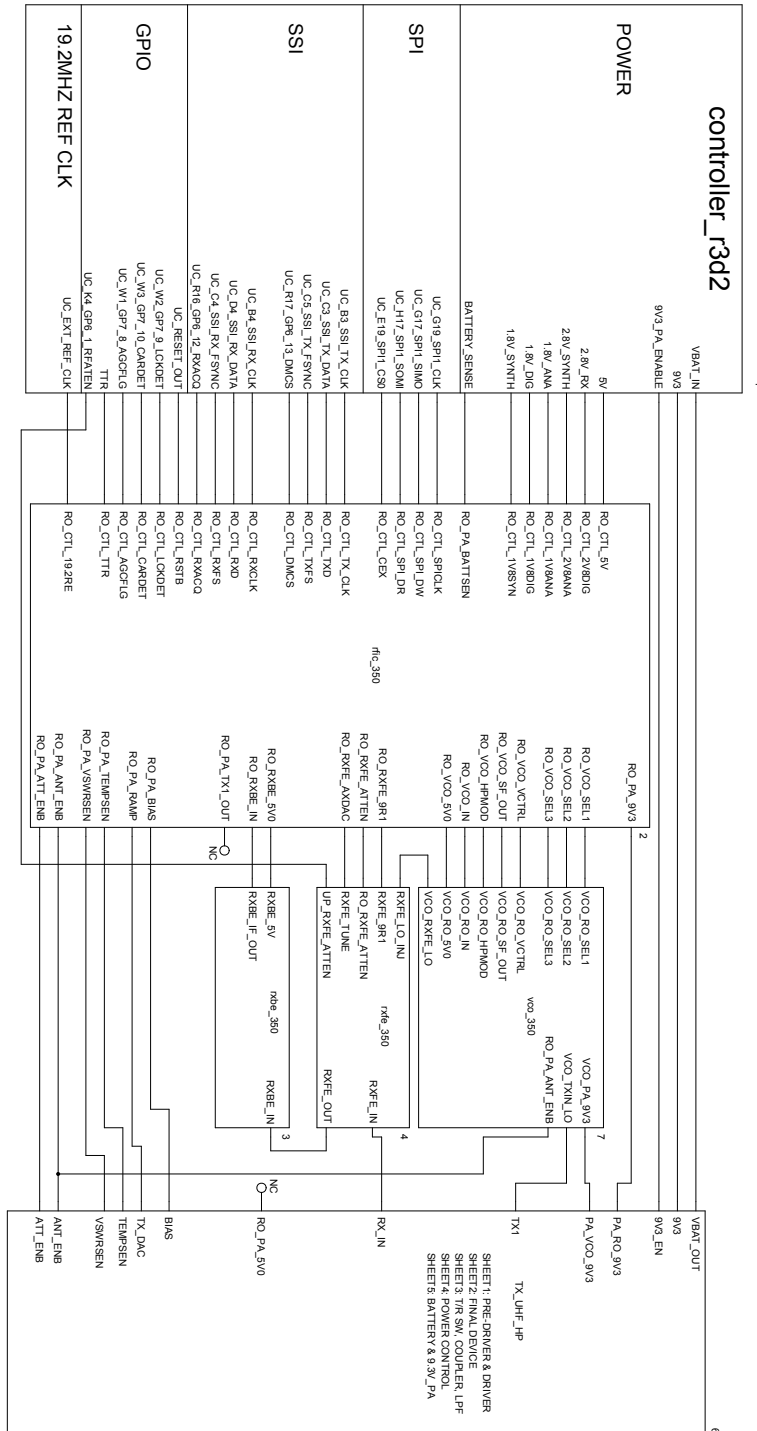

Figure 227: Receiver Front-End Schematic Diagram

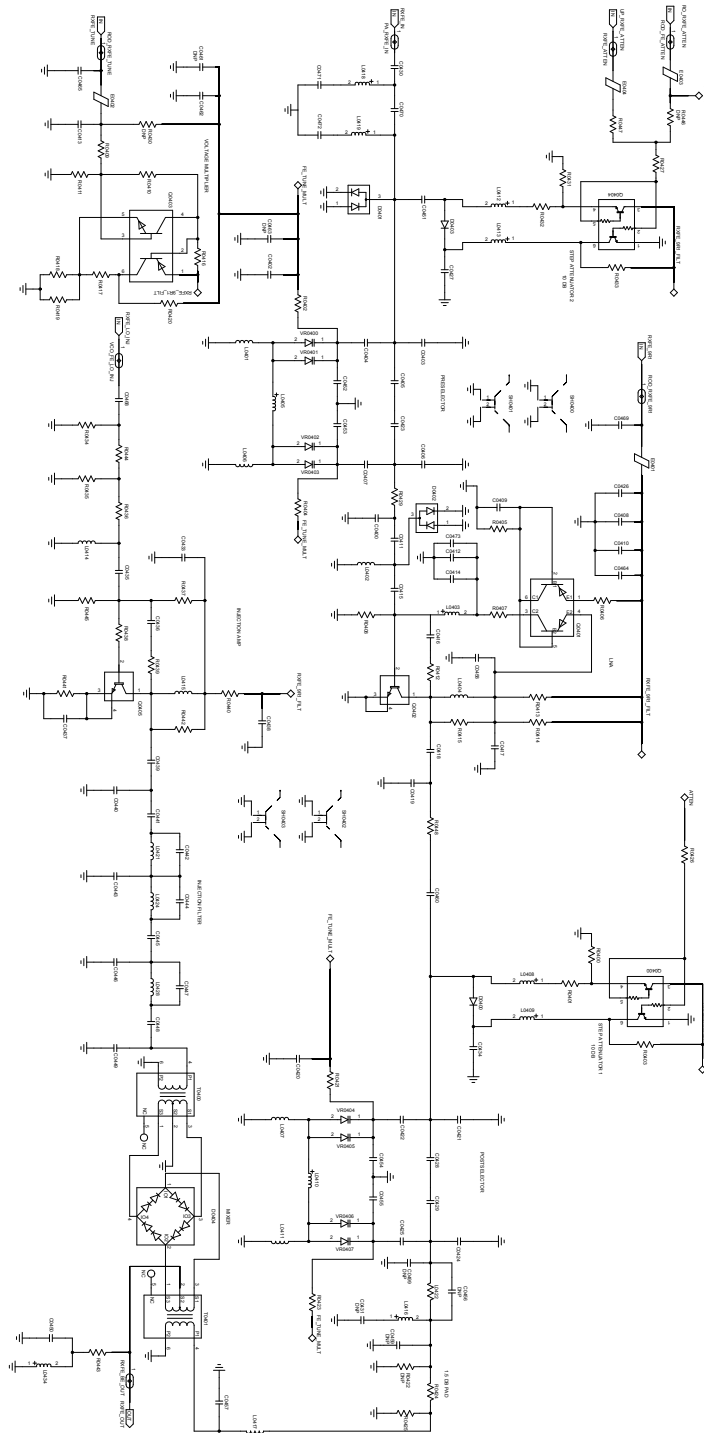

Figure 228: Receiver IF Amp Schematic Diagram

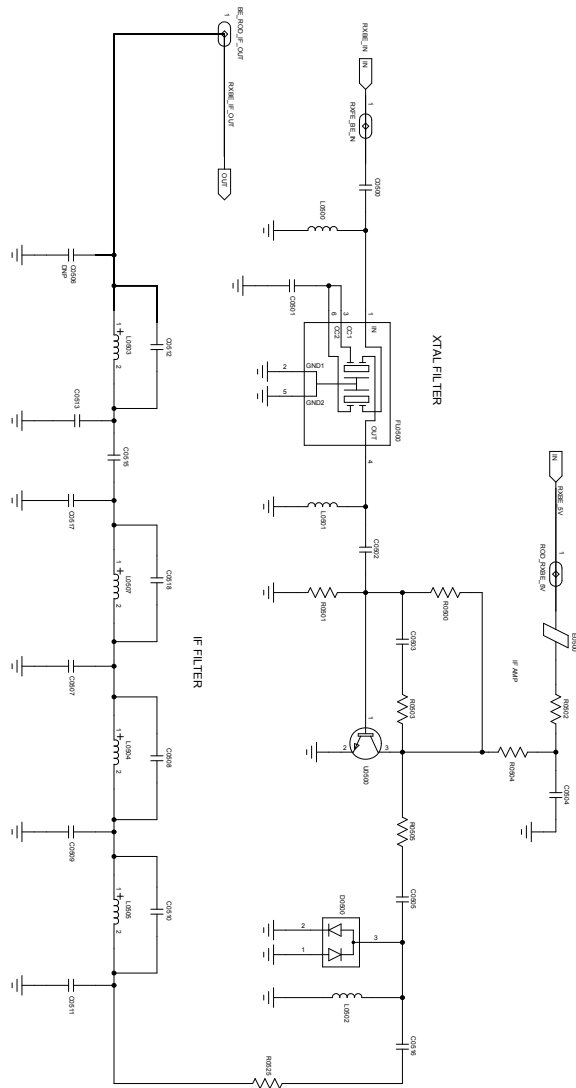
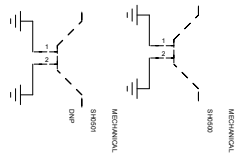

Figure 230: Transmitter Power Amplifier Schematic Diagram (Sheet 2 of 3)

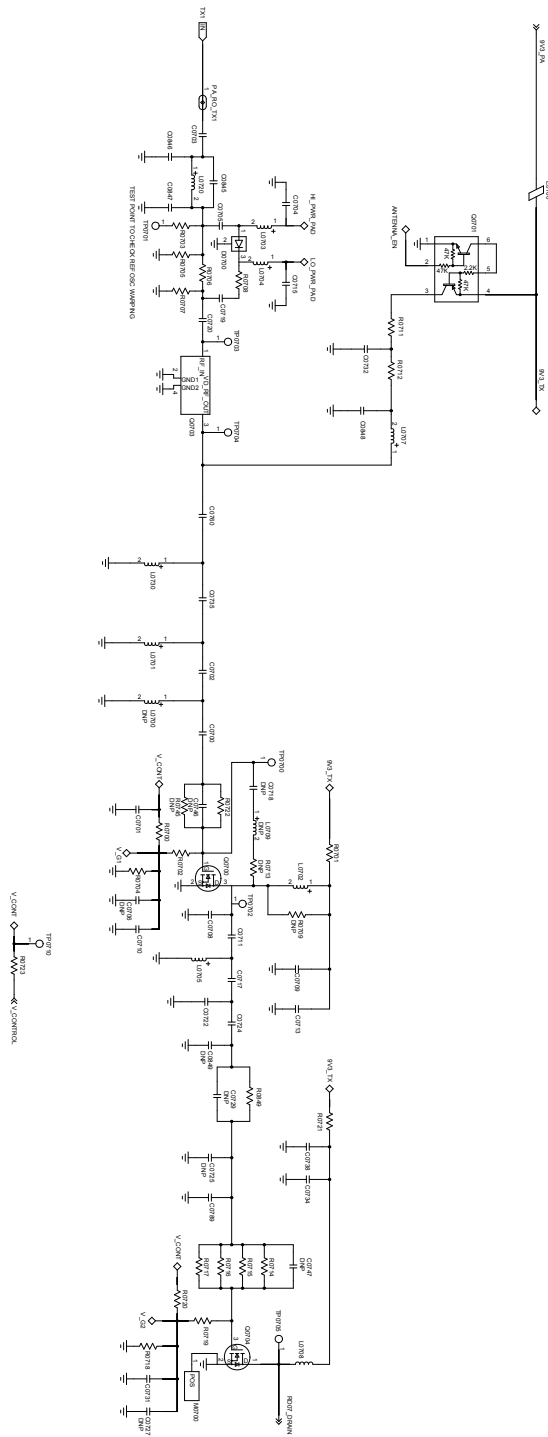

Figure 231: Transmitter Power Amplifier Schematic Diagram (Sheet 3 of 3)

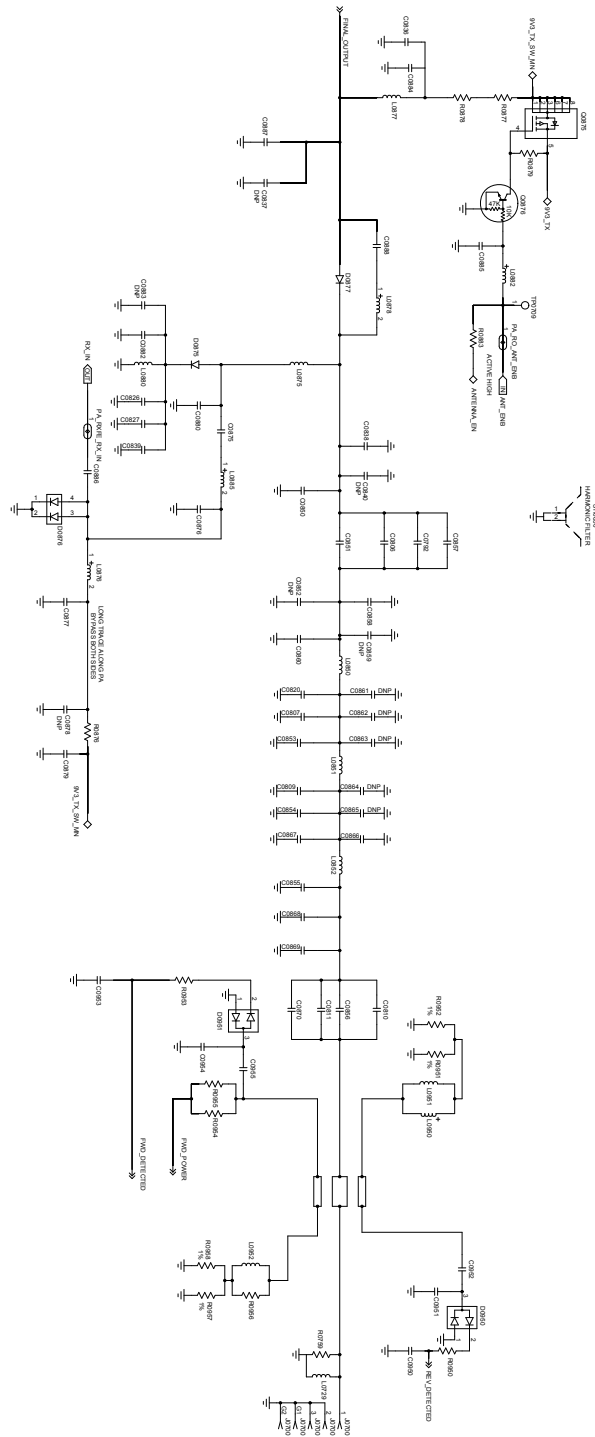

Figure 233: Transmitter Power Amplifier DC Distribution Schematic Diagram

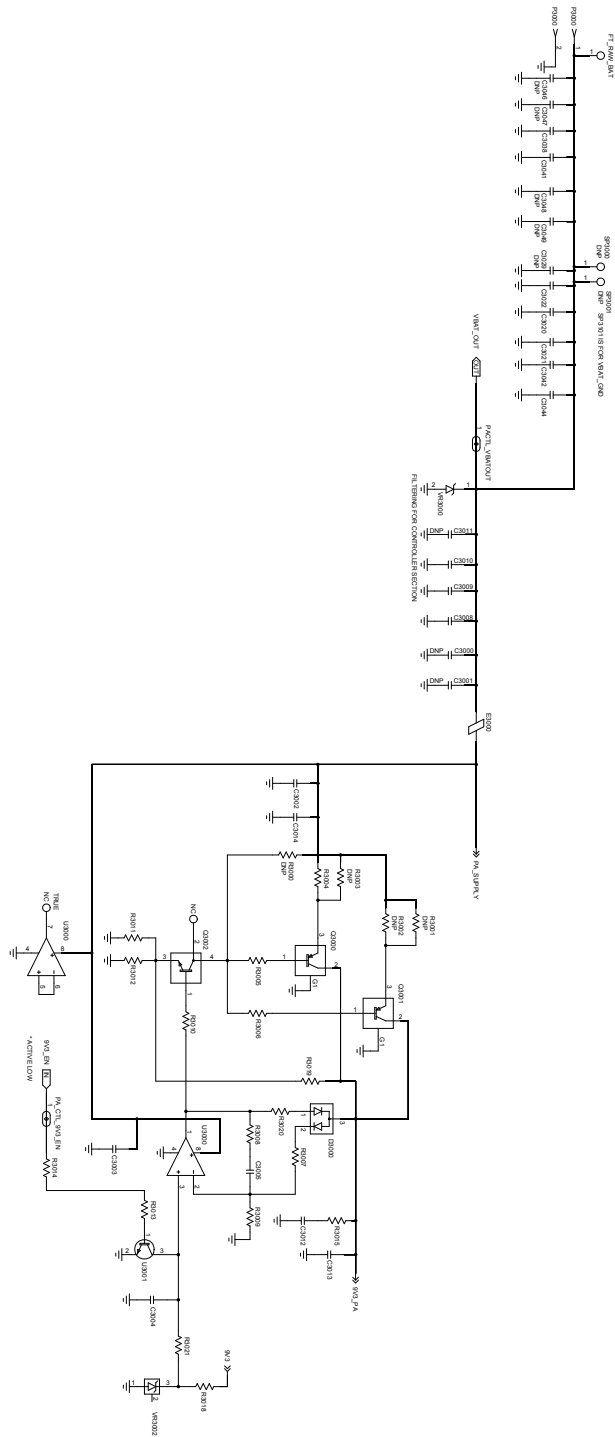

Figure 235: Receiver VCO Schematic Diagram

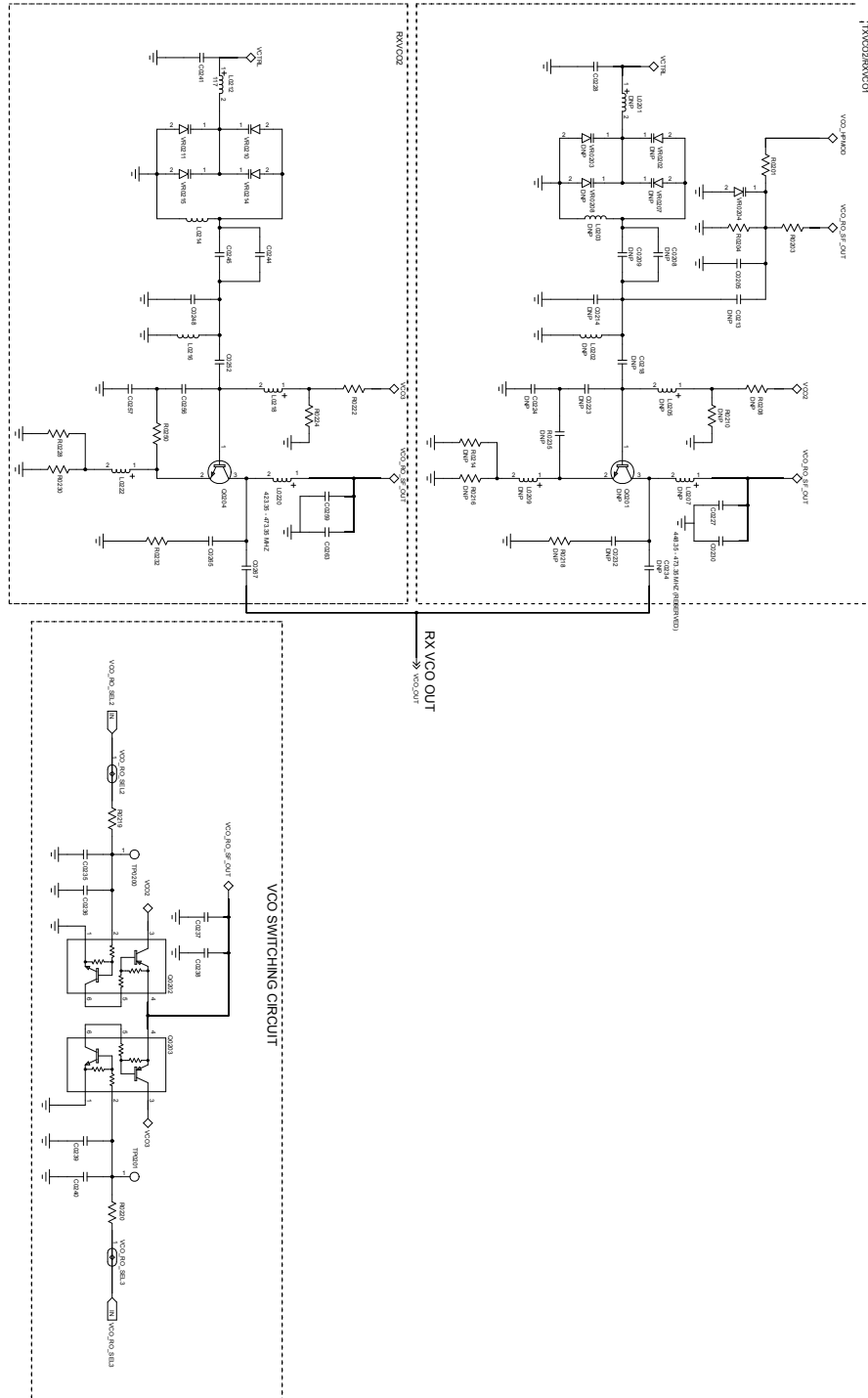

Figure 236: Transmit VCO Schematic Diagram

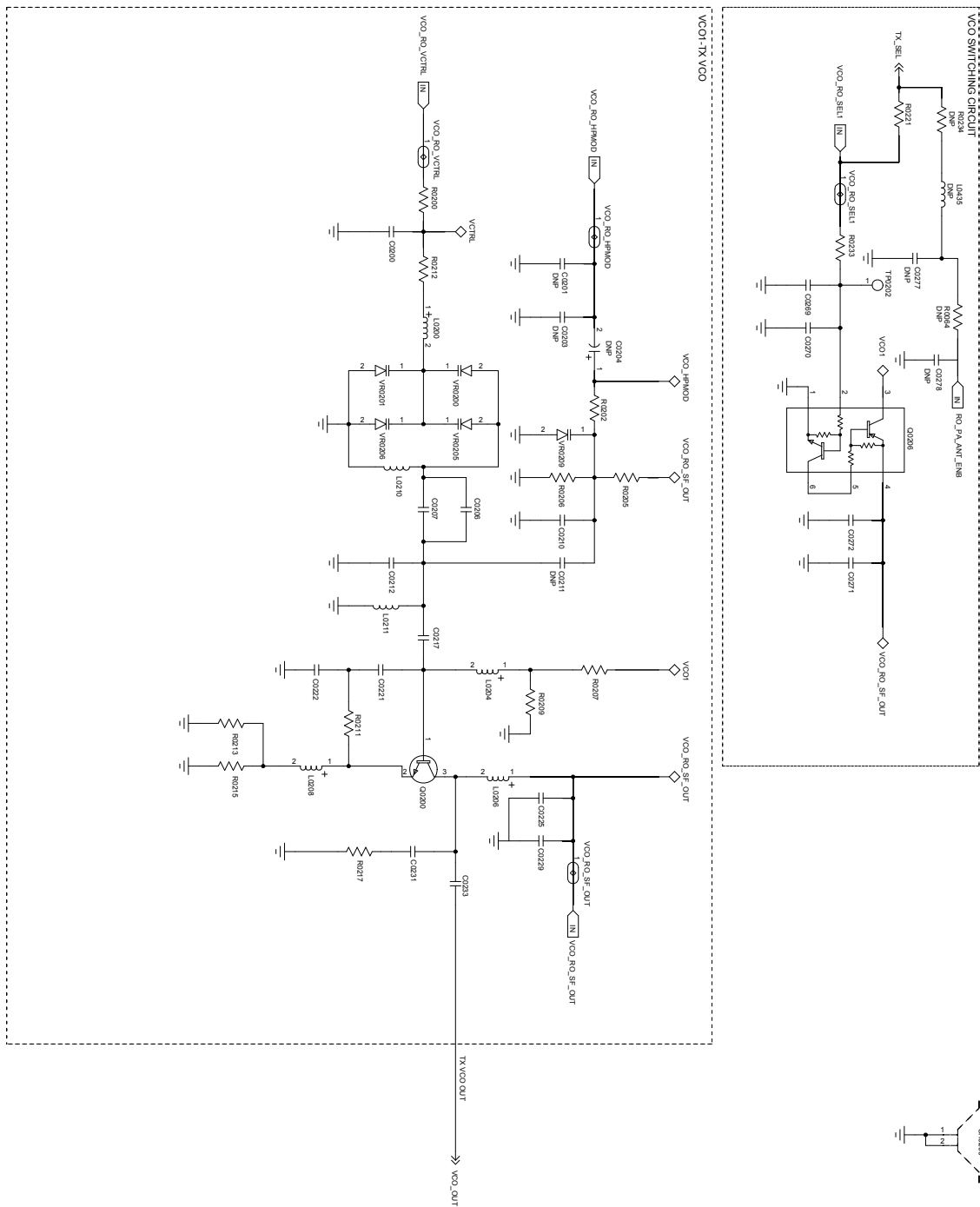
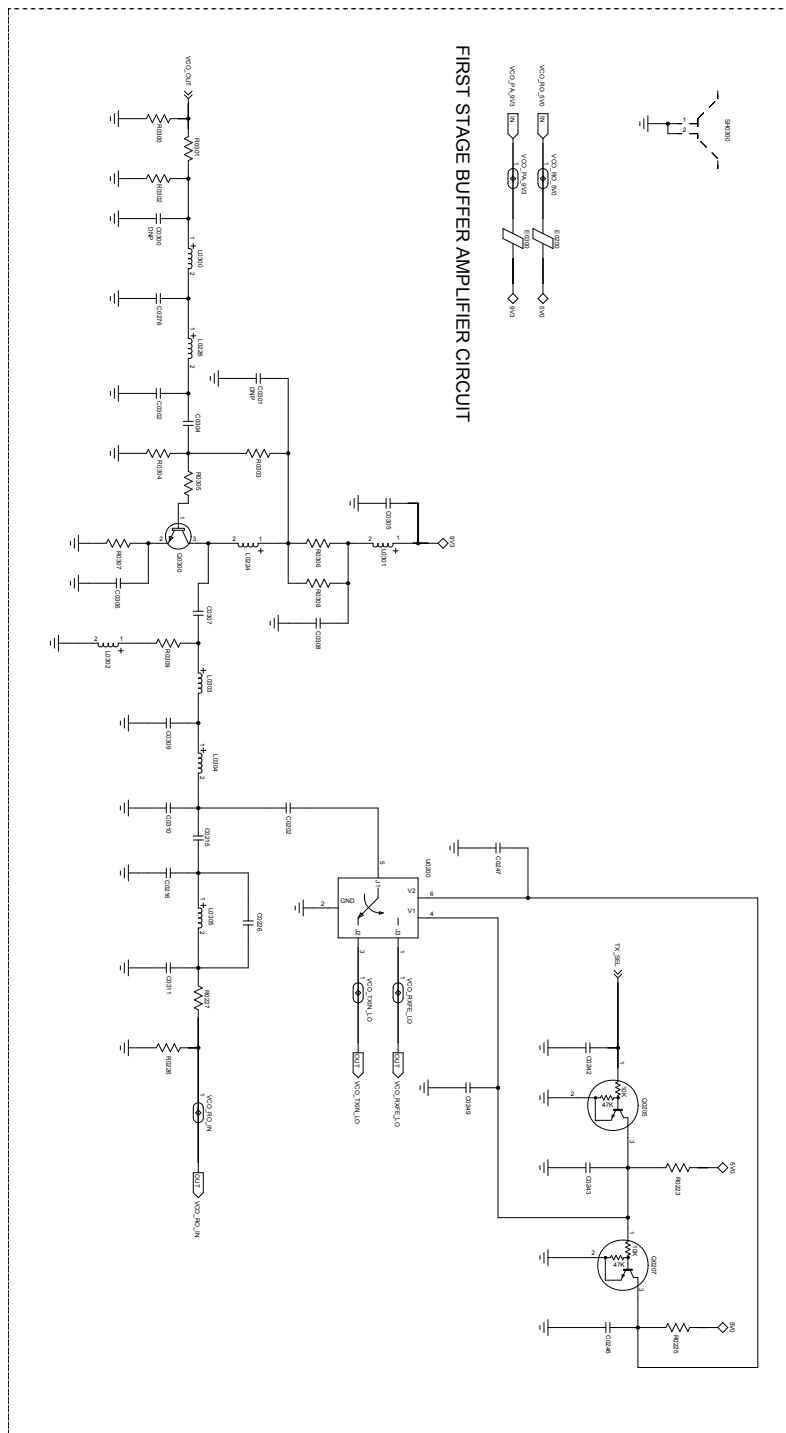

Figure 237: VCO Buffer Schematic Diagram



8.7.1.2

Parts List for 84012728001-A

Table 25: UHF2 Radio Parts List

Circuit Ref.	Motorola Solutions Part No.	Circuit Ref.	Motorola Solutions Part No.
C0000M2	21667009311	L0203M7	24009343013
C0001M2	21667009170	L0204M7	24667001031
C0002M2	NOT PLACED	L0205M7	24667001031
C0003M2	NOT PLACED	L0206M7	24667001031
C0004M2	21012044001	L0207M7	24667001031
C0005M2	21012044001	L0208M7	24667001031
C0006M2	2113945C31	L0209M7	24667001031
C0007M2	21012044001	L0210M7	24009343008
C0008M2	21667009311	L0211M7	2415385H01
C0009M2	21667009166	L0212M7	24667001031
C0010M2	21667009166	L0214M7	24009343008
C0011M2	2113945C31	L0216M7	2415385H01
C0012M2	21012044001	L0218M7	24667001031
C0013M2	2113945Y02	L0220M7	24667001031
C0014M2	2113945Y02	L0222M7	24667001031
C0015M2	2113946J03	L0224M7	24667001030
C0016M2	2113945A10	L0226M7	24667001018
C0017M2	2113945Y02	L0300M7	24667001017
C0018M2	2113945A10	L0301M7	24667001031
C0019M2	2113945Y02	L0302M7	24667001031
C0020M2	2113945A10	L0303M7	24667001021
C0021M2	2113945Y02	L0304M7	24667001017
C0022M2	2113945Y02	L0305M7	24667001013
C0023M2	2113945Y02	L0401M4	24012021001
C0024M2	21012129001	L0402M4	24009344102
C0025M2	21667009166	L0403M4	24667001030
C0026M2	2113944A52	L0404M4	24009344109
C0027M2	2113945Y02	L0405M4	24009315036
C0028M2	2113945Y02	L0406M4	24012021001
C0029M2	2113945A10	L0407M4	24012021001
C0030M2	2113945A10	L0408M4	24667001030
C0031M2	2113945Y02	L0409M4	24667001030

Circuit Ref.	Motorola Solutions Part No.	Circuit Ref.	Motorola Solutions Part No.
C0032M2	21667009166	L0410M4	24667001025
C0034M2	21012044001	L0411M4	24012021001
C0035M2	21667009166	L0412M4	24667001030
C0036M2	21012025001	L0413M4	24667001030
C0037M2	21667009166	L0414M4	24009344105
C0038M2	21012044001	L0415M4	24009344106
C0039M2	2113945Y02	L0416M4	24667001014
C0040M2	2113945A10	L0417M4	24009344109
C0041M2	21667009364	L0418M4	NOT PLACED
C0042M2	21667009166	L0419M4	NOT PLACED
C0043M2	21012044001	L0421M4	24009344105
C0044M2	2113955D45	L0422M4	NOT PLACED
C0045M2	2113945Y02	L0424M4	24009344105
C0046M2	21667009166	L0428M4	24009344105
C0047M2	21667009166	L0434M4	24667001021
C0048M2	21667009166	L0435M7	NOT PLACED
C0049M2	2113945B02	L0500M3	24009344127
C0050M2	21667009166	L0501M3	24009344128
C0051M2	21667009166	L0502M3	24009344126
C0052M2	21667009166	L0503M3	24667001021
C0053M2	21667009166	L0504M3	24667001026
C0054M2	21667009166	L0505M3	24667001026
C0055M2	2113955D37	L0507M3	24667001024
C0056M2	2113945Y02	L0700M6	NOT PLACED
C0057M2	2113945B02	L0701M6	24667001014
C0058M2	NOT PLACED	L0702M6	24667001028
C0059M2	21667009166	L0703M6	24667001028
C0060M2	2113945A69	L0704M6	24667001028
C0061M2	2113945Y02	L0705M6	24667001007
C0062M2	NOT PLACED	L0707M6	24667001028
C0063M2	NOT PLACED	L0708M6	2479990G01
C0064M2	2113945A69	L0709M6	NOT PLACED
C0065M2	2113945Y02	L0710M6	2485873L01
C0066M2	2113945B02	L0711M6	NOT PLACED
C0067M2	2113945Y02	L0720M6	24667001013

Circuit Ref.	Motorola Solutions Part No.	Circuit Ref.	Motorola Solutions Part No.
C0068M2	2113955D37	L0729M6	2414032B60
C0069M2	NOT PLACED	L0730M6	24667001013
C0070M2	2113955D37	L0850M6	2460592A01
C0071M2	2113955D37	L0851M6	2460592A01
C0072M2	21667009166	L0852M6	2460592A01
C0073M2	21667009166	L0875M6	2460592A01
C0074M2	21667009166	L0876M6	24667001029
C0075M2	2113946S35	L0877M6	2414032B49
C0076M2	2113946S35	L0878M6	24667001027
C0077M2	21667009166	L0880M6	2414032B49
C0078M2	21667009372	L0882M6	24667001027
C0079M2	2113955D37	L0885M6	24667001014
C0080M2	2113945B02	L0900M6	24667000031
C0081M2	2113945B02	L0901M6	24009344018
C0082M2	2113945B02	L0902M6	24667000031
C0083M2	2113945B02	L0950M6	NOT PLACED
C0084M2	21667009166	L0951M6	24009344003
C0085M2	21667009166	L0952M6	24009344005
C0086M2	2113945C31	L3100M1	24012091002
C0087M2	2113946S35	M0700M6	2686201B02
C0088M2	2113945Y02	P0000M2	NOT PLACED
C0089M2	2113945Y02	P1000M1	2887818K02
C0090M2	2113945B02	P3000M6	09009344001
C0091M2	2113944C82	PASTE1	BU000032A01
C0092M2	21667009166	PASTE2	BU000032A01
C0093M2	2113945Y02	PASTE3	BU000032A01
C0094M2	2113945Y02	PASTE4	BU000032A01
C0095M2	2113945A13	PASTE5	BU000032A01
C0096M2	2113945B02	PASTE6	BU000032A01
C0097M2	2113945B02	PCB	84012728001
C0098M2	21667009166	Q0000M2	4813973A13
C0099M2	2113945Y02	Q0001M2	48009494001
C0100M2	2113945Y02	Q0002M2	4813970A59
C0101M2	21667009166	Q0003M2	4885061Y01
C0102M2	21667009166	Q0004M2	4815272H01

Circuit Ref.	Motorola Solutions Part No.	Circuit Ref.	Motorola Solutions Part No.
C0103M2	21667009166	Q0006M2	4813973A04
C0104M2	21667009166	Q0200M7	4885061Y01
C0105M2	21667009166	Q0201M7	4885061Y01
C0106M2	2113945B02	Q0202M7	4815272H01
C0107M2	2113945B02	Q0203M7	4815272H01
C0108M2	21667009166	Q0204M7	4885061Y01
C0109M2	2113945Y02	Q0205M7	48009494001
C0110M2	21667009381	Q0206M7	4815272H01
C0111M2	2113945Y02	Q0207M7	48009494001
C0112M2	21667009166	Q0300M7	4802197J95
C0113M2	21667009166	Q0400M4	4815271H01
C0114M2	2113945Y02	Q0401M4	4815267H01
C0115M2	21667009370	Q0402M4	4815118H01
C0116M2	NOT PLACED	Q0403M4	4815270H01
C0117M2	21667009374	Q0404M4	4815271H01
C0118M2	21667009375	Q0405M4	4815118H01
C0119M2	2113945A10	Q0700M6	4816547H01
C0120M2	21667009166	Q0701M6	4816013H01
C0121M2	NOT PLACED	Q0703M6	4802246J29
C0122M2	21667009166	Q0704M6	4816548H01
C0123M2	21667009381	Q0705M6	48012022001
C0124M2	21667009166	Q0875M6	4813970A62
C0132M2	2113946J03	Q0876M6	4816134H01
C0134M2	21667009166	Q0900M6	4815272H01
C0135M2	21667009166	Q0901M6	4815271H01
C0136M2	21667009166	Q1000M1	4815263H01
C0137M2	2113945Y02	Q1001M1	4815272H01
C0138M2	21667009166	Q1002M1	4815261H01
C0139M2	21667009166	Q1004M1	4815261H01
C0140M2	2113945Y02	Q1005M1	4815261H01
C0141M2	2113945Y02	Q3000M6	0105959T72
C0143M2	2113945Y02	Q3001M6	0105959T72
C0144M2	2113945Y02	Q3002M6	4813973B01
C0145M2	21667009166	Q3100M1	4815272H01
C0146M2	2113945A10	Q3101M1	4809939C47

Circuit Ref.	Motorola Solutions Part No.	Circuit Ref.	Motorola Solutions Part No.
C0147M2	2113945A10	Q3102M1	4809939C47
C0149M2	21667009166	Q3103M1	48009494001
C0150M2	21667009166	Q3105M1	4809939C47
C0151M2	21667009368	Q3160M1	48009494001
C0200M7	21667009166	Q3161M1	4815272H01
C0201M7	NOT PLACED	Q3162M1	4813973M07
C0202M7	21667009166	Q3163M1	48009494001
C0203M7	NOT PLACED	Q3200M1	4815270H01
C0204M7	NOT PLACED	Q3201M1	4815272H01
C0205M7	21667009274	Q3202M1	4815270H01
C0206M7	21667009320	Q3203M1	4815270H01
C0207M7	21667009320	Q3204M1	4815270H01
C0208M7	21667009303	Q3205M1	4815270H01
C0209M7	21667009297	Q3206M1	4815270H01
C0210M7	NOT PLACED	Q3207M1	4815270H01
C0211M7	NOT PLACED	Q3208M1	4815263H01
C0212M7	21667009286	Q4000M1	4809939C47
C0213M7	21667009274	Q4001M1	4809939C47
C0214M7	21667009303	Q4002M1	4809939C47
C0215M7	21667009332	Q4100M1	4816023H01
C0216M7	21667009303	Q4101M1	4815261H01
C0217M7	21667009332	Q4102M1	4815263H01
C0218M7	21667009320	Q4103M1	48012271001
C0221M7	21667009371	Q4105M1	48012271001
C0222M7	21667009366	Q4106M1	48012271001
C0223M7	21667009372	Q4109M1	48012271001
C0224M7	21667009366	Q4112M1	48012271001
C0225M7	2113945Y02	Q4120M1	4809939C47
C0226M7	21667009311	R0000M2	0613952R66
C0227M7	2113945Y02	R0001M2	0613952R66
C0228M7	21667009166	R0002M2	0613952Q96
C0229M7	21667009166	R0003M2	0613952Q57
C0230M7	21667009166	R0004M2	0613952Q34
C0231M7	21667009166	R0005M2	0613952R66
C0232M7	21667009166	R0006M2	0613952Q25

Circuit Ref.	Motorola Solutions Part No.	Circuit Ref.	Motorola Solutions Part No.
C0233M7	21667009284	R0007M2	0613952Q54
C0234M7	21667009284	R0008M2	0613952R01
C0235M7	21667009166	R0009M2	0613952Q58
C0236M7	2113945Y02	R0010M2	0613952R66
C0237M7	21667009166	R0011M2	0613952Q36
C0238M7	2113945Y02	R0012M2	0613952Q86
C0239M7	2113945Y02	R0013M2	0613952Q35
C0240M7	21667009166	R0014M2	0613952R66
C0241M7	21667009166	R0015M2	0613952R66
C0242M7	21667009166	R0018M2	0613952Q80
C0243M7	21667009166	R0019M2	0613952R01
C0244M7	21667009297	R0020M2	0613952R12
C0245M7	21667009291	R0021M2	0613952Q80
C0246M7	21667009166	R0022M2	0613952R66
C0247M7	21667009166	R0023M2	0613952Q83
C0248M7	21667009364	R0024M2	0613952Q80
C0249M7	21667009166	R0025M2	0613952R66
C0252M7	21667009320	R0026M2	0613952R66
C0256M7	21667009374	R0027M2	0613952R12
C0257M7	21667009370	R0028M2	0613952R66
C0259M7	2113945Y02	R0029M2	0613952Q25
C0263M7	21667009166	R0030M2	0613952R66
C0265M7	21667009166	R0031M2	0613952R66
C0267M7	21667009284	R0033M2	0613952R01
C0269M7	21667009166	R0034M2	0613952Q57
C0270M7	2113945Y02	R0040M2	0613952Q70
C0271M7	21667009166	R0041M2	0613952Q58
C0272M7	2113945Y02	R0042M2	0613952Q42
C0276M7	21667009332	R0043M2	0613952Q73
C0277M7	NOT PLACED	R0044M2	0613952R25
C0278M7	NOT PLACED	R0045M2	0613952R66
C0300M7	21667009303	R0046M2	0613952Q57
C0301M7	NOT PLACED	R0051M2	0613952R01
C0302M7	21667009303	R0052M2	0613952R01
C0304M7	21667009390	R0054M2	0613952M25

Circuit Ref.	Motorola Solutions Part No.	Circuit Ref.	Motorola Solutions Part No.
C0305M7	2113945Y02	R0056M2	0613952R66
C0306M7	2113945B02	R0058M2	0613952Q74
C0307M7	21667009390	R0059M2	0613952R66
C0308M7	2113945B02	R0060M2	0613952Q86
C0309M7	21667009297	R0061M2	0613952Q85
C0310M7	21667009282	R0062M2	0613952Q61
C0311M7	21667009364	R0063M2	0613952Q64
C0400M4	21667009005	R0064M7	NOT PLACED
C0402M4	21667009166	R0200M7	0613952R66
C0403M4	21667009274	R0201M7	0613952R27
C0404M4	21667009332	R0202M7	NOT PLACED
C0405M4	21667009005	R0203M7	0613952R07
C0406M4	21667009274	R0204M7	0613952R05
C0407M4	21667009332	R0205M7	NOT PLACED
C0408M4	2113945C31	R0206M7	NOT PLACED
C0409M4	2113945C31	R0207M7	0613952Q84
C0410M4	21667009166	R0208M7	0613952Q86
C0411M4	21667009166	R0209M7	0613952Q85
C0412M4	2113946F05	R0210M7	0613952Q85
C0413M4	21667009166	R0211M7	21667009380
C0414M4	21667009166	R0212M7	0613952Q32
C0415M4	21667009368	R0213M7	0613952Q67
C0416M4	2113945C31	R0214M7	0613952Q67
C0417M4	21667009166	R0215M7	0613952Q67
C0418M4	21667009164	R0216M7	0613952Q67
C0419M4	21667009274	R0217M7	0613952Q49
C0420M4	21667009166	R0218M7	0613952Q49
C0421M4	21667009274	R0219M7	0613952R66
C0422M4	21667009320	R0220M7	0613952R66
C0423M4	21667009368	R0221M7	0613952R66
C0424M4	21667009274	R0222M7	0613952Q84
C0425M4	21667009320	R0223M7	0613952Q73
C0426M4	2113946F05	R0224M7	0613952Q85
C0427M4	21667009372	R0225M7	0613952Q73
C0428M4	21667009005	R0226M7	0613952Q29

Circuit Ref.	Motorola Solutions Part No.	Circuit Ref.	Motorola Solutions Part No.
C0429M4	21667009274	R0227M7	0613952G67
C0430M4	21667009161	R0228M7	0613952Q67
C0431M4	21667009370	R0230M7	0613952Q67
C0433M4	21667009166	R0232M7	0613952Q49
C0434M4	21667009384	R0233M7	0613952R66
C0435M4	21667009378	R0234M7	NOT PLACED
C0436M4	21667009166	R0235M7	0613952Q18
C0437M4	2113945C31	R0250M7	21667009380
C0438M4	21667009166	R0300M7	0613952Q66
C0439M4	21667009339	R0301M7	0613952Q25
C0440M4	21667009297	R0302M7	0613952Q66
C0441M4	21667009339	R0303M7	0613952R05
C0442M4	21667009286	R0304M7	0613952Q89
C0443M4	21667009346	R0305M7	0613952Q33
C0444M4	21667009274	R0306M7	0613952Q32
C0445M4	21667009392	R0307M7	0613952Q49
C0446M4	21667009346	R0308M7	0613952Q32
C0447M4	21667009282	R0309M7	0613952Q42
C0448M4	21667009339	R0400M4	0613952R01
C0449M4	21667009315	R0401M4	0613952H73
C0450M4	21667009388	R0402M4	0613952R25
C0451M4	21667009166	R0403M4	0613952R01
C0452M4	21667009339	R0404M4	0613952R25
C0453M4	21667009339	R0405M4	0613952R05
C0454M4	21667009346	R0406M4	0613952Q91
C0455M4	21667009346	R0407M4	0613952Q91
C0456M4	21667009366	R0408M4	0613952Q75
C0457M4	21667009291	R0409M4	0613952Q69
C0458M4	2113946F05	R0410M4	0613952R01
C0459M4	21667009355	R0411M4	0613952R01
C0460M4	21667009384	R0412M4	0613952Q83
C0461M4	NOT PLACED	R0413M4	0613958H55
C0462M4	21667009159	R0414M4	0613958H55
C0463M4	NOT PLACED	R0415M4	0613952Q57
C0464M4	21667009158	R0416M4	0613952Q69

Circuit Ref.	Motorola Solutions Part No.	Circuit Ref.	Motorola Solutions Part No.
C0465M4	21667009166	R0417M4	0613952Q69
C0468M4	21667009166	R0418M4	0613952Q69
C0469M4	21667009166	R0419M4	0613952Q69
C0470M4	21667009380	R0420M4	0613952R25
C0471M4	NOT PLACED	R0421M4	0613952R25
C0472M4	NOT PLACED	R0422M4	NOT PLACED
C0473M4	NOT PLACED	R0423M4	0613952R25
C0499M4	NOT PLACED	R0424M4	0613952R66
C0500M3	21667009369	R0425M4	NOT PLACED
C0501M3	21667009332	R0426M4	0613952Q87
C0502M3	2113944M21	R0427M4	0613952Q93
C0503M3	2113945C31	R0429M4	0613952R66
C0504M3	2113945C31	R0430M4	NOT PLACED
C0505M3	21667011351	R0431M4	0613952R01
C0506M3	NOT PLACED	R0432M4	0613952H73
C0507M3	21667009374	R0433M4	0613952R01
C0508M3	21667009366	R0434M4	0613952L46
C0509M3	21667009382	R0435M4	0613952L46
C0510M3	21667009366	R0436M4	0613952R66
C0511M3	21667009355	R0437M4	0613952Q77
C0512M3	21667009303	R0438M4	0613958H22
C0513M3	21667009368	R0439M4	0613952Q83
C0515M3	21667009383	R0440M4	0613958H25
C0516M3	21667011464	R0441M4	0613958H49
C0517M3	21667009315	R0442M4	0613952Q83
C0518M3	21667009339	R0443M4	0613952Q25
C0700M6	2113944C45	R0444M4	0613952K25
C0701M6	2113944A41	R0445M4	0613952Q75
C0702M6	2113944C38	R0446M4	NOT PLACED
C0703M6	21667009163	R0447M4	0613952R66
C0704M6	2113944A41	R0448M4	0613952Q12
C0705M6	2113944A41	R0500M3	0613952Q87
C0706M6	NOT PLACED	R0501M3	0613952R19
C0707M6	2113944C82	R0502M3	0613952Q66
C0708M6	2113944C30	R0503M3	0613952Q88

Circuit Ref.	Motorola Solutions Part No.	Circuit Ref.	Motorola Solutions Part No.
C0709M6	2113945C04	R0504M3	0613952Q61
C0710M6	2113944A41	R0505M3	0613952R66
C0711M6	2113944C47	R0525M3	0613952R66
C0712M6	2113945C04	R0700M6	0613952H90
C0713M6	2113944A41	R0701M6	0613952G67
C0714M6	21012094097	R0702M6	0613952H89
C0715M6	2113944A41	R0703M6	0613952J01
C0716M6	2113944C55	R0704M6	0613952J10
C0717M6	2113944C39	R0705M6	0613952Q46
C0718M6	NOT PLACED	R0706M6	0613952Q58
C0719M6	2113944A41	R0707M6	0613952Q46
C0720M6	2113944A37	R0708M6	0613952H44
C0721M6	2113944C82	R0709M6	NOT PLACED
C0722M6	NOT PLACED	R0711M6	0613958S44
C0723M6	2113945C04	R0712M6	0613958S44
C0724M6	2113944C34	R0713M6	NOT PLACED
C0725M6	NOT PLACED	R0714M6	0613952H09
C0726M6	2113944C51	R0715M6	0613952H09
C0727M6	NOT PLACED	R0716M6	0613952H09
C0728M6	NOT PLACED	R0717M6	0613952H09
C0729M6	NOT PLACED	R0718M6	0613952J05
C0730M6	NOT PLACED	R0719M6	0613952H89
C0731M6	2113944A41	R0720M6	0613952H95
C0732M6	2113945A09	R0721M6	0613952G67
C0733M6	NOT PLACED	R0722M6	0613952H32
C0734M6	2113945A09	R0723M6	0613952G67
C0735M6	21012094093	R0724M6	NOT PLACED
C0736M6	NOT PLACED	R0725M6	0613958S29
C0737M6	2113944C51	R0726M6	NOT PLACED
C0738M6	2113944A41	R0727M6	0613958S29
C0739M6	2113945C31	R0728M6	NOT PLACED
C0740M6	2113944C51	R0729M6	NOT PLACED
C0741M6	2113944C82	R0730M6	NOT PLACED
C0742M6	2113945L49	R0731M6	0613958S29
C0743M6	2113944C35	R0732M6	NOT PLACED

Circuit Ref.	Motorola Solutions Part No.	Circuit Ref.	Motorola Solutions Part No.
C0744M6	2113944C34	R0733M6	NOT PLACED
C0745M6	2113946J04	R0734M6	0613958S29
C0746M6	NOT PLACED	R0736M6	0613959Q25
C0747M6	2113944C45	R0737M6	0613952F01
C0748M6	NOT PLACED	R0738M6	0613959Q53
C0749M6	2113944C83	R0739M6	0613952H73
C0750M6	NOT PLACED	R0740M6	NOT PLACED
C0751M6	NOT PLACED	R0741M6	0613952E66
C0752M6	2113944C85	R0742M6	NOT PLACED
C0753M6	2113944C51	R0743M6	0613952E66
C0754M6	2113944C45	R0744M6	0613959Q53
C0755M6	2113944C85	R0745M6	NOT PLACED
C0756M6	NOT PLACED	R0746M6	0613952F01
C0757M6	NOT PLACED	R0759M6	0613959H12
C0758M6	21667003042	R0849M6	0613952G67
C0759M6	21667003042	R0876M6	0613958S73
C0760M6	2113944C45	R0877M6	0613959Y37
C0761M6	2113944C45	R0878M6	0613959Y37
C0762M6	21012094096	R0879M6	0613952J25
C0763M6	21012094096	R0883M6	0613952G67
C0764M6	2113944C51	R0902M6	0613952R66
C0765M6	21667003033	R0903M6	0613952N01
C0766M6	21667003033	R0904M6	0613952R66
C0767M6	NOT PLACED	R0905M6	0613952H42
C0768M6	NOT PLACED	R0906M6	0613958H46
C0769M6	NOT PLACED	R0907M6	0613958H55
C0770M6	21667003029	R0908M6	0613952H42
C0771M6	NOT PLACED	R0909M6	NOT PLACED
C0772M6	2113944C35	R0910M6	0613952H91
C0773M6	NOT PLACED	R0911M6	0613952H85
C0774M6	NOT PLACED	R0912M6	0613958H46
C0775M6	NOT PLACED	R0913M6	0613952M51
C0776M6	21667003038	R0914M6	0613952M71
C0777M6	21012094097	R0915M6	NOT PLACED
C0778M6	21012094097	R0916M6	0613952R66

Circuit Ref.	Motorola Solutions Part No.	Circuit Ref.	Motorola Solutions Part No.
C0779M6	NOT PLACED	R0917M6	0613952P01
C0780M6	21012094093	R0919M6	0613952P01
C0781M6	NOT PLACED	R0920M6	0613952N01
C0782M6	NOT PLACED	R0921M6	0613952N01
C0783M6	21667003038	R0922M6	0613952R66
C0784M6	NOT PLACED	R0923M6	0613952M30
C0785M6	21012094093	R0924M6	0613952N01
C0786M6	NOT PLACED	R0925M6	0613952Q59
C0787M6	21012094048	R0926M6	0613952H79
C0788M6	21012094048	R0927M6	0613952N01
C0789M6	2113944C36	R0928M6	0613952P18
C0790M6	2113944C82	R0929M6	0613952N85
C0791M6	21667011042	R0930M6	0613952N37
C0792M6	21012094089	R0931M6	0613952M77
C0793M6	2113944C32	R0932M6	0613952N43
C0794M6	2113944C82	R0933M6	0613952M37
C0795M6	21667011042	R0934M6	0613952J17
C0796M6	2113944C39	R0935M6	0613952H91
C0797M6	2113944C39	R0936M6	0613952H91
C0798M6	2113944C38	R0937M6	NOT PLACED
C0799M6	2113944C38	R0938M6	NOT PLACED
C0800M6	2113944C32	R0939M6	0613952R66
C0801M6	2113944C38	R0940M6	0613952Z76
C0802M6	2113944C38	R0941M6	0613952N58
C0803M6	2113944C38	R0942M6	0613952N58
C0804M6	2113944C38	R0943M6	0613952N58
C0805M6	2113944C32	R0950M6	0613952G67
C0806M6	21012094089	R0951M6	0613958M21
C0807M6	21012094092	R0952M6	0613958M21
C0808M6	21012094097	R0953M6	0613952G67
C0809M6	21012094092	R0954M6	0613952H58
C0810M6	21012094048	R0955M6	0613952H58
C0811M6	21012094048	R0956M6	0613952H67
C0812M6	2113944C38	R0957M6	0613958C18
C0813M6	2113944C38	R0958M6	0613958C18

Circuit Ref.	Motorola Solutions Part No.	Circuit Ref.	Motorola Solutions Part No.
C0814M6	2113944C38	R0959M6	0613952R66
C0815M6	2113944C38	R0960M6	0613952N58
C0816M6	21012094097	R0961M6	0613952N58
C0817M6	21667003033	R0962M6	0613952N58
C0818M6	NOT PLACED	R0965M6	NOT PLACED
C0819M6	21667003033	R0966M6	NOT PLACED
C0820M6	21012094092	R0980M6	0613952N43
C0821M6	NOT PLACED	R0981M6	0613952P01
C0822M6	NOT PLACED	R1000M1	0613952R66
C0823M6	NOT PLACED	R1001M1	0613952M66
C0824M6	21012094089	R1002M1	0613952R66
C0825M6	21012094097	R1003M1	0613952R66
C0826M6	21667011491	R1004M1	0613952R66
C0827M6	21667011491	R1005M1	0613952M66
C0828M6	2113944C35	R1007M1	0613952R66
C0829M6	2113944C82	R1008M1	0613952R66
C0830M6	2113944C84	R1009M1	0613952R66
C0831M6	2113944C34	R1010M1	NOT PLACED
C0832M6	2113944C32	R1011M1	NOT PLACED
C0833M6	2113944C82	R1012M1	0613952R66
C0834M6	2113944C33	R1013M1	0613952M66
C0835M6	21012094048	R1014M1	NOT PLACED
C0836M6	2113944C90	R1016M1	NOT PLACED
C0837M6	NOT PLACED	R1018M1	NOT PLACED
C0838M6	21012094085	R1019M1	0613952R66
C0839M6	21667011146	R1020M1	0613952M66
C0840M6	21012094085	R1021M1	0613952Q73
C0841M6	2113944C37	R1022M1	NOT PLACED
C0842M6	NOT PLACED	R1023M1	0613952R66
C0843M6	2113944C37	R1024M1	NOT PLACED
C0844M6	NOT PLACED	R1025M1	0613952Q73
C0845M6	21667009291	R1026M1	0613952R66
C0846M6	21667009320	R1027M1	NOT PLACED
C0847M6	21667009320	R1028M1	0613952R66
C0848M6	2113944C45	R1029M1	0613952R66

Circuit Ref.	Motorola Solutions Part No.	Circuit Ref.	Motorola Solutions Part No.
C0849M6	2113944C08	R1030M1	NOT PLACED
C0850M6	21012094085	R1031M1	0613952R66
C0851M6	21012094089	R1033M1	0613952Q73
C0852M6	21012094086	R1034M1	0613952R17
C0853M6	21012094092	R1035M1	NOT PLACED
C0854M6	21012094090	R1036M1	0613952M66
C0855M6	21012094090	R1037M1	0613952M66
C0856M6	21012094048	R1038M1	0613952R66
C0857M6	21012094089	R1039M1	0613952R66
C0858M6	NOT PLACED	R1040M1	0613952M66
C0859M6	21012094086	R1041M1	0613952R66
C0860M6	21012094086	R1042M1	0613952M66
C0861M6	21012094092	R1043M1	0613952R66
C0862M6	21012094092	R1044M1	0613952M66
C0863M6	21012094092	R1045M1	0613952M66
C0864M6	21012094092	R1046M1	0613952M66
C0865M6	NOT PLACED	R1047M1	0613952R66
C0866M6	21012094090	R1048M1	0613952R66
C0867M6	21012094090	R1049M1	0613952Q73
C0868M6	21012094082	R1050M1	0613952Q73
C0869M6	21012094090	R1051M1	0613952K68
C0870M6	21012094048	R1052M1	NOT PLACED
C0871M6	2113944C85	R1053M1	0613952R66
C0872M6	2113944C85	R1054M1	0613952M66
C0873M6	21667003028	R1056M1	0613952Q73
C0874M6	NOT PLACED	R1057M1	0613952Q73
C0875M6	2113944C46	R1058M1	0613952M66
C0876M6	NOT PLACED	R1059M1	0613952R66
C0877M6	2113944C42	R1060M1	0613952R66
C0878M6	NOT PLACED	R1061M1	0613952R66
C0879M6	2113944C42	R1062M1	NOT PLACED
C0880M6	21667003028	R1063M1	NOT PLACED
C0881M6	21012094048	R1064M1	NOT PLACED
C0882M6	21667011146	R1065M1	0613952R66
C0883M6	21667011491	R1066M1	0613952M66

Circuit Ref.	Motorola Solutions Part No.	Circuit Ref.	Motorola Solutions Part No.
C0884M6	2113944C90	R1067M1	0613952M66
C0885M6	2113944C51	R1068M1	0613952R32
C0886M6	2113944C47	R1069M1	NOT PLACED
C0887M6	21012094082	R1070M1	0613952Q77
C0888M6	21012094102	R1071M1	0613952Q77
C0889M6	NOT PLACED	R1072M1	0613952Q49
C0890M6	NOT PLACED	R1073M1	0613952R01
C0891M6	21667003028	R1074M1	0613952R66
C0892M6	NOT PLACED	R1075M1	0613952R66
C0900M6	NOT PLACED	R1076M1	0613952R66
C0901M6	NOT PLACED	R1077M1	0613952R66
C0902M6	2113944C51	R1078M1	0613952R66
C0905M6	2113945C31	R1079M1	0613952R66
C0906M6	2113945A10	R1080M1	0613952Q32
C0907M6	2113945L41	R1081M1	0613952Q32
C0908M6	21667009166	R1082M1	0613952Q32
C0909M6	2113944C02	R1084M1	0613952R66
C0910M6	21667009166	R1088M1	NOT PLACED
C0911M6	2113944C02	R1089M1	0613952R05
C0912M6	21667009166	R1090M1	0613952R05
C0913M6	21667009166	R1091M1	NOT PLACED
C0916M6	NOT PLACED	R1092M1	0613952M43
C0917M6	21667009166	R1093M1	0613952Q73
C0918M6	21667009166	R1094M1	0613952M66
C0919M6	21667009166	R1095M1	0613952Q34
C0920M6	2113944C02	R1096M1	0613952Q34
C0921M6	2113944C02	R1097M1	0613952R66
C0922M6	2113945C31	R1098M1	0613952R66
C0923M6	2113944C02	R2000M1	0613952M66
C0924M6	21667009166	R2002M1	0613952M66
C0925M6	2113945C31	R2003M1	0613952M30
C0926M6	2113944C02	R3000M6	0613952H60
C0927M6	2113944C01	R3001M6	0615871H01
C0928M6	2113944C51	R3002M6	0615871H01
C0929M6	2113944C49	R3003M6	0615871H01

Circuit Ref.	Motorola Solutions Part No.	Circuit Ref.	Motorola Solutions Part No.
C0930M6	NOT PLACED	R3004M6	0615871H01
C0931M6	2113944C02	R3005M6	0613952H25
C0950M6	2113944C47	R3006M6	0613952H25
C0951M6	21667011356	R3007M6	0613952M30
C0952M6	2113944C47	R3008M6	0613952G67
C0953M6	2113944C47	R3009M6	0613952M43
C0954M6	21667011351	R3010M6	0613952G67
C0955M6	2113944C47	R3011M6	0613959Q60
C0956M6	2113944C01	R3012M6	0613959Q60
C0957M6	2113944C49	R3013M6	0613952R01
C1000M1	2113945Y02	R3014M6	0613952R01
C1001M1	2113945Y02	R3015M6	0615871H01
C1002M1	2113946K03	R3018M6	0613952H73
C1003M1	2113945Y02	R3019M6	0613952H60
C1004M1	2113945Y02	R3020M6	0613952G67
C1005M1	2113945Y02	R3021M6	0613952R25
C1006M1	2113945Y02	R3022M6	0613952R66
C1007M1	2113945Y02	R3023M6	NOT PLACED
C1008M1	2113946D05	R3101M1	0613952Z66
C1009M1	2113945Y02	R3102M1	0613952M66
C1010M1	2113945Y02	R3103M1	0613952N62
C1011M1	2113945B02	R3104M1	0613952M30
C1012M1	2113945Y02	R3105M1	0613952R01
C1013M1	2113945Y02	R3106M1	0613952M09
C1014M1	2113945Y02	R3107M1	0613952M85
C1015M1	2113945B02	R3108M1	0613952R17
C1016M1	21667009166	R3109M1	0613952R17
C1017M1	21667009162	R3110M1	0613952N55
C1018M1	21667009162	R3111M1	0613952R32
C1019M1	21667009162	R3112M1	0613952P12
C1020M1	21667009162	R3113M1	0613952R17
C1021M1	2113945Y02	R3114M1	0613952N01
C1022M1	2113945Y02	R3115M1	0613952Z63
C1023M1	2113945Y02	R3116M1	0613952E83
C1024M1	2113945Y02	R3117M1	0613952Q73

Circuit Ref.	Motorola Solutions Part No.	Circuit Ref.	Motorola Solutions Part No.
C1025M1	2113945Y02	R3118M1	0613952R10
C1026M1	2113945Y02	R3119M1	0613952Q73
C1027M1	NOT PLACED	R3120M1	0613952R66
C1028M1	2113945Y02	R3121M1	0613952R66
C1029M1	2113956B54	R3122M1	0613952M43
C1032M1	2113956B54	R3123M1	0613952M54
C1035M1	2113945B02	R3124M1	0613952R66
C1036M1	2113946D05	R3125M1	0613952R66
C1040M1	2113945Y02	R3126M1	0613952R66
C1041M1	2113945B02	R3127M1	0613959Y09
C1042M1	2113945Y02	R3128M1	0613952M10
C1043M1	2113956B54	R3129M1	0613952M58
C1044M1	2113945B02	R3130M1	0613952R25
C1045M1	2113945B02	R3131M1	0613952R01
C1047M1	2113945Y02	R3132M1	0613952R01
C1048M1	2113945B02	R3133M1	0613952R29
C2000M1	2113945Y02	R3134M1	NOT PLACED
C2001M1	2113945Y02	R3135M1	0613952R66
C2002M1	2113945B02	R3136M1	0613952R17
C2003M1	21667009162	R3137M1	0613952R17
C2004M1	2113956B54	R3138M1	0613952R17
C2005M1	2113946D05	R3139M1	0613952R66
C2006M1	2113945Y02	R3140M1	0613952Q91
C2007M1	2113945Y02	R3141M1	0613959Y13
C2008M1	2113945B02	R3142M1	NOT PLACED
C2009M1	21667009162	R3143M1	0613952Q91
C2010M1	2113945Y02	R3144M1	0613952R66
C2011M1	2113945Y02	R3145M1	0613959Y09
C2012M1	2113945Y02	R3146M1	0613952M85
C2013M1	2113945Y02	R3147M1	0613952M43
C2014M1	2113945B02	R3148M1	0613952R66
C2015M1	21667009162	R3149M1	0613952R01
C2016M1	2113956B54	R3150M1	0613952N62
C2020M1	2113956B54	R3151M1	0613952R25
C2021M1	2113956D59	R3153M1	0613952R66

Circuit Ref.	Motorola Solutions Part No.	Circuit Ref.	Motorola Solutions Part No.
C2022M1	2113956D59	R3154M1	0613952Q89
C3000M6	2113944C38	R3155M1	0613952Q89
C3001M6	2113944C06	R3156M1	0613952R17
C3002M6	2113944C06	R3157M1	0613952R01
C3003M6	2113945C31	R3158M1	0613952R66
C3004M6	2113945C02	R3159M1	0613952R01
C3005M6	2113945C02	R3160M1	0613952Q89
C3008M6	2113944C51	R3161M1	0613952Q73
C3009M6	2113945C31	R3162M1	0613952Q85
C3010M6	2113944C46	R3163M1	0613952R01
C3011M6	NOT PLACED	R3164M1	0613952Q75
C3012M6	2113946J04	R3165M1	0613952R01
C3013M6	2113945C31	R3166M1	0613952R17
C3014M6	21009337414	R3167M1	0613952R01
C3015M6	2113946G01	R3168M1	0613952Q73
C3016M6	2113945C31	R3169M1	0613952R01
C3019M6	2113946S35	R3170M1	0613952R01
C3020M6	2113945C26	R3171M1	NOT PLACED
C3021M6	2113944C06	R3172M1	NOT PLACED
C3022M6	2113945A10	R3173M1	0613952R66
C3029M6	NOT PLACED	R3174M1	0613952R66
C3038M6	21667009379	R3175M1	0689774Y02
C3041M6	21667009379	R3176M1	0689774Y02
C3042M6	21667009379	R3177M1	0613952R66
C3044M6	21667009379	R3178M1	0615871H01
C3046M6	NOT PLACED	R3179M1	0613952R17
C3047M6	NOT PLACED	R3180M1	0613952R01
C3048M6	NOT PLACED	R3181M1	NOT PLACED
C3049M6	NOT PLACED	R3182M1	0613952R66
C3102M1	21009337414	R3183M1	0613952H92
C3103M1	21667009166	R3184M1	0613952M30
C3104M1	2113946F08	R3200M1	0613952C44
C3105M1	2113946J04	R3201M1	0613952Q49
C3106M1	2113945C31	R3202M1	0613952C44
C3107M1	2113944C38	R3203M1	0613952Q49

Circuit Ref.	Motorola Solutions Part No.	Circuit Ref.	Motorola Solutions Part No.
C3109M1	21667009166	R3204M1	0613952C44
C3110M1	2113944C06	R3205M1	0613952C44
C3111M1	2113946J04	R3206M1	0613952R01
C3112M1	2113945Y02	R3207M1	0613952R01
C3113M1	2113946S35	R3208M1	0613952N30
C3115M1	2113944C06	R3209M1	0613952R03
C3116M1	2113955D13	R3210M1	0613952Q67
C3117M1	2113955D13	R3211M1	0613952N30
C3118M1	2113945Y02	R3212M1	0613952R03
C3119M1	2113945Y02	R3213M1	0613952Q42
C3120M1	2113956E60	R3214M1	0613952J25
C3121M1	2113956D58	R3215M1	0613952R01
C3122M1	2113956A51	R3216M1	0613952R17
C3123M1	2113956A51	R3217M1	0613952R01
C3124M1	2113946D07	R3218M1	0613952R01
C3125M1	2113946D05	R3219M1	NOT PLACED
C3126M1	2113944C06	R3220M1	0613952R01
C3127M1	2113946S35	R3221M1	NOT PLACED
C3128M1	2113946D05	R3222M1	0613952R01
C3129M1	2113945Y02	R3223M1	0613952R66
C3130M1	2113946D05	R3224M1	NOT PLACED
C3131M1	2113946A02	R3225M1	NOT PLACED
C3132M1	2113946D05	R3226M1	0613952R01
C3133M1	2113946D05	R3229M1	0613952R01
C3134M1	2113946S35	R3230M1	0613952R10
C3135M1	2113956A51	R3231M1	0613952R10
C3136M1	21012095001	R3232M1	0613952R10
C3137M1	2113946D05	R3233M1	0613952R01
C3139M1	2113956A51	R3234M1	NOT PLACED
C3140M1	21012095001	R3235M1	0613952R01
C3141M1	2113945Y02	R3236M1	0613952R10
C3142M1	21012102001	R3237M1	NOT PLACED
C3143M1	21667009366	R3238M1	0613952R01
C3144M1	2113945Y02	R3239M1	0613952Q49
C3145M1	2113944C06	R3240M1	0613952R01

Circuit Ref.	Motorola Solutions Part No.	Circuit Ref.	Motorola Solutions Part No.
C3146M1	21012102001	R3241M1	0613952M54
C3149M1	2113956A51	R3242M1	0613952R01
C3150M1	2113956C37	R3243M1	0613952R01
C3151M1	2113945B02	R3244M1	0613952R10
C3152M1	2113944C06	R3245M1	NOT PLACED
C3153M1	2113946J04	R3246M1	0613952R01
C3154M1	2113955D13	R3247M1	0613952Q49
C3155M1	2113945Y02	R3248M1	0613952R66
C3156M1	2113945Y02	R3249M1	0613952R66
C3157M1	2113945Y02	R3250M1	0613952R66
C3160M1	2113945Y02	R3251M1	0613952R66
C3161M1	NOT PLACED	R3252M1	0613952R66
C3171M1	2113946D07	R3253M1	0613952R66
C3173M1	2113946D07	R3254M1	0613952R01
C3175M1	2113946A01	R3255M1	0613952R66
C3176M1	2113944C48	R3256M1	0613952M66
C3177M1	2113946F08	R3257M1	0613952R01
C3200M1	21667009166	R3258M1	0613952M66
C3201M1	21667009166	R3259M1	0613952M66
C3203M1	2113955D37	R3260M1	0613952M66
C3204M1	2113955D37	R3261M1	0613952R01
C3205M1	21667009166	R3262M1	0613952R10
C3206M1	21667009166	R3263M1	NOT PLACED
C3208M1	2113956C37	R3264M1	0613952R01
C3209M1	2113945Y02	R3265M1	0613952M66
C3210M1	2113945Y02	R3266M1	0613952R01
C3211M1	2113945A11	R3267M1	NOT PLACED
C3212M1	2113955D37	R3268M1	0613952R01
C3213M1	2113945A03	R3269M1	0613952M66
C3214M1	2113955D37	R3270M1	0613952R01
C3215M1	2113956F49	R3271M1	NOT PLACED
C3216M1	2113945Y02	R3272M1	0613952R01
C3217M1	2113956B91	R3273M1	0613952M66
C3218M1	2113956A51	R3274M1	0613952R10
C3219M1	2113956A51	R3275M1	0613952R10

Circuit Ref.	Motorola Solutions Part No.	Circuit Ref.	Motorola Solutions Part No.
C3220M1	2113946F05	R3276M1	0613952R10
C3221M1	2113945Y02	R3277M1	0613952R10
C3222M1	2113956A51	R3278M1	0613952R01
C3223M1	2113945Y02	R3279M1	NOT PLACED
C3224M1	2113946F05	R3280M1	NOT PLACED
C3225M1	2113945Y02	R3281M1	NOT PLACED
C3226M1	NOT PLACED	R3282M1	0613952R66
C3227M1	2113946F05	R3283M1	0613952R66
C3228M1	2113945Y02	R3285M1	0613952R01
C3229M1	2113956A51	R3286M1	0613952R66
C3230M1	2113945Y02	R3287M1	0613952R66
C3231M1	2113945Y02	R3288M1	0613952R01
C3232M1	2113945Y02	R3289M1	0613952R01
C3233M1	2113945A09	R3290M1	NOT PLACED
C3234M1	2113945Y02	R3291M1	NOT PLACED
C3235M1	21012102001	R3292M1	0613952R66
C3236M1	2113945C31	R3293M1	0613952R66
C3237M1	21009337414	R4001M1	0613952R66
C3238M1	2113945A09	R4003M1	0613952R66
C3239M1	2113945A09	R4006M1	0613952Q37
C3240M1	2113956B91	R4007M1	0613952Q37
C3241M1	2113956B91	R4008M1	0613952R01
C3242M1	2113945C31	R4010M1	0613952R01
C3243M1	2113955D37	R4013M1	0613952Q42
C3244M1	2113956B91	R4015M1	0613952Q37
C3245M1	2113955D37	R4021M1	0613952R66
C3246M1	2113945C31	R4024M1	0613952R01
C3247M1	2113945Y02	R4025M1	0613952R01
C3248M1	2113945Y02	R4026M1	0613952R66
C3249M1	2113956B91	R4027M1	0613952R66
C3250M1	2113956B91	R4028M1	0613952R01
C4000M1	2113945Y02	R4029M1	0613952R01
C4001M1	2113945Y02	R4030M1	0613952R01
C4002M1	2113945Y02	R4031M1	0613952R01
C4003M1	2113945Y02	R4032M1	0613952R66

Circuit Ref.	Motorola Solutions Part No.	Circuit Ref.	Motorola Solutions Part No.
C4010M1	21667009166	R4033M1	0613952M43
C4011M1	21667009166	R4034M1	0613952M43
C4012M1	21667009166	R4035M1	0613952R66
C4013M1	21667009166	R4036M1	0613952R66
C4014M1	21667009166	R4037M1	0613952R01
C4015M1	21667009166	R4038M1	0613952R01
C4019M1	21667009166	R4039M1	NOT PLACED
C4020M1	21667009166	R4040M1	NOT PLACED
C4021M1	21667009166	R4041M1	NOT PLACED
C4022M1	21667009166	R4100M1	0613952R01
C4023M1	21667009166	R4101M1	0613952Q77
C4025M1	21667009166	R4102M1	0613958H83
C4026M1	21667009166	R4103M1	0613952Q85
C4027M1	21667009166	R4104M1	0613952Q89
C4028M1	21667009166	R4105M1	0613952Q89
C4029M1	21667009166	R4106M1	0613952Q89
C4030M1	21667009166	R4107M1	0613952R01
C4100M1	21667009166	R4108M1	0613952Q89
C4101M1	21667009166	R4109M1	0613952N58
C4103M1	21667009166	R4110M1	0613952Q85
C4104M1	21667009166	R4111M1	0613952Q85
C4105M1	21667009166	R4112M1	0613952R01
C4106M1	21667009166	R4113M1	0613952R01
C4107M1	21667009166	R4114M1	0613952Q89
C4108M1	21667009166	R4115M1	0613952N58
C4109M1	21667009166	R4116M1	0613952Q89
C4110M1	21667009166	R4117M1	0613952R01
C4112M1	21667009166	R4118M1	0613952R01
C4113M1	21667009166	R4119M1	0613952R01
C4114M1	21667009166	R4120M1	0613952N58
C4115M1	21667009166	R4121M1	0613952Q85
C4116M1	21667009166	R4122M1	0613952Q85
C4117M1	21667009166	R4123M1	0613952N58
C4118M1	21667009166	R4124M1	0613952N58
C4119M1	21667009166	R4125M1	0613952Q85

Circuit Ref.	Motorola Solutions Part No.	Circuit Ref.	Motorola Solutions Part No.
C4200M1	2113945Y02	R4126M1	0613952Q85
C4201M1	2113945Y02	R4127M1	0613952Q85
C4202M1	21667009166	R4128M1	0613952R01
C4203M1	21667009166	R4200M1	0613952R66
C4204M1	NOT PLACED	R4201M1	0613952R66
C4205M1	21667009166	R4202M1	0613952R66
C4206M1	21667009166	R4203M1	0613952R66
C4207M1	21667009166	R4204M1	0613952R66
C4208M1	21667009166	R4205M1	0613952R66
C4209M1	21667009166	R4206M1	0613952R66
C4210M1	21667009166	R4207M1	0613952R66
C4211M1	21667009166	R4208M1	0613952R66
C4212M1	21667009166	R4209M1	HZ000375A01
C4213M1	21667009166	R4210M1	HZ000375A01
C4214M1	21667009166	R4211M1	HZ000375A01
C4218M1	21667009166	R4212M1	HZ000375A01
C4219M1	21667009339	R4213M1	HZ000375A01
C4220M1	21667009339	R4214M1	HZ000375A01
C4221M1	21667009339	R4215M1	0613952R66
C4222M1	21667009339	R4216M1	0613952R66
C4223M1	21667009339	R4217M1	0613952R66
C4224M1	21667009166	R4218M1	0613952R66
C4225M1	21667009166	R4301M1	NOT PLACED
C4226M1	21667009339	R4302M1	0613952R66
C4300M1	NOT PLACED	R4303M1	0613952R66
C4301M1	NOT PLACED	R4304M1	0613952R66
C4302M1	NOT PLACED	R4305M1	0613952R66
C4303M1	NOT PLACED	R4306M1	0613952R66
C4304M1	21667009166	R4307M1	0613952R66
C4305M1	21667009376	R4309M1	NOT PLACED
C4306M1	21667009381	R4310M1	0613952R66
C4307M1	NOT PLACED	R4311M1	0613952R66
C4308M1	NOT PLACED	R4312M1	0613952R66
C4309M1	21667009166	R4313M1	NOT PLACED
C4310M1	21667009166	R4314M1	0613952R66

Circuit Ref.	Motorola Solutions Part No.	Circuit Ref.	Motorola Solutions Part No.
C4311M1	2113945Y02	R4315M1	0613952R66
C4312M1	2113945Y02	R4316M1	0613952R66
C4313M1	21667009166	R4317M1	0613952R66
C4314M1	NOT PLACED	RT0900M6	0615585H01
C4401M1	NOT PLACED	SH0000M2	26012095001
C4402M1	NOT PLACED	SH0001M2	26012095001
C4403M1	NOT PLACED	SH0002M2	26012097001
C4404M1	NOT PLACED	SH0003M2	26012094001
C4405M1	NOT PLACED	SH0004M2	26012094001
C4406M1	NOT PLACED	SH0200M7	26012095001
C4407M1	NOT PLACED	SH0300M7	26012095001
C4408M1	NOT PLACED	SH0400M4	26012096001
C4409M1	NOT PLACED	SH0401M4	26012096001
C4410M1	NOT PLACED	SH0402M4	26012098001
C4411M1	NOT PLACED	SH0403M4	26012098001
C4412M1	21667009166	SH0500M3	26012098001
C4413M1	21667009166	SH0501M3	NOT PLACED
C4414M1	21667009166	SH0850M6	26012100001
C4415M1	21667009166	SH0900M6	2686425Z02
C4417M1	21667009166	SH0901M6	2686425Z02
C4418M1	21667009166	SH3100M1	NOT PLACED
C4419M1	21667009166	SP3000M6	NOT PLACED
D0000M2	4815011H01	SP3001M6	NOT PLACED
D0001M2	4815011H01	T0000M2	24012146001
D0400M4	4884800Y03	T0400M4	2515121H01
D0401M4	4813974A19	T0401M4	2515121H01
D0402M4	4813974A19	U0000M2	51009877001
D0403M4	4884800Y03	U0001M2	5109731C48
D0404M4	4815090H01	U0002M2	4802197J95
D0500M3	4813974A19	U0200M7	5186310Y39
D0700M6	4813974A06	U0500M3	4802197J95
D0875M6	48012160001	U0901M6	5180390L83
D0876M6	4886622Y06	U0902M6	51012221001
D0877M6	48012160001	U0903M6	5115022H01
D0900M6	48012181001	U0904M6	5109731C48

Circuit Ref.	Motorola Solutions Part No.	Circuit Ref.	Motorola Solutions Part No.
D0950M6	4813974A21	U0905M6	5109731C48
D0951M6	4813974A21	U1000M1	5171320H01
D3000M6	4813978P07	U1001M1	51012295001
D3104M1	4885489Y01	U1002M1	5189139P01
D3160M1	4813978C02	U1003M1	5175772B56
D3161M1	4813978C02	U1004M1	5175772B56
E0000M2	24012095001	U1005M1	5164852H47
E0001M2	24012095001	U1006M1	5185493Y01
E0002M2	NOT PLACED	U1007M1	5189139P01
E0003M2	24012095001	U1008M1	5189139P01
E0004M2	24012095001	U1009M1	5115001H02
E0005M2	24012095001	U1010M1	5171320H01
E0006M2	24012095001	U2000M1	MM000157A01
E0007M2	24012095001	U2001M1	MM000129A01
E0008M2	24012095001	U3000M6	5116525H01
E0009M2	24012095001	U3001M6	4813973M07
E0010M2	24012095001	U3002M6	51012133001
E0200M7	24012095001	U3100M1	0104039J08
E0300M7	24012095001	U3101M1	5114014A01
E0401M4	24012107027	U3102M1	51012069001
E0402M4	24012107027	U3103M1	51012142001
E0403M4	24012107027	U3104M1	5171590Y73
E0404M4	24012107027	U3105M1	5114610F01
E0500M3	24012095001	U3106M1	51012140001
E0700M6	24012102001	U3107M1	51012140001
E0701M6	24012102001	U3108M1	51012138001
E0703M6	24012102001	U3109M1	5164015H94
E1000M1	7686949J15	U3110M1	51012208001
E1001M1	7686949J15	U3111M1	5188690V02
E1002M1	7686949J15	U3112M1	5114004A35
E1003M1	7686949J15	U3113M1	5188690V02
E1004M1	7686949J15	U3114M1	NOT PLACED
E1005M1	7686949J15	U3115M1	5185937Y01
E1006M1	7685268E01	U3200M1	51009415001
E3000M6	24012102001	U3201M1	5114016A18

Circuit Ref.	Motorola Solutions Part No.	Circuit Ref.	Motorola Solutions Part No.
E3100M1	24012102001	U3204M1	51009509001
E3101M1	2485410Y02	U3205M1	5114016A18
E3102M1	2485410Y02	U4000M1	51012082001
E3103M1	2485410Y02	U4001M1	51012082001
E3104M1	7686949J22	U4100M1	5189139P01
E3105M1	7686949J22	U4200M1	NOT PLACED
E3106M1	7686949J22	U4201M1	NOT PLACED
E3107M1	7686949J22	U4300M1	51012082001
E3108M1	7686949J22	U4301M1	51012082001
E3109M1	7686949J22	VR0001M2	4815096H01
E3110M1	7686949J22	VR0200M7	4805656W87
E3111M1	7686949J22	VR0201M7	4805656W87
E3113M1	7686949J22	VR0202M7	4805656W87
E3200M1	24012102001	VR0203M7	4805656W87
E3201M1	24012102001	VR0204M7	4805656W87
E3202M1	24012107027	VR0205M7	4805656W87
E3203M1	24012102001	VR0206M7	4805656W87
E3204M1	24012102001	VR0207M7	4805656W87
E4000M1	24012107027	VR0208M7	4805656W87
E4001M1	7688697V05	VR0209M7	NOT PLACED
E4002M1	24012107027	VR0210M7	4805656W87
E4003M1	NOT PLACED	VR0211M7	4805656W87
E4004M1	24012102001	VR0214M7	4805656W87
E4005M1	2485410Y02	VR0215M7	4805656W87
E4100M1	7686949J14	VR0400M4	4805656W87
E4101M1	24012107027	VR0401M4	4805656W87
E4102M1	NOT PLACED	VR0402M4	4805656W87
E4103M1	NOT PLACED	VR0403M4	4805656W87
E4104M1	NOT PLACED	VR0404M4	4805656W87
E4200M1	24012107027	VR0405M4	4805656W87
E4201M1	24012107027	VR0406M4	4805656W87
E4202M1	24012107027	VR0407M4	4805656W87
E4300M1	24012107027	VR3000M6	48012202001
E4405M1	24012107027	VR3002M6	4813977M10
E4406M1	7686949J22	VR3103M1	48012095001

Circuit Ref.	Motorola Solutions Part No.	Circuit Ref.	Motorola Solutions Part No.
E4407M1	7686949J22	VR3104M1	48012095002
E4408M1	24012107027	VR3105M1	4813977M10
E4409M1	24012102001	VR3200M1	48012049001
F4000M1	65012019001	VR3201M1	4813977A48
FL0500M3	9116854H02	VR3202M1	4813977A48
FL4000M1	24012038001	VR4000M1	4813977M13
FL4001M1	24012038001	VR4001M1	4813977A48
J0700M6	09009348002	VR4002M1	48012153001
J4000M1	0915767H01	VR4100M1	4813977A48
J4001M1	0915556H01	VR4101M1	4813977A48
J4100M1	0916017H01	VR4102M1	4813977A48
J4200M1	09012053001	VR4103M1	4813977A48
J4400M1	09012053001	VR4104M1	48012049001
L0000M2	24012154001	VR4105M1	4813977M13
L0001M2	24667001020	VR4106M1	4813977A48
L0002M2	2414017K32	VR4107M1	4813977A48
L0003M2	24667001031	VR4108M1	4813977A48
L0004M2	24009343017	VR4109M1	4813977A50
L0005M2	24667001017	VR4110M1	4815040H01
L0200M7	24667001031	VR4111M1	48012153001
L0201M7	24667001031	Y0000M2	4875185M05
L0202M7	2415385H01	-	-



NOTICE: The suffix "M1", "M2", and so on from the Circuit Ref. is removed from the schematic and overlays.

8.7.1.3

Circuit Board and Schematic Diagrams for 84012728003-C

Figure 238: Main Board Top Side PCB No. 84012728003-C

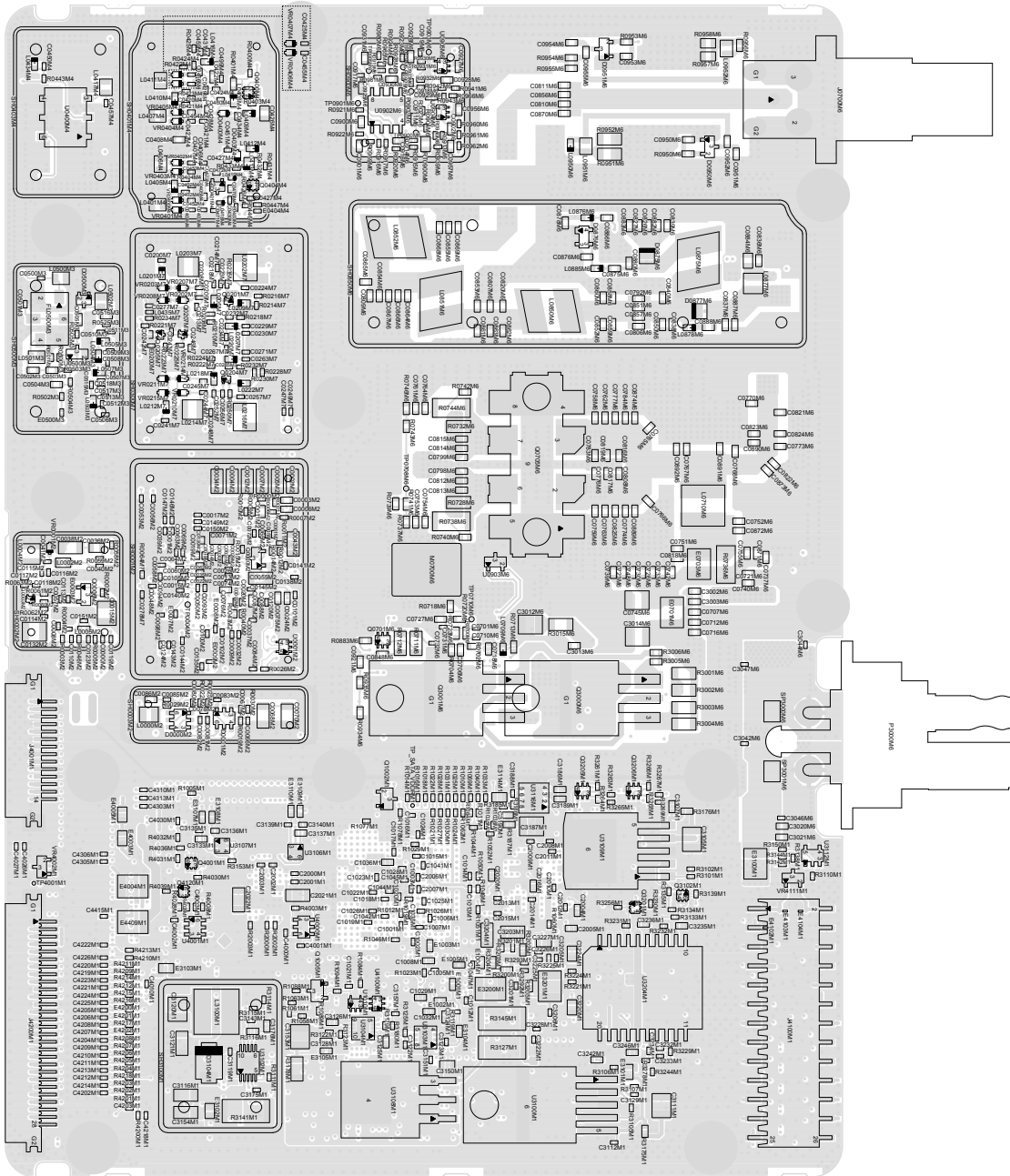

Figure 239: Main Board Bottom Side PCB No. 84012728003-C

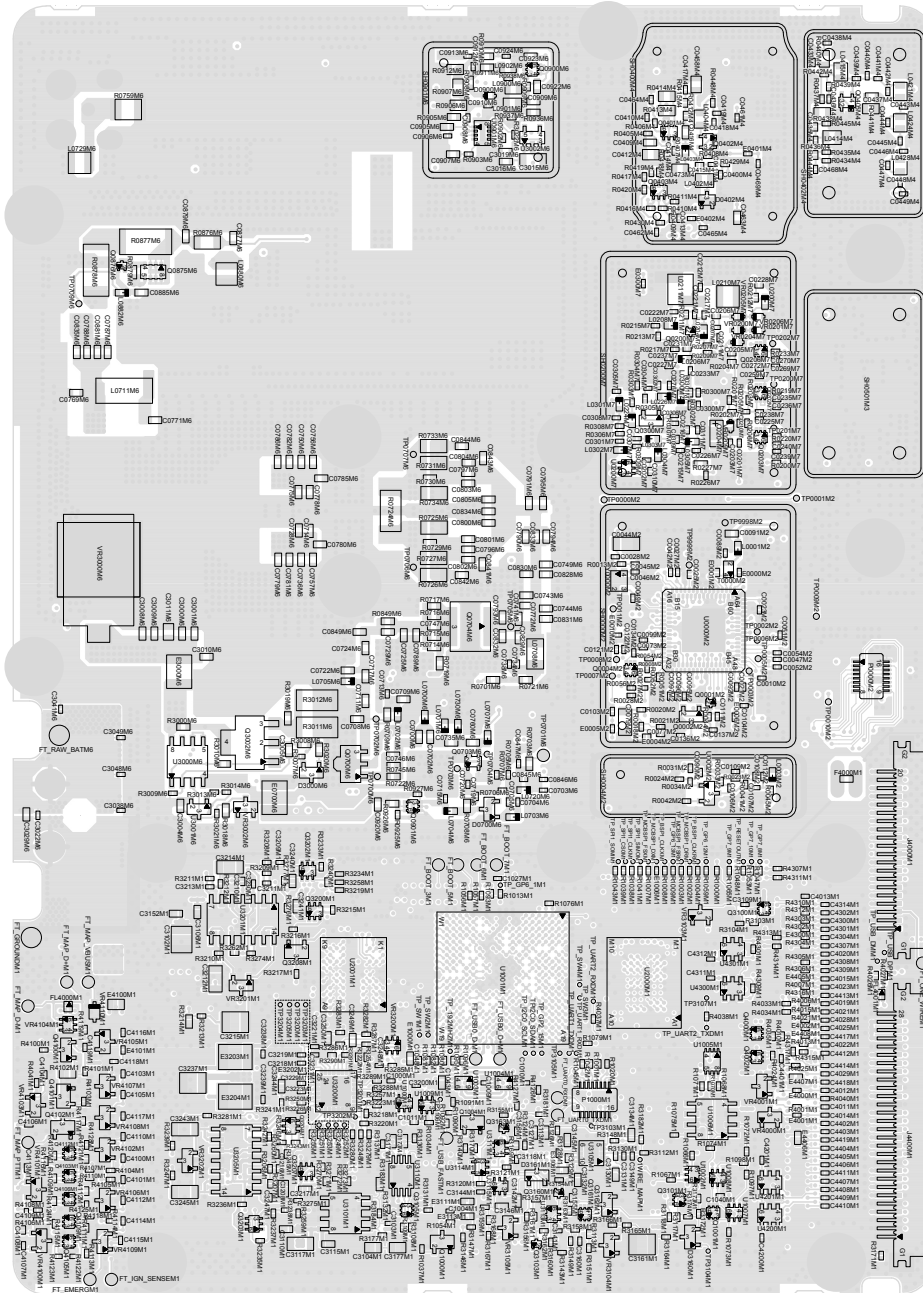

Figure 240: Overall Schematic Diagram

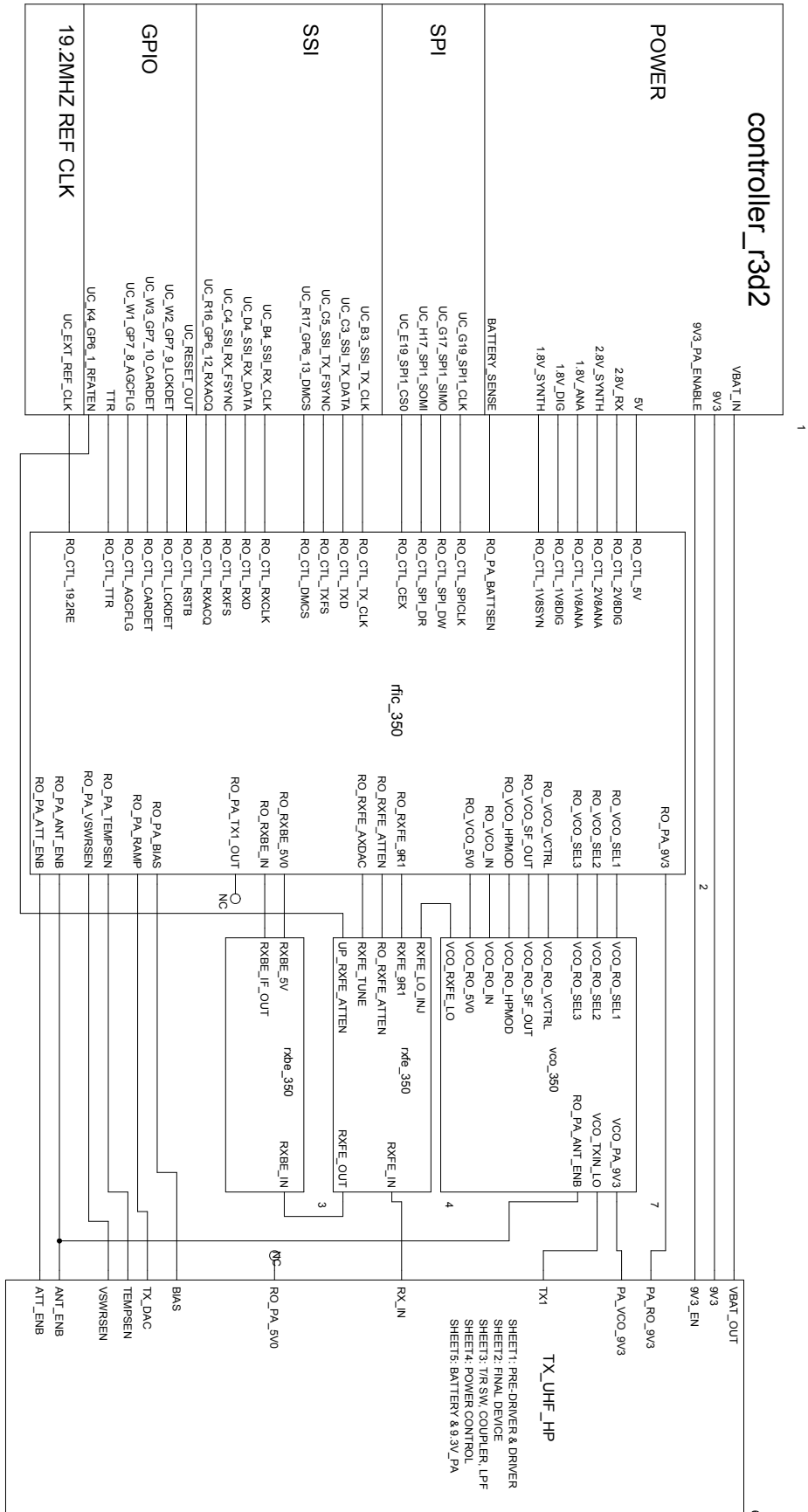

Figure 241: Receiver Front-End Schematic Diagram

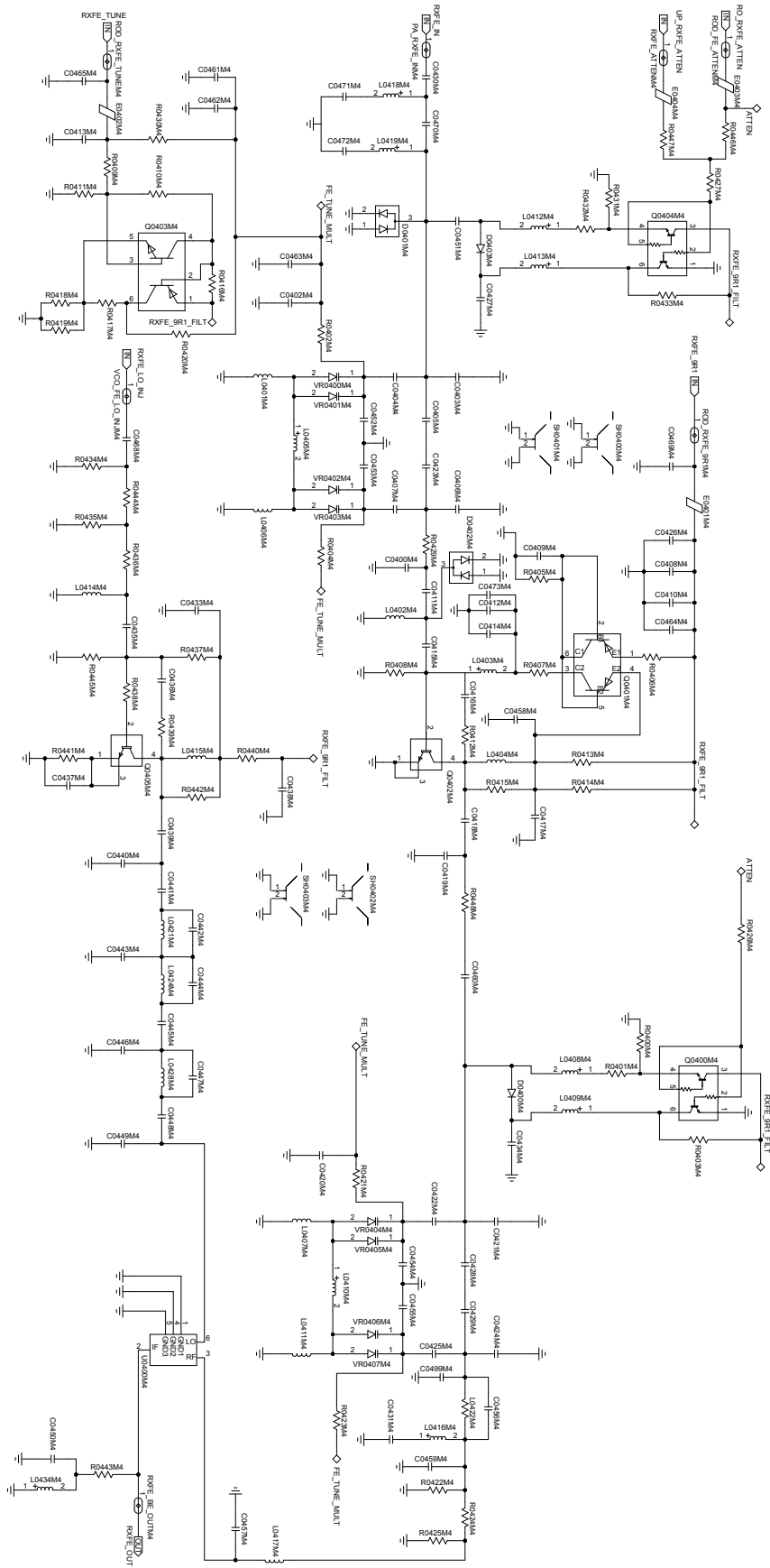

Figure 242: Receiver IF Amp Schematic Diagram

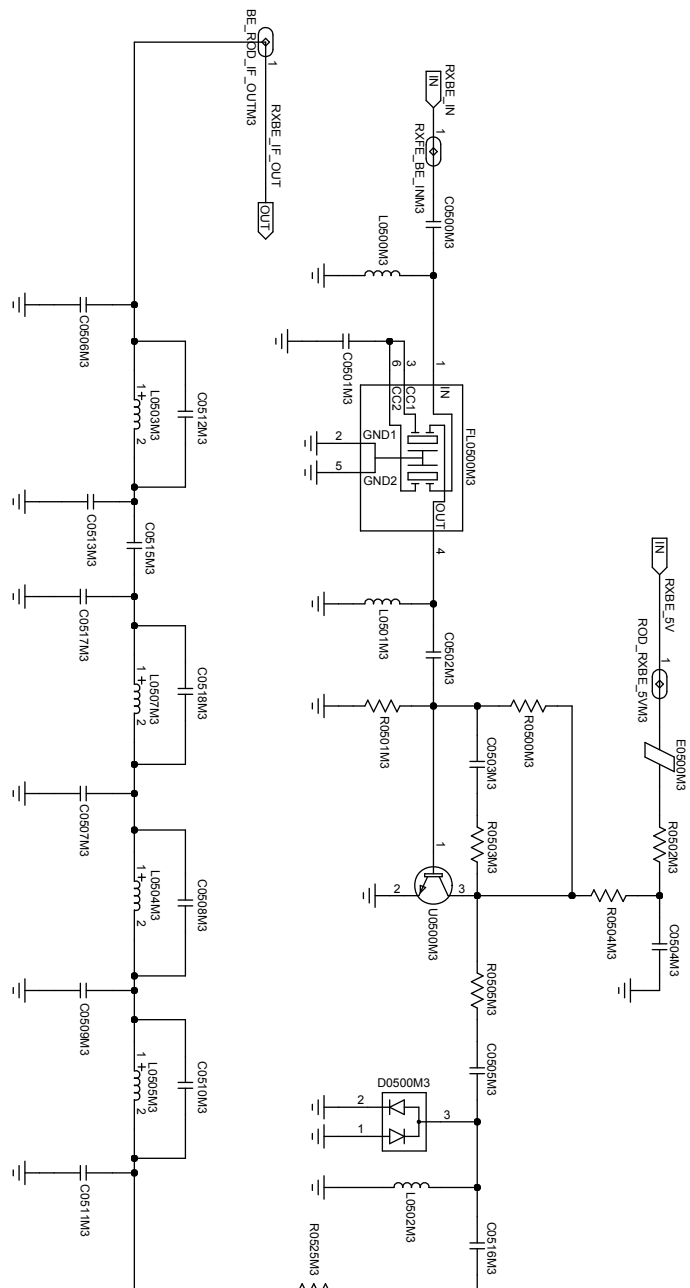
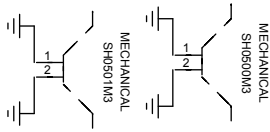

Figure 243: Transmit Power Amplifier Schematic Diagram (Sheet 1 of 3)

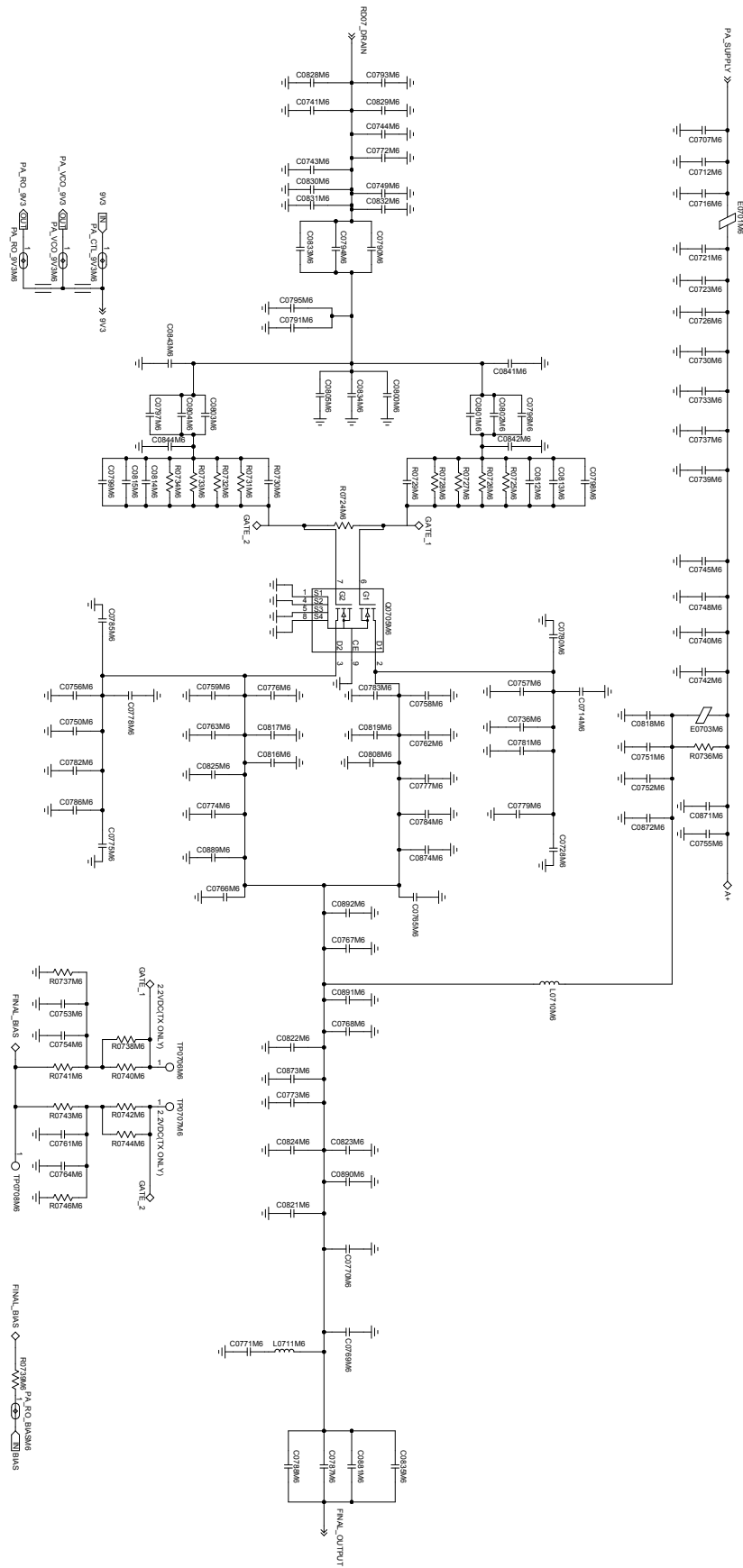

Figure 247: Transmit Power Amplifier DC Distribution Schematic Diagram

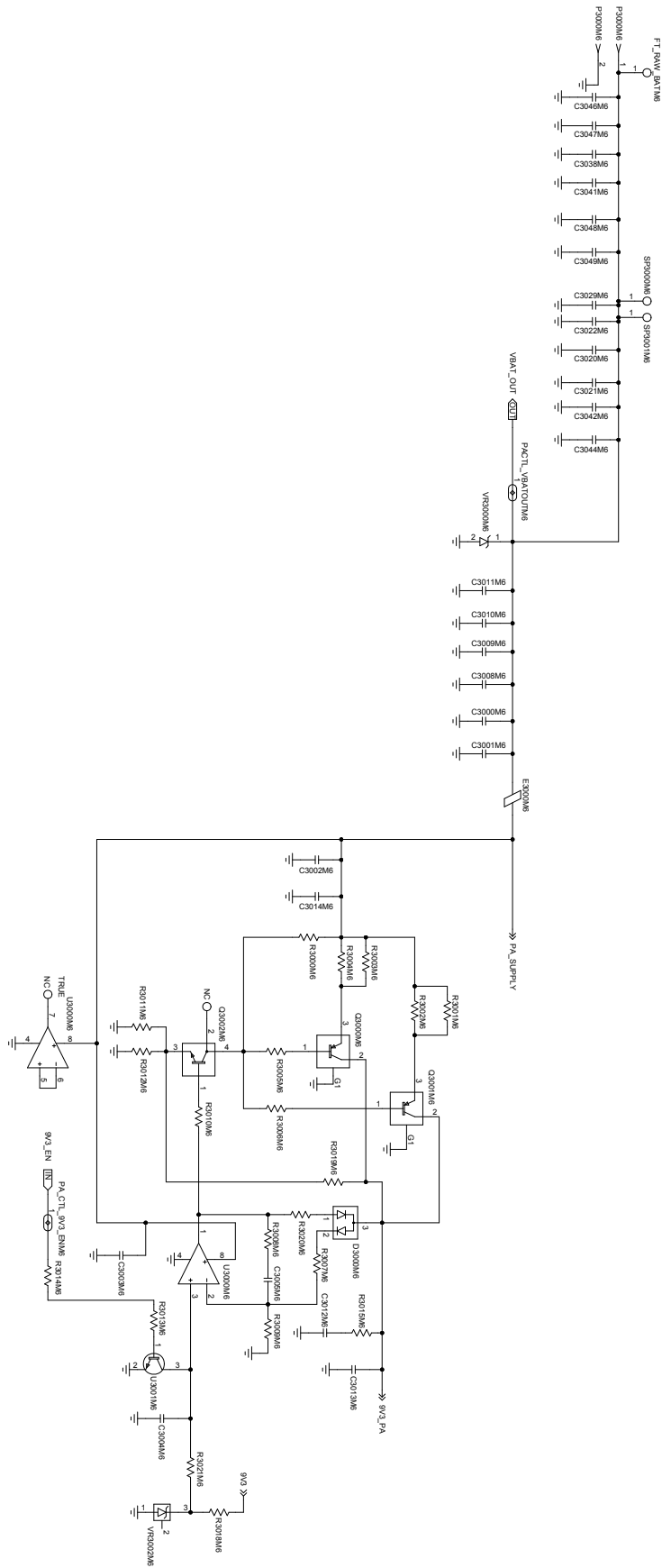

Figure 248: RFIC Schematic Diagram

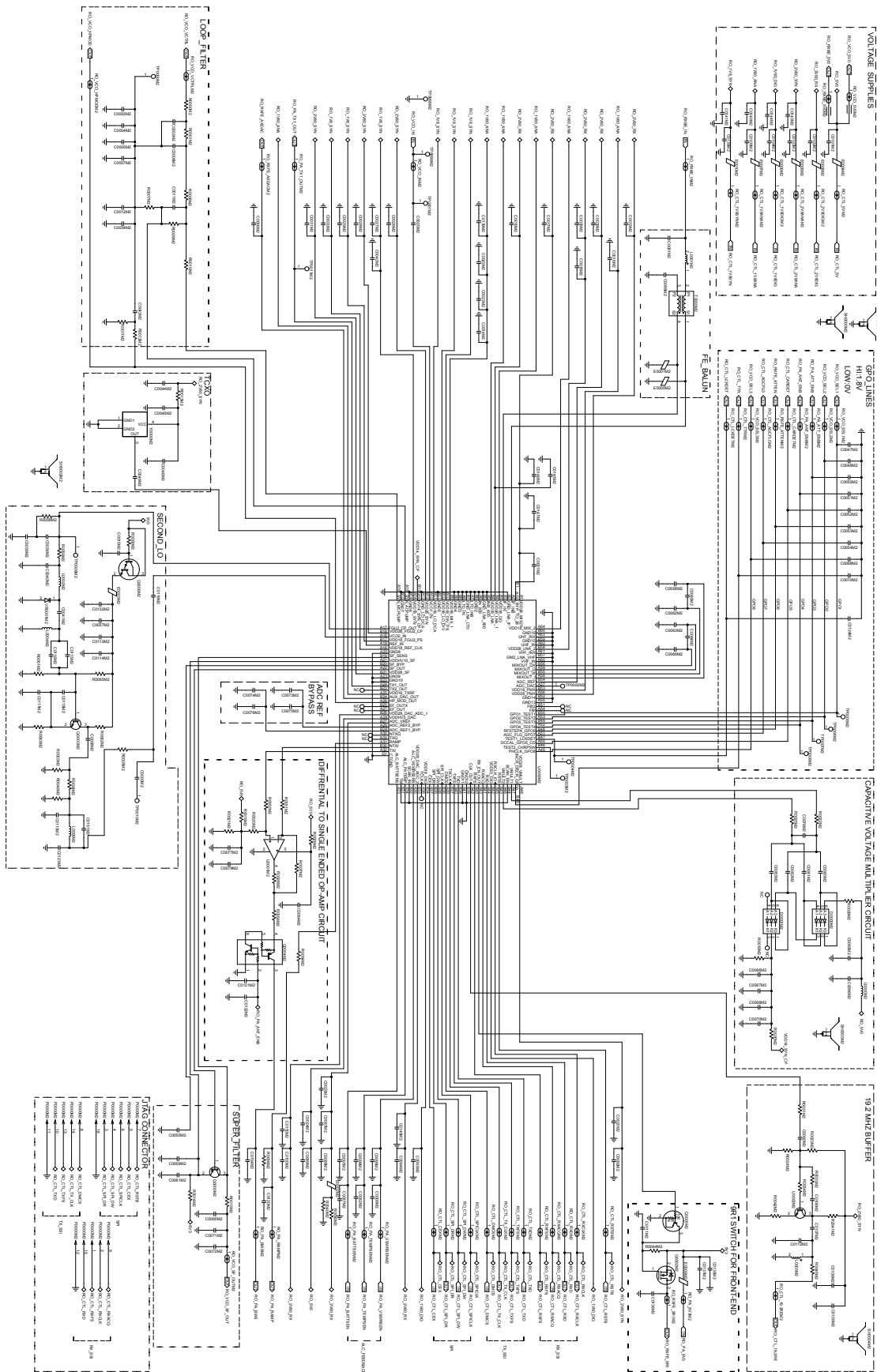

Figure 249: Receiver VCO Schematic Diagram

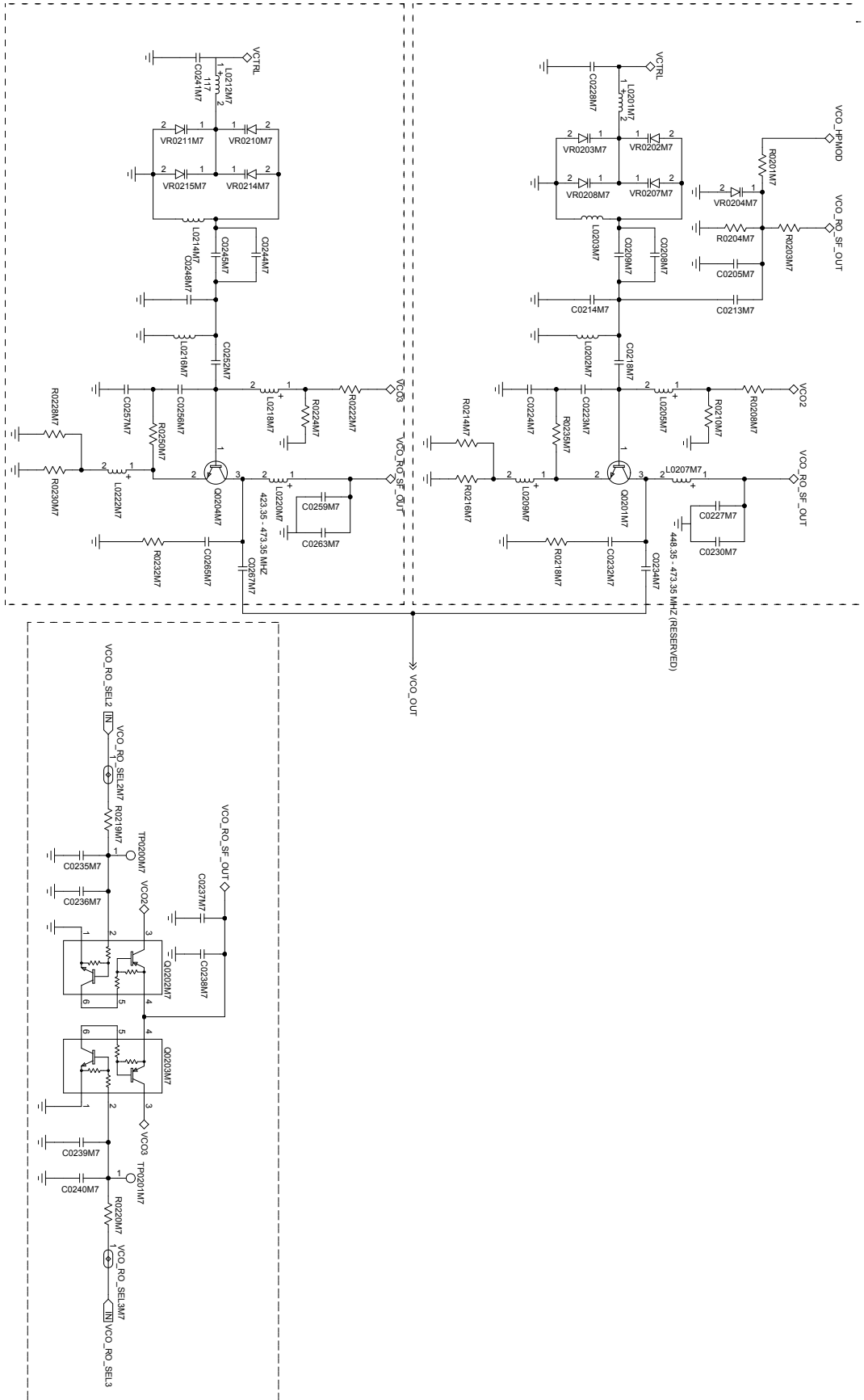

Figure 250: Transmit VCO Schematic Diagram

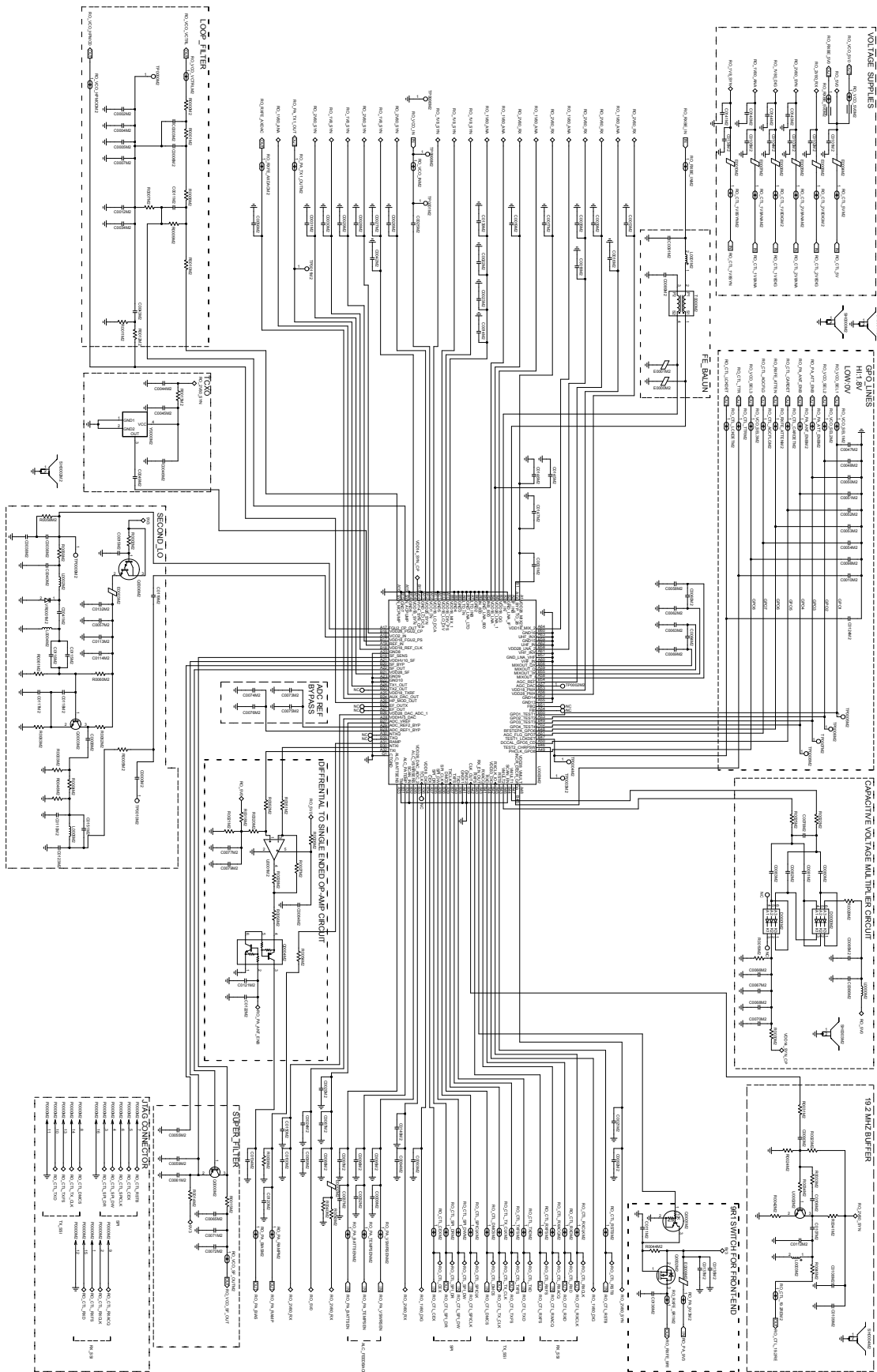
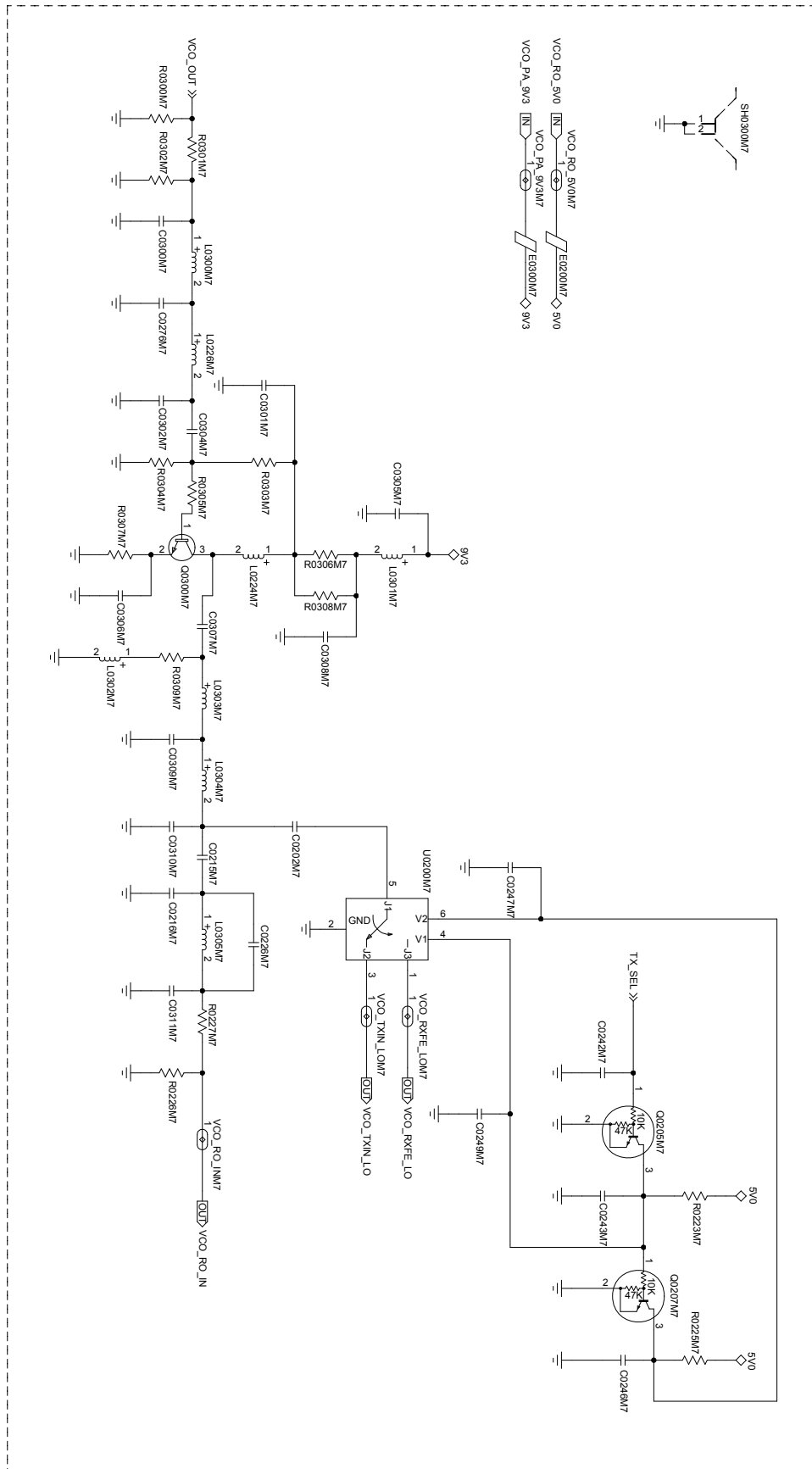

Figure 251: VCO Buffer Schematic Diagram



8.7.1.4

Parts List for 84012728003-C

Table 26: UHF2 Radio Parts List

Circuit Ref.	Motorola Solutions Part No.	Circuit Ref.	Motorola Solutions Part No.
C0000M2	21667009311	C3004M6	2113945C02
C0001M2	21667009170	C3005M6	2113945C02
C0002M2	NOT PLACED	C3008M6	2113944C51
C0003M2	NOT PLACED	C3009M6	2113945C31
C0004M2	21012044001	C3010M6	2113944C46
C0005M2	21012044001	C3011M6	NOT PLACED
C0006M2	2113945C31	C3012M6	2113946J04
C0007M2	21012044001	C3013M6	2113945C31
C0008M2	21667009311	C3014M6	21009337414
C0009M2	21667009166	C3015M6	2113946G01
C0010M2	21667009166	C3016M6	2113945C31
C0011M2	2113945C31	C3019M6	2113946S35
C0012M2	21012044001	C3020M6	2113945C26
C0013M2	2113945Y02	C3021M6	2113944C06
C0014M2	2113945Y02	C3022M6	2113945A10
C0015M2	2113946J03	C3029M6	NOT PLACED
C0016M2	2113945A10	C3038M6	21667009379
C0017M2	2113945Y02	C3041M6	21667009379
C0018M2	2113945A10	C3042M6	21667009379
C0019M2	2113945Y02	C3044M6	21667009379
C0020M2	2113945A10	C3046M6	NOT PLACED
C0021M2	2113945Y02	C3047M6	NOT PLACED
C0022M2	2113945Y02	C3048M6	NOT PLACED
C0023M2	2113945Y02	C3049M6	NOT PLACED
C0024M2	21012129001	D0000M2	4815011H01
C0025M2	21667009166	D0001M2	4815011H01
C0026M2	2113944A52	D0400M4	4884800Y03
C0027M2	2113945Y02	D0401M4	4813974A19
C0028M2	2113945Y02	D0402M4	4813974A19
C0029M2	2113945A10	D0403M4	4884800Y03
C0030M2	2113945A10	D0500M3	4813974A19
C0031M2	2113945Y02	D0700M6	CR001073A01

Circuit Ref.	Motorola Solutions Part No.	Circuit Ref.	Motorola Solutions Part No.
C0032M2	21667009166	D0875M6	48012160001
C0034M2	21012044001	D0876M6	4886622Y06
C0035M2	21667009166	D0877M6	48012160001
C0036M2	21012025001	D0900M6	48012181001
C0037M2	21667009166	D0950M6	4813974A21
C0038M2	21012044001	D0951M6	4813974A21
C0039M2	2113945Y02	D3000M6	4813978P07
C0040M2	2113945A10	E0000M2	24012095001
C0041M2	21667009364	E0001M2	24012095001
C0042M2	21667009166	E0002M2	NOT PLACED
C0043M2	21012044001	E0003M2	24012095001
C0044M2	2113955D45	E0004M2	24012095001
C0045M2	2113945Y02	E0005M2	24012095001
C0046M2	21667009166	E0006M2	24012095001
C0047M2	21667009166	E0007M2	24012095001
C0048M2	21667009166	E0008M2	24012095001
C0049M2	2113945B02	E0009M2	24012095001
C0050M2	21667009166	E0010M2	24012095001
C0051M2	21667009166	E0200M7	24012095001
C0052M2	21667009166	E0300M7	24012095001
C0053M2	21667009166	E0401M4	24012107027
C0054M2	21667009166	E0402M4	24012107027
C0055M2	2113955D37	E0403M4	24012107027
C0056M2	2113945Y02	E0404M4	24012107027
C0057M2	2113945B02	E0500M3	24012095001
C0058M2	NOT PLACED	E0700M6	24012102001
C0059M2	21667009166	E0701M6	24012102001
C0060M2	2113945A69	E0703M6	24012102001
C0061M2	2113945Y02	E3000M6	24012102001
C0062M2	NOT PLACED	FL0500M3	9116854H03
C0063M2	NOT PLACED	J0700M6	09009348002
C0064M2	2113945A69	L0000M2	IN000603A09
C0065M2	2113945Y02	L0001M2	24667001020
C0066M2	2113945B02	L0002M2	IN000658A01
C0067M2	2113945Y02	L0003M2	24667001031

Circuit Ref.	Motorola Solutions Part No.	Circuit Ref.	Motorola Solutions Part No.
C0068M2	2113955D37	L0004M2	24009343017
C0069M2	NOT PLACED	L0005M2	24667001017
C0070M2	2113955D37	L0200M7	24667001031
C0071M2	2113955D37	L0201M7	24667001031
C0072M2	21667009166	L0202M7	2415385H01
C0073M2	21667009166	L0203M7	24009343013
C0074M2	21667009166	L0204M7	24667001031
C0075M2	2113946S35	L0205M7	24667001031
C0076M2	2113946S35	L0206M7	24667001031
C0077M2	21667009166	L0207M7	24667001031
C0078M2	21667009372	L0208M7	24667001031
C0079M2	2113955D37	L0209M7	24667001031
C0080M2	2113945B02	L0210M7	24009343008
C0081M2	2113945B02	L0211M7	2415385H01
C0082M2	2113945B02	L0212M7	24667001031
C0083M2	2113945B02	L0214M7	24009343008
C0084M2	21667009166	L0216M7	2415385H01
C0085M2	21667009166	L0218M7	24667001031
C0086M2	2113945C31	L0220M7	24667001031
C0087M2	2113946S35	L0222M7	24667001031
C0088M2	2113945Y02	L0224M7	24667001030
C0089M2	2113945Y02	L0226M7	24667001018
C0090M2	2113945B02	L0300M7	24667001017
C0091M2	2113944C82	L0301M7	24667001031
C0092M2	21667009166	L0302M7	24667001031
C0093M2	2113945Y02	L0303M7	24667001021
C0094M2	2113945Y02	L0304M7	24667001017
C0095M2	2113945A13	L0305M7	24667001013
C0096M2	2113945B02	L0401M4	24012021001
C0097M2	2113945B02	L0402M4	24009344102
C0098M2	21667009166	L0403M4	24667001030
C0099M2	2113945Y02	L0404M4	24009344108
C0100M2	2113945Y02	L0405M4	24009315036
C0101M2	21667009166	L0406M4	24012021001
C0102M2	21667009166	L0407M4	24012021001

Circuit Ref.	Motorola Solutions Part No.	Circuit Ref.	Motorola Solutions Part No.
C0103M2	21667009166	L0408M4	24667001030
C0104M2	21667009166	L0409M4	24667001030
C0105M2	21667009166	L0410M4	24667001025
C0106M2	2113945B02	L0411M4	24012021001
C0107M2	2113945B02	L0412M4	24667001030
C0108M2	21667009166	L0413M4	24667001030
C0109M2	2113945Y02	L0414M4	24009344108
C0110M2	21667009381	L0415M4	24009344108
C0111M2	2113945Y02	L0416M4	24667001014
C0112M2	21667009166	L0417M4	24009344104
C0113M2	21667009166	L0418M4	NOT PLACED
C0114M2	2113945Y02	L0419M4	NOT PLACED
C0115M2	21667009366	L0421M4	24009344105
C0116M2	NOT PLACED	L0422M4	NOT PLACED
C0117M2	21667009374	L0424M4	24009344105
C0118M2	21667009382	L0428M4	24009344105
C0119M2	2113945A10	L0434M4	24667001021
C0120M2	21667009166	L0435M7	NOT PLACED
C0121M2	NOT PLACED	L0500M3	24009344127
C0122M2	21667009166	L0501M3	24009344128
C0123M2	21667009381	L0502M3	24009344126
C0124M2	21667009166	L0503M3	24667001021
C0132M2	2113946J03	L0504M3	24667001026
C0134M2	21667009166	L0505M3	24667001026
C0135M2	21667009166	L0507M3	24667001024
C0136M2	21667009166	L0700M6	NOT PLACED
C0137M2	2113945Y02	L0701M6	24667001014
C0138M2	21667009166	L0702M6	24667001028
C0139M2	21667009166	L0703M6	24667001028
C0140M2	2113945Y02	L0704M6	24667001028
C0141M2	2113945Y02	L0705M6	24667001007
C0143M2	2113945Y02	L0707M6	24667001028
C0144M2	2113945Y02	L0708M6	2479990G01
C0145M2	21667009166	L0709M6	NOT PLACED
C0146M2	2113945A10	L0710M6	2485873L01

Circuit Ref.	Motorola Solutions Part No.	Circuit Ref.	Motorola Solutions Part No.
C0147M2	2113945A10	L0711M6	NOT PLACED
C0149M2	21667009166	L0720M6	24667001013
C0150M2	21667009166	L0729M6	2414032B60
C0151M2	21667009368	L0730M6	24667001013
C0200M7	21667009166	L0850M6	2460592A01
C0201M7	NOT PLACED	L0851M6	2460592A01
C0202M7	21667009166	L0852M6	2460592A01
C0203M7	NOT PLACED	L0875M6	2460592A01
C0204M7	NOT PLACED	L0876M6	24667001029
C0205M7	21667009274	L0877M6	2414032B49
C0206M7	21667009332	L0878M6	24667001027
C0207M7	21667009320	L0880M6	2414032B49
C0208M7	21667009303	L0882M6	24667001027
C0209M7	21667009297	L0885M6	24667001014
C0210M7	NOT PLACED	L0900M6	24667000031
C0211M7	NOT PLACED	L0901M6	24009344018
C0212M7	21667009286	L0902M6	24667000031
C0213M7	21667009274	L0950M6	NOT PLACED
C0214M7	21667009303	L0951M6	24009344003
C0215M7	21667009332	L0952M6	24009344005
C0216M7	21667009303	M0700M6	2686201B02
C0217M7	21667009332	P0000M2	NOT PLACED
C0218M7	21667009315	P3000M6	9009344001
C0221M7	21667009355	Q0000M2	4813973A13
C0222M7	21667009366	Q0001M2	48009494001
C0223M7	21667009366	Q0002M2	4813970A59
C0224M7	21667009366	Q0003M2	4885316E32
C0225M7	2113945Y02	Q0004M2	4815272H01
C0226M7	21667009311	Q0006M2	4813973A04
C0227M7	2113945Y02	Q0200M7	4885316E32
C0228M7	21667009166	Q0201M7	4885316E32
C0229M7	21667009166	Q0202M7	4815272H01
C0230M7	21667009166	Q0203M7	4815272H01
C0231M7	21667009166	Q0204M7	4885316E32
C0232M7	21667009166	Q0205M7	48009494001

Circuit Ref.	Motorola Solutions Part No.	Circuit Ref.	Motorola Solutions Part No.
C0233M7	21667009284	Q0206M7	4815272H01
C0234M7	21667009284	Q0207M7	48009494001
C0235M7	21667009166	Q0300M7	4802197J95
C0236M7	2113945Y02	Q0400M4	4815271H01
C0237M7	21667009166	Q0401M4	4815267H01
C0238M7	2113945Y02	Q0402M4	48012201001
C0239M7	2113945Y02	Q0403M4	4815270H01
C0240M7	21667009166	Q0404M4	4815271H01
C0241M7	21667009166	Q0405M4	48012201001
C0242M7	21667009166	Q0700M6	CR001114A01
C0243M7	21667009166	Q0701M6	4816013H01
C0244M7	21667009297	Q0703M6	4802246J29
C0245M7	21667009326	Q0704M6	CR001116A01
C0246M7	21667009166	Q0705M6	CR001118A01
C0247M7	21667009166	Q0875M6	4813970A62
C0248M7	21667009364	Q0876M6	4816134H01
C0249M7	21667009166	Q0900M6	4815272H01
C0252M7	21667009294	Q0901M6	4815271H01
C0256M7	21667009366	Q3000M6	0105959T72
C0257M7	21667009370	Q3001M6	0105959T72
C0259M7	2113945Y02	Q3002M6	4813973B01
C0263M7	21667009166	R0000M2	0613952R66
C0265M7	21667009166	R0001M2	0613952R66
C0267M7	21667009286	R0002M2	0613952Q96
C0269M7	21667009166	R0003M2	0613952Q57
C0270M7	2113945Y02	R0004M2	0613952Q34
C0271M7	21667009166	R0005M2	0613952R66
C0272M7	2113945Y02	R0006M2	0613952Q25
C0276M7	21667009332	R0007M2	0613952Q54
C0277M7	NOT PLACED	R0008M2	0613952R01
C0278M7	NOT PLACED	R0009M2	0613952Q58
C0300M7	21667009303	R0010M2	0613952R66
C0301M7	NOT PLACED	R0011M2	0613952Q36
C0302M7	21667009303	R0012M2	0613952Q86
C0304M7	21667009390	R0013M2	0613952Q35

Circuit Ref.	Motorola Solutions Part No.	Circuit Ref.	Motorola Solutions Part No.
C0305M7	2113945Y02	R0014M2	0613952R66
C0306M7	2113945B02	R0015M2	0613952R66
C0307M7	21667009390	R0018M2	0613952Q80
C0308M7	2113945B02	R0019M2	0613952R01
C0309M7	21667009297	R0020M2	0613952R12
C0310M7	21667009282	R0021M2	0613952Q80
C0311M7	21667009364	R0022M2	0613952R66
C0400M4	NOT PLACED	R0023M2	0613952Q83
C0402M4	21667009166	R0024M2	0613952Q80
C0403M4	21667009274	R0025M2	0613952R66
C0404M4	21667009332	R0026M2	0613952R66
C0405M4	21667009005	R0027M2	0613952R12
C0406M4	21667009274	R0028M2	0613952R66
C0407M4	21667009332	R0029M2	0613952Q25
C0408M4	2113945C31	R0030M2	0613952R66
C0409M4	2113945C31	R0031M2	0613952R66
C0410M4	21667009166	R0033M2	0613952R01
C0411M4	21667009166	R0034M2	0613952Q57
C0412M4	2113946F05	R0040M2	0613952Q70
C0413M4	21667009166	R0041M2	0613952Q58
C0414M4	21667009166	R0042M2	0613952Q42
C0415M4	21667009368	R0043M2	0613952Q73
C0416M4	2113945C31	R0044M2	0613952R25
C0417M4	21667009166	R0045M2	0613952R66
C0418M4	21667009164	R0046M2	0613952Q57
C0419M4	21667009274	R0051M2	0613952R01
C0420M4	21667009166	R0052M2	0613952R01
C0421M4	21667009274	R0054M2	0613952M25
C0422M4	21667009320	R0056M2	0613952R66
C0423M4	21667009368	R0058M2	0613952Q74
C0424M4	21667009274	R0059M2	0613952R66
C0425M4	21667009320	R0060M2	0613952Q86
C0426M4	2113946F05	R0061M2	0613952Q85
C0427M4	21667009372	R0062M2	0613952Q61
C0428M4	21667009005	R0063M2	0613952Q64

Circuit Ref.	Motorola Solutions Part No.	Circuit Ref.	Motorola Solutions Part No.
C0429M4	21667009274	R0064M7	NOT PLACED
C0430M4	21667009161	R0200M7	0613952R66
C0431M4	21667009370	R0201M7	0613952R27
C0433M4	21667009166	R0202M7	NOT PLACED
C0434M4	21667009384	R0203M7	0613952R07
C0435M4	21667009372	R0204M7	0613952R05
C0436M4	21667009166	R0205M7	NOT PLACED
C0437M4	2113945C31	R0206M7	NOT PLACED
C0438M4	21667009166	R0207M7	0613952Q84
C0439M4	21667009364	R0208M7	0613952Q86
C0440M4	21667009291	R0209M7	0613952Q85
C0441M4	21667009339	R0210M7	0613952Q85
C0442M4	21667009286	R0211M7	21667009380
C0443M4	21667009346	R0212M7	0613952Q32
C0444M4	21667009274	R0213M7	0613952Q67
C0445M4	21667009392	R0214M7	0613952Q67
C0446M4	21667009346	R0215M7	0613952Q67
C0447M4	21667009282	R0216M7	0613952Q67
C0448M4	21667009339	R0217M7	0613952Q49
C0449M4	21667009291	R0218M7	0613952Q49
C0450M4	21667009388	R0219M7	0613952R66
C0451M4	21667009166	R0220M7	0613952R66
C0452M4	21667009339	R0221M7	0613952R66
C0453M4	21667009339	R0222M7	0613952Q83
C0454M4	21667009346	R0223M7	0613952Q73
C0455M4	21667009346	R0224M7	0613952Q85
C0456M4	21667009366	R0225M7	0613952Q73
C0457M4	21667009186	R0226M7	0613952Q17
C0458M4	2113946F05	R0227M7	0613952A51
C0459M4	21667009355	R0228M7	0613952Q67
C0460M4	21667009384	R0230M7	0613952Q67
C0461M4	NOT PLACED	R0232M7	0613952Q49
C0462M4	21667009159	R0233M7	0613952R66
C0463M4	NOT PLACED	R0234M7	NOT PLACED
C0464M4	21667009158	R0235M7	0613952Q18

Circuit Ref.	Motorola Solutions Part No.	Circuit Ref.	Motorola Solutions Part No.
C0465M4	21667009166	R0250M7	21667009383
C0468M4	21667009166	R0300M7	0613952Q66
C0469M4	21667009166	R0301M7	0613952Q25
C0470M4	21667009380	R0302M7	0613952Q66
C0471M4	NOT PLACED	R0303M7	0613952R05
C0472M4	NOT PLACED	R0304M7	0613952Q89
C0473M4	NOT PLACED	R0305M7	0613952Q33
C0499M4	NOT PLACED	R0306M7	0613952Q32
C0500M3	21667009369	R0307M7	0613952Q49
C0501M3	21667009332	R0308M7	0613952Q32
C0502M3	2113944M21	R0309M7	0613952Q42
C0503M3	2113945C31	R0400M4	0613952R01
C0504M3	2113945C31	R0401M4	0613952H73
C0505M3	21667011351	R0402M4	0613952R25
C0506M3	NOT PLACED	R0403M4	0613952R01
C0507M3	21667009374	R0404M4	0613952R25
C0508M3	21667009366	R0405M4	0613952Q76
C0509M3	21667009382	R0406M4	0613952Q89
C0510M3	21667009366	R0407M4	0613952Q73
C0511M3	21667009355	R0408M4	0613952Q75
C0512M3	21667009303	R0409M4	0613952Q69
C0513M3	21667009368	R0410M4	0613952R01
C0515M3	21667009383	R0411M4	0613952R01
C0516M3	21667011464	R0412M4	0613952Q89
C0517M3	21667009315	R0413M4	0613958H58
C0518M3	21667009339	R0414M4	NOT PLACED
C0700M6	2113944C45	R0415M4	0613952Q46
C0701M6	2113944A41	R0416M4	0613952Q69
C0702M6	2113944C38	R0417M4	0613952Q69
C0703M6	21667009163	R0418M4	0613952Q69
C0704M6	2113944A41	R0419M4	0613952Q69
C0705M6	2113944A41	R0420M4	0613952R25
C0706M6	NOT PLACED	R0421M4	0613952R25
C0707M6	2113944C82	R0422M4	0613952Q67
C0708M6	2113944C30	R0423M4	0613952R25

Circuit Ref.	Motorola Solutions Part No.	Circuit Ref.	Motorola Solutions Part No.
C0709M6	2113945C04	R0424M4	0613952Q23
C0710M6	2113944A41	R0425M4	0613952Q67
C0711M6	2113944C47	R0426M4	0613952Q87
C0712M6	2113945C04	R0427M4	0613952Q93
C0713M6	2113944A41	R0429M4	0613952R66
C0714M6	21012094097	R0430M4	NOT PLACED
C0715M6	2113944A41	R0431M4	0613952R01
C0716M6	2113944C55	R0432M4	0613952H73
C0717M6	2113944C39	R0433M4	0613952R01
C0718M6	NOT PLACED	R0434M4	0613952L46
C0719M6	2113944A41	R0435M4	0613952L46
C0720M6	2113944A37	R0436M4	0613952R66
C0721M6	2113944C82	R0437M4	0613952Q77
C0722M6	NOT PLACED	R0438M4	0613958H22
C0723M6	2113945C04	R0439M4	0613952Q83
C0724M6	2113944C34	R0440M4	0613958H25
C0725M6	NOT PLACED	R0441M4	0613958B89
C0726M6	2113944C51	R0442M4	0613952Q83
C0727M6	NOT PLACED	R0443M4	0613952Q25
C0728M6	NOT PLACED	R0444M4	0613952K25
C0729M6	NOT PLACED	R0445M4	0613952Q75
C0730M6	NOT PLACED	R0446M4	NOT PLACED
C0731M6	2113944A41	R0447M4	0613952R66
C0732M6	2113945A09	R0448M4	0613952Q28
C0733M6	NOT PLACED	R0500M3	0613952Q87
C0734M6	2113945A09	R0501M3	0613952R19
C0735M6	21012094093	R0502M3	0613952Q66
C0736M6	NOT PLACED	R0503M3	0613952Q88
C0737M6	2113944C51	R0504M3	0613952Q61
C0738M6	2113944A41	R0505M3	0613952R66
C0739M6	2113945C31	R0525M3	0613952R66
C0740M6	2113944C51	R0700M6	0613952H90
C0741M6	2113944C82	R0701M6	0613952G67
C0742M6	2113945L49	R0702M6	0613952H89
C0743M6	2113944C35	R0703M6	0613952J01

Circuit Ref.	Motorola Solutions Part No.	Circuit Ref.	Motorola Solutions Part No.
C0744M6	2113944C34	R0704M6	0613952J10
C0745M6	2113946J04	R0705M6	0613952Q46
C0746M6	NOT PLACED	R0706M6	0613952Q58
C0747M6	2113944C45	R0707M6	0613952Q46
C0748M6	NOT PLACED	R0708M6	0613952H44
C0749M6	2113944C83	R0709M6	NOT PLACED
C0750M6	NOT PLACED	R0711M6	0613958S44
C0751M6	NOT PLACED	R0712M6	0613958S44
C0752M6	2113944C85	R0713M6	NOT PLACED
C0753M6	2113944C51	R0714M6	0613952H09
C0754M6	2113944C45	R0715M6	0613952H09
C0755M6	2113944C85	R0716M6	0613952H09
C0756M6	NOT PLACED	R0717M6	0613952H09
C0757M6	NOT PLACED	R0718M6	0613952J05
C0758M6	21667003042	R0719M6	0613952H89
C0759M6	21667003042	R0720M6	0613952H95
C0760M6	2113944C45	R0721M6	0613952G67
C0761M6	2113944C45	R0722M6	0613952H32
C0762M6	21012094096	R0723M6	0613952G67
C0763M6	21012094096	R0724M6	NOT PLACED
C0764M6	2113944C51	R0725M6	0613958S29
C0765M6	21667003033	R0726M6	NOT PLACED
C0766M6	21667003033	R0727M6	0613958S29
C0767M6	NOT PLACED	R0728M6	NOT PLACED
C0768M6	NOT PLACED	R0729M6	NOT PLACED
C0769M6	NOT PLACED	R0730M6	NOT PLACED
C0770M6	21667003029	R0731M6	0613958S29
C0771M6	NOT PLACED	R0732M6	NOT PLACED
C0772M6	2113944C35	R0733M6	NOT PLACED
C0773M6	NOT PLACED	R0734M6	0613958S29
C0774M6	NOT PLACED	R0736M6	0613959Q25
C0775M6	NOT PLACED	R0737M6	0613952F01
C0776M6	21667003038	R0738M6	0613959Q53
C0777M6	21012094097	R0739M6	0613952H73
C0778M6	21012094097	R0740M6	NOT PLACED

Circuit Ref.	Motorola Solutions Part No.	Circuit Ref.	Motorola Solutions Part No.
C0779M6	NOT PLACED	R0741M6	0613952E66
C0780M6	21012094093	R0742M6	NOT PLACED
C0781M6	NOT PLACED	R0743M6	0613952E66
C0782M6	NOT PLACED	R0744M6	0613959Q53
C0783M6	21667003038	R0745M6	NOT PLACED
C0784M6	NOT PLACED	R0746M6	0613952F01
C0785M6	21012094093	R0759M6	0613959H12
C0786M6	NOT PLACED	R0849M6	0613952G67
C0787M6	21012094048	R0876M6	0613958S73
C0788M6	21012094048	R0877M6	0613959Y37
C0789M6	2113944C36	R0878M6	0613959Y37
C0790M6	2113944C82	R0879M6	0613952J25
C0791M6	21667011042	R0883M6	0613952G67
C0792M6	21012094089	R0902M6	0613952R66
C0793M6	2113944C32	R0903M6	0613952N01
C0794M6	2113944C82	R0904M6	0613952R66
C0795M6	21667011042	R0905M6	0613952H42
C0796M6	2113944C39	R0906M6	0613958H46
C0797M6	2113944C39	R0907M6	0613958H55
C0798M6	2113944C38	R0908M6	0613952H42
C0799M6	2113944C38	R0909M6	NOT PLACED
C0800M6	2113944C32	R0910M6	0613952H91
C0801M6	2113944C38	R0911M6	0613952H85
C0802M6	2113944C38	R0912M6	0613958H46
C0803M6	2113944C38	R0913M6	0613952M51
C0804M6	2113944C38	R0914M6	0613952M71
C0805M6	2113944C32	R0915M6	NOT PLACED
C0806M6	21012094089	R0916M6	0613952R66
C0807M6	21012094092	R0917M6	0613952P01
C0808M6	21012094097	R0919M6	0613952P01
C0809M6	21012094092	R0920M6	0613952N01
C0810M6	21012094048	R0921M6	0613952N01
C0811M6	21012094048	R0922M6	0613952R66
C0812M6	2113944C38	R0923M6	0613952M30
C0813M6	2113944C38	R0924M6	0613952N01

Circuit Ref.	Motorola Solutions Part No.	Circuit Ref.	Motorola Solutions Part No.
C0814M6	2113944C38	R0925M6	0613952Q59
C0815M6	2113944C38	R0926M6	0613952H79
C0816M6	21012094097	R0927M6	0613952N01
C0817M6	21667003033	R0928M6	0613952P18
C0818M6	NOT PLACED	R0929M6	0613952N85
C0819M6	21667003033	R0930M6	0613952N37
C0820M6	21012094092	R0931M6	0613952M77
C0821M6	NOT PLACED	R0932M6	0613952N43
C0822M6	NOT PLACED	R0933M6	0613952M37
C0823M6	NOT PLACED	R0934M6	0613952J17
C0824M6	21012094089	R0935M6	0613952H91
C0825M6	21012094097	R0936M6	0613952H91
C0826M6	21667011491	R0937M6	NOT PLACED
C0827M6	21667011491	R0938M6	NOT PLACED
C0828M6	2113944C35	R0939M6	0613952R66
C0829M6	2113944C82	R0940M6	0613952Z76
C0830M6	2113944C84	R0941M6	0613952N58
C0831M6	2113944C34	R0942M6	0613952N58
C0832M6	2113944C32	R0943M6	0613952N58
C0833M6	2113944C82	R0950M6	0613952G67
C0834M6	2113944C33	R0951M6	0613958M21
C0835M6	21012094048	R0952M6	0613958M21
C0836M6	2113944C90	R0953M6	0613952G67
C0837M6	NOT PLACED	R0954M6	0613952H58
C0838M6	21012094085	R0955M6	0613952H58
C0839M6	21667011146	R0956M6	0613952H67
C0840M6	21012094085	R0957M6	0613958C18
C0841M6	2113944C37	R0958M6	0613958C18
C0842M6	NOT PLACED	R0959M6	0613952R66
C0843M6	2113944C37	R0960M6	0613952N58
C0844M6	NOT PLACED	R0961M6	0613952N58
C0845M6	21667009291	R0962M6	0613952N58
C0846M6	21667009320	R0965M6	NOT PLACED
C0847M6	21667009320	R0966M6	NOT PLACED
C0848M6	2113944C45	R0980M6	0613952N43

Circuit Ref.	Motorola Solutions Part No.	Circuit Ref.	Motorola Solutions Part No.
C0849M6	2113944C08	R0981M6	0613952P01
C0850M6	21012094085	R3000M6	0613952H60
C0851M6	21012094089	R3001M6	0615871H01
C0852M6	21012094086	R3002M6	0615871H01
C0853M6	21012094092	R3003M6	0615871H01
C0854M6	21012094090	R3004M6	0615871H01
C0855M6	21012094090	R3005M6	0613952H25
C0856M6	21012094048	R3006M6	0613952H25
C0857M6	21012094089	R3007M6	0613952M30
C0858M6	NOT PLACED	R3008M6	0613952G67
C0859M6	21012094086	R3009M6	0613952M43
C0860M6	21012094086	R3010M6	0613952G67
C0861M6	21012094092	R3011M6	0613959Q60
C0862M6	21012094092	R3012M6	0613959Q60
C0863M6	21012094092	R3013M6	0613952R01
C0864M6	21012094092	R3014M6	0613952R01
C0865M6	NOT PLACED	R3015M6	0615871H01
C0866M6	21012094090	R3018M6	0613952H73
C0867M6	21012094090	R3019M6	0613952H60
C0868M6	21012094082	R3020M6	0613952G67
C0869M6	21012094090	R3021M6	0613952R25
C0870M6	21012094048	R3022M6	0613952R66
C0871M6	2113944C85	R3023M6	NOT PLACED
C0872M6	2113944C85	RT0900M6	0615585H01
C0873M6	21667003028	SH0000M2	26012095001
C0874M6	NOT PLACED	SH0001M2	26012095001
C0875M6	2113944C46	SH0002M2	26012097001
C0876M6	NOT PLACED	SH0003M2	26012094001
C0877M6	2113944C42	SH0004M2	26012094001
C0878M6	NOT PLACED	SH0200M7	26012095001
C0879M6	2113944C42	SH0300M7	26012095001
C0880M6	21667003028	SH0400M4	26012096001
C0881M6	21012094048	SH0401M4	26012096001
C0882M6	21667011146	SH0402M4	26012098001
C0883M6	21667011491	SH0403M4	26012098001

Circuit Ref.	Motorola Solutions Part No.	Circuit Ref.	Motorola Solutions Part No.
C0884M6	2113944F15	SH0500M3	26012098001
C0885M6	2113944C51	SH0501M3	NOT PLACED
C0886M6	2113944C47	SH0850M6	26012100001
C0887M6	21012094082	SH0900M6	2686425Z02
C0888M6	21012094102	SH0901M6	2686425Z02
C0889M6	NOT PLACED	SP3000M6	NOT PLACED
C0890M6	NOT PLACED	SP3001M6	NOT PLACED
C0891M6	21667003028	T0000M2	24012146001
C0892M6	NOT PLACED	U0000M2	51009877001
C0900M6	NOT PLACED	U0001M2	5109731C48
C0901M6	NOT PLACED	U0002M2	4802197J95
C0902M6	2113944C51	U0200M7	5186310Y39
C0905M6	2113945C31	U0400M4	HZ000490A01
C0906M6	2113945A10	U0500M3	4802197J95
C0907M6	2113945L41	U0901M6	5180390L83
C0908M6	21667009166	U0902M6	51012221001
C0909M6	2113944C02	U0903M6	5115022H01
C0910M6	21667009166	U0904M6	5109731C48
C0911M6	2113944C02	U0905M6	5109731C48
C0912M6	21667009166	U3000M6	5116525H01
C0913M6	21667009166	U3001M6	4813973M07
C0916M6	NOT PLACED	U3002M6	51012133001
C0917M6	21667009166	VR0001M2	4815096H01
C0918M6	21667009166	VR0200M7	CR000291A01
C0919M6	21667009166	VR0201M7	CR000291A01
C0920M6	2113944C02	VR0202M7	CR000291A01
C0921M6	2113944C02	VR0203M7	CR000291A01
C0922M6	2113945C31	VR0204M7	CR000291A01
C0923M6	2113944C02	VR0205M7	CR000291A01
C0924M6	21667009166	VR0206M7	CR000291A01
C0925M6	2113945C31	VR0207M7	CR000291A01
C0926M6	2113944C02	VR0208M7	CR000291A01
C0927M6	2113944C01	VR0209M7	NOT PLACED
C0928M6	2113944C51	VR0210M7	CR000291A01
C0929M6	2113944C49	VR0211M7	CR000291A01

Circuit Ref.	Motorola Solutions Part No.	Circuit Ref.	Motorola Solutions Part No.
C0930M6	NOT PLACED	VR0214M7	CR000291A01
C0931M6	2113944C02	VR0215M7	CR000291A01
C0950M6	2113944C47	VR0400M4	CR000291A01
C0951M6	21667011356	VR0401M4	CR000291A01
C0952M6	2113944C47	VR0402M4	CR000291A01
C0953M6	2113944C47	VR0403M4	CR000291A01
C0954M6	21667011351	VR0404M4	CR000291A01
C0955M6	2113944C47	VR0405M4	CR000291A01
C0956M6	2113944C01	VR0406M4	CR000291A01
C0957M6	2113944C49	VR0407M4	CR000291A01
C3000M6	2113944C38	VR3000M6	48012202001
C3001M6	2113944C06	VR3002M6	4813977M10
C3002M6	2113944C06	Y0000M2	4875185M05
C3003M6	2113945C31	-	-



NOTICE: The suffix "M1", "M2", and so on from the Circuit Ref. is removed from the schematic and overlays.

8.8

800/900 Band Service Information

8.8.1

Allocation of Schematics and Circuit Boards

This chapter shows the schematics for the 800/900 Band circuits. The PCB component layouts and the Parts List in this chapter show both the Controller and 800/900 Band circuit components.

800/900 Band Schematic Diagrams and Parts List for 84012657001-A

Diagrams:

- [Figure 252: Main Board Top Side PCB No. 84012657001-A on page 532](#)
- [Figure 253: Main Board Bottom Side PCB No. 84012657001-A on page 533](#)
- [Figure 254: Overall Schematic Diagram on page 534](#)
- [Figure 255: Receiver Front-End Schematic Diagram on page 535](#)
- [Figure 256: Receiver IF Amp Schematic Diagram on page 536](#)
- [Figure 257: Transmitter Power Amplifier Schematic Diagram on page 537](#)
- [Figure 258: Power Control Schematic Diagram on page 538](#)
- [Figure 259: Transmitter Power Amplifier DC Distribution Schematic Diagram on page 539](#)
- [Figure 260: RFIC Schematic Diagram on page 540](#)
- [Figure 261: VCO Schematic Diagram on page 541](#)

Figure 254: Overall Schematic Diagram

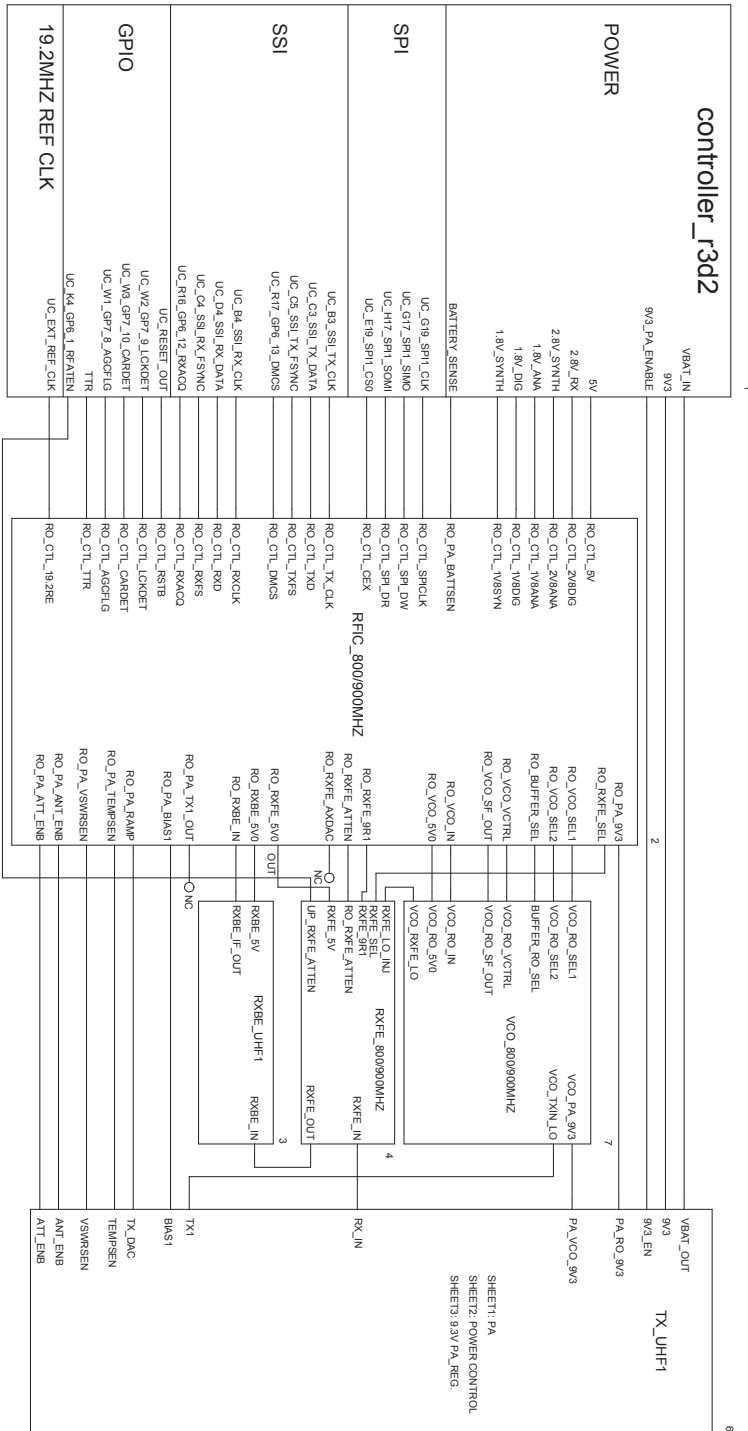

Figure 255: Receiver Front-End Schematic Diagram

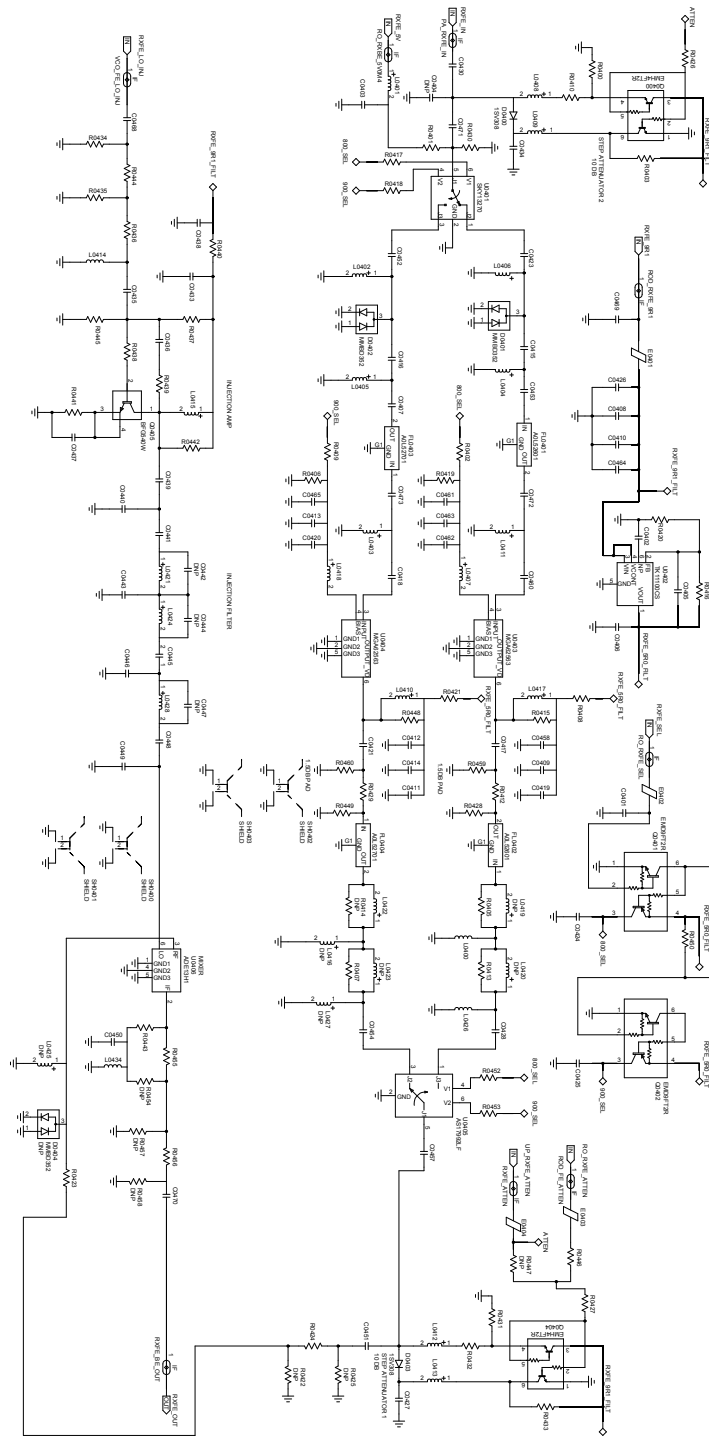

Figure 257: Transmitter Power Amplifier Schematic Diagram

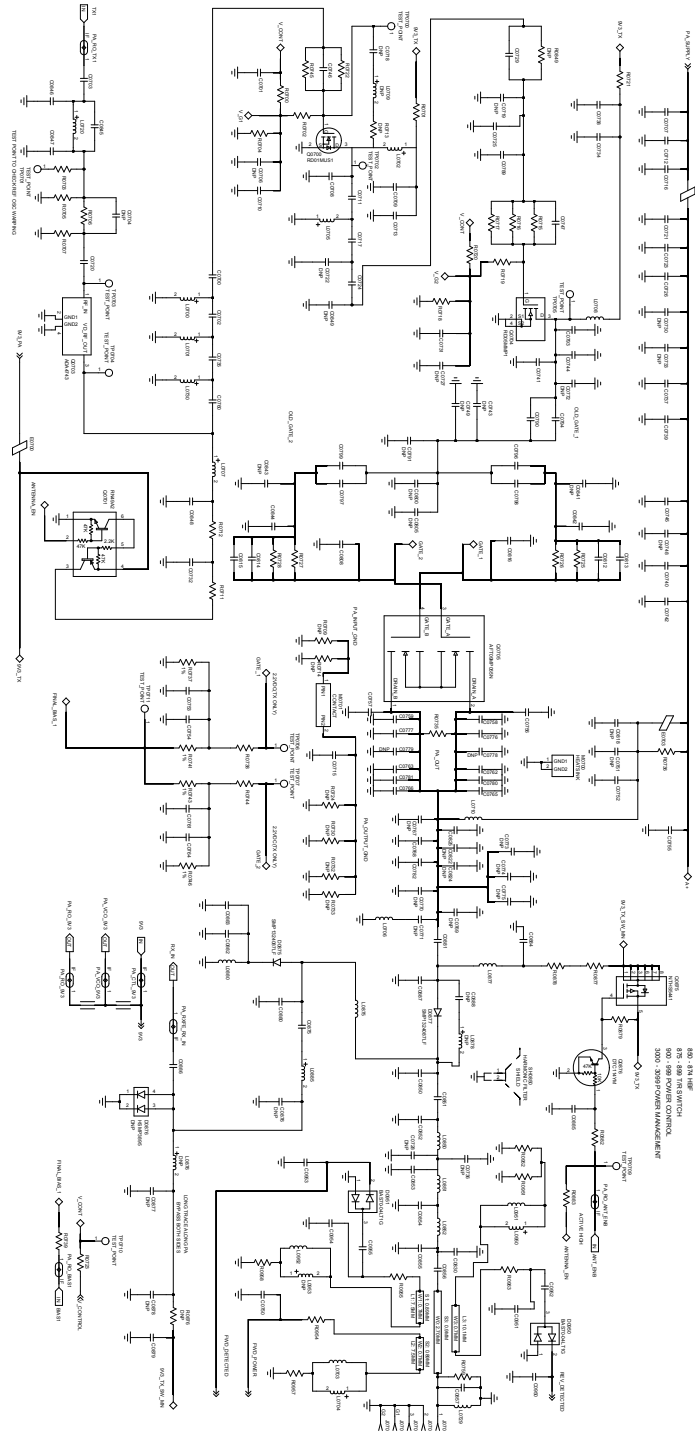

Figure 258: Power Control Schematic Diagram

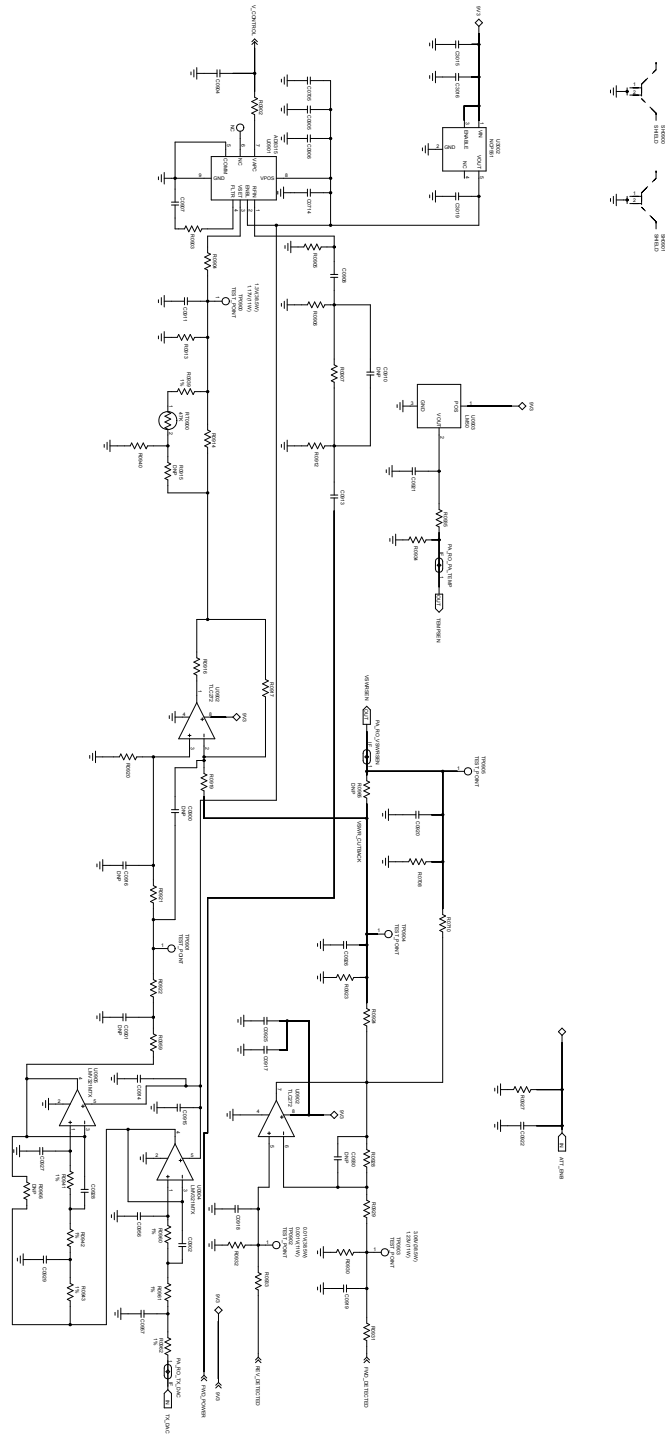

Figure 259: Transmitter Power Amplifier DC Distribution Schematic Diagram

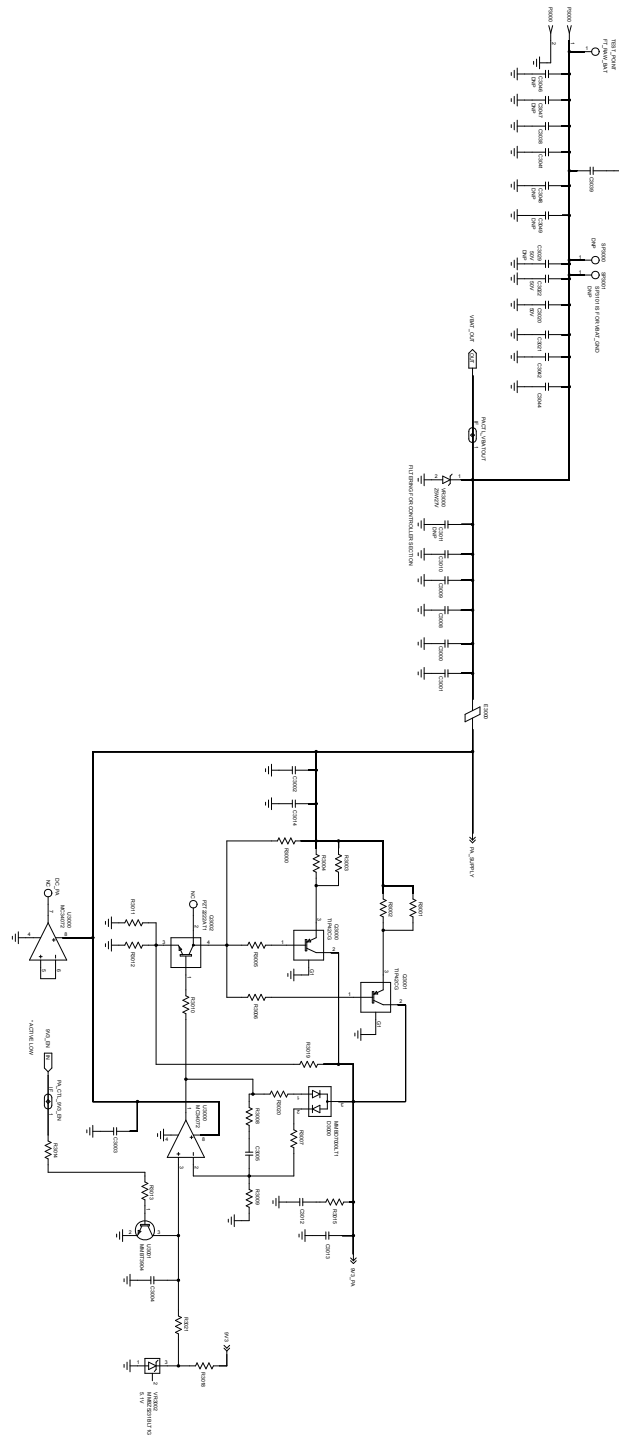

Figure 260: RFIC Schematic Diagram

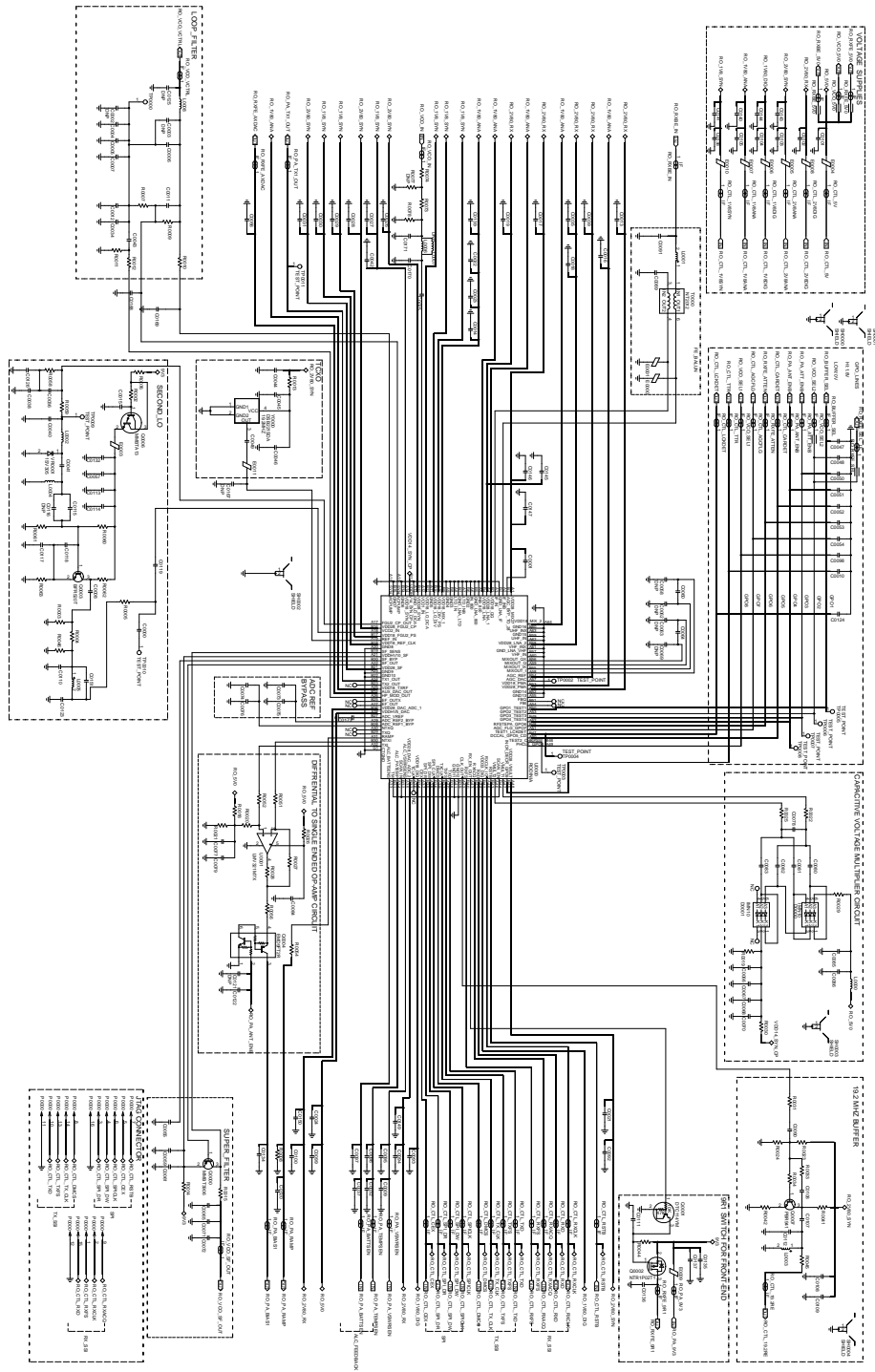
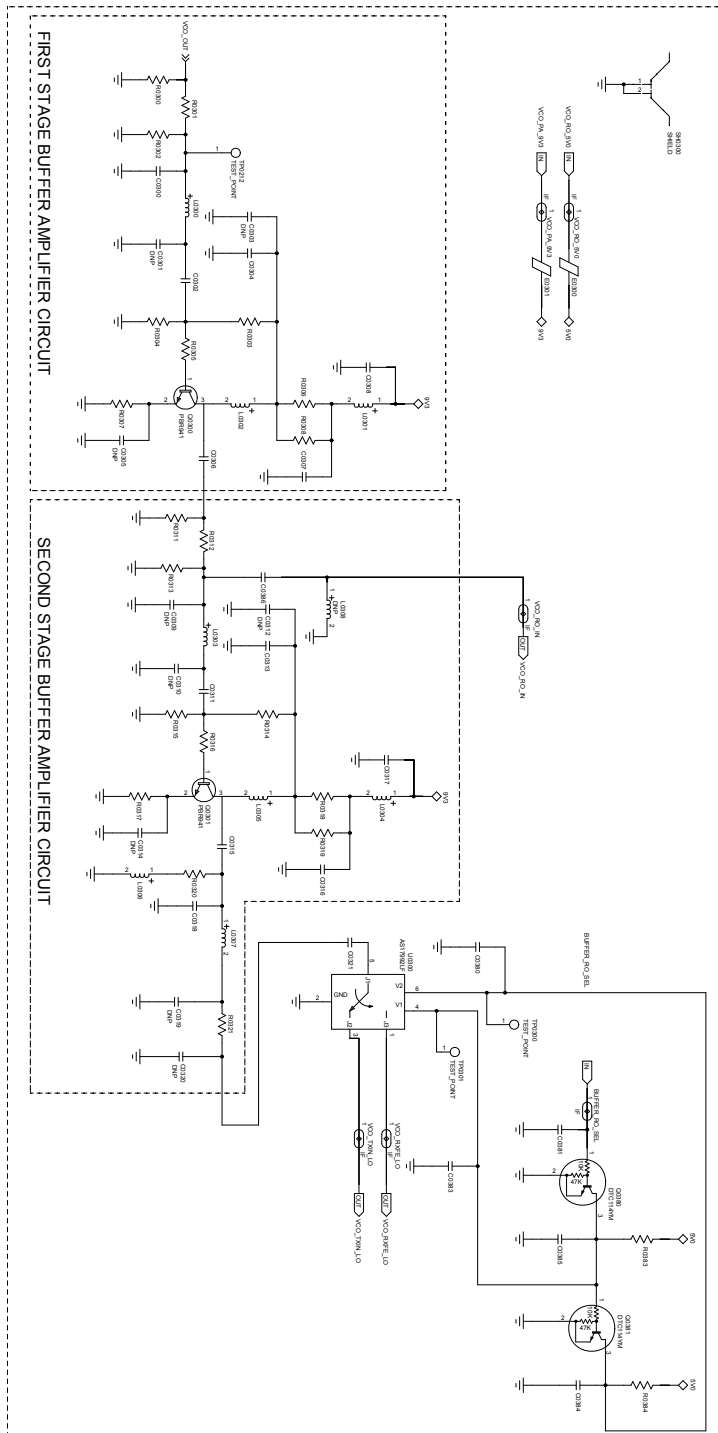

Figure 262: VCO Buffer Schematic Diagram



8.8.1.2

Parts List for 84012657001-A

Table 27: 800/900 MHz Radio Parts List

Circuit Ref.	Motorola Solutions Part No.	Circuit Ref.	Motorola Solutions Part No.
C0000M2	21667009311	L0203M7	24009343013
C0001M2	21667009170	L0204M7	24667001031
C0002M2	NOT PLACED	L0205M7	24667001031
C0003M2	NOT PLACED	L0206M7	24667001031
C0004M2	21012044001	L0207M7	24667001031
C0005M2	21012044001	L0208M7	24667001031
C0006M2	2113945C31	L0209M7	24667001031
C0007M2	21012044001	L0210M7	24009343008
C0008M2	21667009311	L0211M7	2415385H01
C0009M2	21667009166	L0212M7	24667001031
C0010M2	21667009166	L0214M7	24009343008
C0011M2	2113945C31	L0216M7	2415385H01
C0012M2	21012044001	L0218M7	24667001031
C0013M2	2113945Y02	L0220M7	24667001031
C0014M2	2113945Y02	L0222M7	24667001031
C0015M2	2113946J03	L0224M7	24667001030
C0016M2	2113945A10	L0226M7	24667001018
C0017M2	2113945Y02	L0300M7	24667001017
C0018M2	2113945A10	L0301M7	24667001031
C0019M2	2113945Y02	L0302M7	24667001031
C0020M2	2113945A10	L0303M7	24667001021
C0021M2	2113945Y02	L0304M7	24667001017
C0022M2	2113945Y02	L0305M7	24667001013
C0023M2	2113945Y02	L0401M4	24012021001
C0024M2	21012129001	L0402M4	24009344102
C0025M2	21667009166	L0403M4	24667001030
C0026M2	2113944A52	L0404M4	24009344109
C0027M2	2113945Y02	L0405M4	24009315036
C0028M2	2113945Y02	L0406M4	24012021001
C0029M2	2113945A10	L0407M4	24012021001
C0030M2	2113945A10	L0408M4	24667001030
C0031M2	2113945Y02	L0409M4	24667001030

Circuit Ref.	Motorola Solutions Part No.	Circuit Ref.	Motorola Solutions Part No.
C0032M2	21667009166	L0410M4	24667001025
C0034M2	21012044001	L0411M4	24012021001
C0035M2	21667009166	L0412M4	24667001030
C0036M2	21012025001	L0413M4	24667001030
C0037M2	21667009166	L0414M4	24009344105
C0038M2	21012044001	L0415M4	24009344106
C0039M2	2113945Y02	L0416M4	24667001014
C0040M2	2113945A10	L0417M4	24009344109
C0041M2	21667009364	L0418M4	NOT PLACED
C0042M2	21667009166	L0419M4	NOT PLACED
C0043M2	21012044001	L0421M4	24009344105
C0044M2	2113955D45	L0422M4	NOT PLACED
C0045M2	2113945Y02	L0424M4	24009344105
C0046M2	21667009166	L0428M4	24009344105
C0047M2	21667009166	L0434M4	24667001021
C0048M2	21667009166	L0435M7	NOT PLACED
C0049M2	2113945B02	L0500M3	24009344127
C0050M2	21667009166	L0501M3	24009344128
C0051M2	21667009166	L0502M3	24009344126
C0052M2	21667009166	L0503M3	24667001021
C0053M2	21667009166	L0504M3	24667001026
C0054M2	21667009166	L0505M3	24667001026
C0055M2	2113955D37	L0507M3	24667001024
C0056M2	2113945Y02	L0700M6	NOT PLACED
C0057M2	2113945B02	L0701M6	24667001014
C0058M2	NOT PLACED	L0702M6	24667001028
C0059M2	21667009166	L0703M6	24667001028
C0060M2	2113945A69	L0704M6	24667001028
C0061M2	2113945Y02	L0705M6	24667001007
C0062M2	NOT PLACED	L0707M6	24667001028
C0063M2	NOT PLACED	L0708M6	2479990G01
C0064M2	2113945A69	L0709M6	NOT PLACED
C0065M2	2113945Y02	L0710M6	2485873L01
C0066M2	2113945B02	L0711M6	NOT PLACED
C0067M2	2113945Y02	L0720M6	24667001013

Circuit Ref.	Motorola Solutions Part No.	Circuit Ref.	Motorola Solutions Part No.
C0068M2	2113955D37	L0729M6	2414032B60
C0069M2	NOT PLACED	L0730M6	24667001013
C0070M2	2113955D37	L0850M6	2460592A01
C0071M2	2113955D37	L0851M6	2460592A01
C0072M2	21667009166	L0852M6	2460592A01
C0073M2	21667009166	L0875M6	2460592A01
C0074M2	21667009166	L0876M6	24667001029
C0075M2	2113946S35	L0877M6	2414032B49
C0076M2	2113946S35	L0878M6	24667001027
C0077M2	21667009166	L0880M6	2414032B49
C0078M2	21667009372	L0882M6	24667001027
C0079M2	2113955D37	L0885M6	24667001014
C0080M2	2113945B02	L0900M6	24667000031
C0081M2	2113945B02	L0901M6	24009344018
C0082M2	2113945B02	L0902M6	24667000031
C0083M2	2113945B02	L0950M6	NOT PLACED
C0084M2	21667009166	L0951M6	24009344003
C0085M2	21667009166	L0952M6	24009344005
C0086M2	2113945C31	L3100M1	24012091002
C0087M2	2113946S35	M0700M6	2686201B02
C0088M2	2113945Y02	P0000M2	NOT PLACED
C0089M2	2113945Y02	P1000M1	2887818K02
C0090M2	2113945B02	P3000M6	09009344001
C0091M2	2113944C82	PASTE1	BU000032A01
C0092M2	21667009166	PASTE2	BU000032A01
C0093M2	2113945Y02	PASTE3	BU000032A01
C0094M2	2113945Y02	PASTE4	BU000032A01
C0095M2	2113945A13	PASTE5	BU000032A01
C0096M2	2113945B02	PASTE6	BU000032A01
C0097M2	2113945B02	PCB	84012728001
C0098M2	21667009166	Q0000M2	4813973A13
C0099M2	2113945Y02	Q0001M2	48009494001
C0100M2	2113945Y02	Q0002M2	4813970A59
C0101M2	21667009166	Q0003M2	4885061Y01
C0102M2	21667009166	Q0004M2	4815272H01

Circuit Ref.	Motorola Solutions Part No.	Circuit Ref.	Motorola Solutions Part No.
C0103M2	21667009166	Q0006M2	4813973A04
C0104M2	21667009166	Q0200M7	4885061Y01
C0105M2	21667009166	Q0201M7	4885061Y01
C0106M2	2113945B02	Q0202M7	4815272H01
C0107M2	2113945B02	Q0203M7	4815272H01
C0108M2	21667009166	Q0204M7	4885061Y01
C0109M2	2113945Y02	Q0205M7	48009494001
C0110M2	21667009381	Q0206M7	4815272H01
C0111M2	2113945Y02	Q0207M7	48009494001
C0112M2	21667009166	Q0300M7	4802197J95
C0113M2	21667009166	Q0400M4	4815271H01
C0114M2	2113945Y02	Q0401M4	4815267H01
C0115M2	21667009370	Q0402M4	4815118H01
C0116M2	NOT PLACED	Q0403M4	4815270H01
C0117M2	21667009374	Q0404M4	4815271H01
C0118M2	21667009375	Q0405M4	4815118H01
C0119M2	2113945A10	Q0700M6	4816547H01
C0120M2	21667009166	Q0701M6	4816013H01
C0121M2	NOT PLACED	Q0703M6	4802246J29
C0122M2	21667009166	Q0704M6	4816548H01
C0123M2	21667009381	Q0705M6	48012022001
C0124M2	21667009166	Q0875M6	4813970A62
C0132M2	2113946J03	Q0876M6	4816134H01
C0134M2	21667009166	Q0900M6	4815272H01
C0135M2	21667009166	Q0901M6	4815271H01
C0136M2	21667009166	Q1000M1	4815263H01
C0137M2	2113945Y02	Q1001M1	4815272H01
C0138M2	21667009166	Q1002M1	4815261H01
C0139M2	21667009166	Q1004M1	4815261H01
C0140M2	2113945Y02	Q1005M1	4815261H01
C0141M2	2113945Y02	Q3000M6	0105959T72
C0143M2	2113945Y02	Q3001M6	0105959T72
C0144M2	2113945Y02	Q3002M6	4813973B01
C0145M2	21667009166	Q3100M1	4815272H01
C0146M2	2113945A10	Q3101M1	4809939C47

Circuit Ref.	Motorola Solutions Part No.	Circuit Ref.	Motorola Solutions Part No.
C0147M2	2113945A10	Q3102M1	4809939C47
C0149M2	21667009166	Q3103M1	48009494001
C0150M2	21667009166	Q3105M1	4809939C47
C0151M2	21667009368	Q3160M1	48009494001
C0200M7	21667009166	Q3161M1	4815272H01
C0201M7	NOT PLACED	Q3162M1	4813973M07
C0202M7	21667009166	Q3163M1	48009494001
C0203M7	NOT PLACED	Q3200M1	4815270H01
C0204M7	NOT PLACED	Q3201M1	4815272H01
C0205M7	21667009274	Q3202M1	4815270H01
C0206M7	21667009320	Q3203M1	4815270H01
C0207M7	21667009320	Q3204M1	4815270H01
C0208M7	21667009303	Q3205M1	4815270H01
C0209M7	21667009297	Q3206M1	4815270H01
C0210M7	NOT PLACED	Q3207M1	4815270H01
C0211M7	NOT PLACED	Q3208M1	4815263H01
C0212M7	21667009286	Q4000M1	4809939C47
C0213M7	21667009274	Q4001M1	4809939C47
C0214M7	21667009303	Q4002M1	4809939C47
C0215M7	21667009332	Q4100M1	4816023H01
C0216M7	21667009303	Q4101M1	4815261H01
C0217M7	21667009332	Q4102M1	4815263H01
C0218M7	21667009320	Q4103M1	48012271001
C0221M7	21667009371	Q4105M1	48012271001
C0222M7	21667009366	Q4106M1	48012271001
C0223M7	21667009372	Q4109M1	48012271001
C0224M7	21667009366	Q4112M1	48012271001
C0225M7	2113945Y02	Q4120M1	4809939C47
C0226M7	21667009311	R0000M2	0613952R66
C0227M7	2113945Y02	R0001M2	0613952R66
C0228M7	21667009166	R0002M2	0613952Q96
C0229M7	21667009166	R0003M2	0613952Q57
C0230M7	21667009166	R0004M2	0613952Q34
C0231M7	21667009166	R0005M2	0613952R66
C0232M7	21667009166	R0006M2	0613952Q25

Circuit Ref.	Motorola Solutions Part No.	Circuit Ref.	Motorola Solutions Part No.
C0233M7	21667009284	R0007M2	0613952Q54
C0234M7	21667009284	R0008M2	0613952R01
C0235M7	21667009166	R0009M2	0613952Q58
C0236M7	2113945Y02	R0010M2	0613952R66
C0237M7	21667009166	R0011M2	0613952Q36
C0238M7	2113945Y02	R0012M2	0613952Q86
C0239M7	2113945Y02	R0013M2	0613952Q35
C0240M7	21667009166	R0014M2	0613952R66
C0241M7	21667009166	R0015M2	0613952R66
C0242M7	21667009166	R0018M2	0613952Q80
C0243M7	21667009166	R0019M2	0613952R01
C0244M7	21667009297	R0020M2	0613952R12
C0245M7	21667009291	R0021M2	0613952Q80
C0246M7	21667009166	R0022M2	0613952R66
C0247M7	21667009166	R0023M2	0613952Q83
C0248M7	21667009364	R0024M2	0613952Q80
C0249M7	21667009166	R0025M2	0613952R66
C0252M7	21667009320	R0026M2	0613952R66
C0256M7	21667009374	R0027M2	0613952R12
C0257M7	21667009370	R0028M2	0613952R66
C0259M7	2113945Y02	R0029M2	0613952Q25
C0263M7	21667009166	R0030M2	0613952R66
C0265M7	21667009166	R0031M2	0613952R66
C0267M7	21667009284	R0033M2	0613952R01
C0269M7	21667009166	R0034M2	0613952Q57
C0270M7	2113945Y02	R0040M2	0613952Q70
C0271M7	21667009166	R0041M2	0613952Q58
C0272M7	2113945Y02	R0042M2	0613952Q42
C0276M7	21667009332	R0043M2	0613952Q73
C0277M7	NOT PLACED	R0044M2	0613952R25
C0278M7	NOT PLACED	R0045M2	0613952R66
C0300M7	21667009303	R0046M2	0613952Q57
C0301M7	NOT PLACED	R0051M2	0613952R01
C0302M7	21667009303	R0052M2	0613952R01
C0304M7	21667009390	R0054M2	0613952M25

Circuit Ref.	Motorola Solutions Part No.	Circuit Ref.	Motorola Solutions Part No.
C0305M7	2113945Y02	R0056M2	0613952R66
C0306M7	2113945B02	R0058M2	0613952Q74
C0307M7	21667009390	R0059M2	0613952R66
C0308M7	2113945B02	R0060M2	0613952Q86
C0309M7	21667009297	R0061M2	0613952Q85
C0310M7	21667009282	R0062M2	0613952Q61
C0311M7	21667009364	R0063M2	0613952Q64
C0400M4	21667009005	R0064M7	NOT PLACED
C0402M4	21667009166	R0200M7	0613952R66
C0403M4	21667009274	R0201M7	0613952R27
C0404M4	21667009332	R0202M7	NOT PLACED
C0405M4	21667009005	R0203M7	0613952R07
C0406M4	21667009274	R0204M7	0613952R05
C0407M4	21667009332	R0205M7	NOT PLACED
C0408M4	2113945C31	R0206M7	NOT PLACED
C0409M4	2113945C31	R0207M7	0613952Q84
C0410M4	21667009166	R0208M7	0613952Q86
C0411M4	21667009166	R0209M7	0613952Q85
C0412M4	2113946F05	R0210M7	0613952Q85
C0413M4	21667009166	R0211M7	21667009380
C0414M4	21667009166	R0212M7	0613952Q32
C0415M4	21667009368	R0213M7	0613952Q67
C0416M4	2113945C31	R0214M7	0613952Q67
C0417M4	21667009166	R0215M7	0613952Q67
C0418M4	21667009164	R0216M7	0613952Q67
C0419M4	21667009274	R0217M7	0613952Q49
C0420M4	21667009166	R0218M7	0613952Q49
C0421M4	21667009274	R0219M7	0613952R66
C0422M4	21667009320	R0220M7	0613952R66
C0423M4	21667009368	R0221M7	0613952R66
C0424M4	21667009274	R0222M7	0613952Q84
C0425M4	21667009320	R0223M7	0613952Q73
C0426M4	2113946F05	R0224M7	0613952Q85
C0427M4	21667009372	R0225M7	0613952Q73
C0428M4	21667009005	R0226M7	0613952Q29

Circuit Ref.	Motorola Solutions Part No.	Circuit Ref.	Motorola Solutions Part No.
C0429M4	21667009274	R0227M7	0613952G67
C0430M4	21667009161	R0228M7	0613952Q67
C0431M4	21667009370	R0230M7	0613952Q67
C0433M4	21667009166	R0232M7	0613952Q49
C0434M4	21667009384	R0233M7	0613952R66
C0435M4	21667009378	R0234M7	NOT PLACED
C0436M4	21667009166	R0235M7	0613952Q18
C0437M4	2113945C31	R0250M7	21667009380
C0438M4	21667009166	R0300M7	0613952Q66
C0439M4	21667009339	R0301M7	0613952Q25
C0440M4	21667009297	R0302M7	0613952Q66
C0441M4	21667009339	R0303M7	0613952R05
C0442M4	21667009286	R0304M7	0613952Q89
C0443M4	21667009346	R0305M7	0613952Q33
C0444M4	21667009274	R0306M7	0613952Q32
C0445M4	21667009392	R0307M7	0613952Q49
C0446M4	21667009346	R0308M7	0613952Q32
C0447M4	21667009282	R0309M7	0613952Q42
C0448M4	21667009339	R0400M4	0613952R01
C0449M4	21667009315	R0401M4	0613952H73
C0450M4	21667009388	R0402M4	0613952R25
C0451M4	21667009166	R0403M4	0613952R01
C0452M4	21667009339	R0404M4	0613952R25
C0453M4	21667009339	R0405M4	0613952R05
C0454M4	21667009346	R0406M4	0613952Q91
C0455M4	21667009346	R0407M4	0613952Q91
C0456M4	21667009366	R0408M4	0613952Q75
C0457M4	21667009291	R0409M4	0613952Q69
C0458M4	2113946F05	R0410M4	0613952R01
C0459M4	21667009355	R0411M4	0613952R01
C0460M4	21667009384	R0412M4	0613952Q83
C0461M4	NOT PLACED	R0413M4	0613958H55
C0462M4	21667009159	R0414M4	0613958H55
C0463M4	NOT PLACED	R0415M4	0613952Q57
C0464M4	21667009158	R0416M4	0613952Q69

Circuit Ref.	Motorola Solutions Part No.	Circuit Ref.	Motorola Solutions Part No.
C0465M4	21667009166	R0417M4	0613952Q69
C0468M4	21667009166	R0418M4	0613952Q69
C0469M4	21667009166	R0419M4	0613952Q69
C0470M4	21667009380	R0420M4	0613952R25
C0471M4	NOT PLACED	R0421M4	0613952R25
C0472M4	NOT PLACED	R0422M4	NOT PLACED
C0473M4	NOT PLACED	R0423M4	0613952R25
C0499M4	NOT PLACED	R0424M4	0613952R66
C0500M3	21667009369	R0425M4	NOT PLACED
C0501M3	21667009332	R0426M4	0613952Q87
C0502M3	2113944M21	R0427M4	0613952Q93
C0503M3	2113945C31	R0429M4	0613952R66
C0504M3	2113945C31	R0430M4	NOT PLACED
C0505M3	21667011351	R0431M4	0613952R01
C0506M3	NOT PLACED	R0432M4	0613952H73
C0507M3	21667009374	R0433M4	0613952R01
C0508M3	21667009366	R0434M4	0613952L46
C0509M3	21667009382	R0435M4	0613952L46
C0510M3	21667009366	R0436M4	0613952R66
C0511M3	21667009355	R0437M4	0613952Q77
C0512M3	21667009303	R0438M4	0613958H22
C0513M3	21667009368	R0439M4	0613952Q83
C0515M3	21667009383	R0440M4	0613958H25
C0516M3	21667011464	R0441M4	0613958H49
C0517M3	21667009315	R0442M4	0613952Q83
C0518M3	21667009339	R0443M4	0613952Q25
C0700M6	2113944C45	R0444M4	0613952K25
C0701M6	2113944A41	R0445M4	0613952Q75
C0702M6	2113944C38	R0446M4	NOT PLACED
C0703M6	21667009163	R0447M4	0613952R66
C0704M6	2113944A41	R0448M4	0613952Q12
C0705M6	2113944A41	R0500M3	0613952Q87
C0706M6	NOT PLACED	R0501M3	0613952R19
C0707M6	2113944C82	R0502M3	0613952Q66
C0708M6	2113944C30	R0503M3	0613952Q88

Circuit Ref.	Motorola Solutions Part No.	Circuit Ref.	Motorola Solutions Part No.
C0709M6	2113945C04	R0504M3	0613952Q61
C0710M6	2113944A41	R0505M3	0613952R66
C0711M6	2113944C47	R0525M3	0613952R66
C0712M6	2113945C04	R0700M6	0613952H90
C0713M6	2113944A41	R0701M6	0613952G67
C0714M6	21012094097	R0702M6	0613952H89
C0715M6	2113944A41	R0703M6	0613952J01
C0716M6	2113944C55	R0704M6	0613952J10
C0717M6	2113944C39	R0705M6	0613952Q46
C0718M6	NOT PLACED	R0706M6	0613952Q58
C0719M6	2113944A41	R0707M6	0613952Q46
C0720M6	2113944A37	R0708M6	0613952H44
C0721M6	2113944C82	R0709M6	NOT PLACED
C0722M6	NOT PLACED	R0711M6	0613958S44
C0723M6	2113945C04	R0712M6	0613958S44
C0724M6	2113944C34	R0713M6	NOT PLACED
C0725M6	NOT PLACED	R0714M6	0613952H09
C0726M6	2113944C51	R0715M6	0613952H09
C0727M6	NOT PLACED	R0716M6	0613952H09
C0728M6	NOT PLACED	R0717M6	0613952H09
C0729M6	NOT PLACED	R0718M6	0613952J05
C0730M6	NOT PLACED	R0719M6	0613952H89
C0731M6	2113944A41	R0720M6	0613952H95
C0732M6	2113945A09	R0721M6	0613952G67
C0733M6	NOT PLACED	R0722M6	0613952H32
C0734M6	2113945A09	R0723M6	0613952G67
C0735M6	21012094093	R0724M6	NOT PLACED
C0736M6	NOT PLACED	R0725M6	0613958S29
C0737M6	2113944C51	R0726M6	NOT PLACED
C0738M6	2113944A41	R0727M6	0613958S29
C0739M6	2113945C31	R0728M6	NOT PLACED
C0740M6	2113944C51	R0729M6	NOT PLACED
C0741M6	2113944C82	R0730M6	NOT PLACED
C0742M6	2113945L49	R0731M6	0613958S29
C0743M6	2113944C35	R0732M6	NOT PLACED

Circuit Ref.	Motorola Solutions Part No.	Circuit Ref.	Motorola Solutions Part No.
C0744M6	2113944C34	R0733M6	NOT PLACED
C0745M6	2113946J04	R0734M6	0613958S29
C0746M6	NOT PLACED	R0736M6	0613959Q25
C0747M6	2113944C45	R0737M6	0613952F01
C0748M6	NOT PLACED	R0738M6	0613959Q53
C0749M6	2113944C83	R0739M6	0613952H73
C0750M6	NOT PLACED	R0740M6	NOT PLACED
C0751M6	NOT PLACED	R0741M6	0613952E66
C0752M6	2113944C85	R0742M6	NOT PLACED
C0753M6	2113944C51	R0743M6	0613952E66
C0754M6	2113944C45	R0744M6	0613959Q53
C0755M6	2113944C85	R0745M6	NOT PLACED
C0756M6	NOT PLACED	R0746M6	0613952F01
C0757M6	NOT PLACED	R0759M6	0613959H12
C0758M6	21667003042	R0849M6	0613952G67
C0759M6	21667003042	R0876M6	0613958S73
C0760M6	2113944C45	R0877M6	0613959Y37
C0761M6	2113944C45	R0878M6	0613959Y37
C0762M6	21012094096	R0879M6	0613952J25
C0763M6	21012094096	R0883M6	0613952G67
C0764M6	2113944C51	R0902M6	0613952R66
C0765M6	21667003033	R0903M6	0613952N01
C0766M6	21667003033	R0904M6	0613952R66
C0767M6	NOT PLACED	R0905M6	0613952H42
C0768M6	NOT PLACED	R0906M6	0613958H46
C0769M6	NOT PLACED	R0907M6	0613958H55
C0770M6	21667003029	R0908M6	0613952H42
C0771M6	NOT PLACED	R0909M6	NOT PLACED
C0772M6	2113944C35	R0910M6	0613952H91
C0773M6	NOT PLACED	R0911M6	0613952H85
C0774M6	NOT PLACED	R0912M6	0613958H46
C0775M6	NOT PLACED	R0913M6	0613952M51
C0776M6	21667003038	R0914M6	0613952M71
C0777M6	21012094097	R0915M6	0613952R66
C0778M6	21012094097	R0916M6	0613952R66

Circuit Ref.	Motorola Solutions Part No.	Circuit Ref.	Motorola Solutions Part No.
C0779M6	NOT PLACED	R0917M6	0613952P01
C0780M6	21012094093	R0919M6	0613952P01
C0781M6	NOT PLACED	R0920M6	0613952N01
C0782M6	NOT PLACED	R0921M6	0613952N01
C0783M6	21667003038	R0922M6	0613952R66
C0784M6	NOT PLACED	R0923M6	0613952M30
C0785M6	21012094093	R0924M6	0613952N01
C0786M6	NOT PLACED	R0925M6	0613952Q59
C0787M6	21012094048	R0926M6	0613952H79
C0788M6	21012094048	R0927M6	0613952N01
C0789M6	2113944C36	R0928M6	0613952P18
C0790M6	2113944C82	R0929M6	0613952N85
C0791M6	21667011042	R0930M6	0613952N37
C0792M6	21012094089	R0931M6	0613952M77
C0793M6	2113944C32	R0932M6	0613952N43
C0794M6	2113944C82	R0933M6	0613952M37
C0795M6	21667011042	R0934M6	0613952J17
C0796M6	2113944C39	R0935M6	0613952H91
C0797M6	2113944C39	R0936M6	0613952H91
C0798M6	2113944C38	R0937M6	NOT PLACED
C0799M6	2113944C38	R0938M6	NOT PLACED
C0800M6	2113944C32	R0939M6	NOT PLACED
C0801M6	2113944C38	R0940M6	0613952Z72
C0802M6	2113944C38	R0941M6	0613952N58
C0803M6	2113944C38	R0942M6	0613952N58
C0804M6	2113944C38	R0943M6	0613952N58
C0805M6	2113944C32	R0950M6	0613952G67
C0806M6	21012094089	R0951M6	0613958M21
C0807M6	21012094092	R0952M6	0613958M21
C0808M6	21012094097	R0953M6	0613952G67
C0809M6	21012094092	R0954M6	0613952H58
C0810M6	21012094048	R0955M6	0613952H58
C0811M6	21012094048	R0956M6	0613952H67
C0812M6	2113944C38	R0957M6	0613958C18
C0813M6	2113944C38	R0958M6	0613958C18

Circuit Ref.	Motorola Solutions Part No.	Circuit Ref.	Motorola Solutions Part No.
C0814M6	2113944C38	R0959M6	0613952R66
C0815M6	2113944C38	R0960M6	0613952N58
C0816M6	21012094097	R0961M6	0613952N58
C0817M6	21667003033	R0962M6	0613952N58
C0818M6	NOT PLACED	R0965M6	NOT PLACED
C0819M6	21667003033	R0966M6	NOT PLACED
C0820M6	21012094092	R0980M6	0613952N43
C0821M6	NOT PLACED	R0981M6	0613952P01
C0822M6	NOT PLACED	R1000M1	0613952R66
C0823M6	NOT PLACED	R1001M1	0613952M66
C0824M6	21012094089	R1002M1	0613952R66
C0825M6	21012094097	R1003M1	0613952R66
C0826M6	21667011491	R1004M1	0613952R66
C0827M6	21667011491	R1005M1	0613952M66
C0828M6	2113944C35	R1007M1	0613952R66
C0829M6	2113944C82	R1008M1	0613952R66
C0830M6	2113944C84	R1009M1	0613952R66
C0831M6	2113944C34	R1010M1	NOT PLACED
C0832M6	2113944C32	R1011M1	NOT PLACED
C0833M6	2113944C82	R1012M1	0613952R66
C0834M6	2113944C33	R1013M1	0613952M66
C0835M6	21012094048	R1014M1	NOT PLACED
C0836M6	2113944C90	R1016M1	NOT PLACED
C0837M6	NOT PLACED	R1018M1	NOT PLACED
C0838M6	21012094085	R1019M1	0613952R66
C0839M6	21667011146	R1020M1	0613952M66
C0840M6	21012094085	R1021M1	0613952Q73
C0841M6	2113944C37	R1022M1	NOT PLACED
C0842M6	NOT PLACED	R1023M1	0613952R66
C0843M6	2113944C37	R1024M1	NOT PLACED
C0844M6	NOT PLACED	R1025M1	0613952Q73
C0845M6	21667009291	R1026M1	0613952R66
C0846M6	21667009320	R1027M1	NOT PLACED
C0847M6	21667009320	R1028M1	0613952R66
C0848M6	2113944C45	R1029M1	0613952R66

Circuit Ref.	Motorola Solutions Part No.	Circuit Ref.	Motorola Solutions Part No.
C0849M6	2113944C08	R1030M1	NOT PLACED
C0850M6	21012094085	R1031M1	0613952R66
C0851M6	21012094089	R1033M1	0613952Q73
C0852M6	21012094086	R1034M1	0613952R17
C0853M6	21012094092	R1035M1	NOT PLACED
C0854M6	21012094090	R1036M1	0613952M66
C0855M6	21012094090	R1037M1	0613952M66
C0856M6	21012094048	R1038M1	0613952R66
C0857M6	21012094089	R1039M1	0613952R66
C0858M6	NOT PLACED	R1040M1	0613952M66
C0859M6	21012094086	R1041M1	0613952R66
C0860M6	21012094086	R1042M1	0613952M66
C0861M6	21012094092	R1043M1	0613952R66
C0862M6	21012094092	R1044M1	0613952M66
C0863M6	21012094092	R1045M1	0613952M66
C0864M6	21012094092	R1046M1	0613952M66
C0865M6	NOT PLACED	R1047M1	0613952R66
C0866M6	21012094090	R1048M1	0613952R66
C0867M6	21012094090	R1049M1	0613952Q73
C0868M6	21012094082	R1050M1	0613952Q73
C0869M6	21012094090	R1051M1	0613952K68
C0870M6	21012094048	R1052M1	NOT PLACED
C0871M6	2113944C85	R1053M1	0613952R66
C0872M6	2113944C85	R1054M1	0613952M66
C0873M6	21667003028	R1056M1	0613952Q73
C0874M6	NOT PLACED	R1057M1	0613952Q73
C0875M6	2113944C46	R1058M1	0613952M66
C0876M6	NOT PLACED	R1059M1	0613952R66
C0877M6	2113944C42	R1060M1	0613952R66
C0878M6	NOT PLACED	R1061M1	0613952R66
C0879M6	2113944C42	R1062M1	NOT PLACED
C0880M6	21667003028	R1063M1	NOT PLACED
C0881M6	21012094048	R1064M1	NOT PLACED
C0882M6	21667011146	R1065M1	0613952R66
C0883M6	21667011491	R1066M1	0613952M66

Circuit Ref.	Motorola Solutions Part No.	Circuit Ref.	Motorola Solutions Part No.
C0884M6	2113944C90	R1067M1	0613952M66
C0885M6	2113944C51	R1068M1	0613952R32
C0886M6	2113944C47	R1069M1	NOT PLACED
C0887M6	21012094082	R1070M1	0613952Q77
C0888M6	21012094102	R1071M1	0613952Q77
C0889M6	NOT PLACED	R1072M1	0613952Q49
C0890M6	NOT PLACED	R1073M1	0613952R01
C0891M6	21667003028	R1074M1	0613952R66
C0892M6	NOT PLACED	R1075M1	0613952R66
C0900M6	NOT PLACED	R1076M1	0613952R66
C0901M6	NOT PLACED	R1077M1	0613952R66
C0902M6	2113944C51	R1078M1	0613952R66
C0905M6	2113945C31	R1079M1	0613952R66
C0906M6	2113945A10	R1080M1	0613952Q32
C0907M6	2113945L41	R1081M1	0613952Q32
C0908M6	21667009166	R1082M1	0613952Q32
C0909M6	2113944C02	R1084M1	0613952R66
C0910M6	21667009166	R1088M1	NOT PLACED
C0911M6	2113944C02	R1089M1	0613952R05
C0912M6	21667009166	R1090M1	0613952R05
C0913M6	21667009166	R1091M1	NOT PLACED
C0916M6	NOT PLACED	R1092M1	0613952M43
C0917M6	21667009166	R1093M1	0613952Q73
C0918M6	21667009166	R1094M1	0613952M66
C0919M6	21667009166	R1095M1	0613952Q34
C0920M6	2113944C02	R1096M1	0613952Q34
C0921M6	2113944C02	R1097M1	0613952R66
C0922M6	2113945C31	R1098M1	0613952R66
C0923M6	2113944C02	R2000M1	0613952M66
C0924M6	21667009166	R2002M1	0613952M66
C0925M6	2113945C31	R2003M1	0613952M30
C0926M6	2113944C02	R3000M6	0613952H60
C0927M6	2113944C01	R3001M6	0615871H01
C0928M6	2113944C51	R3002M6	0615871H01
C0929M6	2113944C49	R3003M6	0615871H01

Circuit Ref.	Motorola Solutions Part No.	Circuit Ref.	Motorola Solutions Part No.
C0930M6	NOT PLACED	R3004M6	0615871H01
C0931M6	2113944C02	R3005M6	0613952H25
C0950M6	2113944C47	R3006M6	0613952H25
C0951M6	21667011356	R3007M6	0613952M30
C0952M6	2113944C47	R3008M6	0613952G67
C0953M6	2113944C47	R3009M6	0613952M43
C0954M6	21667011351	R3010M6	0613952G67
C0955M6	2113944C47	R3011M6	0613959Q60
C0956M6	2113944C01	R3012M6	0613959Q60
C0957M6	2113944C49	R3013M6	0613952R01
C1000M1	2113945Y02	R3014M6	0613952R01
C1001M1	2113945Y02	R3015M6	0615871H01
C1002M1	2113946K03	R3018M6	0613952H73
C1003M1	2113945Y02	R3019M6	0613952H60
C1004M1	2113945Y02	R3020M6	0613952G67
C1005M1	2113945Y02	R3021M6	0613952R25
C1006M1	2113945Y02	R3022M6	0613952R66
C1007M1	2113945Y02	R3023M6	NOT PLACED
C1008M1	2113946D05	R3101M1	0613952Z66
C1009M1	2113945Y02	R3102M1	0613952M66
C1010M1	2113945Y02	R3103M1	0613952N62
C1011M1	2113945B02	R3104M1	0613952M30
C1012M1	2113945Y02	R3105M1	0613952R01
C1013M1	2113945Y02	R3106M1	0613952M09
C1014M1	2113945Y02	R3107M1	0613952M85
C1015M1	2113945B02	R3108M1	0613952R17
C1016M1	21667009166	R3109M1	0613952R17
C1017M1	21667009162	R3110M1	0613952N55
C1018M1	21667009162	R3111M1	0613952R32
C1019M1	21667009162	R3112M1	0613952P12
C1020M1	21667009162	R3113M1	0613952R17
C1021M1	2113945Y02	R3114M1	0613952N01
C1022M1	2113945Y02	R3115M1	0613952Z63
C1023M1	2113945Y02	R3116M1	0613952E83
C1024M1	2113945Y02	R3117M1	0613952Q73

Circuit Ref.	Motorola Solutions Part No.	Circuit Ref.	Motorola Solutions Part No.
C1025M1	2113945Y02	R3118M1	0613952R10
C1026M1	2113945Y02	R3119M1	0613952Q73
C1027M1	NOT PLACED	R3120M1	0613952R66
C1028M1	2113945Y02	R3121M1	0613952R66
C1029M1	2113956B54	R3122M1	0613952M43
C1032M1	2113956B54	R3123M1	0613952M54
C1035M1	2113945B02	R3124M1	0613952R66
C1036M1	2113946D05	R3125M1	0613952R66
C1040M1	2113945Y02	R3126M1	0613952R66
C1041M1	2113945B02	R3127M1	0613959Y09
C1042M1	2113945Y02	R3128M1	0613952M10
C1043M1	2113956B54	R3129M1	0613952M58
C1044M1	2113945B02	R3130M1	0613952R25
C1045M1	2113945B02	R3131M1	0613952R01
C1047M1	2113945Y02	R3132M1	0613952R01
C1048M1	2113945B02	R3133M1	0613952R29
C2000M1	2113945Y02	R3134M1	NOT PLACED
C2001M1	2113945Y02	R3135M1	0613952R66
C2002M1	2113945B02	R3136M1	0613952R17
C2003M1	21667009162	R3137M1	0613952R17
C2004M1	2113956B54	R3138M1	0613952R17
C2005M1	2113946D05	R3139M1	0613952R66
C2006M1	2113945Y02	R3140M1	0613952Q91
C2007M1	2113945Y02	R3141M1	0613959Y13
C2008M1	2113945B02	R3142M1	NOT PLACED
C2009M1	21667009162	R3143M1	0613952Q91
C2010M1	2113945Y02	R3144M1	0613952R66
C2011M1	2113945Y02	R3145M1	0613959Y09
C2012M1	2113945Y02	R3146M1	0613952M85
C2013M1	2113945Y02	R3147M1	0613952M43
C2014M1	2113945B02	R3148M1	0613952R66
C2015M1	21667009162	R3149M1	0613952R01
C2016M1	2113956B54	R3150M1	0613952N62
C2020M1	2113956B54	R3151M1	0613952R25
C2021M1	2113956D59	R3153M1	0613952R66

Circuit Ref.	Motorola Solutions Part No.	Circuit Ref.	Motorola Solutions Part No.
C2022M1	2113956D59	R3154M1	0613952Q89
C3000M6	2113944C38	R3155M1	0613952Q89
C3001M6	2113944C06	R3156M1	0613952R17
C3002M6	2113944C06	R3157M1	0613952R01
C3003M6	2113945C31	R3158M1	0613952R66
C3004M6	2113945C02	R3159M1	0613952R01
C3005M6	2113945C02	R3160M1	0613952Q89
C3008M6	2113944C51	R3161M1	0613952Q73
C3009M6	2113945C31	R3162M1	0613952Q85
C3010M6	2113944C46	R3163M1	0613952R01
C3011M6	NOT PLACED	R3164M1	0613952Q75
C3012M6	2113946J04	R3165M1	0613952R01
C3013M6	2113945C31	R3166M1	0613952R17
C3014M6	21009337414	R3167M1	0613952R01
C3015M6	2113946G01	R3168M1	0613952Q73
C3016M6	2113945C31	R3169M1	0613952R01
C3019M6	2113946S35	R3170M1	0613952R01
C3020M6	2113945C26	R3171M1	NOT PLACED
C3021M6	2113944C06	R3172M1	NOT PLACED
C3022M6	2113945A10	R3173M1	0613952R66
C3029M6	NOT PLACED	R3174M1	0613952R66
C3038M6	21667009379	R3175M1	0689774Y02
C3041M6	21667009379	R3176M1	0689774Y02
C3042M6	21667009379	R3177M1	0613952R66
C3044M6	21667009379	R3178M1	0615871H01
C3046M6	NOT PLACED	R3179M1	0613952R17
C3047M6	NOT PLACED	R3180M1	0613952R01
C3048M6	NOT PLACED	R3181M1	NOT PLACED
C3049M6	NOT PLACED	R3182M1	0613952R66
C3102M1	21009337414	R3183M1	0613952H92
C3103M1	21667009166	R3184M1	0613952M30
C3104M1	2113946F08	R3200M1	0613952C44
C3105M1	2113946J04	R3201M1	0613952Q49
C3106M1	2113945C31	R3202M1	0613952C44
C3107M1	2113944C38	R3203M1	0613952Q49

Circuit Ref.	Motorola Solutions Part No.	Circuit Ref.	Motorola Solutions Part No.
C3109M1	21667009166	R3204M1	0613952C44
C3110M1	2113944C06	R3205M1	0613952C44
C3111M1	2113946J04	R3206M1	0613952R01
C3112M1	2113945Y02	R3207M1	0613952R01
C3113M1	2113946S35	R3208M1	0613952N30
C3115M1	2113944C06	R3209M1	0613952R03
C3116M1	2113955D13	R3210M1	0613952Q67
C3117M1	2113955D13	R3211M1	0613952N30
C3118M1	2113945Y02	R3212M1	0613952R03
C3119M1	2113945Y02	R3213M1	0613952Q42
C3120M1	2113956E60	R3214M1	0613952J25
C3121M1	2113956D58	R3215M1	0613952R01
C3122M1	2113956A51	R3216M1	0613952R17
C3123M1	2113956A51	R3217M1	0613952R01
C3124M1	2113946D07	R3218M1	0613952R01
C3125M1	2113946D05	R3219M1	NOT PLACED
C3126M1	2113944C06	R3220M1	0613952R01
C3127M1	2113946S35	R3221M1	NOT PLACED
C3128M1	2113946D05	R3222M1	0613952R01
C3129M1	2113945Y02	R3223M1	0613952R66
C3130M1	2113946D05	R3224M1	NOT PLACED
C3131M1	2113946A02	R3225M1	NOT PLACED
C3132M1	2113946D05	R3226M1	0613952R01
C3133M1	2113946D05	R3229M1	0613952R01
C3134M1	2113946S35	R3230M1	0613952R10
C3135M1	2113956A51	R3231M1	0613952R10
C3136M1	21012095001	R3232M1	0613952R10
C3137M1	2113946D05	R3233M1	0613952R01
C3139M1	2113956A51	R3234M1	NOT PLACED
C3140M1	21012095001	R3235M1	0613952R01
C3141M1	2113945Y02	R3236M1	0613952R10
C3142M1	21012102001	R3237M1	NOT PLACED
C3143M1	21667009366	R3238M1	0613952R01
C3144M1	2113945Y02	R3239M1	0613952Q49
C3145M1	2113944C06	R3240M1	0613952R01

Circuit Ref.	Motorola Solutions Part No.	Circuit Ref.	Motorola Solutions Part No.
C3146M1	21012102001	R3241M1	0613952M54
C3149M1	2113956A51	R3242M1	0613952R01
C3150M1	2113956C37	R3243M1	0613952R01
C3151M1	2113945B02	R3244M1	0613952R10
C3152M1	2113944C06	R3245M1	NOT PLACED
C3153M1	2113946J04	R3246M1	0613952R01
C3154M1	2113955D13	R3247M1	0613952Q49
C3155M1	2113945Y02	R3248M1	0613952R66
C3156M1	2113945Y02	R3249M1	0613952R66
C3157M1	2113945Y02	R3250M1	0613952R66
C3160M1	2113945Y02	R3251M1	0613952R66
C3161M1	NOT PLACED	R3252M1	0613952R66
C3171M1	2113946D07	R3253M1	0613952R66
C3173M1	2113946D07	R3254M1	0613952R01
C3175M1	2113946A01	R3255M1	0613952R66
C3176M1	2113944C48	R3256M1	0613952M66
C3177M1	2113946F08	R3257M1	0613952R01
C3200M1	21667009166	R3258M1	0613952M66
C3201M1	21667009166	R3259M1	0613952M66
C3203M1	2113955D37	R3260M1	0613952M66
C3204M1	2113955D37	R3261M1	0613952R01
C3205M1	21667009166	R3262M1	0613952R10
C3206M1	21667009166	R3263M1	NOT PLACED
C3208M1	2113956C37	R3264M1	0613952R01
C3209M1	2113945Y02	R3265M1	0613952M66
C3210M1	2113945Y02	R3266M1	0613952R01
C3211M1	2113945A11	R3267M1	NOT PLACED
C3212M1	2113955D37	R3268M1	0613952R01
C3213M1	2113945A03	R3269M1	0613952M66
C3214M1	2113955D37	R3270M1	0613952R01
C3215M1	2113956F49	R3271M1	NOT PLACED
C3216M1	2113945Y02	R3272M1	0613952R01
C3217M1	2113956B91	R3273M1	0613952M66
C3218M1	2113956A51	R3274M1	0613952R10
C3219M1	2113956A51	R3275M1	0613952R10

Circuit Ref.	Motorola Solutions Part No.	Circuit Ref.	Motorola Solutions Part No.
C3220M1	2113946F05	R3276M1	0613952R10
C3221M1	2113945Y02	R3277M1	0613952R10
C3222M1	2113956A51	R3278M1	0613952R01
C3223M1	2113945Y02	R3279M1	NOT PLACED
C3224M1	2113946F05	R3280M1	NOT PLACED
C3225M1	2113945Y02	R3281M1	NOT PLACED
C3226M1	NOT PLACED	R3282M1	0613952R66
C3227M1	2113946F05	R3283M1	0613952R66
C3228M1	2113945Y02	R3285M1	0613952R01
C3229M1	2113956A51	R3286M1	0613952R66
C3230M1	2113945Y02	R3287M1	0613952R66
C3231M1	2113945Y02	R3288M1	0613952R01
C3232M1	2113945Y02	R3289M1	0613952R01
C3233M1	2113945A09	R3290M1	NOT PLACED
C3234M1	2113945Y02	R3291M1	NOT PLACED
C3235M1	21012102001	R3292M1	0613952R66
C3236M1	2113945C31	R3293M1	0613952R66
C3237M1	21009337414	R4001M1	0613952R66
C3238M1	2113945A09	R4003M1	0613952R66
C3239M1	2113945A09	R4006M1	0613952Q37
C3240M1	2113956B91	R4007M1	0613952Q37
C3241M1	2113956B91	R4008M1	0613952R01
C3242M1	2113945C31	R4010M1	0613952R01
C3243M1	2113955D37	R4013M1	0613952Q42
C3244M1	2113956B91	R4015M1	0613952Q37
C3245M1	2113955D37	R4021M1	0613952R66
C3246M1	2113945C31	R4024M1	0613952R01
C3247M1	2113945Y02	R4025M1	0613952R01
C3248M1	2113945Y02	R4026M1	0613952R66
C3249M1	2113956B91	R4027M1	0613952R66
C3250M1	2113956B91	R4028M1	0613952R01
C4000M1	2113945Y02	R4029M1	0613952R01
C4001M1	2113945Y02	R4030M1	0613952R01
C4002M1	2113945Y02	R4031M1	0613952R01
C4003M1	2113945Y02	R4032M1	0613952R66

Circuit Ref.	Motorola Solutions Part No.	Circuit Ref.	Motorola Solutions Part No.
C4010M1	21667009166	R4033M1	0613952M43
C4011M1	21667009166	R4034M1	0613952M43
C4012M1	21667009166	R4035M1	0613952R66
C4013M1	21667009166	R4036M1	0613952R66
C4014M1	21667009166	R4037M1	0613952R01
C4015M1	21667009166	R4038M1	0613952R01
C4019M1	21667009166	R4039M1	NOT PLACED
C4020M1	21667009166	R4040M1	NOT PLACED
C4021M1	21667009166	R4041M1	NOT PLACED
C4022M1	21667009166	R4100M1	0613952R01
C4023M1	21667009166	R4101M1	0613952Q77
C4025M1	21667009166	R4102M1	0613958H83
C4026M1	21667009166	R4103M1	0613952Q85
C4027M1	21667009166	R4104M1	0613952Q89
C4028M1	21667009166	R4105M1	0613952Q89
C4029M1	21667009166	R4106M1	0613952Q89
C4030M1	21667009166	R4107M1	0613952R01
C4100M1	21667009166	R4108M1	0613952Q89
C4101M1	21667009166	R4109M1	0613952N58
C4103M1	21667009166	R4110M1	0613952Q85
C4104M1	21667009166	R4111M1	0613952Q85
C4105M1	21667009166	R4112M1	0613952R01
C4106M1	21667009166	R4113M1	0613952R01
C4107M1	21667009166	R4114M1	0613952Q89
C4108M1	21667009166	R4115M1	0613952N58
C4109M1	21667009166	R4116M1	0613952Q89
C4110M1	21667009166	R4117M1	0613952R01
C4112M1	21667009166	R4118M1	0613952R01
C4113M1	21667009166	R4119M1	0613952R01
C4114M1	21667009166	R4120M1	0613952N58
C4115M1	21667009166	R4121M1	0613952Q85
C4116M1	21667009166	R4122M1	0613952Q85
C4117M1	21667009166	R4123M1	0613952N58
C4118M1	21667009166	R4124M1	0613952N58
C4119M1	21667009166	R4125M1	0613952Q85

Circuit Ref.	Motorola Solutions Part No.	Circuit Ref.	Motorola Solutions Part No.
C4200M1	2113945Y02	R4126M1	0613952Q85
C4201M1	2113945Y02	R4127M1	0613952Q85
C4202M1	21667009166	R4128M1	0613952R01
C4203M1	21667009166	R4200M1	0613952R66
C4204M1	NOT PLACED	R4201M1	0613952R66
C4205M1	21667009166	R4202M1	0613952R66
C4206M1	21667009166	R4203M1	0613952R66
C4207M1	21667009166	R4204M1	0613952R66
C4208M1	21667009166	R4205M1	0613952R66
C4209M1	21667009166	R4206M1	0613952R66
C4210M1	21667009166	R4207M1	0613952R66
C4211M1	21667009166	R4208M1	0613952R66
C4212M1	21667009166	R4209M1	HZ000375A01
C4213M1	21667009166	R4210M1	HZ000375A01
C4214M1	21667009166	R4211M1	HZ000375A01
C4218M1	21667009166	R4212M1	HZ000375A01
C4219M1	21667009339	R4213M1	HZ000375A01
C4220M1	21667009339	R4214M1	HZ000375A01
C4221M1	21667009339	R4215M1	0613952R66
C4222M1	21667009339	R4216M1	0613952R66
C4223M1	21667009339	R4217M1	0613952R66
C4224M1	21667009166	R4218M1	0613952R66
C4225M1	21667009166	R4301M1	NOT PLACED
C4226M1	21667009339	R4302M1	0613952R66
C4300M1	NOT PLACED	R4303M1	0613952R66
C4301M1	NOT PLACED	R4304M1	0613952R66
C4302M1	NOT PLACED	R4305M1	0613952R66
C4303M1	NOT PLACED	R4306M1	0613952R66
C4304M1	21667009166	R4307M1	0613952R66
C4305M1	21667009376	R4309M1	NOT PLACED
C4306M1	21667009381	R4310M1	0613952R66
C4307M1	NOT PLACED	R4311M1	0613952R66
C4308M1	NOT PLACED	R4312M1	0613952R66
C4309M1	21667009166	R4313M1	NOT PLACED
C4310M1	21667009166	R4314M1	0613952R66

Circuit Ref.	Motorola Solutions Part No.	Circuit Ref.	Motorola Solutions Part No.
C4311M1	2113945Y02	R4315M1	0613952R66
C4312M1	2113945Y02	R4316M1	0613952R66
C4313M1	21667009166	R4317M1	0613952R66
C4314M1	NOT PLACED	RT0900M6	0615585H01
C4401M1	NOT PLACED	SH0000M2	26012095001
C4402M1	NOT PLACED	SH0001M2	26012095001
C4403M1	NOT PLACED	SH0002M2	26012097001
C4404M1	NOT PLACED	SH0003M2	26012094001
C4405M1	NOT PLACED	SH0004M2	26012094001
C4406M1	NOT PLACED	SH0200M7	26012095001
C4407M1	NOT PLACED	SH0300M7	26012095001
C4408M1	NOT PLACED	SH0400M4	26012096001
C4409M1	NOT PLACED	SH0401M4	26012096001
C4410M1	NOT PLACED	SH0402M4	26012098001
C4411M1	NOT PLACED	SH0403M4	26012098001
C4412M1	21667009166	SH0500M3	26012098001
C4413M1	21667009166	SH0501M3	NOT PLACED
C4414M1	21667009166	SH0850M6	26012100001
C4415M1	21667009166	SH0900M6	2686425Z02
C4417M1	21667009166	SH0901M6	2686425Z02
C4418M1	21667009166	SH3100M1	NOT PLACED
C4419M1	21667009166	SP3000M6	NOT PLACED
D0000M2	4815011H01	SP3001M6	NOT PLACED
D0001M2	4815011H01	T0000M2	24012146001
D0400M4	4884800Y03	T0400M4	2515121H01
D0401M4	4813974A19	T0401M4	2515121H01
D0402M4	4813974A19	U0000M2	51009877001
D0403M4	4884800Y03	U0001M2	5109731C48
D0404M4	4815090H01	U0002M2	4802197J95
D0500M3	4813974A19	U0200M7	5186310Y39
D0700M6	4813974A06	U0500M3	4802197J95
D0875M6	48012160001	U0901M6	5180390L83
D0876M6	4886622Y06	U0902M6	51012221001
D0877M6	48012160001	U0903M6	5115022H01
D0900M6	48012181001	U0904M6	5109731C48

Circuit Ref.	Motorola Solutions Part No.	Circuit Ref.	Motorola Solutions Part No.
D0950M6	4813974A21	U0905M6	5109731C48
D0951M6	4813974A21	U1000M1	5171320H01
D3000M6	4813978P07	U1001M1	51012295001
D3104M1	4885489Y01	U1002M1	5189139P01
D3160M1	4813978C02	U1003M1	5175772B56
D3161M1	4813978C02	U1004M1	5175772B56
E0000M2	24012095001	U1005M1	5164852H47
E0001M2	24012095001	U1006M1	5185493Y01
E0002M2	NOT PLACED	U1007M1	5189139P01
E0003M2	24012095001	U1008M1	5189139P01
E0004M2	24012095001	U1009M1	5115001H02
E0005M2	24012095001	U1010M1	5171320H01
E0006M2	24012095001	U2000M1	MM000157A01
E0007M2	24012095001	U2001M1	MM000129A01
E0008M2	24012095001	U3000M6	5116525H01
E0009M2	24012095001	U3001M6	4813973M07
E0010M2	24012095001	U3002M6	51012133001
E0200M7	24012095001	U3100M1	0104039J08
E0300M7	24012095001	U3101M1	5114014A01
E0401M4	24012107027	U3102M1	51012069001
E0402M4	24012107027	U3103M1	51012142001
E0403M4	24012107027	U3104M1	5171590Y73
E0404M4	24012107027	U3105M1	5114610F01
E0500M3	24012095001	U3106M1	51012140001
E0700M6	24012102001	U3107M1	51012140001
E0701M6	24012102001	U3108M1	51012138001
E0703M6	24012102001	U3109M1	5164015H94
E1000M1	7686949J15	U3110M1	51012208001
E1001M1	7686949J15	U3111M1	5188690V02
E1002M1	7686949J15	U3112M1	5114004A35
E1003M1	7686949J15	U3113M1	5188690V02
E1004M1	7686949J15	U3114M1	NOT PLACED
E1005M1	7686949J15	U3115M1	5185937Y01
E1006M1	7685268E01	U3200M1	51009415001
E3000M6	24012102001	U3201M1	5114016A18

Circuit Ref.	Motorola Solutions Part No.	Circuit Ref.	Motorola Solutions Part No.
E3100M1	24012102001	U3204M1	51009509001
E3101M1	2485410Y02	U3205M1	5114016A18
E3102M1	2485410Y02	U4000M1	51012082001
E3103M1	2485410Y02	U4001M1	51012082001
E3104M1	7686949J22	U4100M1	5189139P01
E3105M1	7686949J22	U4200M1	NOT PLACED
E3106M1	7686949J22	U4201M1	NOT PLACED
E3107M1	7686949J22	U4300M1	51012082001
E3108M1	7686949J22	U4301M1	51012082001
E3109M1	7686949J22	VR0001M2	4815096H01
E3110M1	7686949J22	VR0200M7	4805656W87
E3111M1	7686949J22	VR0201M7	4805656W87
E3113M1	7686949J22	VR0202M7	4805656W87
E3200M1	24012102001	VR0203M7	4805656W87
E3201M1	24012102001	VR0204M7	4805656W87
E3202M1	24012107027	VR0205M7	4805656W87
E3203M1	24012102001	VR0206M7	4805656W87
E3204M1	24012102001	VR0207M7	4805656W87
E4000M1	24012107027	VR0208M7	4805656W87
E4001M1	7688697V05	VR0209M7	NOT PLACED
E4002M1	24012107027	VR0210M7	4805656W87
E4003M1	NOT PLACED	VR0211M7	4805656W87
E4004M1	24012102001	VR0214M7	4805656W87
E4005M1	2485410Y02	VR0215M7	4805656W87
E4100M1	7686949J14	VR0400M4	4805656W87
E4101M1	24012107027	VR0401M4	4805656W87
E4102M1	NOT PLACED	VR0402M4	4805656W87
E4103M1	NOT PLACED	VR0403M4	4805656W87
E4104M1	NOT PLACED	VR0404M4	4805656W87
E4200M1	24012107027	VR0405M4	4805656W87
E4201M1	24012107027	VR0406M4	4805656W87
E4202M1	24012107027	VR0407M4	4805656W87
E4300M1	24012107027	VR3000M6	48012202001
E4405M1	24012107027	VR3002M6	4813977M10
E4406M1	7686949J22	VR3103M1	48012095001

Circuit Ref.	Motorola Solutions Part No.	Circuit Ref.	Motorola Solutions Part No.
E4407M1	7686949J22	VR3104M1	48012095002
E4408M1	24012107027	VR3105M1	4813977M10
E4409M1	24012102001	VR3200M1	48012049001
F4000M1	65012019001	VR3201M1	4813977A48
FL0500M3	9116854H02	VR3202M1	4813977A48
FL4000M1	24012038001	VR4000M1	4813977M13
FL4001M1	24012038001	VR4001M1	4813977A48
J0700M6	09009348002	VR4002M1	48012153001
J4000M1	0915767H01	VR4100M1	4813977A48
J4001M1	0915556H01	VR4101M1	4813977A48
J4100M1	0916017H01	VR4102M1	4813977A48
J4200M1	09012053001	VR4103M1	4813977A48
J4400M1	09012053001	VR4104M1	48012049001
L0000M2	24012154001	VR4105M1	4813977M13
L0001M2	24667001020	VR4106M1	4813977A48
L0002M2	2414017K32	VR4107M1	4813977A48
L0003M2	24667001031	VR4108M1	4813977A48
L0004M2	24009343017	VR4109M1	4813977A50
L0005M2	24667001017	VR4110M1	4815040H01
L0200M7	24667001031	VR4111M1	48012153001
L0201M7	24667001031	Y0000M2	4875185M05
L0202M7	2415385H01	-	-



NOTICE: The suffix "M1", "M2", and so on from the Circuit Ref. is removed from the schematic and overlays.

8.9

Bluetooth/Wi-Fi/GNSS (PMLN7252_S) Expansion Board Service Information

8.9.1

Allocation of Schematic and Circuit Board

Bluetooth/Wi-Fi/GNSS (PMLN7252_S) Schematic Diagram and Parts List for PC000942A01-AA

Diagrams:

- [Figure 263: Expansion Board Top Side PCB No. PC000942A01-AA on page 571](#)
- [Figure 264: Expansion Board Bottom Side PCB No. PC000942A01-AA on page 572](#)

- [Figure 265: Expansion Board Schematic Diagram \(Sheet 1 of 4\) on page 573](#)
 - [Figure 266: Expansion Board Schematic Diagram \(Sheet 2 of 4\) on page 574](#)
 - [Figure 267: Expansion Board Schematic Diagram \(Sheet 3 of 4\) on page 575](#)
 - [Figure 268: Expansion Board Schematic Diagram \(Sheet 4 of 4\) on page 576](#)
- [Parts List for PC000942A01-AA on page 577](#)

Figure 264: Expansion Board Bottom Side PCB No. PC000942A01-AA

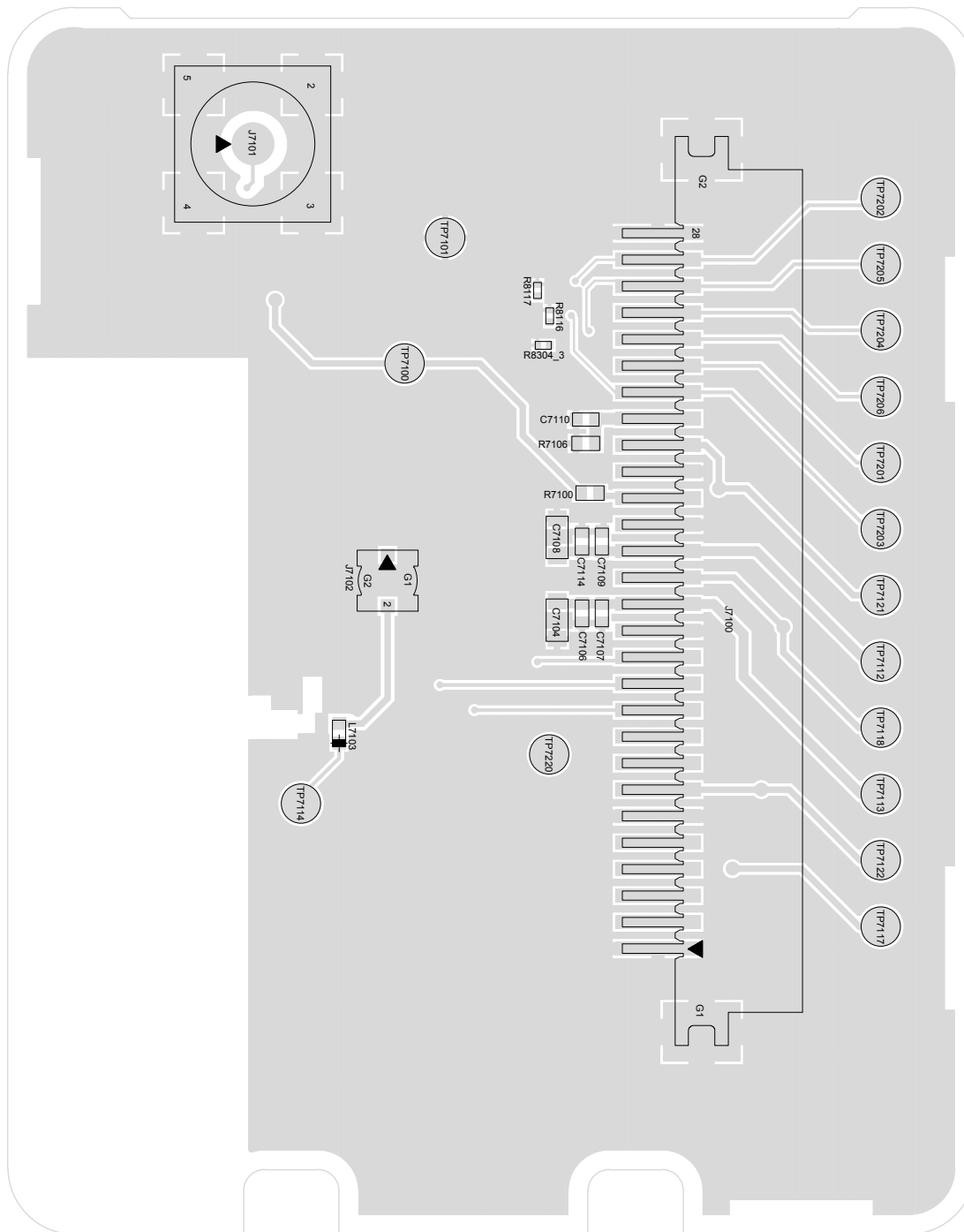
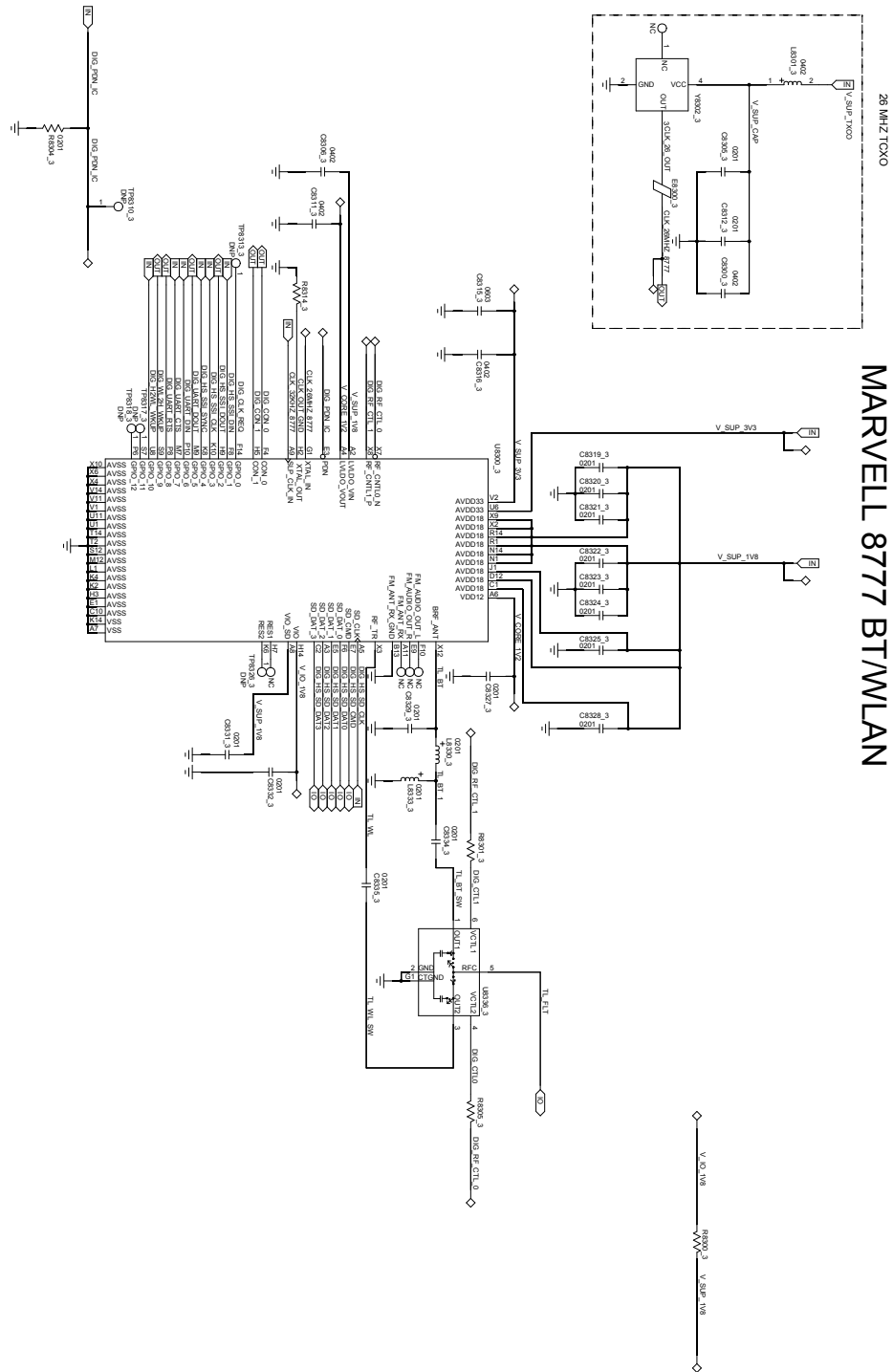

Figure 268: Expansion Board Schematic Diagram (Sheet 4 of 4)



8.9.1.2

Parts List for PC000942A01-AA

Table 28: Bluetooth/Wi-Fi/GNSS (PMLN7252_S) Expansion Board Parts List

Circuit Ref.	Motorola Solutions Part No.	Circuit Ref.	Motorola Solutions Part No.
C7100	21667009370	C8328_3	2113946U01
C7101	21667009174	C8329_3	21013048001
C7102	2113946S35	C8331_3	2113946U01
C7103	NOT PLACED	C8332_3	2113946U01
C7104	2113946S35	C8334_3	CA000445A01
C7106	2113945Y02	C8335_3	21667013140
C7107	21667009370	E7100	7688697V14
C7108	2113946S35	E8100	7686949J22
C7109	2113945Y02	E8102	7688697V04
C7110	NOT PLACED	E8103	7688697V04
C7114	21667009370	E8300_3	7688697V14
C7127	2113945Y02	FL7101	9109674L58
C7128	NOT PLACED	FL7102	91012057001
C7129	21667009355	J7100	09012053001
C7130	21667009355	J7101	0909901V02
C7131	21012182001	J7102	CN000512A01
C7132	21012043035	L7101	24009344027
C7133	2113956A51	L7103	2475122C29
C7134	2113956A51	L7104	2475122C12
C7135	2113956A51	L8301_3	2475122C28
C7136	2113956A51	L8330_3	IN000095A01
C7137	2113956A51	L8333_3	IN000095A01
C7138	2170282H06	R7100	0613952R66
C7139	2113956A51	R7105	0613952N01
C7140	2113956A51	R7106	0613952N01
C7141	21667009370	R8100	0613952V09
C7142	2113944A52	R8101	0613952V30
C8100	2187893N01	R8115	0613952R66
C8101	2187893N01	R8116	0613952V69
C8102	21667013140	R8117	NOT PLACED
C8103	NOT PLACED	R8300_3	0613952R66
C8104	NOT PLACED	R8301_3	0613952Y66

Circuit Ref.	Motorola Solutions Part No.	Circuit Ref.	Motorola Solutions Part No.
C8105	NOT PLACED	R8304_3	0613952X73
C8106	NOT PLACED	R8305_3	0613952Y66
C8107	2113946D05	R8314_3	0613952Y66
C8300_3	21009304001	SH7100	2680514Z02
C8305_3	21667012146	TP8310_3	NOT PLACED
C8306_3	21009304001	TP8313_3	NOT PLACED
C8311_3	21009304001	TP8317_3	NOT PLACED
C8312_3	2113946U01	TP8318_3	NOT PLACED
C8315_3	21012129001	TP8326_3	NOT PLACED
C8316_3	21009304001	U7103	IC001223A01
C8319_3	2113946U01	U8100	5171734H01
C8320_3	2113946U01	U8300_3	IC000285A01
C8321_3	2113946U01	U8336_3	HZ000243A01
C8322_3	2113946U01	VR7100	4813977A43
C8323_3	2113946U01	Y7101	93012017001
C8324_3	2113946U01	Y8302_3	HZ000202A01
C8325_3	2113946U01	PCB	PC000942A01
C8327_3	2113945F07	-	-

8.10

Generic Option Board (GOB) Service Information

8.10.1

Allocation of Schematic and Circuit Board

This chapter shows the PCB component layouts, schematics, and parts list for the GOB circuits.

GOB Schematic Diagram and Parts List for PC000957A01-CA

Diagrams:

- [Figure 269: GOB Top Side PCB No. PC000957A01-CA on page 579](#)
- [Figure 270: GOB Bottom Side PCB No. PC000957A01-CA on page 580](#)
- [Figure 271: GOB Schematic Diagram on page 581](#)

[Parts List for PC000957A01-CA on page 582](#)

8.10.1.1

Circuit Board and Schematic Diagram for PC000957A01-CA

Figure 269: GOB Top Side PCB No. PC000957A01-CA

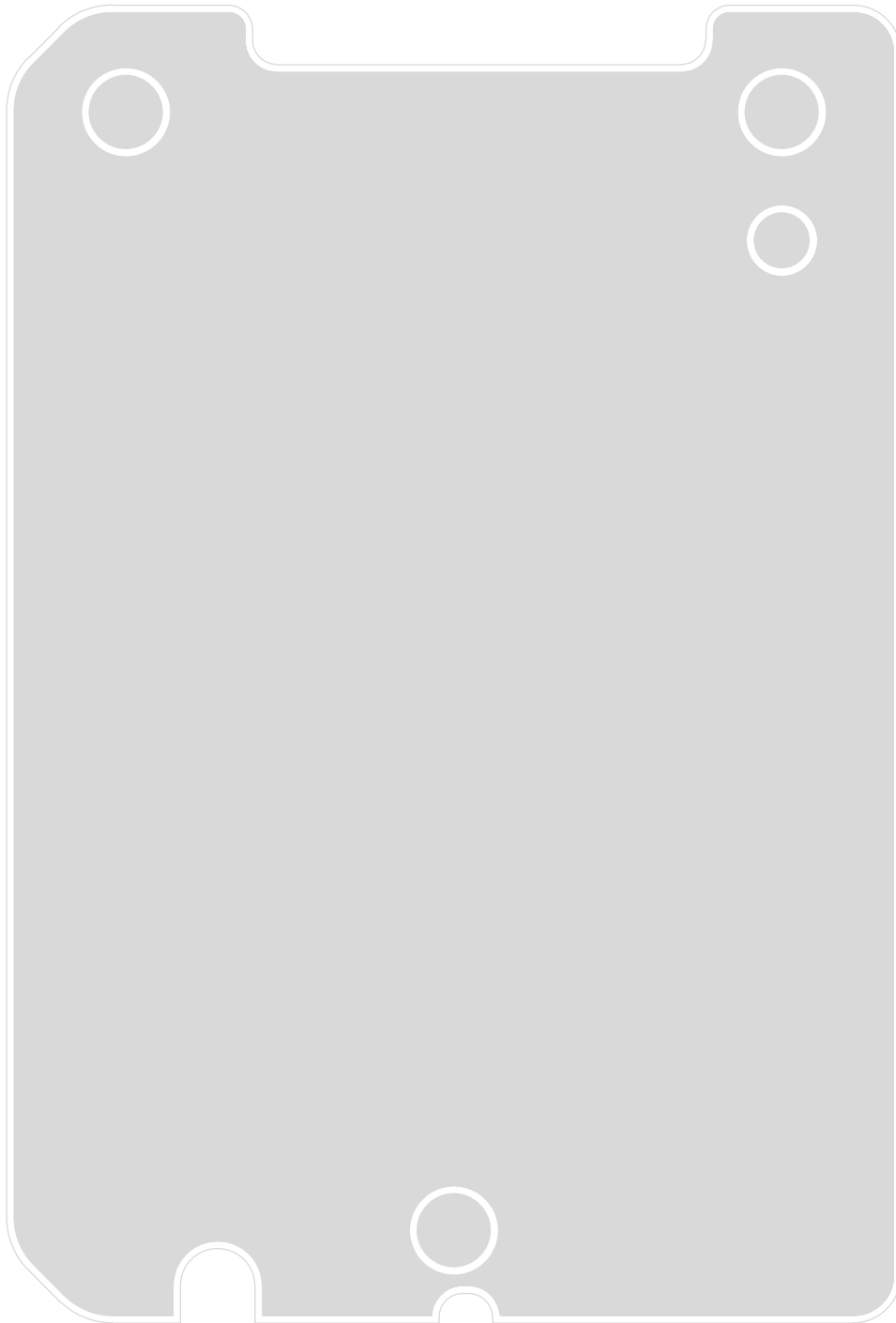

Figure 270: GOB Bottom Side PCB No. PC000957A01-CA

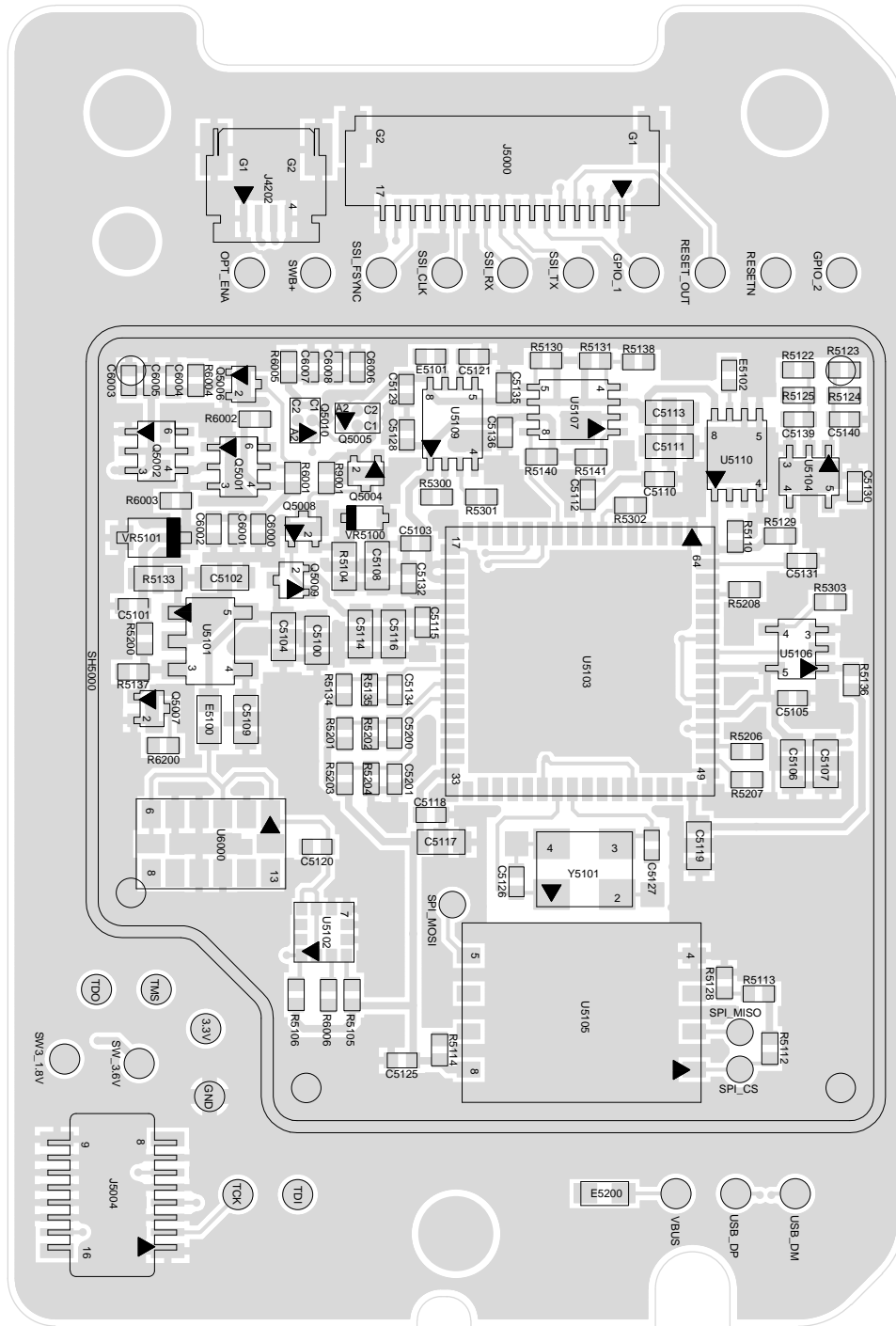
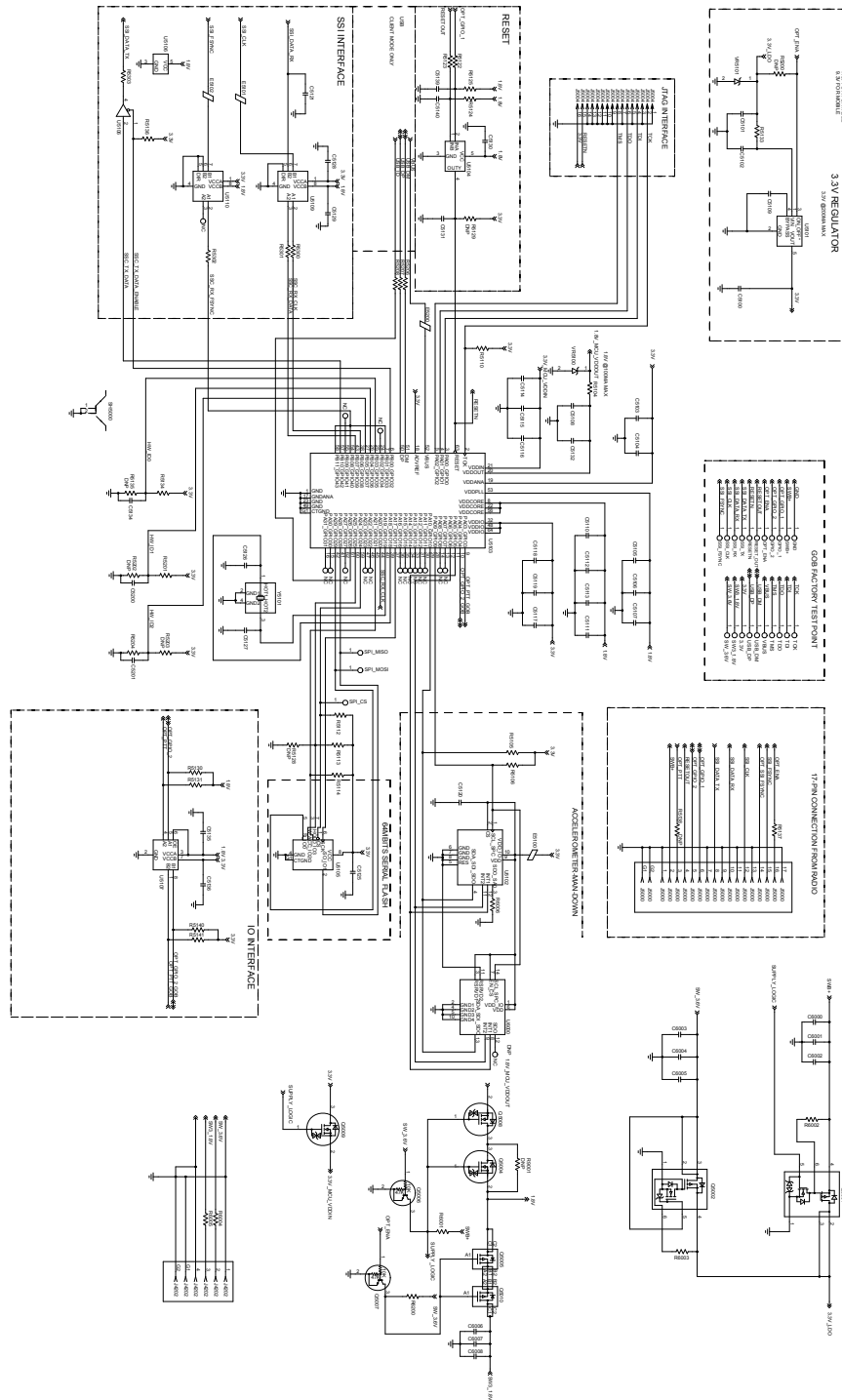

Figure 271: GOB Schematic Diagram



8.10.1.2

Parts List for PC000957A01-CA

Table 29: GOB Parts List

Circuit Ref.	Motorola Solutions Part No.	Circuit Ref.	Motorola Solutions Part No.
C5100	2113946S35	Q5009	48012088001
C5101	2113945A05	Q5010	4870370A72
C5102	2113946S35	R5104	0613952G67
C5103	2113945Y02	R5105	0613952R01
C5104	2113945D01	R5106	0613952R01
C5105	2113945A11	R5110	0613952R01
C5106	2113945D01	R5112	0613952R25
C5107	2113956B21	R5113	0613952R25
C5108	2113956B21	R5114	0613952R25
C5109	2113741F49	R5122	0613952Q25
C5110	2113945A11	R5123	0613952Q25
C5111	2113945D01	R5124	0613952R01
C5112	2113945Y02	R5125	0613952R01
C5113	2113956B21	R5128	NOT PLACED
C5114	2113956B21	R5129	NOT PLACED
C5115	2113945Y02	R5130	0613952R01
C5116	2113945D01	R5131	0613952R01
C5117	2113945D01	R5133	0613952G67
C5118	2113945Y02	R5134	0613952R01
C5119	2113956B21	R5135	NOT PLACED
C5120	2113946B04	R5136	0613952R01
C5121	2113944A46	R5137	0613952R66
C5125	2113945Y02	R5138	NOT PLACED
C5126	2115153H22	R5140	0613952R01
C5127	2115153H22	R5141	0613952R01
C5128	2113945Y02	R5200	NOT PLACED
C5129	2113945Y02	R5201	0613952R01
C5130	2113945Y02	R5202	NOT PLACED
C5131	2113945Y02	R5203	NOT PLACED
C5132	2113945A05	R5204	0613952R01
C5134	2113945Y02	R5206	0613952K58
C5135	2113945Y02	R5207	0613952K58

Circuit Ref.	Motorola Solutions Part No.	Circuit Ref.	Motorola Solutions Part No.
C5136	2113945Y02	R5208	0613952R01
C5139	2113945Y02	R5300	0613952Q33
C5140	2113945Y02	R5301	0613952Q33
C5200	2113945Y02	R5302	0613952Q33
C5201	2113945Y02	R5303	0613952Q73
C6000	21667009156	R6001	0613952R01
C6001	21667009166	R6002	0613952P01
C6002	2113945A11	R6003	0613952P01
C6003	21667009156	R6004	0613952R66
C6004	21667009166	R6005	0613952R66
C6005	2113945A11	R6006	0613952R01
C6006	2113945A11	R6200	0613952R01
C6007	21667009166	R9001	NOT PLACED
C6008	21667009156	SH5000	26012099001
E5100	7686949J08	U5101	5171417N02
E5101	530004-001-00	U5102	IC000643A01
E5102	530004-001-00	U5103	51012009003
E5200	24001720002	U5104	51012266001
J4202	CN000225A01	U5105	51012336001/ MM000383A01
J5000	09012068001	U5106	5188085K03
J5004	2887818K02	U5107	51012205001
Q5001	48012274001	U5109	5171767H01
Q5002	4888695V01	U5110	5171767H01
Q5004	48012088001	U6000	NOT PLACED
Q5005	4870370A72	VR5100	48012131001
Q5006	4816134H01	VR5101	4815040H01
Q5007	4816134H01	Y5101	93012000001
Q5008	48012088001	PCB	PC000957A01

Appendix A

Replacement Parts Ordering

Basic Ordering Information

Some replacement parts, spare parts, and/or product information can be ordered directly on Motorola Solutions local distribution organization or through Motorola Online. While parts may be assigned with a Motorola Solutions part number, this does not guarantee that they are available from Motorola Solutions Radio Products and Solutions Organization (RPSO). Some parts may have become obsolete and no longer available in the market due to cancellations by the supplier. If no Motorola Solutions part number is assigned, the part is normally not available from Motorola Solutions, or is not a user-serviceable part. Part numbers appended with an asterisk are serviceable by Motorola Solutions Depot only.

Orders for replacement parts, kits, and assemblies should be placed directly on Motorola Solutions local distribution organization or through Motorola Online. When ordering replacement parts or equipment information, the complete identification number should be included. This applies to all components, kits, and chassis. If the component part number is not known, the order should include the number of the chassis or kit of which it is a part, and sufficient description of the desired component to identify it.

Request for help in identification if non-referenced spare parts should be directed to the Customer Care organization of Motorola Solutions local area representation. Orders for replacement parts, kits, and assemblies should be placed directly on Motorola Solutions local distribution organization or by using Motorola Online.

Motorola Online

Motorola Online users can access our online catalog at <https://businessonline.motorolasolutions.com>.

To register for online access:

Please call 1-800-422-4210 (for U.S. and Canada Service Centers only). International customers can obtain assistance at <https://businessonline.motorolasolutions.com>.

Types of Orders

Mail Orders

Mail orders are only accepted by the U.S. Federal Government Markets Division (USFGMD).

Motorola
Solutions

7031 Columbia Gateway Drive

3rd Floor - Order Processing

Columbia, MD 21046

U.S.A.

Telephone Orders and Parts Identification

- RPSO
(United States and Canada)
7:00 AM to 7:00 PM (Central Standard Time)
-

Types of Orders

	Monday through Friday (Chicago, U.S.A.) 1-800-422-4210 1-847-538-8023 (United States and Canada) <ul style="list-style-type: none">• USFGMD 1-800-826-1913 Federal Government Parts - Credit Cards Only 8:30 AM to 5:00 PM (Eastern Standard Time)
Fax Orders	RPSO (United States and Canada) 1-800-622-6210 1-847-576-3023 (United States and Canada) USFGMD (Federal Government Orders) 1-800-526-8641 (For Parts and Equipment Pur- chase Orders)

Product Customer Service

RPSO (United States and Canada)

1-800-927-2744



NOTICE: The Motorola Solutions RPSO was formerly known as the Radio Products Services Division (RPSD) and/or the Accessories and Aftermarket Division (AAD).

Appendix B

Motorola Solutions Service Centers

If a unit requires further testing, knowledge and/or details of component level troubleshooting or service than is customarily performed at the basic level, please send the radio to a Motorola Solutions Service Center as listed below.

Types of Center	Address	Telephone Number
Motorola Solutions Service Centers	1220 Don Haskins Drive Suite A El Paso, TX 79936	915-872-8200
Motorola Solutions Federal Technical Center	10105 Senate Drive Lanham, MD 20706	1800-969-6680 Fax: 1800-784-4113
Motorola Solutions Canadian Technical Logistics Center	181 Whitehall Drive Markham, Ontario L3R 9T1	Toll Free: 1-800-543-3222

Glossary

This glossary contains an alphabetical listing of terms and their definitions that are applicable to portable and mobile subscriber radio products. All terms do not necessarily apply to all radios, and some terms are merely generic in nature.

Analog Refers to a continuously variable signal or a circuit or device designed to handle such signals.

Band Frequencies allowed for a specific purpose.

Bluetooth (BT) A wireless protocol utilizing short-range communications over short distances.

Customer Programming Software (CPS) Software with a graphical user interface containing the feature set of a radio.

Default A pre-defined set of parameters.

Digital Refers to data that is stored or transmitted as a sequence of discrete symbols from a finite set; most commonly this means binary data represented using electronic or electromagnetic signals.

Digital Private-Line (DPL) A type of digital communications that utilizes privacy call, as well as memory channel and busy channel lock out to enhance communication efficiency.

Federal Communications Commission (FCC) Regulates interstate and international communications by radio, television, wire, satellite and cable in all 50 states, the District of Columbia, and U.S. territories. It was established by the Communications Act of 1934 and operates as an independent U.S. government agency overseen by Congress. The commission is committed to being a responsive, efficient and effective agency capable of facing the technological and economic opportunities of the new millennium.

Frequency Number of times a complete electromagnetic-wave cycle occurs in a fixed unit of time (usually one second).

Global Navigation Satellite System (GNSS) GNSS uses satellites from the GPS, GLONASS, and BeiDou systems.

- Global Positioning System (GPS)
 - It includes Satellite-Based Augmentation System (SBAS).
 - Method of location based on reception of multiple satellite signals by a device on the ground or in an airplane.
- Global Navigation Satellite System (GLONASS)
- BeiDou Navigation Satellite System (BDS)
 - Chinese Satellite Navigation System.

General-Purpose Input/Output (GPIO) Pins whose function is programmable.

Integrated Circuit (IC) An assembly of interconnected components on a small semiconductor chip, usually made of silicon. One chip can contain millions of microscopic components and perform many functions.

kilohertz (kHz) One thousand cycles per second. Used especially as a radio-frequency unit.

Liquid-Crystal Display (LCD) An LCD uses two sheets of polarizing material with a liquid-crystal solution between them. An electric current passed through the liquid causes the crystals to align so that light cannot pass through them.

Light Emitting Diode (LED) An electronic device that lights up when electricity is passed through it.

Motorola Digital Communications (MDC) A Motorola Solutions proprietary signaling scheme permitting the transfer of data communications at the rate of 1200 bits per second. Designed specifically for high reliability in the land-mobile radio environment. Digital encoding allows a much greater amount of information to pass over the channel with each message than with alternative tone encoding methods. Some features include: PTT ID, Emergency, Call Alert, Emergency Alarm, Voice Selection Call (SelCall), Radio Check, and Monitor.

Megahertz (MHz) One million cycles per second. Used especially as a radio-frequency unit.

Paging One-way communication that alerts the receiver to retrieve a message.

Printed Circuit Board (PC Board) A circuit manufactured so that many or all of the components are attached to a non-conductive circuit board with copper strips on one or both sides to replace wires.

Private-Line Tone Squelch (PL) A continuous sub-audible tone that is transmitted along with the carrier.

Programming Cable A cable that allows the CPS to communicate directly with the radio using USB.

Receiver Electronic device that amplifies RF signals. A receiver separates the audio signal from the RF carrier, amplifies it, and converts it back to the original sound waves.

Repeater Remote transmit/receive facility that re-transmits received signals in order to improve communications range and coverage (conventional operation).

Radio Frequency (RF) The portion of the electromagnetic spectrum between audio sound and infrared light (approximately 10 kHz to 10 GHz).

Signal An electrically transmitted electromagnetic wave.

Spectrum Frequency range within which radiation has specific characteristics.

Squelch Muting of audio circuits when received signal levels fall below a pre-determined value. With carrier squelch, all channel activity that exceeds the radio's preset squelch level can be heard.

Time-out Timer (TOT) A timer that limits the length of a transmission.

Tone Private Line (TPL) A continuous tone-coded squelch, which contains 29 codes. It is not compatible with DPL, and is common among all radio manufacturers.

Transceiver Transmitter-receiver: A device that both transmits and receives analog or digital signals.

| **Abbreviation:** XCVR

Transmitter Electronic equipment that generates and amplifies an RF carrier signal, modulates the signal, and then radiates it into space.

Ultra-High Frequency (UHF) The term for the International Telecommunication Union (ITU) Radio Band with a frequency range of 300 to 3000 MHz.

Universal Serial Bus (USB) An external bus standard that supports data transfer rates of 12 Mbps.

Wireless Fidelity (Wi-Fi) A mechanism used to wirelessly connect electronic devices.