

SYSTEMS SABER  
SECURENET  
Handie-Talkie Portable Radios  
146-174 MHz  
Service Manual

68P81067C10-0



**SYSTEMS SABER™**  
**SECURENET™**  
**Handie-Talkie® Portable Radio**  
 146 - 174 MHz

**SPECIFICATIONS**

GENERAL	TRANSMITTER	RECEIVER
<b>FREQUENCY RANGE:</b> 146-174MHz <b>BANDSPLITS:</b> 136-150.8MHz 146-162MHz 146-174MHz (Low-Power Only) 148-174MHz (H366 Option) 157-174MHz  <b>POWER SUPPLY:</b> Rechargeable Nickel-Cadmium Battery or Primary Battery  <b>BATTERY VOLTAGE:</b> Nominal: 7.5Vdc Range: 6 to 9Vdc  <b>TEMPERATURE RANGE</b> Operating: -30°C to +60°C Storage: -40°C to +85°C  <b>DIMENSIONS (HXWXD)</b> Less Battery: 4.42"x2.94"x1.18" (112.27x74.67x29.97 mm)  With Medium-Capacity Battery: 7.56"x2.94"x1.18" (192.02x74.67x29.97 mm)  With Ultra-High-Capacity Battery: 8.32"x2.94"x1.18" (211.33x74.67x29.97 mm)  <b>WEIGHT</b> <div style="text-align: right;"><b>Non-Keypad</b></div> Less Battery: 12.22 oz. (347 g)  With Medium-Capacity Battery: 23.87 oz. (678 g)  With Ultra-High-Capacity Battery: 25.49 oz. (724 g)  <div style="text-align: right;"><b>Keypad</b></div> Less Battery: 12.57 oz. (357 g)  With Medium-Capacity Battery: 24.23 oz. (688 g)	<b>RF POWER OUTPUT</b> Low-Power Models: 1 - 2.5 Watts High-Power Models: 2.5 - 6 Watts High-Power Models with H366 Option: 2 - 5 Watts  <b>FREQUENCY STABILITY</b> <b>(-30°C to +60°C; +25°C REF):</b> ±.0002%  <b>MODULATION:</b> Types 20K0F3E <b>(±5kHz for 100%</b> 20K0F1D <b>modulation @ 1000Hz)</b> 20K0F2D  <b>FM HUM AND NOISE</b> <b>(COMPANION RECEIVER):</b> -45dB  <b>SPURIOUS EMISSION</b> <b>(CONDUCTED AND RADIATED)</b> 2.5W: -71dBc 6.0W: -75dBc  <b>AUDIO DISTORTION:</b> 3% Maximum  <b>AUDIO FREQUENCY RESPONSE:</b> +1,-3dB <b>(6dB/OCTAVE PRE-EMPHASIS;</b> <b>300-3000Hz)</b>  <b>MAXIMUM FREQUENCY</b> <b>SEPARATION:</b> Full Bandsplit <b>(NO DEGRADATION)</b>	<b>SENSITIVITY</b> 20dBQ: 0.45uV Max. 12dB S: 0.35uV Max. Squelch (Programmable): 0.30uV Max.  <b>USEABLE BANDWIDTH:</b> 5kHz Minimum  <b>SELECTIVITY:</b> Adjacent channel: -80dB Fourth channel: -90dB  <b>INTERMODULATION:</b> -78dB  <b>FM HUM AND NOISE:</b> -45dB  <b>FREQUENCY STABILITY</b> <b>(-30°C to +60°C; +25°C REF):</b> ±.0002%  <b>AUDIO SPL (AT 30 cm</b> <b>WITH RATED AUDIO):</b> Weighted, 300-3000Hz 90dB Nominal  <b>RATED AUDIO OUTPUT:</b> 500mW (At less than 5% distortion)  <b>CHANNEL SPACING:</b> 30kHz  <b>MAXIMUM FREQUENCY</b> <b>SEPARATION:</b> Full Bandsplit <b>(NO DEGRADATION)</b>
<b>SECURENET</b>		
	<b>SCRAMBLE TYPE:</b> Digital <b>ENCRYPTION METHOD:</b> Multi-Register, Non-Linear Combiner <b>ENCRYPTION KEY INITIALIZATION:</b> Random <b>ENCRYPTION KEY GENERATION:</b> External, Hand-Held Microprocessor-Controlled Key loader Volatile Electronic Memory  <b>KEY STORAGE:</b> One <b>NUMBER OF KEYS PER RADIO:</b> Continuously-Variable Slope Delta <b>ANALOG-TO-DIGITAL CONVERSION:</b> (CVSD) Modulation  <b>VOICE SAMPLE RATE:</b> 12 Kilobits/Second	

All specifications are per EIA RS316B, unless noted  
 Specifications are subject to change without notice

Motorola, SYSTEMS SABER, SECURENET, Private-Line, Digital Private-Line, and Handie-Talkie are trademarks of Motorola Inc.

# MODEL CONFIGURATION

FACTORY ID	POWER LEVEL	FREQ.	SUBMERSIBLE	KEYPAD	DISPLAY
H33TUN5170CN	2.5W	146-174MHz	NO	None	None
H43TUN5170CN	6W	136-174MHz	NO	None	None
H33YUN5170CN	2.5W	146-174MHz	YES	None	None
H43YUN5170CN	6W	136-174MHz	YES	None	None
H33TUK5170CN	2.5W	146-174MHz	NO	3x5	LCD
H43TUK5170CN	6W	136-174MHz	NO	3x5	LCD

## SPECIALIZED TOOLS AND TEST EQUIPMENT

### SERVICE AIDS

NTN4720A	SECURENET Bypass Module
REN-4001A	Housing Eliminator (Allows key loading through the cable)
RPX-4665A	Field Modification Kit/RTX-4005A
RSX-4043A	Rotatorq Tool
RTK-4203A	Program/Test Cable
RTK-4208A	RF Coaxial Probe
RTL-4224A	Battery Eliminator
RTL-4238A	RF Cable
RTX-4005B	Portable Products Test Set
TKN8506A	Keyload Cable (Hand-held key loader to radio)
0180370B85 thru B86	Ungar Table Fixtures
0180386A81	Micro-Tip Soldering Iron
0180386A82	Static Protection Kit
5880348B33	SMA-BNC Adapter for RTL-4208A Probe
6680321B79	Phillips-Head Rotatorq Bit
6680334B48 thru B52	Ungar Service Heads
6680370B88	Frequency and On/Off Switch Spanner Nut Rotatorq Bit
6680370B89	Baseplate Spanner Nut Rotatorq Bit
6680370B90	Antenna Bushing Spanner Nut Rotatorq Bit
6680385A11	Module Extractor
6680387A59	Leadless Component Extractor
6680387A64	Heat Controller With Safety Stand
8407264N02	SYSTEMS SABER Controller Extender Cable (10-pin)

### TEST EQUIPMENT

R-1053A	Dual-Trace Oscilloscope
R-2045D	Communications Systems Analyzer with Secure Voice Option
S-1339A	RF Millivoltmeter
S-1347D	Power Supply
RTK-4237A	Battery Tester
RTL-4223A	Charger Tester

### FIELD PROGRAMMING EQUIPMENT

RVN-4051A	SYSTEMS SABER Field Programmer Software on 5 1/4-inch 360k Double-Density Disk
RVN-4052A	SYSTEMS SABER Field Programmer Software on 3 1/2-inch Disk
0180353A74	Radio Interface Box (RIB)
0180357A57	RIB Wall-Mounted Power Supply
3080369B71	Computer Interface Cable (PC-AT), 25-pin
3080369B72	Computer Interface Cable (PC-XT), 9-pin
68P81060C25	SYSTEMS SABER Field Programmer User's Guide

## CURRENT DRAINS (SEE NOTE)

	SYSTEMS SABER I	SYSTEMS SABER III
STANDBY	85	88
RECEIVE	215	218
H33 MODELS: 2.5-WATT	1500	1500
H43 MODELS: 6-WATT	3100	3100

**NOTE:** Drain specifications are in milliamperes at 7.5Vdc. These *typical* current drains apply to test mode, with the radio operating through the external antenna port. Current drains decrease in normal operation due to antenna switch drains and antenna loading.

## CLEANING

- Clean all external radio surfaces with a 0.5% solution of a mild dishwashing detergent in water (one teaspoon of detergent per gallon of water).
- Stronger cleaning agents may only be used to remove soldering flux from circuit boards after making repairs.
- Clean internal surfaces with water-activated optical wipes.

## CAUTION

*Never* allow any alcohol- or solvent-based product to contact any plastic or rubber radio part.

## RELATED PUBLICATIONS AVAILABLE SEPARATELY

SYSTEMS SABER I/III SECURENET OPERATING INSTRUCTIONS.....	68P81060C10
SYSTEMS SABER SECURENET THEORY/ MAINTENANCE MANUAL.....	68P81060C20
SYSTEMS SABER FIELD PROGRAMMER USER'S GUIDE.....	68P81060C25
SYSTEMS SABER SECURENET SERVICE MANUAL (UHF) .....	68P81066C95

# DISASSEMBLY/REASSEMBLY PROCEDURES

## 1. DISASSEMBLY

- a. **Turn off the radio** by rotating the on/off/volume control knob fully counterclockwise until you hear a click. Remove the universal connector cover or any accessory connected to the radio before beginning disassembly.

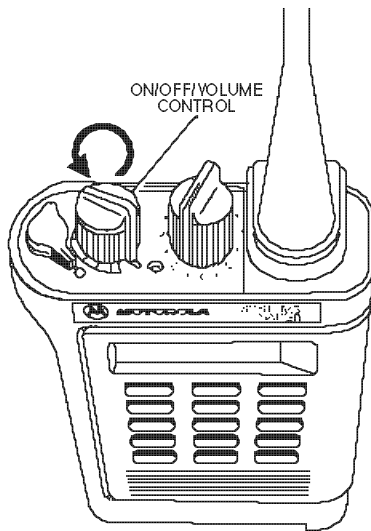

MAEPF-20609-O

- c. **Loosen the two slotted-spanner nuts** on the bottom of the radio using Rotorq tool bit No. 6680370B89. When loosened, the slotted-spanner nuts are captive and will spin freely without sepa-

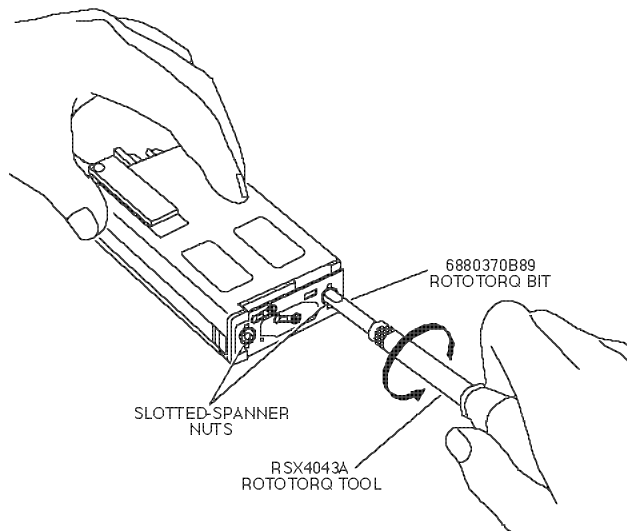

MAEPF-20610-O

- b. **Remove the battery** from the baseplate on the bottom of the radio housing by pushing the spring-loaded battery latch toward the top of the radio, and sliding the battery away from the latch until it clears the baseplate.

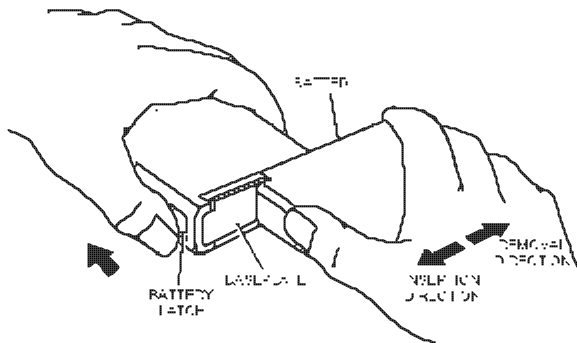

MAEPF-20185-O

- d. **Remove the frame assembly** from the radio housing by grasping the antenna at its base and pulling it gently upward. *Do not depress the PTT switch during removal and do not push on the*

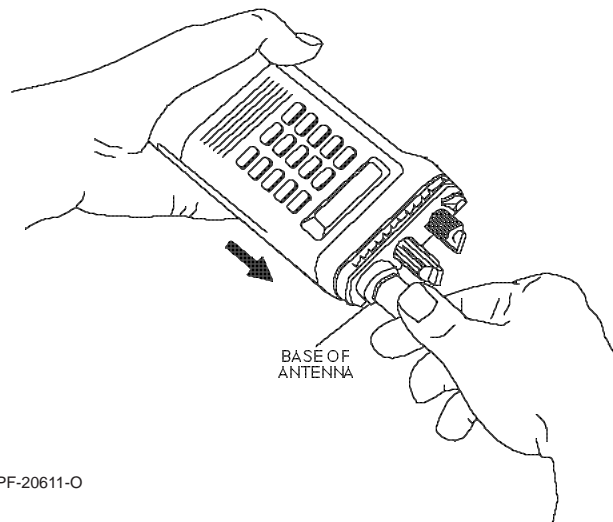

MAEPF-20611-O

*slotted-spanner nuts to lift the frame assembly.*

### CAUTION

Ensure that all static electricity safeguards are in place.

- e. With the speaker facing upward, **remove the speaker bracket assembly** by inserting a thin screwdriver blade between the frame and the bottom of the speaker bracket, and prying gently upward on the speaker bracket until it is disengaged from the frame.

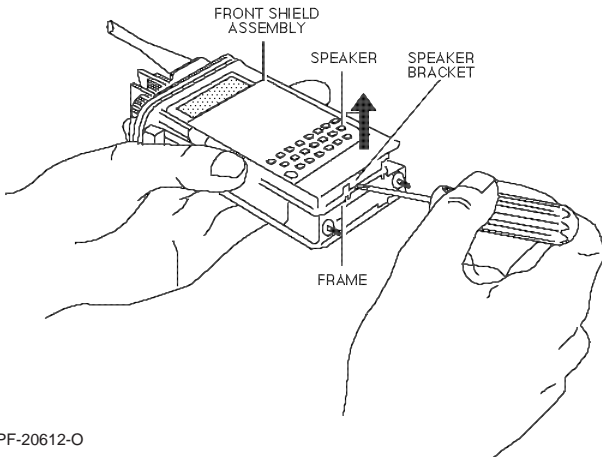

MAEPF-20612-O

- f. **Lift the speaker bracket assembly** away from the bottom of the frame assembly, then pull it out from under the plastic top panel. Be careful not to pull against the flexible circuits connecting the speaker bracket to the frame assembly.

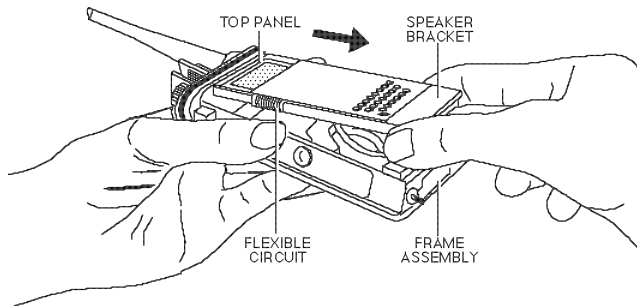

MAEPF-20613-O

- g. **Disconnect the interconnect flexible circuit** from the frame assembly by pulling the header straight out and away from the main printed circuit board.

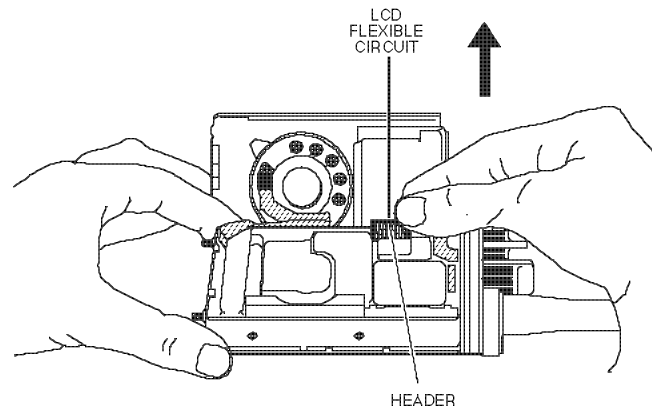

MAEPF-20959-O

- h. **Disconnect the speaker/microphone flexible circuit** from the frame assembly by pulling the connector straight out and away from the main printed circuit board.

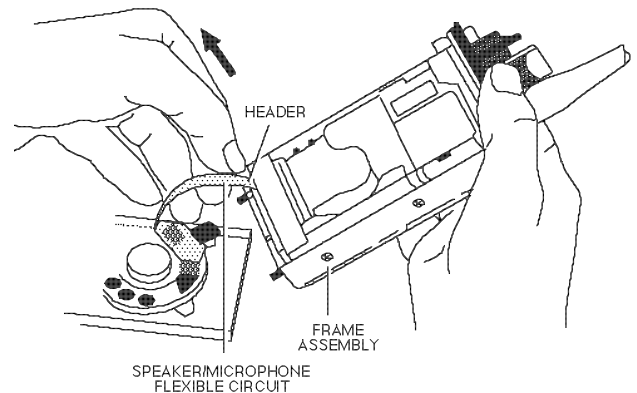

MAEPF-20615-A

### CAUTION

Refer to "SERVICING MAJOR SUBASSEMBLIES" (Section 2) and the appropriate exploded view diagrams at the back of this manual before attempting further disassembly or repair.

## 2. SERVICING MAJOR SUBASSEMBLIES

### a. Baseplate

- All repairs to the baseplate assembly can, and should, be made with the radio chassis inside the radio.
- After the slotted-spanner nuts are loosened, the baseplate is held in place by the power contact screw.
- The retainers holding the slotted-spanner nuts in place are not reusable. Replacement of the retainers requires special insertion procedures; refer to the instruction sheet provided with the slotted-spanner nut kit.
- The "o-ring" portion of the elastomer seal must be fully seated on the threaded bushing before the baseplate is reassembled (the bushing is part of the housing assembly).

### b. Housing Assembly

- The housing assembly includes many parts that are not replaceable or repairable.
- The insulator on the universal connector can, and should, be replaced if the old insulator has been torn. When replacing the insulator take care to keep it out of the main seal o-ring's seating area.
- The PTT lever can be replaced by prying out the old part with a soft plastic tool. The plastic housing around the lever may be damaged if a harder tool is used.

### c. Control Top Panel

- The control top panel is fastened to the frame by the on/off/volume and frequency switches, and two self-tapping screws; it should be removed from the frame only if absolutely necessary. If repair is required, always start the screws into the control top panel by hand before tightening them with a torque wrench; this will help avoid cross-threading and stripping of the plastic panel.
- The on/off/volume and frequency knobs are 2-part kits; each kit consists of a knob and an insert. Once an insert is removed, it cannot be used again; therefore, remove an insert only if the on/off/vol-

ume control or frequency switch must be replaced, or if the control top must be removed from the frame.

### d. LCD/Speaker Bracket Assembly

The SYSTEMS SABER radio's LCD assembly and/or controller board can be replaced, but the comments and cautions in this manual must be strictly followed.

#### (1) Removing the LCD Assembly and Controller Board:

- (a) Carefully unplug the interconnect and speaker/microphone flexible circuits from the radio.
- (b) (SYSTEMS SABER III only) After ensuring that all static safeguards are in effect, turn the LCD/speaker bracket assembly over (display facing up), insert a thin plastic blade (such as a tuning wand) between the top edge of the keypad membrane switch and the LCD bezel, and break the adhesive bond between the bezel and the membrane switch.
- (c) Turn the assembly over (front shield facing down) and, using a thin-bladed screwdriver, gently pry the controller board away from the two speaker bracket tabs (the tabs next to the speaker).
- (d) Place your middle finger on the top center tab and your thumb on the bottom left tab of the controller board, and gently pry the shield/controller board assembly away from the front shield.
- (e) Gently lift the shield/controller board assembly away from the front shield, rotating it around the front shield until the keypad flexible circuit lies flat and the display is facing upward.
- (f) Insert a thin-bladed screwdriver between the plug on the keypad flexible circuit and the controller board, and gently pry upward on the plug until it is free from the board.
- (g) With the controller board facing upward, locate the retaining tab on the top edge of the controller board and deflect the shield near the tab while lifting the board up and away from the shield. The circuit board and interconnect flexible circuit can then be pulled forward and out.

- (g) Unplug the interconnect flexible circuit from the controller board.
- (2) Replacing the LCD Assembly (SYSTEMS SABER III Only):
- (a) With the display facing downward, locate and carefully straighten the six bent-over metal tabs holding the LCD assembly to the controller board, then separate the LCD assembly from the board.
  - (b) Inspect the two rows of LCD contacts on the controller board for damage and/or foreign material, and clean if necessary.
  - (c) Using finger cots, inspect the new LCD assembly for fingerprints or other foreign material. Clean, if necessary, only with water-activated optical wipes.
  - (d) After first making sure that the lens shipping protection has been removed, insert the new LCD assembly so that the viewing side of the display shows through the window in the bezel, and the seal on the display fits into the corresponding recess in the bezel.
  - (e) Insert the LCD lightpipe into the bezel with the clear side facing the back of the display.
  - (f) Position the elastomers along the top and bottom edges of the LCD lightpipe so that the conductive black dots on the elastomers connect the LCD to the contacts on the controller board.
  - (g) Place the controller board over the metal tabs on the LCD bezel and, while applying firm, even pressure to fully seat the LCD assembly into the controller board, bend all the tabs inward.

**e. Backshield Assembly**

- Before removing the backshield, ensure that all static electricity safeguards are in place.
- For best results, loosen/tighten all four screws lightly before loosening/tightening any single screw completely.
- The backshield screws are held captive in the shield after being loosened.

**f. Circuit Boards and Modules**

- All modules plug into sockets on the main circuit



board.

- Some modules are fastened to the main board and frame with screws; remove these screws before attempting to unplug a module. **Never** substitute any screw.
- Several of the modules are designed to be removed with a standard DIP extractor tool (OK-1 or equivalent). Always use the extractor tool when removing these modules to avoid damaging their leads.
- Some modules have guide pins to assist in insertion or removal. Pressure may be applied to these guide pins to aid removal of a module if, and only if, it is distributed evenly over all guide pins on the module. *Applying all the force to a single guide pin will cause severe damage to the module.*
- The secure module (U900) is not serviceable.
- Before reinserting any module, always check its leads for damage. Gently straighten any leads that may be bent; replace any modules with severely damaged leads.

**CAUTION**

Inspect the frame stud seals and the top panel O-ring and replace if any damage exists.

Before reinserting reference oscillator module U301 into the main circuit board, be certain that its squared (pin 1) corner is correctly oriented per the main circuit board component layout diagram.

- When electrically testing and/or probing the main

**TORQUE SPECIFICATIONS**

APPLICATION	TORQUE (IN. LBS.)	TORQUE (N•m)	TORQUE BIT NO.
Antenna Bushing Spanner Nut	20	2.27	6680370B90
Back Shield to Frame Screws	2.5	0.28	6680321B79
Bottom Connector to Frame Screws	2.5	0.28	6680321B79
Frequency Switch Spanner Nut	8	0.91	6680370B88
All Module Screws	2.5	0.28	6680321B79
Power Contact Screws	2.5	0.28	6680321B79
Slotted-Spanner Nut (Baseplate)	6	0.68	6680370B89
Top Panel to Frame Screws	2	0.23	6680321B79
Volume Pot Spanner Nut	8	0.91	6680370B88

# PERFORMANCE TESTS

## 1. TEST MODE

When the SYSTEMS SABER radio is operating in a trunking environment, it operates with a specific identity within an assigned system. Given commands from that system, the radio's internal microcomputer controls such functions as rf channel selection, transmitter key-up, and receiver muting.

However, when the unit is on the bench for testing, it is removed from this trunking environment. It cannot receive commands from its system and, therefore, the internal microcomputer will not key the transmitter or unmute the receiver. This prevents testing the radio in the normal manner unless it has been programmed on one or more conventional (non-trunked) channels. On one of these channels the unit may be tested in the normal mode allowed by the channel's programmed modes; for example, tone Private-Line® (TPL), Digital Private-Line™ (DPL), etc.

To allow for testing the radio in a more generic fashion, special test routines that allow manual control of the various modes of the unit have been provided for in the test mode called Air Test, which allows one to test various parameters without having to disassemble the radio. If adjustments are needed, the use of the field programmer, described in the SYSTEMS SABER Radio Service Software User's Guide, will be required.

To enter the Air Test mode, connect the equipment as shown in Figure 1, then do the following:

- a. Turn the radio off.
- b. Apply 7.5 volts to the radio battery contacts.
- c. Connect the radio to the RTX4005B portable test set via the test cable.
- d. Place the transmit mode switch on the test set in the **CONT** (transmit) position.
- e. Press and hold down the monitor button on the side of the radio.
- f. Turn the radio on and continue to hold down the monitor button for two seconds.
- g. Turn the transmit mode switch on the test set to the **OFF** position.

### NOTE

- The unit will not transmit until the transmit mode switch has been turned off and then back to one of the transit positions.
- Do not change modes or channels during Air Test while in the transmit mode.
- To exit Air Test turn the radio off.

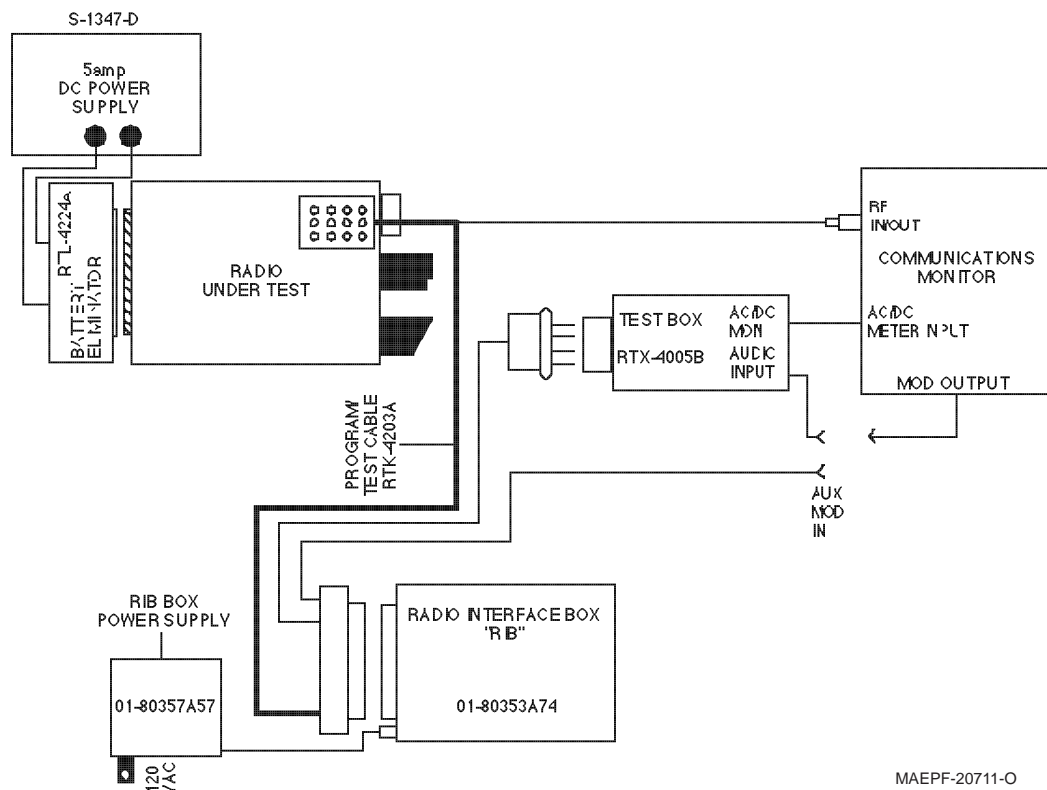

MAEPF-20711-O

Figure 1. Air Test Setup

Air Test allows the testing of any combination of ten frequency pairs, two transmitter power levels, six modulation modes, and three receiver squelch modes. Selection of a frequency pair is done by rotating the rotary selector switch on top of the radio. See Table 1 for a listing of the Air Test transmit and receiver frequencies, and transmitter power output levels associated with the rotary selector switch.

To change modulation/squelch modes, press one of the “side button” switches on the side of the radio: pressing the button closest to the *front* of the radio (SB1) will *increment* the mode; pressing the button closest to the *back* of the radio (SB2) will *decrement* the mode. See Table 2 for a listing on the various modulation/squelch modes.

As the modulation/squelch mode is changed, a one- to six-“bonk” audio tone will be heard, and the display will indicate the mode by displaying the squelch mode number from one to six.

**Table 1. Air Test**

Rotary Selector Switch Position	136-150.8 Model Freqs. (MHz)		146-162 Model Freqs. (MHz)		146-174 Model Freqs. (MHz)		148-174 Model Freqs. (MHz)		157-174 Model Freqs. (MHz)	
	Tx	Rx	Tx	Rx	Tx	Rx	Tx	Rx	Tx	Rx
1	136.05	143.55	146.05	152.25	146.05	160.25	148.05	160.25	157.05	163.25
2	139.05	136.25	149.05	146.25	149.05	146.25	149.05	146.25	160.05	157.25
3	142.05	150.75	152.05	161.85	152.05	173.85	152.05	173.85	163.05	173.85
4	145.05	145.05	155.15	155.15	155.15	155.15	155.15	155.15	166.15	166.15
5	148.05	148.05	158.05	158.05	158.05	158.05	158.05	158.05	169.05	169.05
6	150.75	150.75	161.95	161.85	161.05	173.85	161.05	173.85	171.05	173.85
7	150.75	150.75	161.95	161.85	164.05	173.85	164.05	173.85	173.95	173.85
8	150.75	150.75	161.95	161.85	168.05	173.85	168.05	173.85	173.95	173.85
9	150.75	150.75	161.95	161.85	171.05	173.85	171.05	173.85	173.95	173.85
10 thru 16	150.75	150.75	161.95	161.85	173.95	173.85	173.95	173.85	173.95	173.85

**Note:** The actual frequencies of the transmitter or receiver, and power-out setting of your unit may vary from the above table.

**Table 2. Modulation/Squelch Modes**

Mode	Audio Indication	Display Indication	Transmit Modulation Functions(s)	Receiver Squelch Function
1	1 bonk	Mode 1	Mic	RF Carrier Noise Squelch
2	2 bonks	Mode 2	Mic with PL	PL Squelched
3	3 bonks	Mode 3	Mic with Trunking Connect Tone	RF Carrier Squelch
4	4 bonks	Mode 4	Mic with DPL	DPL Squelch
5	5 bonks	Mode 5	High-Speed Trunking Data; 900 Hz Square Wave	RF Carrier Noise Squelch
6	6 bonks	Mode 6	MDC Encode Data, 1500 Hz Tone	RF Carrier Noise Squelch

## 2. PERFORMANCE CHECKS IN AIR TEST MODE

Tables 3 and 4 outline a series of performance checks that can be done without any disassembly of the radio. If there is an indication of a malfunction, these checks should be the first step in the fault isolation process. The FCC requires that the frequency and deviation of the transmitting device be checked before the device is placed in service and once annually thereafter.

When making measurements using field test equipment, allow for  $\pm 10\%$  measurement error. The SYSTEMS SABER radio is factory tuned using equipment of greater accuracy.

**Table 3. Transmitter Performance Checks in Air Test Mode**

### Transmitter Test:

All tests below are done with the test box PTT switch on; however, the switch *must be turned off when changing modes or channels*. All of the following tests can be performed on any frequency/channel. Set power supply to 7.5V at the radio battery terminals.

Set test box **METER SELECTOR** switch to the **MIC** position. Connect ac voltmeter to **AC/DC MONITOR** jack on

Test Name	Mode	Instructions	Specifications
Tx Power	1	Connect remote antenna port to power meter.	6W or 2.5W
Tx Current	1	Connect remote antenna port to 50 ohm load.	3.3 or 2.1 Amps
Tx Frequency Error	1	Measure Tx frequency at remote port.	$\pm 500\text{Hz}$ maximum
Tx Modulator Limiting	1	Audio input level = 80 mV rms; 1 kHz tone.	5 kHz maximum deviation
Tx Modulator Sensitivity	1	Apply 1 kHz tone. Adjust audio input level for 3.0 kHz deviation.	2-15 mV rms
Tx PL Deviation	2	Connect remote antenna port to deviation meter. Remove audio input.	0.5-1.0 kHz deviation
Tx Modulator Limiting with PL and Voice	2	Audio input level = 80 mV rms; 1 kHz tone.	5 kHz maximum deviation
Tx Connect Tone Deviation	3	Connect remote antenna port to deviation meter. Remove audio input.	0.8-1.2 kHz deviation
Tx Modulator Limiting with DPL and Voice	3	Audio input level = 80 mV rms; 1 kHz tone.	5 kHz maximum deviation
Tx DPL Deviation	4	Connect remote antenna port to deviation meter. Remove audio input.	0.5-1.0 kHz deviation
Tx Modulator Limiting with DPL and Voice	4	Audio input level = 80 mV rms 1 kHz tone.	5 kHz maximum deviation
Tx High Speed Data Deviation	5	Connect remote antenna port to deviation meter.	2.4-3.6 kHz deviation
Tx Binary Path	6	Special path not used at this time.	Not Applicable

**Table 4. Receiver Performance Checks in Air Test Mode**

**Receiver Test:**

1. In all of the following tests, the remote antenna port is connected to the rf signal generator.
2. The test box meter selector switch is set to “**AUDIO PA**”.
3. The test box speaker selector switch is set to “**A**”.
4. Connect the audio analyzer to the “**AC/DC MTR**” jack on the test box.
5. Set the power supply to 7.5 V at the radio battery terminals.
6. All of the following tests can be done on any frequency/channel.

Test Name	Mode	Instructions	Specifications
Rated Audio	1	Set rf generator output level to 1000 $\mu$ V (-47dBm). Set modulation to 1kHz tone @3kHz deviation. Set volume control for rated audio. Set audio analyzer to ac level.	3.7V rms audio out
Rx Audio Distortion	1	Set radio to rated audio. Set audio analyzer to check distortion.	5% maximum
Rx Current at Rated Audio	1	Set radio at rated audio.	235 mA maximum
Rx Sensitivity	1	Set radio to rated audio. Set audio analyzer to check SINAD. Decrease rf output of signal generator until 12dB SINAD is achieved. <b>Note:</b> In some cases it may be necessary to hold monitor button depressed to unsquelch radio.	0.35 $\mu$ V maximum (-116 dBm)
Rx Standby Current	2	Set rf signal generator output level to <-140dBm. Check that radio is squelched. Measure current.	105 mA maximum
Rx PL Squelch Sensitivity	2	Set rf signal generator level to <-140dBm. Modulate rf signal with 192.8 Hz tone at 750 Hz deviation. Check that the radio is squelched. Slowly increase rf signal level until radio becomes unsquelched.	0.5 $\mu$ V maximum (-113 dBm)
Rx DPL Squelch Sensitivity	4	Set rf signal generator output level to <-140dBm. Modulate rf signal with DPL code 131 at 750 Hz deviation. Check that the radio is squelched. Slowly	0.5 $\mu$ V maximum (-113dBm)