



MOTOROLA

MCS 2000 Mobile Radio Service Instructions

Volume 1

Non-Frequency Range Specific

Computer Software Copyrights

The Motorola products described in this manual may include copyrighted Motorola computer programs stored in semiconductor memories or other media. Laws in the United States and other countries preserve for Motorola certain exclusive rights for copyrighted computer programs, including the exclusive right to copy or reproduce in any form the copyrighted computer program. Accordingly, any copyrighted Motorola computer programs contained in the Motorola products described in this manual may not be copied or reproduced in any manner without the express written permission of Motorola. Furthermore, the purchase of Motorola products shall not be deemed to grant either directly or by implication, estoppel, or otherwise, any license under the copyrights, patents or patent applications of Motorola, except for the normal non-exclusive royalty free license to use that arises by operation of law in the sale of a product.

Notes, Cautions, Warnings, Danger

Throughout this guide, you will notice the use of NOTES, CAUTIONS, WARNINGS, and DANGERS. Their use is explained below.



NOTE: A clarifying statement that expands on the text that follows.



Caution

CAUTION indicates a potentially hazardous situation which, if not avoided, may result in equipment damage.



WARNING

WARNING indicates a potentially hazardous situation which, if not avoided, could result in death or injury.



DANGER indicates an imminently hazardous situation which, if not avoided, will result in death or serious injury.

Safety Information



WARNING

Every radio, when transmitting, radiates energy into the atmosphere which may, under certain conditions, cause the generation of a spark. All users of vehicles fitted with radios should be aware of the following warnings (see also “Important Electromagnetic Emission Information” below).

- Do not operate radio near flammable liquids or in the vicinity of explosive devices.

During normal use, the radio will subject you to radio energy substantially below the level where any kind of harm is reported. To ensure personal safety, please observe the following simple rules:

- Do not transmit when the antenna is very close to, or touching, exposed parts of the body, especially the face and eyes.
- Do not hold the transmit (PTT) key in when not desiring to transmit.
- Check the laws and regulations on the use of two-way mobile radios in the areas where you drive. Always obey them. Also, when using your phone while driving, please:
 - give full attention to driving,
 - use hands-free operation, if available, and
 - pull off the road and park before making or answering a call if driving conditions so require.

Airbag Warning



WARNING

An air bag inflates with great force. Do not place objects, including communication equipment, in the area over the air bag or in the air bag deployment area. If the communication equipment is improperly installed and the air bag inflates, this could cause serious injury.

Installation of vehicle communication equipment should be performed by a professional installer/ technician qualified in the requirements for such installations.

An air bag's size, shape and deployment area can vary by vehicle make, model and front compartment configuration (e.g., bench seat vs. bucket seats). Contact the vehicle manufacturer's corporate headquarters, if necessary, for specific air bag information for the vehicle make, model and front compartment configuration involved in your communication equipment installation.

Operational Safety Warnings



WARNING

For vehicles equipped with Electronic Ignition Systems, check the vehicle service manual for warnings about the use of two-way radio equipment in the vehicle.

The radio may switch into transmit mode, immediately upon being connected to power, if an open circuit exists between pins 4 and 9 of the Accessory Connector. To avoid personal injury and/or damage to the radio, ensure that a jumper wire or an emergency switch that has normally closed contacts is connected between pins 4 and 9 of the accessory connector before the radio is connected to vehicle battery power or any other power supply.

Radio Care / Handling Cautions

- Avoid physical abuse; do not pound, drop, or throw the radio. It may damage exposed parts such as controls and connectors.
- Do not connect accessories other than Motorola compatible equipment, as it may damage the radio. For a list of available compatible accessories consult the Mobius Accessories Guide part number 68P02058U52, or the MCS 2000 Accessories Guide part number 68P81080C47, or check with your local Motorola representative.
- The use of a Mini UHF Adaptor can damage the RF Antenna Connector and lead to radio failure, and is grounds for voiding warranty.
- Operating the radio without an antenna cable attached may lead to radio failure and is grounds for voiding warranty.

Important Electromagnetic Emission Information

In August, 1996, The Federal Communications Commission (FCC) adopted an updated safety standard for human exposure to radio frequency electromagnetic energy emitted by FCC regulated equipment. Motorola subscribes to this same updated safety standard for the use of its products.

In keeping with sound installation practice and to maximize radiation efficiency, a one-quarter (1/4) wave length antenna should be installed at the center of the vehicle roof. If it is necessary to mount the antenna on the vehicle's trunk lid, an appropriate 3db gain antenna should be used. This installation procedure will assure that vehicle occupants will be exposed to radio frequency energy levels lower than the limits specified in the standard adopted by the FCC in General Docket 79144.

To assure that radio frequency (RF) energy exposure to bystanders external to a vehicle is lower than that recommended by FCC adopted standard, transmit with any mobile radio only when bystanders are at least two (2) feet/60 cm away from a properly installed externally mounted antenna for radios with less than 50 watts of output power, or three (3) feet/90 cm away for radios with 50 watts or greater power.

Control Station Operation

In the event of Control Station operation, to assure operators and bystanders are exposed to radio frequency (RF) energy levels lower than the limits specified in the FCC adopted standard, the antenna should be installed outside of any building, but in no instance shall the antenna be within two feet/60 cm (less than 50 watts power output) or within three feet/90 cm (50 watts or higher power output) of station operators or bystanders.

LP Gas Warning



WARNING

It is mandatory that radios installed in vehicles fuelled by liquefied petroleum gas conform to the National Fire Protection Association standard NFPA 58, which applies to vehicles with a liquid propane (LP) gas container in the trunk or other sealed off space within the interior of the vehicle. The NFPA58 requires the following:

- Any space containing radio equipment shall be isolated by a seal from the space in which the LP gas container and its fittings are located.
- Removable (outside) filling connections shall be used.
- The container space shall be vented to the outside.

Anti-Lock Braking System (ABS) and Anti-Skid Braking System Precautions



WARNING

Disruption of the anti-skid/anti-lock braking system by the radio transmitter may result in unexpected vehicle motion.

Motorola recommends the following radio installation precautions and vehicle braking system test procedures to ensure that the radio, when transmitting, does not interfere with operation of the vehicle braking system.

Installation Precautions

Always provide as much distance as possible between braking modulator unit and radio, and between braking modulator unit and radio antenna and associated antenna transmission line. Before installing radio, determine location of braking modulator unit in vehicle. Depending on make and model of vehicle, braking modulator unit may be located in trunk, under dashboard, in engine compartment, or in some other cargo area. If you cannot determine location of braking modulator unit, refer to vehicle service manual or contact a dealer for the particular make of vehicle.

If braking modulator unit is located on left side of the vehicle, install radio on right side of vehicle, and conversely.

Route all radio wiring including antenna transmission line as far away as possible from braking modulator unit and associated braking system wiring.

Never activate radio transmitter while vehicle is in motion and vehicle trunk lid is open.

Braking System Tests

The following procedure checks for the most common types of interference that may be caused to vehicle braking system by a radio transmitter.

1. Run vehicle engine at idle speed and set vehicle transmission selector to PARK. Release brake pedal completely and key radio transmitter. Verify that there are no unusual effects (visual or audible) to vehicle lights or other electrical equipment and accessories while microphone is NOT being spoken into.
2. Repeat Step 1. except do so while microphone IS being spoken into.
3. Press vehicle brake pedal slightly just enough to light vehicle brake light(s). Then repeat Step 1. and Step 2.
4. Press the vehicle brake pedal firmly and repeat Step 1. and Step 2.
5. Ensure that there is a minimum of two vehicle lengths between front of vehicle and any object in vehicle's forward path. Then, set vehicle transmission selector to DRIVE. Press brake pedal just far enough to stop vehicle motion completely. Key radio transmitter. Verify that vehicle does not start to move while microphone is NOT being spoken into.
6. Repeat Step 5. except do so while microphone IS being spoken into.
7. Release brake pedal completely and accelerate vehicle to a speed between 15 and 25 miles/25 and 40 kilometers per hour. Ensure that a minimum of two vehicle lengths is maintained between front of vehicle and any object in vehicle's forward path. Have another person key radio transmitter and verify that vehicle can be braked normally to a moderate stop while microphone is NOT being spoken into.
8. Repeat Step 7. except do so while microphone IS being spoken into.
9. Release brake pedal completely and accelerate vehicle to a speed of 20 miles/30 kilometers per hour. Ensure that a minimum of two vehicle lengths is maintained between front of vehicle and any object in vehicle's forward path. Have another person key radio transmitter and verify that vehicle can be braked properly to a sudden (panic) stop while microphone is NOT being spoken into.
10. Repeat Step 9. except do so while microphone IS being spoken into.
11. Repeat Step 9. and Step 10. except use a vehicle speed of 30 miles/50 kilometers per hour.

Table of Contents

- 1 - Introduction 1-1
 - Scope of this Manual 1-1
 - Related Publications 1-1
 - Manual Revisions 1-1
 - Model Numbering System 1-2
 - List of Models 1-3
 - Kit-To-Model Structure 1-5
 - Specifications 1-6

- 2 - Basic Maintenance 2-1
 - Introduction 2-1
 - Preventive Maintenance 2-1
 - Inspection 2-1
 - Cleaning 2-1
 - Safe Handling of CMOS Devices 2-2
 - Precautions 2-2
 - Parts Replacement and Substitution 2-3
 - Rigid Circuit Boards 2-3
 - Specific 2-3
 - Audio PA Component Replacement Procedure 2-4
 - For High Power Models 2-4
 - Antenna/Power Connector Replacement Procedure 2-5
 - For Low, Mid, and High Power Models 2-5

- 3 - Test Equipment, Service Aids, and Tools 3-1
 - Recommended Test Equipment 3-1
 - Service Aids and Recommended Tools 3-2
 - Field Programming 3-2
 - Connection of Control Head Extender Cable 3-4
 - Mid Power Chassis 3-4
 - High Power Chassis 3-4

- 4 - Test Mode and Error Codes 4-1
 - Test Mode 4-1
 - General 4-1
 - Test Mode Features 4-1
 - Test Mode Entry and Exit 4-1
 - Error Code Displays 4-3
 - Power-up Display Codes 4-3
 - Operational Display Codes 4-4

- 5 - Disassembly & Reassembly and Replacement Procedures 5-1
 - General 5-1
 - Disassembly to Transceiver Board Level Low and Mid Power Models 5-1
 - Remove the Control Head 5-1
 - Remove Front Housing REMOTE MOUNT VERSION MODELS ONLY 5-2
 - Remove the Top Cover LOW POWER MODELS 5-2
 - MID POWER MODELS 5-2
 - Remove the Cavity Shield LOW POWER MODELS ONLY 5-3

Bootstrap Microprocessor Operation	7-16
Audio and Signalling Circuits	7-17
Audio Signalling Filter IC (ASFIC)	7-17
Audio Ground	7-17
Transmit Audio Circuits	7-17
Transmit Signalling Circuits	7-19
Receive Audio Circuits	7-21
Receive Signalling Circuits	7-25
8 - Control Heads	8-1
Model I	8-1
Introduction	8-1
Power supplies	8-1
Audio configuration	8-1
Volume Control/On-Off	8-1
Micro-controller	8-1
Xtal Oscillator	8-1
LCD	8-1
Keypad	8-2
Mode Select	8-2
Multiplexer Operation	8-2
Models II and III	8-3
Introduction	8-3
Power Supplies	8-3
Audio Configuration	8-3
Volume Control/On-Off	8-3
Micro-controller	8-4
Xtal Oscillator	8-4
LCD	8-4
Keypad	8-4
Rotary Switch	8-5
Mode Select	8-5
9 - Troubleshooting	9-1
Troubleshooting Chart 1-1, Overall Radio	9-2
Troubleshooting Chart 1-2 (1 of 3), Failure Codes	9-3
Troubleshooting Chart 1-2 (2 of 3), Failure Codes	9-4
Troubleshooting Chart 1-2 (3 of 3), Failure Codes	9-5
Troubleshooting Chart 1-3, On/Off Circuit	9-6
Troubleshooting Chart 1-4, TX Audio	9-7
TX Audio Routing, Simplified Schematic for Chart 1-4	9-7
Troubleshooting Chart 1-5, RX Audio	9-8
RX Audio Routing, Simplified Schematic for Chart 1-5	9-9
Troubleshooting Chart 1-6, Signalling	9-10
Troubleshooting Chart 1-7, DC Distribution	9-11
Radio Voltage, Simplified Schematic For Chart 1-7	9-12
Troubleshooting Chart 1-8A, Control Head Model I	9-13
Numbers in brackets refer to accompanying troubleshooting procedure overleaf	9-13
Control Head I Troubleshooting Procedure	9-14
Troubleshooting Chart 1-8B, Control Head Models II & III	9-18
Numbers in brackets refer to accompanying troubleshooting procedure overleaf	9-18
Control Heads II and III Troubleshooting Procedure	9-19
Troubleshooting Chart 1-9, Clock Distribution	9-24
Troubleshooting Chart 1-10, SB9600 BUS RX	9-25
Troubleshooting Chart 1-11, SB9600 BUS RX	9-26
SB9600 Voltage Table for Charts 1-10 & 1-11	9-26
SB9600 BUSY, Simplified Schematic for Charts 1-10 & 1-11	9-27

SB9600, Simplified Schematic for Charts 1-10 & 1-11	9-27
Troubleshooting Chart 1-12, GPIO	9-28
Troubleshooting Chart 1-13 (1 of 2), Power Control	9-29
Troubleshooting Chart 1-13 (2 of 2), Power Control	9-30
10 - Diagrams and Parts Lists	10-1
Notes on Sheet Port Connections, Circuit Block Port Connections and Physical Connectors	10-2
Schematic Hierarchy	10-2
Low Power Radios Exploded View Diagram and Parts List	10-4
Mid Power Radios Exploded View Diagram and Parts List	10-5
High Power Radios Exploded View Diagram and Parts List	10-6
Control Head Model I Exploded View Diagram and Parts List	10-7
Control Head Model II Exploded View Diagram and Parts List	10-8
Control Head Model III Exploded View Diagram and Parts List	10-9
Control Head Model I Component Locations and Parts List	10-10
Control Head Model I Schematic Diagram	10-11
Control Head Model II Component Locations and Parts List	10-12
Control Head Model II Schematic Diagram	10-13
Control Head Model III Component Locations and Parts List	10-14
Control Head Model III Schematic Diagram	10-15
Main Controller and Audio Power Amplifier and Voltage Regulators Component Locations	10-16
Controller Hierarchy Diagram	10-17
Main Controller Blocks Diagram	10-18
Controller, Microprocessor Schematic Diagram	10-19
Controller, Power Control Schematic Diagram	10-20
Controller, Audio Blocks Diagram	10-21
Controller, Hear Clear Schematic Diagram	10-22
Controller, ASFIC Schematic Diagram	10-23
Controller, Interface Blocks Diagram	10-24
Controller, IO RSSI Buffers Schematic Diagram	10-25
Controller, Emergency Ignition Schematic Diagram	10-26
Controller, SCI Drivers Schematic Diagram	10-27
Controller, IO Buffers Schematic Diagram	10-28
Controller, Audio Power Amplifier and Voltage Regulators, Low and Mid Power Schematic Diagram	10-29
Controller, Audio Power Amplifier and Voltage Regulators, High Power Schematic Diagram	10-30
Controller Parts List, Common Parts	10-31
Controller Parts List, Common Parts, Continued	10-33
Controller Parts List, 800 MHz 15W Unique	10-34
Controller Parts List, 800 MHz 35W Unique	10-35
Controller Parts List, 900 MHz 12W Unique	10-36
Controller Parts List, VHF 110W Unique	10-37
Controller Parts List, UHF1 110 W Unique	10-38
Controller Parts List, Non-Common Parts	10-39
Over Molded Pad Array Carriers (OMPACs)	10-40
Integrated Circuits with Pin-Out Names	10-40
A - Glossary of Terms	A-1

List of Figures

RF and Power Connector Openings	2-5
Install Connector Retaining Clip	2-5
Replace PA Board	2-5
Dedicated Test Mode Keys on Models I, II and III	4-2
Removing the Control Head	5-1
Removing the Top Cover - Low Power Models	5-2
Removing the Top Cover - Mid Power Models	5-3
Removing the Cavity Shield	5-3
Removing the PA Shield (Low and Mid Power Models)	5-4
Removing the Transceiver Board - Low Power Models (except 800 MHz and 900 MHz)	5-4
Removing the Transceiver Board - Mid Power Models (except 800 MHz and 900 MHz)	5-5
Removing the Transceiver Board (800 MHz and 900 MHz only)	5-6
Direction Conventions	5-7
Removing the Accessory Connector	5-7
Removing the Bottom Cover	5-8
Removing the RF Shield	5-8
Removing the PA Shield	5-9
Removing the PA Board	5-9
Removing the RF Board	5-10
Reassembly	5-14
Wakefield / Thermal Compound Application Area	5-16
Inserting Transceiver Board	5-16
Reassembly Screw Down Sequence	5-17
Inserting Audio PA Clip	5-18
Installing Cover Gasket	5-19
Model I Replaceable Pushbuttons	5-20
Model II Replaceable Pushbuttons	5-20
Model III Replaceable Pushbuttons	5-20
Grasping Pushbutton with Flat End Pliers	5-22
Pulling Pushbutton Away from Control Head	5-22
Radio Alignment Test Setup	6-1
Service Menu Structure for RVN4113	6-2
Softpot Concept	6-3
Clock Distribution Block Diagram	7-10
Transmit Audio Paths	7-18
Transmit Signalling Paths	7-20
Receive Audio Paths	7-22
Receive Signalling Paths	7-25
Troubleshooting Charts Overview	9-1
Schematic Diagram Hierarchy	10-2
Example of Transceiver Board Block Connection Diagram (110 Watt Radio)	10-3

List of Tables

Kit-to-Model Structure for VHF and UHF Radios	1-5
Kit-to-Model Structure for 800 and 900 MHz Radios	1-6
Recommended Test Equipment	3-1
Service Aids	3-2
Recommended Service Tools	3-3
Control Head Connector Pin Signals	3-4
Power Up Display Codes	4-4
Operational Display Codes	4-4
Replaceable Pushbutton Graphics and Part Numbers	5-23
Reference Oscillator Alignment	6-3
Transmit Power Setting	6-4
Current Limit Step Adjustment	6-5
Signaling Deviation	6-7
Conventional/MDC/SmartNet/SmartZone Ignition Sense Function - Operator Action vs Resultant Radio States	7-5
Secondary I/O Functions	7-12
Hear Clear Enable Lines Configuration	7-26

Introduction



Scope of this Manual

This manual includes model/kit information, specifications, fundamental disassembly/reassembly procedures, maintenance, alignment, troubleshooting; and all theory, schematic diagrams, printed circuit board details and parts lists for all Non-Frequency Range Specific parts in the equipment listed.

This manual is NOT a stand-alone manual, but requires the companionship of an appropriate Volume 2 manual in order to have all service information for a particular model of the radio. For every frequency band a band specific Volume 2 manual will be available.

By ordering the Complete Service Instructions, Motorola Publication Number 68P81080C40, you will receive Volume 1 as well as all Volume 2 band specific manuals available at the time of ordering. In addition, for radios that are equipped with the Motorola SECURENET option, the SECURENET Service manual, Motorola Publication Number 68P81083C25, is required.

Related Publications

- 68P02058U20: Installation Instructions covering mobile series 900 / 1200 / 2000 / 2100.
- 68P81080C40: MCS 2000 Mobile Radio Complete Service Instructions. All Frequency Ranges, includes all volume 2s.
- 68P81083C20: MCS 2000 Mobile Radio Service Instructions - Volume 1. Non-Frequency Range Specific (this publication).
- 68P81080C43: MCS 2000 Mobile Radio Service Instructions - Volume 2a. 800 MHz Frequency Range Specific.
- 68P81080C41: MCS 2000 Mobile Radio Service Instructions - Volume 2b. VHF Frequency Range Specific.
- 68P81080C42: MCS 2000 Mobile Radio Service Instructions - Volume 2c. UHF Frequency Range Specific.
- 68P81080C44: MCS 2000 Mobile Radio Service Instructions - Volume 2d. 900 MHz Frequency Range Specific.
- 68P81083C25: MCS 2000 Mobile Radio SECURENET Service Instructions.
- 68P81080C47: MCS 2000 Accessory Guide.
- 68P81080C35: MCS 2000 Mobile Radio Detailed User Reference Guide full operating instruction covering models I, II and III.
- 68P81080C05: MCS 2000 Short Form User Guide for Model I.
- 68P81080C10: MCS 2000 Short Form User Guide for Models II and III.
- 68P81077C65: FlashPort User's Guide.
- 68P81077C15: SmartZone RSS Manual.

Manual Revisions

Changes which occur after this manual is printed are described in Manual Revisions. These Manual Revisions provide complete information on changes including pertinent parts listing data.

Model Numbering System

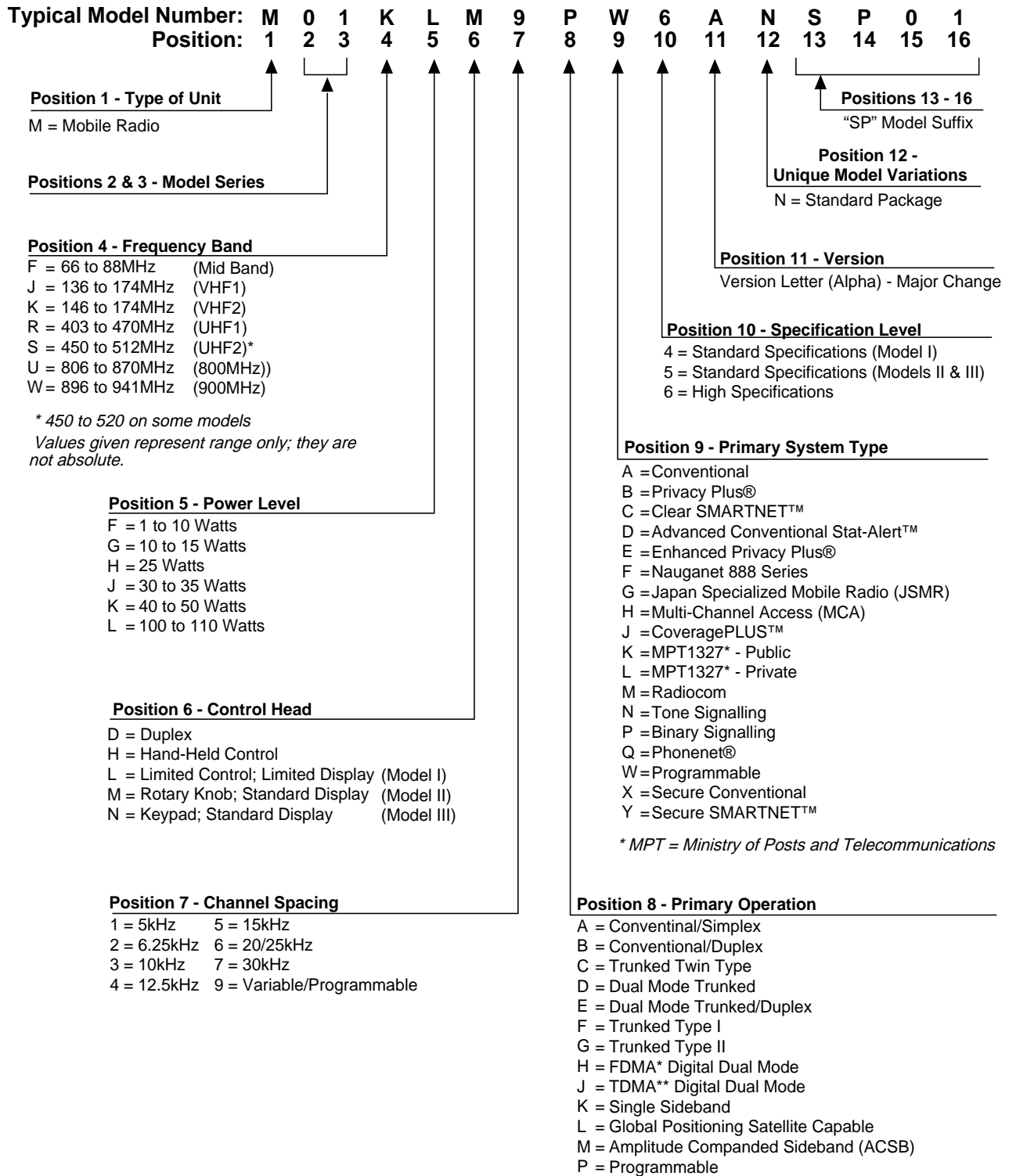

MEPC-95040-B/GB

* FDMA = Frequency Division Multiple Access
** TDMA = Time Division Multiple Access

List of Models

PRIVATE SYSTEMS RADIOS MCS 2000 Model Family					
Model Number	Frequency Range	Power Level	Control Head Model	Channel Spacing	No. of Modes
M01JLM9PW6_N	136 - 162 MHz	50-110 Watts	Model II, 1x14 digits	25/20/12.5 kHz	160
M01JLN9PW6A_N	136 - 162 MHz	50-110 Watts	Model III, 2x14 digits	25/20/12.5 kHz	160
M01JLH9PW6A_N	136 - 162 MHz	50-110 Watts	Hand-held Control Head	25/20/12.5 kHz	160
M01KHL9PW4_N	136 - 174 MHz	1-25 Watts	Model I, 8 digits	25/20/12.5 kHz	48
M01KHM9PW5_N	136 - 174 MHz	1-25 Watts	Model II, 1x14 digits	25/20/12.5 kHz	160
M01KHN9PW5_N	136 - 174 MHz	1-25 Watts	Model III, 2x14 digits	25/20/12.5 kHz	160
M01KHH9PW5_N	136 - 174 MHz	1-25 Watts	Hand-held Control Head	25/20/12.5 kHz	160
M01KKM9PW6_N	136 - 174 MHz	25-50 Watts	Model II, 1x14 digits	25/20/12.5 kHz	160
M01KKN9PW6_N	136 - 174 MHz	25-50 Watts	Model III, 2x14 digits	25/20/12.5 kHz	160
M01KKH9PW6_N	136 - 174 MHz	25-50 Watts	Hand-held Control Head	25/20/12.5 kHz	160
M01KLM9PW6_N	146 - 174 MHz	50-110 Watts	Model II, 1x14 digits	25/20/12.5 kHz	160
M01KLN9PW6_N	146 - 174 MHz	50-110 Watts	Model III, 2x14 digits	25/20/12.5 kHz	160
M01KLH9PW6_N	146 - 174 MHz	50-110 Watts	Hand-held Control Head	25/20/12.5 kHz	160
M01RFL9PW4_N	403 - 470 MHz	1-10 Watts	Model I, 8 digits	25/20/12.5 kHz	48
M01RFM9PW5_N	403 - 470 MHz	1-10 Watts	Model II, 1x14 digits	25/20/12.5 kHz	160
M01RFN9PW5_N	403 - 470 MHz	1-10 Watts	Model III, 2x14 digits	25/20/12.5 kHz	160
M01RFH9PW5_N	403 - 470 MHz	1-10 Watts	Hand-held Control Head	25/20/12.5 kHz	160
M01RHL9PW4_N	403 - 470 MHz	10-25 Watts	Model I, 8 digits	25/20/12.5 kHz	48
M01RHM9PW5_N	403 - 470 MHz	10-25 Watts	Model II, 1x14 digits	25/20/12.5 kHz	160
M01RHN9PW5_N	403 - 470 MHz	10-25 Watts	Model III, 2x14 digits	25/20/12.5 kHz	160
M01RHH9PW5_N	403 - 470 MHz	10-25 Watts	Hand-held Control Head	25/20/12.5 kHz	160
M01RKM9PW6_N	403 - 470 MHz*	25-50 Watts	Model II, 1x14 digits	25/20/12.5 kHz	160
M01RKN9PW6_N	403 - 470 MHz*	25-50 Watts	Model III, 2x14 digits	25/20/12.5 kHz	160
M01RKH9PW6_N	403 - 470 MHz*	25-50 Watts	Hand-held Control Head	25/20/12.5 kHz	160
M01RLM9PW6_N	403 - 470 MHz*	50-110 Watts	Model II, 1x14 digits	25/20/12.5 kHz	160
M01RLN9PW6_N	403 - 470 MHz*	50-110 Watts	Model III, 2x14 digits	25/20/12.5 kHz	160
M01RLH9PW6_N	403 - 470 MHz*	50-110 Watts	Hand-held Control Head	25/20/12.5 kHz	160
M01SHM9PW5_N	450 - 512 MHz	10-25 Watts	Model I, 8 digits	25/20/12.5 kHz	48
M01SHM9PW5_N	450 - 512 MHz	10-25 Watts	Model II, 1x14 digits	25/20/12.5 kHz	160
M01SHM9PW5_N	450 - 512 MHz	10-25 Watts	Model III, 2x14 digits	25/20/12.5 kHz	160
M01SLM9PW6_N	450 - 512 MHz	50-110 Watts	Model II, 1x14 digits	25/20/12.5 kHz	160
M01SLN9PW6_N	450 - 512 MHz	50-110 Watts	Model III, 2x14 digits	25/20/12.5 kHz	160
M01SLH9PW6_N	450 - 512 MHz	50-110 Watts	Hand-held Control Head	25/20/12.5 kHz	160
M01UGL6PW4_N	806 - 870 MHz	15 Watts	Model I, 8 digits	20/25 kHz	48
M01UGM6PW5_N	806 - 870 MHz	15 Watts	Model II, 1x14 digits	20/25 kHz	160
M01UGM6PW6_N	806 - 870 MHz	15 Watts	Model II, 1x14 digits	20/25 kHz	160

**PRIVATE SYSTEMS RADIOS
MCS 2000 Model Family**

Model Number	Frequency Range	Power Level	Control Head Model	Channel Spacing	No. of Modes
M01UGN6PW6_N	806 - 870 MHz	15 Watts	Model III, 2X14 digits	20/25 kHz	160
M01UGH6PW6_N	806 - 870 MHz	15 Watts	Hand-held Control Head	20/25 kHz	160
M01UJL6PW4_N	806 - 870 MHz	30-35 Watts	Model I, 8 digits	20/25 kHz	48
M01UJM6PW6_N	806 - 870 MHz	30-35 Watts	Model II, 1x14 digits	20/25 kHz	160
M01UJN6PW6_N	806 - 870 MHz	30-35 Watts	Model III, 2X14 digits	20/25 kHz	160
M01UJH6PW6_N	806 - 870 MHz	30-35 Watts	Hand-held Control Head	20/25 kHz	160
M01WGL4PW4_N	896-941 MHz	12 Watts	Model I, 8 digits	12.5 kHz	48
M01WGM4PW6_N	896-941 MHz	12 Watts	Model II, 1x14 digits	12.5 kHz	160
M01WGN4PW6_N	896-941 MHz	12 Watts	Model III, 2X14 digits	12.5 kHz	160
M01WGH4PW6_N	896-941 MHz	12 Watts	Hand-held Control Head	12.5 kHz	160
M01WJL4PW4_N	896-941 MHz	30 Watts	Model I, 8 digits	12.5 kHz	48
M01WJM4PW6_N	896-941 MHz	30 Watts	Model II, 1x14 digits	12.5 kHz	160
M01WJN4PW6_N	896-941 MHz	30 Watts	Model III, 2X14 digits	12.5 kHz	160
M01WJH4PW6_N	896-941 MHz	30 Watts	Hand-held Control Head	12.5 kHz	160

* The radio will operate with some degradation in receiver performance in 433-438 MHz frequencies.

Kit-To-Model Structure

The cross-reference charts below show the kit breakdown for each of the MCS 2000 models. Table 1-1 covers the VHF and UHF models and Table 1-2 covers the 800 MHz and 900 MHz models.

Table 1-1 Kit-to-Model Structure for VHF and UHF Radios

Item	Description											Model	Description
HUD4012D	RF/Ctrl Bd, VHF, 1-25W											M01KHM9PW5_N	VHF1, 25W, Mod. II
HUD4006A	RF/Ctrl Bd, VHF, 25-50W											M01KHN9PW5_N	VHF1, 25W, Mod. III
HUD4015A	RF/Ctrl Bd, VHF1/VHF2, 110W											M01KHH9PW5_N	VHF1, 25W, Hand held
HUD4021A	PA VHF1, 110W											M01KKM9PW6_N	VHF1, 50W, Mod. II
HUD4016A	PA VHF2, 110W											M01KKN9PW6_N	VHF1, 50W, Mod. III
HUE4021B	RF/Ctrl Bd, UHF1, 1-10W											M01KKH9PW6_N	VHF1, 50W, Hand held
HUE4012C1	RF/Ctrl Bd, UHF1, 10-25W											M01JLM9PW6_N	VHF1, 110W, Mod. II
HUE4011B2	RF/Ctrl Bd, UHF2, 10-25W											M01JLN9PW6_N	VHF1, 110W, Mod. III
HUE4020A	PA, UHF2, 110W											M01JLH9PW6_N	VHF1, 110W, Hand held
HUE4019A	RF/Ctrl Bd, UHF2, 110W											M01KLM9PW6_N	VHF2, 110W, Mod. II
NLE4248A	RF/Ctrl Bd, UHF, 50 W											M01KLN9PW6_N	VHF2, 110W, Mod. III
HUE4018A	PA, UHF, 110W											M01KLH9PW6_N	VHF2, 110W, Hand held
HUE4017A	RF/Ctrl Bd, UHF, 110W											M01RFM9PW5_N	UHF1, 10W, Mod. II
HCN1092B	Ctrl Hd II											M01RFN9PW5_N	UHF1, 10W, Mod. III
HCN1091B	Ctrl Hd I											M01RFH9PW5_N	UHF1, 10W, Hand held
HCN1093B	Ctrl Hd III											M01RHL9PW4_N	UHF1, 10-25W, Mod. I
HLN6544A	Housing, LP (≥25W), VHF/UHF											M01RHM9PW5_N	UHF1, 10-25W, Mod. II
HHN4041A	Housing, MP (25-50W)											M01RHN9PW5_N	UHF1, 10-25W, Mod. III
HHN4042A	Housing, HP (110W)											M01RHH9PW5_N	UHF1, 10-25W, Hand
HLN6354A	Trstr Hw kit V/U 25W											M01RKM9PW6_N	UHF1, 50W, Mod. II
HLN6357A	Trstr Hw kit VHF 50W											M01KHN9PW6_N	UHF1, 50W, Mod. III
HLN6572A	Trstr Hw kit VHF 100W											M01RKH9PW6_N	UHF1, 50W, Hand held
HLN6353A	Trstr Hw kit U2 25W											M01RLM9PW6_N	UHF1, 110W, Mod. II
												M01RLN9PW6_N	UHF1, 110W, Mod. III
												M01RLH9PW6_N	UHF1, 110W, Hand held
												M01SHM9PW5_N	UHF2, 25W, Mod. II
												M01SLM9PW5_N	UHF2, 110W, Mod. II
												M01SLN9PW5_N	UHF2, 110W, Mod. III
												M01SLH9PW5_N	UHF2, 110W, Hand held

SPECIFICATIONS FOR VHF, 1-25 WATT RADIOS

All specifications are per **European Telecommunication Standard (ETS) 300-086** unless otherwise noted.

GENERAL	RECEIVER	TRANSMITTER
<p>Temperature Range: Operating: -25 to +55°C Storage: -40 to +85°C</p> <p>Power Supply: Nominal Voltage: 13.6 V Operating Voltage: 10.8-15.6 V Current Drain, maximum values: Stand-by: 0.45 A Receive: 1.7 A with 7.5 W speaker 2.5 A with 13 W speaker 1.5 A with 4 W speaker Transmit: 8.75 A Off 35 mA</p> <p>Number of Modes: Model I: Standard 48, optional 150 Model II, III: Standard 160, optional 250</p> <p>Channel Spacing: 12.5, 20, 25 kHz</p> <p>Mode of Operation: Simplex/Half-Duplex</p> <p>Modulation: FM/PM</p> <p>Antenna Impedance: 50 Ω</p> <p>Frequency Stability: ±5.0 ppm</p> <p>Dimensions (H/W/D): 1-25 Watt Transceiver: 44x168x180 mm / 1.73"x6.61"x7.09" Control Head I, Dash Mt.: 44x168x30 mm / 1.73"x6.61"x1.18" Control Head II, III, Dash Mt.: 60x190x30 mm / 2.36"x7.48"x1.18" Control Head II, III, Remote Mt.: 60x190x71 mm / 2.36"x7.48"x2.80"</p> <p>Weight: 1-25 Watt Transceivers: 1.6 kg / 3.53 lbs Control Head I, Dash Mt.: 152 g / 0.33 lbs Control Head II, Dash Mt.: 233 g / 0.51 lbs Control Head III, Dash Mt.: 229 g / 0.50 lbs</p>	<p>Frequency Range: 136-174MHz</p> <p>Maximum Frequency Separation: 38 MHz</p> <p>Sensitivity: 20dB SINAD: 12.5 kHz: 0.45 uV 20/25 kHz: 0.35 uV 12dB SINAD: 0.30 uV</p> <p>Adjacent Channel Selectivity: 12.5 kHz: >70 dB 20 kHz: >75 dB 25 kHz: >80 dB</p> <p>Spurious / Image Rejection: >80 dB</p> <p>Intermodulation: (uVemf)>70 dB</p> <p>Conducted Spurious Emission: <2 nW</p> <p>Audio Output: 12.5 kHz: 4 W (internal, 16 Ω) 20/25 kHz: 7.5/13 W (external, 8 Ω/3.2 Ω)</p> <p>Audio Response: 6 dB/octave +1/-3 dB at 300-3000 Hz</p> <p>Distortion: EIA: <3% CEPT: <5%</p>	<p>Frequency Range: 136-174MHz</p> <p>RF Power: 1 - 25 Watts variable</p> <p>Deviation, Maximum: 12.5 kHz channel spacing: ±2.5 kHz 20 kHz channel spacing: ±4.0 kHz 25 kHz channel spacing: ±5.0 kHz</p> <p>Spurious & Harmonics: <0.25 uW</p> <p>Audio Response: 6 dB/octave +1/-3 dB at 300-3000 Hz</p> <p>Distortion: <3% @ 60% of maximum deviation</p> <p>Adjacent Channel Power (CEPT): 12.5 kHz: <60 dB 20/25 kHz: <-70 dB</p>

Specifications subject to change without notice.

SPECIFICATIONS FOR UHF, 1-10 WATT AND 10-25 WATT RADIOS

All specifications are per **European Telecommunication Standard (ETS) 300-086** unless otherwise noted.

GENERAL	RECEIVER	TRANSMITTER
Temperature Range: Operating: -25 to +55°C Storage: -40 to +85°C Power Supply: Nominal Voltage: 13.6 V Operating Voltage: 10.8-15.6 V Current Drain, maximum values: Stand-by: 0.45 A Receive: 1.7 A with 7.5 W speaker 2.5 A with 13 W speaker 1.5 A with 4 W speaker Transmit (25W): 8.75 A Off: 35 mA Number of Modes: Model I: Standard 48, optional 150 Model II, III: Standard 160, optional 250 Channel Spacing: 12.5, 20, 25 kHz Mode of Operation: Simplex/Half-Duplex Modulation: FM/PM Antenna Impedance: 50 Ω Frequency Stability: ±4.0 ppm Dimensions (H/W/D): 1-25 Watt Transceiver: 44x168x180 mm / 1.73"x6.61"x7.09" Control Head I, Dash Mt.: 44x168x30 mm / 1.73"x6.61"x1.18" Control Head II, III, Dash Mt.: 60x190x30 mm / 2.36"x7.48"x1.18" Control Head II, III, Remote Mt.: 60x190x71 mm / 2.36"x7.48"x2.80" Weight: 1-25 Watt Transceivers: 1.6 kg / 3.53 lbs Control Head I, Dash Mt.: 152 g / 0.33 lbs Control Head II, Dash Mt.: 233 g / 0.51 lbs Control Head III, Dash Mt.: 229 g / 0.50 lbs	Frequency Range: 403-470 MHz Maximum Frequency Separation: 67 MHz Sensitivity: 20dB SINAD: 12.5 kHz: 0.45 uV 20/25 kHz: 0.35 uV 12dB SINAD: 12.5 kHz: 0.35 uV 20/25 kHz: 0.30 uV Adjacent Channel Selectivity: 12.5 kHz: >65 dB 20 kHz: >70 dB 25 kHz: >75 dB Spurious / Image Rejection: >80 dB Intermodulation: (uVemf)>70 dB Conducted Spurious Emission: <2 nW Audio Output: 12.5 kHz: 4 W (internal, 16 Ω) 20/25 kHz: 7.5/13 W (external, 8 Ω/3.2 Ω) Audio Response: 6 dB/octave +1/-3 dB at 300-3000 Hz Distortion: EIA: <3% CEPT: <5%	Frequency Range: 403-470 MHz RF Power: 1 - 10 Watts variable 10-25 Watts variable Deviation, Maximum: 12.5 kHz channel spacing: ±2.5 kHz 20 kHz channel spacing: ±4.0 kHz 25 kHz channel spacing: ±5.0 kHz Spurious & Harmonics: <0.25 uW Audio Response: 6 dB/octave +1/-3 dB at 300-3000 Hz Distortion: <3% @ 60% of maximum deviation Adjacent Channel Power (CEPT): 12.5 kHz: <60 dB 20/25 kHz: <-70 dB

Specifications subject to change without notice.

SPECIFICATIONS FOR 800 MHZ, 15 WATT AND 30-35 WATT RADIOS

All specifications are per Electronic Industries Association (EIA) 603 unless otherwise noted.

GENERAL	RECEIVER	TRANSMITTER
<p>FCC Designation: 30-35W: AZ492FT5773 15W: AZ492FT5765</p> <p>Temperature Range: Operating: -30 to +60°C Storage: -40 to +85°C</p> <p>Power Supply: Nominal Voltage: 13.6 V Operating Voltage: 10.8-16.3 V Current Drain, maximum values: Stand-by: 0.45 A Receive: 1.7 A with 7.5 W speaker 2.5 A with 13 W speaker 1.5 A with 4 W speaker Transmit (15W): 6.5 A Transmit (35W): 13.5 A Off: 30 mA</p> <p>Number of Modes: Model I: Standard 48, optional 150 Model II, III: Standard 160, optional 250</p> <p>Channel Spacing: 806-821 & 851-866MHz: 25 kHz 821-825 & 866-870MHz: 20 kHz</p> <p>Mode of Operation: Semi-Duplex</p> <p>Modulation: FM</p> <p>Antenna Impedance: 50 Ω</p> <p>Frequency Stability: 806-821 MHz & 851-866 MHz: ±2.5 ppm 821-825 MHz & 866-870 MHz: ±1.5 ppm</p> <p>Dimensions (H/W/D): 1-25W Transceivers: 44x168x180 mm / 1.73"x6.61"x7.09" 25-50W Transceivers: 44x168x230 mm / 1.97"x6.61"x7.76" Control Head I, Dash Mt.: 44x168x30 mm / 1.75"x6.61"x1.81" Control Head II, III, Dash Mt.: 60x186x30 mm / 2.35"x7.33"x1.83" Control Head II, III, Remote Mt.: 60x186x71 mm / 2.35"x7.33"x2.78"</p> <p>Weight: 1-25 Watt Transceivers: 1.6 kg / 3.53 lbs 25-50 Watt Transceivers: 1.8 kg / 4.04 lbs Control Head I, Dash Mt.: 152 g / 0.33 lbs Control Head II, Dash Mt.: 233 g / 0.51 lbs Control Head III, Dash Mt.: 229 g / 0.50 lbs</p>	<p>Frequency Range: 851-866MHz 866-870MHz</p> <p>Maximum Frequency Separation: 18 MHz</p> <p>Sensitivity: 20dB SINAD: 0.40 uV 12dB SINAD: 0.30 uV</p> <p>Adjacent Channel Selectivity: Model I: -75 dB Models II & III: -80 dB</p> <p>Spurious & Image Rejection: Model I: -75 dB Models II & III: -90 dB</p> <p>Intermodulation: (uVemf) Model I: -75 dB Models II & III: -80 dB</p> <p>Conducted Spurious Emission: per FCC part 90</p> <p>Audio Output: 4 W (internal, 16 Ω) 7.5 W or 13 W (external, 8 Ω/3.2 Ω)</p> <p>Audio Response: 6 dB/octave +1/-3 dB at 300-3000 Hz</p> <p>Distortion: 4/7.5/13 W @:-5%</p>	<p>Frequency Range: 806-821 & 821-825MHz (Talkaround) 851-866 & 866-870MHz</p> <p>Maximum Frequency Separation: 63 MHz</p> <p>RF Power: 15 Watts 30 or 35 Watts</p> <p>Deviation, Maximum: @ 806-821 & 851-866MHz: 5 kHz @ 821-825 & 866-870MHz: 4 kHz</p> <p>Spurious & Harmonics: -70 dBc</p> <p>Audio Response: 6 dB/octave +1/-3 dB at 300-3000 Hz</p> <p>Distortion: <3% @ 60% of maximum deviation</p> <p>Adjacent Channel Power (CEPT): >-60 dBc</p>

Specifications subject to change without notice.

SPECIFICATIONS FOR 900 MHZ, 12 WATT AND 30 WATT RADIOS

All specifications are per Electronic Industries Association (EIA) 603 unless otherwise noted.

GENERAL	RECEIVER	TRANSMITTER
<p>FCC Designation: 30W: AZ492FT5773 12W: AZ492FT5765</p> <p>Temperature Range: Operating: -30 to +60°C Storage: -40 to +85°C</p> <p>Power Supply: Nominal Voltage: 13.6 V Operating Voltage: 10.8-16.3 V Current Drain, maximum values: Stand-by: 0.45 A Receive: 1.7 A with 7.5 W speaker 2.5 A with 13 W speaker 1.5 A with 4 W speaker Transmit (12W): 6.5 A Transmit (30W): 14.5 A Off: 30 mA</p> <p>Number of Modes: Model I: Standard 48, optional 150 Model II, III: Standard 160, optional 250</p> <p>Channel Spacing: 12.5 kHz</p> <p>Mode of Operation: Semi-Duplex</p> <p>Modulation: FM</p> <p>Antenna Impedance: 50 Ω</p> <p>Frequency Stability: ±1.5 ppm</p> <p>Dimensions (H/W/D): 1-25W Transceivers: 44x168x180 mm / 1.73"x6.61"x7.09" 25-50W Transceivers: 44x168x230 mm / 1.97"x6.61"x7.76" Control Head I, Dash Mt.: 44x168x30 mm / 1.75"x6.61"x1.81" Control Head II, III, Dash Mt.: 60x186x30 mm / 2.35"x7.33"x1.83" Control Head II, III, Remote Mt.: 60x186x71 mm / 2.35"x7.33"x2.78"</p> <p>Weight: 1-25 Watt Transceivers: 1.6 kg / 3.53 lbs 25-50 Watt Transceivers: 1.8 kg / 4.04 lbs Control Head I, Dash Mt.: 152 g / 0.33 lbs Control Head II, Dash Mt.: 233 g / 0.51 lbs Control Head III, Dash Mt.: 229 g / 0.50 lbs</p>	<p>Frequency Range: 896-941MHz</p> <p>Maximum Frequency Separation: 6 MHz</p> <p>Sensitivity: 20dB SINAD: 0.40 uV 12dB SINAD: 0.30 uV</p> <p>Adjacent Channel Selectivity: Model I: -65 dB Models II & III: -70 dB</p> <p>Spurious & Image Rejection: Model I: -70 dB Models II & III: -90 dB</p> <p>Intermodulation: (uVemf) Model I: -65 dB Models II & III: -70 dB</p> <p>Conducted Spurious Emission: per FCC part 90</p> <p>Audio Output: 4 W (internal, 16 Ω) 7.5 W or 13 W (external, 8 Ω/3.2 Ω)</p> <p>Audio Response: 6 dB/octave +1/-3 dB at 300-3000 Hz</p> <p>Distortion: 4/7.5/13 W @:<5%</p>	<p>Frequency Range: 896-941MHz</p> <p>Maximum Frequency Separation: 45 MHz</p> <p>RF Power: 12 Watts 30 Watts</p> <p>Deviation, Maximum: 2.5 kHz</p> <p>Spurious & Harmonics: -70 dBc</p> <p>Audio Response: 6 dB/octave +1/-3 dB at 300-3000 Hz</p> <p>Distortion: <3% @ 60% of maximum deviation</p> <p>Adjacent Channel Power (CEPT): >-60 dBc</p>

Specifications subject to change without notice.

Basic Maintenance



Introduction This chapter of the manual describes preventive maintenance, safe handling of CMOS devices, and repair procedures and techniques. Each of these topics provides information vital to the successful operation and maintenance of your radio.

Preventive Maintenance The radios do not require a scheduled preventive maintenance program; however, periodic visual inspection and cleaning is recommended.

Inspection Check that the external surfaces of the radio are clean, and that all external controls and switches are functional. A detailed inspection of the interior electronic circuitry is not needed or desired.

Cleaning The following procedures describe the recommended cleaning agents and the methods to be used when cleaning the external and internal surfaces of the radio. External surfaces include the front cover, housing and assembly. These surfaces should be cleaned whenever a periodic visual inspection reveals the presence of smudges, grease, and/or grime. Internal surfaces should be cleaned only when the radio is disassembled for servicing or repair.

The only recommended agent for cleaning the external radio surfaces is a 0.5% solution of a mild dishwashing detergent in water. The only factory recommended liquid for cleaning the printed circuit boards and their components is isopropyl alcohol (70% by volume).



The effects of certain chemicals and their vapors can have harmful results on certain plastics. Aerosol sprays, tuner cleaners, and other chemicals should be avoided.

Plastic Surfaces The detergent-water solution should be applied sparingly with a stiff, nonmetallic, short-bristled brush to work all loose dirt away from the radio. A soft, absorbent, lint-free cloth or tissue should be used to remove the solution and dry the radio. Make sure that no water remains entrapped near the connectors, cracks, or crevices.

Circuit Boards and Components Isopropyl alcohol may be applied with a stiff, nonmetallic, short-bristled brush to dislodge embedded or caked materials located in hard-to-reach areas. The brush stroke should direct the dislodged material out and away from the inside of the radio.

Alcohol is a high-wetting liquid and can carry contamination into unwanted places if an excessive quantity is used. Make sure that controls or tuneable components are not soaked with the liquid. Do not use high-pressure air to hasten the drying process, since this could cause the liquid to puddle and collect in unwanted places.

Upon completion of the cleaning process, use a soft, absorbent, lint-free cloth to dry the area. Do not brush or apply any isopropyl alcohol to the frame, front cover, or back cover.



Always use a fresh supply of alcohol and a clean container to prevent contamination by dissolved material (from previous usage).

Safe Handling of CMOS Devices



Complementary metal-oxide semiconductor (CMOS) devices are used in this family of radios. While the attributes of CMOS are many, their characteristics make them susceptible to damage by electrostatic or high voltage charges. Damage can be latent, resulting in failures occurring weeks or months later. Therefore, special precautions must be taken to prevent device damage during disassembly, troubleshooting, and repair. Handling precautions are mandatory for CMOS circuits, and are especially important in low humidity conditions. DO NOT attempt to disassemble the radio without observing the following handling precautions.

Precautions

12. Eliminate static generators (plastics, styrofoam, etc.) in the work area.
13. Remove nylon or double-knit polyester jackets, roll up long sleeves, and remove or tie back loose hanging neckties
14. Store and transport all static-sensitive devices in ESD-protective containers.
15. If at all possible, handle CMOS devices by the package and not by the leads. Prior to touching the unit, touch an electrical ground to remove any static charge that you may have accumulated. The package and substrate may be electrically common. If so, the reaction of a discharge to the case would cause the same damage as touching the leads.
16. Disconnect all power from the unit before ESD-sensitive components are removed or inserted unless otherwise noted.
17. Use a static-safeguarded workstation, which can be accomplished through the use of an anti-static kit (Motorola part number 01-80386A82). This kit includes a wrist strap, two ground cords, a static-control table mat and a static-control floor mat. For additional information, refer to Service and Repair Note SRN F1052, "Static Control Equipment for Servicing ESD Sensitive Products", available from Motorola Literature Distribution 2290 Hammond Drive Schaumburg, IL 60173 (847) 576-2826

When these items are not readily available, observing the following techniques will minimize chance of damage.

- If a static-sensitive device is to be temporarily set down, use a conductive surface for placement of the device.
- Make skin contact with a conductive work surface first and maintain this contact when the device is set down or picked up.

18. Always wear a conductive wrist strap when servicing this equipment. The Motorola part number for a replacement wrist strap that connects to the table mat is 42-80385A59.
19. When straightening CMOS pins, provide ground straps for apparatus used.
20. When soldering, use a grounded soldering iron.

Parts Replacement and Substitution

Special care should be taken to be as certain as possible that a suspected component is actually the one at fault. This special care will eliminate unnecessary unsoldering and removal of parts, which could damage or weaken other components or the printed circuit board itself.

When damaged parts are replaced, identical parts should be used. If the identical replacement component is not locally available, check the parts list for the proper Motorola part number and order the component from the nearest Motorola Communications Parts office.

Rigid Circuit Boards

This family of radios uses bonded, multi-layer, printed circuit boards. Since the inner layers are not accessible, some special considerations are required when soldering and unsoldering components. The printed-through holes may interconnect multiple layers of the printed circuit. Therefore, care should be exercised to avoid pulling the plated circuit out of the hole.

When soldering near the module socket pins, use care to avoid accidentally getting solder in the socket. Also, be careful not to form solder bridges between the module socket pins. Closely examine your work for shorts due to solder bridges. When removing modules with metal enclosures, be sure to desolder the enclosure ground tabs as well as the module pins.

Specific

During all repair procedures, heating neighbouring components can be minimized by:

- using upper heat only.
- using the correct size heat focus head approximately the same size as the carrier being replaced
- keeping the heat focus head approximately 1/8" or 3-6 mm above the printed circuit board when removing or replacing the device.



Caution

If neighbouring OMPAC components are heated above 365 degrees F or 185 degrees C they will suffer die-bond delamination and possible "popcorn" failure.

Audio PA Component Replacement Procedure

For High Power Models



Caution

This procedure must be used when replacing these components to ensure proper alignment and heatsinking.

1. Remove the main board from the chassis per disassembly instructions in Chapter 5.
2. Remove the faulty component in the Audio PA section of the main board. Ensure that the through-holes are free of solder.
3. Place the main board in a chassis eliminator (Motorola Part Number 2705815W03). Assemble the screws based on the Screw-Down sequence in Figure 5-19.
4. Place new component(s) in the proper location. Assemble the Audio PA Clip per the reassembly instructions Step 8. on page 5-22.
5. Flip the chassis eliminator over.
6. Using a large tip soldering iron set to 750°F max, heat ground plane around through holes for approximately 15 seconds. Dispense 6337 Tin Lead solder wire until a uniform solder fillet exists. Repeat this operation for all leads.
7. Inspect solder joints. There should be a uniform fillet. The joints should be shiny and not dull in appearance.
8. Remove the Audio PA clip per disassembly instructions Step 2. on page 5-14. Remove all screws. Pull board out of chassis eliminator.

Antenna/Power Connector Replacement Procedure

For Low, Mid, and High Power Models

Note that Figures show High Power Chassis, but apply to all power levels.

1. Remove damaged connector by heating the solder joints until they reflow. Pull connector from board with small pliers or like instrument.
2. Place new connector (either Power or RF) in opening in chassis (See Figure 2-1.). Connector Part Numbers can be found in Chapter 10.
3. Install connector retaining clip over connector and chassis wall (See Figure 2-2.).
4. Install PA Board, aligning connector holes over connector pins per orientation in Figure 2-3. Ensure that the undamaged connector has a retaining clip installed.
5. Screw down board using Torx drivers per the Assembly Section of Chapter 5. For High Power radios, follow the screw-down sequence found in Figure 5-19.
6. Using a large tip soldering iron set to maximum 750°F/400°C, heat ground leads on connector for approximately 15 seconds. Dispense 6337 Tin Lead solder wire until a uniform solder fillet exists.



Caution

Using temperatures higher than 750°F/400°C will cause the modular ground rings to pull off the board around pins and cause the board irreparable damage.

7. Inspect solder joints. The solder should not “ball-up” over leads. There should be a uniform fillet. The joints should be shiny and not dull in appearance.



Caution

If solder joint does not exhibit these characteristics, the joint will contain a cold solder and/or voids that could damage the Power Amplifier portion of the radio.

8. Remove retaining clips. Unscrew board. Take board out of chassis.
9. Inspect for uniform solder fillet around leads on heavy side of board. Ensure that there is not excessive solder around leads. If excessive solder exists, carefully remove it with the soldering iron.
10. Reassemble board into chassis per the Reassembly/Assembly procedure on the previous pages based on the power level being repaired.

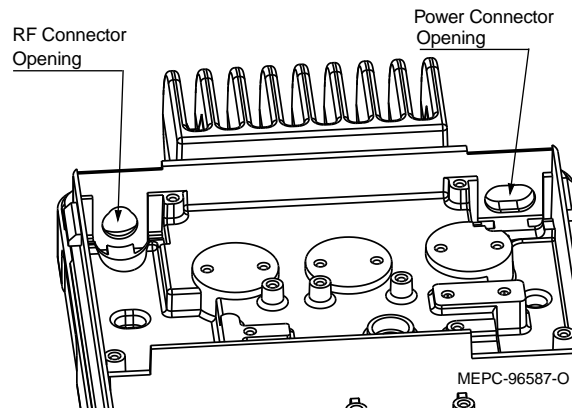

Figure 2-1 RF and Power Connector Openings

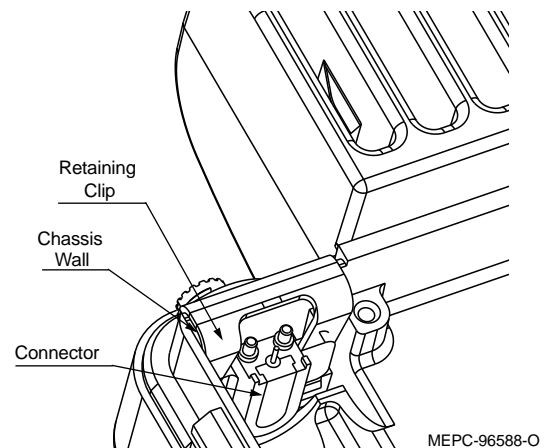

Figure 2-2 Install Connector Retaining Clip

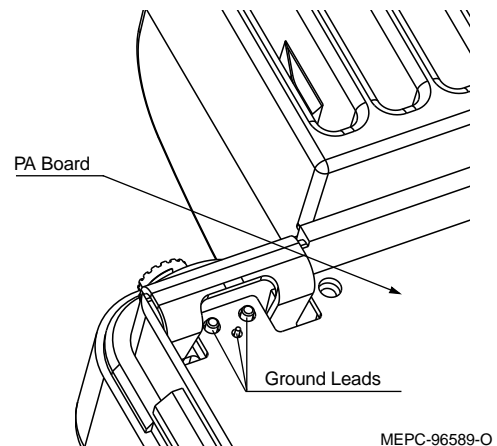

Figure 2-3 Replace PA Board

NOTES

Test Equipment, Service Aids, and Tools

3

Recommended Test Equipment

The list of equipment contained in the table below includes all of the standard test equipment required for servicing two-way mobile radios, as well as several unique items designed specifically for servicing the radio. Battery-operated test equipment is recommended when available. The “Characteristics” column is included so that equivalent equipment may be substituted; however, when no information is provided in this column, the specific Motorola model listed is either a unique item or no substitution is recommended.

Table 3-1 Recommended Test Equipment

Motorola Model Number	Description	Characteristics	Application
R2000 Series	System Analyzer	This monitor will substitute for items with an asterisk (*)	Frequency/deviation meter and signal generator for wide-range troubleshooting and alignment.
R1150C*	Code Synthesizer		Injection of audio and digital signalling codes.
S1053D* HM-203-7* SKN6008A* SKN6001A*	220 VAC Voltmeter 110 VAC Voltmeter Power Cable for Meter Test Leads for Meter	1mV to 300V, 10-Mohm input impedance	Audio voltage measurements.
S1350C* ST1213B (VHF)* (Superseded by ST1217B) ST1217B (VHF)* ST1223B (UHF)* (Superseded by ST1237B and ST1227B) ST1237B (UHF R1)* ST1227B (UHF R2)*	Watt Meter Plug-in Element Plug-in Element RF Dummy Load Plug-in Element Plug-in Element	50 ohm, ±5% accuracy 10 Watts, maximum 0-1000 MHz, 300W	Transmitter power output measurements.
T1013A (Supersedes R1065A)	Load Resistor	0-1000MHz, 300W	For use with Wattmeter.
R1065A (Superseded by T1013A)	Load Resistor	10-watt Broadband	For use with Wattmeter.
S1339A	RF Millivolt Meter 10kHz to 1.2 GHz	100µV to 3V rf	RF level measurements.
R1013A*	SINAD Meter		Receiver sensitivity measurement.
R1011B (Supersedes S1347D & S1348D)	DC Power Supply	0-40Vdc, 0-30 Amps	Current limited bench power supply.
S1347D or S1348D (programmable) (Superseded by R1011B)	DC Power Supply	0-20Vdc, 0-5 Amps	Current limited bench power supply.

* Any of the R2000 Series system analyzers will substitute for items with an asterisk (*)

Service Aids and Recommended Tools

Refer to the “SERVICE AIDS” and “RECOMMENDED TOOLS LIST” for a listing and description of the service aids and tools designed specifically for servicing the radio, as well as the more common tools required to disassemble and properly maintain the radio. These kits and/or parts are available from Motorola.

The following table lists service aids recommended for working on the radio. While all of these items are available from Motorola, most are standard shop equipment items, and any equivalent item capable of the same performance may be substituted for the item listed.

Field Programming

The radio can be aligned and programmed in the field. This requires specific equipment and special instructions. Refer to the “Radio Service Software User’s Manual” for complete field programming information.

Table 3-2 Service Aids

Part Number	Description	Application
RKN4062B	Programming and Cloning Cable	Connects the RIB RLN4008B to the microphone connector. Cloning is the act of transferring programmed data from one radio to another.
RKN4063A	FLASH, Programming and Cloning Cable with Test Box	Connects the RIB RLN4008B to the accessory connector. Cloning is the act of transferring programmed data from one radio to another. FLASHing is the act of adding new software to the radio.
3080376E36	Control Head Extender Cable	Connects the control head to the 18 pin connector. (see page 4 for correct use of this cable).
GTF373A*	Test Box Cable	Connects radio to GTF180B test box.
GTF372A*	Combined Interface Cable	Connects radio to RLN4008B RIB and Microphone Port and Accessory Connector.
HKN4191A	DC Power Cable for radios	Interconnects radio below 50 W to power supply.
HKN6110	DC Power Cable for radios	Interconnects radio of over 50 W to power supply.
RLN4460A or GTF180B*	Test Box	Allows switching for radio testing.
RLN4008B	Radio Interface Box	Enables communications between the radio and the computer’s serial communications adapter.
0180358A56 or EPN4041A*	Power Supply	Used to supply power to the RIB (220 VAC).
0180357A57	Power Supply	Used to supply power to the RIB (110 VAC).
EPN4040A*	Power Supply	Used to supply power to the RIB (240 VAC).
3080369B71 or 3080369B72	Computer Interface Cable	Use B72 for the IBM PC AT. All other IBM models use B71. Connects the computer’s serial communications adapter to the RIB.
RLN4438A	Adapter	25 pin (F) to 9 pin (M) adapter, for use with 3080369B72 for AT applications.
RLN1015B	Smart Radio Interface Box (SRIB)	Enables communications between the radio and the computer’s serial communications adapter. For FLASHing, programming and cloning.
0180302E27	SRIB Power Supply	Used to supply power to the SRIB (120 VAC).
2580373E86	SRIB Power Supply	Used to supply power to the SRIB (220 VAC).
RLN4488A	SRIB Battery Pack	Used to power the SRIB from a battery.
3080390B48 or 3080390B49	Computer Interface Cable	Use B49 for the IBM PC AT. All other IBM models use B48. Connects the computer’s serial communications adapter to the SRIB only.
2705438Y01 2705816W03 2705815W03	Chassis Eliminator Chassis Eliminator Chassis Eliminator	For Low Power radios. For Mid Power radios. For High Power radios.

Table 3-2 Service Aids

Part Number	Description	Application
TKN9152A	Securenet Keyload Adapter	Connects radio to Securenet Keyloader
3080370E05	Securenet Extender Cable	Connects the control head to the secure board.
RVN4113	Radio Service Software MCS 2000 Series	For programming of MCS 2000 radios with SmartNet/Zone, STARTSITE and Conventional StatAlert software. (3 1/2" floppy disc, English version)
GVN6011* (Eng) GVN6012* (Ger) GVN6013* (Fren) GVN6015* (Spa)	Radio Service Software 2000 & 2100 Series Select 5	For programming of MCS 2000 radios with Conventional Select 5 software. Only compatible with VHF and UHF 1-25 Watt models. (3 1/2" floppy disc)

* Available through Taunusstein Parts only.

The following table lists the tools recommended for working on the radio; these also are available from Motorola. Note that the R-1070A workstation requires the use of a specific "heat focus head" for each of the components on which this item is used. Each of these heat focus heads must be ordered separately.



Caution

The use of Mini UHF Adapters will have damaging effects on the RF Antenna Connector which might lead to radio failure.

Table 3-3 Recommended Service Tools

Part Number	Description	Application
0180381B45 110VAC or 0180300E06 220VAC	MBT250 Surface-mount/throu-hole repair station	Temperature-controlled, self-contained soldering/desoldering repair station for installation and removal of surface-mounted devices.
8180369E97	Flux holder/applicator	Allows for the proper amount of flux to be applied to pad grid arrays for repair.
1105139W02	30cc plastic syringe and flux paste	For use with flux holder/applicator 8180369E97.
0180386A81	Miniature digital read-out soldering station (incl. 1/64" micropoint tip)	
0180386A78	Illuminated magnifying glass with lens attachment	
0180386A82	Anti-static grounding kit	Used during all radio assembly and disassembly procedures
6684253C72	Straight prober	
6680384A98	Brush	
1010041A86	Solder (RMA type), 63/37, 0.020" diameter, 1 lb. spool	
R-1070A (superseded by R1319A)	Shields and surface-mounted component - IC removal/rework station	Removal of surface-mounted integrated circuits
R1319A (supersedes R1070A) 6680332E82 6680332E83 6680332E84	Surface-Mounted Device Rework Station R1319A Reflow Nozzle R1319A Reflow Nozzle R1319A Reflow Nozzle	Removal of surface-mounted integrated circuits For IC removal (approximate size 0.8 in. x 0.8 in.) For IC removal (approximate size 0.6 in. x 0.6 in.) For IC removal (approximate size 0.5 in. x 0.5 in.)
6685629A01	End Cutter	Extraction tool for removable control head buttons.
HLN6621	Plug, coaxial Mini UHF male connector. Note: this connector is delivered with the radio. Prior to installation, replace the RF connector provided with the antenna with this connector.	Recommended RF connector to interface with MCS 2000 radios. For use during bench test and tuning.

Connection of Control Head Extender Cable



Caution

Mid Power Chassis

Failure to follow these instructions may cause severe damage to the control head.

1. Place radio on bench with fins facing downward and away.
2. Remove the plastic cover. This position leaves the top side of the PC boards fully exposed and the 18 pin connector (see Table 3-4) facing the operator. Note that the 18 pin connector is offset left of center.
3. Place the control head directly in front of the chassis with the control head and chassis sides aligned to each other. The two 18 pin connectors **MUST** also be aligned. This means that the control head is sitting upright.



Caution

If the cable is plugged in upside down the control head will burn out.

4. With the colored side of the control head extender cable facing upward all the way between the control head and the chassis connect the cable to both control head and chassis 18 pin connectors.

High Power Chassis

1. Place radio on bench with fins facing downward and away.
2. Remove the polycarbonate cover. This position leaves the top side of the PC boards fully exposed and the 18 pin connector (see Table 3-4) facing the operator. Note that the 18 pin connector is offset right of center.
3. Place the control head directly in front of the chassis with the control head and chassis sides aligned to each other. The two 18 pin connectors **MUST** also be aligned. This means that the control head is upside-down on the bench.



Caution

If the cable is plugged in upside down the control head will burn out.

4. With the colored side of the control head extender cable facing upward all the way between the control head and the chassis connect the cable to both control head and chassis 18 pin connectors. After the cable is connected the control head can be uprigheted.

Table 3-4 Control Head Connector Pin Signals

PIN NUMBER	CONTROLLER SIGNAL	PIN NUMBER	CONTROLLER SIGNAL
1	INTERNAL SPKR+	10	DVP WE
2	SPKR-	11	KEY/FAIL
3	RESET	12	KID
4	SB9600_BUS-	13	DIGITAL_GND
5	not used	14	SB9600_BUSY
6	not used	15	SB9600_BUS+
7	ANALOG_GND	16	not used
8	HANDSET_AUDIO	17	A+
9	MIC/ON_OFF	18	SW_B+

Test Mode and Error Codes

Test Mode

General

The test mode allows the technician to monitor a set of radio parameters, to configure the radio hardware in a number of predefined ways, and have access to a number of test procedures. Two basic areas of functionality are provided by the Test Mode:

- RF test mode - allows the RF functionality of the radio to be tested.
- CH (Control Head) test mode - allows the radio display, buttons and switches to be tested.

The purpose of the test mode is to test the radio unit and its interfaces, but not to test the various accessories. However, the mobile radio is incapable of operating in isolation without a minimum set of accessories. The following accessories are assumed:

- Keypad or noise cancelling microphone
- External speaker (only models II and III)
- Control head model I, II or III

If an accessory is subsequently connected to the radio after the test mode application has already been invoked, the radio will ignore any resulting power up messages received on the serial bus.

Test Mode Features

On entering Test Mode the radio will be in an idle state, all indicators are extinguished and the RF TEST Mode Select menu message will be displayed.

Test mode control is provided by a set of menus which may be scrolled through and selected. The dedicated buttons TM1 (Select) and TM2 (Scroll) (see Figure 4-1 on page 2) are used to navigate through these menus.

Test Mode Entry and Exit

1. Turn the radio on.
2. Within five seconds after power on press the TM1 five (5) times.
3. On entry, the SERVICE test mode message is displayed for 2 seconds. Following this, each of the following is displayed in sequence:
 - radio software part number
 - control head part number
 - radio model number
 - radio serial number

Each of these “temporary messages” lasts for 2 seconds. After the radio serial number has been displayed for 2 seconds, the message RF TEST will show in the display after 2 seconds.

4. To exit either the RF Test Mode or the CH Test Mode turn the radio off.

- Button TM1: used as Select Key and for Test Mode Entry
- Button TM2: used as Scroll Key

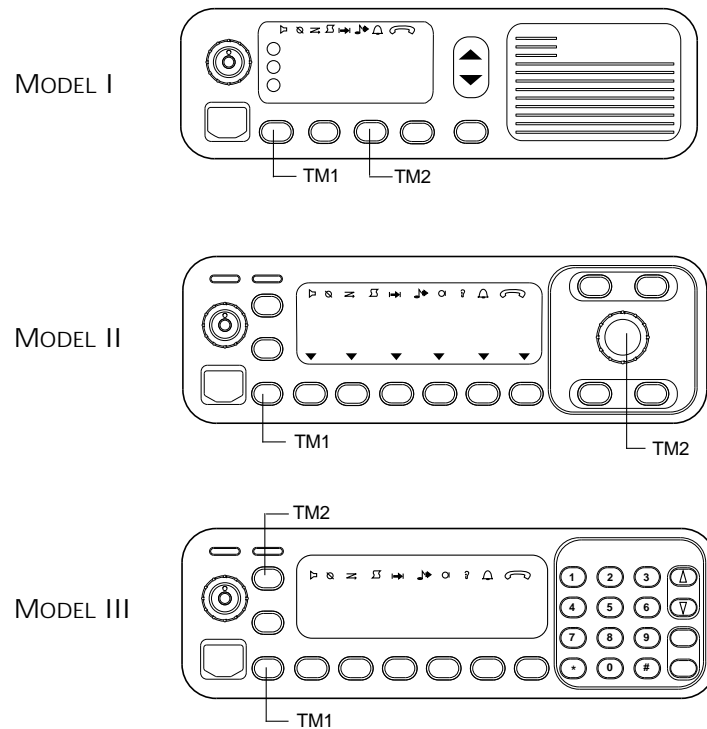

Figure 4-1 Dedicated Test Mode Keys on Models I, II and III

RF/CH Test Mode Select

Pressing the scroll key alternates between the two Mode Select menus RF TEST and CH TEST. To select either the RF or CH test menu press the dedicated select key while the desired menu is being displayed.

RF Test Mode

On entry into the RF test mode the radio hardware will be configured for the default carrier squelch (CSQ) test mode environment. The test mode application will examine the following personality parameters in the radio codeplug:

- Tx Channel Number.
- Rx Channel Number.

When the radio is in RF test mode the PTT button is used to key and dekey the transmitter. Whenever the transmitter keys up, the test mode application illuminates the front panel red LED and whenever the transmitter keys down the application extinguishes the front panel red LED.

Test Mode Environments

When the RF TEST menu is displayed, press the TM1 key to gain access to the RF test mode environments:

- CSQ (Carrier Squelch). . . (Default)

- TPL (Tone Private Line)
- DPL (Digital Private Line)
- TLS (Trunking Low Speed)
- THS (Trunking high speed)
- DTM (Dual Tone Modulation Frequency)
- M12 (MDC 1200)

When the appropriate environment is selected the test mode application will configure the radio hardware for this environment.

Channel Numbers

When the cursor is blinking on the channel number field, TM2 will scroll through channels: 1, 2, ...n (n is the highest channel number specified by the Tx/Rx pairs field). The test mode application will examine the number of Tx/Rx pairs field contained in the personality area of the radio codeplug in order to determine how many different channel number menu messages to display. Selecting one of the channel numbers will reconfigure the radio hardware with the specific transmit/receive frequency.

The resulting frequencies will be as follows:

- Transmit frequency: Offset frequency + (Tx channel number #n * Channel step size).
- Receive frequency: Offset frequency + (Rx channel number #n * Channel step size).

The Rx/Tx channel number #n and Channel step size values are extracted from the personality area of the radio codeplug and the offset frequency is derived from the offset frequency calculation performed on entry into RF test mode.

CH Test Mode

On entry into the Control Head test mode, all front panel indicators and display segments are displayed for a period of 2 seconds, and then extinguished.

When the radio is in Control Head test mode, all front panel momentary button presses/releases (apart from the dedicated scroll and select keys and the volume control), static switch activations and free revolving rotary activations are monitored. When any one of these is detected a short tone will be heard and the associated button code (in decimal) and state will be displayed on the front panel.

Error Code Displays

Power-up Display Codes

At power-up, the radio performs cursory tests to determine if its basic electronics and software are in working order. Problems detected during these tests are presented as error codes on the radio display. The presence of an error code should prompt the user that a problem exists and that a service technician should be contacted.

Self-test errors are classified as either fatal or non-fatal. Fatal errors will inhibit user operation, while non-fatal errors will not. Use Table 4-1 to aid in understanding particular power-up error code displays.

FAILURE DISPLAY	TYPE OF FAILURE	DESCRIPTION	POSSIBLE SOURCE
FAIL 01/81	FATAL	External ROM/Flash checksum error	Bad ROM data, Defective ROM
FAIL 01/82	FATAL	External EEPROM checksum error	Bad external codeplug data, Defective external EEPROM
ERROR 01/02	NON-FATAL	External EEPROM checksum error	Bad external codeplug data
FAIL 01/84	FATAL	External EEPROM checksum blank	Unprogrammed external codeplug data
FAIL 01/88	FATAL	External RAM error	Defective RAM
FAIL 01/90	FATAL	Hardware failure	Defective IC
FAIL 01/92	FATAL	Internal EEPROM checksum error	Bad internal codeplug data, Defective microcontroller
FAIL 01/93	NON-FATAL	Internal EEPROM checksum blank	Failure of Flashport authorization code
FAIL 01/94	FATAL	Internal EEPROM checksum blank	Unprogrammed internal codeplug data
FAIL 01/98	FATAL	Internal RAM error	Defective microcontroller
ERROR 01/12	NON-FATAL	Internal EEPROM checksum error	Bad internal codeplug data
ERROR 09/10	FATAL	Hardware failure	Defective secure board, Missing secure board

Table 4-1 Power Up Display Codes



Due to the nature of fatal ROM & RAM errors, it may not be possible to present an error code on the display. In these cases the radio will attempt to display the appropriate error code, generate an illegal mode tone for one second and then reset its microcontroller.

Operational Display Codes

During operation, the radio performs dynamic tests to determine if it is working properly. Problems detected during these tests are presented as error codes on the radio display. The presence of an error code should prompt a user that a problem exists and that a service technician should be contacted. Use Table 4-2 to aid in understanding particular operational error code displays.

FAILURE CODE	DESCRIPTION	POSSIBLE SOURCE
FAIL 001	Synthesizer out of lock	Bad frequency data in codeplug; defective synthesizer
FAIL 002	Selected Mode (Zone/Channel) codeplug checksum error	Bad codeplug data

Table 4-2 Operational Display Codes

Disassembly & Reassembly and Replacement Procedures

5

General

The disassembly/reassembly procedure covers all radio models. Specific model information is included in the procedure where relevant. Where nothing is indicated, the procedure will be valid for all models.



DO NOT attempt to disassemble the radio without first referring to the CMOS Precautions paragraph on page 2-2 in the Maintenance section.

Disassembly to Transceiver Board Level Low and Mid Power Models

Remove the Control Head



Steps 1 and 2, Removal of the Retention Frame, are only valid for Models II and III, Low and Mid Power Dash Mount version radios.

1. **On Models II & III, Dash Mount only:** Prior to removing the control head, remove the retention frame by inserting a small flat blade screwdriver in the cut outs provided.
2. **On Models II & III, Dash Mount only:** Slide the retention frame away from the control head groove.
3. Insert a small blade screw driver or like instrument in the side groove at the interface between the control head and the transceiver (see Figure 5-1). While pulling the control head away from the transceiver press until the control head side releases, and then repeat the operation on the opposite side.

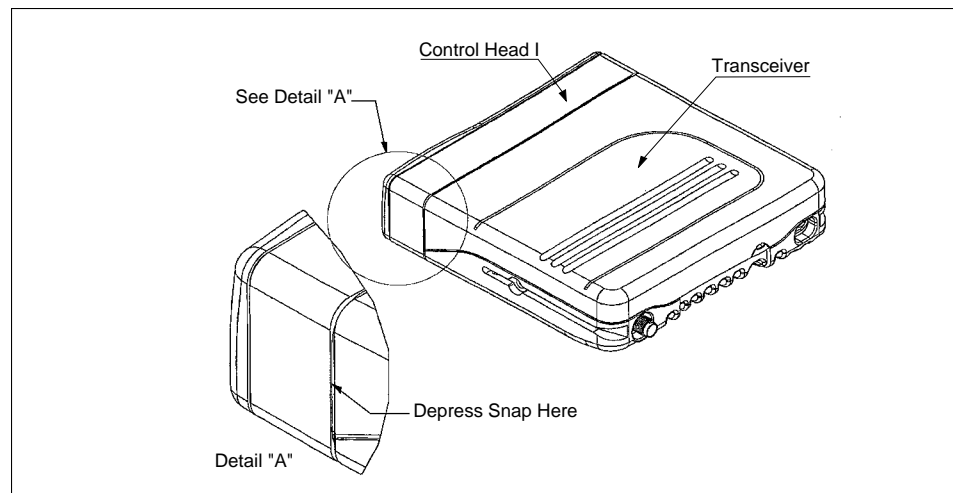

Figure 5-1 Removing the Control Head



Caution

The control head must be removed before removing the transceiver top cover.

Remove Front Housing

REMOTE MOUNT
VERSION MODELS ONLY

4. Pull the control head off of the transceiver while pressing the snaps. (Go to “Remove the Top Cover” section below).
1. Disconnect the Remote Mount Cable by squeezing the top and bottom of the connector together, disengaging the bottom snap then the top and pulling straight out.
2. Insert a small flat-blade screwdriver or like instrument in the side groove at the interface between the remote front housing and the transceiver (see Figure 5-1). Press while pulling the housing away from the transceiver until the snap releases. Repeat the operation on the opposite side.
3. Remove the 18 position connector from the front of the transceiver.
4. Pull housing off the transceiver.

Remove the Top Cover

LOW POWER MODELS

1. Pry the cover free from the chassis by inserting a small flat-blade screwdriver or like instrument into the area shown in Figure 5-2 and rotating the handle of the screwdriver over the top of the radio. This will disengage the snap between the cover and chassis. Rotate the cover away from the chassis and pull off. (Go to “Remove the Cavity Shield” paragraph, page 5-3).

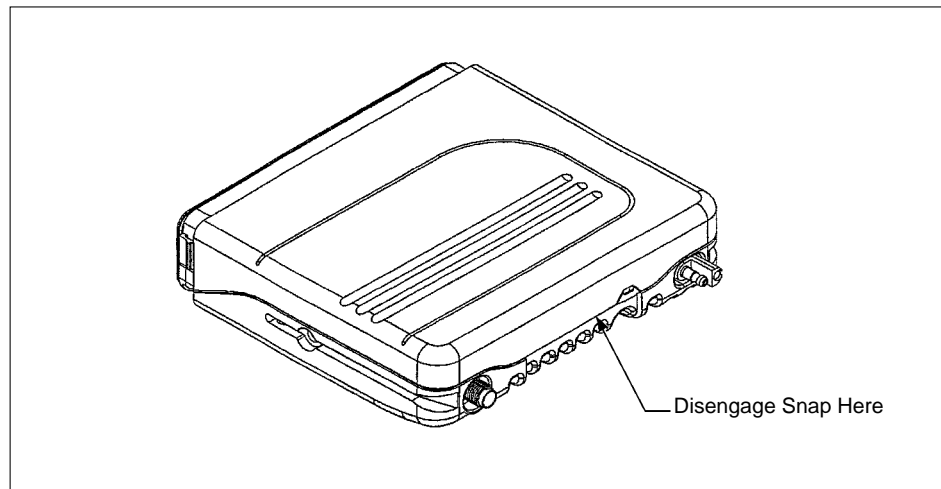

Figure 5-2 Removing the Top Cover - Low Power Models

MID POWER MODELS

1. Insert a wide flat-blade screwdriver or like instrument in the recess area on the side of the radio near the RF and DC connector end (see Figure 5-3).
2. Pry the cover off the chassis by pushing the handle of the screwdriver up and toward the radio. This will disengage the snap between the cover and chassis.

3. Repeat Step 1. and Step 2. for the opposite side of the radio.

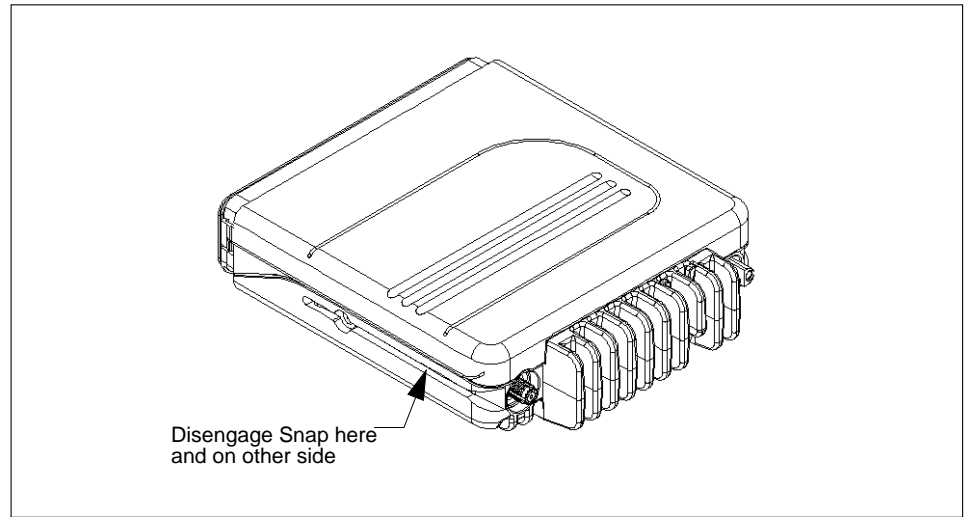

Figure 5-3 Removing the Top Cover - Mid Power Models

Remove the Cavity Shield

LOW POWER MODELS
ONLY



Eight tabs hold the cavity shield to the chassis. The cavity shield is the retaining device for the transceiver board and also provides the pressure to heat dissipating devices attached to the chassis.

1. Remove the cover gasket from the chassis.
2. Loosen the cavity shield by prying each of the eight tabs away from the chassis. Release the four tabs on one side first and then repeat the operation on the other. Be careful not to pry the tabs any more than is necessary to free them from their respective retaining posts (see Figure 5-4).
3. Pull straight up on the cavity shield.

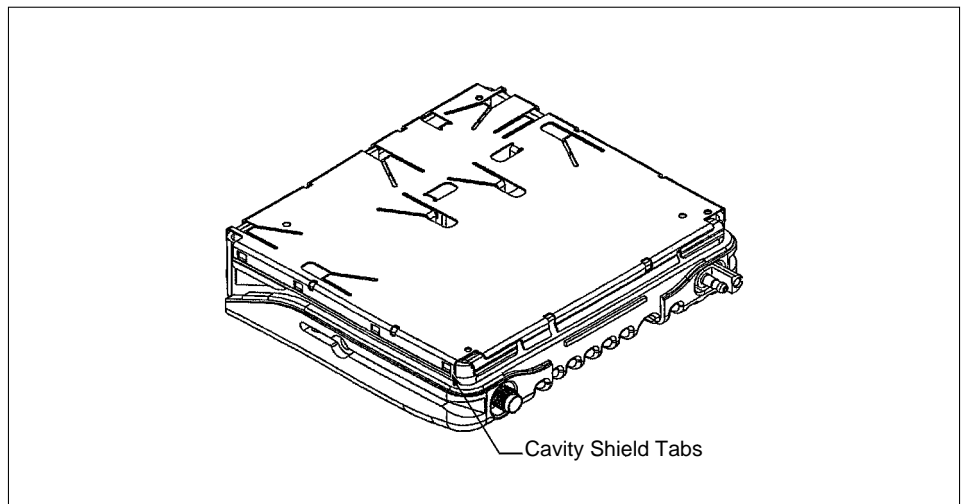

Figure 5-4 Removing the Cavity Shield

Remove the PA
Shield
LOW AND MID POWER
MODELS

1. Unscrew the three screws that hold the PA shield with T-10 TORX driver.
2. Remove the PA shield by pulling straight up on the attached handle.

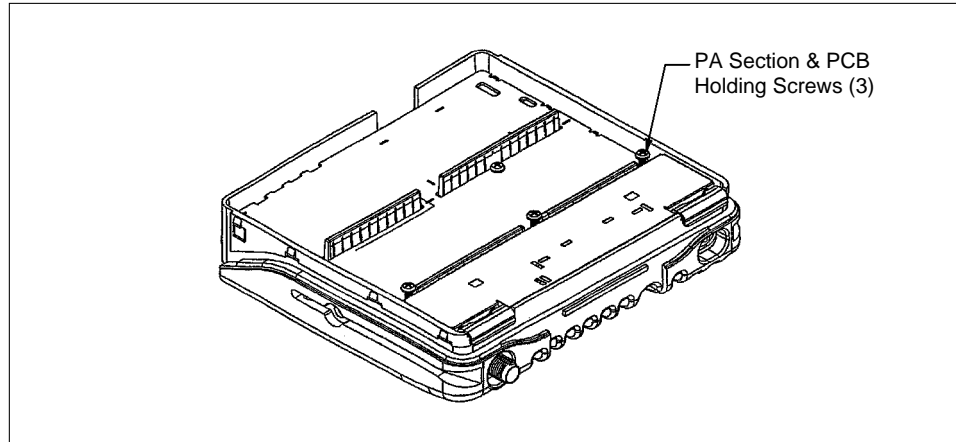

Figure 5-5 Removing the PA Shield (Low and Mid Power Models)

Remove the
Transceiver Board
EXCEPT 800 MHz AND
900 MHz



For 800 MHz and 900 MHz radios go to page 5-6.

LOW POWER MODELS

1. Remove the Accessory Connector by sliding a finger into the recess on the chassis and pushing up on the connector tab to loosen the connection. Lift the connector out of the recess.
2. Remove all screws using a T-10 TORX driver. Remove the power and antenna connector retaining clips by inserting a small flat blade screwdriver between the clip and the top of the chassis wall and gently prying upwards (see Figure 5-6).



Thermal grease can act as an adhesive and cause the leads of the the power amplifier devices to be over stressed if the board is lifted too quickly.

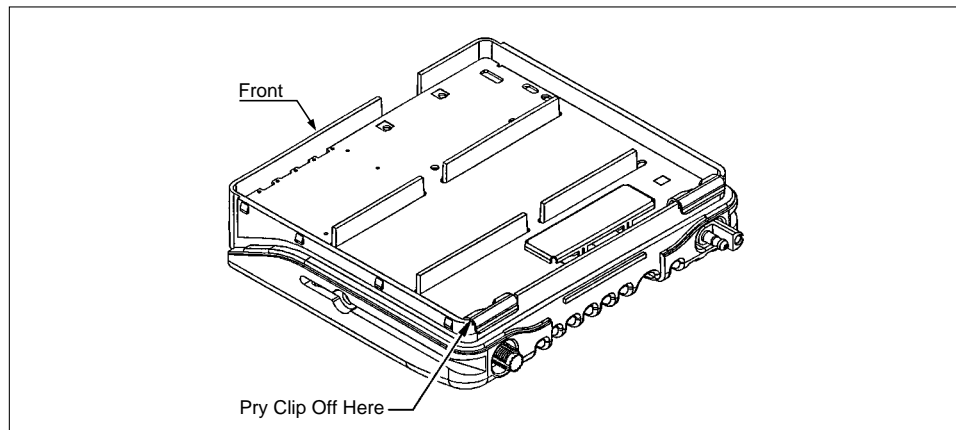

*Figure 5-6 Removing the Transceiver Board - Low Power Models
(except 800 MHz and 900 MHz)*

MID POWER MODELS

3. Carefully remove the transceiver board by rotating it out of the chassis. Slowly lift the board on the front edge while pushing up on the board through the accessory connector opening. Pull the board forward out of the chassis.
1. Remove the Accessory Connector by sliding a finger into the recess on the chassis and pushing up on the connector tab to loosen the connection. Lift the connector out of the recess.
2. Remove the power and antenna connector retaining clips by inserting a small flat-blade screwdriver or like instrument between the clip and the top of the cavity wall per area shown in Figure 5-6. Gently prying upwards.
3. Remove the PCB Clip and the Audio PA clip by inserting a flat-blade screwdriver or like instrument between the clip and the side wall. Prying the clip upward to disengage with the tabs on the wall.
4. Remove the four recessed Power Amplifier Device screws using a T-8 Torx Driver (see Figure 5-7).
5. Remove the remaining screws with a T-10 Torx Driver.
6. Carefully remove the transceiver board by rotating it out of the chassis. Slowly lift the board on the front edge while pushing up on the board through the accessory connector opening. Pull the board forward out of the chassis.



Thermal Grease can act as an adhesive and cause the leads of the power amplifier devices to be over stressed if the board is lifted too quickly.

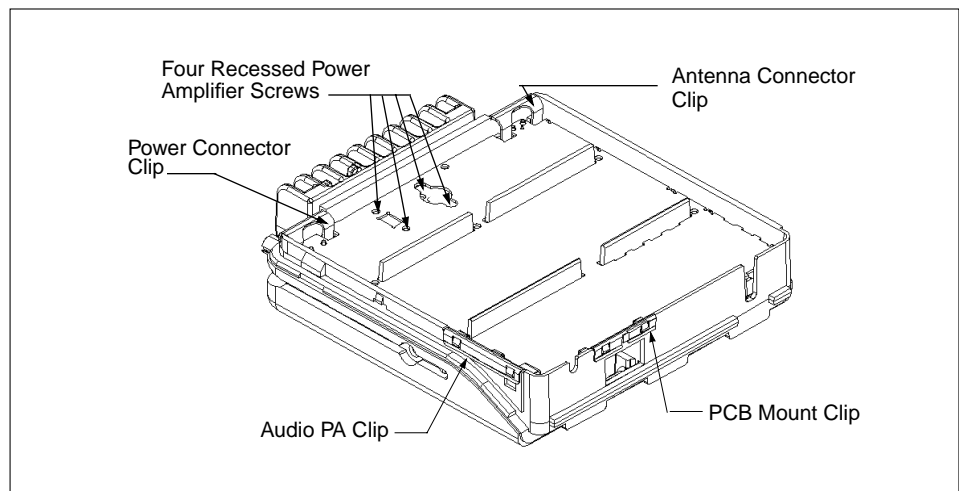

Figure 5-7 Removing the Transceiver Board - Mid Power Models (except 800 MHz and 900 MHz)

Remove the
Transceiver Board
800 MHz AND 900 MHz
MODELS ONLY

1. Remove the Accessory Connector by sliding a finger into the recess on the chassis and pushing up on the connector tab to loosen the connection. Lift the connector out of the recess.
2. Remove all screws using a T-10 TORX driver.
3. Remove the power and antenna connector retaining clips by inserting a small flat blade screwdriver between the clip and the top of the cavity wall and gently prying the clip upwards.
On Mid Power models: Remove the PCB clip and the Audio PA clip by inserting a flat-blade screwdriver or like instrument between the clip and the side wall. Prying the clip upward to disengage with the tabs on the wall.
4. Press on the 25 pin connector through the bottom of the chassis until the board is released from the chassis.
5. Carefully remove the transceiver board by rotating it out of the chassis. Slowly lift the board on the front edge while pushing up on the board through the accessory connector opening (see Figure 5-8).

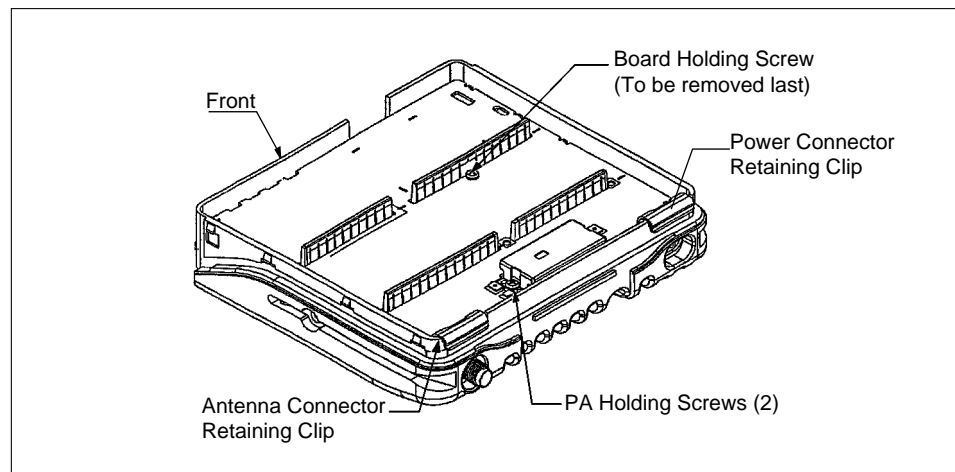

Figure 5-8 Removing the Transceiver Board (800 MHz and 900 MHz only)

Disassembly to Transceiver Board Level High Power Models



Caution

Remove the
Bottom Cover

DO NOT attempt to disassemble the radio without first referring to the CMOS Precautions paragraph on page 2-2 in the Maintenance section.

1. Disconnect the Remote Mount Cable by squeezing the top and bottom of the connector together, disengaging the bottom snap then the top, and pulling straight out.
2. Flip the unit over so that the Bottom Cover is facing up.

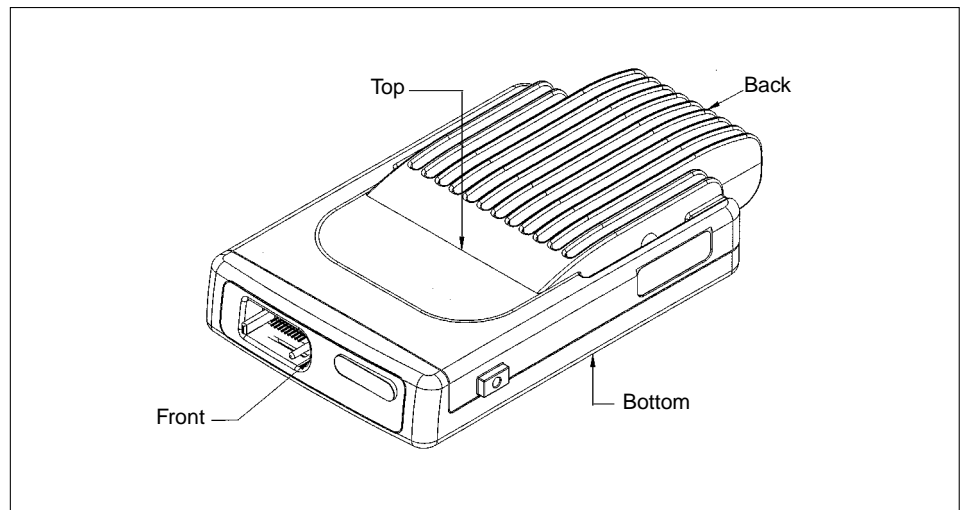

Figure 5-9 Direction Conventions

3. Remove the Accessory Connector by sliding a finger into the recess on the bottom cover and pushing up on the connector tab to loosen the connection. Lift the connector out of the recess. See Figure 5-10.

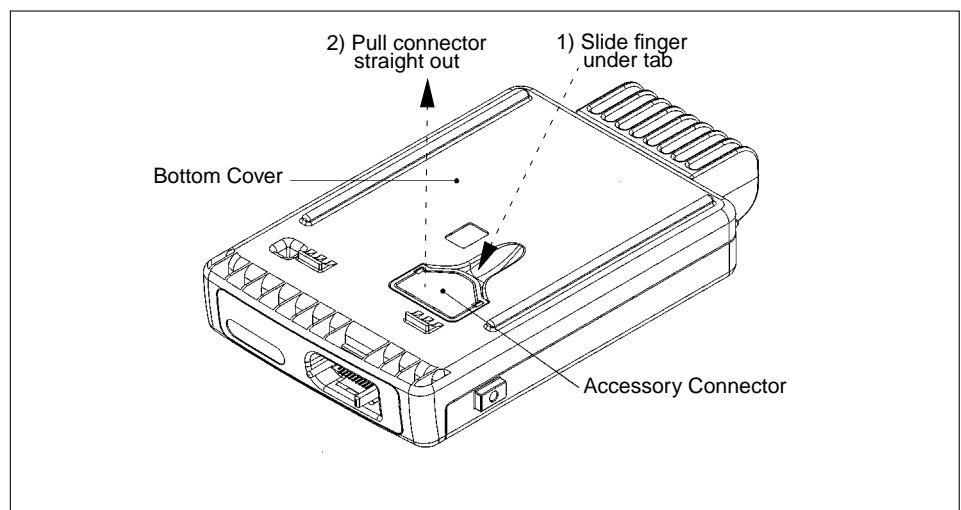

Figure 5-10 Removing the Accessory Connector

4. Insert a wide flat-blade screwdriver or like instrument in the recess area on the side of the radio near the antenna and power connector ends (see Figure 5-11).
5. Pry the bottom cover off the chassis by pushing the handle of a screwdriver up and toward the radio. This will disengage the snap between the bottom cover and the chassis.
6. Repeat Step 4. and Step 5. for the other side of the radio.
7. Rotate the bottom cover out and away from the chassis until it is completely free of the chassis taking care not to damage the 18 position connector in the process.

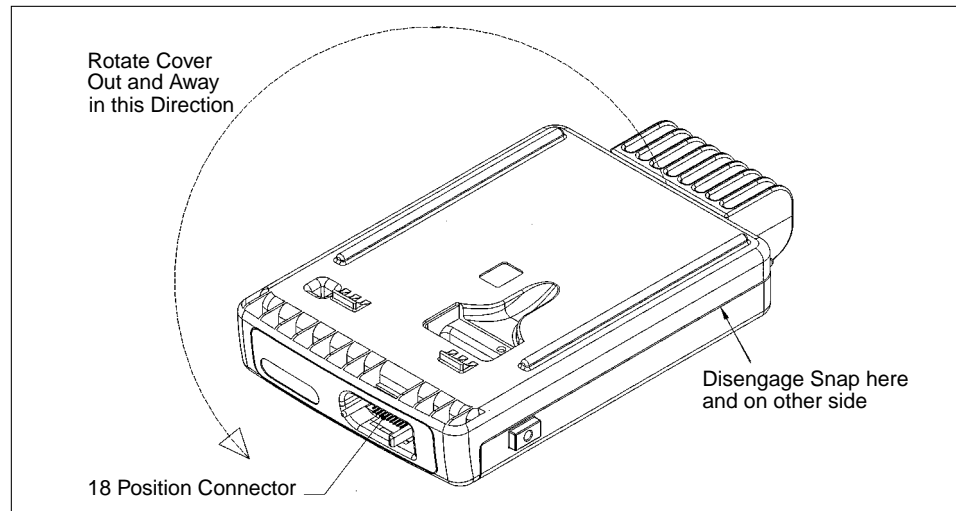

Figure 5-11 Removing the Bottom Cover

8. Remove the cover gasket from the chassis.
 1. Pull straight up on the RF shield using the supplied handle.

Remove the RF Shield

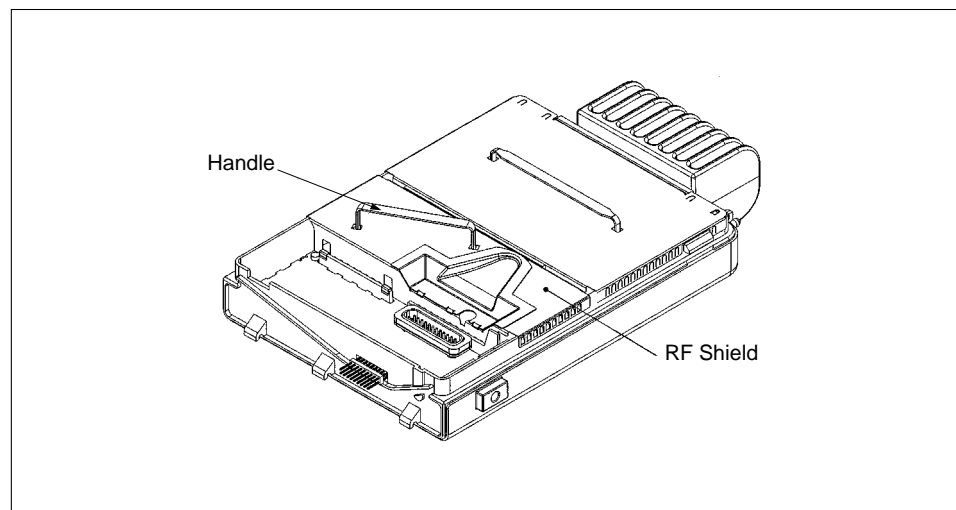

Figure 5-12 Removing the RF Shield

Remove the PA Shield

1. Pull straight up on the PA shield using the supplied handle.

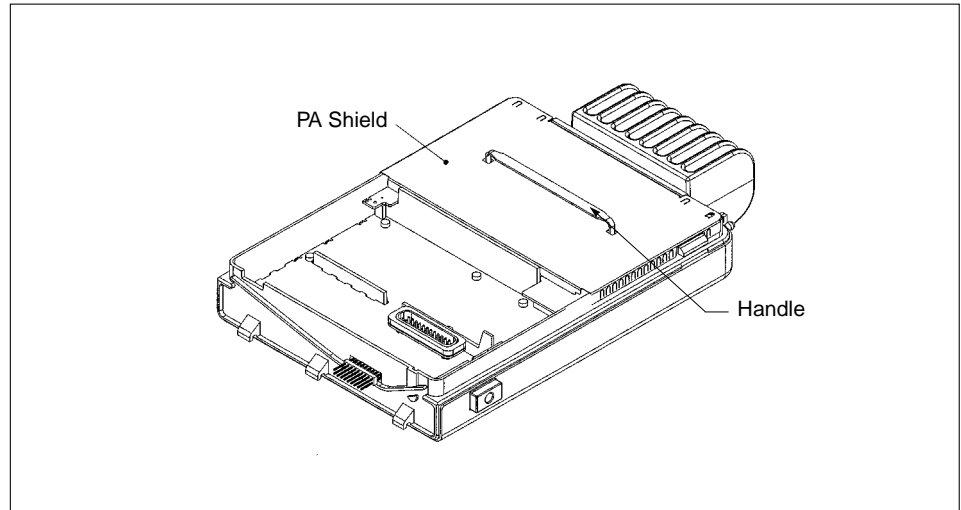

Figure 5-13 Removing the PA Shield

Remove the PA Board

1. Unscrew the 6 recessed, PA device screws using a T-8 Torx driver. Unscrew the remaining screws (9 for VHF, 11 for UHF) using a T-10 Torx driver.
2. Remove the power and antenna connector retaining clips by inserting a small flat-blade screwdriver between the clip and the underlying cavity wall and by gently prying the clip upwards.
3. Gently disconnect the 2 and 12 position connectors from the RF board by rotating the PA Board toward the chassis fins.
4. Once the connectors are disengaged, remove the PA Board from the chassis by pulling edge of board up and away from fin (back) side of radio.

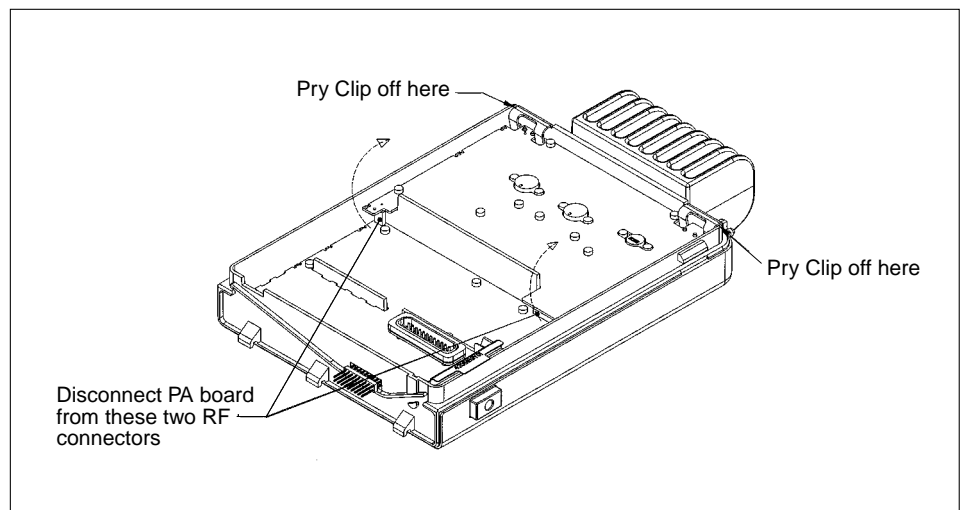

Figure 5-14 Removing the PA Board

Remove the RF Board

1. Remove the 18 position connector by pulling it straight out from the chassis taking care not to bend the leads.
2. Remove the Audio PA Clip by inserting a flat-blade screwdriver under the clip's extended tab, pivoting off the top of the underlying wall, and gently prying the clip upward.
3. Unscrew the 7 screws that hold the RF board in place using a T-10 Torx driver.
4. Carefully remove the RF board from the chassis by pulling straight up on the 25 D connector.

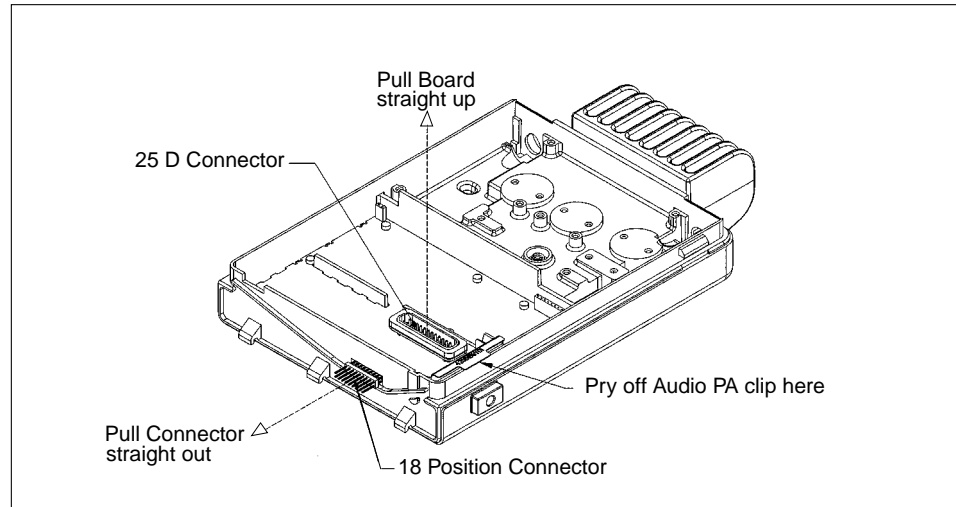

Figure 5-15 Removing the RF Board

Disassembly of the Control Head

Remote Mount Versions

1. Disconnect the Remote Mount Cable by squeezing the top and bottom of the connector together, disengaging the bottom snap then the top, and pulling straight out.
2. Remove the back housing by inserting a small flat-blade screwdriver or like instrument into the recess on the short side of the control head exterior, taking care not to mar the surface. Rotate the screwdriver so that the tab deflects out and disengages from the control head housing.
3. Repeat the operation in Step 2. for the opposite side.

Model I

1. Remove the internal spacer by inserting a small flat-blade screwdriver or like instrument into one of the eight recesses around the perimeter of the spacer. Rotate the screwdriver so that the spacer deflects in and the tab disengages from the control head housing.
2. Repeat Step 1. for the remaining seven recesses.
3. Pull the control head board straight out from the control head housing, removing the control head board, the speaker, and the keypad together.
4. Remove the keypad from the PCB by pulling up on the keypad. Care is required in removing the keypad from around the volume potentiometer and the microphone connector to keep from overstressing the leads. Care should be taken not to touch or get other contaminants on the conductive pads on the underside of the keypad.
5. To remove the LCD gasket, first remove the elastomeric connector, the LCD frame, the colour sheet and the LCD itself from the housing.
6. Disconnect the speaker lead from the connector on the control head board.

Models II & III STANDARD KEYPAD

1. Pull the back housing straight off.
2. **On Model II**, also remove the rotary knob on the right side of the unit by pulling away from the control head.
3. Remove the control head board by prying back on the four visible light pipe snaps. Carefully remove the board from the housing. Gently pull the board straight up so not to damage the volume potentiometer and the microphone connector leads.
4. The light pipe can be removed by prying back on its plastic snaps from the recesses in the control head housing. This step is only required to gain access to the keypad.
5. With the light pipe removed, the keypad can be pulled from the housing. Care should be taken not to touch or get other contaminants on the conductive pads on the under side of the keypad.

Models II & III KEYPAD WITH REPLACEABLE PUSH BUTTONS

1. Remove the back housing by inserting a small flat-blade screwdriver or like instrument into the recess on the short side of the control head exterior, taking care not to mar the surface. Rotate the screwdriver so that the tab deflects out and disengages from the control head housing.
2. Repeat the operation in Step 1. for the opposite side.
3. Pull the back housing straight off.

4. **On Model II**, also remove the rotary knob on the right side of the unit by pulling straight up.
5. Remove the control head board by prying back on the four visible light pipe snaps. Carefully remove the board from the housing. Gently pull the board straight up so not to damage the volume potentiometer and the microphone connector leads.
6. The light pipe can be removed by prying back on its plastic snaps from the recesses in the control head housing. This step is only required to gain access to the keypad.



Care should be taken when removing the light pipe from control heads equipped with replaceable pushbuttons as the buttons are loose in the housing under the keypad.

7. With the light pipe removed, the keypad can be pulled from the housing. Care should be taken not to touch or get other contaminants on the conductive pads on the underside of the keypad.

Reassembly of the Control Head

Model I

1. Place the LCD, colour sheet, LCD frame, and elastomeric connector into the housing. Make sure that the LCD aligns with the gasket in the housing.
2. Place the keypad into the board assembly, making sure that the keypad is flush with the board.
3. Make sure that both the volume knob and potentiometer are both fully in the counter clockwise position before assembling the board into the housing.
4. Also make sure that the speaker is aligned with the speaker gasket and connected to the board assembly.
5. During the installation of the internal speaker be sure that all eight snaps are engaged. Be sure not to crimp the speaker wire.

Models II and III

1. Place the keypad into the control head housing.
2. Snap the light pipe into the housing. Alternate engaging snaps on each side for best result.
3. Make sure that both the volume knob and potentiometer are both fully in the counter clockwise position before assembling the board into the housing.
4. Snap the board assembly into the housing.
5. For model "II" only, attach the large rotary knob.

Transceiver Reassembly

Low and Mid Power Models

Transceiver Reassembly



- Replace all gaskets at each servicing to ensure proper sealing of unit.
 - Be careful to use only very little thermal grease as an excessive quantity will deteriorate the conductivity.
1. Inspect and reapply thermal grease as needed to the areas shown in Figure 5-16.

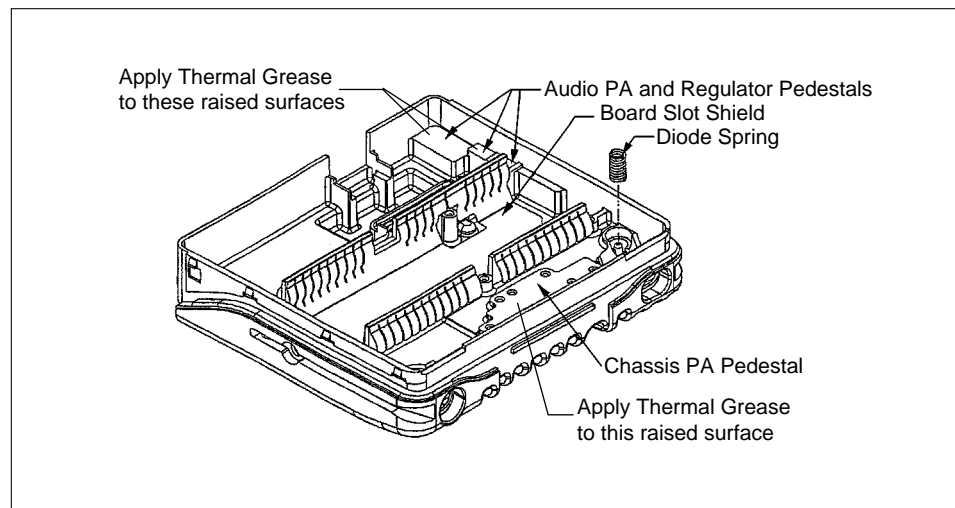

Figure 5-16 Reassembly

2. Insert the diode spring.
3. Install a new gasket to the 25 pin connector, Antenna connector and Power connector gaskets located on the board.
4. **On 800/900 MHz Models only:** Insert board slot shield.
5. Replace the thermal pad attached to the large heatsink (designator B6501) on the bottom side of the board in the PA section.
6. Insert the main board carefully at an appropriate angle (approximately 30°) into the chassis.
7. Install the antenna and power connector retaining clips.
8. **On Low Power Models Only:** Install all screws (except the three screws that retain the PA shield) with 12 in lbs of torque using a T-10 Torx driver.
On Mid Power 800/900 MHz Models: Install all screws (except the three screws that retain the PA shield) with 12 in lbs of torque using a T-10 Torx driver.
On Mid Power Models (Excluding 800/900 MHz): Install the four screws in the recessed PA devices with 12 in lbs of torque using a T-8 Torx

driver (see Figure 5-7). Install the remaining screws (except the three screws that retain the PA shield) with 6-8 in lbs of torque using a T-10 Torx driver.

9. **On Mid Power Models Only:** Install the PCB and Audio PA clips.
10. Insert the PA shield. Tighten the three screws that hold it to the PCB and the one screw in the middle of the board with 6-8 in lbs of torque using a T-10 Torx driver.
11. **On Low Power Models:** Install the Cavity Shield and press down until it locks on the chassis tabs.



Ensure that ALL cavity shield tabs engage properly. Failure to do this may inhibit the top cover from engaging properly and could damage the top cover.

12. Place a new cover gasket around the chassis ensuring that it is placed under the locking tabs and ledge at the front of the chassis. To ensure that the gasket remains seated along the groove, twist the gasket between fingers down and toward the chassis on both sides of the chassis.
13. Install the top cover by engaging the hooks on front of the chassis and rotating the cover back. Ensure that the side snaps on the cover are engaged.
14. Install the front cover gasket over the front of the transceiver ensuring that the rectangular hole in the transceiver aligns with the rectangular hole in the gasket. Press the gasket flush against the transceiver to ensure proper sealing.

Assembly of Control Head to Transceiver

DASH MOUNT MODELS

1. **For Model I:** Install dash mount configured control head onto the transceiver. Ensure that the side snaps are engaged.
For Models II and III: Install the retention frame over the front of the transceiver. Install the dash mount configured control head onto the transceiver. Slide the retention frame toward the control head until both snaps engage.

REMOTE MOUNT MODELS

1. Install the 18 position connector into the female connector (mounted on the PC board) through the hole in the front of the chassis.
2. Install the remote header retainer into the recess for the rectangular cutout in the remote front housing.
3. Install the remote front housing over the 18 position connector onto the front of the transceiver ensuring that both snaps are engaged.
4. Connect the remote mount cable to the transceiver and to the remote mount configured control head.

Transceiver Reassembly High Power Models



Replace all gaskets at each servicing to ensure proper sealing of unit.

1. Inspect and reapply a thin coat of thermal compound as necessary to the heatsinking pads, voltage regulator and Audio PA areas in the chassis per Figure 5-17. A thick coat of thermal compound may negatively effect heat sinking.

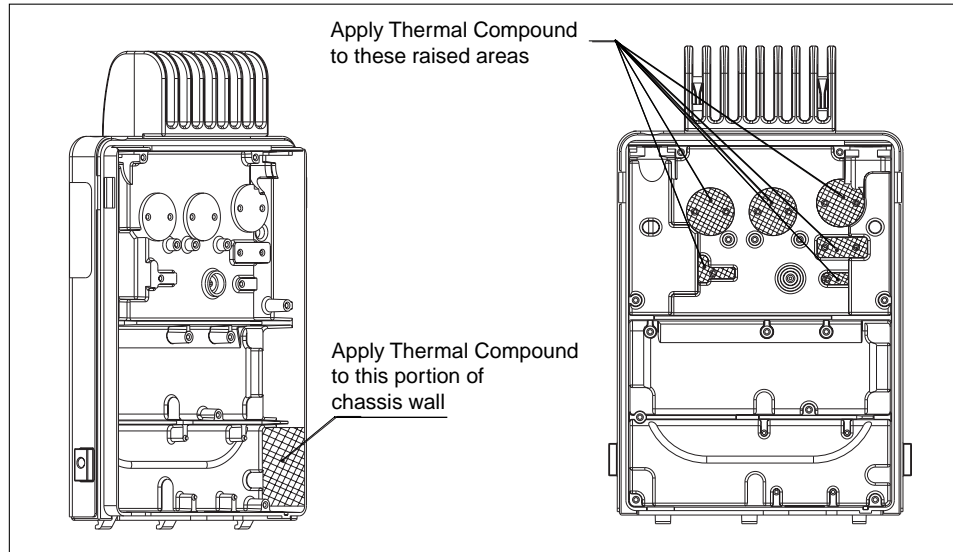

Figure 5-17 Wakefield / Thermal Compound Application Area

2. Insert the transceiver board placing board slots over locating features in chassis. Be sure the board is sitting flush on the chassis mounting surface.

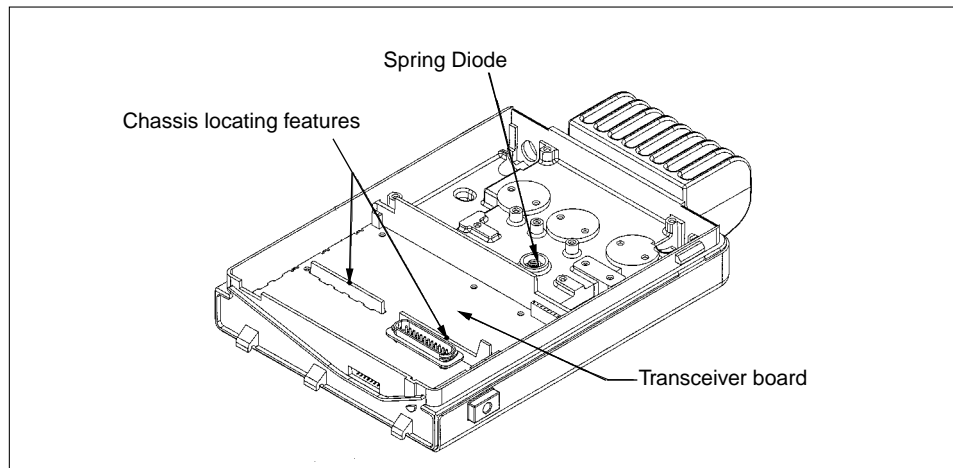

Figure 5-18 Inserting Transceiver Board

3. Replace the 25-D connector gasket on the transceiver board.
4. Replace the RF and power connector gaskets on the PA board.
5. Install the PA board carefully at an appropriate angle (approximately 30°) to the chassis connecting the 2 and 12 pin connectors to the RF board.
6. Install the 2 PA connector retaining clips over the RF and power connectors and chassis wall.



Observe the screw-down sequence in Figure 5-19 when installing screws. Proper alignment of boards depend on following this sequence.

7. Fasten screws #1-6 to 12 in lbs of torque using a T-8 Torx driver. Fasten the remaining screws (#7-20 for VHF models, #7-22 for UHF models) to 6-8 in lbs of torque using a T-10 Torx driver following the screw down sequence in Figure 5-19.

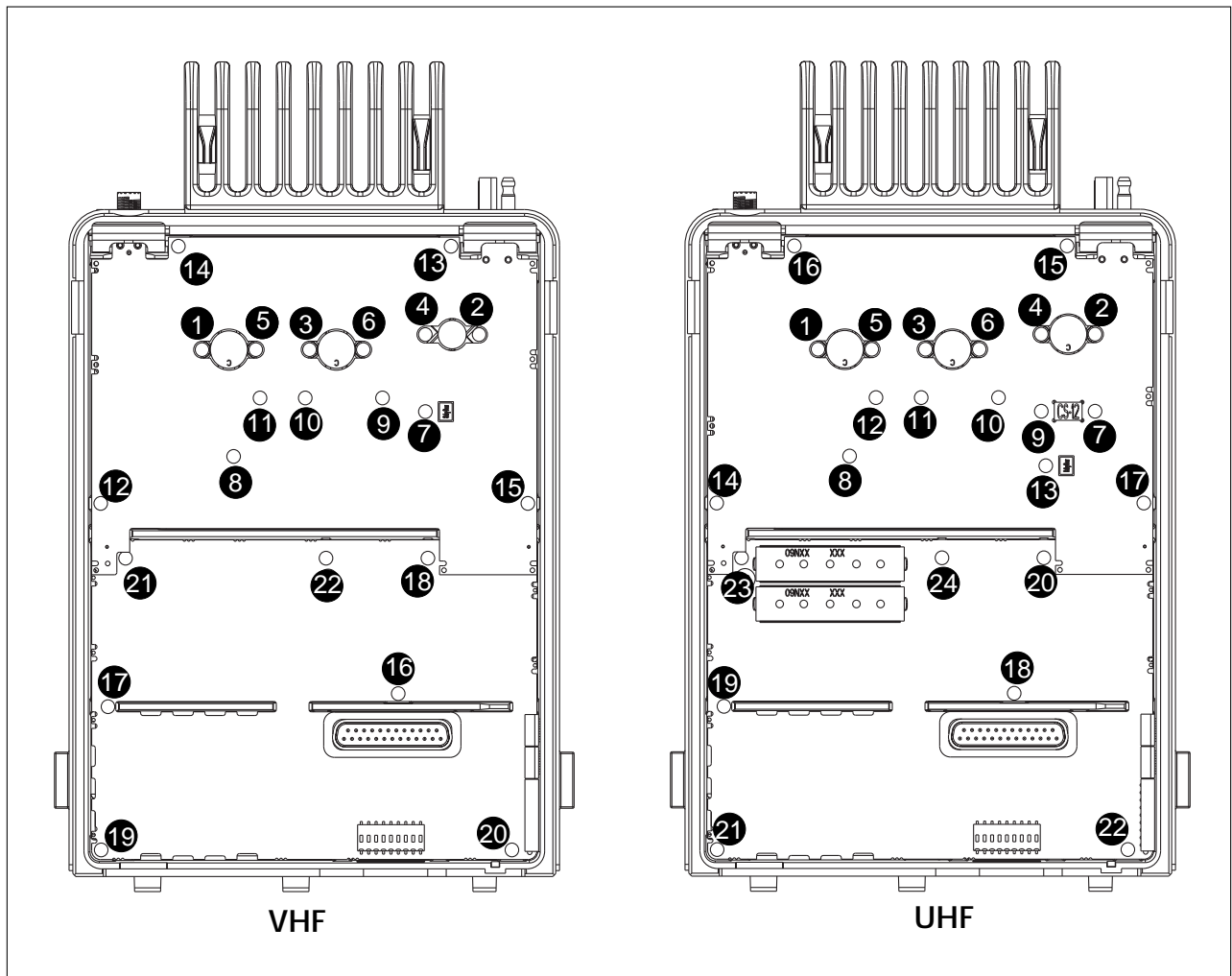

Figure 5-19 Reassembly Screw Down Sequence

8. Install the Audio PA clip to the corner of the chassis (per Figure 5-20) by applying downward, equal pressure to the side and main tab of the clip. Side pressure on the clip will negatively impact heat sinking of the 5 V Regulator and Audio PA. The placement tab should rest flush against the top of the chassis wall.

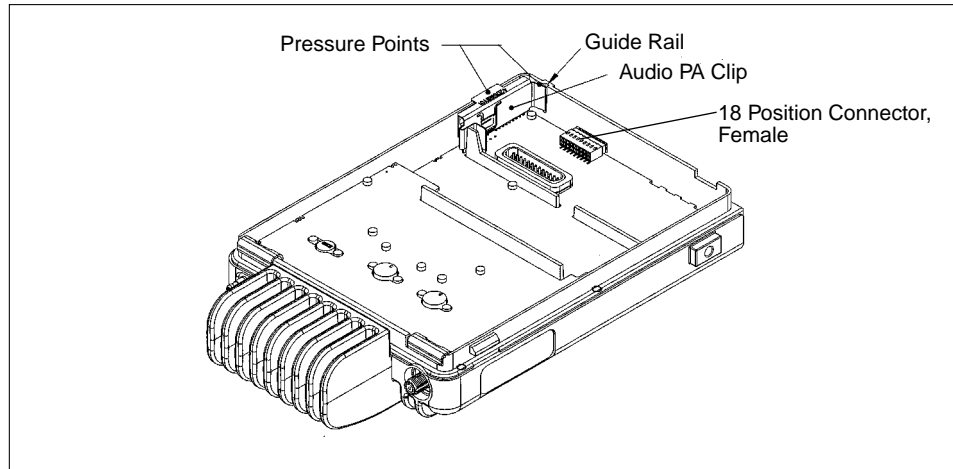

Figure 5-20 Inserting Audio PA Clip

9. Install the RF shield by placing it over the chassis with the front and back tabs inside the chassis and side tabs outside the chassis walls. Push straight down applying even pressure to the edges of the shield until they rest flush on the chassis wall. Repeat the same operation for the PA shield.
10. Insert the 18 position connector (black side) through the opening in the chassis into the female connector on the RF board.



The 18 position connector is not symmetrical, therefore the black side must mate to the connector on the transceiver board.

11. Place a new cover gasket around the chassis being sure it is placed under the locking tabs and the v-shaped rail shown in Figure 5-21. To ensure that the gasket remains seated under the rail, twist the gasket up and toward chassis between the fingers at the location of the lowest point of "V". Position the gasket under the rail and release.
12. Insert the 18 position connector (white side) into the female connector through the hole in the front of the chassis.
13. Carefully guide the bottom cover front hole opening over the 18 position connector. Engage the bottom cover over the hooks at the front of the chassis, rotate the cover back over the chassis, and press down until the sides snap into place.

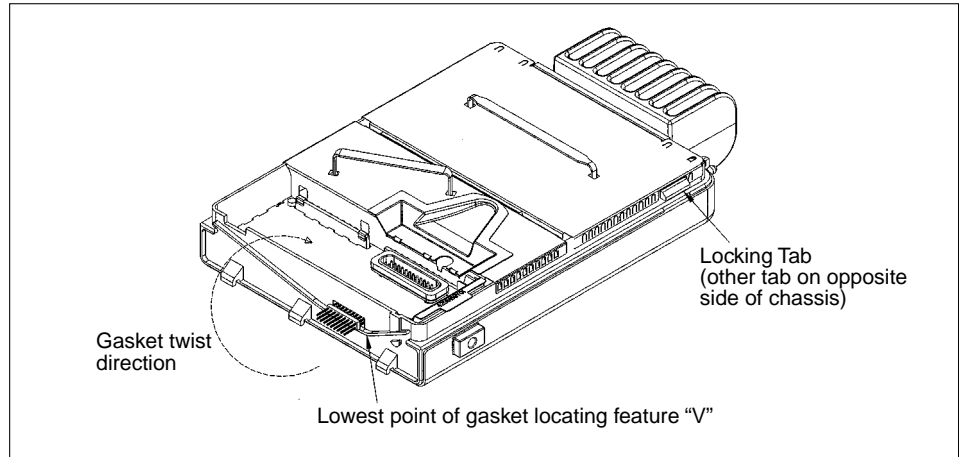

Figure 5-21 Installing Cover Gasket

14. Install the accessory connector assembly through the bottom side of the radio. Be sure to install the connector straight down into the unit because otherwise it will catch on the housing and no connection will be made.



The radio will not function without the accessory connector.

Replaceable Pushbuttons Replacement Procedure



Availability of replaceable pushbutton control heads depends upon date order was placed, shipped and based upon options ordered. Contact your Parts division for aftermarket kits and parts.

Models II & III

KEYPAD WITH REPLACEABLE PUSHBUTTONS

There are five sizes of replaceable pushbuttons, which are designated sizes A, B, C, and D. The locations and sizes of the Model I, II and III replaceable pushbuttons are shown in Figure 5-22, Figure 5-23 and Figure 5-24, respectively. All available replaceable pushbuttons, cross-referenced to their legend descriptions, colors, sizes and part numbers are listed in see Table 5-1 on page 523

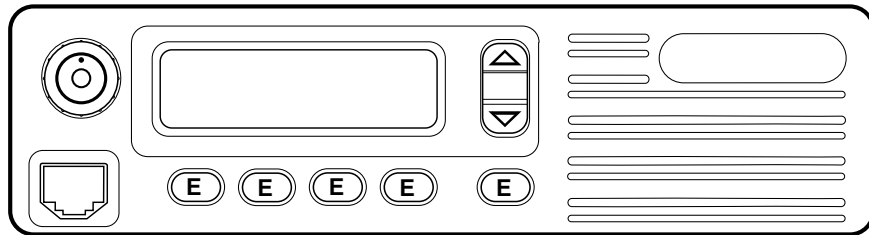

Figure 5-22 Model I Replaceable Pushbuttons

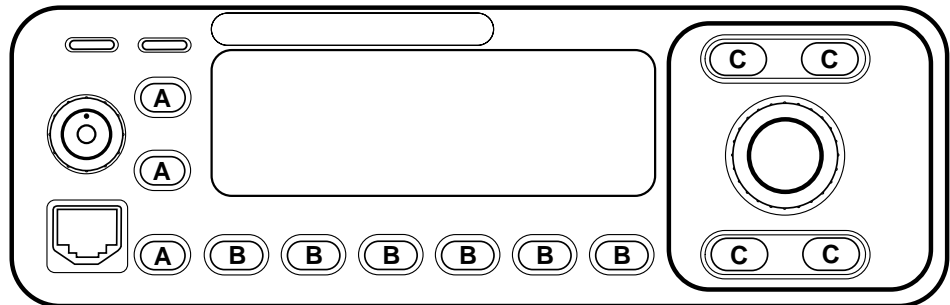

Figure 5-23 Model II Replaceable Pushbuttons

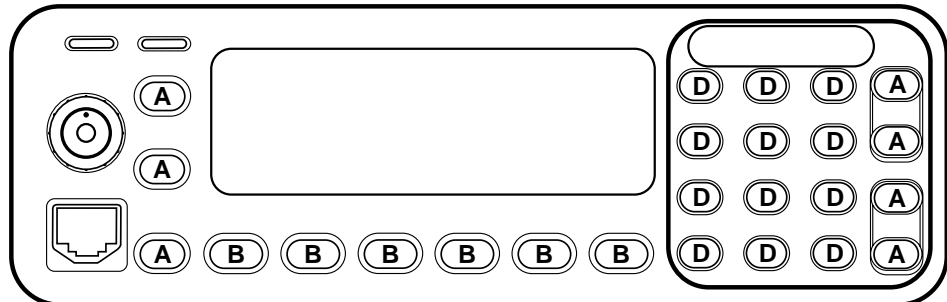

Figure 5-24 Model III Replaceable Pushbuttons

Replaceable pushbuttons can be replaced in two ways:

- while the control head is disassembled or
- while the control heads is assembled.

Replacement in Disassembled Control Head

To replace buttons in a control head that is already disassembled, follow the procedure below.

1. Pull replaceable pushbutton up and out of housing.
2. Replace buttons as necessary per Table 5-1, "Replaceable Pushbutton Graphics and Part Numbers," on page 5-23.
3. Place the keypad into the control head housing.
4. Snap the light pipe into the housing. Alternate engaging snaps on each side for best result.
5. Make sure that both the volume knob and potentiometer are both fully in the counter clockwise position before assembling the board into the housing.
6. Snap the board assembly into the housing.
7. For model "II" only, attach the large rotary knob.

Replacement in Assembled Control Head

To replace buttons in a control head that is already assembled, follow the procedure below:

The replaceable style pushbuttons have two expandable tabs on the inside edge, one on the top and one on the bottom. When expanded, these tabs press against the inside surface of the control head faceplate and hold the pushbutton in place. To replace a pushbutton, refer to Figure 5-25 and Figure 5-26 and proceed as follows:



Caution

Be careful to avoid damaging surface of control head front panel when using flat end pliers to grasp pushbutton to be removed.

1. Grasp pushbutton to be removed with flat end pliers (Motorola Part Number 6685629A01) as close as possible to control head faceplate.



Caution

In step 2 below, to avoid damage to pushbutton, compress pushbutton only enough to allow tabs on pushbutton to clear edges of hole in faceplate.

2. Compress pushbutton *just enough* so that the tabs can clear the control head faceplate. Then pull pushbutton away from control head.
3. Orient the new pushbutton so that legend is oriented correctly.



No tools are required to perform Step 4. below.

4. Snap replacement pushbutton into opening in control panel faceplate.

5. Verify that tabs on replacement pushbutton are engaged behind control head faceplate and that pushbutton operates freely.
6. Using RSS software and manual, reprogram the radio so that replaced pushbutton has the desired function.

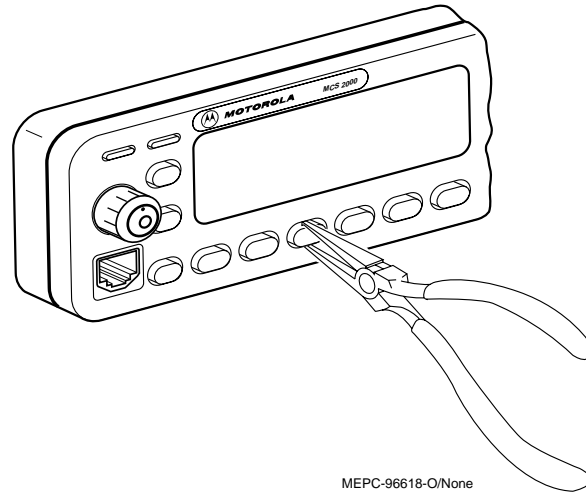

Figure 5-25 Grasping Pushbutton with Flat End Pliers

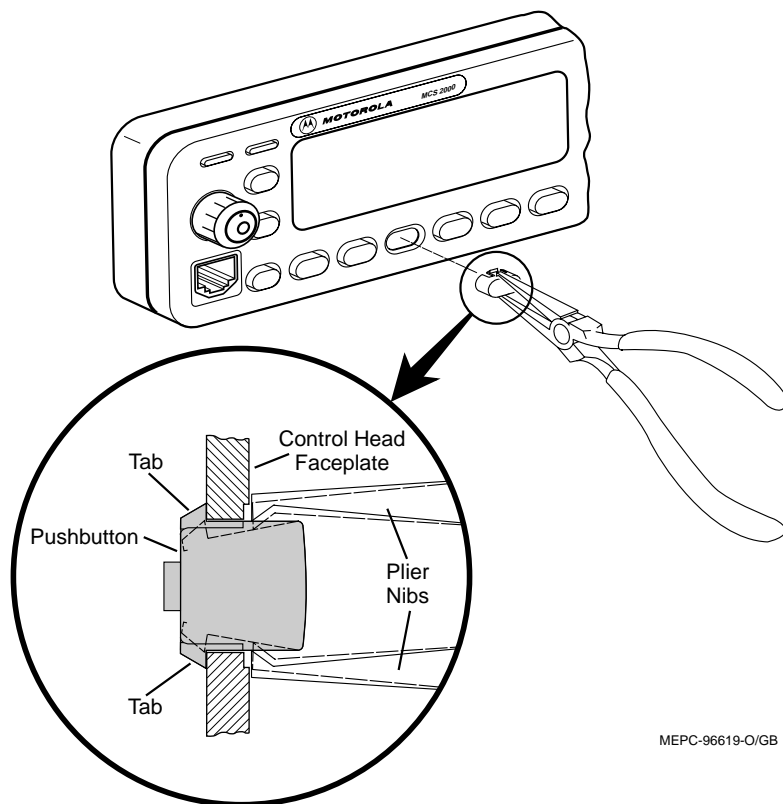

















Figure 5-26 Pulling Pushbutton Away from Control Head

Table 5-1 Replaceable Pushbutton Graphics and Part Numbers

Graphic			Pushbutton Part Number				
Legend	Description	Color	Size A	Size B	Size C	Size D	Size E
BLANK	Blank	White	3805230Z01	3805231Z01	3805232Z01	3805233Z01	3805234Z01
BLANK	Blank	Orange	3805230Z18	3805231Z14	3805232Z10	N/A	3805234Z10
A	A	Black	3805230Z42	3805231Z42	3805232Z42	N/A	3805234Z40
B	B	Black	3805230Z43	3805231Z43	3805232Z43	N/A	3805234Z41
C	C	Black	3805230Z44	3805231Z44	3805232Z44	N/A	3805234Z42
Call	Call	Black	3805230Z21	3805231Z07	3805232Z13	N/A	3805234Z13
D	D	Black	3805230Z45	3805231Z45	3805232Z45	N/A	3805234Z43
Del	Delete	Black	3805230Z35	3805231Z35	3805232Z35	N/A	3805234Z14
Dim	Dim	Black	3805230Z12	3805231Z17	3805232Z14	N/A	3805234Z15
Dir	Dir	Black	3805230Z38	3805231Z38	3805232Z38	N/A	3805234Z36
Emer	Emergency	White	3805230Z22	3805231Z09	3805232Z15	N/A	3805234Z16
Emer	Emergency	Orange	3805230Z20	3805231Z16	3805232Z12	N/A	3805234Z12
H/L	Horn/Light	Black	3805230Z23	3805231Z04	3805232Z16	N/A	3805234Z17
Home	Home	Black	3805230Z10	3805231Z18	3805232Z03	N/A	3805234Z18
Menu	Menu	Black	3805230Z09	3805231Z19	3805232Z04	N/A	3805234Z05
Mess	Message	Black	3805230Z46	3805231Z46	N/A	N/A	N/A
Mon	Monitor	Black	3805230Z33	3805231Z33	3805232Z33	N/A	3805234Z19
Mpl	Mpl	Black	3805230Z41	3805231Z41	3805232Z41	N/A	3805234Z39
Opt	Option	Black	3805230Z05	3805231Z20	3805232Z02	N/A	3805234Z20
Page	Page	Black	3805230Z03	3805231Z08	3805232Z17	N/A	3805234Z21
Phon	Phone	Black	3805230Z24	3805231Z05	3805232Z18	N/A	3805234Z22
Pwr	Power	Black	3805230Z39	3805231Z39	3805232Z39	N/A	3805234Z37
Read	Read	Black	3805230Z48	3805231Z48	N/A	N/A	N/A
Rcl	Recall	Black	3805230Z36	3805231Z36	3805232Z36	N/A	3805234Z34
S	Menu	Black	3805230Z16	3805231Z21	3805232Z06	N/A	3805234Z08
Scan	Scan	Black	3805230Z25	3805231Z06	3805232Z19	N/A	3805234Z23
Sec	Secure	Black	3805230Z34	3805231Z34	3805232Z34	N/A	3805234Z24
Sel	Select	Black	3805230Z08	3805231Z22	3805232Z05	N/A	3805234Z06
Site	Site	Black	3805230Z37	3805231Z37	3805232Z37	N/A	3805234Z35
Srch	Search	Black	3805230Z11	3805231Z23	3805232Z20	N/A	3805234Z25
Stat	Status	Black	3805230Z47	3805231Z47	N/A	N/A	N/A
Sys	System	Black	3805230Z40	3805231Z40	3805232Z40	N/A	3805234Z38
Zone	Zone	Black	3805230Z02	3805231Z24	3805232Z21	N/A	3805234Z26

Graphic			Pushbutton Part Number				
Legend	Description	Color	Size A	Size B	Size C	Size D	Size E
	Call Symbol	Black	3805230Z26	3805231Z13	3805232Z22	N/A	3805234Z07
	Emergency Symbol	White	3805230Z27	3805231Z02	3805232Z23	N/A	3805234Z02
	Emergency Symbol	Orange	3805230Z19	3805231Z15	3805232Z11	N/A	3805234Z11
	Horn/Light Symbol	Black	3805230Z28	3805231Z10	3805232Z24	N/A	3805234Z27
	Home Symbol	Black	3805230Z29	3805231Z25	3805232Z09	N/A	3805234Z28
	Monitor Symbol	Black	3805230Z04	3805231Z26	3805232Z25	N/A	3805234Z29
	Option Symbol	Black	3805230Z15	3805231Z27	3805232Z08	N/A	3805234Z30
	Page Symbol	Black	3805230Z14	3805231Z28	3805232Z26	N/A	3805234Z31
	Phone Symbol	Black	3805230Z30	3805231Z11	3805232Z27	N/A	3805234Z04
	Scan Symbol	Black	3805230Z31	3805231Z12	3805232Z28	N/A	3805234Z03
	Secure Symbol	Black	3805230Z32	3805231Z03	3805232Z29	N/A	3805234Z32
	Select Symbol	Black	3805230Z17	3805231Z29	3805232Z07	N/A	3805234Z09
	Up Arrow Symbol	Black	3805230Z06	3805231Z30	3805232Z30	N/A	N/A
	Down Arrow Symbol	Black	3805230Z07	3805231Z31	3805232Z31	N/A	N/A
	Zone Symbol	Black	3805230Z13	3805231Z32	3805232Z32	N/A	3805234Z33

Graphic			Pushbutton Part Number				
Legend	Description	Color	Size A	Size B	Size C	Size D	Size E
1	Decimal Number	Black	N/A	N/A	N/A	3805233Z02	N/A
2	Decimal Number	Black	N/A	N/A	N/A	3805233Z03	N/A
3	Decimal Number	Black	N/A	N/A	N/A	3805233Z04	N/A
4	Decimal Number	Black	N/A	N/A	N/A	3805233Z05	N/A
5	Decimal Number	Black	N/A	N/A	N/A	3805233Z06	N/A
6	Decimal Number	Black	N/A	N/A	N/A	3805233Z07	N/A
7	Decimal Number	Black	N/A	N/A	N/A	3805233Z08	N/A
8	Decimal Number	Black	N/A	N/A	N/A	3805233Z09	N/A
9	Decimal Number	Black	N/A	N/A	N/A	3805233Z10	N/A
*	Special Character	Black	N/A	N/A	N/A	3805233Z11	N/A
0	Decimal Number	Black	N/A	N/A	N/A	3805233Z12	N/A
#	Special Character	Black	N/A	N/A	N/A	3805233Z13	N/A
2ABC	Numeral-Letter	Black	N/A	N/A	N/A	3805233Z14	N/A
3DEF	Numeral-Letter	Black	N/A	N/A	N/A	3805233Z15	N/A
4GHI	Numeral-Letter	Black	N/A	N/A	N/A	3805233Z16	N/A
5JKL	Numeral-Letter	Black	N/A	N/A	N/A	3805233Z17	N/A
6MNO	Numeral-Letter	Black	N/A	N/A	N/A	3805233Z18	N/A
7PRS	Numeral-Letter	Black	N/A	N/A	N/A	3805233Z19	N/A
8TUV	Numeral-Letter	Black	N/A	N/A	N/A	3805233Z20	N/A
9WXY	Numeral-Letter	Black	N/A	N/A	N/A	3805233Z21	N/A

NOTES

Radio Tuning Procedure

General

An IBM PC (personal computer) and RSS (Radio Service Software) are required to align the radio. Refer to the applicable RSS Manual for installation, setup procedures for the software and minimum computer requirements.

To perform the alignment procedures, the radio must be connected to the PC, RIB (Radio Interface Box), and Test Set as shown in Figure 6-1.



Caution

The use of Mini UHF Adapters will have damaging effects on the RF Antenna Connector which might lead to radio failure.

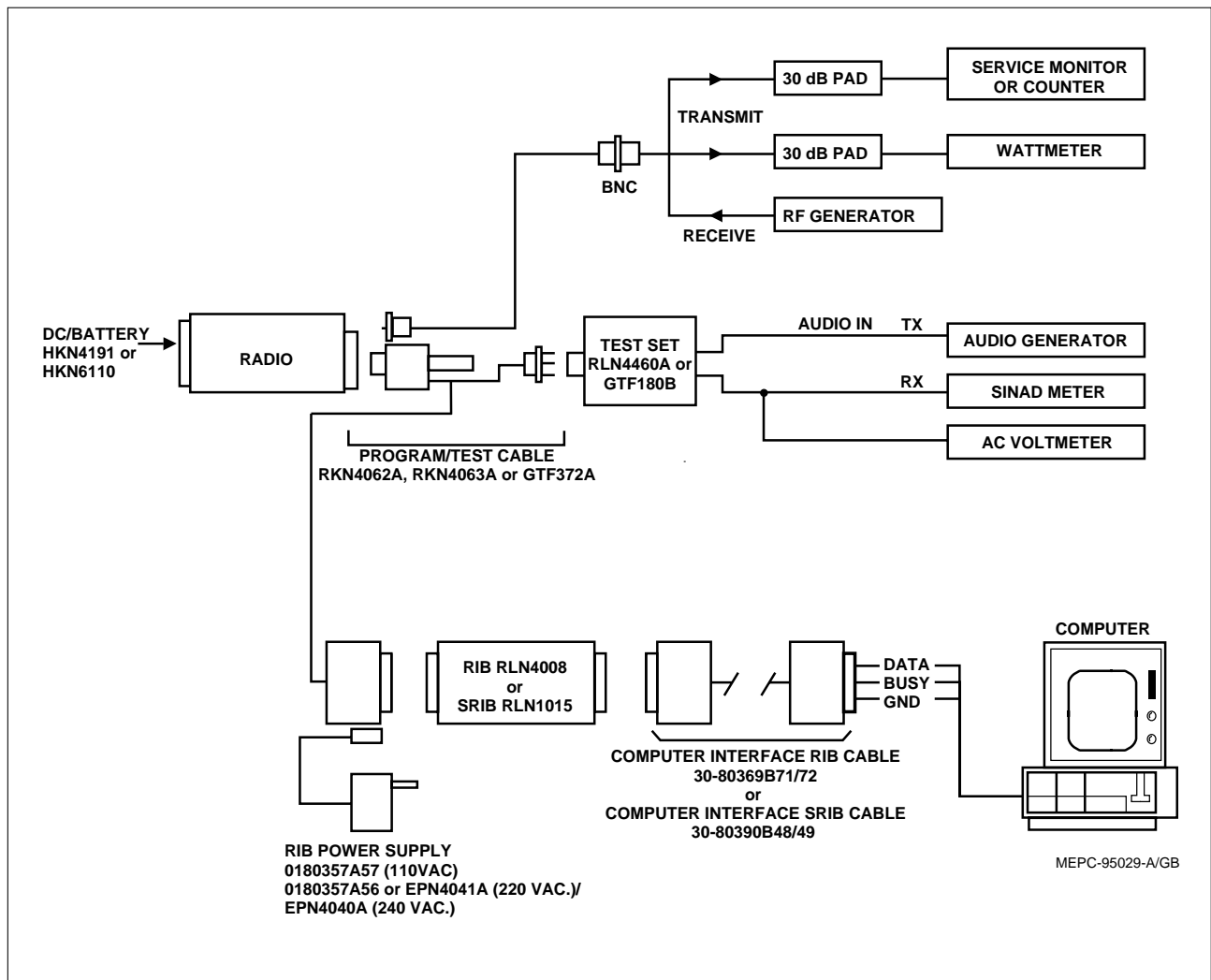

Figure 6-1 Radio Alignment Test Setup

As listed in the Service Aids table in Chapter 3 two different RSS packages are available for field programming of the MCS 2000 radios:

- RVN4113 for SmartNet/Zone, STARTSITE and Conventional StatAlert operation
- GVN6011 for Conventional Select 5 operation.

In RVN4113 all service and tuning procedures are performed from the SERVICE menu, which is selected by pressing F2 from the MAIN MENU. Figure 6-2 illustrates how the MCS 2000 RSS SERVICE screens are organized.

In GVN6011 all service and tuning procedures are performed from the TUNE RADIO menu which is entered by pressing F2, F5 from the MAIN MENU. The structure of the TUNE RADIO menu is the same one as shown for the SERVICE menu in RVN4113 illustrated in Figure 6-2.

The two RSS packages are very similar. The following tuning procedure is mainly described as seen from within the RVN4113 package.

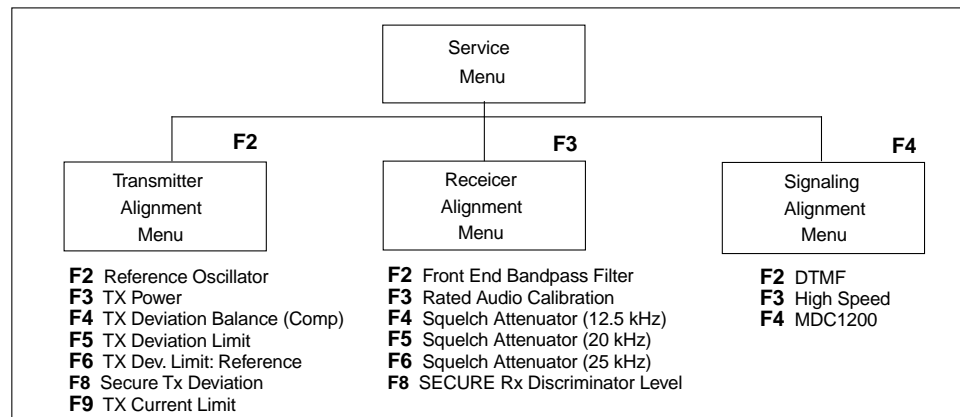

Figure 6-2 Service Menu Structure for RVN4113

Before going into the Service Aids menu, the radio must first be read using the GET/SAVE/PROGRAM Radio Data menu (if the radio has just been programmed with data loaded from disk or from a newly created codeplug, then it must still be read so that the RSS will have the radio's actual tuning values).

All SERVICE screens read and program the radio codeplug directly; you do NOT have to use the RSS GET/SAVE functions to program new tuning values.



Caution

Do NOT switch radios in the middle of any SERVICE procedure. Always use the EXIT key to return to the MAIN menu screen before disconnecting the radio. Improper exits from the SERVICE screens may leave the radio in an improperly configured state and result in seriously degraded radio or system performance.

The SERVICE screens use the concept of the "Softpot", an analog SOFTWARE controlled POTentiometer used for adjusting all transceiver alignment controls.

Each SERVICE screen provides the capability to increase or decrease the 'softpot' value with the keyboard UP/DOWN arrow keys respectively. A

graphical scale is displayed indicating the minimum, maximum, and proposed value of the softpot, as shown in Figure 6-3.

Adjusting the softpot value sends information to the radio to increase (or decrease) a DC voltage in the corresponding circuit. For example, pressing the UP arrow key at the Reference Oscillator screen instructs the radio microprocessor to decrease the voltage across a varactor in the reference oscillator, which decreases the frequency.

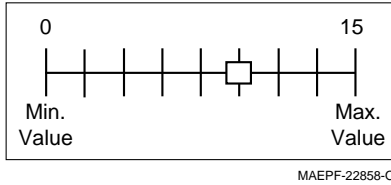

Figure 6-3 Softpot Concept

In ALL cases, the softpot value is just a relative number corresponding to a D/A (Digital-to-Analog) generated voltage in the radio.

Tuning Procedure



Perform the following procedures in the sequence indicated

Reference Oscillator Alignment

Adjustment of the reference oscillator is critical for proper radio operation. Improper adjustment will not only result in poor operation, but also a misaligned radio that will interfere with other users operating on adjacent channels. For this reason, the reference oscillator should be checked every time the radio is serviced. The frequency counter used for this procedure must have a stability of 0.1 ppm (or better).

1. From the SERVICE menu, press F2 to select TRANSMITTER alignment.
2. Press F2 again to select the REFERENCE OSCILLATOR softpot.
3. Press F6 to key the radio. The screen will indicate that the radio is transmitting.
4. Measure the transmit frequency on your frequency counter.
5. Use the UP/DOWN arrow keys to adjust the reference oscillator per the targets shown in Table 6-1.

Band	Target
VHF	±150 Hz
UHF	±150 Hz
800 MHz / 900 MHz	0.3 ppm

Table 6-1 Reference Oscillator Alignment

6. Press F6 again to dekey the radio and then press F8 to program the softpot value.
7. Press F10, F10 to return to SERVICE menu.

Transmitter Power

The radio requires two power level adjustments, a high power or rated power adjustment, and a low power adjustment.



- After POWER tuning, measure and note the DC current to the radio on each channel in the high power level. These values are needed for the Current Limit tuning.
- The larger the softpot values, the lower the transmit power.

Radio Model	Power Level	Test Frequency Range	Transmit Power Setting
VHF 25W	25 Watts	136-178 MHz	24-26 Watts
	5 Watts	136-174 MHz	5-7 Watts
VHF 110W R1	110 Watts	136-162 MHz	108-112 Watts
	55 Watts	136-162 MHz	53-57 Watts
VHF 110W R2	110 Watts	146-174 MHz	108-112 Watts
	55 Watts	146-174 MHz	53-57 Watts
UHF 25W	25 Watts	403-470 MHz	24-26 Watts
	10 Watts	403-470 MHz	9-11 Watts
UHF 10W	10 Watts	403-470 MHz	9-11 Watts
	5 Watts	403-470 MHz	5-7 Watts
UHF 40W	40 Watts	403-470 MHz	43-47 Watts
UHF 110W R1	110 Watts	403-470 MHz	108-112 Watts (98-103 Watts for test freq. F7)
	55 Watts	403-470 MHz	53-57 Watts
800 MHz 15W	15 Watts	806-870 MHz	16-18 Watts
	7.5 Watts	806-870 MHz	8-9.5 Watts
	3.75 Watts	806-870 MHz	4-5 Watts
800 MHz 35W	35 Watts	806-870 MHz	37.5-39.5 Watts for test freqs. F1-F3 33-34.4 Watts for test freqs. F4-F7
	17.5 Watts	806-870 MHz	19-20.5 Watts
	8.75 Watts	806-870 MHz	9-10 Watts
900 MHz 12W	13.5 Watts	896-941 MHz	13.5-15.5 Watts
	6.0 Watts	896-941 MHz	6.5-8 Watts
	3.5 Watts	896-941 MHz	3-4 Watts
900 MHz 30W	30 Watts	896-941 MHz	33-34.5 Watts
	6.0 Watts	896-941 MHz	8-9 Watts

Table 6-2 Transmit Power Setting

1. From the SERVICE menu, press F2 to select TRANSMITTER alignment.
2. Press F9 to select CURRENT LIMIT. Use the UP/DOWN arrow keys to set the softpot to zero. Press F8 to program the new value and press F10 to return to the TRANSMITTER alignment menu.
3. Press F3 to select the TRANSMIT POWER softpot. The screen will indicate the transmit test frequencies to be used.

Transmit Current Limit

4. Press F6 to key the radio, and use the UP/DOWN arrow keys to adjust the transmit power per the value shown in Table 6-2.
5. Press F6 to dekey the radio, and then press F8 to program the value. Press ENTER to select next softpot frequency.
6. Repeat steps 4 and 5 for the remaining test frequencies.
7. Press F10 to return to the TRANSMIT menu.



After POWER tuning, measure and note the DC current to the radio on each channel in the high power level. These values are needed for the Current Limit tuning.

Larger Softpot Values yield increased Cutback resulting in Lower Power.

For 800/900 MHz radios tuning is done with three voltages: 11.8 V, 13.8 V and 15.5 V.

1. Press F9 to select the Current Limit softpot. The screen will indicate the transmit test frequencies to be used.
2. Select the frequency with the highest DC current drain as measured during the power tuning procedure.
3. Press F6 to key the radio and use the UP/DOWN arrow keys to adjust the transmit Current Limit until the power has reached the maximum nominal power of the radio (10, 12, 15, 25, 30, 35, 40, 55 or 110 Watts). If the value cannot be exactly tuned set the output power one step above the nominal value.
4. Increase the current limit setting by number of steps defined in Table 6-3.
5. Press F6 to dekey the radio.
6. Press F8 to program the value. (The six other softpot values do not need tuning because only one Current Limit value is held in the radio).
7. Press F10 twice to return to the SERVICE menu.

Model	Power	Steps
VHF	all power levels	3
UHF	all power levels	0
800 MHz/900 MHz	all power levels	3

Table 6-3 Current Limit Step Adjustment

Transmit Deviation Balance (Compensation)

Compensation alignment balances the modulation sensitivity of the VCO and reference modulation (synthesizer low frequency port) lines. Compensation algorithm is critical to the operation of signaling schemes that have very low frequency components (e.g. DPL) and could result in distorted waveforms if improperly adjusted.

1. Press F4 to select the TRANSMIT DEVIATION BALANCE softpot. The screen will indicate the transmit test frequencies to be used.

2. Begin with the lowest test frequency shown on the screen.
3. With Test Box RLN4460A: Set the test box METER OUT switch to the AUDIO IN position, and inject a 80 Hz tone at 100 mVrms into the AUDIO IN BNC connector. To ensure proper signal level measure on METER OUT jack with AC voltmeter.
With Test Box GTF180B: Set the Test Box meter selector switch to the "GEN" position, and inject a 80 Hz tone at 100 mVrms into the "Audio In" port. Connect an AC meter to the meter port to ensure the proper input signal level.
4. Press F6 to key the radio, then press F8 and measure deviation. Record this measurement.
5. Press F6 again to dekey the radio, and change the input tone to 3 kHz, 100 mVrms.
6. Press F6 to key the radio, then press F8 and use the UP/DOWN arrow keys to adjust the deviation to within ± 0.15 kHz of the value recorded in Step 4.
7. Press F6 to dekey the radio, and press F8 to program the softpot value. Press ENTER to move to next softpot value.
8. Repeat steps 3 - 7 for the remaining test frequencies.
9. Press F10 to return to the TRANSMIT menu.



The step size change for step 6 is approximately 2.5% softpot value.

Transmit Deviation Limit

The transmit deviation limit softpot sets the maximum deviation of the carrier. Tuning is performed for 25 kHz channel spacing. Values for other channel spacings are calculated by the radio software.

1. Press F5 to select the TRANSMIT DEVIATION LIMIT softpot. The screen will indicate the transmit test frequencies to be used.
2. Begin with the lowest test frequency shown on the screen.
3. With Test Box RLN4460A: With the METER OUT switch set to MIC PORT, and METER OUT selector to MIC, inject a 1 kHz tone, 800 mVrms as measured on the AC/DC METER port.
With Test Box GTF180B: With the meter selector switch set to GEN, inject a 1 kHz tone, 800 mVrms as measured on the METER port. Where ever possible tune for the top of the range.
4. Press F6 to key the radio, and use the UP/DOWN arrow keys to adjust the deviation until 4.6 kHz is just exceeded, then step down 1 kHz.
5. Press F6 to dekey the radio, and press F8 to program the softpot value. Press ENTER to move to the next softpot value.
6. Repeat steps 3 - 5 for the remaining frequencies shown on the screen.
7. Press F10 to return to the TRANSMIT menu.



For SELECT 5 radios it is currently ESSENTIAL that the programming of the 25/30 kHz channel spacing is the last action before exiting this menu. The limit is 4.3 - 4.6 kHz, and although the softpot value will not normally need adjusting, the value must be programmed using the F8 key.

Transmit Deviation Limit Reference



This procedure is only required for VHF and UHF models with 20 kHz and 12.5 kHz channel spacing.

These softpots set the deviation reduction ratio to transmit at 20 kHz or 12.5 kHz channel spacing.

1. Press F6 to select the TRANSMIT DEVIATION LIMIT 12.5/20 kHz softpot.
2. With Test Box RLN4460A: With the meter selector switch set to MIC, inject a 1 kHz tone on the AUDIO IN terminal on the test set, 400 mVrms as measured on the AC/DC MTR port.
With Test Box GTF180B: With the meter selector switch set to GEN, inject a 1 kHz tone, 400 mVrms as measured on the METER port.
3. Press F6 to key the radio, then press F8 and use the UP/DOWN arrow keys to adjust the deviation until 4.6 kHz is just exceeded, then step down 1 kHz. Tune as close to the upper range as possible
4. Press F6 to dekey the radio, and press F8 to program the softpot value. Press Enter to move to next softpot value.
5. Repeat steps 2 - 4 for the remaining channel spacings.
6. Press F10 to return to the TRANSMIT menu.



For radios with Conventional Select 5 Signaling software it is currently ESSENTIAL that the programming of the 25/30 kHz channel spacing is the last action before exiting this menu. The limit is 4.3 - 4.6 kHz and although the softpot value will not normally need adjusting the value must be programmed using the F8 key.

Signaling Deviation



On radios with Conventional Select 5 Signaling software skip the next three steps and go to “DTMF Transmit Deviation (GVN6011 only)” on page 6-8 and “Select 5 Transmit Deviation (GVN6011 only)” on page 6-9.

DTMF Transmit Deviation

The DTMF Deviation Softpot is used to tune the FFSK signaling deviation.

1. From the SERVICE menu, press F4 to select SIGNALING alignment.
2. Press F2 again to select the DTMF softpot.
3. Press F6 to key the radio on the test frequency. The screen will indicate that the radio is transmitting.
4. Measure the DTMF deviation on your service monitor.
5. Use the UP/DOWN arrow keys to adjust the DTMF deviation per Table 6-4.

Channel Spacing (kHz)	DTMF	Trunking	MDC
25 / 30	3.05-3.40	2.5-3.5	3.25-3.75
20 (VHF/UHF)	2.44-2.76	2.0-2.8	2.6-3.0
12.5	1.55-1.85	1.25-1.75	1.62-1.88

Table 6-4 Signaling Deviation

6. Press F6 again to dekey the radio.
7. Press F8 to program the softpot value; press F10 twice to return to the SERVICE menu.

High Speed Deviation

1. From the SERVICE menu, press F4 to select SIGNALING alignment
2. Press F3 to select the TRUNKING HIGH SPEED softpot.
3. Press F6 to key the radio on the test frequency. The screen will indicate that the radio is transmitting.
4. Measure the TRUNKING HIGH SPEED deviation on your service monitor.
5. Use the UP/DOWN arrow keys to adjust the TRUNKING HIGH SPEED deviation per Table 6-4.
6. Press F6 again to dekey the radio.
7. Press F8 to program the softpot value; press F10 twice to return to the SERVICE menu.

MDC 1200 Deviation

1. From the SERVICE menu, press F4 to select SIGNALING alignment
2. Press F4 again to select the MDC softpot.
3. Press F6 to key the radio on the test frequency. The screen will indicate that the radio is transmitting.
4. Measure the MDC deviation on your service monitor.
5. Use the UP/DOWN arrow keys to adjust the MDC deviation per Table 6-4.
6. Press F6 again to dekey the radio.
7. Press F8 to program the softpot value; press F10 twice to return to the SERVICE menu.

DTMF Transmit Deviation (GVN6011 only)



This tuning sequence is **ONLY** for radios with Conventional Select 5 Signaling software being tuned with the RSS GVN6011.

The DTMF Deviation Softpot is used to tune the FFSK signaling deviation. Tuning is performed at one frequency and for 25 kHz channel spacing. The radio generates a DTMF signal for tuning. Values for other frequencies and channel spacings are calculated by the radio software.

1. From the RADIO TUNE menu, press F4 to select SIGNALING alignment.
2. Press F4 again to select the DTMF softpot.
3. Press F6 to key the radio on the test frequency. The screen will indicate that the radio is transmitting.
4. Measure the DTMF deviation on your service monitor.
5. Use the UP/DOWN arrow keys to adjust the DTMF deviation to be within 3.05 and 3.45 kHz.
6. Press F6 again to dekey the radio.
7. Press F8 to program the softpot value; press F10 to return to the SIGNALING menu.

Select 5 Transmit Deviation (GVN6011 only)



This tuning sequence is ONLY for radios with Conventional Select 5 Signaling software being tuned with the RSS GVN6011.

The Select 5 Deviation Softpot is used to tune the FFSK signaling deviation. Tuning is performed at one frequency and for 25 kHz channel spacing. The radio generates a Select 5 signal for tuning. Values for other frequencies and channel spacings are calculated by the radio software.



Alignment of the Transmit Deviation Limit Reference MUST immediately PRECEDE the Select 5 Alignment Procedure.

1. From the RADIO TUNE menu, press F4 to select SIGNALING alignment.
2. Press F5 again to select the Select 5 softpot.
3. Press F6 to key the radio on the test frequency. The screen will indicate that the radio is transmitting.
4. Measure the Select 5 deviation on your service monitor.
5. Use the UP/DOWN arrow keys to adjust the Select 5 deviation to be between 3.30 and 3.70 kHz.
6. Press F6 again to dekey the radio.
7. Press F8 to program the softpot value; press F10 twice to return to the SERVICE menu.

Squelch

The squelch softpots set the signal to noise ratio at which the squelch opens. The 25/30 kHz squelch value needs to be set at 7 frequencies across the frequency range. In 800 MHz and 900 MHz radios the 6th and 7th frequency are always the same, so only 6 frequencies are being tuned. For some models, the 20 kHz and 12.5 kHz values are then set at one frequency and the other frequency settings are calculated by the radio software. For other models the 20 kHz and 12.5 kHz squelch settings are also tuned for all 7 frequencies across the band.

1. From the SERVICE menu, press F3 to select RECEIVER alignment.
2. Channel spacing determines the next key press. Press F4, F5, or F6 (as applicable) to select the SQUELCH softpot.
3. Select the first test frequency shown, and adjust the UP/DOWN arrow key to the minimum squelch value.
4. With Test Box RLN4460A: Set the RF test generator to the test frequency plus the following offset: VHF: +200 Hz, UHF: +200 Hz, 800 MHz: +500 Hz.
With Test Box GTF180B: Set the RF test generator to the test frequency and modulate the signal generator at 3.0 kHz deviation, 1 kHz tone. Adjust the generator for an 8-10 dB SINAD level.
5. Adjust the UP/DOWN arrow key until the squelch just closes.
6. Monitor for squelch chatter; if chatter is present, repeat step 4.
7. When no chatter is detected, press F8 to program this value. Press "ENTER" to select next softpot adjustment.
8. Repeat steps 3 - 6 for all test frequencies shown on the screen.
9. Press F10, F10 to return to the Service menu.

Rated Audio

Alignment of the Rated Audio is not required on these radios.

Front-End Pre-
Selector

Alignment of the front-end pre-selector is not required on these radios.

Controller Section Theory of Operation

7

Introduction

The radio is a microcontroller-based dual mode (trunked/conventional) transceiver. The microcontroller determines the active state of the radio (transmit/receive), monitors radio status, and processes operator commands entered from the keypad or the other radio controls.

In the Low and Mid Power versions of the radio all radio circuitry is contained on a single rigid printed circuit board (PCB). In the High Power version of the radio, the physical arrangement of the circuitry is the same except the power amplifier (PA) part of the transmitter is contained on a separate PCB.

The radio is composed of the following three major functions:

- RF (Receiver and Transmitter)
- Controller (Main Controller and DC Power Control and Regulation)
- Control Head

The RF section is band specific circuitry described in one of the frequency range specific Volume 2s depending on the band split (See “Related Publications” on page 1-1).

The Control Head connects to the radio via an 18 pin connector. There are three different control head types of varying complexity: Model I, Model II and Model III. Control Head information is covered in this volume of the manual.

Theory Overview

The Controller section is physically separated into two functional sections, i.e. the Main Controller and the DC Power Control and Regulation.

The controller section of the radio is a microcomputer-based processor that controls the radio in accordance with its built in programming as well as commands input manually by the radio operator. The radio operator inputs manual commands to the controller section using the push-button and other controls located on the radio control head. In addition to its controlling functions, the controller section provides audio amplification of the audio output signal from the receiver section. It also controls and processes a squelch signal output from the receiver back end section to control the receiver's audio squelch function.

The radio controller consists of 5 main functional sections. These are:

- voltage regulation
- power control
- interfacing
- microprocessor operation
- audio and signalling processing

The controller is based on the Motorola 68HC11F1 microprocessor (U0103). In addition to the microprocessor, the controller has 3 external memory devices, signal MUX IC (U0105), and a Support Logic IC (SLIC IV, SLIC IVa, or SLIC V, U0104). The 3 memory devices consist of a 32 Kbyte EEPROM (U0100), 32 Kbyte SRAM (U0101), and a 256Kbyte or 1MByte FLASH EEPROM (U0102).

The digital section consists of a microprocessor, support memory, support logic, signal MUX ICs, the On/Off circuit, and General Purpose Input/Output circuitry.

Voltage Regulation

(Refer to schematic page 10-29 or 10-30 for reference)

Voltage Regulators

Voltage regulation for the controller is provided by 4 separate devices; U0500 (LM2925) +5V, U0501 (LM2941) +9.3 V, U0502 +8V, and UNSW 5V (a combination of R0004 and VR0001). Additional regulators are located in the RF section and the control head/handset.

Voltage regulation providing 5V for the digital circuitry is done by U500. Input and output capacitors (C0500/0501 and C0503/0504) are used to reduce high frequency noise and provide proper operation during battery transients. This regulator provides a reset output (pin 5) that goes to 0 volts if the regulator output goes out of regulation. This is used to reset the controller during power on to prevent improper operation. C0502 sets the duration of this reset signal to a minimum of about 12 ms.

Regulator U0501 is used to generate the 9.3 volts required by some audio circuits, the RF circuitry and power control circuitry. Input and output capacitors (C0505/0506 and C0508/0509) are used to reduce high frequency noise. R0503/R0504 sets the output voltage of the regulator. If the voltage at pin 1 is greater than 1.2 volts the regulator output decreases and if the voltage is less than 1.2 volts the regulator output increases. This regulator output is electronically enabled by a 0 volt signal on pin 2. Q0500 and associated circuitry (R0500/0501/0502 and C0507) are used to disable the regulator when the radio is turned off.

Regulated 8V is provided by U0502. It provides a separate supply to the microphone circuitry. The microphone cannot be supported directly from A+/SWB+ because any fluctuation on A+ would be impressed on the microphone line and affect transmitted audio. The microphone circuitry can not be connected to the other regulators because, there is a function which allows the radio to be switched on by momentarily grounding the microphone line (see Electronic On/Off).

UNSW 5V is only used in a few areas which draw low current and requires 5 V while the radio is off.

Electronic On/Off

Unlike older radios whose on/off feature was controlled only by the mechanical on/off switch, this radio has circuitry which allow radio software and/or external triggers to turn the radio on or off without direct user action. Some examples of this usage are 1) automatic turn on when emergency switch is engaged; 2) automatic turn on when ignition is sensed and off when ignition is off; 3) radio deaffiliation, with certain features the radio can be programmed to stay on for a brief period after the user has “turned it off”. During this “extra on” period the radio may transmit a signal to a base station letting the station know that the radio has been turned off.

Q0511 is used to provide SW B+ to the various radio circuits. Q0511 acts as an electronic on/off switch where pin 4 acts as the control pin. The switch is on when pin 4 is low and off when pin 4 is high. When the radio is off Q0510 is cutoff and the voltage at Q0511-4 is at A+. This effectively prevents current flow through Q0511 from pins 2/3 to 5/6/7/8. When the radio is turned on the voltage at the base of Q0510 is high (at least above 3V) and Q0510 switches on (saturation) and pulls down the voltage at Q0511-4 to ~0.07V. With FET Q0511 now “enabled” current flows through the device. This path has a very low impedance (less than 1 ohm) from pins 2/3 to 5/6/7/8. This effectively provides the same voltage level at SWB+ as at A+.

The electronic on/off circuitry can be enabled by the microprocessor, the emergency switch, the mechanical On/Off switch on the control head, or the ignition sense circuitry. If any of the 4 paths leading to the base of Q0510 provides a high voltage through diodes CR0510 or CR0511, the electronic “ON” is engaged.

Emergency

(Refer to schematic
Page 10-26 for
reference)

The emergency switch, when not engaged, normally grounds the base of Q0414. When the emergency switch is pressed this connection is opened and the base of Q0414 is pulled high by R0437. This causes the collector of transistor Q0414 to go low (.2V), thereby setting the EMERGENCY IN input of U0510 low. U0510 is a dual 555 timer configured as two “pulse stretchers”, one for the Emergency input to electronically turn on the radio and the other for the mechanical On/Off switch on the control head to cause the radio to electronically switch on.

With regard to emergency, when U0510-8 EMERGENCY IN is above 1/3 of the supply voltage at U0510-14, that causes the device to internally ground U0510-13, which in turn holds capacitor C0513 in a discharged state. The device also keeps U0510-9 EMER TRIG at a low voltage. When EMERGENCY IN goes below 1/3 of the device supply voltage, U0510 disables the discharge mechanism at pin 13 allowing the capacitor C0513 to charge through R0513. The charging rate is set by the values of R0513 and C0513. When the voltage at pin 12 goes above 2/3 supply voltage, the device sets pin 9 EMER TRIG high which in turn switches on Q0510 enabling the radio to turn on to begin emergency operation. U0510 will keep pin 12 high for a period set by R0513 and C0513 which for 200K/1 uF equals 220 ms.

While SW B+ is on for 220 ms, the microprocessor starts execution, reads that the emergency input is active, and sets the B+ CNTL output to a logic high. This high will keep Q0510 switched on through CR0510 beyond the 220 ms period after which U0510-9 will return to a low level. This operation allows a momentary press of the emergency switch to power up the radio. When the

microprocessor has finished processing the emergency press, it sets the B+ CNTL output to a logic 0. This turns off Q0511 and the radio turns off. Notice that EMER TRIG also goes to U0104-D5 and U0003-F2. This is where the appropriate microprocessor is alerted to the emergency condition. If the radio was already on when emergency was triggered then B+ CTRL would already be high and EMER TRIG going high due to the emergency condition would have no effect on Q0510, i.e. switching on Q0511 when it is already on.

Mechanical On/Off

(Refer to schematic Page 10-26 for reference)

This refers to the typical on/off switch, located on the control head, and which turns the radio on and off.

U0502 is fed by A+, and is therefore always on and providing 8 V on MIC VOLTAGE. When the Mechanical on/off switch is pressed, the MIC IN line is momentarily grounded setting the ON/OFF input of U0510-6 low.

Similar to the emergency operation described previously, when U0510-6 ON/OFF is above 1/3 of the supply voltage at U0510-14, it will cause the device to internally ground U0510-1, which in turn holds capacitor C0511 in a discharged state. The device also keeps U0510-5 SW B+ SENSE at a low voltage. When ON/OFF goes below 1/3 of the device supply voltage, U0510 disables the discharge mechanism at pin 1 allowing the capacitor C0511 to charge through R0512. The charging rate is set by the values of R0512 and C0511. When the voltage at pin 2 goes above 2/3 supply voltage, the device sets pin 5 SW B+ SENSE high which in turn switches on Q0510 enabling the radio to turn on to begin operation. U0510 will keep pin 5 high for a period set by R0512 and C0511 which for $200K/1 \mu F$ equals 220 ms.

While SW B+ SENSE is on for 220 ms, the microprocessor starts execution, reads that the SW B+ SENSE is active, and sets the B+ CNTL output to a logic high to keep Q0510 switched on through CR0510 beyond the 220 ms period. After this U0510-5 will return to a low level. This operation allows a momentary press of the Mechanical on/off switch to power up the radio. Notice that SW B+ SENSE also goes to U0104-B4 or U0003-H2. This is where the appropriate microprocessor is alerted to the turn on/off condition.

If the radio is already on when the switch was pressed then B+ CTRL is already high and SW B+ SENSE going high due to the switch being pressed will have no effect on Q0510. However, since SW B+ SENSE also goes to U0104-B4 or U0003-H2, the software can detect the line changing from low to high state momentarily, indicating that the radio must now turn off. In this case the software asserts B+ CTRL low which switches off Q0510 and Q0511, turning off the radio.

Resistor R0518 and capacitor C0518 form a filter to roll off any audio on the line. This prevents audio signal swing on the MIC IN line from triggering the on/off function at U0510-6.

Ignition

(Refer to schematic Page 10-29 for reference)

Ignition sense is used to prevent the radio from draining the vehicle's battery because the engine is not running. The radio can be programmed to keep the unit entirely off, preventing RX and TX; or programmed to only prevent TX, while the vehicle's engine is off. See for functional operation.

When the IGNITION input goes above 6 volts Q0430 turns on. This turns Q0517 off and turns Q0519 on, turning on SW B+ by directly forcing Q0511-4 low. The logic 0 output of Q0430 also turns on Q0431 providing an input to the microprocessor. The microprocessor starts execution, reads that the

Ignition input is active and sets the B+ CNTL output to a logic 1 to latch on SW B+. If the software determines that the radio should not be operating, it will set the CLEAR output to a logic 1 and the B+ CNTL output to a logic 0. This sets a latch composed of Q0514 - Q0517, R0519 and R0521. The latch output (at the collector of Q0517) will go to a logic 0 (at Q0517) and turn off Q0519, which allows R0514 to pull Q0511-4 high, switching the FET off. The latch output will remain at a logic 0 state until the IGNITION input has gone below 6 volts. The next time the IGNITION input goes above 6 volts the above process will be repeated. The microprocessor uses the ignition sense input along with codeplug data to determine if the radio is allowed to transmit.

Table 7-1 Conventional/MDC/SmartNet/SmartZone Ignition Sense Function - Operator Action vs Resultant Radio States

This Action During This State of Radio				Causes The Following Radio States to Occur			
Present State of Radio				Functions Available Through Ignition Sense Programmed in RSS			
Action	On/Off	Receive/Stand-by/Emergency	Ignition	Blank (Default from Factory ¹)	Soft Power Off Default from Factory	TX Inhibit	PTT Inhibit
Press On/Off Button	On	Receive/Stand-by	On	Off	Off	Off	Off
Press On/Off Button [†]	On	Emer	On	Off	Off	Off	Off
Press On/Off Button	Off	Off	On	On	On	On	On
Press On/Off Button	On	Receive/Stand-by	Off	Off	Off	Off	Off
Press On/Off Button	On	Emer	Off	Off	Off	Off	Off
Press On/Off Button	Off	Off	Off	On	On (Off [‡])	On - RX or Standby	On -RX or Standby
Short Press Emer Button	On	Receive/Stand-by	On	On - Emer TX	On - Emer TX	On - Emer TX	On - Emer TX
Long Press Emer Button	On	Emer	On	On	On	On	On
Short Press Emer Button ²	Off	Off	On	Off	Off	Off	Off
Short Press Emer Button ²	On	Receive/Stand-by	Off	On - Emer TX	Off	Emer Displayed for 3 Seconds then No Ack Displayed - No TX (All of the above plus sidetones ³)	On - Emer TX
Long Press Emer Button	On	Emer	Off	On	Off	On	On
Short Press Emer Button ²	Off	Off	Off	Off	Off	Off	Off
Turn Ignition On	On	Receive/Stand-by	Off	On	On	On	On - No PTT TX
Turn Ignition On ²	On	Emer	Off	On - Emer TX	On	On - Emer TX	On - Emer TX

This Action During This State of Radio				Causes The Following Radio States to Occur			
Present State of Radio				Functions Available Through Ignition Sense Programmed in RSS			
Action	On/Off	Receive/Stand-by/Emergency	Ignition	Blank (Default from Factory)	Soft Power Off Default from Factory	TX Inhibit	PTT Inhibit
Turn Ignition On	Off	Off	Off	Off	On	Off	Off
Turn Ignition Off	On	Receive/Stand-by	On	On	Off	On - No TX	On - No TX
Turn Ignition Off ²	On	Emer	On	On - Emer TX	Off	On - Emer TX	On - Emer TX
Turn Ignition Off	Off	Off	On	Off	Off	Off	Off
Data PTT	On	Data Mode	Off	TX	Off	No TX	No TX
Press On/Off Button	On	Data Mode	On	Off	Off	Off	Off
Press On/Off Button	On	Data Mode	Off	Off	Off	Off	Off
Short Press Emer Button	On	Data Mode	On	On - Emer TX	On - Emer TX	On - Emer TX	On - Emer TX
Short Press Emer Button ²	On	Data Mode	Off	On - Emer TX	Off	Emer Displayed for 3 Seconds then No Ack Displayed - No TX	On - Emer TX
Turn Ignition On	On	Data Mode	Off	On	N/A	On	On - No PTT TX
Turn Ignition Off	On	Data Mode	On	On	Off	On - No TX	On - No TX

* The "Default from Factory" was changed in Release 4.01.

† Take special note of Emergency operation (shown in oversize bold print) under these conditions.

‡ For firmware versions older than Release 4.0, the feature will operate as shown in parenthesis. To determine firmware version present in radio, proceed as follows:

Within 10 Seconds after powering on the radio, press the test mode entry button five times. On Model I radio, test mode entry button is third button from left on bottom row of buttons. On radio Models II and III, test mode entry button is first button on left side of bottom row of buttons. When the test mode entry button is pressed five times, the radio will scroll sequentially through six displays. The first display in the sequence is SERVICE. The second display is the radio firmware version (e.g., R03.11).

Power Control

(Refer to schematic
Page 10-20 for
reference)

The power control loop regulates power with an automatic level control (ALC) loop and provides protection features against overcurrent, excessive control voltage, and high operating temperatures. Power and current limit are adjusted under microprocessor control using a Digital to Analog (D/A) converter (U0551). Control voltage limit is set by resistor ratio on the transmitter, or D/A output for those radios that must minimize adjacent channel splatter. The D/A adjustable control voltage limit increases transmitter rise time and reduces adjacent channel splatter as it is adjusted closer to the actual operating control voltage.

The microprocessor controls K9.1 enable (K9.1 ENB) to bias the PA and antenna switch, PA disable (PA DIS) to disable the PA control voltage, and power range (PWR RANGE) to adjust the number of D/A steps per watt.



The Power Range Mode is not used on all models.

The ALC loop regulates power by adjusting the PA control line PA CNTL to keep the forward power voltage V FORWARD at a constant level. V FORWARD is amplified with a gain of set by the PWR RANGE signal (described below) and added to the PA PWR SET output U0551 pin 2 through resistors R0577, R0553 and R0554. The result is connected to opamp inverting input U0550 pin 9 which is compared with a 4.65 volt reference present at noninverting input U0550 pin 10. The 4.65 volt reference is set by a divider circuit connected to ground and 9.3 volts by resistors R0567 and R0569.

The power range line PWR RANGE controls the gain of the V FORWARD amplifier. For high power mode operation (i.e. VHF/UHF 110W models, high power mode is 110W. For VHF/UHF 40W models, high power mode is 40W) the PWR RANGE line is set to a logic 0 (<1.0V) and the resulting V FORWARD gain is $1+(R0564/R0573)$. For low power mode operation (i.e. VHF/UHF 110W models, low power mode is 50W. For VHF/UHF 40W models, low power mode is 25W) the PWR RANGE line is set to a logic 1 (>4.0V) and the resulting V FORWARD gain is $1+(R0564/RP)$ where RP equals R0563 in parallel with R0573.

The PA disable line PA DIS prevents transmitter operation by keeping the PA control voltage PA CNTL near zero volts. On radios that are required to minimize adjacent channel splatter, a control voltage limit line PA CNTL LIM is pulled to ground by transistor Q0556 when PA disable is high. This effectively makes the control voltage limit equal to zero and pulls the 4.65 volt reference at noninverting input U0550 pin 10 to ground through transistor Q0551. The ALC opamp output at U0550 pin 8 is prevented from rising above zero since the noninverting input is grounded. On radios that are not required to minimize adjacent channel splatter the transmitter is disabled through transistor Q0551 which pulls the PA control voltage PA CNTL directly to ground.

During normal transmitter operation the voltages at the opamp inputs U0550 pins 9 and 10 should be equal to 4.65 volts and the PA control voltage output at pin 8 should be between 4 and 7 volts. If power falls below the desired setting, V FORWARD decreases, causing the inverting input at U0550 pin 9 to decrease, increasing the opamp output at U0550 pin 8 and increasing the PA control voltage PA CNTL until V FORWARD increases to the desired level. The D/A output voltage PA PWR SET at U0551 pin 2 adjusts the power set point. V FORWARD reaches a steady state voltage such that the current through the R0554 branch equals the current through the R0553-R0577 branch. As PA PWR SET decreases, transmitted power must increase to make V FORWARD larger and keep the inverting input U0550 pin 9 at 4.65 volts.

Loop frequency response is controlled by opamp feedback components R0570 and C0568 and the output lowpass filter R0571 and C0569.

Rise and fall time is controlled by the D/A adjustable control voltage limit circuit attached to the reference voltage at U0550 pin 10 via transistor Q0555. The reference voltage at U0550 pin 10 is pulled low by Q0555 when the PA control voltage approaches the limit set by the D/A output PA CNTL LIM,

U0551 pin 13. The PA control voltage at U0550 pin 8 connects to opamp noninverting input U0202 pin 3 through the voltage divider formed by R0592 and R0591 and lowpass capacitor C0572. Control voltage limit is set by the D/A output PA CNTL LIM at U0551 pin 13 which connects to inverting input U0202 pin 2 through R0584, Q0556 and R0590. Transistor Q0556 is connected to the PA disable line, PA DIS which effectively pulls the control voltage limit to zero volts, and activates Q0555 to pull the reference voltage to zero when control voltage is greater than zero.

Protection features

The transmit power control circuit has three protection mechanisms. They are 1) thermal cutback, 2) current limit and 3) PA control voltage limit. These features operate by adding current to the ALC loop inverting input at U0550 pin 9 through diodes CR0550 and CR0551 and decreasing the PA control voltage. When the voltage exceeds 4.65 volts plus one diode drop at any cathode of diodes CR0550 and CR0551, current begins to flow into the ALC loop increasing the voltage at the inverting input U0550 pin 9. As a result the PA control voltage at U0550 pin 8 decreases in response to excessive PA control voltage, final device temperature, and final device current.

Thermal cutback limits the PA temperature by reducing the PA control voltage as temperature increases during extended periods of transmitter operation or high ambient temperatures.

PA TEMP connects to an inverting amplifier through resistor R0550 to inverting input U0550 pin 2. The noninverting input U0550 pin 3 is connected to a 4.65 volt reference formed by voltage divider resistors R0576 and R0582 which connect to ground and the 9.3 volt supply. The output of the inverting amplifier at U0550 pin 1 is the product of the amplifier gain as determined by the ratio of R0551 divided by R0550 and the difference between the amplifier inputs pins 2 and 3. When the PA TEMP input is greater than 4.65 volts the amplifier output is less than 5 volt.

As temperature rises the voltage on PA TEMP falls, the inverting amplifier output at U0550 pin 1 rises, current begins to flow through R0552 and CR0550 into the ALC loop at the inverting input of U0550 pin 9, decreasing the PA control voltage PA CNTL and reducing transmitter output.

Current limit is provided to protect the PA final device (Q5540) from overcurrent caused by low line voltage and/or mismatched antennas.

Voltage dividers on the current sense lines, CURRENT SENSE+/ CURRENT SENSE-, formed by resistors R0557, R0558, R0559, and R0560 protect the inputs of U0550 (pins 5 and 6) from excessive voltages. CURRENT SENSE+ connects to the noninverting input U0550 pin 5 through resistors R0557 and R0558. CURRENT SENSE- connects to the inverting input U0550 pin 6 through resistors R0559 and R0560. As current through the final device increases, voltage drop through R5612 increases and CURRENT SENSE- decreases with respect to CURRENT SENSE+, increasing the difference between inverting and noninverting inputs, causing the amplifier output at U0550 pin 7 to increase to over 4.65 volts plus one diode drop. As the amplifier output increases to over 5 volts, the current through resistor R0556 and diode CR0550 becomes sufficient to reduce the PA control voltage reducing the PA device current.

The D/A line CUR LIM SET at U0551 pin 4 adjusts the maximum allowed current by creating an offset voltage at the noninverting input U0550 pin 5

that is approximately equal to the voltage present at the inverting input during the maximum current voltage drop through R5612.

PA control voltage limit consists of a portion of the control voltage fed back to the power control loop. PA_CNTL_LIM is produced by a voltage divider network on the PA board. When PA_CNTL_LIM goes above the reference voltage of 4.65 V plus one diode voltage drop (i.e. 0.7 V) then protection begins. At this point the control voltage PA_CNTL is clamped. This protects the PA from being driven too hard by PA_CNTL which could cause excessively high output power

Interfacing

(Refer to "Clock Distribution Block Diagram" on page 7-10, and Interface schematic page 10-24 for general reference)

Microprocessor Clock Synthesizer

(Refer to ASFIC schematic page 10-23 for reference)

The clock source for the microprocessor system is generated by the ASFIC (U0200). Upon power-up the reference oscillator U5800 (Pendulum) provides a 16.8 MHz reference. Based on this reference the synthesizer (U5801) generates a 2.1 MHz waveform that is routed from the RF section (via C0403) to the ASFIC (on U0200-E1) and the option connectors (J0401-3 and J0408-3). At the option connectors the 2.1 MHz may be used as a reference for any option boards that are attached. For the main board controller the ASFIC uses 2.1 MHz as a reference input clock signal for its internal synthesizer. The ASFIC, in addition to audio circuitry, has a programmable synthesizer which can generate a synthesized signal ranging from 1200 Hz to 32.769 MHz in 1200 Hz steps.

When power is first applied, the ASFIC will generate its default 3.6864 MHz CMOS square wave μ P CLK (on U0200-D1) and this is routed to the microprocessor (U0103-36/U0003-E3) and SLIC (U0104-A3). After the microprocessor starts operation, it reprograms the ASFIC clock synthesizer to a higher μ P CLK frequency (usually 7.3728 or 14.7456 MHz) and continues operation.

The ASFIC synthesizer loop uses C0208, C0209 and R0204 to set the switching time and jitter of the clock output. If the synthesizer cannot generate the required clock frequency it will switch back to its default 3.6864 MHz output.

Because the ASFIC synthesizer and the μ P system will not operate without the 2.1 MHz reference clock it (and the voltage regulators) should be checked first in debugging the system.

Serial Peripheral Interface (SPI)

(Refer to Controller schematic page 10-19 for reference)

The μ P communicates to many of the ICs through its SPI port. This port consists of SPI TX DATA (U0103-66/U0003-B2), SPI RX DATA (U0103-65/U0003-B1), CLK (U0103-67/U0003-A2) and chip select lines going to the various ICs, connected on the SPI PORT (BUS). This BUS is a synchronous bus, in that the timing clock signal CLK is sent while SPI data (SPI TX DATA or SPI RX DATA) is sent. Therefore, whenever there is activity on either SPI TX DATA or SPI RX DATA there should be a uniform signal on CLK. The SPI TX DATA is used to send serial from a μ P to a device, and SPI RX DATA is used to send data from a device to a μ P.

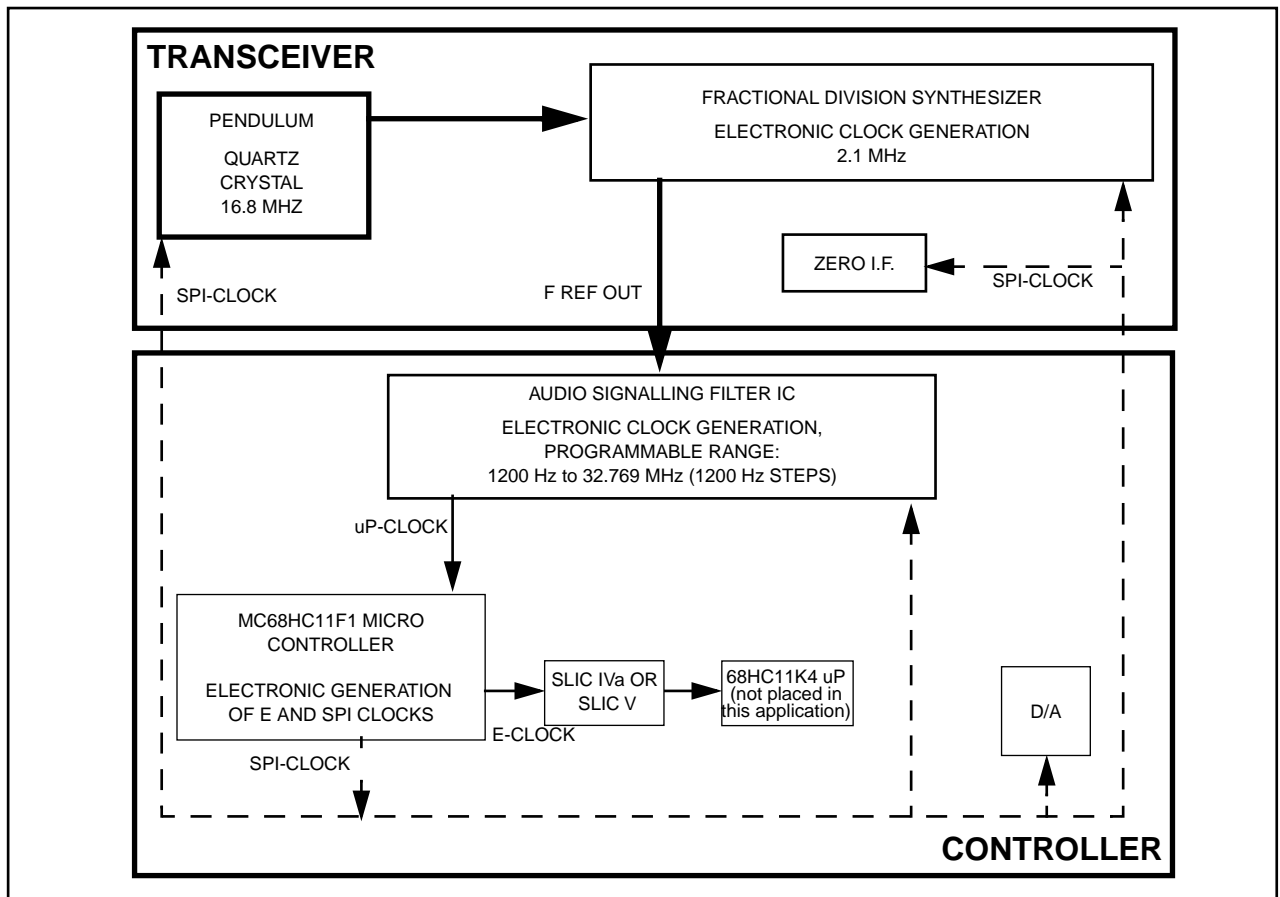

Figure 7-1 Clock Distribution Block Diagram

On the controller there are 2 ICs on the SPI BUS, ASFIC (U0200-F2) and D/A (U0551-6). In the UHF and VHF RF sections there are 3 ICs on the SPI BUS, ZIF (U3201-21), Pendulum (Reference Oscillator U5800-23) and FRAC/N (U5801-4). For the 800 and 900 MHz radios the 3 ICs on the SPI BUS are: ZIF (U6201), Pendulum (Reference Oscillator U6704) and FRAC/N (U6702). The SPI TX DATA and CLK lines going to the RF section are filtered by R0403 and R0404 to minimize noise.

There are 2 chip select lines going to each of the 2 Option boards (J0401-21 and J0401-23 /and J0408-21 and J0408-23).

When the μ P needs to program any of these ICs it brings the chip select line for that IC to a logic 0 and then sends the proper data and clock signals. The amount of data sent to the various ICs are different, for example the ASFIC can receive up to 21 bytes (168 bits) while the ZIF can receive up to 5 bytes (40 bits). After the data has been sent the chip select line is returned to a logic 1.

The Option board interfaces are different in that the μ P can also read data back from devices connected. Two additional interrupt lines are provided to each of the 2 option boards ASN INT (J0401-22 and J0408-22) and JABBA INT (J0401-20 J0408-20) are provided to allow an option to signal the μ P that there is data to transfer.

SB9600 Serial Interface

The timing and operation of this interface is specific to the option connected, but generally follows the pattern 1) an option board device generates the interrupt, 2) main board asserts a chip for that option board device, 3) the main board μ P generates the CLK, and 4) when data transfer is complete the main board terminates the chip select and CLK activity. Typical Data rate for the SPI BUS is 1 Megabit/sec.

(Refer to schematics on page 10-27 and 10-19 for reference and to SB9600 BUSY Simplified Schematic on page 9-27)

The SB9600 serial interface allows the radio to communicate with external radio options (like a control head) and Radio Service Software (RSS). This interface connects to both the Control Head connector (J0405) and the Accessory connector (J0403) and comprises BUS+ (J0405-15/J0403-6), BUS- (J0405-4/J0403-18), BUSY (J0405-14/J0403-5) and RESET (J0405-3/J0403-17). All of these lines are bidirectional, meaning that either the radio or an option can drive the line.

When the radio needs to send a message (for example to update the Control Head display) it first checks BUSY IN (U0103-76/U0003-A4) to make sure the interface is not currently being used. If this input is a logic 1 the interface is available and the μ P will change BUSY OUT (U0104-G4/U0003-29) to a logic 0. This drives the BUSY line to a logic 1 through buffer transistor Q0406 informing the radio and all connected devices that a data transmission is starting.

The radio's μ P then starts sending serial data on SCI TX (U0103-64/U0003- 83). This data is buffered by Q0402 and drives the differential bus signals (BUS+/BUS-) through Q0401 and Q0400. The BUS+ line normally sits at +5 volts because of pull-up resistor R0407. The BUS- line normally sits at 0 Volts because of pull-down resistor R0412.

While the radio is sending serial data on SCI TX it receives an "echo" of the same data on the SCI RX (U0103-63/U0003-82) line. The BUS-, BUS+ lines go to U0401 which acts as a comparator. When the BUS+ voltage is greater than the BUS- voltage the output (at U0401-7) is a logic 1. If it is less, the output is a logic 0. This is routed through U0105 to μ P (U0103). Note that the SCI SELECT input to U0105-11 is at a logic 1 to allow the routing to the controller on BUS SCI (U0105- 13).

A total of 5 bytes of data are sent for each standard message. After the data is sent the BUSY line is released to its default state (a logic 0). Other devices are now free to use the interface to send data.

The same method of operation occurs when an option sends data to the radio on this interface. The data is received through U0401 and U0105 (or R0020/R0021) to the SCI RX input of the μ P.

The sender receives back an "echo" of each byte and compares this to what was sent. If the echo does not agree then the transmission is repeated at a later time.

If excessive transmission errors occur, the μ P will reset the interface by setting the RESET OUT (U0104-B7/U0003-43) line to a logic 0. This drives the RESET line to a logic 1 through buffer transistor Q0408 resetting all SCI devices connected.

An option can reset the radio by driving the LH RESET line to a logic 1. This gets buffered by Q0409 and Q0425 and goes to the reset input of SLIC (U0104-A8). This then causes the reset input of the μ P (U0103-50) RESET to go to a logic 0 resulting in the μ P restarting operation.

General Purpose Input/Output

(Refer to IO Buffers schematic page 10-28 for reference)

Five general purpose I/O lines (GP I/O 2 through GP I/O 6) are provided to interface to external options. Each of these lines is configured under software control to be either an input or an “open collector” output. To make an I/O line an input the corresponding output line is set to a logic 0; for example to make GP I/O 6 (J0403-7) an input pin, OUT 6 (U0104-K8/U0003-24) is set to a logic 0. This turns off Q0423 and allows an external device to either turn on or off Q0424 which is sensed by U0104-H2/U0003-36 IN6/RTSB.

The GP I/O 2 line is different to the other 4 GP I/O lines. The output transistor (Q0425) can drive an external relay (HLN4435 or similar) for use with the vehicle horn or lights. This can also drive a non relay device, but the device must be designed to take a SW B+ input.

Selected GP I/O lines have secondary functions. If the line is used for the secondary function then it can not be used as an I/O line. The following secondary functions are supported (not all radio models support the RS-232 function, refer to the description for your radio).

Table 7-2 Secondary I/O Functions

I/O line	Standard	VRM500	VRM100	Alternate	Flashport
GP I/O 2	Horn/Lights	Horn/Lights	Horn/Lights	External Alarm Out	n/a
GP I/O 3	PTT	Data PTT	Data PTT	n/a	Bootstrap Vpp
GP I/O 4	Not Used	Not used	Data Mode Request (Modem)	RS-232 TX Data	Bootstrap Data
GP I/O 5	Car Radio Mute	Not used	Transmit Enable (Modem)	RS-232 CTS	n/a
GP I/O 6	Hub-Monitor	Not used	Channel Grant (Modem)	RS-232 RTS	n/a

The 470 pF and 10 nF capacitors serve to filter out any AC noise which may ride on the GPIO lines.

Microprocessor Operation

(Refer to schematic page 10-19 for reference)

For this radio, the μ P, U0103, is configured to operate in one of two modes, expanded and bootstrap. In expanded mode the μ P uses external memory devices to operate, whereas in bootstrap operation the μ P uses only its internal memory. In normal operation of the radio the μ P is operating in expanded mode as described below. See “Bootstrap Microprocessor Operation” on page 7-16 for bootstrap information.

Normal (=Expanded) Microprocessor Operation

In expanded mode on this radio, the μ P has access to 3 external memory devices; U0100 (EEPROM), U0101 (SRAM) U0102 (FLASH EEPROM). In addition the μ P has access to U0104 (SLIC). Also, within the μ P there are 1 Kbytes of internal RAM and 512 bytes of internal EEPROM, as well as logic to select external memory devices.

The external EEPROM (U0100) as well as the μ P's own internal EEPROM space contain the information in the radio which is customer specific, referred to as the codeplug. This information consists of items such as: 1)what band the radio operates in, 2)what frequencies are assigned to what channel, and 3) tuning information. In general, tuning information and other more frequently accessed items are stored in the internal EEPROM (space within the 68HC11F1), while the remaining data is stored in the external EEPROM. (See the particular device subsection for more details.)

The external SRAM (U0101) as well as the μ P's own internal RAM space are used for temporary calculations required by the software during execution. All of the data stored in both of these locations is lost when the radio powers off (See the particular device subsection for more details).

The FLASH EEPROM (U0102) contains the actual Radio Operating Software. This software is common to all radios within a given model type. For example Securenet radios may have a different version of software in the FLASH ROM than a non-secure radio (See the particular device subsection for more details).

The μ P provides an address bus of 16 address lines (A0-A15), and a data bus of 8 data lines (D0-D7). There are also 5 control lines; CSPROG (U0103-53), CSGEN (U0103-54), CSI01 (U0103-55), E CLK (U0103-34), and RWBIN (U0103-35). CSPROG and CSI01 are used to chip select the SLIC, CSGEN is used to chip select the SRAM. E CLK and RWBIN are used to generate the proper timed control signals to the memory devices. E CLK is generated by the microprocessor based on μ P CLK and is always 1/4 the frequency of μ P CLK, e.g. if μ P CLK is 7.3728 MHz, then E CLK will be 1.8432 MHz.

When the μ P is functioning normally, the address and data lines should be toggling at CMOS logic levels. Specifically, the logic high levels should be between 4.8 and 5.0 V, and the logic low levels should be between 0 and 0.2 V. No other intermediate levels should be observed, and the rise and fall times should be <30 ns.

The low-order address lines (A0-A4) and the data lines (D0-D7) should be toggling at a high rate, e. g., you should set your oscilloscope sweep to 1 us/ div. or faster to observe individual pulses. High speed CMOS transitions should also be observed on the μ P control lines.

On the μ P the lines XIRQ (U0103-51), BOOTSTRAP (U0103-58) and RESET (U0103-50) should be high at all times during normal operation. However, the XIRQ line is a non maskable interrupt and can be low during interrupt. Whenever a data or address line becomes open or shorted to an adjacent line, a common symptom is that the RESET line goes low periodically, with the period being in the order of 20 msec. In the case of shorted lines you may also detect the line periodically at an intermediate level, i.e. around 2.5 V when 2 shorted lines attempt to drive to opposite rails.

The MODA (U0103-33) and MODB (U0103-32) inputs to the μ P must be at a logic 1 for it to start executing correctly. After the μ P starts execution it will periodically pulse these lines. While the Central Processing Unit (CPU) is

running, this signal is an open-drain CMOS output which goes low whenever the μ P begins a new instruction (an instruction typically requires 2-4 external bus cycles, or memory fetches). However, since it is an open-drain output, the waveform rise assumes an exponential shape similar to an RC circuit.

There are 8 analog to digital converter ports (A/D) on U0103. They are labelled within the device block as PE0-PE7. These lines sense the voltage level ranging from 0 to 5 V of the input line and convert that level to a number ranging from 0 to 255 which can be read by the software to take appropriate action. For example U0103-23 is the battery voltage detect line. R0417 and R0416 form a resistor divider on SWB+. With 68K and 22K and a voltage range of 11 V to 17 V, that A/D port would see 2.68 V to 4.15 V which would then be converted to ~136 to 211 respectively.

U0103-30 is the high reference voltage for the A/D ports on the μ P. Resistor R0112 and capacitor C0104 filter the +5 V reference. If this voltage is lower than +5 V the A/D readings will be incorrect. Likewise U0103-29 is the low reference for the A/D ports. This line is normally tied to ground. If this line is not connected to ground, the A/D readings will be incorrect.

Capacitor C0105 serves to filter out any AC noise which may ride on +5V at U0103.

Support Logic IC (SLIC)

The SLIC (U0104) provides 3 primary functions, I/O port expansion, memory address expansion, and some signalling decoding.

There are 32 I/O lines within the SLIC which are under μ P control. They are grouped in 4 blocks of 8 and labelled as SLIC ports H, J, K, and L. Ports J, K, and L each have a DDR memory register and a "value" register. Port H only has a "value" register. These ports are accessed by the μ P by placing the correct address for the I/O registers on the address bus and either reading or writing the data on the data bus. Changing bits in the DDR registers configures specific port bits to be either input sensors or output drivers. The "value" registers either report the state of the sensed input or provide the logic level to be driven on a line configured as an output.

Since the 68HC11F1 only has 16 address lines (A0-A15), it can only directly address 64 Kbytes(=2¹⁶) of external memory. The radio architecture is designed to accommodate over 2 Mbytes of memory. The SLIC contains logic which allows addressing of the memory which would otherwise be unavailable to the μ P on its own. The SLIC monitors address lines A0, A1, A2, A3, A4, A14, and A15. Depending on what combinations appear on those lines, the SLIC may or may not assist the μ P with addressing. When the μ P is addressing a device on its own then address lines A0-A15 are used and valid. If instead the SLIC is assisting with the addressing then address lines A0-A13 from the μ P are valid, but the upper order address lines A14 OUT, A15 OUT, A16, A17, A18, and if necessary A19 are provided from the SLIC. There is no conflict with A14 and A14 OUT or with A15 and A15 OUT. Notice for example that SRAM U0101 uses A14 meaning that line is always provided from the μ P directly. Notice also that EEPROM U0100 and FLASH ROM U0102 use A14 OUT, meaning that their address lines come from the SLIC. On the SLIC itself, line A14 going to A14IN and A15 going to A15IN are address input lines TO the SLIC. Whereas A14 OUT and A15 OUT are address output lines FROM the SLIC.

The SLIC also generates chip select signals UV CS for U0102 and EE CS for U0101, as well as memory timing signals MEMRWB and OE.

The circuitry in the SLIC is reset when either the RESET IN (U0104-A8) is a logic 1, or RESET* (U0104-E4) is a logic 0, or PWR RST is a logic 0. These lines must be in the opposite logic state for the SLIC to function normally.

The SLIC supports hardware signalling decoding for certain signalling standards such as MPT 1327 and Trunking (OSW). There are different versions of SLIC each having a different decoder. Currently there are no SLIC devices which have more than 1 decoder.

The incoming data received by the radio and filtered by the ASFIC exits the ASFIC at U0200-G4 RX DATA, and enters the SLIC at U0104-B6. Based on the data the SLIC updates internal status registers which the μ P can read using the address and data bus, and act upon it.

Notice that RX data also goes to U0103-77/U0003-C5. This implies that the radio can be configured to perform software decoding if desired, even if the radio has a SLIC with a hardware decoder in it.

Capacitor C0108 serves to filter out any AC noise which may ride on +5V at U0104.

FLASH Electrically Erasable Programmable Memory (FLASH EEPROM)

The FLASH EEPROM (U0106) contains the radio's operating software. This software is common to all radios within a given model type. For example Securenet radios may have a different version of software in the FLASH ROM than a non-secure radio. This is, as opposed to the codeplug information stored in EEPROM (U0100) which could be different from one user to another in the same company.

In normal operating mode, this memory is only read, not written to. In bootstrap mode the Vpp pin (U0106-11) is brought to 12 V to allow the device to be written to. The memory access signals (UV CS, OE and MEMRWB) are generated by the SLIC. To upgrade/reprogram the FLASH software, the μ P must be set in bootstrap operating mode, and the FLASH device pin (U0106-11) Vpp must be between 11.4 and 12.6 V.

Taking diode CR0105 into account, the voltage at J0403-21 to enable FLASH programming may range between 12.1 and 13.1 V. Resistor divider pair R0104 and R0105 set up 4.1 V on U0106-11 which reduces the chance of logic transitions on I/O3 used as a GPIO from affecting the FLASH Vpp port. The FLASH device may be reprogrammed 1,000 times without issue. It is not recommended to reprogram the FLASH device at a temperature below 0°C.

(See "Bootstrap Microprocessor Operation" on page 7-16 for further details on reprogramming of the FLASH EEPROM)

Capacitor C0102 serves to filter out any AC noise which may ride on +5V at U0102, and C0107 filters out any AC noise on Vpp.

Electrically Erasable Programmable Memory (EEPROM)

The EEPROM (U0100) contains the radio's operating parameters such as operating frequency and signalling features, commonly known as the codeplug. It is also used to store radio operating state parameters such as current mode and volume. U0100 is a 32 Kbyte device. This memory can be written to in excess of 100,000 times and will retain the data when power is removed from the radio. The memory access signals (EE CS, OE and MEMRWB) are generated by the SLIC.

Additional EEPROM is contained in the μ P (U0103). This EEPROM is used to store radio tuning and alignment data. Like the external EEPROM this memory can be programmed multiple times and will retain the data when power is removed from the radio.

Note: the external EEPROM plus the 512 bytes of internal EEPROM in the 68HC11F1 comprise the complete codeplug.

Static Random Access Memory (SRAM)

The SRAM (U0101) contains temporary radio calculations or parameters that can change very frequently, and which are generated and stored by the software during its normal operation. The information is lost when the radio is turned off. The device allows an unlimited number of write cycles. SRAM accesses are indicated by the CSGEN signal U0101-20 (which comes from U0103-54) going low. U0101 is commonly referred to as the external RAM as opposed to the internal RAM which is the 1 K (1024) bytes of RAM which is part of the μ P. Both RAM spaces serve the purpose. However, the internal RAM is used for the calculated values which are accessed most often.

Resistors R0100, R0101, and R0102 allow the board to be configured to accept either an 8 K or 32 K byte EEPROM. For a 32 K device, R0100 is placed, and R0102 and R0101 are NOT placed. For an 8 K device R0100 is NOT placed, and R0102 and R0101 are placed.

Capacitor C0100 serves to filter out any ac noise which may ride on +5 V at U0101

Bootstrap Microprocessor Operation

The bootstrap mode of operation is only used to load new software into the FLASH EEPROM (U0106 or U0102). The MODA (U0103-33) and MODB (U0103-32) inputs must be a logic 0 when the microprocessor comes out of reset. The microprocessor will wait to receive data on its SCI RX (U0103-63) line and as data is received, it will be echoed on the SCI TX (U0103-64) line. For example, when the Smart RIB (SRIB) is used to load new software into the FLASH EEPROM, the signals to the microprocessor are automatically controlled by the SRIB to enter this mode. First the SRIB brings the SCI RX DATA (J0403-19) above 12 volts. This turns on dual transistor Q0103 to bring the MODA and MODB lines and the SCI SELECT line to a logic 0. The SRIB then releases the LH RESET (J0403-17) line and begins transferring the data to the radio. Data from the SRIB goes to GP I/O 4 (J0403-20) and data to the SRIB comes from the BUS+ and BUS- lines (J0403-6 and J0403-18). After an initial data transfer, the SRIB will bring the Vpp line (J0403-21) to 12.5 volts and start loading the data to be stored in the FLASH. The microprocessor will verify that each of the FLASH EEPROM memory locations are programmed correctly.

Audio and Signalling Circuits

(Refer to ASFIC schematic page 10-23 for reference)

Audio Signalling Filter IC (ASFIC)

The ASFIC has 4 functions;

1. RX/TX audio shaping, i.e. filtering, amplification, attenuation
2. RX/TX signalling, PL/DPL/HST/MDC/MPT
3. Squelch detection
4. Microprocessor clock signal generation (see Microprocessor Clock Synthesizer Description Block).

The ASFIC is programmable through the SPI BUS (U0200-E3/F1/F2), normally receiving 21 bytes. This programming sets up various paths within the ASFIC to route audio and/or signalling signals through the appropriate filtering, gain and attenuator blocks. The ASFIC also has 6 General Control Bits GCB0-5 which are CMOS level outputs. In this radio all, except GCB2 used for AUX TX IN2 (see Aux TX), are used to control the Hear Clear IC. (See Hear Clear Description Block for details).

Audio Ground

(Refer to schematic page 10-25 for reference)

VAG is the dc bias used as an audio ground for the op-amps that are external to the Audio Signalling Filter IC (ASFIC). U0201 forms this bias by dividing 9.3 V with R0206 and R0207 and buffering the 4.65 V result with a voltage follower. VAG emerges at pin 1 of U0201. C0235 is a bypass capacitor for VAG. The ASFIC generates its own 2.5 V bias for its internal circuitry. C0210 is the bypass for the ASFIC's audio ground dc bias. Note that while there are ASFIC VAG, BOARD VAG (U0201), and Hear Clear VAG, each of these are separate. They do not connect together.

Transmit Audio Circuits

(Refer to schematic page 10-23 for reference)

(Refer to Figure 7-2 for reference for the following sections)

The radio supports 2 distinct microphone paths known as internal and external mic. The microphones used for the radio require a DC biasing voltage provided by R0222 and R0223 for internal, and R0231 and R0230 for external. These two microphone audio input paths enter the ASFIC at U0200-A7 (external mic) and U0200-B8 (internal mic). Following the internal mic path; the microphone is plugged into the radio control head and is connected to the controller board via J0405-9.

From here the signal is routed to R0224. R0222 and R0223 provide the 9.3 VDC bias and R0224 provides input protection for the CMOS amplifier input. R0223 and C0219 provide a 560 ohm AC path to ground that sets the input impedance for the microphone and determines the gain based on the emitter resistor in the microphone's amplifier circuit.

Filter capacitor C0224 provides lowpass filtering to eliminate frequency components above 3 kHz, and C0218 serves as a DC blocking capacitor. C0427 bypasses RF interference which may couple onto the line to ground. The audio signal at U0200-B8 should be approximately 80 mV to achieve 60% of maximum system deviation.

The ASFIC has an internal AGC that can control the gain in the mic audio path. The AGC can be disabled/enabled by the μ P. Another feature that can be

enabled or disabled in the ASFIC is the VOX. This circuit, along with C0205, provides a DC voltage that can allow the μP to detect microphone audio. The ASFIC can also be programmed to route the microphone audio to the speaker for public address operation.

External Mic Path

The external microphone signal enters the radio on accessory connector J0403 pin 23. It is then routed to the ASFIC through resistor R0229 and capacitors C0223 and C0221, with DC bias provided by R0231/R0230

PTT Sensing and TX Audio Processing

Mic PTT is sensed via SB9600. An external PTT can be generated by programming one of the digital I/O lines on the accessory connector for PTT and grounding that pin. When microphone PTT is sensed, the μP will always configure the ASFIC for the "internal" mic audio path, and external PTT will result in the external mic audio path being selected.

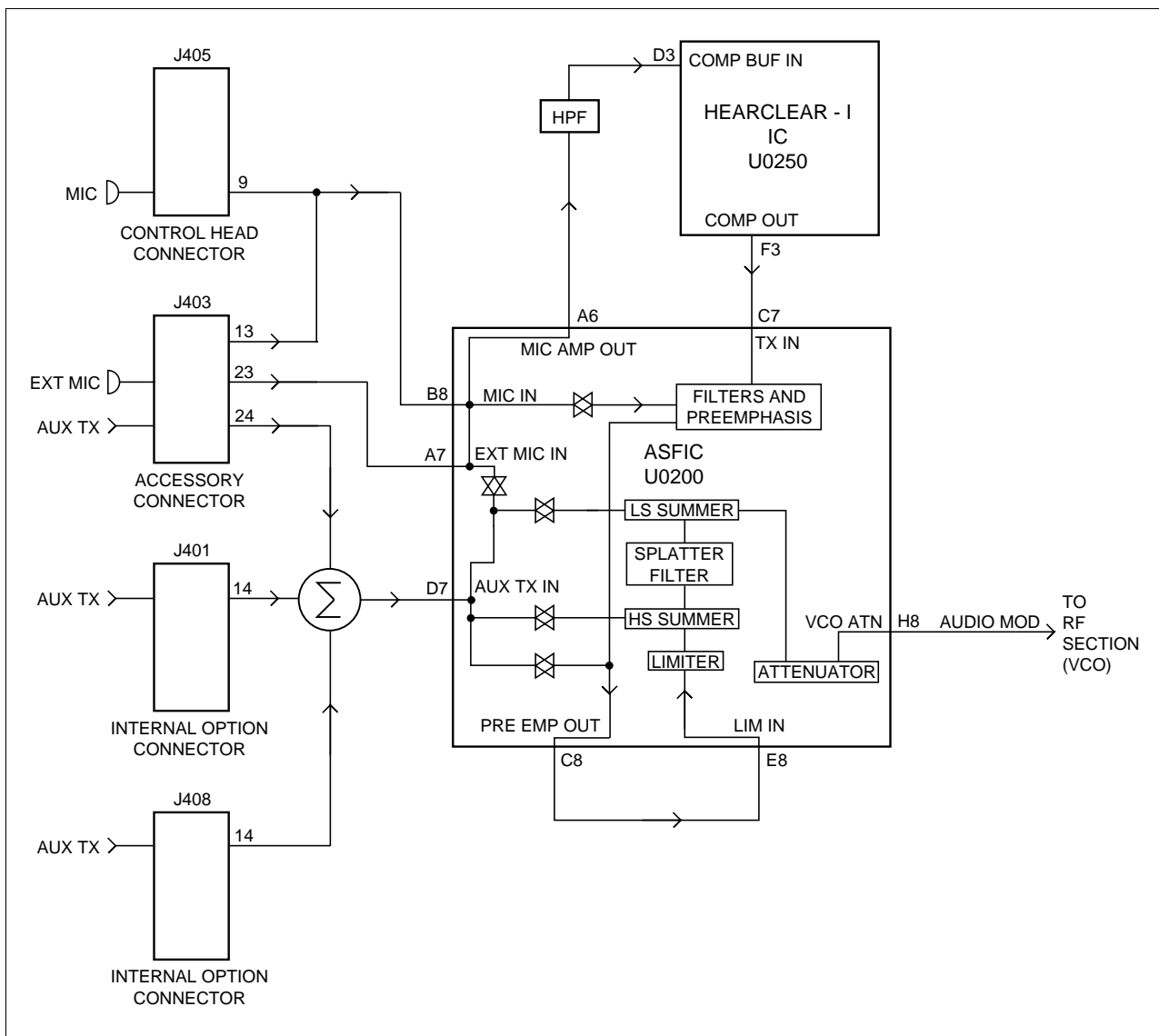

Figure 7-2 Transmit Audio Paths

Inside the ASFIC, the mic audio is filtered to eliminate components outside the 300-3000 Hz voice band, and pre-emphasized if pre-emphasis is enabled. The

capacitor between ASFIC pre-emphasis out U0200-C8 and ASFIC limiter in U0200-E8 AC couples the signal between ASFIC blocks and prevents the DC bias at the ASFIC output U0200-H8 from shifting when the ASFIC transmit circuits are powered up. The signal is then limited to prevent the transmitter from over deviating. The limited mic audio is then routed through a summer, used to add in signalling data, and then to a splatter filter to eliminate high frequency spectral components that could be generated by the limiter. The audio is then routed to two attenuators, which are tuned in the factory or the field to set the proper amount of FM deviation. The TX audio emerges from the ASFIC at U0200-H8 AUDIO MOD, at which point it is routed to the RF section.

Auxiliary TX Audio Paths

There are three auxiliary transmit audio inputs that are routed to the auxiliary transmit path in the ASFIC. These are AUX TX IN1, AUX TX IN2, and AUX TX IN3. The 3 paths, only one of which can be active at a time, are buffered by U0202.

AUX TX IN2 is special in that it can “change” input impedance. The “voltage mode” signal to U0400 is 9.3 V if the source for the auxiliary transmit audio from J0403 is a current source. The “voltage mode” signal is 0 V if the auxiliary transmit source is a voltage source. The difference being R0219 is bypassed by the transmission gate or not. Typically current source mode will apply for SB9600 based devices.

C0217 sets the lower frequency (high pass) signal of approximately 1 Hz. The processing of the signal on the auxiliary transmit path depends on how the ASFIC is configured. It can bypass filters, pre-emphasis, limiter, and/or splatter filter.

TX Secure Audio (AUX TX IN1 and AUX TX IN3)

The audio follows the normal transmit audio processing until it emerges from the ASFIC pre-emphasis out pin (U0200-C8), which is fed to the secure board residing at either option connector J0401-7 / J0403-7. The Secure board contains circuitry to amplify, digitize, encrypt, and filter the audio. The encrypted signal is then fed back from J0401-14 / J0408-14 to the AUX TX buffer through R0217 or R0218, and then to the ASFIC AUX TX input (U0200-D7). The signal level at this pin should be about 1 Vpp. The signal is then routed through the AUX TX path in the ASFIC (which bypasses everything before including the ASFIC splatter filter) and summed into the main modulation path. After the summer, it runs through the modulation attenuator and then to the AUDIO MOD port U0200-H8.

Transmit Signalling Circuits

(Refer to Figure 7-3 for reference for the following sections)

There are four types of transmit data:

1. Sub-audible data (PL/DPL/Connect Tone) that gets summed with transmit voice or signalling,
2. High speed (3600 baud) data for trunking control channel communication
3. DTMF data for telephone communication in trunked and conventional systems, and
4. MDC data for use in Motorola proprietary MDC systems. Select 5 and MPT-1327 signalling can be supported by the MDC signaling hardware.

Sub-audible Data (PL/DPL)

Sub-audible data implies signalling whose bandwidth is below 300 Hz. PL and DPL waveforms are used for conventional operation and connect tones for trunked voice channel operation. The trunking connect tone is simply a PL tone at a higher deviation level than PL in a conventional system. Although it is referred to as “sub-audible data,” the actual frequency spectrum of these waveforms may be as high as 250 Hz, which is audible to the human ear. However, the radio receiver filters out any audio below 300 Hz, so these tones are never heard in the actual system.

Only one type of sub-audible data can be generated by U0200 at any one time. The process is as follows, using the SPI BUS, the μ P programs the ASFIC (U0200) to set up the proper low-speed data deviation and select the PL or DPL filters. The μ P then generates a square wave which strobes the ASFIC PL/DPL encode input PL CLK U0200-C3 at twelve times the desired data rate. For example, for a PL frequency of 103 Hz, the frequency of the square wave would be 1236 Hz.

This drives a tone generator inside U0200 which generates a staircase approximation to a PL sine wave or DPL data pattern. This internal waveform is then lowpass filtered and summed with voice or data. The resulting summed waveform then appears on U0200-H8 (AUDIO MOD), where it is sent to the RF board as previously described for transmit audio. A trunking connect tone would be generated in the same manner as a PL tone.

High Speed Data

High speed data refers to the 3600 baud data waveforms, known as Inbound Signalling Words (ISWs) used in a trunking system for high speed communication between the central controller and the radio. To generate an ISW, the μ P first programs the ASFIC (U0200) to the proper filter and gain settings. It then begins strobing U0200-G1 (TX DATA) with a pulse

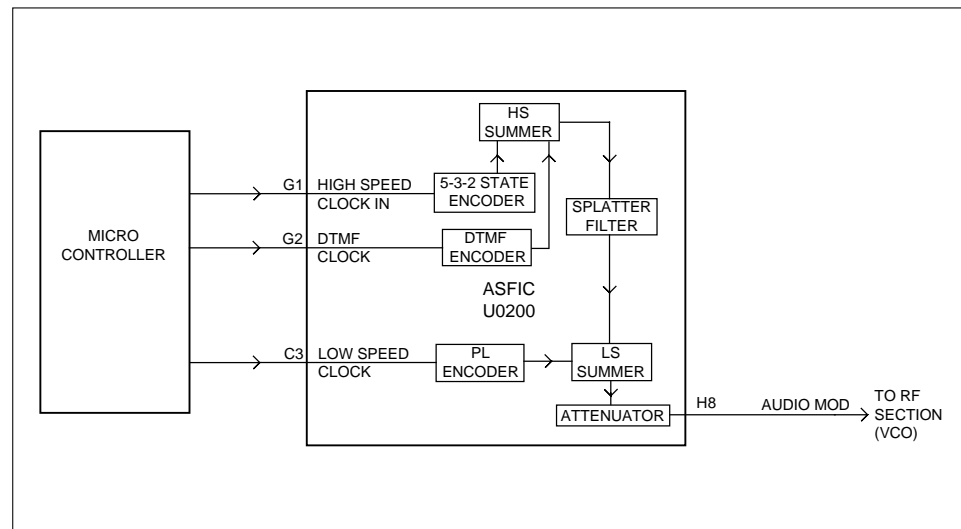

Figure 7-3 Transmit Signalling Paths

when the data is supposed to change states. U0200's 5-3-2 State Encoder (which is in a 2-state mode) is then fed to the post-limiter summer block and then the splatter filter. From that point it is routed through the modulation attenuators and then out of the ASFIC to the RF board. MPT 1327 and MDC are generated in much the same way as Trunking ISW. However, in some cases

these signals may also pass through a data pre-emphasis block in the ASFIC. Also these signalling schemes are based on sending a combination of 1200 Hz and 1800 Hz tones only. Microphone audio is muted during High Speed Data signalling.

Dual Tone Multiple Frequency (DTMF) Data

DTMF data is a dual tone waveform used during phone interconnect operation. It is the same type of tones which are heard when using a “Touch Tone” telephone.

There are seven frequencies, with four in the low group (697, 770, 852, 941 Hz) and three in the high group (1209, 1336, 1477 Hz).

The high-group tone is generated by the μ P (U0103-74 /U0003-B4) strobing U0200-G1 at six times the tone frequency for tones less than 1440 Hz or twice the frequency for tones greater than 1440 Hz. The low group tone is generated by the μ P (U0103-73/U0003-C4) strobing U0200-G2 (DTMF CLOCK) at six times the tone frequency. Inside U0200 the low-group and high-group tones are summed (with the amplitude of the high group tone being approximately 2 dB greater than that of the low group tone) and then pre-emphasized before being routed to the summer and splatter filter. The DTMF waveform then follows the same path as was described for high-speed data.

MDC Data

The MDC signal follows exactly the same path as the DTMF high group tone. MDC data utilizes MSK modulation, in which a logic zero is represented by one cycle of a 1200 Hz, and a logic one by 1.5 cycles of an 1800 Hz. To generate the data, the microcontroller first programs the ASFIC (U0200) with TXSG1 and TXSG0 control lines to the proper filter and gain settings. It then begins strobing U0200/Trunking Clock In with a pulse every time there should be a transition in the MDC waveform. The output waveform from U0200's 5-3-2 State Encoder is then fed to the post-limiter summer block and then the splatter filter. From that point it is routed through the modulation attenuators and then out of the ASFIC to the RF board. Microphone audio is muted during MDC signalling.

Receive Audio Circuits

(Refer to Figure 7-4 for reference for the following sections)

Squelch Detect

The radio's RF circuits are constantly producing an output at the discriminator. In addition to the raw discriminator signal DISC (IF1-3-2-1), the RF board's Zero IF IC also provides a separate buffered version of the discriminator signal that is dedicated to the ASFIC's squelch detect circuitry SQUELCH (IF1-2-17-1). This signal enters the controller board and is routed to the ASFIC on U0200-H7. All of the squelch detect circuitry is contained within the ASFIC. Therefore from a user's point of view, SQUELCH enters the ASFIC, and the ASFIC produces to CMOS logic outputs based on the result. They are CH ACT (U0200-H1) and SQ DET (U0200-H1).

The squelch signal entering the ASFIC is amplified, filtered, attenuated, and rectified. It is then sent to a comparator to produce an active high signal on CH ACT. A squelch tail circuit is used to produce SQ DET (U0200-H1) from CH ACT. The state of CH ACT and SQ DET is high (logic 1) when carrier is detected, otherwise low (logic 0). Both CH ACT and SQ DET are routed to the SLIC (U0104-F4/H1).

SQ DET is used to determine all audio mute/unmute decisions except for Conventional Scan. In this case CH ACT is a pre-indicator as it occurs slightly faster than SQ DET.

Audio Processing and Digital Volume Control

The signal enters the controller section from the ZIF on DISC (IF1-3-2-1) and passes through RC filter R0245 and C0236 which filters out ZIF sampling noise. The signal is AC coupled by C0202 and enters the ASFIC via the PL IN pin U0200-J7. Inside the IC, the signal goes through 2 paths in parallel.

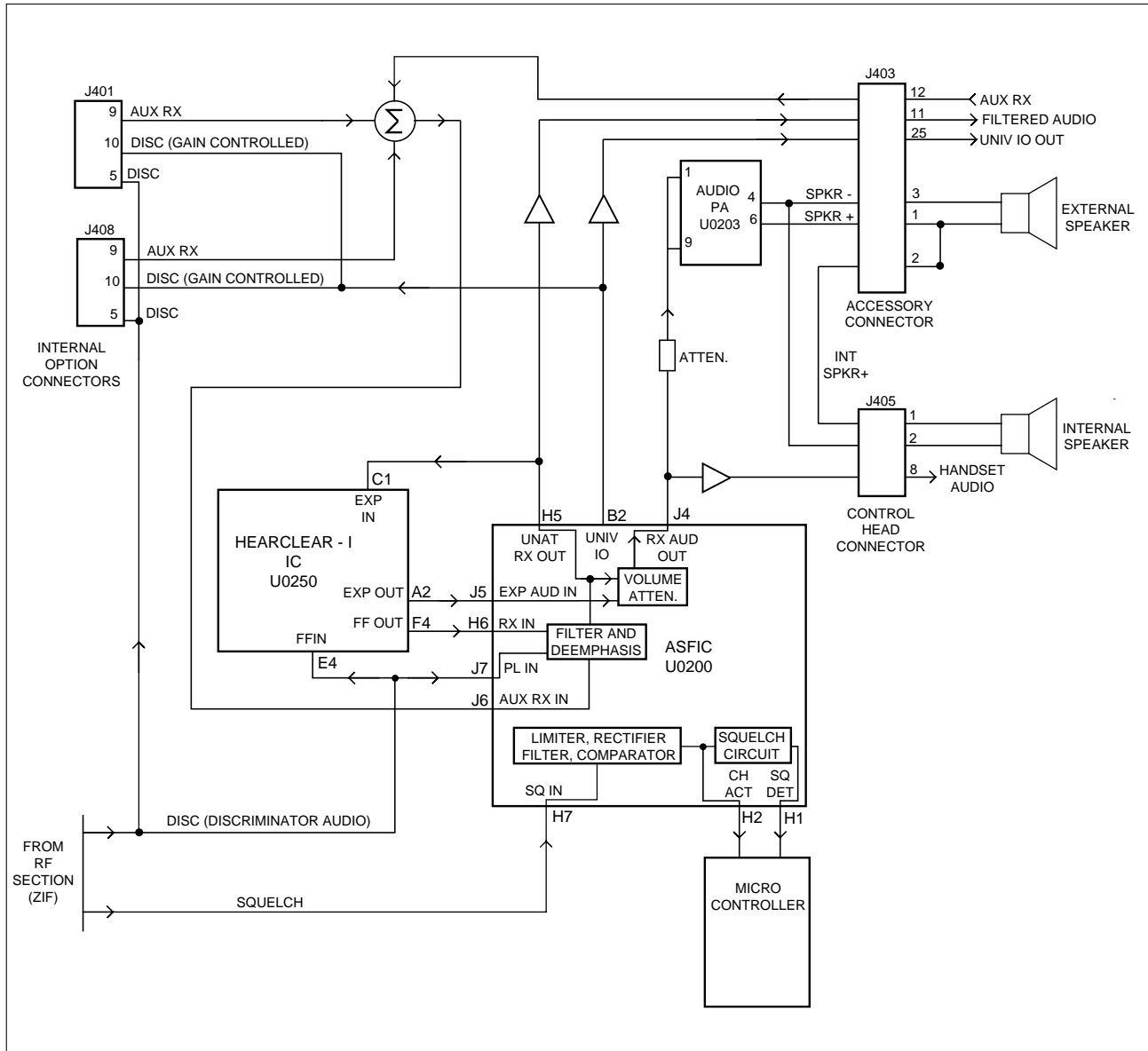

Figure 7-4 Receive Audio Paths

The audio path has a programmable amplifier, whose setting is based on the channel bandwidth being received, then a LPF filter to remove any frequency components above 3000 Hz and then an HPF to strip off any sub-audible data below 300 Hz. Next, the recovered audio passes through a de-emphasis filter if it is enabled (to compensate for Pre-emphasis which is used to reduce the effects of FM noise). The IC then passes the audio through the 8-bit

programmable attenuator whose level is set depending on the value of the volume control. Finally the filtered audio signal passes through an output buffer within the ASFIC. The audio signal exits the ASFIC at RX AUDIO (U0200-J4).

The μ P programs the attenuator, using the SPI BUS, based on SB9600 messages from the control head. The minimum /maximum settings of the attenuator are set by codeplug parameters.

Since sub-audible signalling is summed with voice information on transmit, it must be separated from the voice information before processing. Any sub-audible signalling enters the ASFIC from the ZIF at PL IN U0200-J7. Once inside it goes through the PL/DPL path. The signal first passes through one of 2 low pass filters, either PL low pass filter or DPL/LST low pass filter. Either signal is then filtered and goes through a limiter and exits the ASFIC as PL RX (U0200-A4). At this point the signal will appear as a square wave version of the sub-audible signal which the radio received. This signal then goes to the SLIC (U0104-E7). The SLIC must be poled periodically by the microprocessor to determine the state of bit 0 for port L (see SLIC description block for details). The microprocessor will then use that information to decode the signal.

Note these paths are somewhat different for radios using Hear Clear (See Hear Clear description block for details).

Audio
Amplification
Speaker (+) / (-)
(Refer to schematic
page 10-29 for
reference)

The output of the ASFIC's digital volume pot, U0204-J4 is routed through a voltage divider formed by R0234 and R0235 to set the correct input level to the audio PA (U0203). This is necessary because the gain of the audio PA is 46 dB, and the ASFIC output is capable of overdriving the PA unless the maximum volume is limited.

The audio then passes through C0240 which provides AC coupling and low frequency roll-off. C0242 provides high frequency roll-off as the audio signal is routed to pins 1 and 9 of the audio power amplifier U0203.

The audio power amplifier has one inverted and one non-inverted output that produces the differential audio output SPK+/SPK- (U0203-4/6). The inputs for each of these amplifiers are pins 1 and 9 respectively; these inputs are both tied to the received audio. The audio PA's DC biases are not activated until the audio PA is enabled at pin 8.

The audio PA is enabled via AUPA EN signal from the SLIC (U0104-F7). When the base of Q0200 is low, the transistor is off and U0203-8 is high, using pull up resistor R0236 — Audio PA is ON. The U0203-8 must be above 8.5 VDC to properly enable the device. If the voltage is between 3.3 and 6.4 V, the device will be active but has its input (U0203-1/9) off. This a mute condition which is not employed in this radio design. R0202 ensures that the base of Q0202 is high on power up. Otherwise there may be an audio pop due to R0236 pulling U0203-8 high before the software can switch on Q0200.

The SPK+ and SPK- outputs of the audio PA have a DC bias which varies proportionately with A+ CONT (U0200-7). A+ CONT of 11 V yields a DC offset of 5 V, and A+ CONT of 17 V yields a DC offset of 8.5 V. If either of these lines is shorted to ground, it is possible that the audio PA will be damaged. SPK+ and SPK- are routed to the accessory connector (J0403-1 and 3). Only the SPK- is routed to the control head. For the internal (control head) speaker to be enabled, a jumper must be placed on the accessory connector between pins 1 and 2; this connects SPK+ to the control head's INT SPK+.

Handset Audio
(Refer to schematic
page 10-29 for
reference)

Certain hand held accessories have a speaker within them which require a different voltage level than that provided by U0203. For those devices RX HI is available at J0405-8.

The received audio from the output of the ASFIC's digital volume attenuator is also routed to U0202 pin 6 where it is amplified 15 dB; this is set by the 10k/68k combination of R0238 and R0237. This signal is routed directly from the output of the op amp U202 pin 7 to J0405-8. The control head sends this signal directly out to the microphone jack. The maximum value of this output is 6.6 Vpp. If the handset is Off-Hook, the audio PA (U0203) is disabled. C0434 is for RF bypass and VR0418 is for static protection.

Filtered Audio
(Refer to schematic
page 10-25 for
reference)

This signal sources receive audio or Public Address audio to a large Siren PA accessory.

The ASFIC has an audio whose output at U0200-H5 has been filtered and de-emphasized, but has not gone through the digital volume attenuator. This signal is buffered with an op amp with a gain of 0 dB, within the ASFIC. The maximum level for this signal is 1.06 Vpp. From ASFIC U0200-H5 the signal is AC coupled to U0201-6 by capacitor C0214. R0209 and R0203 being equal value set up the op amp as a unity gain device, i.e. a buffer. The output at U0201-7 is then routed to J0403-11 FIL AUD OUT. Note that any volume adjustment of the signal on this path must be done by the accessory.

Discriminator
Audio (Unfiltered)
(Refer to schematic
page 10-23 for
reference)

Note that discriminator audio DISC from the ZIF, in addition to being routed to the ASFIC, is also routed to the Hear Clear (U0250) and both option connectors J0408-5 and J0401-5 (See "Hear Clear IC (Refer to schematic page 10-22 for reference)" on page 7-26 and "Secure Receive Audio" on page 7-24 for further information).

Auxiliary RX
Audio Paths

There are three auxiliary receive audio inputs that are buffered by U202 and routed to the auxiliary receive path in the ASFIC U0200-J6. The processing for this input is identical to that of normal received audio or it can bypass the filtering and de-emphasis. The auxiliary inputs come from the two option connectors J0408-9 and J0401-9 and from the accessory connector J0403-15. The "voltage mode" signal to U0400 is 9.3 V if the source for the auxiliary receive audio from J0403 is a current source. The "voltage mode" signal is 0 V if the auxiliary receive source is a voltage source. Typically current source mode will apply for SB9600 based devices. Note that the enable line for transmission gate U0400-12/10 is the same line VOLTAGE MODE as that which controls the Auxiliary TX path AUX TX IN2. The VOLTAGE MODE line is driven by Q0202 which is turned on and off by ASFIC GCB2. In order to change the state of VOLTAGE MODE the ASFIC (U0200) must be programmed by the SPI BUS to do so.

Secure Receive
Audio

Discriminator audio, which is now coded audio, enters the ASFIC at U0200-J7. Inside the ASFIC a path is set up to route the coded audio to a programmable 7 bit attenuator, where the signal level is adjusted, and then out of the ASFIC at UNIV IO (U0200-B2). This path bypasses the ASFIC RX filtering and Deemphasis. From U0200-B2 the coded audio goes to Option connectors J0401-10 / J0408-10.

On the secure board, the coded signal is converted back to analog format, and then fed back through (J0401-9 / J0408-9) to the Aux Rx buffer U0202. The clear audio signal is then routed to the ASFIC pin U0200-J6; from then on it

follows a path identical to conventional receive audio, where it is filtered (300-3 kHz) and deemphasis.

Receive Signalling Circuits

(Refer to Figure 7-5 for reference for the following sections)

The ASFIC (U0200) is used to filter and limit all received data. The data enters the ASFIC at U0200-J7. Inside U0200 the data is filtered according to data type (HS or LS), then it is limited to a 0-5 V digital level. The MDC and trunking high speed data appear at U0200-G4, where it connects to the μ P U0103-77, software decoder, and U0104-B8, hardware decoder (see SLIC description block for further details)

The low speed limited data output (PL, DPL, and trunking LS) appears at U0200-A4, where it connects to the SLIC. While receiving low speed data, the μ P may output a sampling waveform, depending on the sampling technique, to U0200-C3 of between 1 and 2 kHz.

The low speed data is read by the μ P at twice the frequency of the sampling waveform; a latch configuration in the ASFIC stores one bit every clock cycle. The external capacitors C0211, C0212, and C0203 set the low frequency pole for a zero crossings detector in the limiters for PL and HS data. The hysteresis of these limiters is programmed based on the type of received data. Note that during HS data the μ P may generate a sampling waveform seen at U0200-G1.

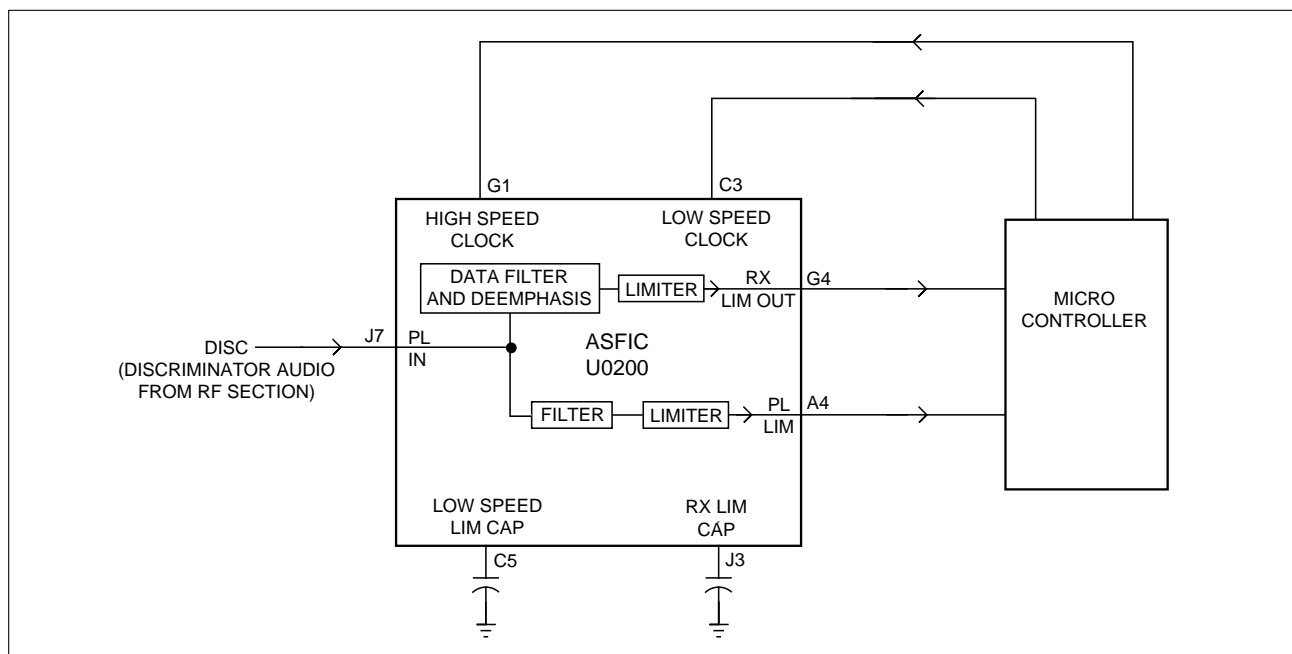

Figure 7-5 Receive Signalling Paths

Alert Tone Circuits

When the software determines that it needs to give the operator an audible feedback (for a good key press, or for a bad key press), or radio status (trunked system busy, phone call, circuit failures), it sends an alert tone to the speaker.

It does so by sending SPI BUS data to U0200 which sets up the audio path to the speaker for alert tones. The alert tone itself can be generated in one of two ways: internally by the ASFIC, or externally using the μ P and the ASFIC.

The allowable internal alert tones are 304, 608, 911, and 1823 Hz. In this case a code contained within the SPI BUS load to the ASFIC sets up the path and determines the tone frequency, and at what volume level to generate the tone. (It does not have to be related to the setting of the volume knob).

For external alert tones, the μ P can generate any tone within the 100-3000 Hz audio band. This is accomplished by the μ P generating a square wave which enters the ASFIC at U0200-C3.

Inside the ASFIC, this signal is routed to the alert tone generator; the output of the generator is summed into the audio chain just after the RX audio de-emphasis block. Inside U0200 the tone is amplified and filtered, then passed through the 8-bit digital volume attenuator, which is typically loaded with a special value for alert tone audio. Note that the Hear Clear expander is bypassed even if U0250 is present. The tone exits at U0200-J4, then is routed to the audio PA like receive audio.

Hear Clear IC
(Refer to schematic
page 10-22 for
reference)

The Hear Clear (HC) is typically used for 900 MHz radios. The HC has 3 main circuit blocks within the IC which are used by this radio; 1) Compressor, 2) Flutter Fighter, and 3) Expander circuits. There are 6 enable lines on the Hear Clear IC which determine its mode of operation. The IC ENAB line U0250-C4 is tied to SW B+, so whenever the IC is placed it is always active. The remaining 5 lines are controlled by the ASFIC General Control Bit lines, GCB0, GCB1, GCB3, GCB4, and GCB5. The table below summarizes their logic states.

Table 7-3 Hear Clear Enable Lines Configuration

			Logic State			
Name	Ref. Des	Set By	TX1	RX1	TX2	RX2
Ic Enable	U0250-C4	SW B+	1	1	X	1
Flutter Fighter Enable	U0200-B5	U0200-B5	X	1	X	0
LO Clamp Disable	U0250-A5	U0200-B3	1	1	1	X
Hi Clamp Enable	U0250-C2	U0200-C4	0	0	X	0
HCI Disable	U0250-B6	U0200-A3	1	1	X	1
Compander Enable	U0250-D1	U0200-A2	1	1	X	0

TX1: transmit mode with carrier squelch, PL or DPL.

RX1: receive voice with carrier squelch, PL or DPL.

TX2: transmit mode with all other data HST/MDC/MPT/DTMF etc.

RX2: refers to receive mode with all other data HST/MDC/MPT/DTMF

Logic State "X" means either 1 or a 0, i.e. "don't care".

Transmit Path for
Radios with Hear
Clear

For transmit, the signal comes from the appropriate microphone and enters the ASFIC at U0200-A7 or U0200-B6 as would standard TX audio. After entering the ASFIC, the signal is internally routed to U0200-A6 ASFIC MIC AMP OUT, where it leaves the ASFIC and enters the Hear Clear compressor at U0250-D3. The signal then exits the compressor at U0250-F3, where it is routed back to the ASFIC (U0200-C7). C0261 provides AC coupling. Inside the ASFIC the signal goes through an LPF and HPF which band limit the signal between 300 - 3 kHz. The signal is then pre-emphasized and exits the ASFIC at U0250-C8, passes through a coupling cap and enters the ASFIC at U0200-E8. Again inside the ASFIC the signal goes through a limiter, splatter filter, and a pair of attenuators which set the amplitude (deviation level) of the signal.

The Compressor is used in transmit mode. The purpose of this circuit is twofold; 1) improve S/N ratio for low level audio, and 2) maintain the same

dynamic range of a 12.5 kHz bandwidth channel as is obtained in a 25 kHz bandwidth channel.

The compressor raises low level signals and lowers high level signals. The compressor circuit produces a signal whose output voltage (U0250-F3) is based on the input voltage level (U0200-A6) of the signal. It is NOT a function of frequency (as is Preemphasis). The voltage transfer function is:

$$\text{COMPOUT} == \text{SQRT}[80 * \text{ASFICMICAUDOUT}]$$

Notice that 80 mV in yields 80 mV out. Some example levels are:

- 20 mV input == 40 mV output
- 80 mV input == 80 mV output
- 150 mV input == 110 mV output

Receive Path for
Radios with Hear
Clear

The audio signal enters the controller from the ZIF on DISC. The discriminated audio DISC enters the Hear Clear Flutter Fighter through C0200 and C0267. C0200 connects the signal to FF IN (U0250-E4). C0267 is the beginning of a noise sampling circuit consisting of components C0267, R0256, R0253, C0264, C0263, R0254, R0255, R0257, and C0265; and Hear Clear ports Clip Ref, Noise Filter In, and Noise Filter Out, Noise Hold.

After exiting the HC at FF OUT (U0250-F4), the signal enters the ASFIC at RX IN (U0200-H6). Within the ASFIC the signal passes through a low pass filter and a high pass filter limiting the audio band width to 300-3 kHz. It then goes through deemphasis and exits the ASFIC at U0200-H5 FILTERED AUDIO.

Upon exiting the ASFIC at FILTERED AUDIO, the signal passes through capacitor C0250, which provides AC coupling. The signal then enters the Hear Clear at EXP IN (U0250-C1) and exits the Hear Clear Expander at EXP OUT (U0250-A2). The normalized signal is then routed back to the ASFIC through C0260 for volume adjustment, entering at U0200-J5 and exiting the ASFIC at U0200-J4 as RX AUDIO. The audio is then routed to the Audio PA in the same manner as standard receive audio.

The Flutter Fighter is for receive only. It samples the amount of Noise in the receive audio between 10 kHz and 20 kHz, using the Noise filter in (U0250-B5), Noise filter out (U0250-C6), and Noise hold (U0250-D5) ports. In addition, it monitors the rate of change of RSSI (Receive Signal Strength In) (U0250-F5). The discriminated audio DISC enters the HC at FF IN (U0250-E4) and the circuit then reduces the amount of popping Noise associated with fading. The improved audio exits the IC at FF OUT (U0250-F4).

The Expander is used after deemphasis but before the ASFIC volume attenuator.

The purpose of the expander is to transpose compressed audio back to "normal" audio. As with the compressor circuit, the expander circuit adjusts the amplitude of a signal based upon its input amplitude, NOT its frequency.

The voltage transfer function is: $\text{EXPOUT} = 0.41 * (\text{EXPIN} / 0.28)^2$.

The importance here is to notice that an input signal of 191 mV will exit as 191 mV. A smaller signal will be made even smaller and a signal larger than 191 mV will exit EXP OUT even larger.

Some example levels are:

- 100 mV EXP IN == 52 mV EXP OUT
- 191 mV EXP IN == 191 mV EXP OUT
- 250 mV EXP IN == 327 mV EXP OUT

Again this operation is NOT A FUNCTION OF FREQUENCY between 300 Hz and 3 kHz.

Hear Clear
Routing of Data/
Signalling

All signalling for transmit enters the transmit stream after the Hear Clear Compressor and therefore does not pass through the compressor.

In receive, subaudible signalling PL/DPL goes through the Flutter Fighter along with audio, and is unaffected by the Flutter Fighter operation. After the Flutter Fighter, upon entering the ASFIC, the sub-audible signalling is separated from the audio and decoded. Subaudible signalling never passes through the expander.

In receive, for all other signalling HST/MDC/MPT etc. (not sub-audible), the Flutter Fighter is set to "Pass Through Mode". In this mode the Flutter Fighter passes signals from FF IN to FF OUT without any adjustment.

Control Heads



Model I

Introduction

The Control Head forms the interface between the radio and the user. It contains an LCD display, on/off and volume switch, keypad and control keys.

The microprocessor controlled Control Head interfaces to the radio control logic board J0650 via an 18-pin connector on the back of the unit. An external microphone/speaker is connected to the Control Head via the front mounted microphone connector P0651.

Power supplies

Power supply A+ (pin 17) is routed directly from the radio battery and is used for LCD and keypad backlight LEDs and indicator LEDs.

Power supply B+ (pin 18) is routed from the radio battery via the radio on/off switch and provides Vcc via regulator U0654.

Option SW B+ (pin 1) is the power supply output to the connected accessory. The current is monitored by the Control Head to operate the multiplexer. (Refer to Mode Select)

Audio configuration

The Control Head can be configured for Handset audio or Speaker+ which is a balanced output from the radio. Handset audio is configured by inserting R0676 in the line from pin 8 to the microphone connector. Speaker + audio is configured by inserting R0675 in the line from pin 1 to the microphone connector. Note that only one resistor R0676 or R0675 must be fitted.

Volume Control / on-off

Front panel switch/potentiometer R0698 controls the volume via A/D converter PD0 (pin 14) in micro-controller (μ C) U0653. The centre of the potentiometer is a push button switch used for microphone input and power on-off. When activated the microphone line (pin 9) is connected to ground.

Micro-controller

Micro-controller U0653 controls the operation of the Control Head. The μ C exchanges data with the radio via the SB9600 bus (TD0 and RD1) and monitors inputs from the microphone connector via the A/D port (PD0-PD7). The μ C is reset from the radio via the reset line (pin 3) and Q0652. The μ C is also reset by under voltage detector U0657 when Vcc drops below 4.6V.

Xtal Oscillator

The xtal oscillator is built using on chip oscillator gates of the microprocessor. The xtal is a standard 4 MHz ceramic resonator.

LCD

Backlight

The backlight consists of 10 LEDs. Light intensity is in 3 levels including off and is software controlled by bus commands via μ C U0653.

Driver	<p>The LCD driver U0651 contains the default character set. Its interface is a four line serial interface. The LCD driver is connected to the μC on pins PA0 - PA3. The driver has a built in oscillator with one external resistor, R0700, defining the clock frequency. The oscillator runs at approx. 25 kHz giving an LCD frame frequency of approx. 48 Hz.</p>
Power Supplies	<p>The LCD driver and bias voltages are powered either from 5.0 V or 5.7 V. The LCD bias voltage levels are created by the voltage divider R0701, R0702 and R0703. This gives four voltages: supply voltage (VDD), V1, V2 and V3=GND. The COM and SEG outputs from U651 jump between these 4 bias voltage levels, which create the on and off AC voltage for each LCD segment.</p> <p>Resistors R0715 and R0716 prevent U0651 from going into test mode during power up.</p> <p>The LCD supply voltage is controlled by the microcontroller U0653 PA6.</p>
Display	<p>Display (H0650) is a transmissive/reflective positive LCD display. The Control Head has one line of 8 characters with fixed symbols on top, four key-related symbols on the bottom and three colour indicators.</p>
Color Indicators	<p>The three color indicators are 4 LEDs D0679, D0680, D0681 and D0682. There are two yellow LEDs in order to increase the colour intensity.</p>
Keypad	
Backlight	<p>The keypad backlight is turned on and controlled along with the LCD backlight.</p>
Keypad	<p>The keypad is a static input with 10 kohms pull-up resistors. There is no scanning, but simply one input for each key. Debouncing control is handled by the software.</p>
Mode Select	<p>To reduce the number of pins on the microphone connector multiplexing is utilised to switch between the 3 different modes, Normal mode, SB9600 mode and Keyload mode.</p>
Multiplexer Operation	<p>The multiplexer comprises U0655 and U0656. Inputs to the multiplexer are from the microphone connector pins 3, 6 and 7. The multiplexer is switched either by a current sensing device (Q0662, Q0663), for Normal and SB9600 Bus modes, or by software for keyload mode. Pin 1 of the microphone connector carries the output current of the connected device.</p> <p>When the output current is below 30 μA, the multiplexer is switched to the Normal mode.</p> <p>When the connected device is an SB9600 device, the current is greater than 2 mA and the multiplexer is switched to SB9600 mode. Note that when an SB9600 device is self-powered, i.e. no current consumption from the microphone connector, a dummy load must be connected to pin 1 to ensure a minimum current of 2 mA and force the multiplexer into the SB9600 mode. A field programmer is an example of such a device.</p> <p>In the Secure keyload mode, an A/D input on the μC U0653 (PD6) monitors the Speaker-output dc voltage.</p>

If the output is short circuit to ground for more than 1 second, the μ C senses this and switches to keyload mode (via PC7 output).

Normal Mode	Typically a microphone with no microprocessor is connected to the microphone connector. Inputs in this mode include PTT, Monitor and Auxiliary. In Normal mode these inputs are routed to the μ C A/D port where the analogue voltage is measured and decoded for all possible combinations of PTT, Monitor and Auxiliary.
SB9600 Bus Mode	Typically a control microphone, intelligent handset or field programmer is connected to the microphone connector. Inputs include Bus+, Bus- and Busy. On selection of this mode Bus+ and Bus- are routed from the multiplexer via the bus comparator circuit (Q0655, Q0656 and U0658) to the μ C bus interface (RD1/TD0). Busy is routed to the radio via the Busy line (pin 14).
Secure Mode	This is the secure keyload mode. The inputs in this mode include WE (Write Enable), KID (Key Insert Data) and Key Fail. On selection of this mode these inputs are routed from the multiplexer to the radio via pin 10 (WE), pin 12 (KID) and pin 11 (Key Fail).

Models II and III

Introduction	<p>The Control Head forms the interface between the radio and the user. It contains an LCD display, on/off and volume switch, keypad and control keys. Control Head model II contains a rotary switch in place of a full keypad.</p> <p>The microprocessor controlled Control Head interfaces to the radio control logic board J0650 via an 18-pin connector on the back of the unit. An external microphone/speaker is connected to the Control Head via the front mounted microphone connector P0651.</p>
Power Supplies	<p>Power supply A+ (pin 17) is routed directly from the radio battery and is used for LCD and keypad backlight LEDs and indicator LEDs.</p> <p>Power supply B+ (pin 18) is routed from the radio battery via the radio on/off switch. It is routed to the microphone connector current sensor device (Q0664) and provides Vcc via regulator U0650.</p> <p>Option SW B+ (pin 1) is the power supply output to the connected accessory. The current is monitored by the Control Head to operate the multiplexer. (Refer to Mode Select)</p>
Audio Configuration	The Control Head can be configured for Handset audio or Speaker+ which is a balanced output from the radio. Handset audio is configured by inserting R0665 in the line from pin 8 to the microphone connector. Speaker + audio is configured by inserting R0664 in the line from pin 1 to the microphone connector. Note that only one resistor R0655 or R0644 must be fitted.
Volume Control/ Cn-Off	Front panel switch/potentiometer R0696 controls the volume via A/D converter PD0 (pin 14) in micro-controller (μ C) U0653. The centre of the potentiometer is a push button switch used for microphone input and power on-off. When activated the microphone line (pin 9) is connected to ground.

Micro-controller	Micro-controller U0653 and Data Expander U0654 control the operation of the Control Head. The μC exchanges data with the radio via the SB9600 bus (TD0 and RD1) and monitors inputs from the microphone connector via the A/D port (PD0-PD7). In addition keypad and LCD data is processed via ports A, B and C. Both the μC and the Expander are reset by under voltage detector U0660 when V_{cc} drops below 4.6 V. Both devices can also be reset from the radio via the reset line (pin 3) and Q0655.
Xtal Oscillator	The xtal oscillator is built using on chip oscillator gates of the microprocessor. The xtal is a standard 4 MHz ceramic resonator.
LCD	
Backlight	The backlight consists of 36 LEDs in model I and 48 LEDs in model J. Light intensity is in 4 levels including off and is software controlled by bus commands via Expander U0654 (Q6, Q7). A temperature condition in the Control Head overrides the software commands such that on rising to 78°C or above the lowest light level or off is selected.
Controller	LCD controller U0651 contains the default character set. On Control Head model J the controller is expanded by the use of an LCD driver U0652. The LCD controller is connected to the μC via data bus PA0-PA7, while the control and read/write (R/W) lines are connected via PB5 and PB7 respectively.
Power Supplies	The LCD bias voltage drives the display segments. The bias voltage is divided into 5 levels by R0707 to R0711 and routed to the LCD controller (and LCD driver in Control Head model J) under μC control via U0655. The μC measures the bias voltage with respect to V_{cc} (TP3) at A/D port PD3. Another function of the bias voltage is temperature which is measured across R0742 at A/D port PD7. The μC calculates the correction to the bias voltage and adjusts the duty cycle of the PLMA output to U0655 accordingly.
Display	Display (H0650) is a double layer super twist LCD display. Control Head model I has one line of 14 characters with fixed symbols on top, six key-related symbols on the bottom and RSSI symbol on the right-hand side. Control Head model J is similar but has two lines of 14 characters. The presence of a rotary switch tells the software that the display is a one-line display.
Temperature Sensor	μC U0653 measures voltage on PD7 which is controlled by dividers R0741 and R0742. R0742 is an NTC resistor which is placed in close proximity to the LCD display. The temperature sensor protects the backlight LEDs from failure and is also used to compensate the LCD bias voltage dependent on the LCD glass temperature. The protection temperature is 77°C \pm 6°C.
Keypad	
Backlight	The backlight consists of 7 LEDs in model I and 13 LEDs in model J. The backlight can be switched on/off by the radio software, controlled via μC U0653 TCMP1 and TCMP2. A high pulse on TCMP1 turns on the backlight and a low pulse on TCMP2 turns it off. If the temperature rises above 78°C in the Control Head the μC turns off the backlight utilising the Temperature Sensor input.
Keypad	The keypad is a passive input scanning matrix such that each key has 3 poles. When a key is pressed a row and column are connected to ground and sensed

by the μ C (PB0-PB4/PC0-PC4). Only Control Head model J contains a full keypad.

Rotary Switch

Rotary switch R0697 (Control Head model I only) is a double wiper continuous turn 16-step potentiometer. The two wipers are connected to two A/D inputs on the μ C U0653 (PD1, PD2). One input covers 8 steps from 0° to 180° and the other the 8 steps from 180° to 360°. The switch function is software programmable and may be used for example to select shortform call numbers.

Mode Select

To reduce the number of pins on the microphone connector multiplexing is utilised to switch between the 3 different modes, Normal mode, SB9600 mode and Keyload mode.

Multiplexer Operation

The multiplexer comprises U0657, U0658 and U0659. Inputs to the multiplexer are from the microphone connector pins 3, 6 and 7. The multiplexer is switched

either by a current sensing device (Q0664, Q0665), for Normal and SB9600 Bus modes, or by software for keyload mode. Pin 1 of the microphone connector carries the output current of the connected device.

When the output current is below 30 μ A, the multiplexer is switched to the Normal mode.

When the connected device is an SB9600 device, the current is greater than 2 mA and the multiplexer is switched to SB9600 mode. Note that when an SB9600 device is self-powered, i.e. no current consumption from the microphone connector, a dummy load must be connected to pin 1 to ensure a minimum current of 2 mA and force the multiplexer into the SB9600 mode. A field programmer is an example of such a device.

In the Secure keyload mode, an A/D input on the μ C U0653 (PD6) monitors the Speaker-output dc voltage. If the output is short circuit to ground for more than 1 second, the μ C senses this via R0689/R0690 network and switches the multiplexer to keyload mode via U0654 (Q1). This action overrides the current sensor device.

Normal Mode

Typically a microphone with no microprocessor is connected to the microphone connector. Inputs in this mode include PTT, Monitor and Auxiliary. In Normal mode these inputs are routed via the multiplexer to the μ C A/D port where the analogue voltage is measured and decoded for all four possible combinations of PTT/Monitor and the 4 Auxiliary levels.

SB9600 Bus Mode

Typically a control microphone, intelligent handset or field programmer is connected to the microphone connector. Inputs include Bus+, Bus- and Busy.

On selection of this mode Bus+ and Bus- are routed from the multiplexer via the bus comparator circuit (Q0660, Q0661 and U0656) to the μ C bus interface (RD1/TD0). Busy is routed to the radio via the Busy line (pin 14).

Secure Mode

This is the secure keyload mode. The inputs in this mode include DVP WE (DVP Write Enable), KID (Key Insert Data) and Key/Fail. On selection of this mode these inputs are routed from the multiplexer to the radio via pin 10 (DVP WE), pin 12 (KID) and pin 11 (Key/Fail).

NOTES

Troubleshooting

This chapter contains the troubleshooting flowchart diagrams for the Overall radio and for the Controller section of the radio as well as the Control Heads.

Troubleshooting flowcharts for the RF section will be found in Volume 2a, 2b, 2c, 2d or 2e of this manual depending on the frequency range.

Refer to the SECURENET option service manual (part number 68P81083C25) for troubleshooting information and troubleshooting flowchart diagrams for the SECURENET Option for the radio.

The following chart will give you an overview of the complete set of troubleshooting charts available for servicing a radio.

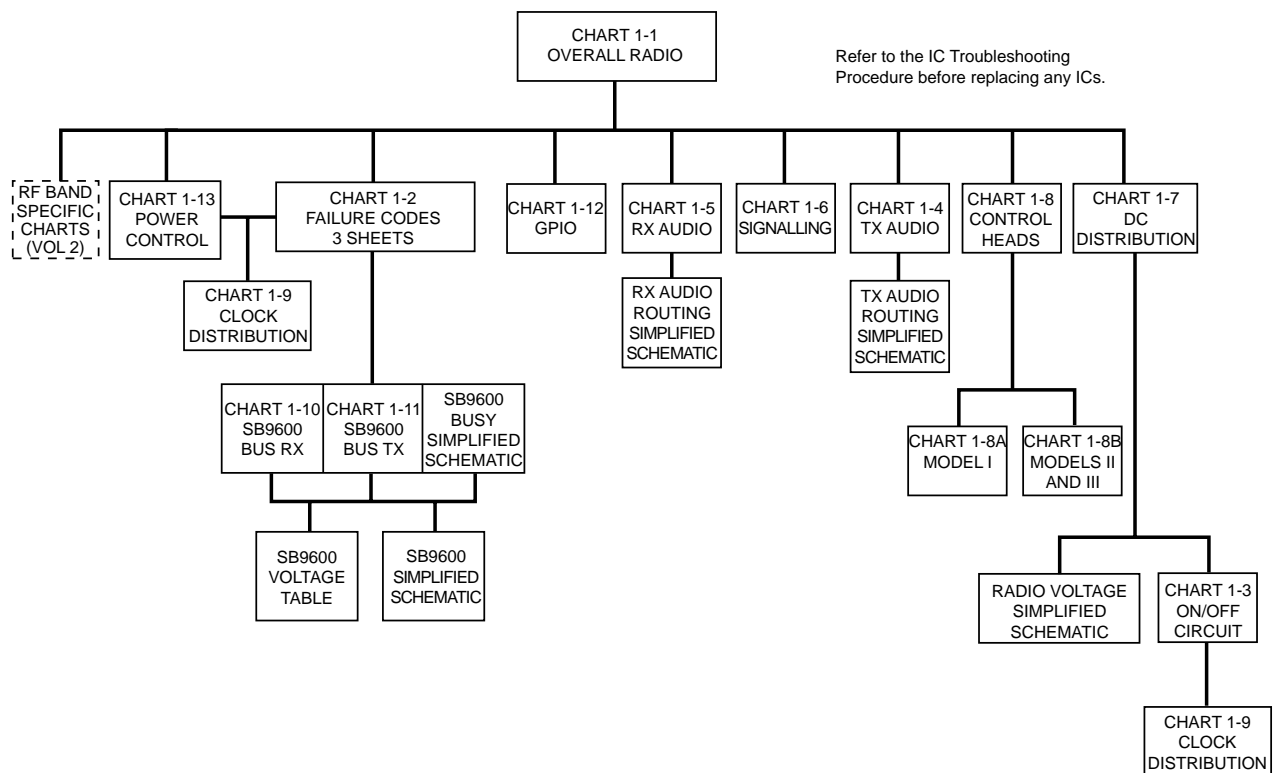
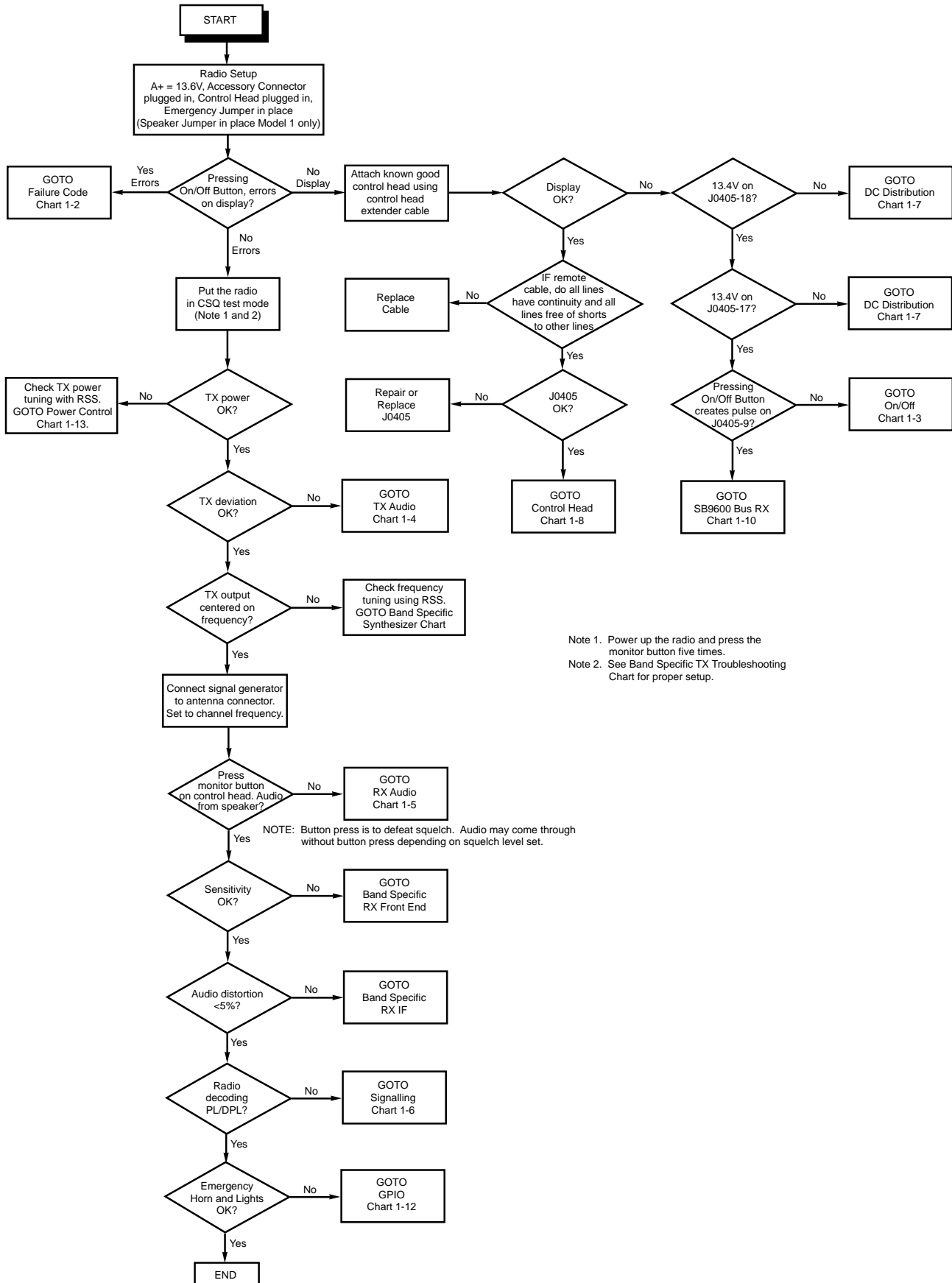

Figure 9-1 Troubleshooting Charts Overview

Troubleshooting Chart 1-1, Overall Radio



Note 1. Power up the radio and press the monitor button five times.
Note 2. See Band Specific TX Troubleshooting Chart for proper setup.

Troubleshooting Chart 1-2 (1 of 3), Failure Codes

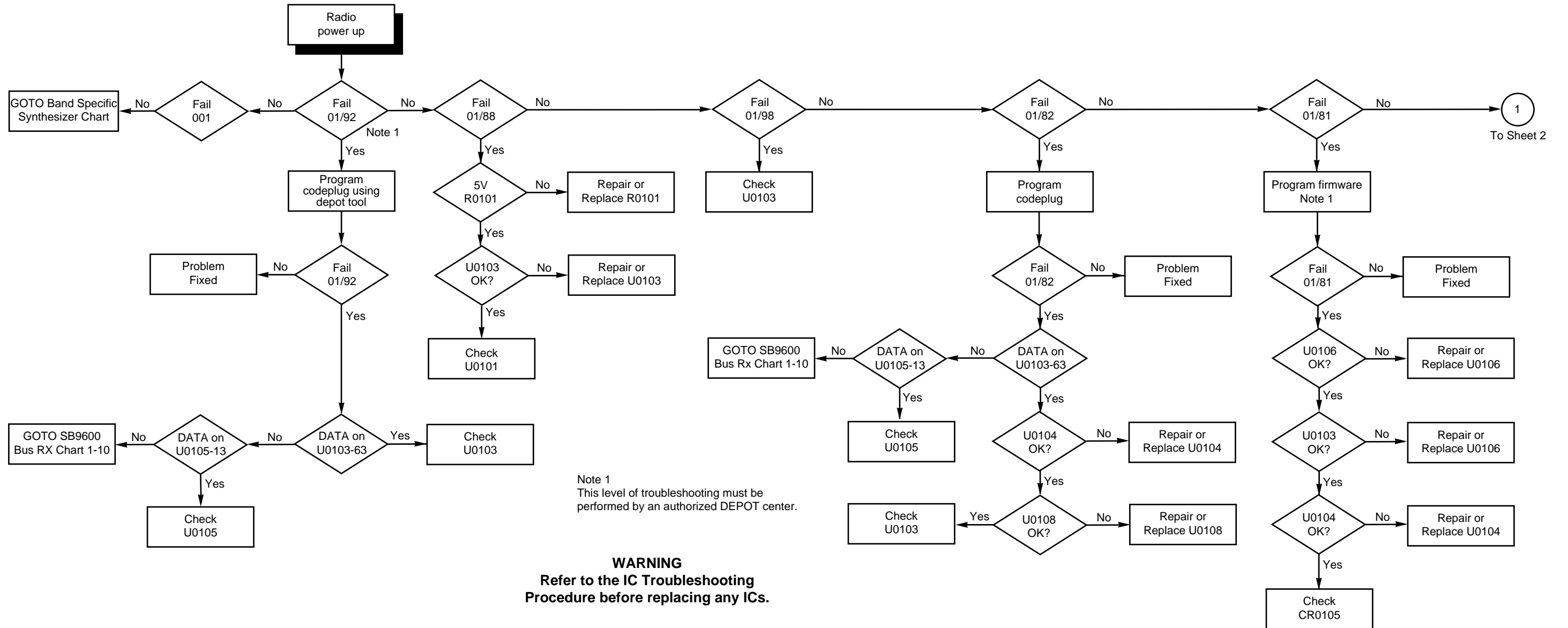

Troubleshooting Chart 1-2 (2 of 3), Failure Codes

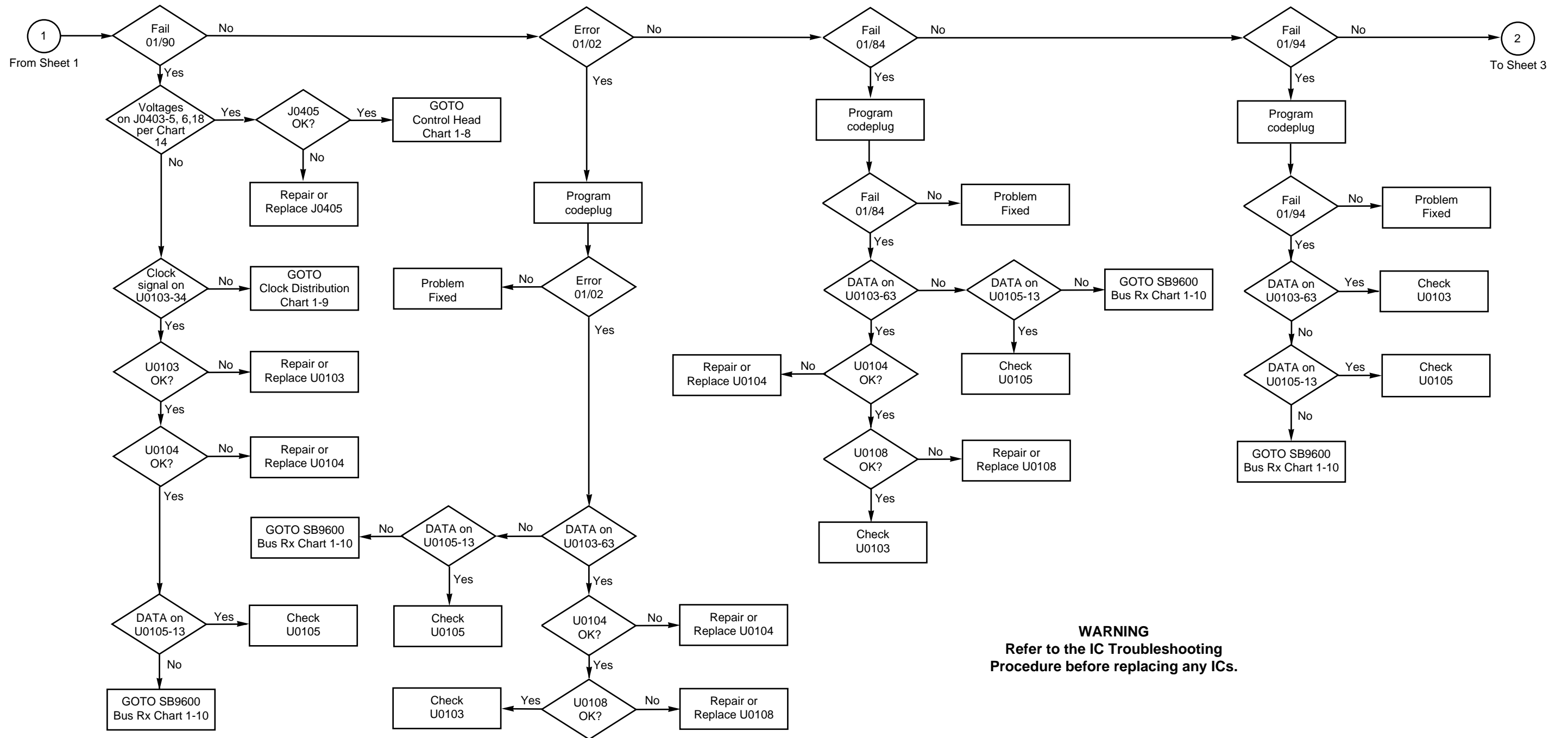

WARNING
Refer to the IC Troubleshooting Procedure before replacing any ICs.

Troubleshooting Chart 1-2 (3 of 3), Failure Codes

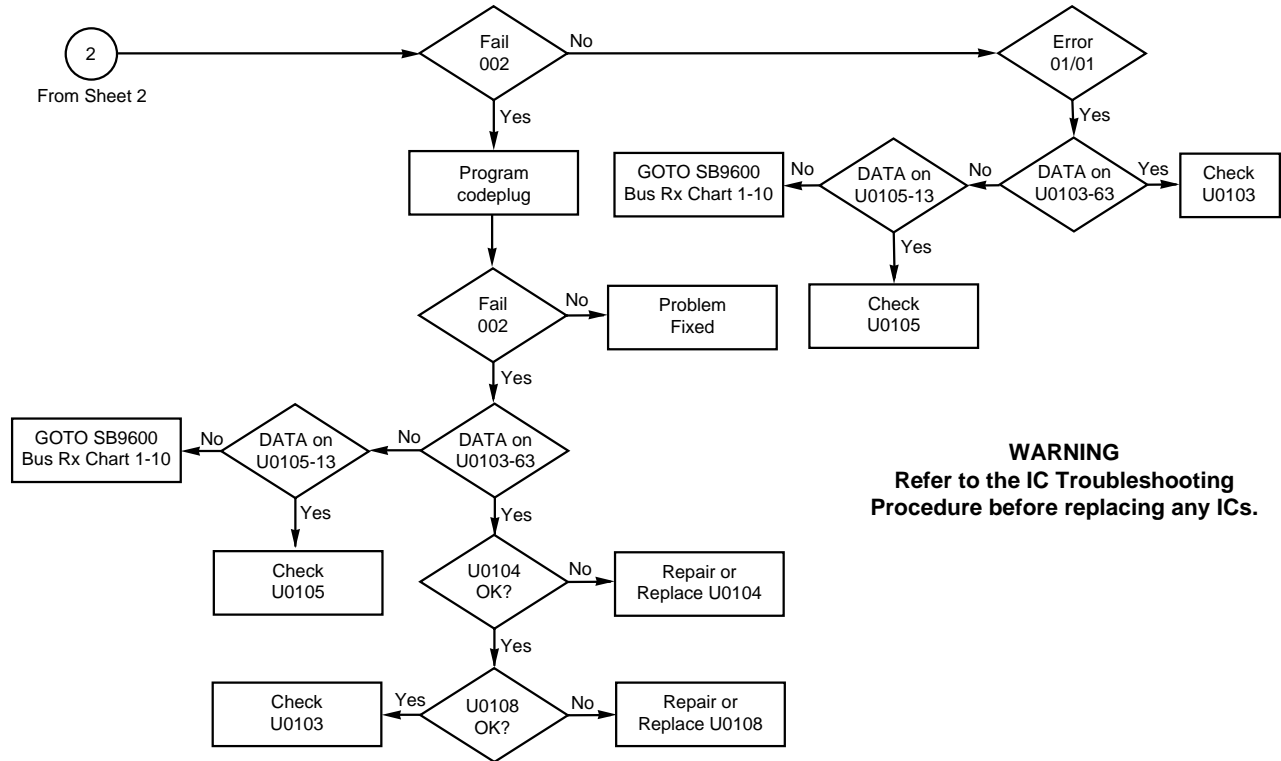

WARNING
 Refer to the IC Troubleshooting Procedure before replacing any ICs.

Troubleshooting Chart 1-3, On/Off Circuit

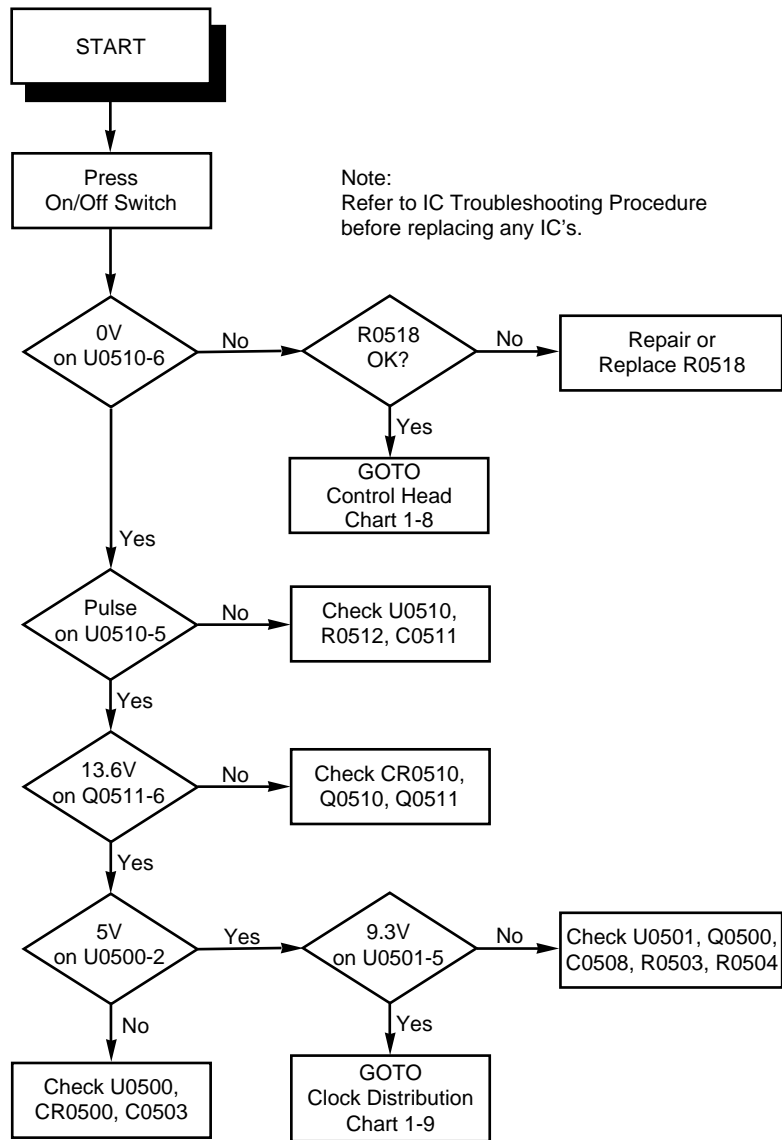

Troubleshooting Chart 1-4, TX Audio

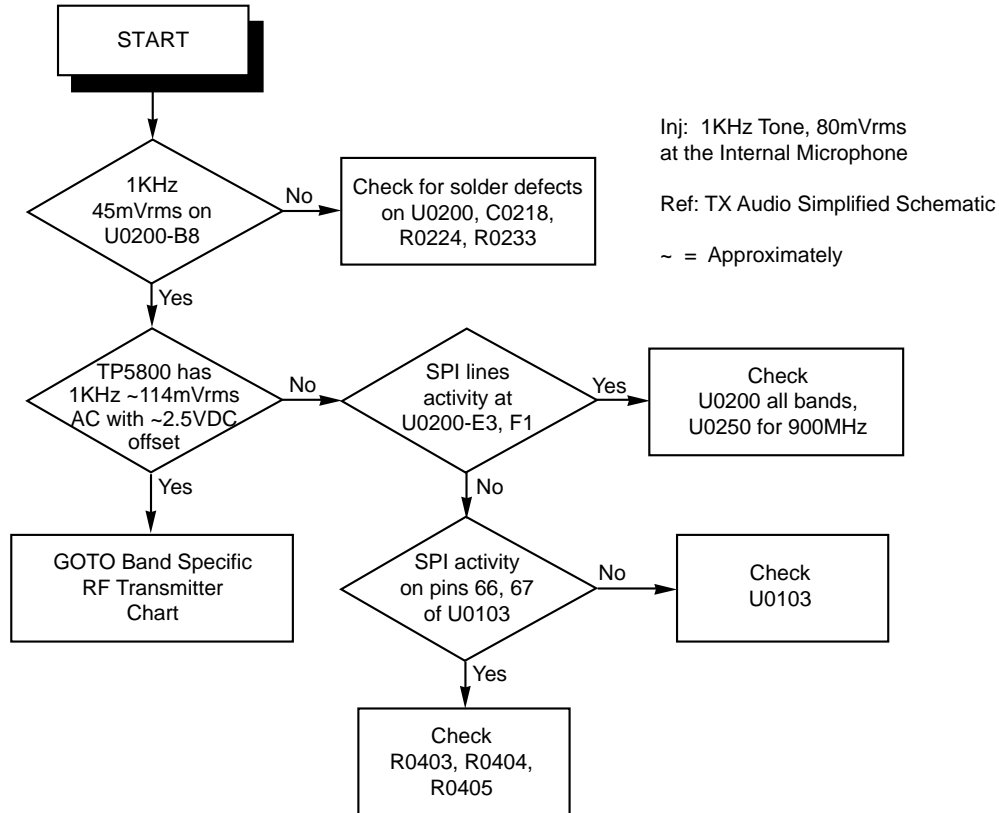

TX Audio Routing, Simplified Schematic for Chart 1-4

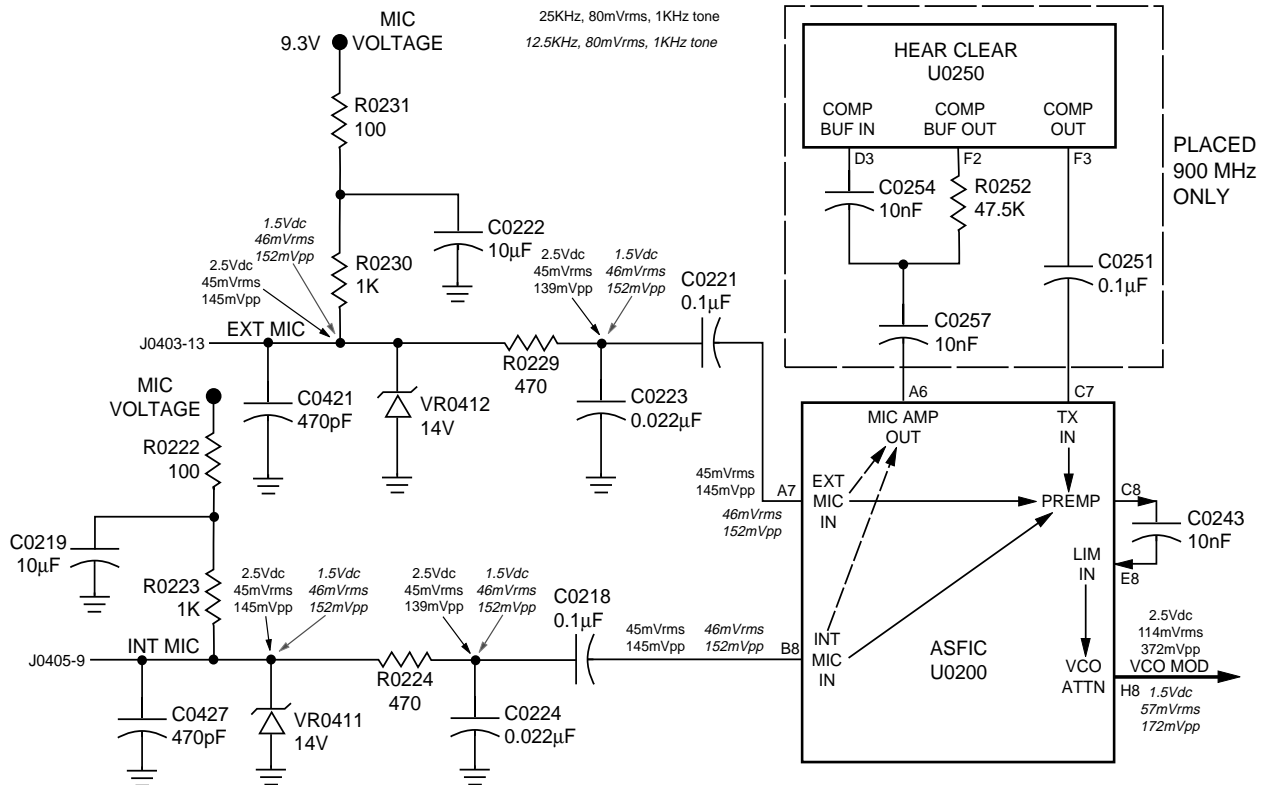

Troubleshooting Chart 1-5, RX Audio

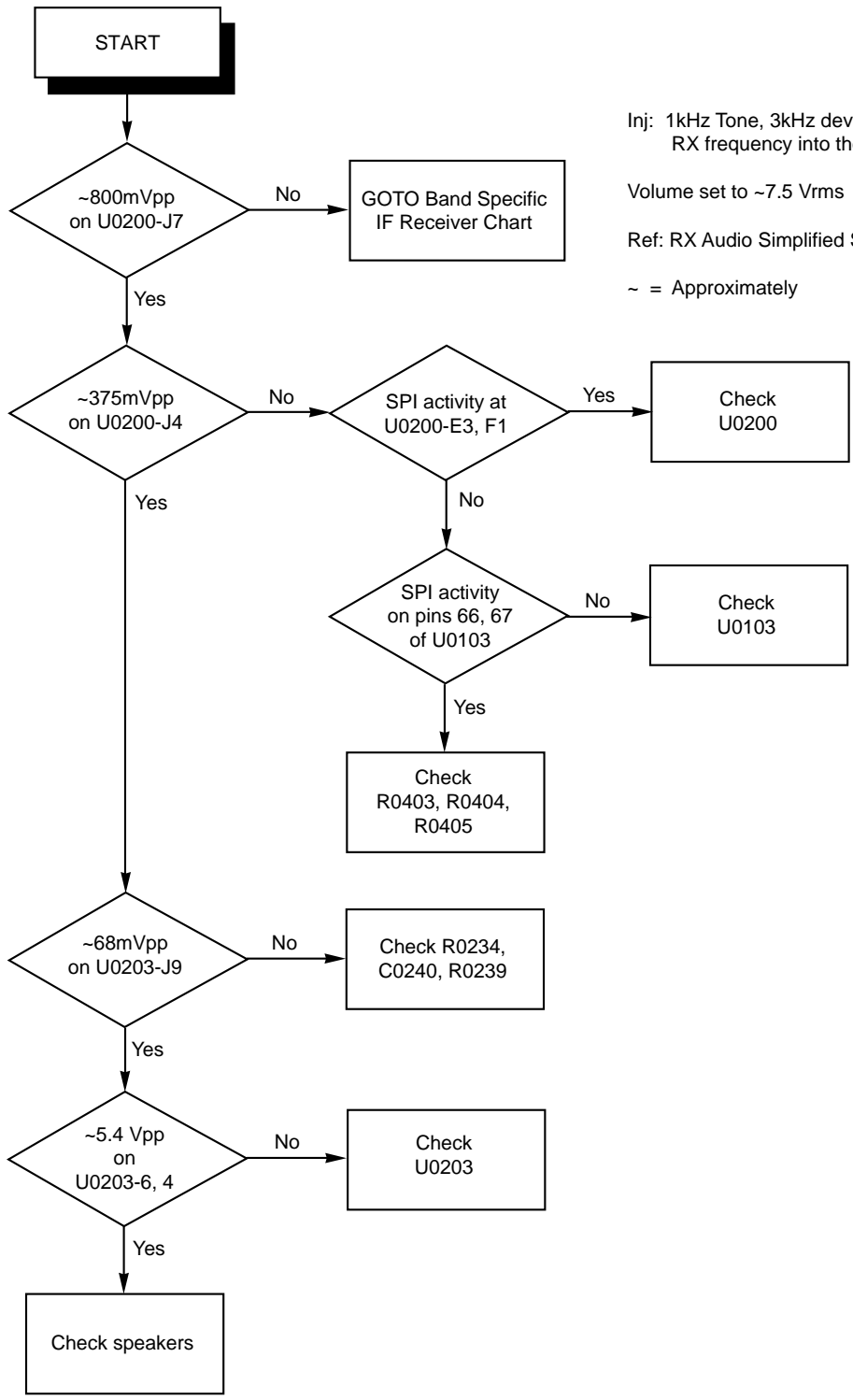

Inj: 1kHz Tone, 3kHz deviation at the appropriate RX frequency into the antenna connector.
 Volume set to ~7.5 Vrms
 Ref: RX Audio Simplified Schematic
 ~ = Approximately

Troubleshooting Chart 1-6, Signalling

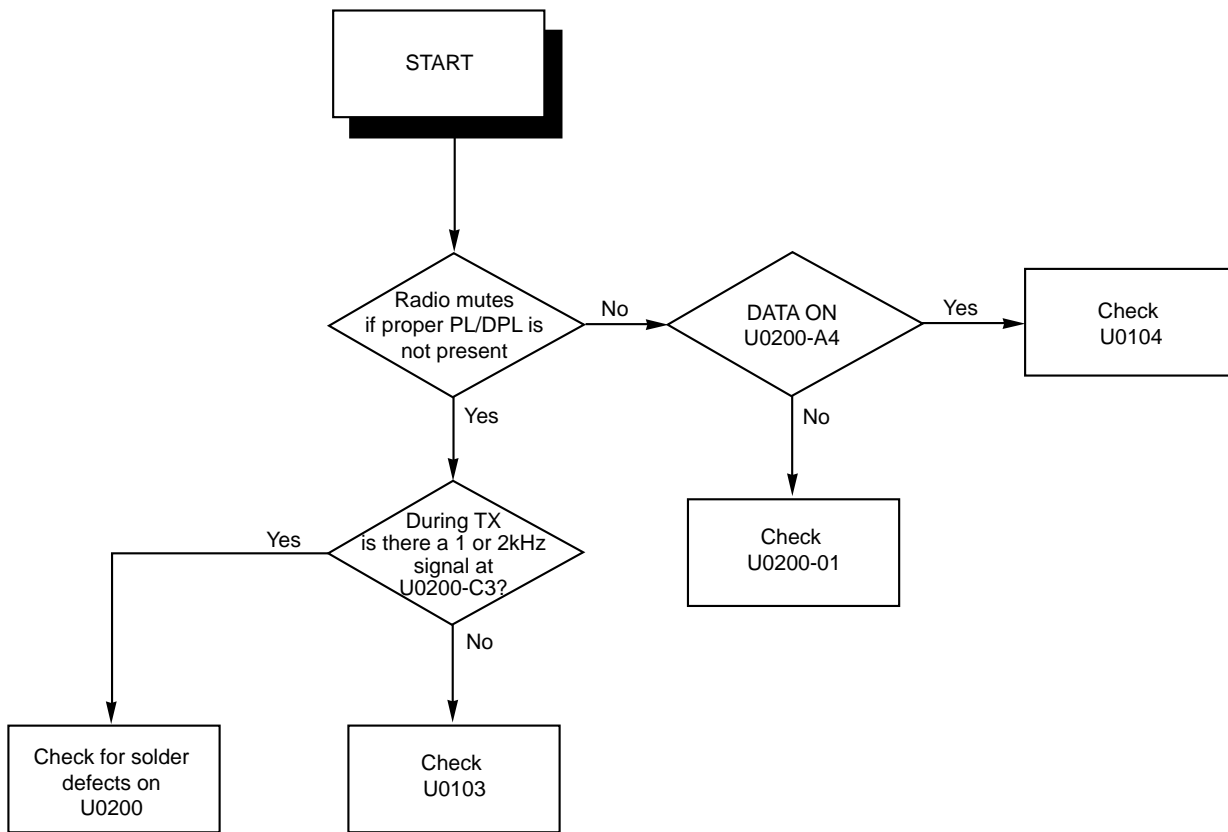

Troubleshooting Chart 1-7, DC Distribution

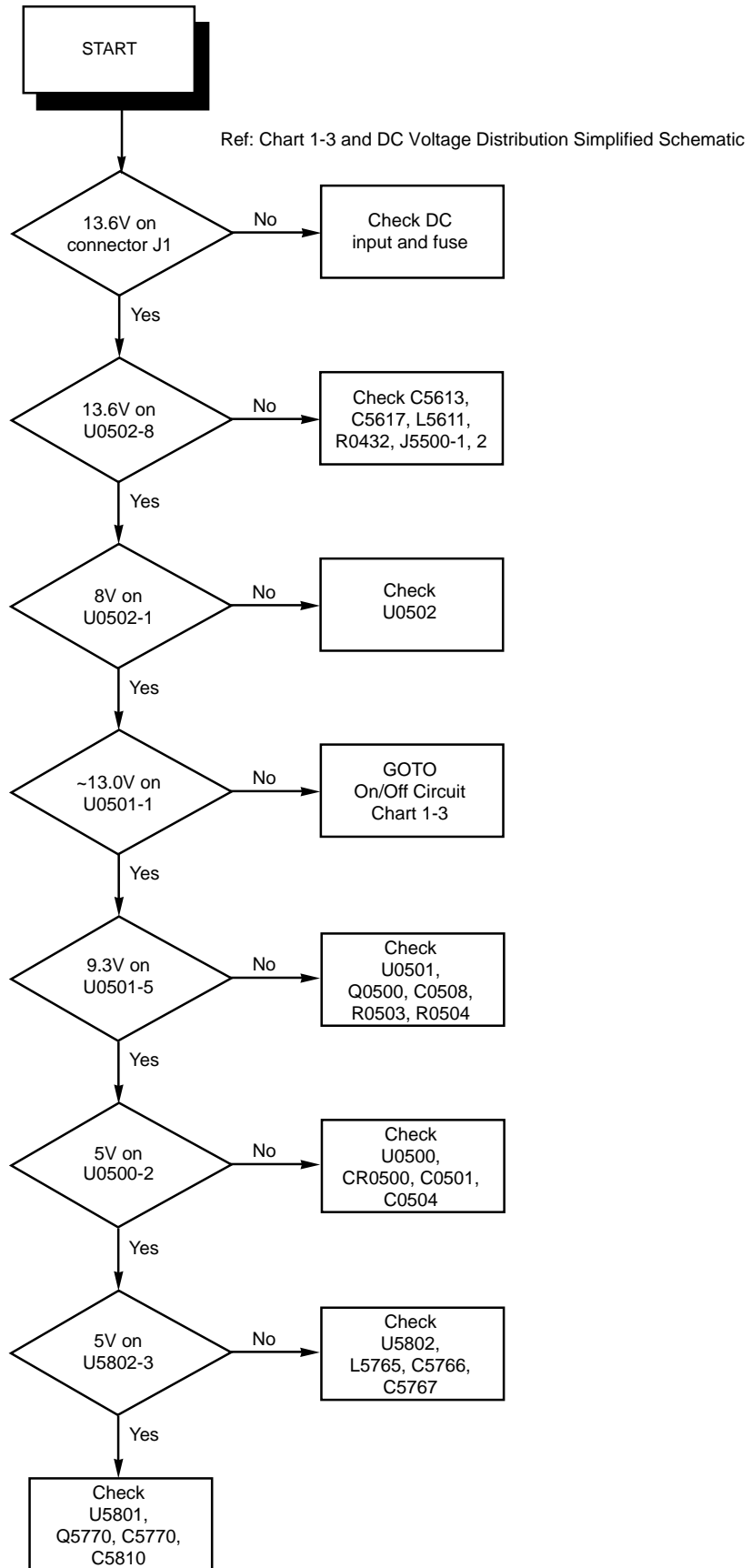

Radio Voltage, Simplified Schematic For Chart 1-7

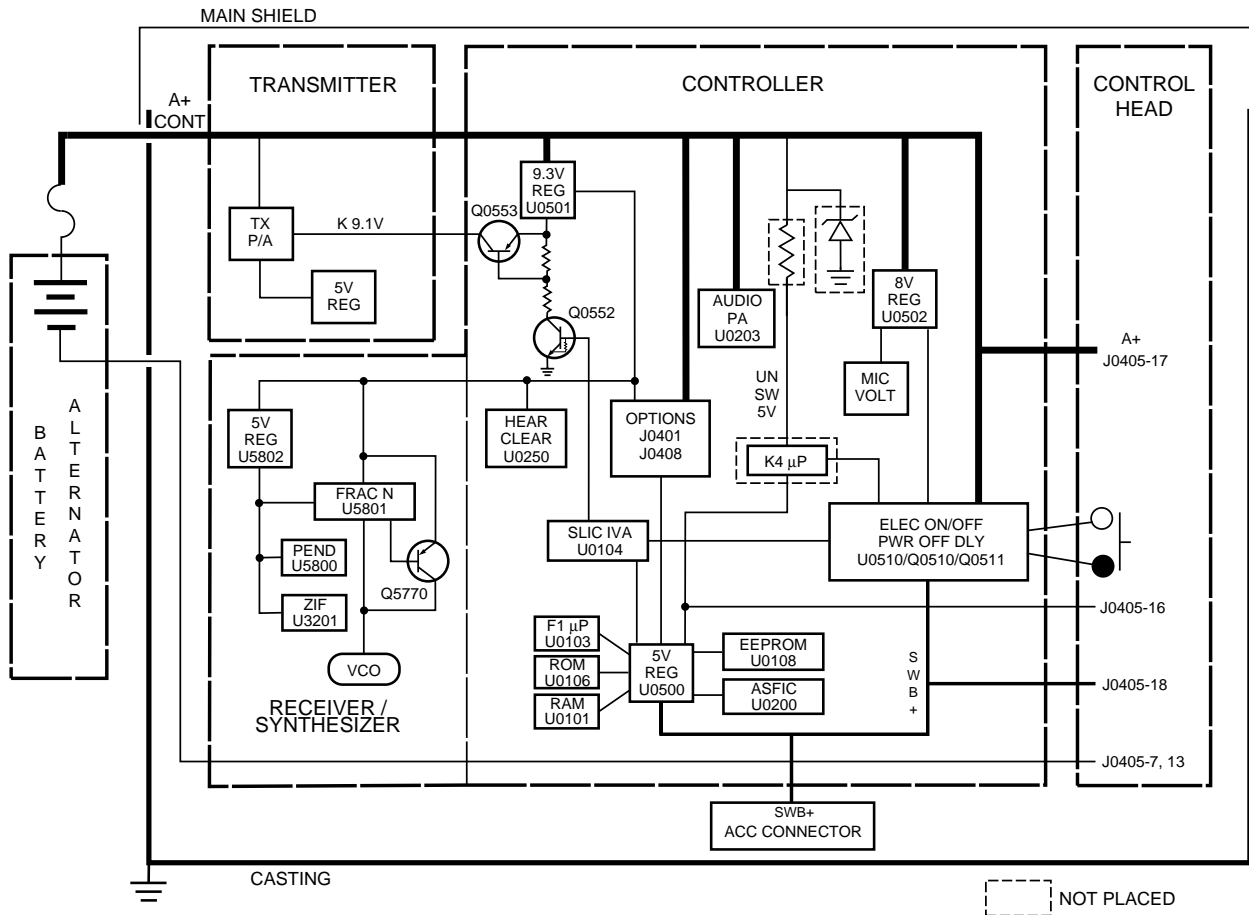

Troubleshooting Chart 1-8A, Control Head Model I

Numbers in brackets refer to accompanying troubleshooting procedure overleaf.

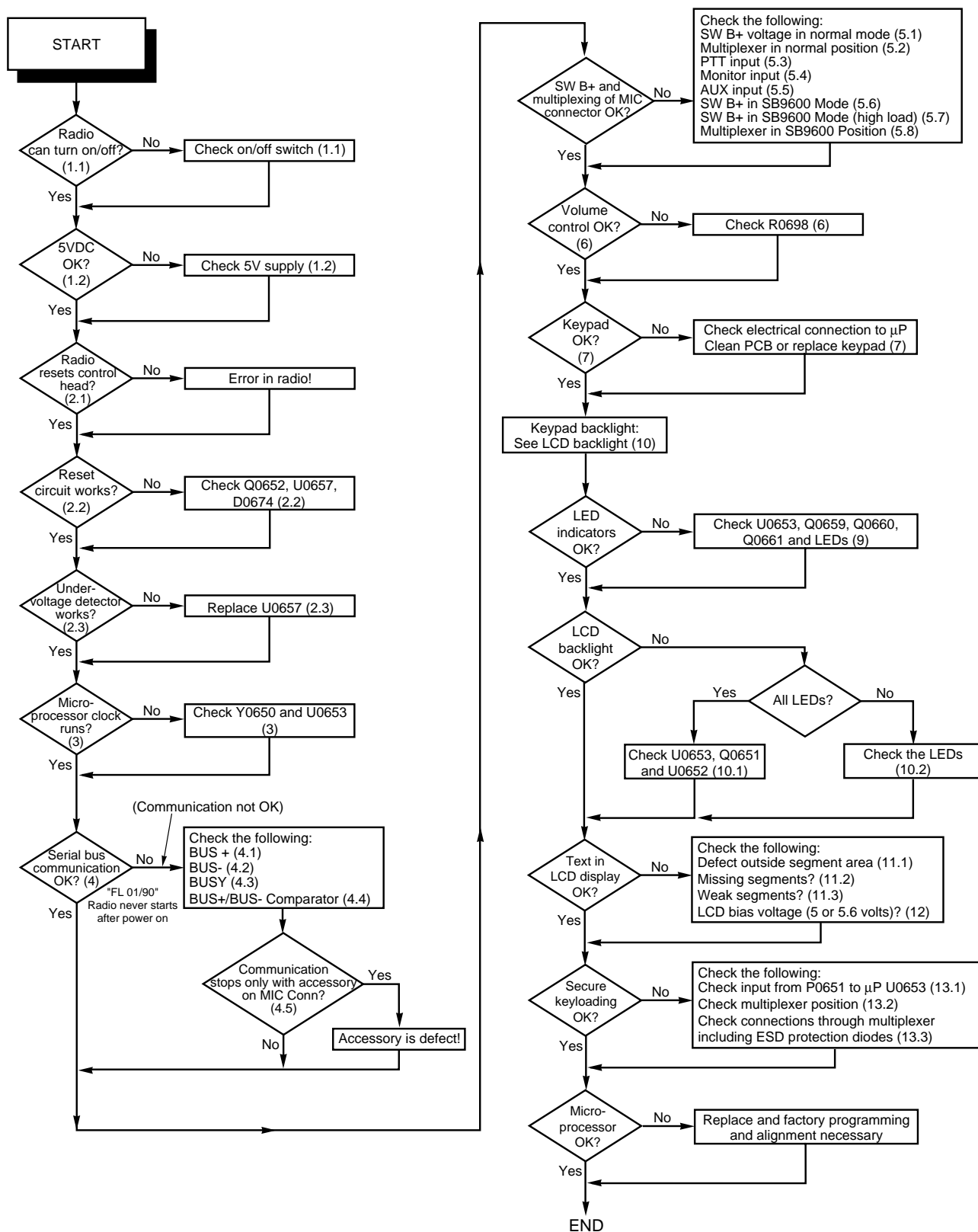

Control Head I Troubleshooting Procedure

1 Power Supply

Check that the radio is connected to a power supply.

1.1 ON/OFF switch

- Check that radio turns on. I.e. SW B+ is 12V DC. If not, press the ON/OFF switch to turn the radio off again.
- If the radio does not turn ON, verify that there is DC voltage on the MIC-HI/ON_OFF line and that this voltage goes to ground when pressing the ON/OFF switch.
- If DC voltage is present, but does not go low, check J0650 and R0698.

1.2 5V DC supply

12VDC is now assumed to be present both on A+ and SW B+.

- Check that there is 5 VDC on U0654 pin 3. If not check R0673 and U0654.

2 Reset

- Check that the control head reset is functional.

2.1 Radio resets control head

- Monitor uP reset on U0653 pin 18 with an oscilloscope. Turn radio off and on.
- Check that the uP reset goes from low to high (5 VDC) after power up and stays high.

2.2 Check reset circuit

- If U0653 is not reset check Q0652 and U0657.
- Check that D0674 is not shorted.

2.3 Check the undervoltage detector IC U0657

- Disconnect the control head from the radio and connect J0650 pins 7 and 13 to ground and pins 17 and 18 to a variable DC supply.
- Measure the DC voltage at U0654 pin 3.
- Monitor U0657 pin 1.
- Increase slowly the DC supply starting from 4 V.
- Check that U0657 pin 1 changes from 0V to 5 VDC when TP3 is approx. 4.3 V. If not replace U0657.
- Connect J0650 pin 3 to U0654 pin 3 (VCC). Check that U0657 pin 1 goes low.
- If not replace Q0652.

2.4 Continuous reset

- If the control head is continuously reset by the radio it may be due to a bus communication problem or the microprocessor not working.

3 Microprocessor Clock

- Check that the microprocessor oscillator is working (4 MHz square wave on TP2). If not, check Y0650 and U0653.
- Clean PCB area round Y0650.

4 Serial Bus Communication

A general serial bus communication problem in the radio is typically indicated by the radio remaining inactive on power up, and the display showing "FL 01/90".

Make sure that no accessory is connected to P0651 (MIC Connector) and check the following lines with an Oscilloscope while turning the radio on and off.

4.1 SB9600 BUS+, J650 pin 15

- This signal is normally 5 VDC with short pulses to 0V when data are sent on the bus. If it is constantly 0 V or 5 VDC check D0677 (most common error), Q0655 and Q0656.

- Check that U0653 pin 52 is 5 VDC with pulses to ground while transmitting data. Then check U0655 (disconnect pin 1). If problem disappears and OPTION SW B+ circuit is OK (see 5.), replace U0655. If the OPTION SW B+ circuit is defect, D0684 should also be checked.

4.2 SB9600 BUS-, J650 pin 4

- This signal is normally 0 V with short pulses to 5 VDC when data are sent on the bus. If it is constantly 5 VDC or 0 V, check D0678 (most common error), Q0657 and Q0656.
- Check that U0653 pin 52 is 5 VDC with pulses to ground while transmitting data. Then check U0655 (disconnect pin 12). If problem disappears and OPTION SW B+ circuit is OK (see 5.), replace U0655. If the OPTION SW B+ circuit is defect, D0683 should also be checked.

4.3 SB9600 BUSY, J650 pin 14

- This signal is 0 V with pulses to 5 VDC when data are sent on the bus. If it is constantly 5 VDC or 0 V, check D0675 (most common error) and Q0653. Check that U0653 pin 43 is 5 VDC with pulses to ground while sending data.
- Then check U0656 (disconnect pins 1 and 12). If problem disappears and OPTION SW B+ circuit is OK (see 5.), replace U0656. If the OPTION SW B+ circuit is defect, D0685 should also be checked.

4.4 SB9600 data in comparator

- If the above voltages are correct, check U0652, Q0658 and Q0656. Finally check U0653.

4.5 Communications stops only with accessory on MIC Conn

- If bus communication stops working only when an accessory is connected to the MIC Connector (P0651), check the OPTION SW B+ circuit (See 5.). The accessory is either defect or incompatible.

5 OPTION SW B+/Multiplexing of MIC Connector

Normal mode = No or simple microphone connected.

SB9600 mode = Smart accessory with serial bus connected.

5.1 SW B+ in Normal mode

- Make sure no accessory is connected to the MIC Connector (P0651).
- With power connected to the control head on J0650 pins 17 and 18, check that the DC voltage on P0651 pin 1 is approx. 12 VDC. If not check Q0662.

5.2 Multiplexer in normal position

- Check that the voltage on U0655/U0656 pin 10 is 5 VDC. If this fails, check Q0662 and Q0663.

5.3 PTT input

- Check that the voltage on U0653 pin 46 changes from 5 VDC to 0 V when P0651 pin 6 is connected to ground (equivalent to pressing PTT on a standard microphone).
- If this fails, check U0655.

5.4 Monitor input

- Check that the voltage on U0653 pin 45 changes from 5 VDC to 0 V when P0651 pin 3 is connected to ground.
- If this fails check U0656.

5.5 AUX input

- Check that the voltage on U0653 pin 5 changes from 5 VDC to approx. 0 VDC when P0651 pin 7 is connected to ground.
- If this fails check U0655.

5.6 SW B+ in SB9600 mode

- Connect a 5.6 kohm resistor from P0651 pin 1 to ground (a keypad microphone can be used instead).
- Check that the DC voltage on P0651 pin 1 is still approx. 12 VDC.
- If not check Q0662.

5.7 SW B+ in SB9600 mode (high load)

- Connect a 68 ohm resistor from P0651 pin 1 to ground.
- Check that the DC voltage on P0651 pin 1 is still approx. 12 VDC.
- If not check Q0662.

5.8 Multiplexer in SB9600 position

- Connect a 5.6 kohm resistor from P0651 pin 1 to ground (a keypad microphone can be used instead).
- Check that the voltage on U0655/U0656 pin 10 is 0 VDC.
- If this fails check Q0662 and Q0663.

6 Volume Control

- Turn R0698 fully counter clockwise and then fully clockwise and verify the voltage on U0653 pin 14 goes from 0 V to 5 VDC.
- If not, check R0698.

7 Keypad

- Check that when pressing a key, the correct input to U0653 pins 33-39 goes low. The actual pins can be found on the schematic diagram.
- Clean the carbon pads with alcohol.
- Check carbon on rubber keypad. If defect, replace keypad.

8 Key backlight

See LCD backlight.

9 LED indicators

- Check that the outputs from U0653 pin 49 (yellow), pin 48 (red) and pin 47 (green) changes to 5 VDC when LED must go ON.
- Check Q0659 (yellow), Q0660 (red) and Q0661 (green).
- Check the LEDs.

10 LCD backlight

10.1 All LEDs

If backlight cannot be turned on or off.

- Check that U0653 pins 26 and 27 are 5 VDC. If not check U0653.
- Check that the voltage of base on Q0651 is approx 1.5 VDC.
- Check Q0651 and U0652.

10.2 One/some LEDs

- One LED is off. Check the LED.
- One row of LEDs is off. Find the LED that makes the short circuit.

11 LCD

11.1 Defect outside segments of display

- If the LCD has either light or dark areas outside the segment, the LCD glass is defect and must be replaced.

11.2 Missing segments

- Missing segments. Most likely a bad connection between PCB and LCD. Disassemble and clean PCB and zebra connector with alcohol. LCD glass surfaces can be cleaned with distilled water with 3% ammonium chloride; never use alcohol on the LCD glass.
- If necessary replace the zebra connector or LCD.

11.3 Weak segments

- Segment brightness depends on the text displayed. Most likely a short between the lines from display controller/driver to LCD. Disassemble and clean PCB and zebra connector with alcohol. If necessary replace the zebra connector.
- Check U0651.

NOTE: When monitoring the signal on the LCD controller/driver outputs, a complex signal pattern is seen that jumps in 4 discrete voltage from 0V to + 5V. Waveform depends on the contents of the display. Outputs are never steady. A signal can always be seen on a scope unless there is a short, or the LCD driver is defect.

12 LCD bias voltage

If segments that should be on are weak or segments that should be off are partly lit, the problem may be the bias voltage.

- Measure the LCD bias voltage (DC) between TP1 (+) and GND.
- The voltage should be approx. 5 VDC or 5.6 VDC depending on the viewing angle setting.
- Check Q0650.

13 Secure keyloading

13.1 Secure keyloader sensing

- Connect P0651 pin 2 to ground. Check that DC voltage on U0653 pin 4 goes to 0 V. If not, check P0651, R0679, R0678 and C0668.

13.2 Multiplexer in keyload position

- Check that U0653 pin 42 goes to 5 VDC. If not check U0653.

13.3 Connections through multiplexer

- Check that P0651 pins 6, 3 and 7 are connected to J0650 pins 10, 12 and 11 respectively. If not check U0655 and U0656.
- Also check D0683, D0684, D0685 and D0676.

14 Microprocessor U0653

Replacement of U0653 requires special factory programming and alignment (currently not available in the radio service software).

Troubleshooting Chart 1-8B, Control Head Models II & III

Numbers in brackets refer to accompanying troubleshooting procedure overleaf

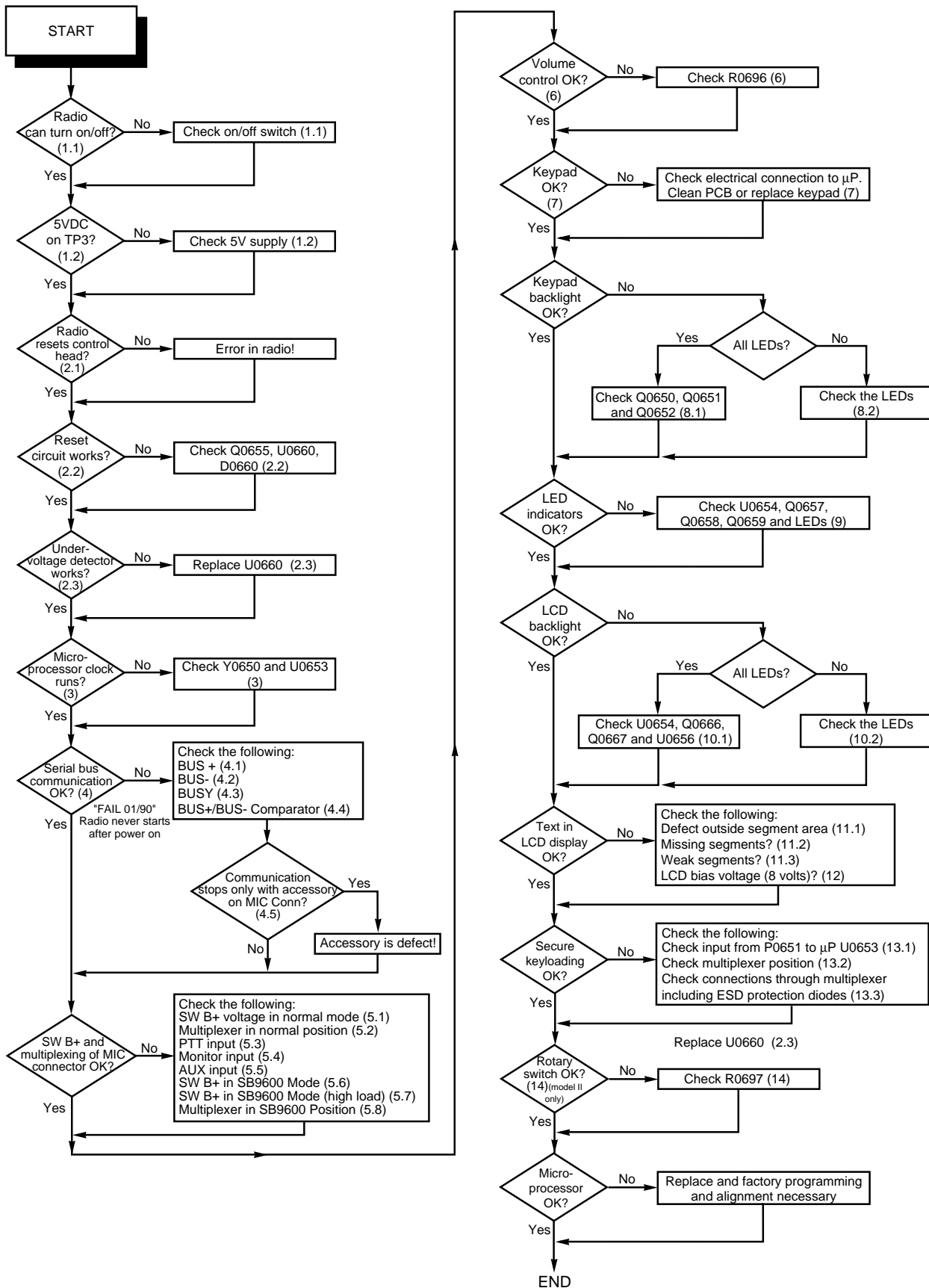

Control Heads II and III Troubleshooting Procedure

1 Power Supply

Check that the radio is connected to a power supply.

1.1 ON/OFF switch

- Check that radio turns on. I.e. SW B+ is 12V DC. If not, press the ON/OFF switch to turn off radio.
- If the radio does not turn on, verify that there is DC voltage on the MIC-HI/ON_OFF line and that this voltage goes to ground when pressing the ON/OFF switch.
- If the DC voltage is present but does not go low check J0650 and R0696.

1.2 5V DC supply

- 12VDC is now assumed to be present both on A+ and SW B+.
- Check that there is 5 VDC on TP3. If not check R0651 and U0650.

2 Reset

- Check that the control head reset is functional.

2.1 Radio resets control head

- Monitor uP reset on U0653 pin 18 with an oscilloscope. Turn radio off and on.
- Check that the uP reset goes from low to high (5 VDC) after power up and stays high.

2.2 Check reset circuit

- If U0653 is not reset check Q0655 and U0660.
- Check that D0660 is not shorted.

2.3 Check the undervoltage detector IC U0660

- Disconnect the control head from the radio and connect J0650 pins 7 and 13 to ground and pins 17 and 18 to a variable DC supply.
- Measure the DC voltage at TP3.
- Monitor U0660 pin 1.
- Increase slowly the DC supply starting from 4 V.
- Check that U0660 pin 1 changes from 0V to 5 VDC when TP3 is approx. 4.3 V. If not replace U0660.
- Connect J0650 pin 3 to TP3. Check that U0660 pin 1 goes low. If not replace Q0665.

2.4 Continuous reset

- If the control head is continuously reset by the radio it may be due to a bus communication problem or the microprocessor not working.

3 Microprocessor Clock

- Check that the microprocessor oscillator is working (4 MHz square wave on TP2). If not check Y0650 and U0653.
- Clean PCB area round Y0650.

4 Serial Bus Communication

A general serial bus communication problem in the radio, when the control head is connected, is typically indicated by an inactive radio on power up or the display showing "FAIL 01/90".

Make sure no accessory is connected to P0651 (MIC Connector). Check the following lines with an Oscilloscope while turning the radio on and off.

4.1 SB9600 BUS+, J650 pin 15

- This signal is normally 5 VDC with short pulses to 0V when data are sent on the bus. If it is constantly 0 V or 5 VDC check D0665 (most common error), Q0663 and Q0662. Check that U0653 pin 52 is 5 VDC with pulses to ground while sending data.
- Then check U0659 (disconnect pins 1 and 12). If problem disappears and OPTION SW B+ circuit is OK (see 5.), replace U0659.
- If the OPTION SW B+ circuit is defect, D0669 should also be checked.

4.2 SB9600 BUS-, J650 pin 4

- This signal is normally 0 V with short pulses to 5 VDC when data are sent on the bus. If it is constantly 5 VDC or 0 V, check D0664 (most common error), Q0661 and Q0662. Check that U0653 pin 52 is 5 VDC with pulses to ground while sending data.
- Then check U0657 (disconnect pins 1 and 12). If problem disappears and OPTION BW B+ circuit is OK (see 5.), replace U0657.
- If the OPTION SW B+ circuit is defect, D0667 should also be checked.

4.3 SB9600 BUSY, J650 pin 14

- This signal is normally 0 V with pulses to 5 VDC when data are sent on the bus. If it is constantly 5 VDC, check D0659 (most common error) and Q0653. Check that U0653 pin 43 is 5 VDC with pulses to ground while sending data.
- Then check U0658 (disconnect pins 1 and 12). If problem disappears and OPTION BW B+ circuit is OK (see 5.), replace U0658.
- If the OPTION SW B+ circuit is defect, D0668 should also be checked.

4.4 SB9600 data in comparator

- If the above voltages are correct, check U0656, Q0660 and Q0662.
- Finally check U0653.

4.5 Communication stops only with accessory on MIC Conn

- If bus communication stops only when an accessory is connected to the MIC Connector (P0651), check the OPTION SW B+ circuit (See 5.). The accessory is either defect or incompatible.

5 OPTION SW B+/Multiplexing of MIC Connector

Normal mode = No or simple microphone connected.

SB9600 mode = Smart accessory with serial bus connected.

5.1 SW B+ in Normal mode

- Make sure no accessory is connected to the MIC Connector (P0651).
- With power connected to the control head on J0650 pin 17 and 18, check that the DC voltage on P0651 pin 1 is approx. 12 VDC. If not check Q0664.

5.2 Multiplexer in normal position

- Check that the voltage on U0657/U0658/U0659 pin 10 is 5 VDC.
- If this fails check Q0664 and Q0665.

5.3 PTT input

- Check that the voltage on U0653 pin 9 changes from 5 VDC to approx. 1.7 VDC when P0651 pin 6 is connected to ground (equivalent to pressing PTT on a standard microphone).
- If this fails, check U0657.

5.4 Monitor input

- Check that the voltage on U0653 pin 9 changes from 5 VDC to approx. 3.3 VDC when P0651 pin 3 is connected to ground.
- If this fails check U0658.

5.5 AUX input

- Check that the voltage on U0653 pin 5 changes from 5 VDC to approx. 0 VDC when P0651 pin 7 is connected to ground.
- If this fails check U0659.

5.6 SW B+ in SB9600 mode

- Connect a 5.6 kohm resistor from P0651 pin 1 to ground (a keypad microphone can be used instead).
- Check that the DC voltage on P0651 pin 1 is still approx. 12 VDC.
- If not check Q0664.

5.7 SW B+ in SB9600 mode (high load)

- Connect a 68 ohms resistor from P0651 pin 1 to ground.
- Check that the DC voltage on P0651 pin 1 is still approx. 12 VDC.
- If not check Q0664.

5.8 Multiplexer in SB9600 position

- Connect a 5.6 kohm resistor from P0651 pin 1 to ground (a keypad microphone can be used instead).
- Check that the voltage on U0657/U0658/U0659 pin 10 is 0 VDC.
- If this fails check Q0664 and Q0665.

6 Volume Control

- Turn R0696 fully counter clockwise and then fully clockwise and verify the voltage on U0653 pin 14 goes from 0 V to 5 VDC.
- If not, check R0696.

7 Keypad

- Check that when pressing a key, both a column and a row input to U0653 pins 35-39 (rows) and 45-49 (columns) go low. The actual pins can be found on the schematic diagram.
- Clean the carbon pads with alcohol.
- Check carbon on rubber keypad. If defect, replace keypad.

8 Keypad backlight

8.1 All LEDs off or always on

- If all keypad LEDs are OFF (or ON but never turns off), check Q0650, Q0651 and Q0652.
- The backlight flip-flop can be turned on by connecting the base of Q0651 through a 4k7 ohms resistor to 5 VDC and turned off by connecting the base of Q0652 through a 4k7 ohms resistor to 5 VDC.

8.2 Light missing from some LEDs

- Check the LEDs.

9 LED indicators

- Check that the outputs from U0654 pin 6 (yellow), pin 9 (red) and pin 12 (green) change to 5 VDC when LED should go ON.

- Check Q0657 (yellow), Q0658 (red) and Q0659 (green).
- Check LEDs.

10 LCD backlight

10.1 All LEDs

If backlight cannot be turned on or off.

- Check that U0654 pins 16 and 19 are 5 VDC.
- If not, check U0654.
- Check that the voltage of base on Q0666 is 5 VDC.
- Check that the DC voltage of U0656 pin 1 is approx. 4.3 V.
- Check Q0667 and U0656.

10.2 One/some LEDs

- One LED is off. Check the LED.
- One row of LEDs is off. Find the LED that makes the short circuit.

11 LCD

11.1 Defect outside segments of display

- If the LCD has either light or dark areas outside the segment, the LCD glass is defect and must be replaced.

11.2 Missing segments

- Most likely caused by a bad connection between PCB and LCD. Disassemble and clean PCB and zebra connector with alcohol. LCD glass surfaces can be cleaned with distilled water with 3% ammonium chloride; never use alcohol on the LCD glass. If necessary replace the zebra connector or LCD.

11.3 Weak segments

- Segment brightness depends on the text displayed. Most likely caused by a short between the lines from display controller/driver to LCD. Disassemble and clean PCB and zebra connector with alcohol. If necessary replace the zebra connector.
- Check U0651.
- Check U0652 (model III only).

NOTE: When monitoring the signal on the LCD controller/driver outputs, a complex signal pattern is seen that jumps in 6 discrete voltages from -3V to +5V. Waveform depends on the contents of the display. Outputs are never steady. A signal can always be seen on a scope unless there is a short, or the LCD controller or driver is defect.

12 LCD bias voltage

If segments that should be on are weak, or segments that should be off are partly lit, the problem may be the bias voltage.

- Measure the LCD bias voltage (DC) between TP3 (+) and TP1 (-).
- The voltage should be approx. 8 VDC at ambient temperature.
- Check that U0654 pin 15 is high. If not check U0654.
- Check that U0655 pin 8 is approx. -5 VDC. If not check U0655.
- Check that U0653 pin 3 is approx. 2.5 VDC at ambient temperature. If not check R0742.
- Check that U0653 pin 20 is a square wave with a DC mean of approx. 3 VDC.
- If the bias regulation seems to run but the bias is too high or low this may be due to one of the following:
 - 1) Microprocessor has lost its factory adjustment parameters.
 - 2) Microprocessor is defect.
- Reprogramming of microprocessor or replacement of microprocessor requires a new factory adjustment currently not available in the RSS.

13 Secure keyloading

13.1 Secure keyloader sensing

- Connect P0651 pin 2 to ground. Check that DC voltage on U0653 pin 4 goes to 0 V. If not, check P0651, R0690, R0691 and C0667.

13.2 Multiplexer in keyload position

- Check that U0654 pin 5 goes to 5 VDC. If not check U0654.

13.3 Connections through multiplexer

- Check that P0651 pins 6, 3 and 7 are connected to J0650 pins 10, 12 and 11 respectively. If not check U0657, U0658 and U0659.
- Also check D0666, D0661, D0667, D0668, D0669, D0721 and D0722.

14 Rotary Switch (model II only)

- Turn rotary while monitoring normal radio operation.
- If rotary misses steps or jumps more than one step, replace R0697.

15 Microprocessor U0653

Replacement of U0653 requires a special factory programming and alignment (currently not available in the RSS (radio service software)).

Troubleshooting Chart 1-9, Clock Distribution

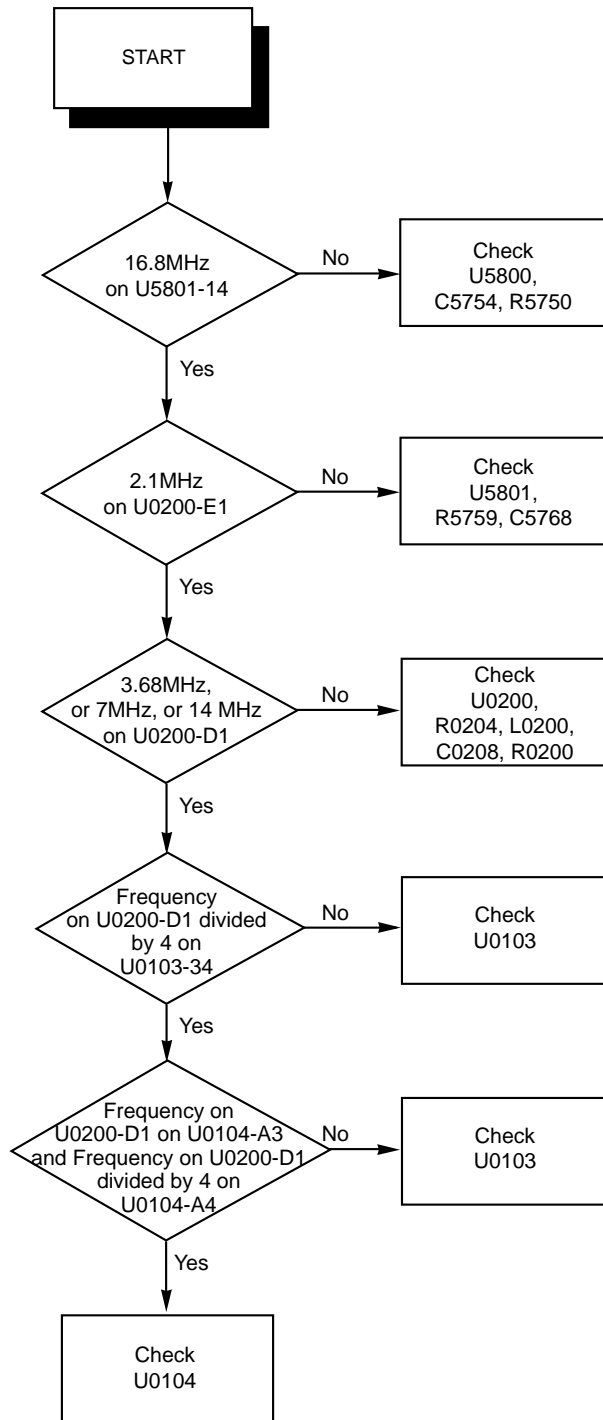



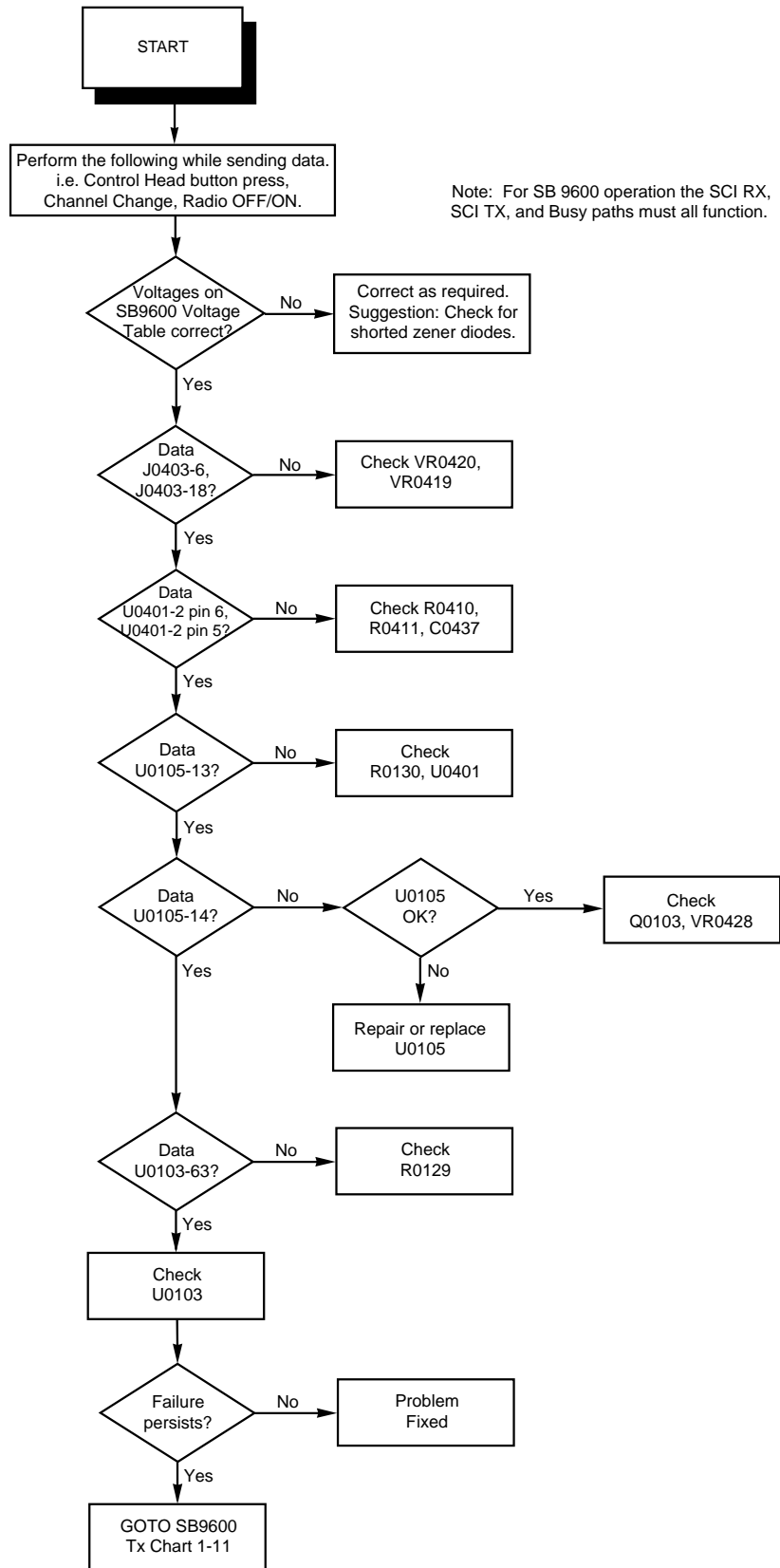

Troubleshooting Chart 1-10, SB9600 BUS RX

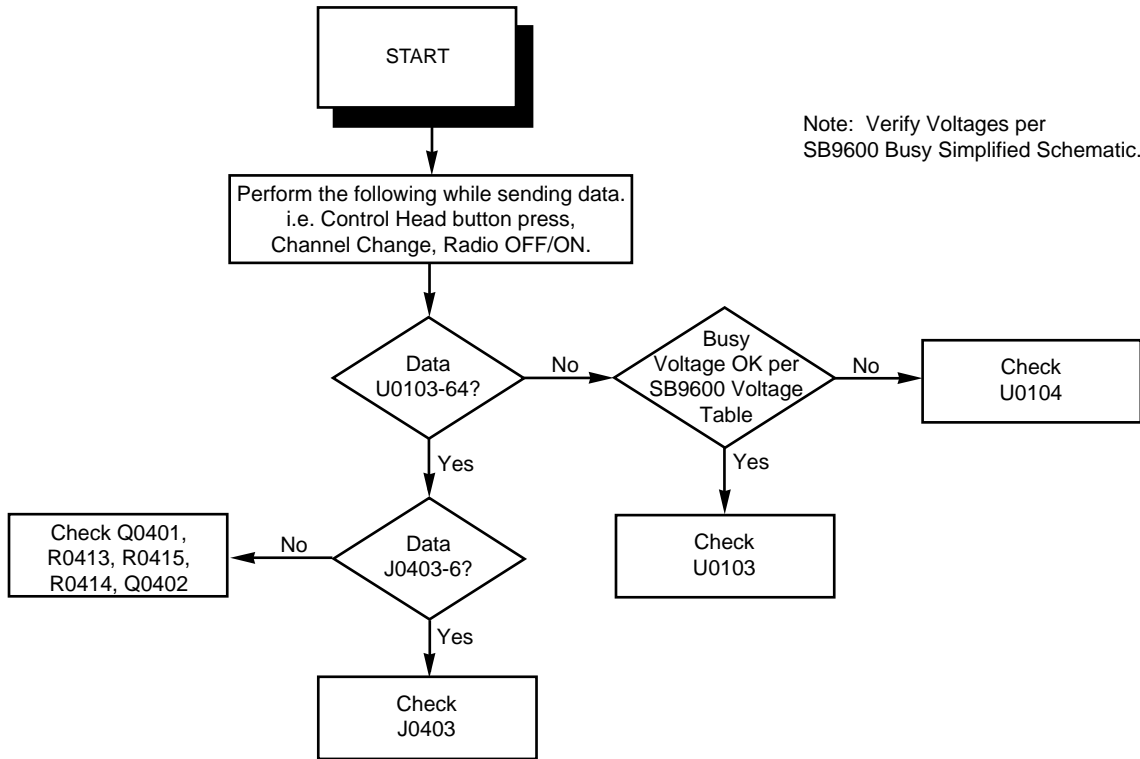

Troubleshooting Chart 1-11, SB9600 BUS RX

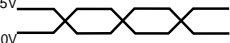

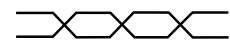
SB9600 Voltage Table for Charts 1-10 & 1-11

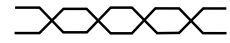
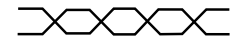
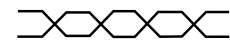
PIN	NOMINAL VOLTAGE	VOLTAGE DURING MESSAGING	FUNCTION
J0403-18	0		BUS -
J0403-6	5	 OPPOSITE POLARITY OF J0403-18	BUS +
J0403-5	5		BUSY
J0403-19	5	5	Not Used in Normal Operation
U0401-2, PIN 8	5	5	OP Amp Vdd
PIN 4	0	0	OP Amp GND
PIN 6	0		BUS -
PIN 5	5	 OPPOSITE POLARITY OF PIN 6	BUS +
PIN 7	5	 TRACKS STATE OF PIN 5	BUS_SCI
U0105-11	5	5	U0105 SCI_SELECT (Flash Prog/Normal Mode Select)
U0105-13 -14	5	 TRACKS STATE OF U0401-7 AND J0403-6	SCI
U0103-63	5	 TRACKS STATE OF U0401-7, J0403-6 AND U0105-13	SCI_RX
R0129	5		SCI_RX

SB9600 BUSY, Simplified Schematic for Charts 1-10 & 1-11

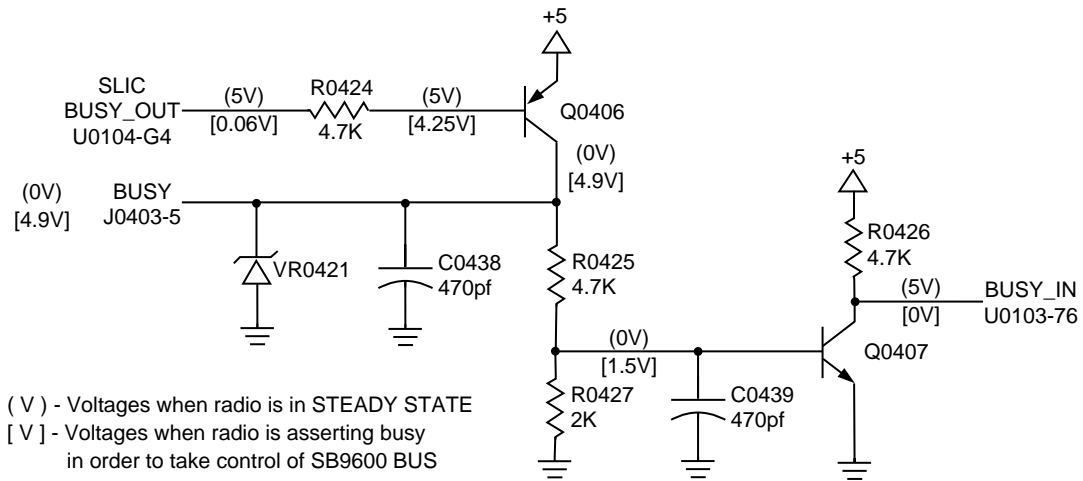

SB9600, Simplified Schematic for Charts 1-10 & 1-11

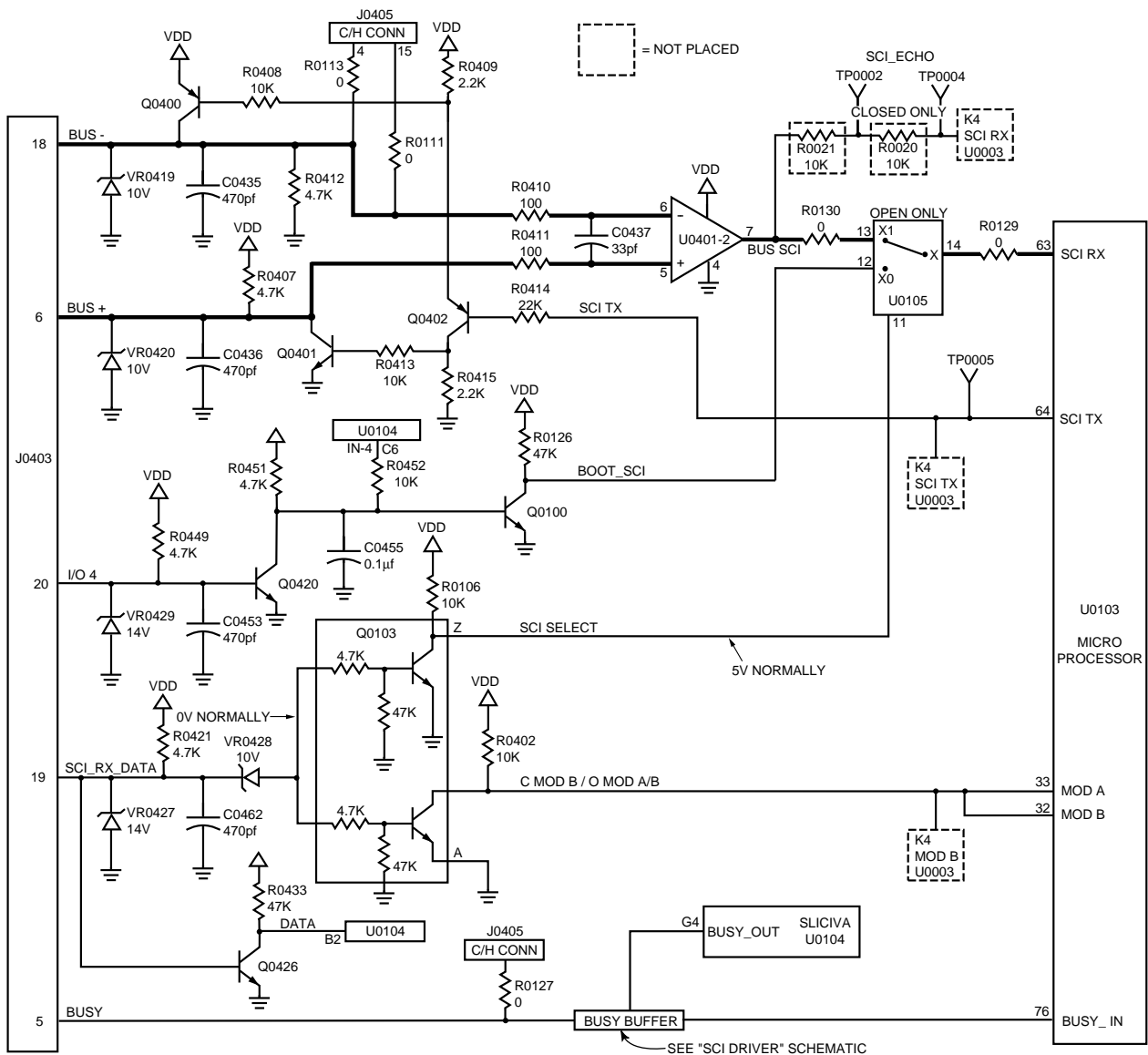

Troubleshooting Chart 1-12, GPIO

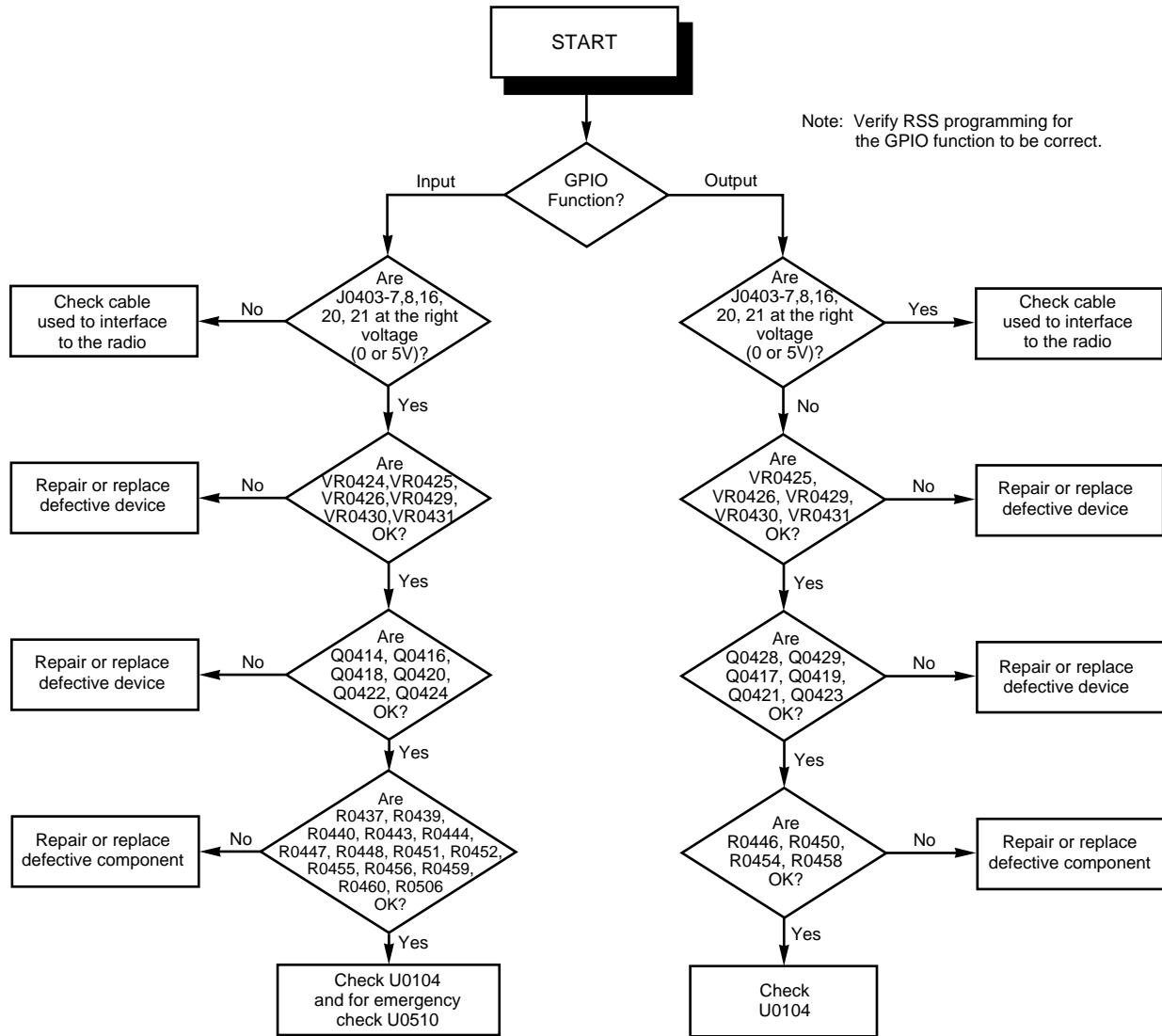

Troubleshooting Chart 1-13 (1 of 2), Power Control

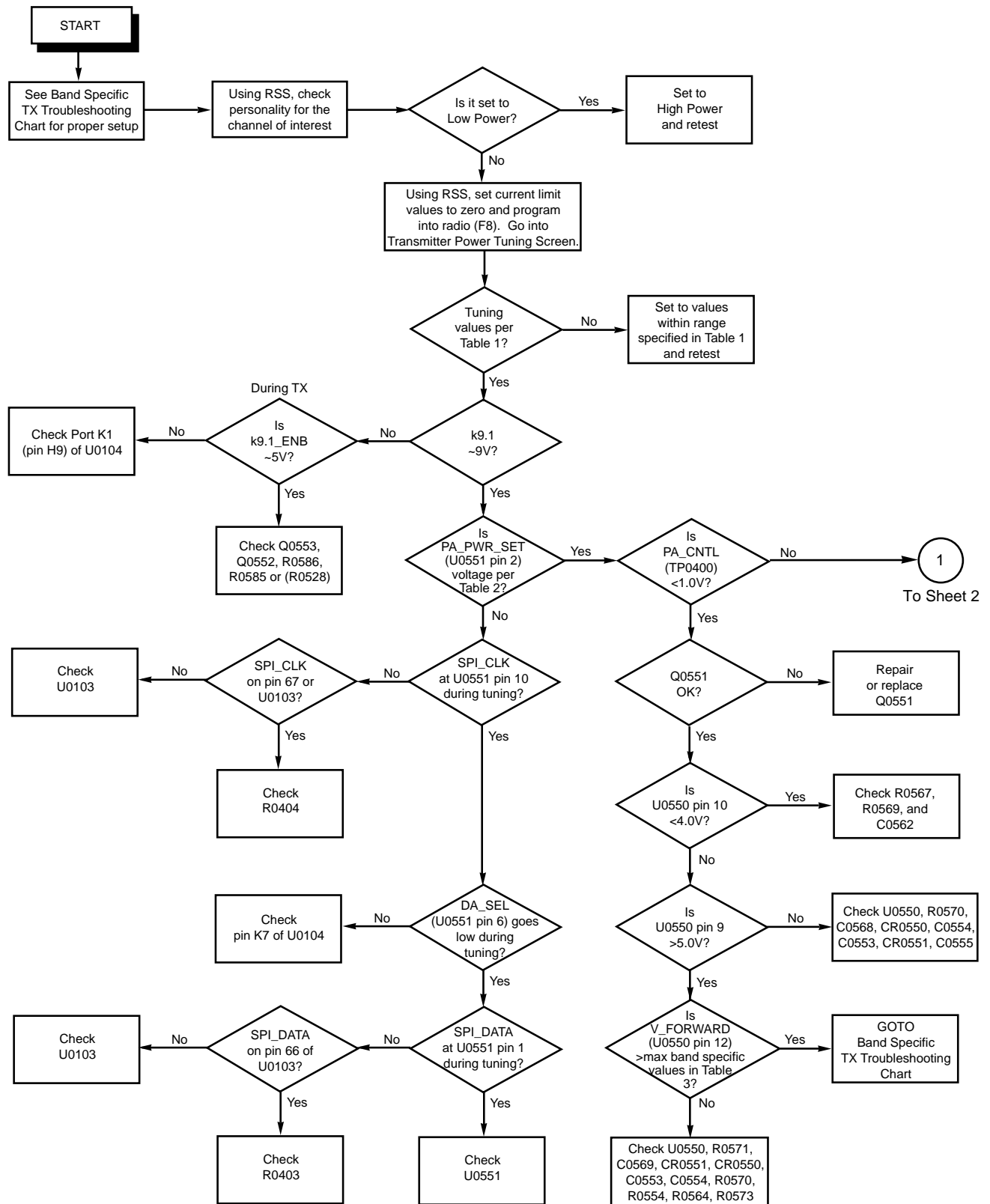

Troubleshooting Chart 1-13 (2 of 2), Power Control

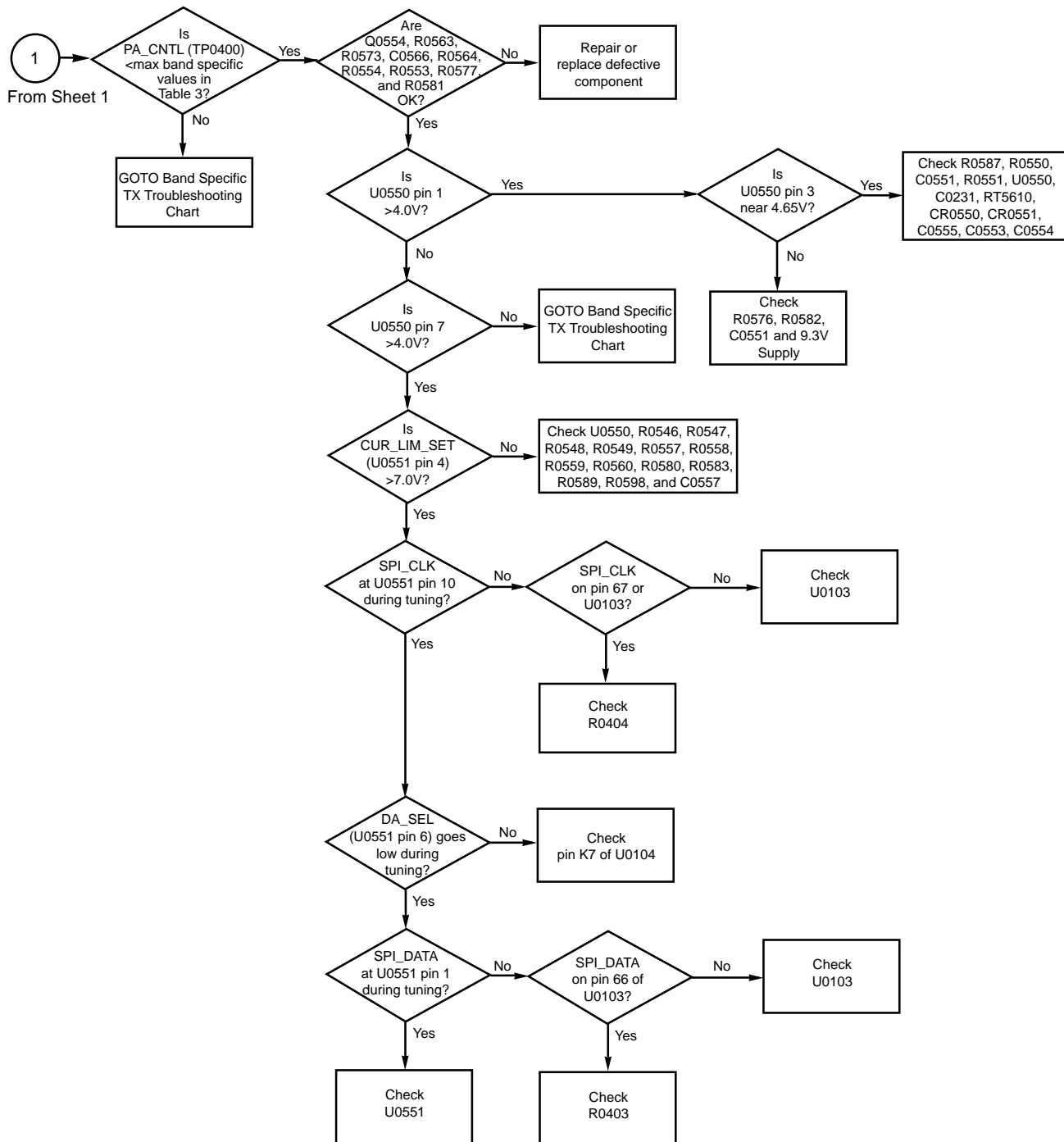



Diagrams and Parts Lists

Notes on Sheet Port Connections, Circuit Block Port Connections and Physical Connectors	10-2
Notes on Sheet Port Connections, Circuit Block Port Connections and Physical Connectors	10-2
Example of Transceiver Board Block Connection Diagram (110 Watt Radio)	10-3
Low Power Radios Exploded View Diagram and Parts List	10-4
Mid Power Radios Exploded View Diagram and Parts List	10-5
High Power Radios Exploded View Diagram and Parts List	10-6
Control Head Model I Exploded View Diagram and Parts List	10-7
Control Head Model II Exploded View Diagram and Parts List	10-8
Control Head Model III Exploded View Diagram and Parts List	10-9
Control Head Model I Component Locations and Parts List	10-10
Control Head Model I Schematic Diagram	10-11
Control Head Model II Component Locations and Parts List	10-12
Control Head Model II Schematic Diagram	10-13
Control Head Model III Component Locations and Parts List	10-14
Control Head Model III Schematic Diagram	10-15
Main Controller and Audio Power Amplifier and Voltage Regulators Component Locations	10-16
Controller Hierarchy Diagram	10-17
Main Controller Blocks Diagram	10-18
Controller, Microprocessor Schematic Diagram	10-19
Controller, Power Control Schematic Diagram	10-20
Controller, Audio Blocks Diagram	10-21
Controller, Hear Clear Schematic Diagram	10-22
Controller, ASFIC Schematic Diagram	10-23
Controller, Interface Blocks Diagram	10-24
Controller, IO RSSI Buffers Schematic Diagram	10-25
Controller, Emergency Ignition Schematic Diagram	10-26
Controller, SCI Drivers Schematic Diagram	10-27
Controller, IO Buffers Schematic Diagram	10-28
Controller, Audio Power Amplifier and Voltage Regulators, Low and Mid Power Schematic Diagram	10-29
Controller, Audio Power Amplifier and Voltage Regulators, High Power Schematic Diagram	10-30
Controller Parts List, Common Parts, Continued	10-32
Controller Parts List 800 MHz, 15W Unique	10-34
Controller Parts List, 800 MHz 35W Unique	10-35
Controller Parts List, 900 MHz 12W Unique	10-36
Controller Parts List, VHF 110W Unique	10-37
Controller Parts List, UHF1 110 W Unique	10-38
Controller Parts List, Non-Common Parts	10-39
Integrated Circuits with Pin-Out Names	10-40

Notes on Sheet Port Connections, Circuit Block Port Connections and Physical Connectors

On the schematic drawings there are three different signal connection markers as described below.

Sheet Port Connection

The Sheet connection appear as  or . These markers indicate that the signal shown on a given page continues to another schematic page. Typically the arrow direction indicates whether it is an input of output. These are used because the complete circuit scheme could not fit on one schematic sheet.

Circuit Block Port Connection

Besides the need to show page to page connections, the schematics also indicate interblock connections. While the radio is fabricated on one or two PCBs, it is actually composed of several functional circuit blocks which are interconnected. For example some signals from the receive front end block are connected to the Synthesizer circuit block. While there is no connector, and these two blocks are connected only by copper traces, the schematic system creates an imaginary point at which a runner for a given signal from the two blocks meet and assigns a connection number. This number typically appears on the schematic as IF#### with a  symbol shown. The interconnect diagram shows many of these blocks which are connected.

Physical Connector

Actual connectors such as the Accessory connector are shown with reference designators Jxxx or Pxxx. These represent physical connectors.

Schematic Hierarchy

Many of the MCS 2000 schematics are created in a hierarchical fashion. This is similar to a computer directory/subdirectory format. Like in a computer where there can be a mix of files and subdirectories under a given directory, some schematic sheets in the manual contain blocks or components, or both, in various sheets.

Pages that follow contain the component level breakdown of the blocks. Components refer to discrete electrical elements like resistors and capacitors. Blocks refer to a logical grouping of schematic components which appear in detail on following schematic sheets. This representation allows the reader to start with an overview of the schematic/circuit topology and navigate into more and more component level detail. Schematic blocks are represented by rectangular blocks shown by dashed outlines and contain the title of the schematic sheet which they represent.

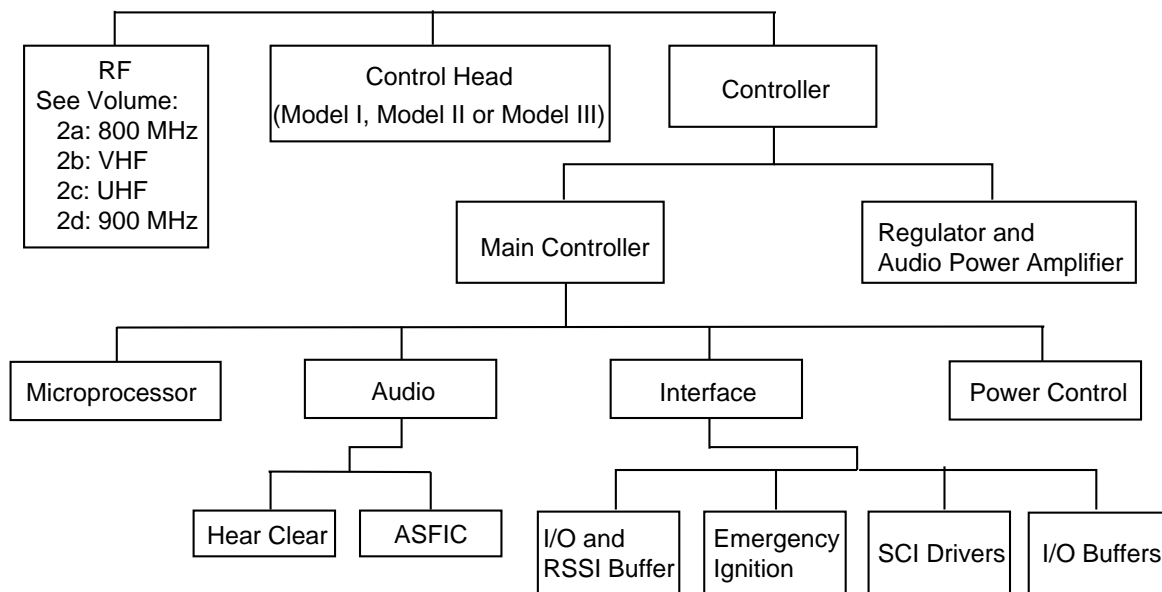

Figure 10-1 Schematic Diagram Hierarchy

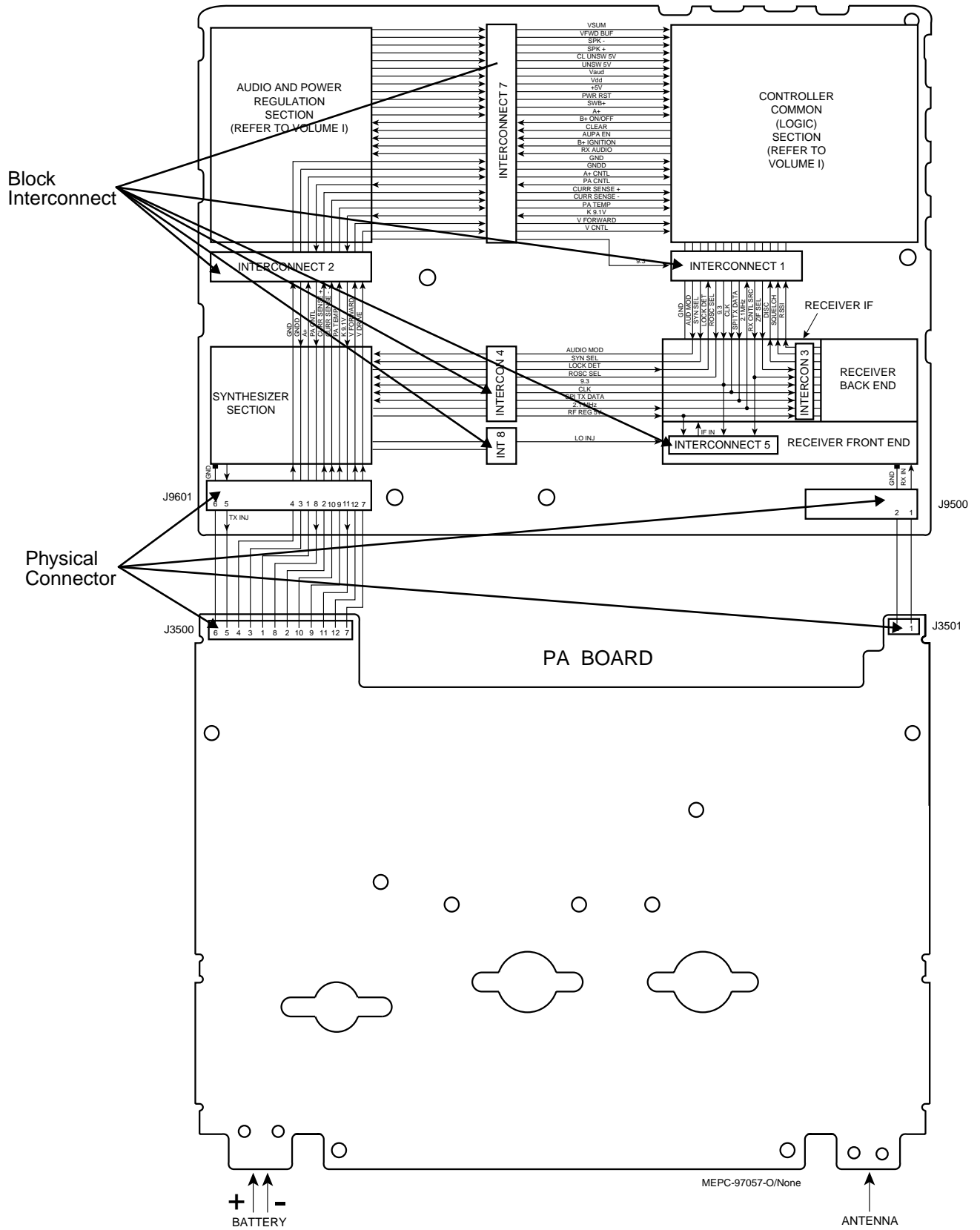
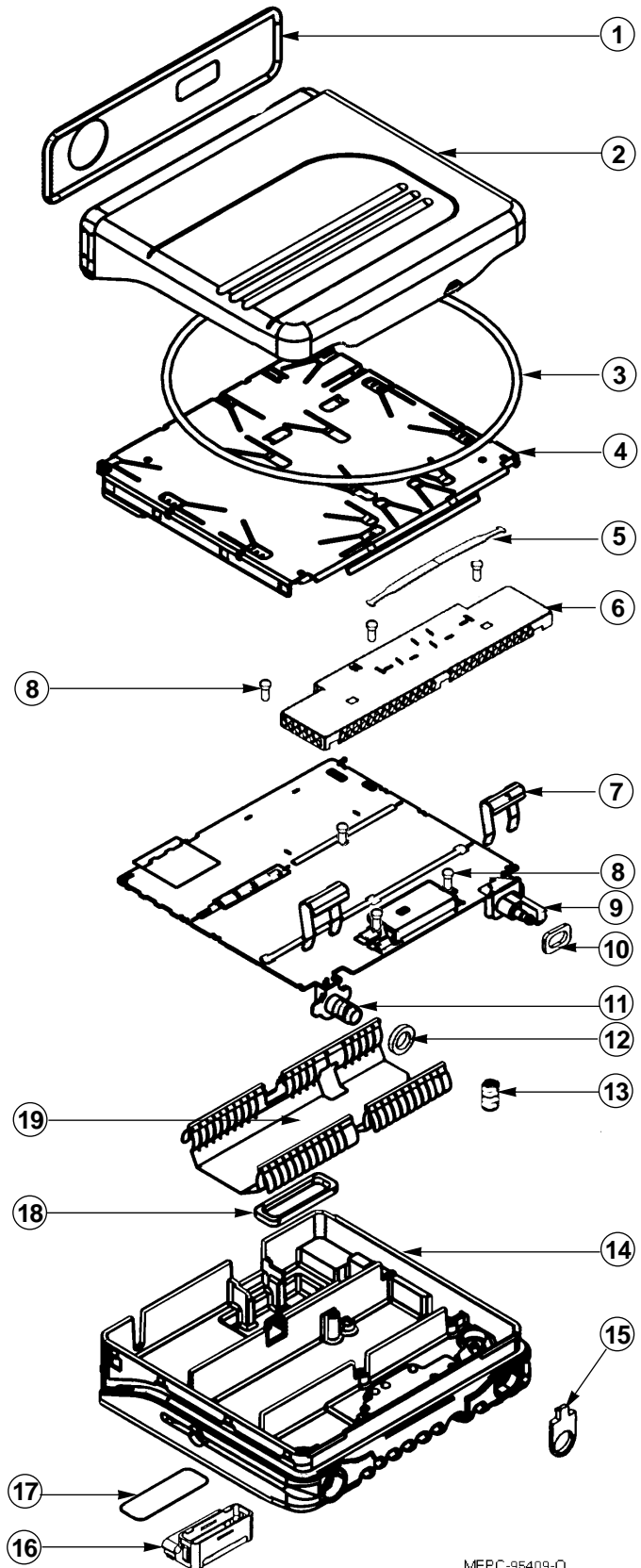

Figure 10-2 Example of Transceiver Board Block Connection Diagram (110 Watt Radio)

Exploded View Parts List, Low Power

ITEM NO.	MOTOROLA PART NO.	DESCRIPTION
1	3205931V01	Gasket, Front Cover
2	1505908V02	Top Cover
3	3205934V01	Gasket, Top Cover
4	2605652W02	Pressure Plate
5	5584300B04	Handle, 800 MHz only
6	2604802K01	PA Shield, 800 MHz only
7	4205938V01	Clip Spring, 2 pcs.
8	0310907C69	Screw, M3X0.5X10,6 pcs*
9	0905902V01	Power Connector
10	3205457Z02	Gasket, Power Connector
11	0905901V01	Antenna Connector
12	320547Z01	Gasket, Antenna Connector
13	4105783W01	Spring Diode
14	2705920V04	Chassis, Low Power
15	4205940V01	Retainer, Accessory Connector Cable
16	HLN6412	Accessory Connector
17	5405942V01	Label
18	3205935V01	Gasket, 25 D connector
19	2604555E01	Board Slot Shield, 800 MHz only

* Number of screws can vary depending on the model.



MEPC-95409-O

Exploded View Parts List, Mid Power

ITEM NO.	MOTOROLA PART NO.	DESCRIPTION
1	3205931V02	Gasket, Front Cover
2	1505764X01	Top Cover Assembly
3	3205082E97	Gasket, Top Cover
4	5584300B04	Handle
5	2605625X03	PA Shield
6	4205938V01	Clip Spring, 2 pcs.
7	0905902V04	Power Connector
8	3205457Z04	Gasket, Power Connector
9	0905901V06	Antenna Connector
10	3205457Z03	Gasket, Antenna Connector
11	2604693P01	Board Slot Shield, 800 MHz only
12	4205727X01	Clip, Audio PA
13	4105783W01	Spring Diode
14	4205627X01	Retainer, Accessory Connector Cable
15	HLN6412	Accessory Connector
16	3305873U04	Label, Rear Cover
17	2705816W01	Chassis, Mid Power
18	3205935V01	Gasket, 25 D connector
19	4205496Y01	Clip, PCB
20	0310907A20	Screw M3X0.5X10, 12 pcs.*
21	0310911A12	Screw M3x0.5x10, 6 pcs.*

* Number of screws can vary depending on the model.

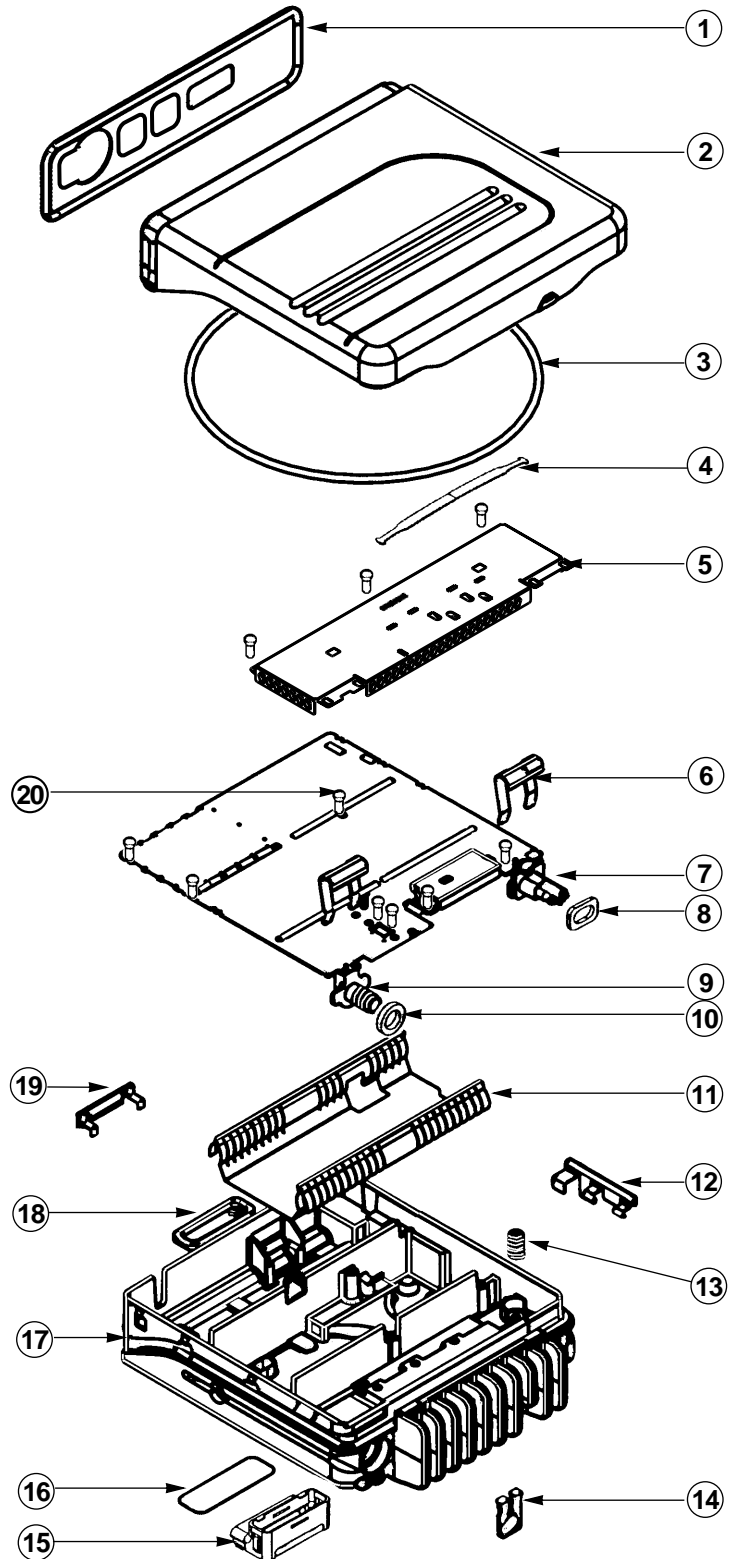

MEPC-95410-A

Exploded View Parts List, High Power

ITEM NO.	MOTOROLA PART NO.	DESCRIPTION
1	2705815W02	Chassis, High Power
2	3305179X01	Name Plate
3	4205938V01	Clip, Spring
4	0905902V04	Power Connector
4a	3205457Z04	Gasket, Power Connector
5	0905901V08	RF Connector
5a	3205457Z03	Gasket, RF Connector
6	HUD4021 or HUD4016 or HUE4018 or HUE4020	PA Board, VHF R1 PA Board, VHF R2 PA Board, UHF R1 PA Board, UHF R2
7	0310911A12	Screw M3X0.5X10, 6 pcs.
7a	0310907A20	Screw M3X0.5X10, VHF 16 pcs./UHF 18 pcs.
8	2605387Z02	PA Shield with Handle
9	1505849X01	Bottom Cover
10	HLN6412	Accessory Connector
11	3305873U04	Label, Rear Cover
12	32059789W01	Gasket, Remote Cable
13	2605265Y02	RF Shield with Handle
14	3205935V01	Gasket, 25 D Connector
15	4205169Y01	Audio PA Clip
16	2805347X02	Plug, High Spec.
17	HUD4019 or HUE4017	Transceiver Board, VHF Transceiver Board, UHF
18	3205934V01	Gasket, Top Cover
19	4105783W01	Spring Diode

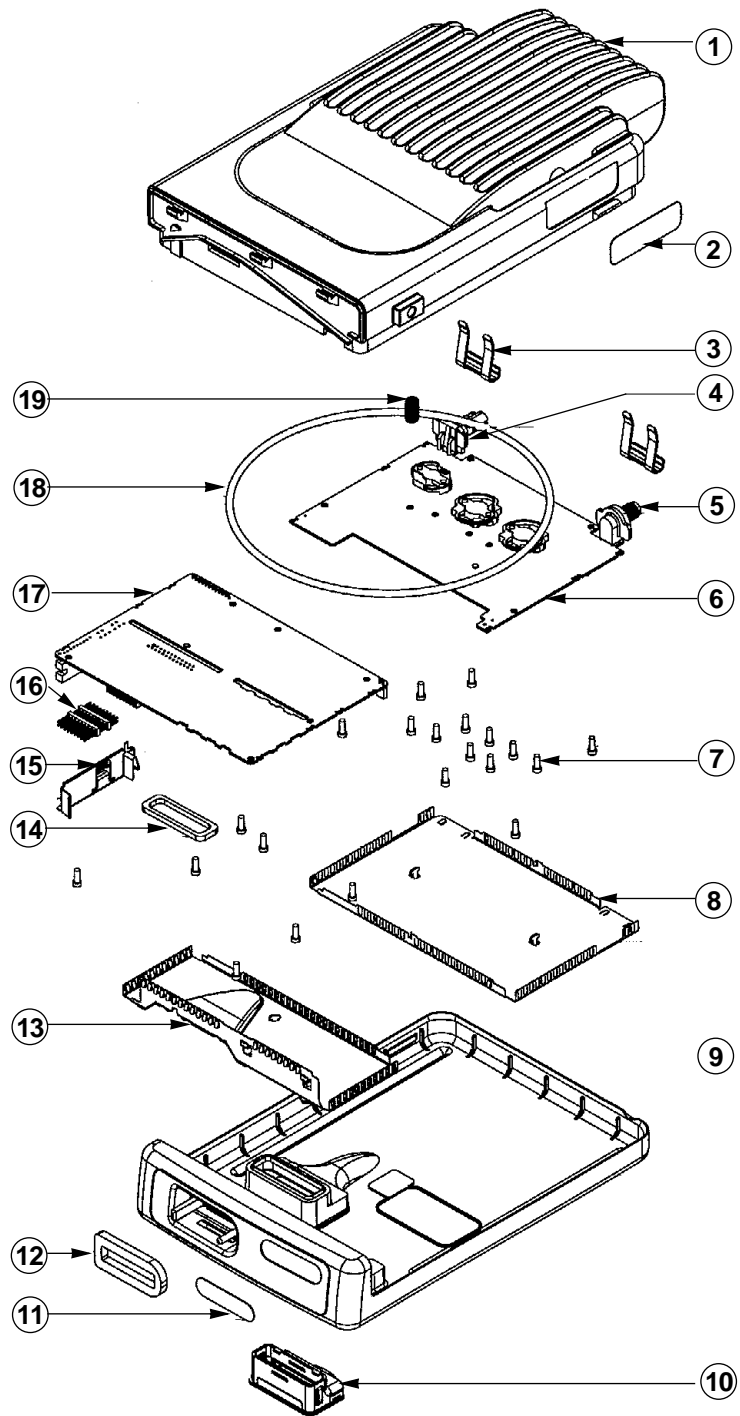

MEPC-95482-O

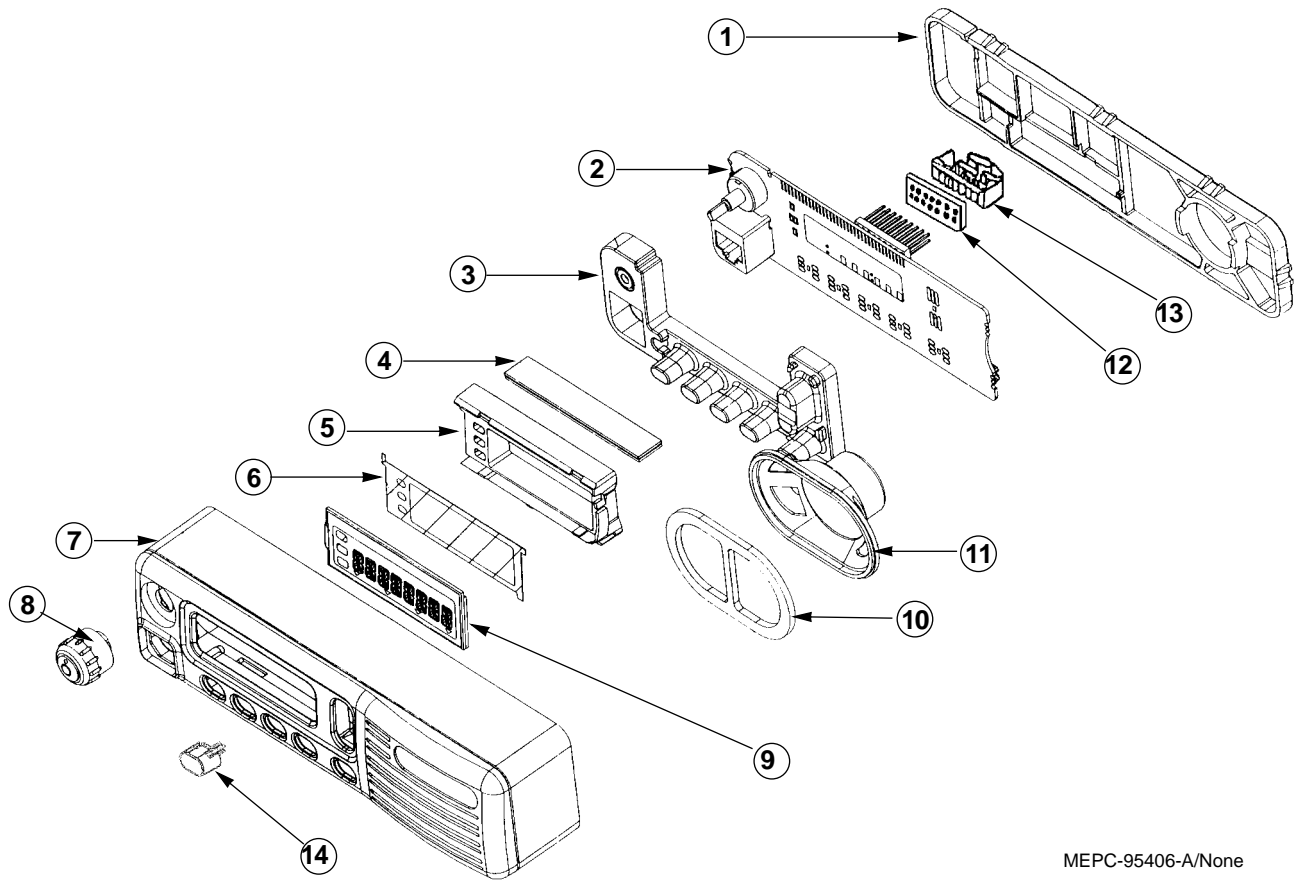

MEPC-95406-A/None

Exploded View Parts List, Control Head Model I

ITEM NO.	MOTOROLA PART NO.	DESCRIPTION
1	0702103U01	Frame Lock
2	0180757T74	Front End
3	7502101U05	Keypad, Elastomeric
4	2802102U01	Connector, Elastomeric
5	0702103U01	Frame, LCD
6	9102100U01	Colour Sheet, LCD
7	1502102U03	Housing, Control Head Model I
8	3605893W02	Volume Knob
9	7202100U02	LCD Glass
10	3205932V01	Gasket, Speaker
11	5005156Z02	Speaker
12	7608133K01	Ferrite Plate*
13	1580365K01	Shroud, white*
14	see Chapter 5	Replaceable Pushbutton

* Parts have been obsoleted on newer kits.

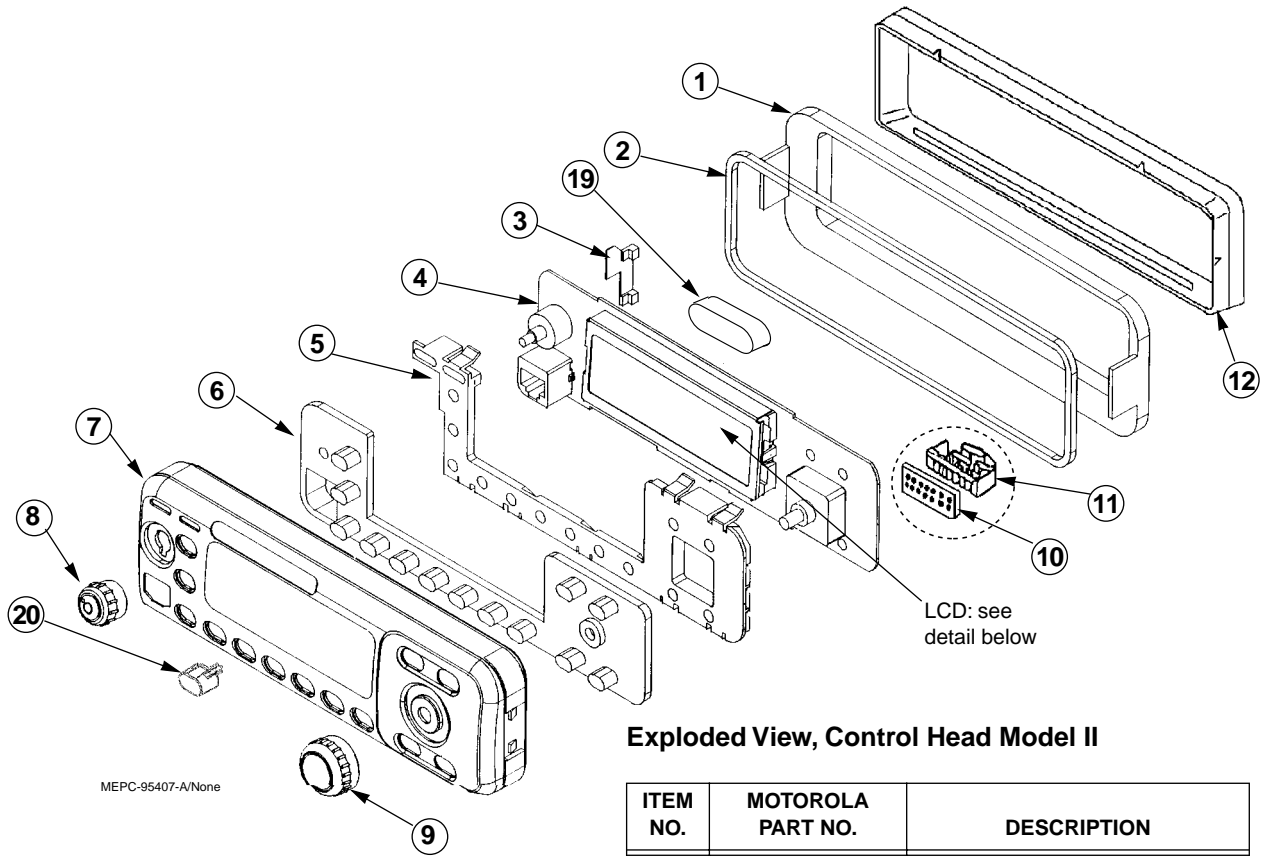

Exploded View, Control Head Model II

LCD Detail

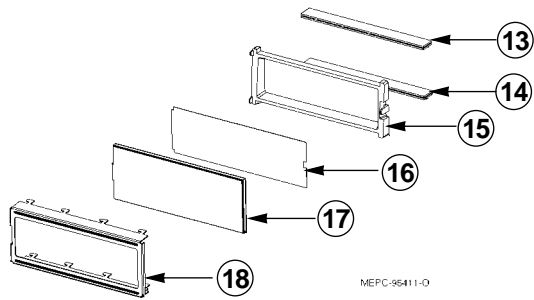

ITEM NO.	MOTOROLA PART NO.	DESCRIPTION
1	1502455Y04	Housing, Back
2	3202462Y03	Gasket, Housing
3	4602100U01	PCB Retainer
4	HCN4058	PCB Assembly*
5	6102082U04	Light Guide
6	7502565Y04	Keypad, std. with Text
6a	7505241Z03	Keypad, for use with Replaceable Pushbuttons
7	1502100U10	Housing, Control Head Model II
8	3605893W02	Volume Knob
9	3602100U01	Rotary Knob
10	7608133K01	Ferrite Plate†
11	1580365K01	Shroud, white ²
12	0704779P01	Retention Frame
13	2802102U01	Connector, Elastomeric - Gray
14	2802101U01	Connector, Elastomeric - Pink
15	0702103U03	Frame, LCD
16	9102102U01	Reflector Sheet
17	7202076U04	Display Glass
18	1302100U01	Bezel
19	3280542K01	Adhesive Pad
20	see Chapter 5	Replaceable Pushbutton

* Radios with SDLN4192 may use HCN4058 as replacement

† Parts have been eliminated

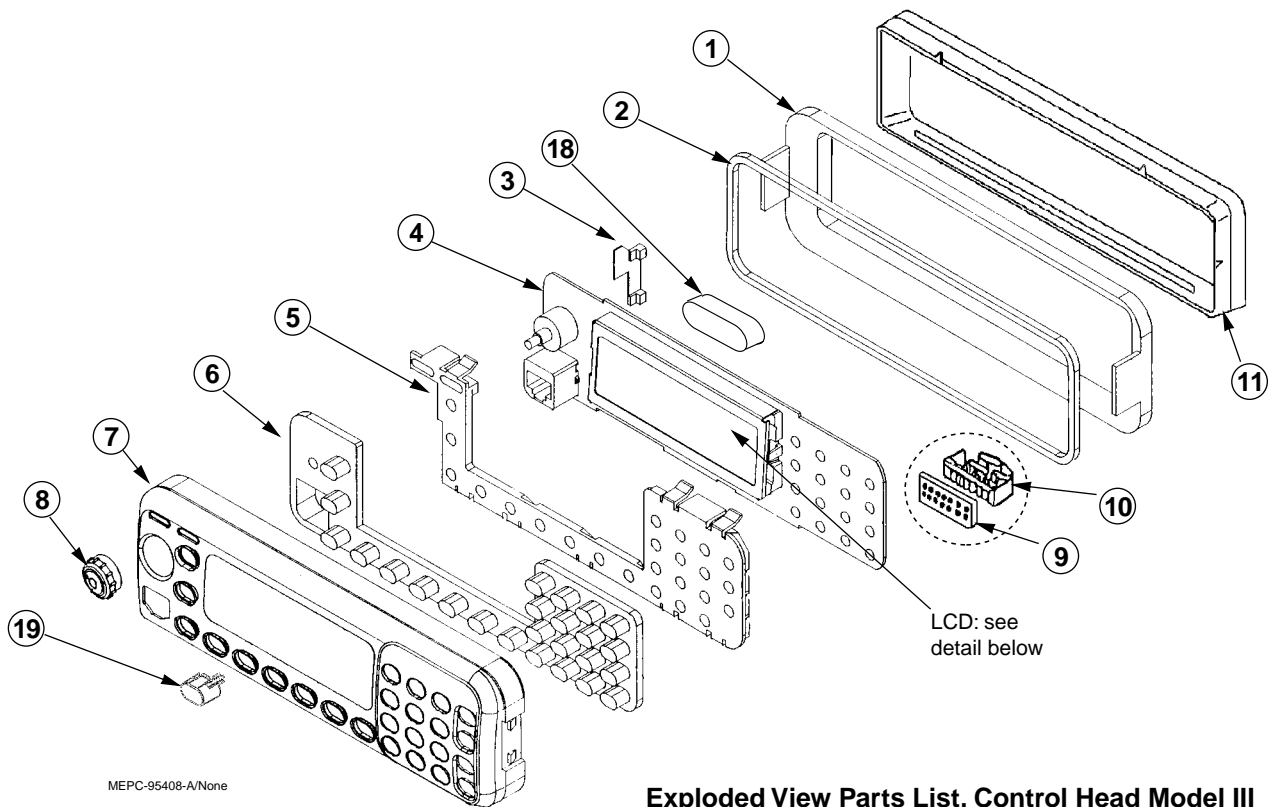

Exploded View Parts List, Control Head Model III

ITEM NO.	MOTOROLA PART NO.	DESCRIPTION
1	1502455Y04	Housing, Back
2	3202462Y03	Gasket, Housing
3	4602100U01	PCB Retainer
4	HCN4059	PCB Assembly ¹
5	6102082U04	Light Guide
6	7502566Y04	Keypad
6a	7505242Z03	Keypad, use with Replaceable Pushbuttons
7	1502100U08	Housing, Control Head Model III
8	3605893W02	Volume Knob
9	7608133K01	Ferrite Plate ²
10	1580365K01	Shroud, white ²
11	0704779P01	Retention Frame
12	2802102U01	Connector, Elastomeric - Gray
13	2802101U01	Connector, Elastomeric - Pink
14	0702084U02	Frame, LCD
15	9102102U01	Reflector Sheet
16	7202076U03	Display Glass
17	1302085U01	Bezel
18	3280542K01	Adhesive Pad
19	see Chapter 5	Replaceable Pushbutton

1 Radios with SDLN4193 may use HCN40589 as replacement
 2 Parts have been eliminated

LCD Detail

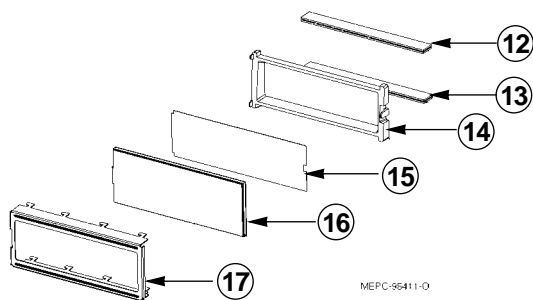

Control Head Model III

Exploded View Diagram and Parts List

LIGHT COMPONENTS SIDE

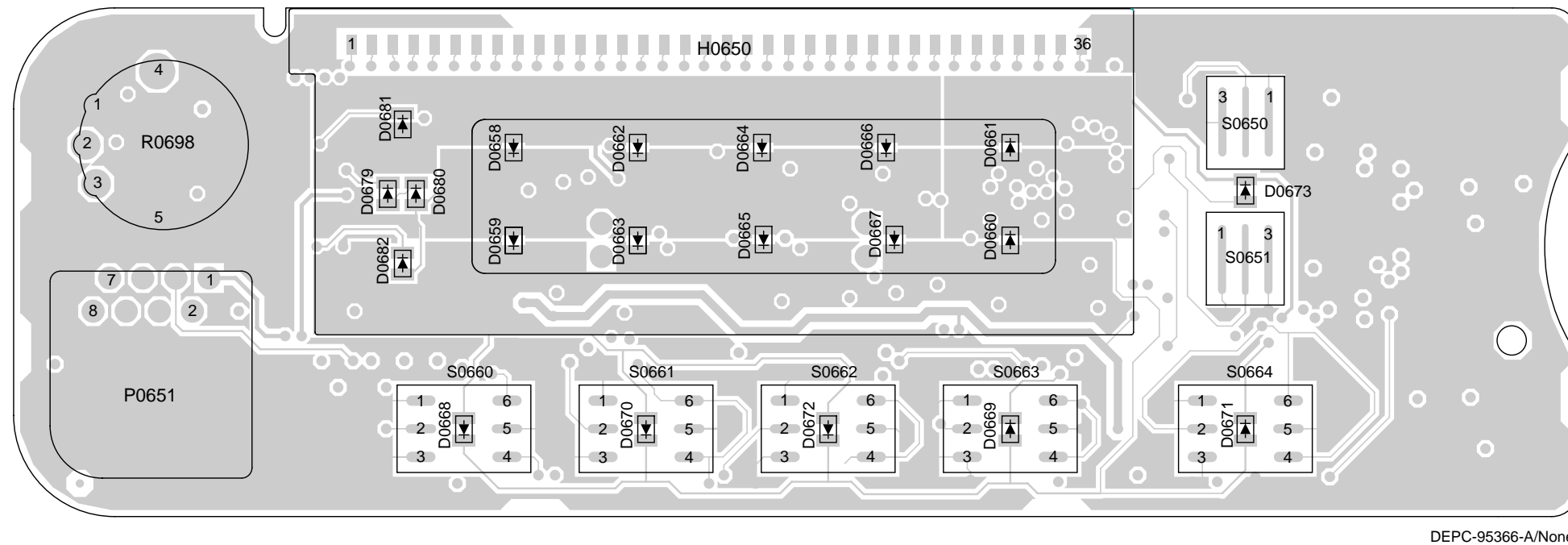

DEPC-95366-A/None

HEAVY COMPONENTS SIDE

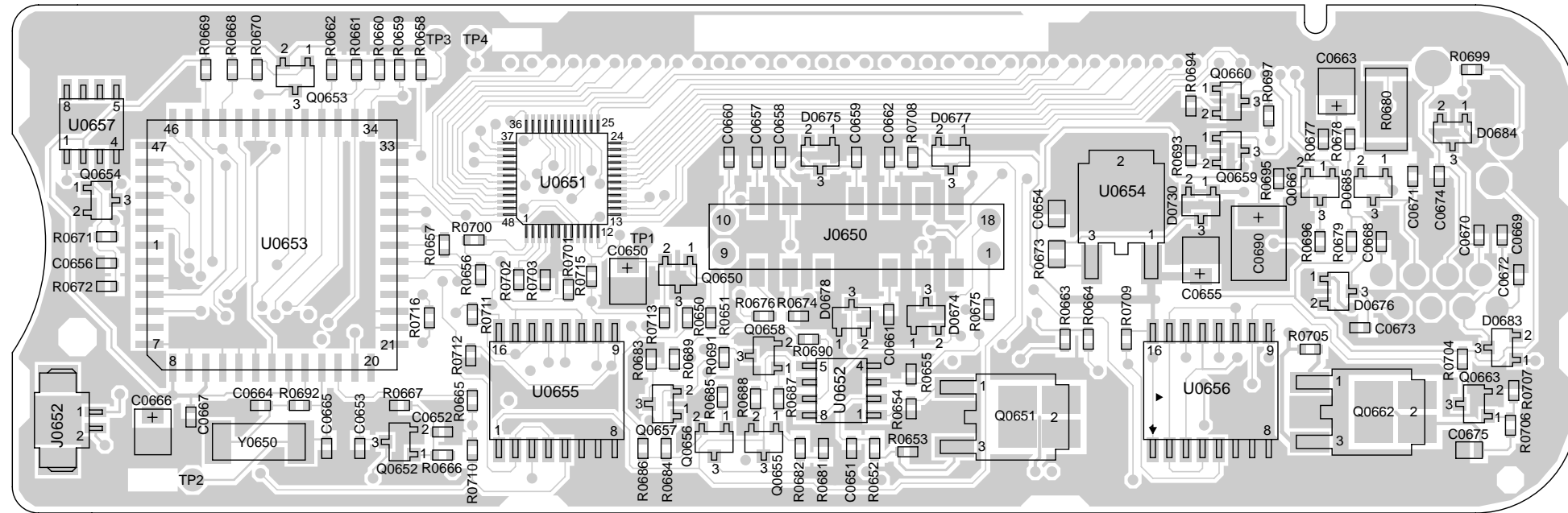

DEPC-95367-A/None

Control Head Model I Parts List 11/95

Reference Symbol	MOTOROLA Part Number	Description
		CAPACITORS, Fixed: unless otherwise stated
C0650	2311049J23	10uF
C0651	2113743K15	0.1uF
C0652	2113741F17	470pF
C0653	2113741F49	.01uF
C0654	2113743A23	0.22uF
C0655	2311049J23	10uF
C0656	2113741F17	470pF
C0657	2113741F17	470pF
C0658	2113741F17	470pF
C0659	2113741F17	470pF
C0660	2113741F17	470pF
C0661	2113741F17	470pF
C0662	2113741F17	470pF
C0663	2311049J12	4.7uF
C0664	2113740F39	33pF
C0665	2113740F39	33pF
C0666	2311049J23	10uF
C0667	2113743K15	0.1uF
C0668	2113741F17	470pF
C0669	2113741F17	470pF
C0670	2113741F17	470pF
C0671	2113741F17	470pF
C0672	2113741F17	470pF
C0673	2113741F17	470pF
C0674	2113741F17	470pF
C0675	2113743A23	.220uF
C0690 ¹	2311049A95	10uF
		DIODES:
D0658	4805729G75	LED GREEN
D0659	4805729G75	LED GREEN
D0660	4805729G75	LED GREEN
D0661	4805729G75	LED GREEN
D0662	4805729G75	LED GREEN
D0663	4805729G75	LED GREEN
D0664	4805729G75	LED GREEN
D0665	4805729G75	LED GREEN
D0666	4805729G75	LED GREEN
D0667	4805729G75	LED GREEN
D0668	4805729G75	LED GREEN
D0669	4805729G75	LED GREEN
D0670	4805729G75	LED GREEN
D0671	4805729G75	LED GREEN
D0672	4805729G75	LED GREEN
D0673	4805729G75	LED GREEN
D0674	4805729G75	LED GREEN
D0675	4805729G75	LED GREEN
D0676	4805729G75	LED GREEN
D0677	4805729G75	LED GREEN
D0678	4805729G75	LED GREEN
D0679	4805729G73	LED YEL
D0680	4805729G73	LED YEL
D0681	4805729G74	LED RED
D0682	4805729G75	LED GREEN
D0683	4813830A15	DIODE 5.6V
D0684	4813830A15	DIODE 5.6V
D0685	4813830A15	DIODE 5.6V
D0730 ¹	4805129M12	DIODE

Reference Symbol	MOTOROLA Part Number	Description
J0650	2805922V01	CONNECTORS: PLUG VERT
J0652	2809926G01	CONN SUR MT HDR
P0651	2805924V01	CONNECTOR MIC
		TRANSISTORS:
Q0650	4813824A17	PNP
Q0651	4813822A20	NPN
Q0652	4813824A10	NPN
Q0653	4813824A17	PNP
Q0654	4813824A10	NPN
Q0655	4813824A10	NPN
Q0656	4813824A17	PNP
Q0657	4813824A17	PNP
Q0658	4813824A10	NPN
Q0659	4813824A10	NPN
Q0660	4813824A10	NPN
Q0661	4813824A10	NPN
Q0662	4813822A08	PNP
Q0663	4813824A10	NPN
		RESISTORS, Fixed: Ω unless otherwise stated
R0650	0662057A59	2.7K
R0651	0662057A77	15K
R0652	0662057A73	10K
R0653	0662057A09	220
R0654	0662057A73	10K
R0655	0662057A61	3.3K
R0656	0662057A85	33K
R0657	0662057A85	33K
R0658	0662057A73	10K
R0659	0662057A73	10K
R0660	0662057A73	10K
R0661	0662057A73	10K
R0662	0662057A73	10K
R0663	0662057A73	10K
R0664	0662057A73	10K
R0665	0662057A89	47K
R0666	0662057A81	22K
R0667	0662057A73	10K
R0668	0662057A73	10K
R0669	0662057A65	4.7K
R0670	0662057A65	4.7K
R0671	0662057A65	4.7K
R0672	0662057A56	2K
R0673	0662057A01	10
R0674	0662057A01	10
R0676	0662057B47	0
R0677	0662057A89	47K
R0678	0662057A97	100K
R0679	0662057A65	4.7K
R0680	0680194M18	51
R0681	0662057A57	2.2K
R0682	0662057A73	10K
R0683	0662057A65	4.7K
R0684	0662057A73	10K
R0685	0662057A73	10K
R0686	0662057A57	2.2K
R0687	0662057A73	10K
R0688	0662057A73	10K
R0689	0662057A73	10K

Reference Symbol	MOTOROLA Part Number	Description
R0690	0662057A97	100K
R0691	0662057A73	10K
R0692	0662057B22	1M
R0693	0662057A39	390
R0694	0662057A41	470
R0695	0662057A39	390
R0696	0662057A37	330
R0697	0662057A37	330
R0698	1805911V01	Pot Vol
R0699	0662057A73	10K
R0700	0662057B16	560K
R0701	0662057A73	10K
R0702	0662057A73	10K
R0703	0662057A73	10K
R0704	0662057A73	10K
R0705	0662057A41	470
R0706	0662057A89	47K
R0707	0662057A81	22K
R0708	0662057A65	4.7K
R0709	0662057A65	4.7K
R0710	0662057A65	4.7K
R0711	0662057A65	4.7K
R0712	0662057A73	10K
R0713	0662057A53	1.5K
R0715	0662057A97	100K
R0716	0662057A97	100K
		INTEGRATED CIRCUITS:
U0651	5102109U01	LCD Segments driver
U0652	5113818A03	High Performance
U0653	5102110U03	IC UP OTP Prog. RCH C
U0654	5113816A07	Reg. 5V Pos.500MA MC78M05BD
U0655	5113805A84	IC Mux/Demux Dual 4-ch analog
U0656	5113805A84	IC Mux/Demux Dual 4-ch analog
		FILTERS:
Y0650	4880065M01	4.00 MHZ
	8405410Z01 or 8402112U01	NON REFERENCED ITEMS BOARD P.W.

¹ Not used on 8402112U01

For optimum performance, order replacement diodes, transistors, and circuit modules by Motorola part number only.

- When ordering crystals, specify carrier frequency, crystal frequency, crystal type number, and Motorola part number.
- Part value notations: $p=10^{-12}$, $n=10^{-9}$, $\mu=10^{-6}$, $m=10^{-3}$, $k=10^3$, $M=10^6$

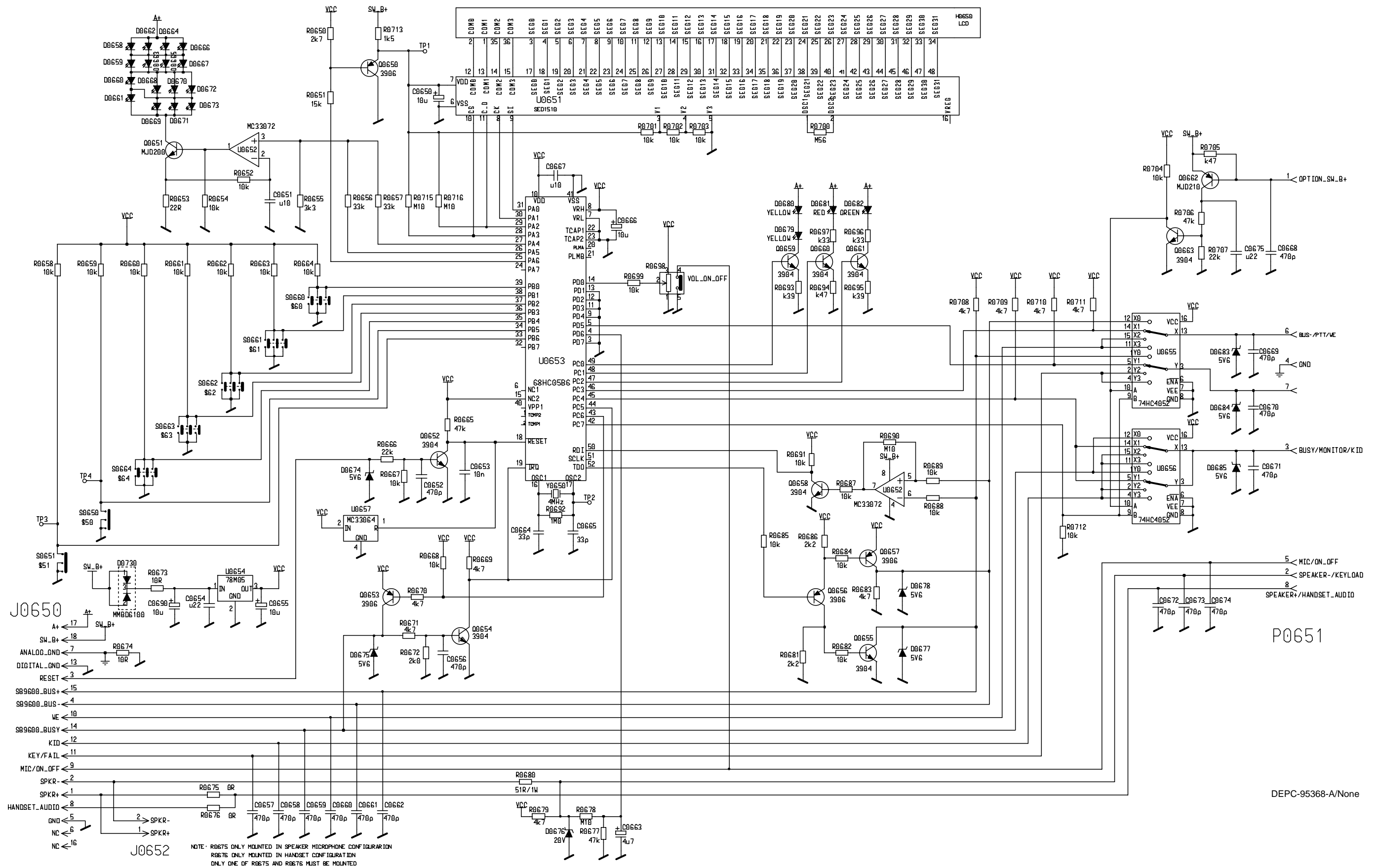

NOTE: R0675 ONLY MOUNTED IN SPEAKER MICROPHONE CONFIGURATION
 R0675 ONLY MOUNTED IN HANDSET CONFIGURATION
 ONLY ONE OF R0675 AND R0676 MUST BE MOUNTED