

# ASTRO® XTL™ 5000

700–800 MHz

Digital Mobile Radio

## Basic Service Manual



**MOTOROLA**

*intelligence everywhere™*







**MOTOROLA**  
*intelligence everywhere™*

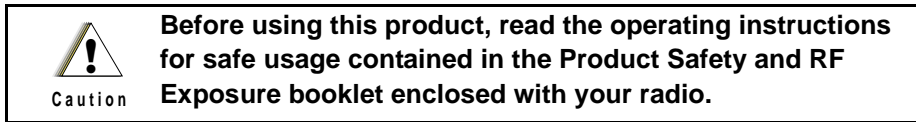
**ASTRO® XTL™ 5000**  
**700–800 MHz**  
**Digital Mobile Radio**  
**Basic Service Manual**

# Foreword

This manual covers all models of the ASTRO® XTL™ 5000 700–800 MHz Digital Mobile Radio (control head models W3, W4, W5, W7, and W9), unless otherwise specified. It includes all the information necessary to maintain peak product performance and maximum working time, using levels 1 and 2 maintenance procedures. This level of service goes down to the board replacement level and is typical of some local service centers, self-maintained customers, and distributors.

For details on radio operation or component-level troubleshooting, refer to the applicable manuals available separately. A list of related publications is provided in the section, “[Related Publications](#),” on page xii.

## Product Safety and RF Exposure Compliance



### ATTENTION!

**This radio is restricted to occupational use only to satisfy FCC RF energy exposure requirements. Before using this product, read the RF energy awareness information and operating instructions in the Product Safety and RF Exposure booklet enclosed with your radio (Motorola Publication part number 6881095C99) to ensure compliance with RF energy exposure limits.**

**For a list of Motorola-approved antennas, batteries, and other accessories, visit the following web site which lists approved accessories: <http://www.motorola.com/cgiss/index.shtml>**

## Manual Revisions

Changes which occur after this manual is printed are described in FMRs (Florida Manual Revisions). These FMRs provide complete replacement pages for all added, changed, and deleted items. To obtain FMRs, go to <https://businessonline.motorola.com>.

## Computer Software Copyrights

The Motorola products described in this manual may include copyrighted Motorola computer programs stored in semiconductor memories or other media. Laws in the United States and other countries preserve for Motorola certain exclusive rights for copyrighted computer programs, including, but not limited to, the exclusive right to copy or reproduce in any form the copyrighted computer program. Accordingly, any copyrighted Motorola computer programs contained in the Motorola products described in this manual may not be copied, reproduced, modified, reverse-engineered, or distributed in any manner without the express written permission of Motorola. Furthermore, the purchase of Motorola products shall not be deemed to grant either directly or by implication, estoppel, or otherwise, any license under the copyrights, patents or patent applications of Motorola, except for the normal non-exclusive license to use that arises by operation of law in the sale of a product.

## Document Copyrights

No duplication or distribution of this document or any portion thereof shall take place without the express written permission of Motorola. No part of this manual may be reproduced, distributed, or transmitted in any form or by any means, electronic or mechanical, for any purpose without the express written permission of Motorola.

## Disclaimer

The information in this document is carefully examined, and is believed to be entirely reliable. However, no responsibility is assumed for inaccuracies. Furthermore, Motorola reserves the right to make changes to any products herein to improve readability, function, or design. Motorola does not assume any liability arising out of the applications or use of any product or circuit described herein; nor does it cover any license under its patent rights nor the rights of others.

## Trademarks

MOTOROLA, the Stylized M logo, ASTRO, and FLASHport are registered in the US Patent & Trademark Office. All other product or service names are the property of their respective owners.

# Table of Contents

**Foreword ..... ii**

- Product Safety and RF Exposure Compliance ..... ii
- Manual Revisions ..... ii
- Computer Software Copyrights ..... ii
- Document Copyrights ..... ii
- Disclaimer ..... ii
- Trademarks ..... ii

**Commercial Warranty ..... xiii**

- Limited Warranty ..... xiii
  - MOTOROLA COMMUNICATION PRODUCTS ..... xiii
    - I. What This Warranty Covers And For How Long ..... xiii
    - II. General Provisions ..... xiii
    - III. State Law Rights ..... xiv
    - IV. How To Get Warranty Service ..... xiv
    - V. What This Warranty Does Not Cover ..... xiv
    - VI. Patent And Software Provisions ..... xv
    - VII. Governing Law ..... xv

**Model Numbering, Charts, and Specifications ..... xvii**

- Mobile Radio Model Numbering Scheme ..... xvii
- ASTRO XTL 5000 Motorcycle 3.5–35 Watt Model Chart ..... xviii
- ASTRO XTL 5000 3.5–35 Watt Model Chart ..... xix
- 700–800 MHz Radio Specifications ..... xxi

**Chapter 1 Introduction ..... 1-1**

- 1.1 Notations Used in This Manual ..... 1-1
- 1.2 Radio Description ..... 1-1
- 1.3 FLASHport® ..... 1-2
- 1.4 Control Head Descriptions ..... 1-2
  - 1.4.1 W3 Control Head ..... 1-3
  - 1.4.2 W3 Controls ..... 1-3
  - 1.4.3 W4, W5, W7, and W9 Controls Heads ..... 1-4
  - 1.4.4 W4, W5, W7, and W9 Controls ..... 1-5

**Chapter 2 Basic Maintenance ..... 2-1**

- 2.1 Introduction ..... 2-1
- 2.2 Preventive Maintenance ..... 2-1
  - 2.2.1 Inspection ..... 2-1
  - 2.2.2 Cleaning ..... 2-1
    - 2.2.2.1 Cleaning External Plastic Surfaces ..... 2-1

2.2.2.2	Cleaning Internal Circuit Boards and Components .....	2-2
2.2.3	General Radio Care and Handling Precautions .....	2-2
2.2.4	RF Power Amplifier (RF PA) Heatsinking .....	2-2
2.3	Handling Precautions .....	2-2

## **Chapter 3 Basic Theory of Operation ..... 3-1**

3.1	Introduction .....	3-1
3.2	General Overview .....	3-1
3.3	Controller Section .....	3-2
3.3.1	Introduction .....	3-2
3.3.2	Location .....	3-2
3.4	Daughtercard Module .....	3-2
3.4.1	Microprocessor .....	3-3
3.4.2	FLASH IC .....	3-3
3.4.3	SRAM IC .....	3-3
3.5	Surrounding Controller Region .....	3-3
3.5.1	Introduction .....	3-3
3.5.2	Voltage Regulation .....	3-4
3.5.3	Emergency .....	3-4
3.5.4	Front and Rear Connectors .....	3-4
3.5.4.1	Audio .....	3-5
3.5.4.2	Program Cable .....	3-5
3.5.4.3	SB9600 .....	3-5
3.5.4.4	VIP .....	3-5
3.5.4.5	RS232 .....	3-5
3.5.4.6	One-Wire .....	3-5
3.6	Analog Mode of Operation .....	3-6
3.6.1	Receive Operation .....	3-6
3.6.2	Transmit Operation .....	3-6
3.7	ASTRO Mode of Operation .....	3-6
3.8	Control Head Assembly .....	3-6
3.8.1	Display (W4, W5, and W7 Control Heads) .....	3-6
3.8.2	Display (W9 Control Head) .....	3-7
3.8.3	Vacuum Fluorescent (VF) Display Driver .....	3-7
3.8.4	Vacuum Fluorescent (VF) Voltage Source (W9) .....	3-7
3.8.5	Controls and Indicators .....	3-7
3.8.6	Status LEDs .....	3-7
3.8.7	Backlight LEDs .....	3-7
3.8.8	Vehicle Interface Port (VIP) .....	3-8
3.8.8.1	Remote-Mount .....	3-8
3.8.8.2	Dash-Mount .....	3-8
3.8.9	Control-Head Power Supplies .....	3-8
3.8.9.1	W3 Control Head .....	3-8
3.8.9.2	W4 Control Head .....	3-8
3.8.9.3	W5, W7, W9 Control Heads .....	3-8
3.8.10	Ignition Sense Circuits .....	3-8
3.9	Radio-Frequency Power Amplifier (RF PA) and Output Network (ON) .....	3-9
3.9.1	Gain Stages .....	3-9
3.9.2	Power Control .....	3-9
3.9.3	Circuit Protection .....	3-9
3.9.4	DC Interconnect .....	3-9
3.10	700–800 Receiver Overview .....	3-10

3.10.1	Receiver Front-End.....	3-10
3.10.2	Mixer.....	3-10
3.10.3	IF Circuitry .....	3-10
3.10.4	Abacus III Back-End .....	3-10
3.11	Frequency Generation Unit (FGU).....	3-11

**Chapter 4 Test Equipment, Service Aids, and Tools..... 4-1**

4.1	Recommended Test Equipment .....	4-1
4.2	Service Aids and Recommended Tools.....	4-2
4.3	Field Programming Equipment .....	4-3
4.3.1	XTL 5000 Field Programming.....	4-3
4.3.1.1	Dash-Mounted Radios .....	4-3
4.3.1.2	Remote-Mounted Radios.....	4-4
4.3.1.3	Field-Programming Items .....	4-4
4.3.1.4	W3 Control-Head Error Message .....	4-4

**Chapter 5 Performance Checks ..... 5-1**

5.1	Introduction .....	5-1
5.2	Test Setup .....	5-1
5.3	Test Mode.....	5-1
5.3.1	Entering Test Mode .....	5-1
5.3.2	RF Test Mode .....	5-3
5.3.3	Control Head Test Mode.....	5-4
5.4	Receiver Performance Checks .....	5-5
5.5	Transmitter Performance Checks .....	5-6

**Chapter 6 Radio Alignment Procedures..... 6-1**

6.1	Introduction .....	6-1
6.2	ASTRO XTL 5000 Tuner Software .....	6-1
6.3	Radio Information .....	6-3
6.4	Transmitter Alignments.....	6-3
6.4.1	PA Bias 1 Alignment .....	6-3
6.4.2	PA Bias 2 Alignment .....	6-4
6.4.3	PA Bias 3 Alignment .....	6-5
6.4.4	Reference Oscillator Alignment .....	6-6
6.4.5	Power Detector Calibration.....	6-8
6.4.6	Tx Power Characterization .....	6-9
6.4.7	Tx Current Limit .....	6-10
6.4.8	Tx Deviation Balance (Compensation) .....	6-12
6.4.9	Tx Deviation Limit .....	6-14
6.5	Performance Testing .....	6-16
6.5.1	Bit Error Rate (BER) Test .....	6-16
6.5.2	Transmitter Test Pattern .....	6-17
6.6	Mic Sensitivity Calibration.....	6-18

**Chapter 7 Encryption ..... 7-1**

7.1	Universal Crypto Module Kits.....	7-1
7.1.1	Secure Interface Boards .....	7-1
7.1.2	Secure Dispatch Operation.....	7-1
7.1.3	Secure Emergency Operation.....	7-2
7.2	Load an Encryption Key.....	7-2
7.2.1	W3 Control Head .....	7-2
7.2.2	W4, W5, W7, and W9 Control Heads .....	7-3
7.3	Advanced Secure Operation.....	7-3
7.3.1	Multikey Operation .....	7-3
7.4	Erase a Key .....	7-3
7.4.1	W3 Control Head .....	7-4
7.4.2	W4, W5, W7, and W9 Control Heads .....	7-5
7.5	Erase a Single Key (W3 Control Head) .....	7-6
7.6	Erase All Keys.....	7-6
7.6.1	W3 Control Head .....	7-6
7.6.2	W4, W5, W7, and W9 Control Heads .....	7-7
7.7	Over-the-Air Rekeying .....	7-7
7.7.1	W3 Control Head .....	7-8
7.7.2	W4, W5, W7, and W9 Control Heads .....	7-9

## **Chapter 8 Disassembly/Reassembly Procedures ..... 8-1**

8.1	Introduction .....	8-1
8.2	Replacement Procedures .....	8-1
8.2.1	Required Tools and Supplies.....	8-1
8.2.2	Control Head Boards Disassembly/Reassembly .....	8-2
8.2.2.1	W3 Disassembly .....	8-2
8.2.2.2	W3 Reassembly.....	8-3
8.2.2.3	W4, W5, and W7 Disassembly .....	8-4
8.2.2.4	W4, W5, and W7 Reassembly.....	8-5
8.2.2.5	W9 Disassembly .....	8-6
8.2.2.6	W9 Reassembly.....	8-6
8.2.3	Remote Back Housing Interface Board Disassembly/Reassembly .....	8-7
8.2.3.1	W4, W5, and W7 Disassembly .....	8-7
8.2.3.2	W4, W5, and W7 Reassembly.....	8-7
8.2.4	Remote Interconnect Board Assembly/Reassembly.....	8-7
8.2.4.1	Assembly .....	8-7
8.2.4.2	Reassembly .....	8-8
8.2.5	Radio Disassembly .....	8-8
8.2.6	Radio Reassembly.....	8-19
8.3	Chassis Thermal Pad Replacement Procedure.....	8-30
8.4	Fastener Torque Chart.....	8-32

## **Chapter 9 Basic Troubleshooting ..... 9-1**

9.1	Introduction .....	9-1
9.1.1	J2 Accessory Connector.....	9-1
9.1.2	I/O Disclaimer .....	9-3
9.1.3	Microphone Bias .....	9-4
9.1.4	Audio PA Out Bias .....	9-5
9.1.5	High Power RF Precaution .....	9-5
9.2	Replacement Board Procedures.....	9-5



9.3	Power-Up Error Codes .....	9-5
9.4	Operational Error Codes .....	9-7
9.5	Transmitter Troubleshooting .....	9-7
9.6	Receiver Troubleshooting .....	9-8

**Chapter 10 Functional Block Diagrams and Connectors ..... 10-1**

10.1	XTL 5000 Functional Block Diagram .....	10-2
10.2	Radio Connectors .....	10-3
10.3	Radio Connector Locations .....	10-4
10.4	Radio Connector Locations (cont.) .....	10-4
10.5	Control Head Cabling Diagram .....	10-5
10.6	Control Head Connector .....	10-6
10.7	Connector Naming Schemes .....	10-7

**Chapter 11 Exploded Views and Parts Lists ..... 11-1**

11.1	W3 Hand-Held Control Head Exploded View .....	11-2
11.2	W4 Rotary Control Head Exploded View .....	11-3
11.3	W5 and W7 Pushbutton Control Head Exploded View .....	11-4
11.4	W9 Pushbutton Control Head Exploded View .....	11-5
11.5	XTL 5000 (3.5-35 W) Radio Exploded View .....	11-6
11.6	Motorcycle Interconnect Board and Assembly .....	11-7
11.7	Interconnect Board and Assembly .....	11-7
11.8	Motorcycle Radio Remote-Mount Control Head with Speaker and Microphone .....	11-8
11.9	Handlebar Installation (Control Head and Speaker Mounted Together) .....	11-9
11.10	Handlebar Installation (Control Head and Speaker Mounted Separately) .....	11-9
11.11	Fuel-Tank Console Installation (Control Head and Speaker Mounted Together) .....	11-10
11.12	Fuel-Tank Console Installation (Control Head and Speaker Mounted Separately) .....	11-10
11.13	HMN1062_ Motorcycle Microphone .....	11-11
11.14	HSN6003_ Motorcycle Weather-Resistant Speaker .....	11-11
11.15	Motorcycle Weather-Resistant Radio Enclosure .....	11-12
11.16	Motorcycle Universal Mounting Plate .....	11-13
11.17	Small Pushbutton Parts .....	11-13
11.18	Large Pushbutton Parts .....	11-13

**Appendix A Replacement Parts Ordering.....A-1**

A.1	Basic Ordering Information .....	A-1
A.2	Motorola Online .....	A-1
A.3	Mail Orders .....	A-1
A.4	Telephone Orders .....	A-1
A.5	Fax Orders .....	A-2
A.6	Parts Identification .....	A-2
A.7	Product Customer Service .....	A-2

**Appendix B Environmental Information ..... B-1**

**Glossary ..... Glossary-1**

---

**Index..... Index-i**

## List of Figures

Figure 1-1. Mobile Radio Model Numbering Scheme .....	xvii
Figure 1-1. W3 Hand-Held Control Head .....	1-3
Figure 1-2. Typical W4 Rotary Control Head.....	1-4
Figure 1-3. Typical W5 Limited Keypad Control Head .....	1-4
Figure 1-4. Typical W7 Full Keypad Control Head .....	1-4
Figure 1-5. Typical W9 Full Keypad Control Head .....	1-5
Figure 3-1. Controller Sections.....	3-2
Figure 3-2. Frequency Generation Unit Diagram .....	3-11
Figure 5-1. Performance Checks Test Setup .....	5-1
Figure 5-2. W4 Control-Head Key-Closure Displays.....	5-4
Figure 5-3. W5 and W7 Control-Head Key-Closure Displays .....	5-5
Figure 5-4. W9 Control-Head Key-Closure Displays.....	5-5
Figure 6-1. Radio Alignment Test Setup.....	6-1
Figure 6-2. Tuner Main Menu.....	6-2
Figure 6-3. Radio Information Screen .....	6-3
Figure 6-4. PA Bias 1 Alignment Screen .....	6-4
Figure 6-5. PA Bias 2 Alignment Screen .....	6-5
Figure 6-6. PA Bias 3 Alignment Screen .....	6-6
Figure 6-7. Reference Oscillator Window.....	6-7
Figure 6-8. Power Detection Calibration Alignment Screen .....	6-8
Figure 6-9. Tx Power Characterization Alignment Screen .....	6-9
Figure 6-10. Tx Current Limit Alignment Screen .....	6-11
Figure 6-11. Tx Deviation Balance (Compensation) Alignment Screen .....	6-13
Figure 6-12. Tx Deviation Limit Alignment Screen .....	6-15
Figure 6-13. Bit Error Rate Screen.....	6-16
Figure 6-14. Transmitter Test Pattern Screen .....	6-17
Figure 6-15. Mic Sensitivity Calibration Screen.....	6-18
Figure 8-1. W4 Rotary Control-Head Assembly Screw and Snap Sequence .....	8-4
Figure 8-2. W5 and W7 Pushbutton Control-Head Assembly Screw Sequence.....	8-5
Figure 8-3. Removing the Front Panel Screws .....	8-8
Figure 8-4. Removing the Control Head.....	8-9
Figure 8-5. Removing the Flex (Control-Head Connector).....	8-9
Figure 8-6. Removing the Headbridge .....	8-10
Figure 8-7. Removing the Flex (Main-Board Connector) .....	8-10
Figure 8-8. Control-Head Flex (Removed).....	8-11
Figure 8-9. Headbridge Seal (Removed) .....	8-11
Figure 8-10. Removing the Secure Interface Board.....	8-12
Figure 8-11. Removing the Top Cover Screws.....	8-13
Figure 8-12. Lifting the Top Cover .....	8-13
Figure 8-13. Removing the Top Cover .....	8-14
Figure 8-14. Removing the J2 Rear Accessory Flex from the Main Board .....	8-14
Figure 8-15. Removing the PA Screws .....	8-15
Figure 8-16. Removing the RF/DC Retention Clip (J2 Connector Side) .....	8-16
Figure 8-17. Removing the RF/DC Retention Clip (Antenna Connector Side).....	8-16
Figure 8-18. Pushing Up the Main Board.....	8-17
Figure 8-19. Lifting Out the Main Board .....	8-17
Figure 8-20. Removing the J2 Rear Accessory Connector.....	8-18
Figure 8-21. Inspecting the Chassis Shield Gasketing and Thermal Pads .....	8-19
Figure 8-22. Inserting the J2 Rear Accessory Connector .....	8-20
Figure 8-23. Inserting the Main Board into the Chassis .....	8-21

Figure 8-24. Inserting the RF/DC Retention Clip (DC Side) .....	8-22
Figure 8-25. Inserting the RF/DC Retention Clip (RF Side) .....	8-22
Figure 8-26. Connecting the J2 Rear Accessory Connector Flex to the Main Board .....	8-23
Figure 8-27. Installing the PA Screws.....	8-24
Figure 8-28. Inspecting the Thermal Pad and Installing the Cover Main Seal .....	8-24
Figure 8-29. Preparing to Place the Top Cover on the Chassis .....	8-25
Figure 8-30. Securing the Top Cover to the Chassis.....	8-25
Figure 8-31. Installing the Secure Interface Board .....	8-26
Figure 8-32. Installing the Headbridge Seal .....	8-27
Figure 8-33. Installing the Control-Head Flex in the Transceiver .....	8-27
Figure 8-34. Installing the Headbridge on the Transceiver.....	8-28
Figure 8-35. Installing the Control-Head Flex on the Control Head.....	8-28
Figure 8-36. Inserting the Control Head Into the Transceiver .....	8-29
Figure 8-37. Installing the Control-Head Screws.....	8-29
Figure 8-38. Chassis Thermal Pad Locations .....	8-30
Figure 9-1. J2 Accessory Connector Pin-Out Arrangement .....	9-1
Figure 10-1. ASTRO XTL 5000 Functional Block Diagram .....	10-2
Figure 10-2. J0103 Remote-Mount Control Head Connector.....	10-3
Figure 10-3. J5 Control Cable for Remote-Mount Control Head .....	10-3
Figure 10-4. J6 Radio Operations Connector.....	10-3
Figure 10-5. J3 Remote-Control Cable Accessory Connector .....	10-3
Figure 10-6. J2 Rear Accessory Connector .....	10-3
Figure 10-7. P104 Microphone Jack .....	10-3
Figure 10-8. Dash-Mount Radio Connector Locations .....	10-4
Figure 10-9. Remote-Mount Radio Connector Locations .....	10-4
Figure 10-10. Main Board Connector Locations - Side 1.....	10-4
Figure 10-11. Main Board Connector Locations - Side 2 .....	10-4
Figure 10-12. Control Head Cabling Diagram .....	10-5
Figure 10-13. Control Head 50-pin Connector .....	10-6
Figure 10-14. XTL 5000 Radio Connector Naming Scheme .....	10-7
Figure 11-1. W3 Hand-Held Control Head Exploded View.....	11-2
Figure 11-2. W4 Rotary Control Head Exploded View .....	11-3
Figure 11-3. W5 and W7 Pushbutton Control Head Exploded View .....	11-4
Figure 11-4. W9 Pushbutton Control Head Exploded View.....	11-5
Figure 11-5. XTL 5000 (3.5-35 W) Radio Exploded View .....	11-6
Figure 11-6. Motorcycle Interconnect Board and Assembly Exploded View .....	11-7
Figure 11-7. Interconnect Board and Assembly Exploded View .....	11-7
Figure 11-8. Motorcycle Radio Remote-Mount Control Head with Speaker and Microphone.....	11-8
Figure 11-9. Handlebar Installation (Control Head and Speaker Mounted Together) Exploded View.....	11-9
Figure 11-10. Handlebar Installation (Control Head and Speaker Mounted Separately) Exploded View .....	11-9
Figure 11-11. Fuel-Tank Console Installation (Control Head and Speaker Mounted Together) Exploded View .....	11-10
Figure 11-12. Fuel-Tank Console Installation (Control Head and Speaker Mounted Separately) Exploded View .....	11-10
Figure 11-13. HMN1062_ Motorcycle Microphone .....	11-11
Figure 11-14. HSN6003_ Motorcycle Weather-Resistant Speaker .....	11-11
Figure 11-15. Motorcycle Weather-Resistant Radio Enclosure .....	11-12
Figure 11-16. Motorcycle Universal Mounting Plate Exploded View .....	11-13

## List of Tables

Table 1-1.	Control Head Basic Features.....	1-2
Table 4-1.	Recommended Motorola Test Equipment.....	4-1
Table 4-2.	Wattmeter Plug-In Elements .....	4-1
Table 4-3.	Recommended Non-Motorola Test Equipment.....	4-2
Table 4-4.	Service Aids for XTL 5000 Board-Level Troubleshooting .....	4-2
Table 4-5.	Recommended Motorola Tools for Board-Level Troubleshooting.....	4-3
Table 4-6.	Recommended Non-Motorola Tools for Board-Level Troubleshooting .....	4-3
Table 4-7.	XTL 5000 Radio Field-Programming Items.....	4-4
Table 5-1.	Test-Mode Displays .....	5-2
Table 5-2.	Test Frequencies .....	5-3
Table 5-3.	Signaling Types .....	5-4
Table 5-4.	Receiver Performance Checks .....	5-5
Table 5-5.	Transmitter Performance Checks .....	5-6
Table 6-1.	PA Bias 1 Alignment RF Power Amplifier Devices.....	6-3
Table 6-2.	Power Supply Voltage Settings.....	6-3
Table 6-3.	PA Bias 1 Alignment Device Bias Current .....	6-4
Table 6-4.	PA Bias 2 Alignment Amplifier Devices.....	6-4
Table 6-5.	Power Supply Voltage Settings.....	6-4
Table 6-6.	PA Bias 2 Alignment Device Bias Current .....	6-5
Table 6-7.	PA Bias 3 Alignment Amplifier Devices.....	6-5
Table 6-8.	Power Supply Voltage Settings.....	6-5
Table 6-9.	PA Bias 3 Alignment Device Bias Current .....	6-6
Table 6-10.	Reference Oscillator Alignment .....	6-8
Table 6-11.	Power Supply Voltage Settings.....	6-8
Table 6-12.	Power Supply Voltage Settings.....	6-9
Table 6-13.	Power Supply Voltage Settings.....	6-10
Table 6-14.	Transmit Current Limit Offset.....	6-11
Table 6-15.	Transmit Current Limit Devices.....	6-12
Table 6-16.	Bit Error Rate Test Fields.....	6-16
Table 6-17.	Transmitter Test Pattern Fields .....	6-17
Table 7-1.	UCM Kit Listing .....	7-1
Table 7-2.	Secure Interface Board Kits.....	7-1
Table 8-1.	Required Tools and Supplies .....	8-1
Table 8-2.	Chassis Thermal Pad Parts .....	8-30
Table 8-3.	Fastener Torque Chart.....	8-32
Table 9-1.	J2 Accessory Connector Signal and Voltage Descriptions .....	9-1
Table 9-2.	Normal Operation Range and ESD Clamping Voltages.....	9-3
Table 9-3.	Power-Up Error Codes.....	9-5
Table 9-4.	Operational Error Codes.....	9-7
Table 9-5.	Transmitter Troubleshooting Chart .....	9-7
Table 9-6.	Receiver Troubleshooting Chart .....	9-8
Table 10-1.	Table of Functional Block Diagrams and Connectors.....	10-1
Table 11-1.	Table of Exploded Views .....	11-1
Table 11-2.	W3 Hand-Held Control Head Exploded View Parts List .....	11-2
Table 11-3.	W4 Rotary Control Head Parts List.....	11-3
Table 11-4.	W5 and W7 Pushbutton Control Head Parts List.....	11-4
Table 11-5.	W9 Pushbutton Control Head Parts List .....	11-5
Table 11-6.	XTL 5000 (3.5-35W) Radio Parts List.....	11-6
Table 11-7.	Motorcycle Interconnect Board and Assembly Parts List.....	11-7
Table 11-8.	Interconnect Board and Assembly Parts List.....	11-7
Table 11-9.	Motorcycle Radio Remote-Mount Control Head with Speaker and Microphone Parts List.....	11-8
Table 11-10.	Handlebar Installation (Control Head and Speaker Mounted Together) Parts List .....	11-9
Table 11-11.	Handlebar Installation (Control Head and Speaker Mounted Separately) Parts List .....	11-9
Table 11-12.	Fuel-Tank Console Installation (Control Head and Speaker Mounted Together) Parts List.....	11-10

---

Table 11-13. Fuel-Tank Console Installation (Control Head and Speaker Mounted Separately) Parts List .....	11-10
Table 11-14. HMN1062_ Motorcycle Microphone Parts List.....	11-11
Table 11-15. HSN6003_ Motorcycle Weather-Resistant Speaker Parts List .....	11-11
Table 11-16. Motorcycle Weather-Resistant Radio Enclosure Parts List (Enclosure Parts) .....	11-12
Table 11-17. Motorcycle Weather-Resistant Radio Enclosure Parts List (Mounting Parts) .....	11-12
Table 11-18. Motorcycle Universal Mounting Plate Parts List.....	11-13
Table 11-19. Small Pushbutton Parts List.....	11-13
Table 11-20. Large Pushbutton Parts List.....	11-13

## Related Publications

ASTRO XTL 5000 Digital Mobile Radio with W3 Control Head User's Guide .....	6881096C67
ASTRO XTL 5000 Digital Mobile Radio with W4, W5, W7, and W9 Control Heads User's Guide .....	6881096C68
ASTRO XTL 5000 Digital Mobile Radio Installation Manual .....	6881096C72
ASTRO XTL 5000 Digital Mobile Radio Detailed Service Manual .....	6818096C74
CPS Programming Installation Guide .....	6881095C44
KVL 3000 User's Manual .....	6881131E16

# Commercial Warranty

## Limited Warranty

### MOTOROLA COMMUNICATION PRODUCTS

#### I. What This Warranty Covers And For How Long

MOTOROLA INC. ("MOTOROLA") warrants the MOTOROLA manufactured Communication Products listed below ("Product") against defects in material and workmanship under normal use and service for a period of time from the date of purchase as scheduled below:

ASTRO XTL 5000	One (1) Year
Product Accessories	One (1) Year

Motorola, at its option, will at no charge either repair the Product (with new or reconditioned parts), replace it (with a new or reconditioned Product), or refund the purchase price of the Product during the warranty period provided it is returned in accordance with the terms of this warranty. Replaced parts or boards are warranted for the balance of the original applicable warranty period. All replaced parts of Product shall become the property of MOTOROLA.

This express limited warranty is extended by MOTOROLA to the original end user purchaser only and is not assignable or transferable to any other party. This is the complete warranty for the Product manufactured by MOTOROLA. MOTOROLA assumes no obligations or liability for additions or modifications to this warranty unless made in writing and signed by an officer of MOTOROLA. Unless made in a separate agreement between MOTOROLA and the original end user purchaser, MOTOROLA does not warrant the installation, maintenance or service of the Product.

MOTOROLA cannot be responsible in any way for any ancillary equipment not furnished by MOTOROLA which is attached to or used in connection with the Product, or for operation of the Product with any ancillary equipment, and all such equipment is expressly excluded from this warranty. Because each system which may use the Product is unique, MOTOROLA disclaims liability for range, coverage, or operation of the system as a whole under this warranty.

#### II. General Provisions

This warranty sets forth the full extent of MOTOROLA'S responsibilities regarding the Product. Repair, replacement or refund of the purchase price, at MOTOROLA's option, is the exclusive remedy. THIS WARRANTY IS GIVEN IN LIEU OF ALL OTHER EXPRESS WARRANTIES. IMPLIED WARRANTIES, INCLUDING WITHOUT LIMITATION, IMPLIED WARRANTIES OF MERCHANTABILITY AND FITNESS FOR A PARTICULAR PURPOSE, ARE LIMITED TO THE DURATION OF THIS LIMITED WARRANTY. IN NO EVENT SHALL MOTOROLA BE LIABLE FOR DAMAGES IN EXCESS OF THE PURCHASE PRICE OF THE PRODUCT, FOR ANY LOSS OF USE, LOSS OF TIME, INCONVENIENCE, COMMERCIAL LOSS, LOST PROFITS OR SAVINGS OR OTHER INCIDENTAL, SPECIAL OR CONSEQUENTIAL DAMAGES ARISING OUT OF THE USE OR INABILITY TO USE SUCH PRODUCT, TO THE FULL EXTENT SUCH MAY BE DISCLAIMED BY LAW.

### III. State Law Rights

SOME STATES DO NOT ALLOW THE EXCLUSION OR LIMITATION OF INCIDENTAL OR CONSEQUENTIAL DAMAGES OR LIMITATION ON HOW LONG AN IMPLIED WARRANTY LASTS, SO THE ABOVE LIMITATION OR EXCLUSIONS MAY NOT APPLY.

This warranty gives specific legal rights, and there may be other rights which may vary from state to state.

### IV. How To Get Warranty Service

You must provide proof of purchase (bearing the date of purchase and Product item serial number) in order to receive warranty service and, also, deliver or send the Product item, transportation and insurance prepaid, to an authorized warranty service location. Warranty service will be provided by Motorola through one of its authorized warranty service locations. If you first contact the company which sold you the Product, it can facilitate your obtaining warranty service. You can also call Motorola at 1-888-567-7347 US/Canada.

### V. What This Warranty Does Not Cover

- A. Defects or damage resulting from use of the Product in other than its normal and customary manner.
- B. Defects or damage from misuse, accident, water, or neglect.
- C. Defects or damage from improper testing, operation, maintenance, installation, alteration, modification, or adjustment.
- D. Breakage or damage to antennas unless caused directly by defects in material workmanship.
- E. A Product subjected to unauthorized Product modifications, disassemblies or repairs (including, without limitation, the addition to the Product of non-Motorola supplied equipment) which adversely affect performance of the Product or interfere with Motorola's normal warranty inspection and testing of the Product to verify any warranty claim.
- F. Product which has had the serial number removed or made illegible.
- G. Rechargeable batteries if:
  - any of the seals on the battery enclosure or cells are broken or show evidence of tampering.
  - the damage or defect is caused by charging or using the battery in equipment or service other than the Product for which it is specified.
- H. Freight costs to the repair depot.
- I. A Product which, due to illegal or unauthorized alteration of the software/firmware in the Product, does not function in accordance with MOTOROLA's published specifications or the FCC type acceptance labeling in effect for the Product at the time the Product was initially distributed from MOTOROLA.
- J. Scratches or other cosmetic damage to Product surfaces that does not affect the operation of the Product.
- K. Normal and customary wear and tear.



## VI. Patent And Software Provisions

MOTOROLA will defend, at its own expense, any suit brought against the end user purchaser to the extent that it is based on a claim that the Product or parts infringe a United States patent, and MOTOROLA will pay those costs and damages finally awarded against the end user purchaser in any such suit which are attributable to any such claim, but such defense and payments are conditioned on the following:

- A. that MOTOROLA will be notified promptly in writing by such purchaser of any notice of such claim;
- B. that MOTOROLA will have sole control of the defense of such suit and all negotiations for its settlement or compromise; and
- C. should the Product or parts become, or in MOTOROLA's opinion be likely to become, the subject of a claim of infringement of a United States patent, that such purchaser will permit MOTOROLA, at its option and expense, either to procure for such purchaser the right to continue using the Product or parts or to replace or modify the same so that it becomes noninfringing or to grant such purchaser a credit for the Product or parts as depreciated and accept its return. The depreciation will be an equal amount per year over the lifetime of the Product or parts as established by MOTOROLA.

MOTOROLA will have no liability with respect to any claim of patent infringement which is based upon the combination of the Product or parts furnished hereunder with software, apparatus or devices not furnished by MOTOROLA, nor will MOTOROLA have any liability for the use of ancillary equipment or software not furnished by MOTOROLA which is attached to or used in connection with the Product. The foregoing states the entire liability of MOTOROLA with respect to infringement of patents by the Product or any parts thereof.

Laws in the United States and other countries preserve for MOTOROLA certain exclusive rights for copyrighted MOTOROLA software such as the exclusive rights to reproduce in copies and distribute copies of such Motorola software. MOTOROLA software may be used in only the Product in which the software was originally embodied and such software in such Product may not be replaced, copied, distributed, modified in any way, or used to produce any derivative thereof. No other use including, without limitation, alteration, modification, reproduction, distribution, or reverse engineering of such MOTOROLA software or exercise of rights in such MOTOROLA software is permitted. No license is granted by implication, estoppel or otherwise under MOTOROLA patent rights or copyrights.

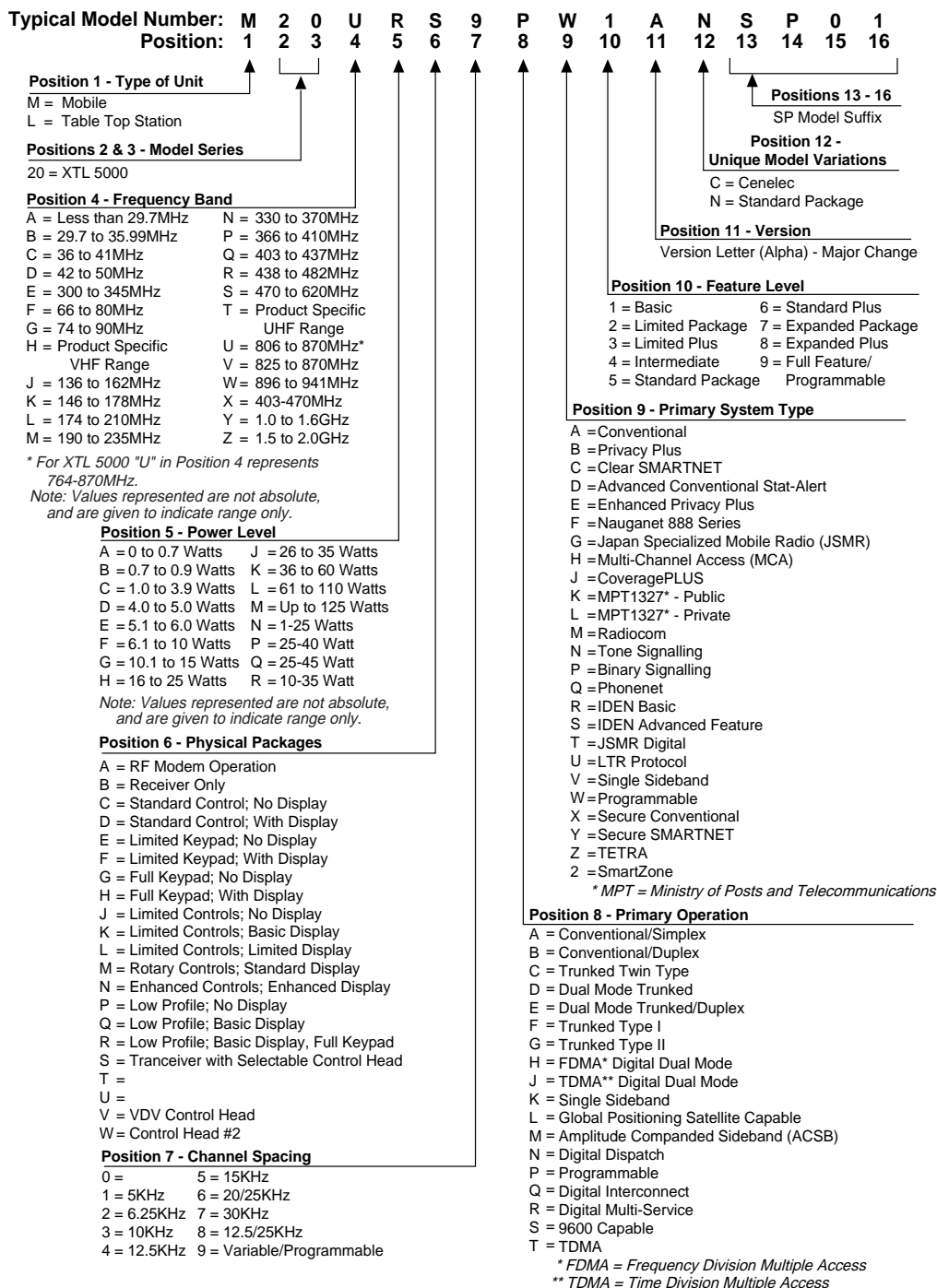
## VII. Governing Law

This Warranty is governed by the laws of the State of Illinois, USA.

## Notes

# Model Numbering, Charts, and Specifications

## Mobile Radio Model Numbering Scheme



MAEPF-27634-O

Figure 1-1. Mobile Radio Model Numbering Scheme

# ASTRO XTL 5000 Motorcycle 3.5–35 Watt Model Chart

M20URS9PW1AN 764–870 MHz										
Option									Description	
G67AD									ADD: Remote Control Microphone W4, W5, W7	
G67AF									ADD: Remote Mount No Control Head Needed	
G82AA									ADD: Motorcycle W4 Control Head	
G83AA									ADD: Motorcycle W5 Control Head	
G84AA									ADD: Motorcycle W7 Control Head	
B977DV									ADD: Control Hdw7 G48AN and G806AF	
B977EB									INT: Control Head W4 Std Button	
B977EC									INT: Control Head W5 Std Button	
B977ED									INT: Control Head W7 Std Button	
G239AR									INT: Secure Button W7	
G239AM									INT: Secure Button W4	
G239AN									INT: Secure Button W5	
G239AP									INT: Secure Button W7 G50/51	
G159AC									ADD: Encryption UCM Hardware	
G159AD									ADD: Encryption UCM HW 30-Sec Key Ret	
W22AT									ADD: Motorcycle Palm Microphone	
W15AG									ADD: Black Weather Resistant Enclosure	
G151AA									ADD: White Weather Resistant Enclosure	
B18CM									ADD: Auxiliary Speaker Spec Motorcycle	
G335AU									ADD: Ant 3 dB Motorcycle 764-870 MHz	
									Item No.	
									Description	
X	X	X							HLN6863_	Accessory Connector
X									HUF4017_	700-800 MHz Main Board
X									HHN4045_	700-800 MHz Transceiver Hardware
	X	X							HLN6861_	Hardware Standard Install
	X	X							HLN6884_	Motorcycle Interconnect Board
	X								HKN6062_	Motorcycle Control Head Cable 8'
	X	X							HLN6865_	Remote-Mount Control Head Hardware
	X	X							HLN6125_	Hardware Housing Front Remote
	X								HKN6032_	Power Cable
	X								HLN6216_	Motorcycle Hdw Spare Control Head
		X							PMLN4019_	W4 Motorcycle Control Head
			X	X					HLN6105_	Spare Button Kit
			X	X					HLN6688_	Spare Button Kit
			X						HLN6444_	W5 Motorcycle Control Head
				X					HLN6445_	W7 Motorcycle Control Head
					X				HLN6549_	W4 Standard Button Map
			X			X			HLN6548_	W5 Standard Button Map
			X			X		X	HLN6523_	W7 Standard Button Map
				X			X		HLN6524_	W7 Secure Button Map
							X		HLN6249_	W4 Secure Button Map
								X	HLN6208_	W5 Secure Button Map
								X	HLN6876_	Secure Interface Board 30-Day Key Ret
								X	HLN6877_	Secure Interface Board 30-Sec Key Ret
								X	HMN1079_	Motorcycle Palm Microphone
								X	HSN6003_	Motorcycle Water Resistant Speaker
								X	HAF4015_	Antenna 3 dB Motorcycle 764-870 MHz
								X	HAF4018_	Antenna 3 dB Low-Profile 764-870 MHz
								X	HHN6001_	White Enclosure
								X	HHN6002_	Black Enclosure
								X X	HLN6889_	Motorcycle Hardware
		X	X	X					HLN6179_	Control Head/Speaker Adapter Kit

X = Item Included  
 \_ = the latest version kit. When ordering a kit, refer to your specific kit for the suffix number.

## ASTRO XTL 5000 3.5–35 Watt Model Chart

M20URS9PW1AN 764–870 MHz												
Option										Description		
										G66AA	ADD: Dash Mount W4, W5, W7	
										G66AB	ADD: Dash Mount W3	
										G66AC	ADD: Dash Mount No Control Head Needed	
										G67AA	ADD: Remote Mount W4, W5, W7	
										G67AB	ADD: Remote Mount W9	
										G67AC	ADD: Remote Mount W3	
										G67AE	ADD: Remote Mount No Control Head	
										G72AA	ADD: W3 Handheld Control Head	
										G73AA	ADD: W4 Control Head	
										G79AA	ADD: W5 Control Head	
										G80AA	ADD: W7 Control Head	
										G81AA	ADD: W9 Control Head	
										B977DU	ADD: Control Head W9 Hdw	
										B977DV	ADD: Control Head W7 G48AN and G806AF	
										B977DZ	ADD: Control Head W9 G48AN and G806AF	
										B977EB	INT: Control Head W4 Std Button	
										B977EC	INT: Control Head W5 Std Button	
										B977ED	INT: Control Head W7 Std Button	
										G239AR	INT: Secure Button W7	
										G239AD	INT: Secure Button W9	
											<b>Item No.</b>	<b>Description</b>
X											HUF4017_	700-800 MHz Main Board
X											HHN4045_	700-800 MHz Transceiver Hardware
	X	X	X	X	X	X	X				HLN6861_	Hardware Standard Install
	X	X	X	X	X	X	X				HLN6863_	Accessory Connector
	X	X									HLN6864_	Control Head Dash Interconnect
	X	X	X								HKN4191_	Mobile Power Cable
		X		X	X	X	X				HLN6185_	Hardware Remote CH
		X		X	X	X	X				HLN6865_	Remote-Mount Control Head Hardware
		X			X						HLN6885_	Handheld CH Interconnect Board
			X	X		X					HLN6883_	Remote Interconnect Board
			X								HLN6813_	Control Head Trunnion Kit
			X								HLN6432_	Back Housing Kit
			X	X	X	X					HKN4192_	Mobile Power Cable 20 ft.
			X								HLN4921_	Trunnion
						X					HMN4044_	Handheld Control Head
						X					AAMN4045_	W4 Control Head
						X	X	X			HLN6105_	Spare Button Kit
						X	X	X			HLN6688_	Spare Button Kit
						X					HLN6440_	W5 Control Head
						X	X				HLN6396_	CH DEK Compatible
						X					HLN6441_	W7 Control Head
							X				HCN1078_	W9 Control Head (Black)
								X			HLN6481_	W9 Clear Button Kit
								X			HLN6476_	W9 Secure Button Kit
								X			HLN6549_	W4 Standard Button Map
								X			HLN6548_	W5 Standard Button Map
								X			HLN6523_	W7 Standard Button Map (Also see next page)
							X		X		HLN6524_	W7 Secure Button Map
								X		X	HLN6800_	W9 Secure Button Kit

X = Item Included

\_ = the latest version kit. When ordering a kit, refer to your specific kit for the suffix number.

ASTRO XTL 5000 3.5–35 Watt Model Chart (cont.)

M20URS9PW1AN 764–870 MHz													
Option										Description			
										G239AM		INT: Secure Button W4	
										G239AN		INT: Secure Button W5	
										G239AP		INT: Secure Button W7 G50/51	
										G239AQ		INT: Secure Button W9 G50/51	
										G159AC		ADD: Encryption UCM Hardware	
										G159AD		ADD: Encryption UCM Hdw 30 Sec Key Ret	
										W382AG		ALT: Control Station Palm Microphone	
										W665BE		ADD: Control Station Operation	
										G91AA		ADD: Control Station Power Supply	
										W22AR		ADD: W9 Palm Microphone	
										W22AS		ADD: Hand Microphone	
										W109CS		ALT: Microphone Handset with Hangup Cup	
										G110AB		INT: 17 ft Control Head Cable W4, W5, W7, W9	
										G110AC		INT: W3 Remote Y Cable	
										B18CL		ADD: Auxiliary Spkr Spectra 5 Watt	
										W432AE		ENH: 10 Watt Audio (Standard on High Power)	
										W484AD		ADD: Antenna 3 dB Gain (764-870 MHz)	
										G335AT		ADD: Antenna 1/4 Wave 764-870 MHz	
										G174AA		ADD: Antenna 3 dB Low-Profile 764-870 MHz	
										G175AA		ADD: Antenna 3 dB Elevat Feed 764-870 MHz	
										<b>Item No. Description</b>			
X												HLN6249_ W4 Secure Button Map	
	X											HLN6208_ W5 Secure Button Map	
		X										HLN6523_ W7 Standard Button Map (Also see prev. pg)	
			X									HLN6675_ W9 Secure Button Map	
				X								HMN1050_ Control Station Microphone	
					X							HLN6876_ Secure Interface Board 3 Day Key Retention	
						X						HLN6877_ Secure Interface Board 30 Sec Key Retention	
							X					HLN6042_ Base Tray	
								X				HLN6047_ BDW Installation Base Tray	
									X			HPN4001_ Control Station Power Supply	
										X		HMN1061_ W9 Palm Microphone	
											X	HMN1080_ Standard Palm Microphone W4, W5, W7	
												HLN1220_ Microphone Handset with Hangup Clip	
											X	HKN4356_ Standard 17 ft Control Head Remote Cable	
												HKN6096_ Handheld Control Head Y Cable	
												HSN4018_ Speaker 5 Watt	
												HSN6001_ Speaker 10 Watt	
											X	HAF4017_ Antenna 3 dB Gain 762-870 MHz	
												X	HAF4016_ Antenna 1/4 Wave 762-870 MHz
												X	HAF4013_ Antenna 3 dB Low Profile 762-870 MHz
												X	HAF4014_ Antenna 3 dB Elevated Feed 762-870 MHz

X = Item Included  
 \_ = the latest version kit. When ordering a kit, refer to your specific kit for the suffix number.

## 700–800 MHz Radio Specifications

GENERAL		RECEIVER	TRANSMITTER
<b>FCC Designations:</b>	AZ492FT5823	<b>Frequency Range:</b> 700 MHz Band: 764–776 MHz 800 MHz Band: 851–870 MHz	<b>Frequency Range:</b> <b>700 MHz Band:</b> Repeater Mode: 794–806 MHz Talkaround Mode: 764–776 MHz <b>800 MHz Band:</b> Repeater Mode: 806–825 MHz Talkaround Mode: 851–870 MHz
<b>Temperature Range:</b> Operating: –30° C to +60° C Storage: –40° C to +85° C		<b>Channel Spacing:</b> 12.5 kHz/20 kHz/25 kHz	
<b>Power Supply:</b> 12 Vdc Negative Ground Only		<b>Input Impedance:</b> 50 ohm	
<b>Battery Drain:</b> (Maximum) <b>35 W:</b> Standby @ 13.8 V: 0.7 A Receive at Rated Audio @ 13.8 V: 3.0 A Transmit @ Rated Power: 35 W 12.0 A		<b>Frequency Separation:</b> Full Bandsplit	<b>Rated Output Power:</b> 764–806 MHz Band: 2***/30 W 806–870 MHz Band: 35 W
<b>Dimensions (H x W x D)</b> <b>W4, W5, and W7 Models:</b> Remote-Mount Control Head: 2.0" x 7.1"x 2.2" (50.8 mm x 180.3 mm x 55.9 mm) Dash-Mount Radio: 2.0" x 7.1"x 9.1" (50.8 mm x 180.3 mm x 231.1 mm) <b>W9 Model:</b> Remote-Mount Control Head: 3.4" x 6.5"x 1.7" (86.4 mm x 165.0 mm x 43.2 mm) <b>Speaker:</b> (excluding mounting bracket) 5.5" x 5.5"x 2.5" (139.7 mm x 139.7 mm x 63.5 mm)		<b>Sensitivity:</b> <b>20 dB Quieting:</b> 25 kHz Channel Spacing: 0.30 µV <b>12 dB SINAD:</b> 25 kHz Channel Spacing: 0.25 µV	<b>Channel Spacing:</b> 12.5 kHz/20 kHz/25 kHz
		<b>Digital Sensitivity**:</b> 1% BER (12.5 kHz channel): 0.30 µV 5% BER (12.5 kHz channel): 0.25 µV	<b>Output Impedance:</b> 50 ohm
		<b>Adjacent Channel Selectivity*:</b> 25 kHz Channel: 80 dB 12.5 kHz Channel: 65 dB	<b>Frequency Separation:</b> Full Bandsplit
		<b>Intermodulation*:</b> 80 dB	<b>Frequency Stability*:</b> (–30° to +60°C; 25°C Ref.): ±0.00015%
<b>Weight:</b> Radio: 6.1 lbs (2.8 kg) Speaker: 1.5 lbs (0.7 kg)		<b>Spurious Rejection*:</b> 90 dB	<b>Modulation Limiting*:</b> 25 kHz Channel Spacing: ±5.0 kHz 12.5 kHz Channel Spacing: ±2.5 kHz
		<b>Frequency Stability*:</b> (–30° to +60° C; 25° C Ref.): ±0.00015%	<b>Modulation Fidelity (C4FM)**:</b> 12.5 kHz Digital Channel: ±2.8 kHz
		<b>Audio Output at 3% Distortion*:</b> 7.5 Watts into 8 Ohms 13 Watts into 3.2 Ohms	<b>FM Hum and Noise*:</b> 20/25 kHz Channel: –40 dB 12.5 kHz Channel: –34 dB
			<b>Emission (Conducted and Radiated):</b> –70 dBc/–85 dBc (GNSS)
			<b>Audio Sensitivity*:</b> (For 60% Max. Deviation at 1 kHz): 0.08 V ±3 dB
			<b>Audio Response*:</b> (6 dB/Octave Pre-Emphasis 300 to 3000 Hz): +1,–3 dB
			<b>Audio Distortion*:</b> 2%
			<b>Emissions Designators:</b> 8K10F1D, 8K10F1E, 11K0F3E, 16K0F3E, and 20K0F1E

Specifications subject to change without notice.

\* Measured in analog mode per TIA/EIA 603 under nominal conditions.

\*\* Measured in digital mode per TIA/EIA IS 102.CAAB.

\*\*\* 2 W. itinerant frequencies.

## Notes



---

# Chapter 1 Introduction

## 1.1 Notations Used in This Manual

Throughout the text in this publication, you will notice the use of note, caution, warning, and danger notations. These notations are used to emphasize that safety hazards exist, and due care must be taken and observed.

**NOTE:** An operational procedure, practice, or condition that is essential to emphasize.



Caution

CAUTION indicates a potentially hazardous situation which, if not avoided, might result in equipment damage.



WARNING

WARNING indicates a potentially hazardous situation which, if not avoided, could result in death or injury.



DANGER

DANGER indicates an imminently hazardous situation which, if not avoided, will result in death or injury.

## 1.2 Radio Description

The ASTRO XTL 5000 digital mobile radio is Motorola's newest two-way mobile radio designed for your organization's most demanding needs. The XTL 5000 Mobile is available in the 764–870 MHz frequency band with 3.5–35 W variable power (2 W itinerant).

The ASTRO XTL 5000 radios are among the most sophisticated two-way radios available. They have a new robust design for radio users who need high performance, quality, and reliability in their daily communications. This new architecture provides the capability of supporting a multitude of legacy and advanced features resulting in a more cost-effective two-way radio communications solution.

---

The ASTRO XTL 5000 radios are available with five control heads. [Table 1-1](#) provides a description of basic features for these control heads.

*Table 1-1. Control Head Basic Features*

Feature	W3	W4	W5	W7	W9
Display	2 line/14 characters Liquid-Crystal Display (LCD) with 8 Status Annunciators	1 line/8 characters Vacuum Fluorescent Display	1 line/8 characters Vacuum Fluorescent Display	1 line/8 characters Vacuum Fluorescent Display	1 line/11 characters Vacuum Fluorescent Display
Control Type	Rocker Switches	Rotary Mode and Volume Controls	Rocker Switch Mode and Volume Controls	Rocker Switch Mode and Volume Controls	Rocker Switch Mode and Volume Controls
Numeric Keypad	Yes	No	No	Yes	Yes
Channel Capability	512	512	512	512	512
Remote Mount	Available	Available	Available	Available	Available
Dash Mount	Available	Available	Available	Available	Not Available
Dual Control Head	Not Available	Available	Available	Available	Available
Motorcycle	Not Available	Available	Available	Available	Not Available

### 1.3 FLASHport®

All ASTRO XTL 5000 digital mobile radios are part of the FLASHport program and ship standard with a FLASH EE Prom, which allows for feature and system upgrades. FLASHPort Aftermarket Software is used to upgrade to the latest version of your System Enhancement Software Package, to upgrade to a different System Enhancement Software Package, or to order enhancements for existing ASTRO XTL 5000 digital radios in the field.

### 1.4 Control Head Descriptions

The control heads used with XTL 5000 radios have microprocessor circuitry that operates the standard and optional features built into the system.

The following illustrations show some typical ASTRO XTL 5000 control heads.

### 1.4.1 W3 Control Head

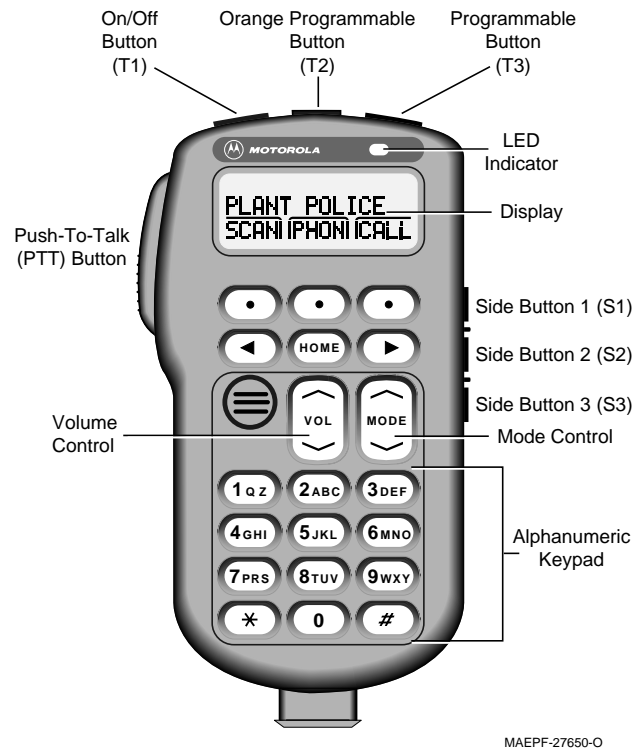
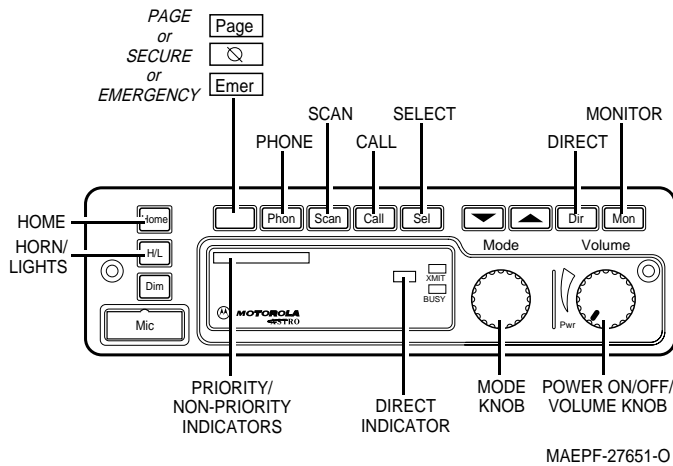


Figure 1-1. W3 Hand-Held Control Head

### 1.4.2 W3 Controls

- On/Off Button (T1) — Turns the radio on and off.
- Orange Programmable Button (T2) — Programmed at the factory for emergency. Field-programmable by a qualified radio technician.
- Programmable Button (T3) — Field-programmable by a qualified radio technician.
- LED Indicator — Green/red light-emitting diode indicates operating status.
- Display — Two-line x 14-character display provides visual information about many radio features.
- Keypad — Provides control of, and data interface with, many features.
- Programmable Side Button 1 (S1) — Field-programmable by a qualified radio technician.
- Programmable Side Button 2 (S2) — Field-programmable by a qualified radio technician.
- Programmable Side Button 3 (S3) — Field-programmable by a qualified radio technician.
- Mode Control — Is used for selecting modes and programming menus.
- Volume Control — Is used for selecting the volume level, editing names, and making certain radio adjustments.
- Push-To-Talk (PTT) Button — Engages the transmitter.

### 1.4.3 W4, W5, W7, and W9 Controls Heads



**NOTE:** *Typical* as stated in the figure titles refers to the ability to customize the features accessed by certain pushbuttons on the control heads.

Figure 1-2. Typical W4 Rotary Control Head

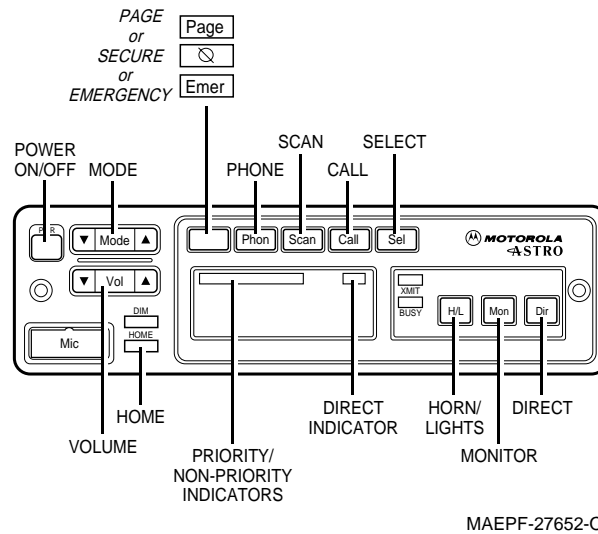


Figure 1-3. Typical W5 Limited Keypad Control Head

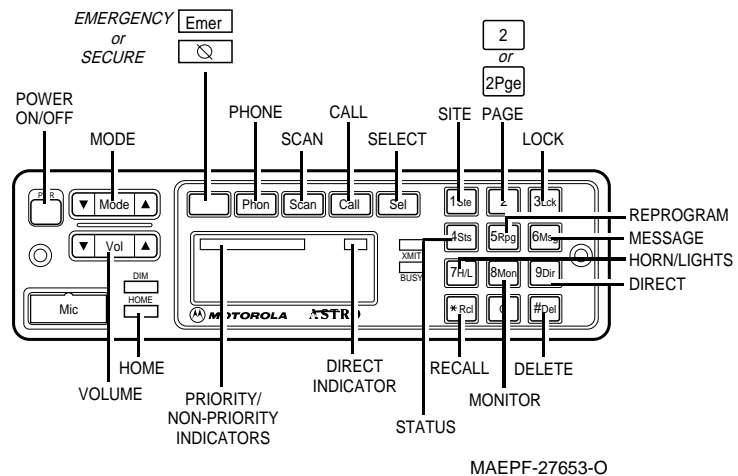
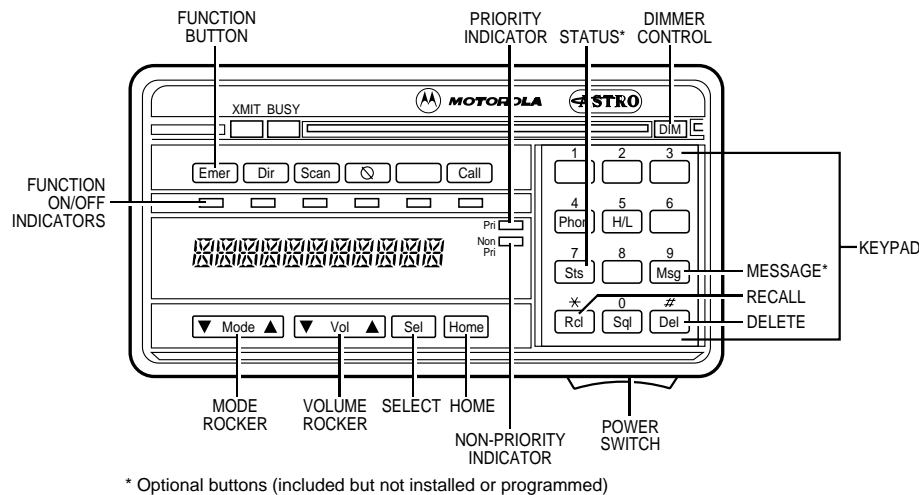


Figure 1-4. Typical W7 Full Keypad Control Head



MAEPF-27654-O

Figure 1-5. Typical W9 Full Keypad Control Head

#### 1.4.4 W4, W5, W7, and W9 Controls

- **Power Switch** — The power (PWR) switch turns the radio and its accessories on or off. The power switch is part of the rotary volume knob on the W4 model, a push-type switch on the W5 and W7 models, and a slide switch on the right-hand bottom surface of the W9 model.
- **Mode Switch** — The Mode switch is used for selecting modes and programming menus. The Mode switch is a rotary switch on the W4 model and a rocker switch on the W5, W7, and W9 models. Pressing the right side of this rocker switch increases the mode number. Pressing the left side decreases the mode number. If you press and hold the switch, it scrolls the mode number up or down. The mode names appear in the display window.
- **Volume Switch** — The Volume switch is used for selecting the volume level, editing names, and making certain radio adjustments. The Volume switch is a rotary switch on the W4 model and a rocker switch on the W5, W7, and W9 models. On the pushbutton models, pressing and releasing the volume switch checks the volume setting. Your display will show "VOLUME \_ \_" and a number value (0-15). Press and hold the left side to decrease the volume. The number value scrolls up or down to your desired level. The Volume rocker switch also controls the volume level of the public address (PA) and external radio speaker (Ex Rd) options when they are enabled. The display window shows "PA VOL \_ \_" when public address is on and the Volume rocker switch is pressed.
- **Dim Button** — The DIM button is used to control the brightness of the display and button backlighting. When you turn on the system, the display comes on at the brightness level it was on before the system was last turned off. Press the DIM button once to reduce the brightness of the display to medium level and twice for low brightness level. Press the DIM button a third time to turn the display and button backlighting off. This is called the "surveillance" mode.
- **Home Button** — The Home button is used for restoring preprogrammed mode, establishing programmed mode, selecting programming entries, etc. Press the Home button to go to the radio's preprogrammed "home" mode. On the W7 models, you may use the Home button instead of Mode switch to change modes. Hold the Home button until a beep sounds to enter the configuration state. The display shows an entry prompt. Use the keypad to enter your new mode choice and press the Home button again. Your mode is now changed without scrolling.
- **Select Button** — The Sel button is used to configure radio options.
- **Option Buttons** — The option buttons are used for turning options on and off, such as Phone, Scan, Emergency Call, and Secure.

- Display — The vacuum fluorescent (VF) display's primary function is to display mode numbers, mode names, volume level, and the status of options. It also functions as an on-off indicator for the entire system and plays an integral role in the operator's reconfiguration of options. The display is 8 characters on W4, W5, and W7 models; 11 characters on the W9 model.
- XMIT and BUSY Indicators — The XMIT indicator lights when the radio is transmitting. The BUSY indicator lights when the selected channel is busy.
- Scan Indicators — When scan operation detects activity on a non-priority (NON-PRI) channel, the NON-PRI indicator light comes on. Activity on a second priority channel causes the priority (PRI) indicator to light. First priority channel activity causes PRI to flash.
- 12-Button Keypad (W7 and W9) — The keypad is used to change the status of options and for entering numbers. Several keys serve multiple functions. See the ASTRO XTL 5000 Digital User's Guide for a complete description of keypad operation.
  - Site (**Ste** - #1 key) — Forces the radio to scan for a new site when the automatic multiple-site select (AMSS) feature for wide-area coverage is in use.
  - Page (**2** or **2Pge** - #2 Key) — Initiates a Call Alert page/enters Call ID list programming.
  - Lock (**Lck** - #3 key) — Locks the radio onto the current site when the AMSS feature is in use.
  - Status (**Sts** - #4 key) — Used alone or in conjunction with other keypad buttons and the **Sel** button to send a status transmission, indicating a predetermined condition change.
  - Regroup (**Rpg** - #5 key) — Requests a change in the radio's talkgroup assignment when the dynamic regrouping feature is used.
  - Message (**Msg** - #6 key) — Used alone or in conjunction with other keypad buttons and the **Sel** button to transmit a message, indicating a response or temporary condition.
  - Horn/Lights (**H/L** - #7 key) — Selects/enables radio external alarms.
  - Monitor (**Mon** - #8 key) — Monitors the radio for channel traffic.
  - Direct/Simplex (**Dir** - #9 key) — Used for talkaround (mobile-to-mobile) conversations.
  - Recall (**Rcl** - \* key) — Reviews modes in scan and phone lists.
  - Delete (**Del** - # key) — Used when editing stored lists.

---

# Chapter 2 Basic Maintenance

## 2.1 Introduction

This section of the manual describes preventive maintenance, handling precautions, and some basic repair procedures and techniques. Each of these topics provides information vital to the successful operation and maintenance of your radio.

**NOTE:** For board- and component-level repair of the radio, refer to the *Detailed Service Manual* (see ["Related Publications" on page xii](#)).

## 2.2 Preventive Maintenance

Radios are shipped from the factory with a worst-case frequency error of  $\pm 500$  Hz for 700–800 MHz. These specifications are tighter than the more stringent FCC requirements of  $\pm 1.5$  ppm for the 700–800 MHz bands. For radios that have been in storage for over six months from the factory ship date, the reference oscillator should be checked when the radio is initially deployed to the field. It is strongly recommended that the reference oscillator be checked every time the radio is serviced or at least once a year, whichever comes first. The crystal contained in the reference oscillator naturally drifts over time due to its aging characteristic. Periodic (annual) adjustment of the reference oscillator is important for proper radio operation. Improper adjustment can result in both poor performance and interference with other users operating on adjacent channels.


### 2.2.1 Inspection

Check that the external surfaces of the radio are clean, and that all external controls and switches are functional. A detailed inspection of the interior electronic circuitry is not needed.

### 2.2.2 Cleaning

The following procedures describe the recommended cleaning agents and the methods to be used when cleaning the external and internal surfaces of the radio. External surfaces include the control head and radio chassis. These surfaces should be cleaned whenever a periodic visual inspection reveals the presence of smudges, grease, and/or grime. Internal surfaces should be cleaned only when the radio is disassembled for servicing or repair.

The only recommended agent for cleaning the external radio surfaces is a 0.5% solution of a mild dishwashing detergent in water. The only factory recommended liquid for cleaning the printed circuit boards and their components is isopropyl alcohol (70% by volume).

 <b>Caution</b>	The effects of certain chemicals and their vapors can have harmful results on certain plastics. Aerosol sprays, tuner cleaners, and other chemicals should be avoided.
---	--

#### 2.2.2.1 Cleaning External Plastic Surfaces

The detergent-water solution should be applied sparingly with a stiff, non-metallic, short-bristled brush to work all loose dirt away from the radio. A soft, absorbent, lint-free cloth or tissue should be used to remove the solution and dry the radio. Make sure that no water remains entrapped near the connectors, cracks, or crevices.

---

### 2.2.2.2 Cleaning Internal Circuit Boards and Components

Isopropyl alcohol may be applied with a stiff, non-metallic, short-bristled brush to dislodge embedded or caked materials located in hard-to-reach areas. The brush stroke should direct the dislodged material out and away from the inside of the radio. Be careful not to break off electrical components.

Alcohol is a high-wetting liquid and can carry contamination into unwanted places if an excessive quantity is used. Make sure that controls or tunable components are not soaked with the liquid. Do not use high-pressure air to hasten the drying process, since this could cause the liquid to puddle and collect in unwanted places.

Upon completion of the cleaning process, use a soft, absorbent, lint-free cloth to dry the area. Do not brush or apply any isopropyl alcohol to any plastic parts.

**NOTE:** Always use a fresh supply of alcohol and a clean container to prevent contamination by dissolved material (from previous usage).

### 2.2.3 General Radio Care and Handling Precautions

- Avoid physical abuse: do not pound, drop, or throw the radio. It may damage exposed parts such as controls and connectors.
- Do not connect accessories other than Motorola compatible equipment as they may damage the radio.
- The use of any mini-UHF adaptor not listed in this manual can damage the RF antenna connector and lead to radio failure and may void the warranty.
- Operating the radio without an antenna cable attached may lead to radio failure and may void the warranty.

### 2.2.4 RF Power Amplifier (RF PA) Heatsinking

You should never transmit unless the printed-circuit board (PCB) DC/RF clips and internal screws are installed in the chassis. Doing so can result in immediate failure of RF PA devices or greatly reduced RF PA device life. You also can transmit for short periods with the chassis eliminator if it is used properly.

## 2.3 Handling Precautions

Complementary metal-oxide semiconductor (CMOS) devices, and other high-technology devices, are used in this family of radios. While the attributes of these devices are many, their characteristics make them susceptible to damage by electrostatic discharge (ESD) or high-voltage charges. Damage can be latent, resulting in failures occurring weeks or months later. Therefore, special precautions must be taken to prevent device damage during disassembly, troubleshooting, and repair. Handling precautions are mandatory for this radio, and are especially important in low-humidity conditions. DO NOT attempt to disassemble the radio without observing the following handling precautions:

- Eliminate static generators (plastics, Styrofoam, etc.) in the work area.
- Remove nylon or double-knit polyester jackets, roll up long sleeves, and remove or tie back loose-hanging neckties.
- Store and transport all static-sensitive devices in ESD-protective containers.
- Disconnect all power from the unit before ESD-sensitive components are removed or inserted unless otherwise noted.
- Use a static-safeguarded workstation, through the use of an anti-static kit (Motorola part number 01-80386A82). This kit includes a wrist strap, two ground cords, a static-control table mat and a static-control floor mat.



---

**NOTE:** Be sure that the table and floor mats are properly grounded.

When these items are not readily available, observing the following techniques will minimize the chance of damage:

- If a static-sensitive device is to be temporarily set down, use a conductive surface for placement of the device.
- Make skin contact with a conductive work surface first and maintain this contact when the device is set down or picked up.
- Always wear a conductive wrist strap when servicing this equipment. The Motorola part number for a replacement wrist strap that connects to the table mat is 42-80385A59.
- For additional information, refer to *Service and Repair Note SRN-F1052, Static Control Equipment for Servicing ESD Sensitive Products*, available from the Literature Distribution Center.

Motorola  
Literature Distribution Center  
2200 Galvin Drive, Suite 2218  
Elgin, IL 60123  
(847) 783-2522  
(847) 783-2523/2524 (Fax)

## Notes

---

## Chapter 3 Basic Theory of Operation

### 3.1 Introduction

The ASTRO XTL 5000 radio combines the controller and RF sections into a single board and contains three modules: a daughtercard, RX VCO module, and TX VCO module. It is important to correctly identify the malfunctioning region before replacing expensive modules. To assist with radio repair, descriptions of the sections contained on the XTL 5000 uniboard are listed below.

### 3.2 General Overview

The XTL 5000 radios are wideband, synthesized, fixed-tuned radios and are available with 700 and 800 MHz bands. All XTL 5000 radios are capable of both analog operation (12.5 kHz, 20 kHz, and 25 kHz bandwidths) and ASTRO mode operation (12.5 kHz bandwidth).

The XTL 5000 radios contain the following assemblies and sections:

- Control-Head Assembly (Dash- or Remote-Mount)—is connected directly to the front of the transceiver or remotely by the interconnect board and control cable. This assembly contains a vacuum fluorescent (VF) display, VF driver, microprocessor and serial bus interface.
- Power Amplifier (PA) section—contains the antenna switch, directional coupler/ detector, and amplifier(s).
- Front-End Receiver section—contains the preselector, low-noise amplifier (LNA), and mixer.
- IF section—contains the receiver intermediate-frequency (IF) amplifier/filter and the digital receiver back-end integrated circuit (IC).
- Frequency Generation section—contains the synthesizer, voltage controlled oscillators (VCOs), reference oscillator, and receive and transmit buffers.
- Controller section—combines a VOCON board and a Command board, into a single section, and contains the following elements:
  - Voltage regulators, data communication circuitry (RS232, USB, and SB9600)
  - Daughtercard module (Microprocessor, FLASH IC, SRAM IC)
  - Modulation D/A conversion circuitry
  - CODEC audio circuitry
  - TX power-control circuitry
  - Emergency circuitry
  - V.I.P input/output paths
  - Secure interconnect board interface
  - Front connector interface for control heads and remote-mount interconnect boards (I.B)
  - Rear connector for additional accessories
  - DC power-in plug

## 3.3 Controller Section

### 3.3.1 Introduction

The XTL 5000 radio is primarily a uniboard design, consisting of isolated topside and bottomside controller sections and various RF sections. The controller section will be discussed here in basic terms, to assist in the overall understanding of what is contained in the controller section, and a simplified purpose of its elemental parts. Some limited warnings and recommendations are offered for prevention of common repair-induced damage.

The controller section combines the elements of a VOCON board, with the elements of a command board. The controller section also contains a daughtercard module. We distinguish the entire controller section into 2 parts: the "daughtercard module" and the "surrounding controller region".

### 3.3.2 Location

The controller section is located on the far side of the board, with critical parts arranged on the top and bottom sides of the uniboard. (see [Figure 3-1](#) below, with component-filled areas denoting controller section).

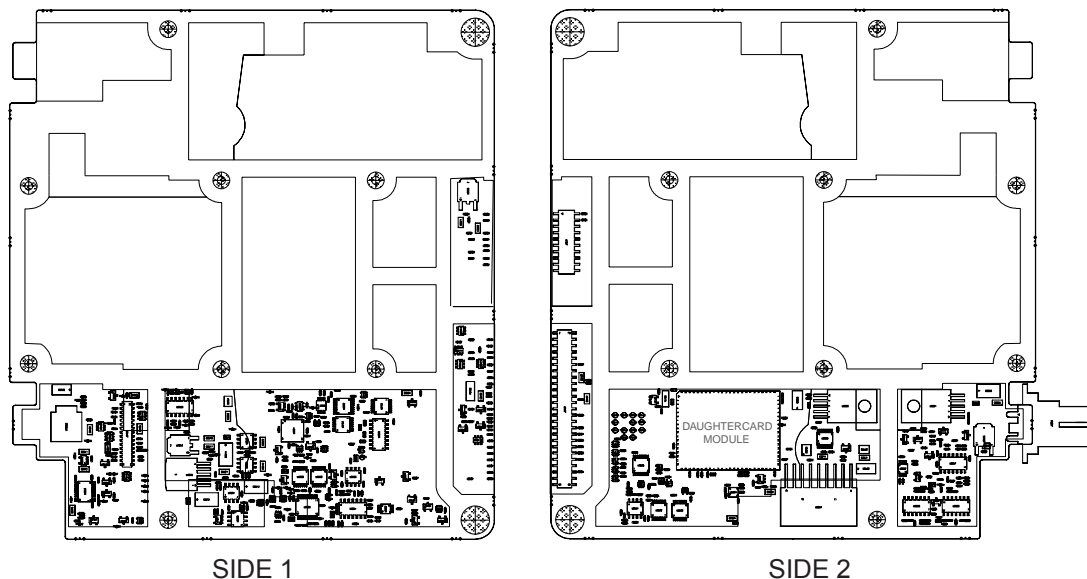


Figure 3-1. Controller Sections



Caution

Troubleshooting of the controller section usually requires the removal of the uniboard from the chassis. Whenever this board is removed, any transmitting of the RF section, whether intentional or accidental (trunking affiliation), can cause permanent destruction or degradation of various RF components. Such damage may not be visually noticeable, but can impact the radios performance and reliability.

## 3.4 Daughtercard Module

This module contains primarily three parts: microprocessor, FLASH IC, and SRAM IC.

**NOTE:** The three parts on the daughtercard module are highly susceptible to ESD and moisture damage. Extreme care is advised.

### 3.4.1 Microprocessor

The microprocessor consists of an MCORE-based controller and a DSP that communicates with the memory ICs via a 16-bit data bus. It also communicates to peripheral ICs on the main board via an SSI and SPI bus. This microprocessor contains a fixed amount of one-time programmable ROM and a small section of RAM. However, the microprocessor does not contain the radio software setting as programmed in the Customer Programming Software (CPS) or the firmware as installed at the factory. The only purpose of this IC is for interpretation and processing of the content inside the FLASH IC. Therefore, this part may be replaced as is without the need to reflash the radio.

There are six clocks supplied to the daughtercard, a 16.8 MHz master clock (CKIH), a 32 kHz real-time clock (CKIL), a 20 kHz RX frame-sync clock, a 48 kHz TX frame-sync clock, a 1.2 MHz RX data clock, and a 2.4 MHz TX data clock. The microprocessor also generates the digital audio bus clocks: a 512 kHz data clock and an 8 kHz frame-sync clock.

### 3.4.2 FLASH IC

The FLASH IC is the firmware storage IC. Programming this IC is accomplished using one of three input paths:

- 2-wire RS232 directly from a computer's serial port to the radio's rear connector data cable, HKN6160
- 2-wire RS232 through an HKN6155 programming cable at the control head's 10-pin microphone port
- 2-wire RS232 through an HKN6155 programming cable at the Remote Mount Interconnect board's 10-pin flash port.



Caution

if you choose to reflash the radio (reflash the IC), DO NOT interrupt the process; otherwise, you might corrupt the FLASH IC and need advanced technical support to revive your radio.

**NOTE:** In remote-mount configurations, the control head 10-pin microphone port is disabled for any kind of programming.

**NOTE:** It is recommended that FLASH IC replacement is not supported as a field repair option. If this part is removed, the radio must be reflashed and retuned. This is because the FLASH IC must be hard-boot loaded at the factory to allow the programming of a unique file.

### 3.4.3 SRAM IC

The SRAM IC is only used by the microprocessor to perform its memory operations and is not upgradeable to a larger SRAM IC.

## 3.5 Surrounding Controller Region

### 3.5.1 Introduction

The surrounding controller region contains the regulated power, audio, and data translation hardware.

This hardware allows a computer to program the radio's features, maintain an active control of the RF sections, and make necessary mode and audio adjustments as related to feedback from a control head device.

**NOTE:** A control head is not necessary for the function of the radio (in special application configurations), but the controller section is critical for the RF sections to function. This is an important point since repairs and troubleshooting of the RF sections usually requires that the controller section is operating correctly.

### 3.5.2 Voltage Regulation

The uniboard contains the following voltage regulators: 9 V, 5 V, 3 V, 2.85 V, 1.85 V, and 1.55 V.

The radio's A+ supply is regulated down to additional supplies for various blocks (frequency generation unit (FGU), receiver, transmitter power amplifier, and controller). Specifically, A+ is used to regulate three separate 9.3-volt supplies, one for the FGU and receiver circuitry, one for the transmitter power amplifier circuitry, and one for the controller sections.

- The FGU and receiver circuitry use the 9.3-volt supply to further regulate a common 5-volt supply and two separate 3-volt supplies, one for the FGU and one for the Abacus III IC.
- The transmitter power amplifier uses its 9.3-volt supply directly for its pre-amplifier and to a 3-volt supply for most of the ALC (automatic level control).
- The controller uses the 9.3-volt supply to power the microphone, part of a RS232 translator, and to provide voltage to the 5-volt regulator, which supplies the 2.85 V, 1.85 V, and 1.55 V supplies.
  - The 2.85-volt regulator supplies most of the digital logic circuitry on the controller, as well as the I/O of the microprocessor.
  - The 1.85-volt regulator supplies the FLASH and SRAM circuitry.
  - The 1.55-volt regulator supplies the core of the microprocessor.

### 3.5.3 Emergency

Circuitry exists to support emergency switch operation. While the radio is ON, emergency can be activated to alert dispatch.

**NOTE:** This feature is either visual or can be set to covert, and is programmable through the CPS (customer programming software). This functionality is dependent on CPS version and customer demand for feature availability.

### 3.5.4 Front and Rear Connectors

The surrounding controller section contains the front and rear connections to allow interfacing with existing and future accessories.

These custom connectors are optimized to meet voltage and current requirements for existing accessories and for the compatible flexes that are used with the XTL 5000 radio.

**NOTE:** It is not recommended to insert non-Motorola parts or flexes into these connectors.

### 3.5.4.1 Audio

The audio circuitry of the controller section contains the following:

- Audio PA
- Codec
- MIC Audio
- DSP controlled EEPOTS
- AUX RX, AUX TX, and external speaker paths
- FILT audio.

This allows interfacing to the existing accessories made by Motorola, such as VRS, SIREN, and Consolette. It also allows for select compatibility with aftermarket modems.

### 3.5.4.2 Program Cable

If the programming cable is used with a standard legacy control head, circuitry found in the controller section provides the voltage-translated boot RX and boot TX communication paths, as well as the cable-detection circuit.

### 3.5.4.3 SB9600

Just as on many Motorola products, an SB9600 communication bus exists on the XTL 5000 radio. Hence, many Motorola SB9600 accessories are compatible with the radio. These lines include BUS+, BUS-, Busy, and RESET. These lines are available at connectors J5 and J6.

### 3.5.4.4 VIP

VIP-IN and VIP-OUT lines are available at the front and two VIP-out lines are located at the rear. Their purpose is to drive relays to control external logical devices, or to logically communicate directly to the XTL 5000 microprocessor. Their most versatile usage is in conjunction with a DEK, but this is not mandatory.

**NOTE:** Please see the VIP section of the ASTRO XTL 5000 700–800 MHz Digital Portable Radio Detailed Service Manual for configurations and voltage level requirements.

### 3.5.4.5 RS232

UART\_A can be selected as a standard 4-wire RS232 or 4-wire USB slave device. The UART\_B is defaulted to use SB9600 lines so that all legacy control heads and SB9600 accessories are compatible with the radio.

### 3.5.4.6 One-Wire

One-wire technology is embedded in the radio for future compatibility with upcoming smart accessories.

## 3.6 Analog Mode of Operation

### 3.6.1 Receive Operation

When the radio is receiving, the signal comes from the antenna through the RF PA output network located in the power amplifier section to the front-end receiver assembly. The signal is then filtered, amplified, and mixed with the first local oscillator signal generated by the receiver voltage controlled oscillator (VCO). The resulting intermediate-frequency (IF) signal is fed to the IF circuitry where it is again filtered and amplified. This amplified signal is passed to the Abacus III IC where it is mixed with the second local oscillator to create the second IF at 2.25 MHz. The analog IF is processed by an analog-to-digital (A/D) converter located within the digital back-end IC, where it is converted to a digital bit stream and decimated down to an I/Q digital sample. This digital signal is then passed on to the DSP, where filtering and discrimination are performed in the software. For a voice signal, the DSP routes the digital voice data to the Codec for conversion to an analog signal. The signal passes through a Log Pot to the audio power amplifier, which drives the speaker. For signaling information, the DSP decodes the message and passes it to the microcomputer.

### 3.6.2 Transmit Operation

When the radio is transmitting, microphone audio is passed to the gain control, and then to the Codec, where the signal is digitized. The Codec passes digital data to the DSP, where pre-emphasis and low-pass (splatter) filtering is done. The DSP returns this signal to the Codec and the signal is then passed to a digital-to-analog (DAC) converter where it is reconverted into an analog signal. The signal is then passed through a switched capacitor filter IC and then to the synthesizer IC as a modulation signal for the transmitter voltage controlled oscillators. Also, transmitted signaling information is accepted by the DSP from the microcomputer, coded appropriately, and passed to the Codec, which handles it the same as a voice signal. Modulation information is passed to the synthesizer along the modulation line. A modulated carrier is provided to the RF power amplifier, which transmits the signal under dynamic power control.

## 3.7 ASTRO Mode of Operation

In the ASTRO mode (digital mode) of operation, the transmitted or received signal is limited to a discrete set of deviation levels, instead of continuously varying. The receiver handles an ASTRO-mode signal identically to an analog-mode signal up to the point where the DSP decodes the received data.

In the ASTRO receive mode, the DSP uses a specifically defined algorithm to recover information.

In the ASTRO transmit mode, microphone audio is processed the same as an analog mode with the exception of the algorithm the DSP uses to encode the information. This algorithm will result in deviation levels that are limited to discrete levels.

## 3.8 Control Head Assembly

### 3.8.1 Display (W4, W5, and W7 Control Heads)

The W4, W5, and W7 control-head assemblies have an 8-character, alphanumeric, vacuum fluorescent display. The anodes and the grids operate at approximately 34 Vdc when on and 0 Vdc when off. The filament operates at approximately 24 Vrms. The voltage for the display is generated by a fixed-frequency, variable duty-cycle controlled “flyback” voltage converter. The switching frequency is approximately 210 kHz. The internal microprocessor controls the voltage converter, which provides approximately 3.7 Vdc to the vacuum fluorescent (VF) driver and approximately 2.4 Vrms to the VF display.



### 3.8.2 Display (W9 Control Head)

The W9 control-head assembly has an 11-character, alphanumeric, vacuum fluorescent display. It needs three separate voltages to operate: the cathode needs 35 V to accelerate electrons to the anode; the grid needs 40 V to totally shut off current flow; the filament needs 3.8 Vrms at 80 mA. These voltages are obtained from the transformer on the display controller board.

### 3.8.3 Vacuum Fluorescent (VF) Display Driver

This VF display driver receives ASCII data from the controller section of the main board, decodes it into display data, and then scans the display with the data. Once properly loaded into the display, data is refreshed without any further processor action. The display driver is periodically reset by the actions of transistors that watch the clock line from the microprocessor to the display driver. When the clock line is held low for more than 600 ms, the display driver resets and new display data follows.

### 3.8.4 Vacuum Fluorescent (VF) Voltage Source (W9)

Voltage for the VF display is generated by a fixed frequency, variable-duty cycle-driven, flyback voltage converter. An emitter-coupled astable multivibrator runs at approximately 150 kHz. The square-wave output from this circuit is integrated to form a triangle that is applied to the non-inverting input of half an IC.

During start up, the inverting input is biased at 3.7 V. A transistor is on while the non-inverting input voltage is below 3.7 V. This allows current to flow in a transformer, building a magnetic field. When the triangle wave exceeds 3.7 V, the transistor turns off and the magnetic field collapses, inducing negative current in the transformer.

This current flow charges two capacitors. As the voltage on one of the capacitors increases beyond 35 V, a diode begins to conduct, pulling the integrated circuit's inverting input below 3.7 V. This decreases the cycle time to produce the 35 V. The 41-volt supply is not regulated, but it tracks the 35-volt supply.

Similarly, the AC supply for VF filament is not regulated, but is controlled to within one volt by an inductor on the display board.

### 3.8.5 Controls and Indicators

The control head assembly processes all the keypad (button) inputs and visual indicators through the microprocessor. Some of the buttons double as function keys for radio options. All buttons are backlit to allow operation in low light. Refer to [Chapter 1. Introduction](#) ("1.4 Control Head Descriptions" on page 1-2) for functional descriptions of each control switch, button, or indicator.

### 3.8.6 Status LEDs

These LEDs are driven by the display driver as though they were decimal points on the VF display. Level shifting transistors are required for this since the display driver uses 39 Vdc for control signals.

### 3.8.7 Backlight LEDs

The microprocessor operates the backlight LEDs. A transistor supplies base current to the individual LED driver transistors. The driver transistors act as constant current sources to the LEDs. Some backlight LEDs are connected to a thermistor. This circuit allows more current to flow through these LEDs at room temperature and reduces current as the temperature rises.

## 3.8.8 Vehicle Interface Port (VIP)

### 3.8.8.1 Remote-Mount

The VIPs allow the control head to operate outside circuits and to receive inputs from outside the control head. There are three VIP outputs that are used for the W9 control head and two VIP outputs for the W3, W4, W%, and W7 control heads. There are also three VIP inputs that accept inputs from switches. See the cable kit section for typical connections of VIP input switches and VIP output relays.

The VIP output pins are located on the back of the control head below the area labeled "VIP." These connections are used to control relays. One end of the relay should be connected to switched B+, while the other side is connected to a software-controlled on/off switch inside the control head. The relay can be normally on or normally off depending on how the VIP outputs are configured. The function of these VIP outputs can be defined by field programming the radio. Typical applications for VIP outputs are external horn/lights alarm and horn ring transfer relay control.

### 3.8.8.2 Dash-Mount

The VIP outputs are driven by a serial-to-parallel shift register. The output transistors are capable of sourcing 300mA current. Primarily, these transistors control external relays. The relay is connected between the collector and switched B+.

Each VIP input transistor is connected to a dedicated input port through transistors used for input protection. These VIP inputs are connected to ground with either normally open or normally closed switches.

## 3.8.9 Control-Head Power Supplies

This section describes the control-head power supply operation.

### 3.8.9.1 W3 Control Head

W3 control heads supply power to the switched B (SWB+) line through a P-channel power MOSFET from the HLN6885 interface board only.

### 3.8.9.2 W4 Control Head

For W4 control heads, power to SWB+ is supplied by a mechanical switch on the volume control knob. If the ignition line option is used, power to the switch comes directly from the ignition wire instead of A+.

### 3.8.9.3 W5, W7, W9 Control Heads

SWB+ is supplied from A+ through an N-channel power MOSFET driven by the Serial Input/Output (SIO) IC in the legacy control heads. SWB+ supplies power to the accessories, the VF display, the 5-volt regulator, and the power-control line for the main board for all other voltage regulators on the main board. The SIO IC monitors the condition of the power switch and the ignition switch to determine the on/off state of the radio.

## 3.8.10 Ignition Sense Circuits

A transistor senses the vehicle ignition's state, disabling the radio when the ignition is off. For negative-ground systems, the orange lead for remote-mount radios and the red lead for dash-mount radios is typically connected to the fuse box (+12 V).

## 3.9 Radio-Frequency Power Amplifier (RF PA) and Output Network (ON)

The RF PA is a three-stage power amplifier consisting of discrete LDMOS transistors:

- Controlled stage
- Driver stage
- Final stage

The RF PA is followed by the ON section consisting of discrete circuitry with the following functions:

- Antenna switch
- Harmonic Filter
- Power Detector

### 3.9.1 Gain Stages

The controlled stage consists of a two-stage, integrated amplifier with external matching which amplifies the input signal from the VCO buffer and provides drive to the driver stage. Power is controlled via gate bias to both internal stages and drain bias is supplied via K9.1V. The drive stage has a fixed gate bias and drain bias is supplied by the A+ (battery) voltage. The driver stage drives the final stage consisting of two transistors operating in parallel. Both devices have separate, fixed gate biases and their drain biases are supplied by the A+ voltage. The output of the final stage feeds the antenna switch which routes the RF PA to the harmonic filter/power detector/antenna and isolates the RX front-end in transmit mode. Antenna switch routes antenna/power detector/harmonic filter to RX and isolates TX in RX mode. Mode is determined via K9.1V. The harmonic filter is a low-pass filter that attenuates harmonics generated by the RF PA in transmit mode and provides additional receive selectivity in receive mode.

### 3.9.2 Power Control

Power is regulated by an automatic-level control (ALC) circuit. The transmitter ALC consists of a distributed power detector with a detection diode, buffer/amplifier, digital-to-analog converter (DAC), and loop integrator. During transmission, the RF PA gain and output power is adjusted by a control voltage. The power detector senses incident power transferred to the antenna via a directional coupler whose signal is converted to a DC voltage by the detection diode. This DC voltage is buffered/amplified and then added to the DAC voltage which is then compared to a fixed voltage reference. The carrier power level is set by adjusting the DAC voltage while monitoring the output power, which is saved in radio memory.

### 3.9.3 Circuit Protection

RF PA final-stage drain current, RF PA final-stage temperature, RF PA control voltage, and battery voltage are sensed by the power-control circuitry. If a fault condition is detected, the control voltage is reduced, which cuts back the output power to a level that is safe for the particular conditions.

### 3.9.4 DC Interconnect

The DC connector at the edge of the board carries the A+ supply for the entire board. This supply is routed directly to the controller and transmitter circuitry for both direct supply and regulating additional supplies. The radio chassis is grounded through the PCB screws and also via direct contact to the board. The control head receives the A+ supply through the 50-pin flex connector.

## 3.10 700–800 Receiver Overview

The receiver circuits primary duties are to detect, filter, amplify, and demodulate RF signals in the presence of strong interfering noise and unintended signals. The receiver is broken down into the following blocks:

- Front-end (preselector and LNA)
- Mixer
- IF
- Back-end IC

### 3.10.1 Receiver Front-End

The 700–800 MHz receiver front-end operates in two bands. The primary function of the front-end is to optimize image rejection and selectivity while providing the first conversion. The front-end uses ceramic filter technology and includes a wideband, monolithic amplifier. The first filter is a dual switched filter that reduces the image frequency response and limits some of the out-of-band interference. The second filter following the monolithic Low Noise Amplifier (LNA) provides additional image rejection.

### 3.10.2 Mixer

The signal is then fed to the monolithic Mixer IC where it is down converted to an IF of 73.35 MHz. The mixer is designed to provide low conversion loss and high intermodulation performance. The mixer is driven by the receiver injection buffer, a two-stage discrete IC design used with the receiver VCO to efficiently drive the mixer over a wide temperature range with minimum power variation. The injection buffer provides 15 dBm to the mixer. The VCO performs low-side injection for the 800 MHz band and high-side Injection for the 700 MHz band. The design maintains temperature stability, low insertion loss, and high out-of-band rejection.

### 3.10.3 IF Circuitry

The crystal filters provide IF selectivity and out-of-band signal protection to the back-end IC. Two 2-pole crystal filters centered at 73.35 MHz that are isolated from one another by a stable, moderate gain amplifier are used to meet the receiver specifications for gain, close-in intermodulation rejection, adjacent-channel selectivity, and second-image rejection.

### 3.10.4 Abacus III Back-End

The output of the IF circuit is fed directly to the Abacus III digital back-end IC. The ABACUS III is an IC with a variable-bandwidth bandpass Sigma-Delta architecture. It is capable of down-converting analog as well as digital RF protocols into a baseband signal transmitted on the Synchronous Serial Interface (SSI) bus. The Abacus III IC converts the 73.35 MHz signal from the IF section down to 2.25 MHz using a second LO frequency of 71.1 MHz or 75.6 MHz. The second LO VCO is tuned to 71.1 MHz (low side) or 75.6 MHz (high side injection). The choice of frequency depends on known spurious interference related to the programmed received frequency.

### 3.11 Frequency Generation Unit (FGU)

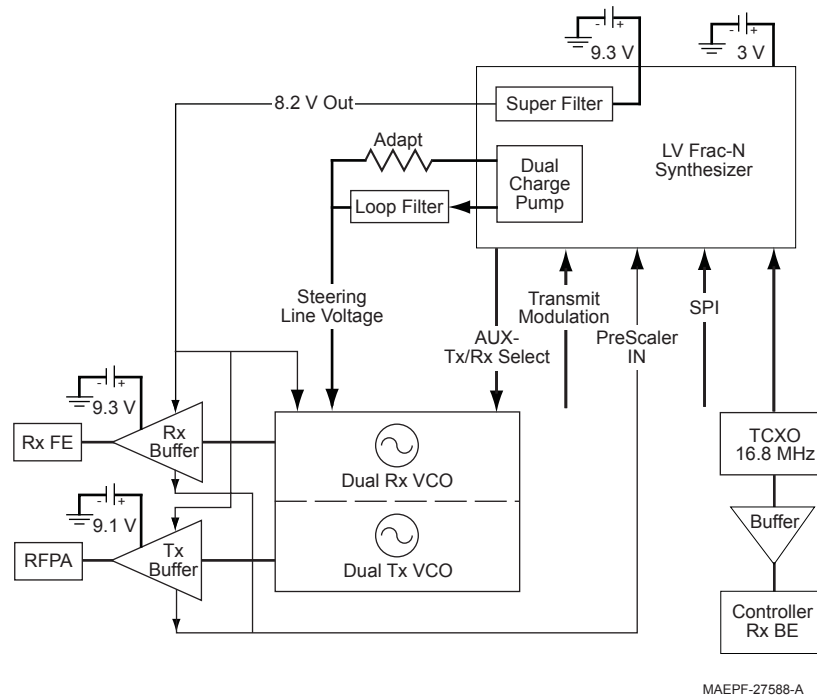


Figure 3-2. Frequency Generation Unit Diagram

The frequency generation unit (FGU) (Figure 3-2) is comprised of a fractional-N synthesizer IC, a 16.8 MHz reference oscillator IC, two voltage-controlled oscillator (VCO) modules (receive and transmit, containing two VCOs each), VCO buffer/amplifier circuits, and associated circuitry.

The reference oscillator IC provides a frequency standard to the fractional-N synthesizer IC, the Abacus III digital back-end IC and to the controller section. The synthesizer turns on one of the four VCOs (determined by mode and band of operation) and tunes it to the receiver (RX) local oscillator (LO) or transmitter (TX) carrier frequency.

The voltage-controlled oscillator (VCO) module employs a Colpitts configuration with two bipolar stages in a common-base, common-collector configuration. The LC tank circuit's capacitive portion consists of a varactor diode, coupling capacitor and a laser-trimmed capacitor for frequency adjustment. The inductive portion consists of microstrip transmission line resonators for TX VCO and coaxial resonators for RX VCO. Tuning is performed by the module manufacturer and is not field adjustable. The varactor changes the oscillator frequency when the DC voltage of the steering line changes. The output of the common base is coupled to the second transistor for impedance buffering, and its output is coupled to respective TX/RX buffer amplifiers.

In TX mode, the transmitter VCO output is coupled to a three-stage buffer before being injected into the power amplifier (see “3.9 Radio-Frequency Power Amplifier (RF PA) and Output Network (ON)” on page 3-9). In RX mode, the receiver VCO output is buffered and amplified with a two-stage transistor/microwave monolithic IC (MMIC) circuit. The output of the first-stage transistor is split into two paths. One path feeds back to the synthesizer prescaler; the other path is injected into the second-stage MMIC. The output of the MMIC provides the proper signal level for the LO port of the RX front-end mixer (see “3.10 700–800 Receiver Overview” on page 3-10).

The super filter supplies the voltage to the first two stages of the TX buffer and to the first-stage transistor of the RX buffer/amplifier. The voltage for the third stage of the TX buffer is supplied by a keyed 9.1 V source to conserve current drain while the radio is receiving. The second stage MMIC of the RX buffer/amplifier is supplied by a 9.3 V regulator.

## Notes

# Chapter 4 Test Equipment, Service Aids, and Tools

## 4.1 Recommended Test Equipment

The list of equipment contained in [Table 4-1](#) includes most of the standard test equipment required for servicing Motorola mobile radios, as well as several unique items designed specifically for servicing this family of radios. The *Characteristics* column is included so that equivalent equipment can be substituted; however, when no information is provided in this column, the specific Motorola model listed is either a unique item or no substitution is recommended.

*Table 4-1. Recommended Motorola Test Equipment*

Motorola Model Number	Description	Characteristics	Application
R-1439 or  R-1440 (See <a href="#">Table 4-2</a> for plug-in elements)	BIRD Wattmeter  BIRD Wattmeter	Power range: 100 mW to 100W, 2 MHz to 1GHz, UHF-F connector Power range: 100 mW to 100W, 2 MHz to 1GHz, N-female connector	Transmitter power measurements
R-1611	Dual-Channel 100 MHz Oscilloscope (Agilent)	Two-channel, 100MHz bandwidth, 200 Msample rate/sec., 2MB memory/channel	Waveform measurements
R-2670 (with options, as applicable)	System Analyzer	This item will substitute for items with an asterisk (*).	Frequency/deviation meter and signal generator for wide-range troubleshooting and alignment

[Table 4-2](#) contains a listing of the plug-in elements that are available for the BIRD wattmeters listed in the [Table 4-1](#).

*Table 4-2. Wattmeter Plug-In Elements*

Power	25-60 MHz	50-125 MHz	100-250 MHz	200-500 MHz	400-1000 MHz
5W	---		0180305F29	0180305F38	0180305F46
10W	---	0180305F22	0180305F30		0180305F47
25W	0180305F15	0180305F23	0180305F31	0180305F40	0180305F48
50W	0180305F16	0180305F24	0180305F32	0180305F41	0180305F49
100W	0180305F17	0180305F25	0180305F33	0180305F42	0180305F50
250W	0180305F18	0180305F26	0180305F34	0180305F43	0180305F51
500W	0180305F19	0180305F27	0180305F35	0180305F44	0180305F52
1000W	0180305F20	0180305F28	0180305F36	0180305F45	0180305F53

Table 4-3 contains a listing of non-Motorola test equipment recommended for servicing mobile radios.

Table 4-3. Recommended Non-Motorola Test Equipment

Model Number	Description	Application
	1:1 Audio Transformer	Audio measurement (audio PA must NOT be grounded)
Agilent 6552	Power Supply (0-20 V, 0-25 A)	Mobile radio power supply
Agilent 8901	Modulation Analyzer	Frequency, reference oscillator deviation and compensation measurements
Agilent 8903	Audio Analyzer	Audio signal-level, SINAD, and distortion measurements
Fluke 45	Bench-Top Digital Multimeter	AC/DC voltage and current measurements
Fluke 187 or 189	Handheld Digital Multimeter (True RMS, AC, AC+DC, dB)	AC/DC voltage and current measurements
Fluke 190 Series	Handheld Oscilloscope (60-200 MHz Bandwidth, 2.5 GS/sec, Built-in 500-Count True RMS Multimeter)	Waveform measurements
HP E4430	Digital I/Q Modulation Signal Source	Signal source for transmit and receive digital tests
Weinschel 49 30 43	30 dB RF Attenuator	For tests that require a modulation analyzer or wattmeter

## 4.2 Service Aids and Recommended Tools

Refer to the tables in this section for a listing and description of the service aids and tools designed specifically for servicing this family of radios, as well as the more common tools required to disassemble and properly maintain the radio. These kits and/or parts are available from the Motorola parts division offices listed in [Appendix A. Replacement Parts Ordering](#).

Table 4-4. Service Aids for XTL 5000 Board-Level Troubleshooting

Motorola Part Number	Description	Application
HKN6155	Programming Flash Cable	Used with Tuner Software, CPS, and FLASHport
RVN4185	Customer Programming Software and Tuner Software	Programming and radio alignment software on CD



Table 4-5. Recommended Motorola Tools for Board-Level Troubleshooting

Motorola Part Number	Tools and Supplies
0180386A82	Anti-static grounding kit
8180384N71	Chassis eliminator
	Control-head interconnect service cable
1185984D01	Electromagnetic Interference (EMI) metallic shielding tape, or equivalent
0180320B16	Magnetic screwdriver set with bits
3085651A01	Mini-UHF to N-type adapter cable
6686119B01	Plastic scraping tool
6680163F01	Removal and insertion tool
RSX4043	Roto-Torq adjustable torque driver

Table 4-6. Recommended Non-Motorola Tools for Board-Level Troubleshooting

Part Number	Tools and Supplies
	2.5 mm hex-key bit
	Flat-blade screwdriver
	Small, flat-blade screwdriver
MA-800G	Solder aid, (black stick), Hexacon Electric Co.
	Torx® T10 and T20 drivers

## 4.3 Field Programming Equipment

The ASTRO family of radios can be aligned and programmed in the field. This requires specific equipment and special instructions. Refer to the online help in the Customer Programming Software (RVN4185).

### 4.3.1 XTL 5000 Field Programming

The XTL 5000 radios use a flash memory device to store information on frequencies, squelch codes, signaling codes, time-out timer durations, and other parameters.

The XTL 5000 radios can be programmed in the field any number of times without removing the flash memory from the radio.

#### 4.3.1.1 Dash-Mounted Radios

To program and tune a dash-mounted XTL 5000 radio, the HKN6155 cable is connected to the radio via the microphone connector. The opposite end of the cable is connected to an IBM or IBM PC-compatible computer. Another programming option is to connect a direct adapter cable to the radio's rear accessory connector, J2, and connect the other end to the computer. (Please refer to the CPS Programming Installation Guide—Motorola part number 6881095C44—for installation and setup procedures for the software.)

### 4.3.1.2 Remote-Mounted Radios

For remote-mounted radios, the cable is connected to the radio at the FLASHport connector, which is located on the remote faceplate of the transceiver. Another programming option is to use a direct adapter cable to connect the radio's rear accessory connector, J2, to the computer. A third option is to use an ASTRO Packet Data cable to directly connect J6 on the remote faceplate to the computer. (Please refer to the CPS Programming Installation Guide—Motorola part number 6881095C44—for installation and setup procedures for the software.)

Do not attempt to program via the remote control head. Be sure to disconnect any accessories that are connected to the radio's microphone ports (including the microphones). Bias to these accessories could impair programming/tuning capability.

### 4.3.1.3 Field-Programming Items

Once the computer is connected to the radio, the prompts provided by the programming software can be followed. The following items, available through the Radio Products Services Division (except the computer), are required when programming XTL 5000 radios.

*Table 4-7. XTL 5000 Radio Field-Programming Items*

Type or Part Number	Description
HKN6155 Programming Cable	Used to connect radio directly to the computer.
Computer, IBM or IBM PC-compatible	
RVN4185 Customer Programming Software and Tuner Software	This software enables you to program the radio's features and align its parameters.

### 4.3.1.4 W3 Control-Head Error Message

For a radio equipped with a W3 control head, it is possible for the message FL01/90 to display while using the HKN6155 programming cable for tuner, CPS, or flash programming. Upon completion of the operation, a reset will clear the message. Powering on the radio before attaching the programming cable will decrease the occurrence of the FL01/90 message.

---

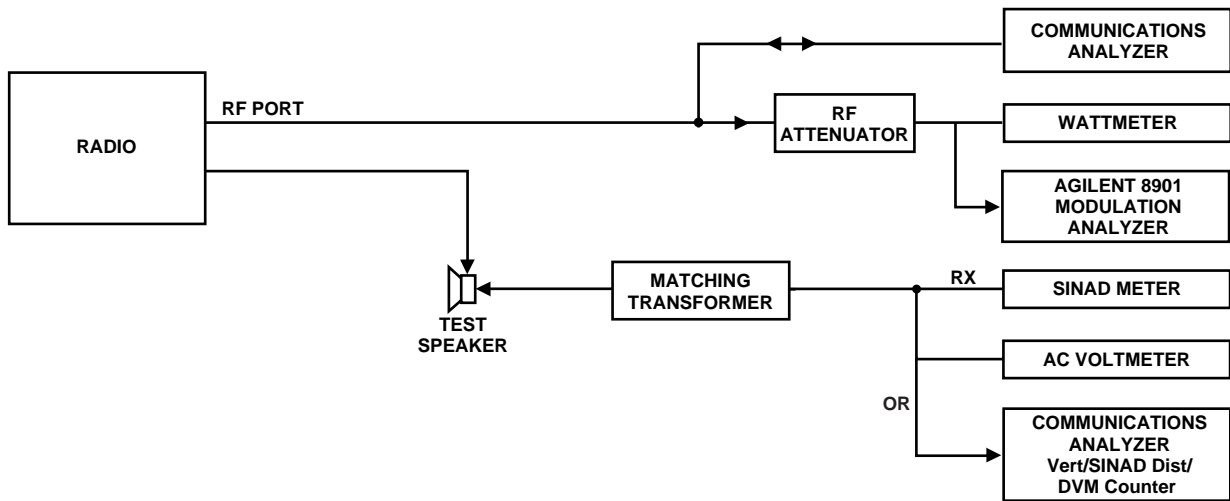
# Chapter 5 Performance Checks

## 5.1 Introduction

This section covers performance checks used to verify that the radio meets published specifications. The recommended test equipment listed in the [Chapter 4](#) approaches the accuracy of the manufacturing equipment, with a few exceptions. Accuracy of the equipment must be maintained in compliance with the manufacturer's recommended calibration schedule.

## 5.2 Test Setup


The equipment required for XTL 5000 radio performance checks is connected as shown in the following diagram.



MAEPF-27656-O

Figure 5-1. Performance Checks Test Setup

## 5.3 Test Mode



**Caution** Be sure to transmit into a load when keying a radio under test.

### 5.3.1 Entering Test Mode

1. To enter test mode, turn the radio on.
  2. Within 10 seconds after Self Test is complete, press the **Home** button five times in succession.
  3. The radio will show a series of displays that will give information regarding various version numbers and subscriber-specific information. The displays are described in [Table 5-1](#) on [page 5-2](#).
-

Table 5-1. Test-Mode Displays

Display Name	Description	Appears
SERVICE	Indicates the radio has entered test mode	Always
Radio Host Software Version	The version of radio firmware	Always
DSP Software Version	The version of firmware being used by the DSP	Always
EMC Secure Version	Version of the encryption hardware	When the radio is secure equipped
Encryption Firmware	Firmware version for encryption	When the radio is secure equipped
Encryption Type 1	Type of encryption being used	When the radio is secure equipped
Encryption Type 2	Type of encryption being used	When the radio is secure equipped
Control Head Version	Control head firmware version number	Always
Auxiliary Control Head	Firmware version for the auxiliary control head	When an auxiliary control head is present
Siren Version	Firmware version for the siren	When a siren is present
VRS Version Number	Firmware version for the VRS	When VRS is present
Model Number	The radio's model number, as programmed in the codeplug	Always
Serial Number	The radio's serial number, as programmed in the codeplug	Always
ROM Size	Memory capacity of the flash port	Always
FLASHcode	The FLASHcodes, programmed as a part of the radio's codeplug	Always

Note: All displays are temporary and will expire without any user intervention. If the information is longer than the physical length of the control head display, it will wrap around to the next display. After the last display, RF TEST will be displayed.

- Pressing the **Mode** rocker will cause the displays to stop. The test mode menu, CH TEST, will be displayed.

5. Pressing the **Home** button will cause the displays to stop. The RF test mode will be entered. The display will show 1 CSQ, indicating test frequency 1, Carrier Squelch mode.
6. Go to the **RF Test Mode** section.

### 5.3.2 RF Test Mode

A special routine, called **RF TEST MODE** or *air test*, has been incorporated in the radio.

1. **Enter the RF test mode by pressing the Home button when the test mode menu RF TEST is displayed. Use the Mode rocker to cause the radio to display the test mode menu, RF TEST, if the display reads CH TEST.**
2. Press the **Home** button to move the cursor back and forth between the frequency and signaling type (See [Table 5-2](#) on this page and [Table 5-3](#) on page 5-4). The first digit will flash to indicate which type is currently selected. Press the **Mode** button to scroll through the available selections.

*Table 5-2. Test Frequencies*

Test Channel	700/800 MHz
TX #1	762.0125
RX #1	762.0625
TX #2	769.0125
RX #2	769.0625
TX #3	775.9875
RX #3	775.9375
TX #4	794.0125
RX #4	851.0625
TX #5	805.9875
RX #5	860.0625
TX #6	806.0125
RX #6	860.0625
TX #7	823.9875
RX #7	869.9375
TX #8	851.0125
RX #8	851.0625
TX #9	860.0125
RX #9	860.0625
TX #10	869.8875
RX #10	869.9375

Table 5-3. Signaling Types

Display	Modulation	Demodulation	Type
CSQ	None	None	Carrier Squelch
TPL	192 Hz	192 Hz	Private-Line
AST	1200 Hz	N/A	ASTRO (digital)
USQ	None	None	Open Squelch

When in the transmit test mode, DTMF modulation produces a sidetone in the speaker. All signaling types will continually modulate the transmitted signal for detection/measurement by external instruments.

### 5.3.3 Control Head Test Mode

The control head test mode is part of the diagnostics built into the radio and is entered through the front panel programming sequence. This test mode allows you to perform button and display tests to verify proper operation.

1. Enter the control head test mode by pressing the **Home** button when the test mode menu, CH TEST, is displayed. Use the **Mode** rocker to cause the radio to display the test mode menu, CH TEST, if the display reads RF TEST.
2. Press the **Mode** switch to change the test mode from the RF test mode to the control head test mode (CH TEST).

**NOTE:** Once the **CH Test** has been selected by pressing **Home**, pressing the **Mode** switch will not change the control head test mode back to the RF test mode. You must turn the radio off and reenter the RF test mode as described earlier.

3. When the control head test mode is selected (CH TEST), press the **Home** button. The display will show the interpreted key number. Status of the key press is indicated to the right of the key number.

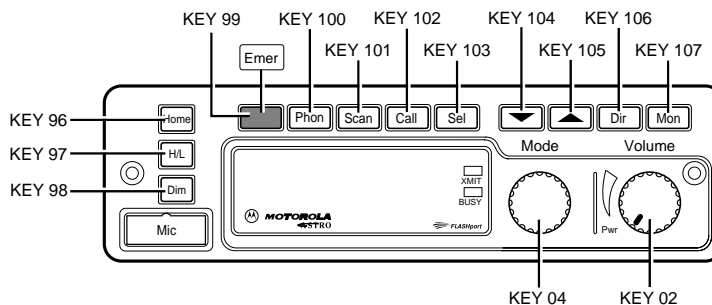


Figure 5-2. W4 Control-Head Key-Closure Displays

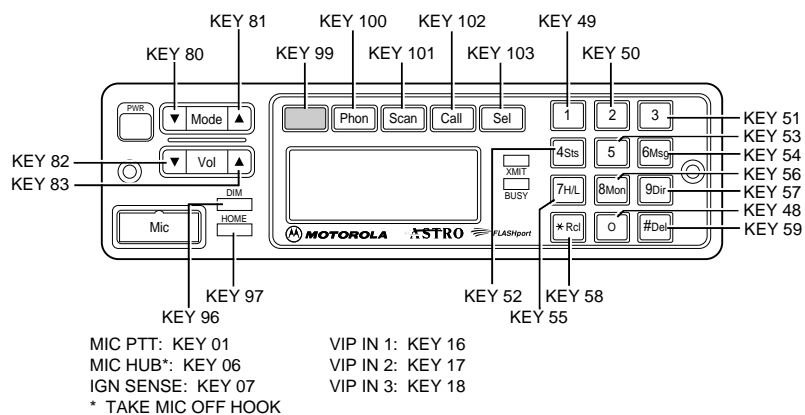


Figure 5-3. W5 and W7 Control-Head Key-Closure Displays

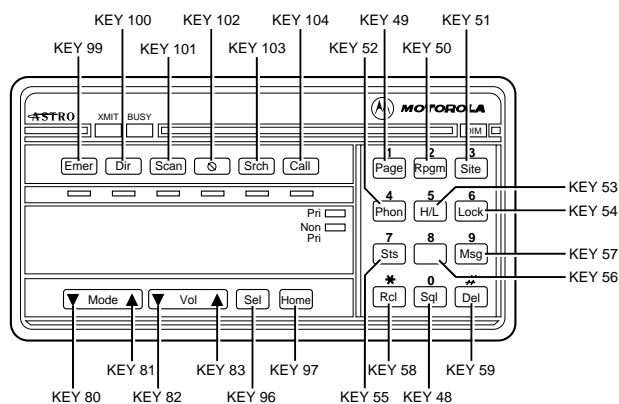


Figure 5-4. W9 Control-Head Key-Closure Displays

- Switch the radio power off temporarily to exit the test mode and return to normal radio operation.

## 5.4 Receiver Performance Checks

Table 5-4. Receiver Performance Checks

Test Name	System Analyzer	Radio	Test Condition	Comments
Reference Frequency	Mode: PWR MON 1st channel test frequency* Monitor: Frequency error Input at RF In/Out	TEST MODE, 1 CSQ output at antenna	Press and hold PTT switch.	Frequency error to be $\pm 150$ Hz (800 MHz)
Rated Audio	Mode: GEN Output level: 1.0 mV RF 1st channel test frequency* Mod: 1 kHz tone at 3 kHz deviation Monitor: DVM: AC Volts	TEST MODE, 1 CSQ	Release PTT switch.	Set volume control to 6.3 Vrms across the 3.2 ohm speaker
Distortion	As above, except to distortion	TEST MODE, 1 CSQ	Release PTT switch.	Distortion < 3.0%

Table 5-4. Receiver Performance Checks (Continued)

Test Name	System Analyzer	Radio	Test Condition	Comments
Sensitivity (SINAD)	As above, except SINAD, lower the RF level for 12 dB SINAD	TEST MODE, 1 CSQ	Release PTT switch.	RF input to be < 0.25 $\mu$ V
Noise Squelch Threshold (only radios with conventional system need to be tested)	RF level set to 1 mV RF	TEST MODE, 1 CSQ	Release PTT switch.	Set volume control to 3.16 Vrms across the speaker.
	As above, except change frequency to a conventional system. Raise RF level from zero until radio unsquelches.	Out of TEST MODE; select a conventional system	Release PTT switch.	Unsquelch to occur at < 0.25 $\mu$ V

\* Test frequencies are listed in [Table 5-2](#).

## 5.5 Transmitter Performance Checks

Table 5-5. Transmitter Performance Checks

Test Name	System Analyzer	Radio	Test Condition	Comments
Reference Frequency	Mode: PWR MON 1st channel test frequency** Monitor: Frequency error Input at RF In/Out	TEST MODE, 1 CSQ	Press and hold PTT switch.	Frequency error to be $\pm$ 150 Hz (800 MHz)
Power RF	As above	TEST MODE, 1 CSQ	Press and hold PTT switch.	Refer to the Radio Specifications in the front of the manual.
Voice Modulation	Mode: PWR MON 1st channel test frequency** atten to -70, input to RF In/Out, Monitor: DVM, AC Volts Set 1 kHz Mod Out level for 0.025 Vrms at test set, 80 mVrms at dummy microphone or load box input	TEST MODE, 1 CSQ	Press and hold PTT switch.	Deviation: 800 MHz: $\geq$ 3.6 kHz but $\leq$ 5.0 kHz See the Detailed Service Manual for test equipment descriptions.
Voice Modulation (internal)	Mode: PWR MON 1st channel test frequency** atten to -70, input to RF In/Out	TEST MODE, 1 CSQ, output at antenna	Remove modulation input from dummy microphone or load box. Press and hold PTT switch.	Press PTT switch on microphone and say "four" loudly into the radio mic. Measure deviation: 800 MHz: $\geq$ 3.8 kHz but $\leq$ 5.0 kHz See the Detailed Service Manual for test equipment descriptions.



Table 5-5. Transmitter Performance Checks (Continued)

Test Name	System Analyzer	Radio	Test Condition	Comments
PL Modulation (radios with conventional, clear mode, coded squelch operation only)	Change frequency to 1st channel test frequency**; B/W to narrow	TEST MODE, 1 TPL	Remove modulation input from dummy microphone or load box. Press and hold PTT switch.	Deviation: 800 MHz: >= 500 Hz but <= 1000 Hz See the Detailed Service Manual for test equipment descriptions.
Talkaround Modulation (radios with conventional, clear mode, talkaround operation only)	Change frequency to conventional talkaround frequency. Mode: PWR MON deviation, attenuation to -70, input to RF In/Out Monitor: DVM, AC Volts Set 1 kHz Mod Out level for 8 mVrms at dummy microphone or load box.	Conventional talkaround personality (clear mode operation) 1 CSQ	Press and hold PTT switch.	Deviation: 800 MHz: >= 3.8 kHz but <= 5.0 kHz See the Detailed Service Manual for test equipment descriptions.
Talkaround Modulation (radios with conventional, secure mode, talkaround operation only) *	Change frequency to conventional talkaround frequency. Mode: PWR MON deviation, attenuation to -70, input to RF In/Out Monitor: DVM, AC Volts Mod: 1 kHz out level for 80 mVrms at dummy microphone or load box.	Conventional talkaround personality (secure mode operation). Load key into radio 1 sec.	Press and hold PTT switch.	Deviation: 800 MHz: >= 3.6 kHz but <= 4.4 kHz See the Detailed Service Manual for test equipment descriptions.

\* The secure mode, talkaround modulation test is only required for radios that do not have clear mode talkaround capability.

\*\* Test frequencies are listed in [Table 5-2](#).

## Notes

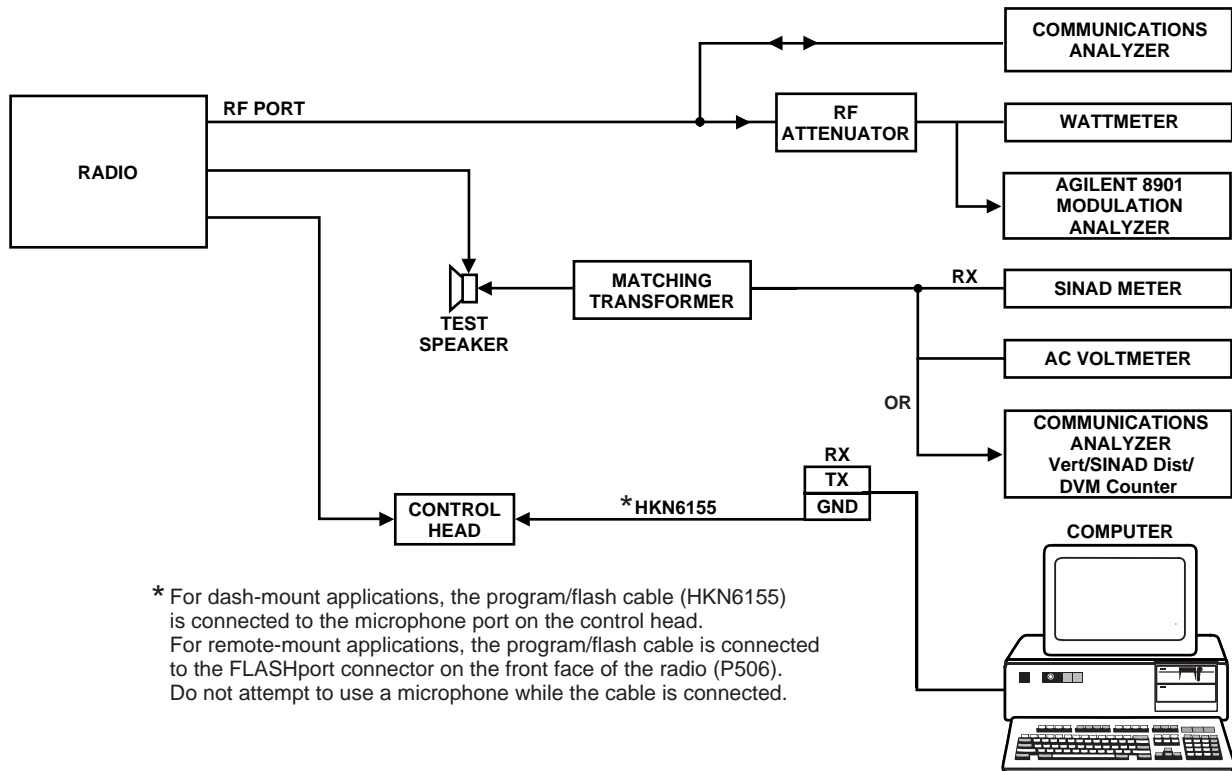
# Chapter 6 Radio Alignment Procedures

## 6.1 Introduction

This section describes both receiver and transmitter radio alignment procedures.

## 6.2 ASTRO XTL 5000 Tuner Software


A personal computer (PC) and Tuner Software are required to align the radio. Please refer to the *CPS Programming Installation Guide* (Motorola part number 6881095C44) for installation and setup procedures for the software. To perform the alignment procedures, the radio must be connected to the computer and to a universal test set, as shown in the following figure.




\* For dash-mount applications, the program/flash cable (HKN6155) is connected to the microphone port on the control head. For remote-mount applications, the program/flash cable is connected to the FLASHport connector on the front face of the radio (P506). Do not attempt to use a microphone while the cable is connected.

MAEPF-27657-O

Figure 6-1. Radio Alignment Test Setup



**Caution** These procedures should only be attempted by qualified service personnel. Failure to perform alignment procedures properly may result in seriously degraded radio or system performance.

Select **Tuner** from the **Start** menu. To read the radio, use the **File** → **Read Device** menu or click on . [Figure 6-2 on page 6-2](#) illustrates how the alignment screens are organized. To access a screen, double-click on the desired screen name in the **Tuner** menu.

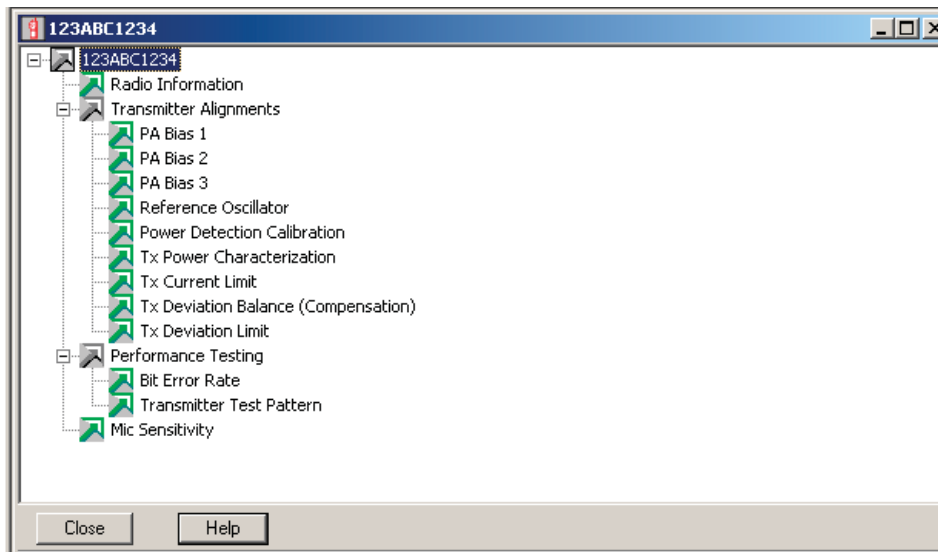


Figure 6-2. Tuner Main Menu

The alignment screens utilize the “softpot,” an analog **SOFT**ware-controlled **POT**entiometer used for adjusting all transceiver alignment controls.

	<p>Do NOT switch radios in the middle of any alignment procedure. Always left-click the <b>Close</b> button on the screen to return to the Tuner Main Menu screen before disconnecting the radio. Improper exits from the Alignment screens may leave the radio in an improperly configured state and result in seriously degraded radio or system performance.</p>
<p><b>Caution</b></p>	

Each alignment screen provides the ability to increase or decrease the softpot value by using the **slider** or the **spin buttons** (▲ and ▼), or by entering the new value from the keyboard. A graphical scale on the display indicates the minimum, maximum, and proposed value of the softpot.

## 6.3 Radio Information

Figure 6-3 shows a typical Radio Information screen. All of the data appearing here is informational and cannot be changed.

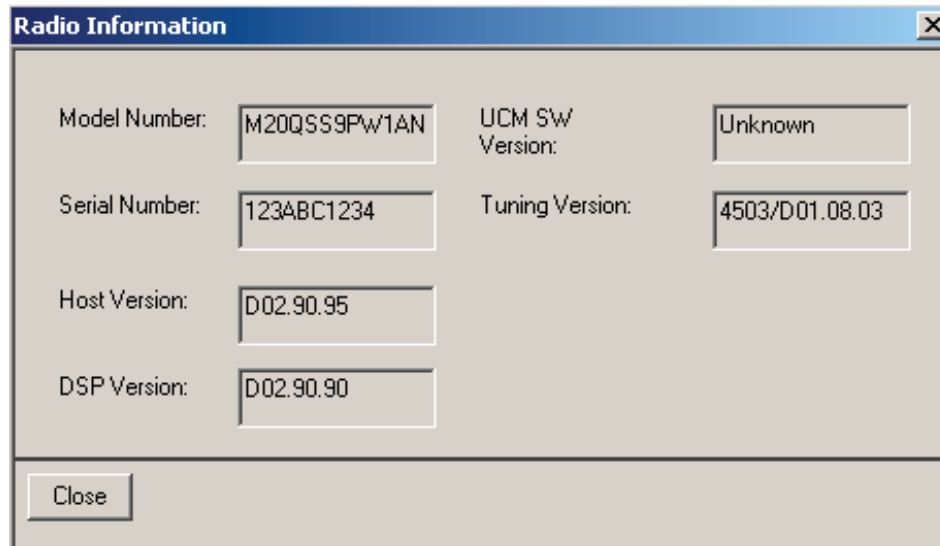


Figure 6-3. Radio Information Screen

## 6.4 Transmitter Alignments

### 6.4.1 PA Bias 1 Alignment

**NOTE:** This alignment is required after replacing (or servicing) the transceiver board.

The PA Bias 1 alignment procedure adjusts the drain bias current in one of the RF power amplifier devices:

Table 6-1. PA Bias 1 Alignment RF Power Amplifier Devices

Band/Power Level	Device
700–800 MHz 35 W/15 W Motorcycle	Final1

**NOTE:** The antenna port should be terminated with a 50-ohm load while tuning.

1. Set the power supply voltage as indicated in Table 6-2. Set power supply current limit to 3 A.

Table 6-2. Power Supply Voltage Settings

Band/Power Level	Supply Voltage (V)	Supply Current Limit (A)
700–800 MHz 35 W/15 W Motorcycle	13.6	15

2. Select **PA Bias 1** from the Tuner Main Menu. When the screen is opened, the radio enters a special bias tune mode and radio current increases by approximately 100 mA.

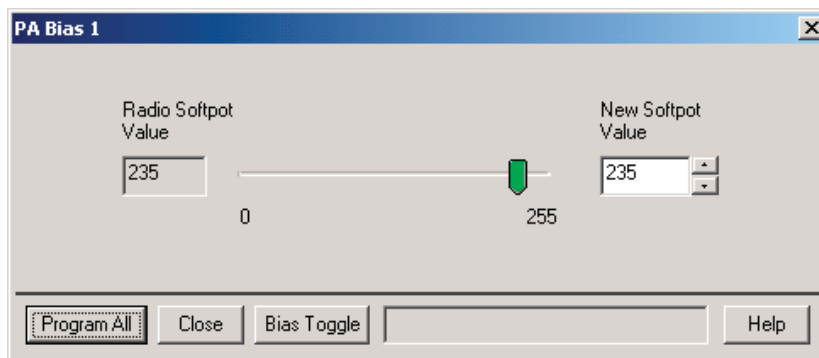


Figure 6-4. PA Bias 1 Alignment Screen

3. Read baseline current from current meter on power supply.
4. Add baseline current to device bias current to calculate target current.

Table 6-3. PA Bias 1 Alignment Device Bias Current

Band/Power Level	Device bias current (mA)
700–800 MHz 35 W/15 W Motorcycle	250

5. Left-click the **Bias Toggle** button to apply bias to gate of device.
6. Adjust softpot value until target current is achieved within  $\pm 10\%$
7. Left-click the **Bias Toggle** button to remove bias from gate of device.
8. Left-click the **Program All** button to save tuned value.
9. Left-click **Close** button to close the screen and return to the Tuner Main Menu.

## 6.4.2 PA Bias 2 Alignment

**NOTE:** This alignment is required after replacing (or servicing) the transceiver board.

The PA Bias 2 alignment procedure adjusts the drain bias current in one of the RF power amplifier devices:

Table 6-4. PA Bias 2 Alignment Amplifier Devices

Band/Power Level	Device
700–800 MHz 35 W/15 W Motorcycle	Final2

**NOTE:** The antenna port should be terminated with a 50-ohm load while tuning.

1. Set the power supply voltage as indicated in [Table 6-5](#). Set power supply current limit to 3 A.

Table 6-5. Power Supply Voltage Settings

Band/Power Level	Supply Voltage (V)	Supply Current Limit (A)
700–800 MHz 35 W/15 W Motorcycle	13.6	15

2. Select **PA Bias 2** from the Tuner Main Menu. When the screen is opened, the radio enters a special bias tune mode and radio current increases by approximately 100 mA.

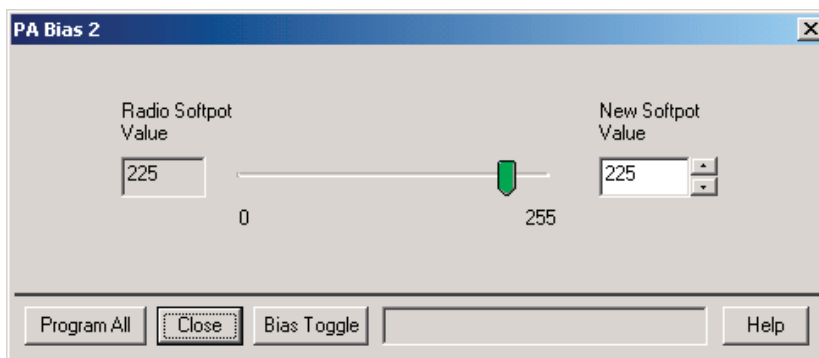


Figure 6-5. PA Bias 2 Alignment Screen

3. Read baseline current from current meter on power supply.
4. Add baseline current to device bias current to calculate target current.

Table 6-6. PA Bias 2 Alignment Device Bias Current

Band/Power Level	Device bias current (mA)
700–800 MHz 35W/15W Motorcycle	250

5. Left-click the **Bias Toggle** button to apply bias to gate of device.
6. Adjust softpot value until target current is achieved within  $\pm 10\%$
7. Left-click the **Bias Toggle** button to remove bias from gate of device.
8. Left-click the **Program All** button to save tuned value.
9. Left-click **Close** button to close the screen and return to the Tuner Main Menu.

### 6.4.3 PA Bias 3 Alignment

**NOTE:** This alignment is required after replacing (or servicing) the transceiver board.

The PA Bias 3 alignment procedure adjusts the drain bias current in one of the RF power amplifier devices:

Table 6-7. PA Bias 3 Alignment Amplifier Devices

Band/Power Level	Device
700–800 MHz 35 W/15 W Motorcycle	Driver

**NOTE:** The antenna port should be terminated with a 50-ohm load while tuning.

1. Set the power supply voltage as indicated in [Table 6-8](#). Set power supply current limit to 3 A.

Table 6-8. Power Supply Voltage Settings

Band/Power Level	Supply Voltage (V)	Supply Current Limit (A)
700–800 MHz 35 W/15 W Motorcycle	13.6	15

2. Select **PA Bias 3** from the Tuner Main Menu. When the screen is opened, the radio enters a special bias tune mode and radio current increases by approximately 100 mA.

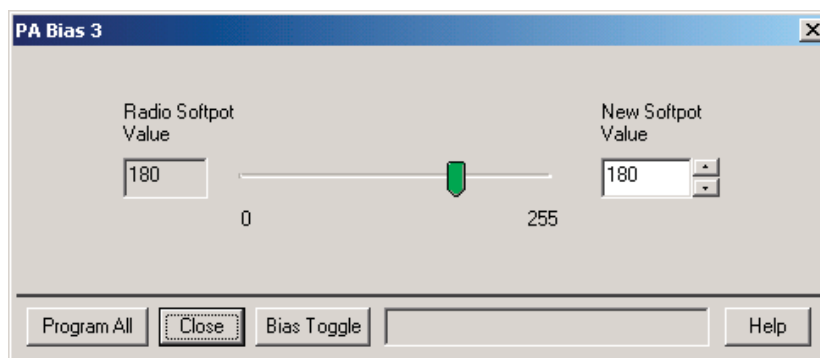


Figure 6-6. PA Bias 3 Alignment Screen

3. Read baseline current from current meter on power supply.
4. Add baseline current to device bias current to calculate target current.

Table 6-9. PA Bias 3 Alignment Device Bias Current

Band/Power Level	Device bias current (mA)
700–800 MHz 35 W/15 W Motorcycle	100

5. Left-click the **Bias Toggle** button to apply bias to gate of device.
6. Adjust softpot value until target current is achieved within  $\pm 10\%$
7. Left-click the **Bias Toggle** button to remove bias from gate of device.
8. Left-click the **Program All** button to save tuned value.
9. Left-click **Close** button to close the screen and return to the Tuner Main Menu.

#### 6.4.4 Reference Oscillator Alignment

Radios are shipped from the factory with a worst-case frequency error of  $\pm 500$  Hz for 700–800 MHz. These specifications are tighter than the more stringent FCC requirements of  $\pm 1.5$  ppm for the 700–800 MHz bands.

For radios that have been in storage for over six months from the factory ship date, the reference oscillator should be checked when the radio is initially deployed to the field. It is strongly recommended that the reference oscillator be checked every time the radio is serviced or at least once a year, whichever comes first.

The crystal contained in the reference oscillator naturally drifts over time due to its aging characteristic. Periodic (annual) adjustment of the reference oscillator is important for proper radio operation.

Improper adjustment can result in both poor performance and interference with other users operating on adjacent channels.



This test can be done with either the R-2670 Communication Analyzer or the Agilent 8901 Modulation Analyzer.

- Initial set up using the R-2670 Communication Analyzer:
    - RF Control: MONITOR
    - B/W: WB
    - Freq: RSS frequency under test
    - Attenuation: 20dB
    - Mon RF in: RF I/O
    - Meter: RF Display
    - Mode: STD
    - Input Level: uV or W
    - Display: Bar Graphs
    - Squelch: Mid-range or adjust as necessary
  - Initial set up using the Agilent 8901 Modulation Analyzer:
    - Press the green Automatic Operation button on the analyzer.
    - Press the **FREQ** key.
    - Type 7.1 followed by the **SPCL** button to set the 8901 Modulation Analyzer for maximum accuracy.
1. Select **Reference Oscillator** from the Tuner Main Menu (Figure 6-7).

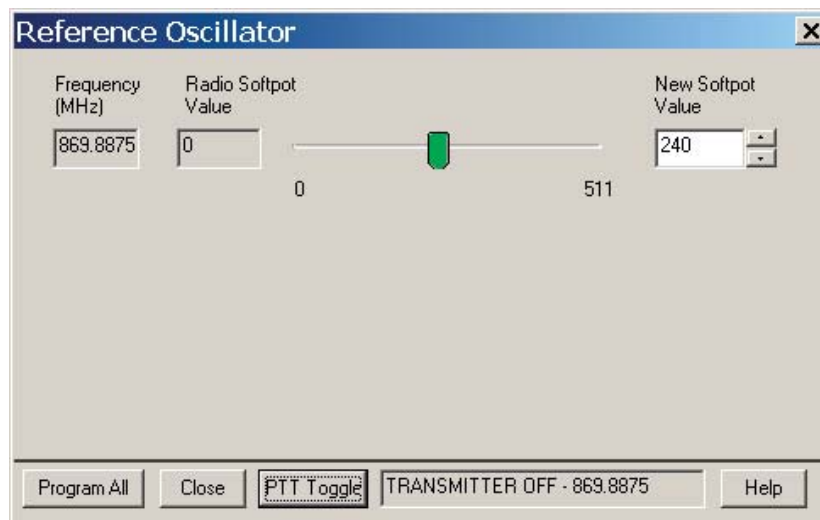


Figure 6-7. Reference Oscillator Window

2. If you are using the R-2670 analyzer, enter the frequency displayed on the Tuner screen in the "RF control" section of the R-2670. Under the "Meter" section of the display, choose RF DISPLAY.
3. Left-click the **PTT Toggle** button on the screen to make the radio transmit. The screen indicates whether the radio is transmitting.
4. Wait five seconds until the analyzer reading stabilizes, and then record the transmitter frequency.

- Adjust the reference oscillator's softpot value until the measured value is as close as possible to the frequency shown on the screen. Allow approximately five seconds for the analyzer frequency reading to stabilize after each change. See [Table 6-10](#).

Table 6-10. Reference Oscillator Alignment

Band	Target
800 MHz	±100 Hz

- Left-click the **Program All** button on the screen to dekey the radio and save the tuned values.
- Left-click the **Close** button on the screen to return to the Tuner Main Menu.

### 6.4.5 Power Detector Calibration

**NOTE:** This alignment is required after replacing (or servicing) the transceiver board.

The power detector calibration alignment procedure adjusts the buffer gain for the forward power detector to minimize radio power variation from radio to radio.

**NOTE:** Antenna port should be terminated with calibrated power meter through a 30 db RF pad.

- Set the power supply voltage and current limit as indicated in [Table 6-11](#).

Table 6-11. Power Supply Voltage Settings

Band/Power Level	Supply Voltage (V)	Supply Current Limit (A)
700–800 MHz 35 W/15 W Motorcycle	13.6	15

- Select **Power Detection Calibration** from the Tuner Main Menu.

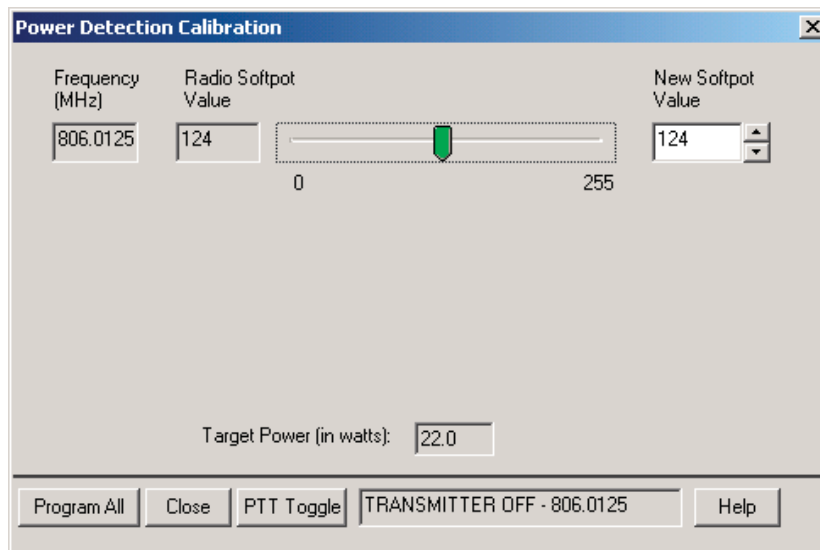


Figure 6-8. Power Detection Calibration Alignment Screen

- Left-click the **PTT Toggle** button to transmit at indicated frequency.
- Adjust softpot value until target power is achieved.
- Left-click the **PTT Toggle** button to disable transmit mode.

6. Left-click the **Program All** button to save tuned value.
7. Left-click **Close** button to close screen and return to the Tuner Main Menu.

### 6.4.6 Tx Power Characterization

**NOTE:** This alignment is required after replacing (or servicing) the transceiver board.

The Tx Power Characterization alignment procedure characterizes power tuning so that Tx power can be adjusted with CPS software. You will transmit at two power levels for each test frequency and record the measured power level with 0.1 W resolution.

**NOTE:** The antenna port should be terminated with a calibrated power meter through a 30 db RF pad.

1. Set the power supply voltage and current limit as indicated in [Table 6-12](#).

*Table 6-12. Power Supply Voltage Settings*

Band/Power Level	Supply Voltage (V)	Supply Current Limit (A)
700–800 MHz 35 W/15 W Motorcycle	13.6	15

2. Select **Tx Power Characterization** from the Tuner Main Menu.

Frequency (MHz)	Measured Power 1 (in watts)	Measured Power 2 (in watts)
762.0125	0	0
769.0125	0	0
775.9875	0	0
794.0125	0	0
805.9875	0	0
806.0125	0	0
823.9875	0	0
851.0125	0	0
860.0125	0	0
869.8875	0	0

Program All Close PTT Toggle TRANSMITTER OFF - 762.0125 Help

*Figure 6-9. Tx Power Characterization Alignment Screen*

3. Left-click in the first box of the Measured Power 1 column. A green circle will appear to the left of box indicating active characterization point.

4. Left-click the **PTT Toggle** button to transmit at indicated frequency and record power measurement with 0.1 W resolution. The green circle will turn red indicating that the radio is transmitting.
5. Left-click the **PTT Toggle** button to disable transmit mode.
6. Enter the power measurement with 0.1 W resolution overwriting any value that may reside in the box from previous tuning.
7. Left-click in the first box of the Measured Power 2 column. The green circle will move to the left of this box indicating it has become active characterization point.
8. Repeat steps 4-6.
9. Repeat steps 3-8 for the remaining frequencies.
10. Left-click the **Program All** button to save tuned value.
11. Left-click **Close** button to close screen and return to the Tuner Main Menu.

### 6.4.7 Tx Current Limit

**NOTE:** This alignment is required after replacing (or servicing) the transceiver board or after there has been a change in the CPS-adjustable power level.

The Tx Current Limit alignment procedure tunes the Tx current-limiting protection. If you increase the CPS-adjustable power level, then the current limit must be retuned so the radio can achieve the desired power level. If you decrease the CPS-adjustable power level, the current limit can be retuned to increase protection. You must first determine the test frequency at which maximum transmit current occurs and then tune on that test frequency.

**NOTE:** The antenna port should be terminated with a calibrated power meter through a 30 dB RF pad.

1. Set the power supply voltage and current limit as per [Table 6-13](#).

*Table 6-13. Power Supply Voltage Settings*

Band/Power Level	Supply Voltage (V)	Supply Current Limit (A)
700–800 MHz 35 W/15 W Motorcycle	13.6	15

2. Select **Tx Current Limit** from the Tuner Main Menu.

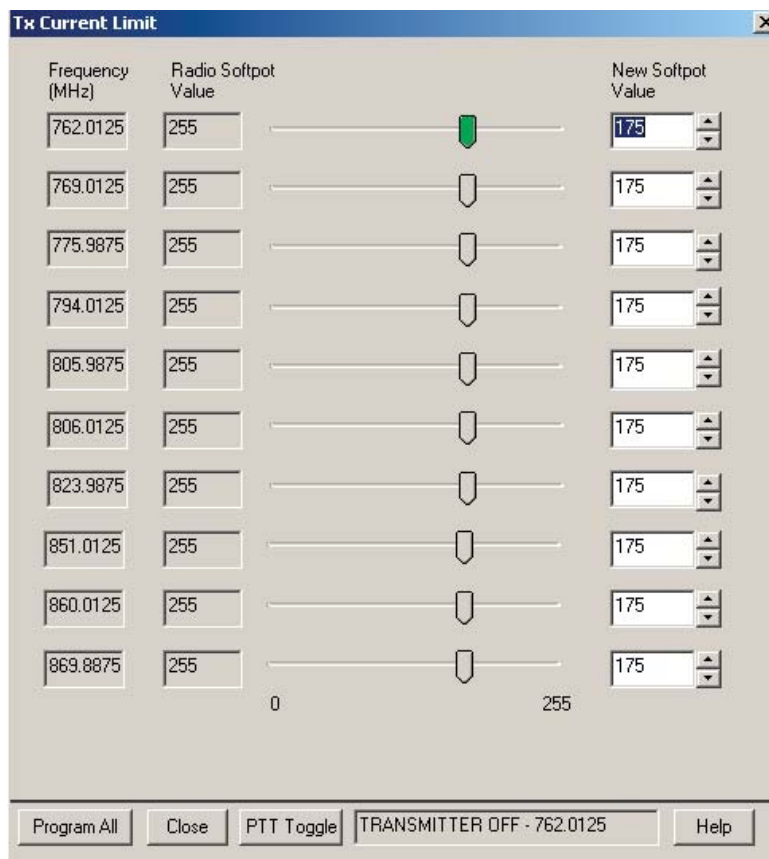


Figure 6-10. Tx Current Limit Alignment Screen

3. Use a slider or the spin buttons to change any one softpot value to 255.
4. Left-click the **Program All** button to save the tuned value. All softpots will change to 255, and transmit-current limiting will be disabled.
5. Left-click in upper softpot box.
6. Left-click the **PTT Toggle** button to transmit and record radio the transmit current drain. The tuner software uses a high CPS-adjustable power-level setting when transmitting.
7. Left-click the **PTT Toggle** button to disable transmit mode.
8. Repeat steps 6-8 for each test frequency to determine the frequency at which maximum transmit current drain occurs.
9. Once the proper test frequency is determined, left-click the **PTT Toggle** button to transmit and record transmit power on that test frequency.
10. Decrease the softpot value until transmit power degrades by 5%, and then left-click the **PTT Toggle** button to disable transmit.
11. Increase the softpot value to set the proper operating head room.

Table 6-14. Transmit Current Limit Offset

Band/Power Level	Current Limit Offset
700–800 MHz 35 W/15 W Motorcycle	8

12. Left-click the **Program All** button to save tuned value.
13. Left-click the **Close** button to close screen and return to the Tuner Main Menu.

Table 6-15. Transmit Current Limit Devices

Band/Power Level	Devices		
700–800 MHz 35 W/15 W Motorcycle	Final1	Final2	Driver

### 6.4.8 Tx Deviation Balance (Compensation)

**NOTE:** This alignment is required after replacing (or servicing) components on the transceiver board.

The Tx Deviation Balance (Compensation) alignment procedure balances the modulation contributions of the low- and high-frequency portions of a baseband signal. Proper alignment is critical to the operation of signaling schemes that have very low frequency components (for example, DPL) and could result in distorted waveforms if improperly adjusted. This procedure needs to be performed at multiple frequencies to allow for proper alignment across the entire RF band. The RF band is divided into frequency zones with a calibration point (value) in each zone. When performing this tuning procedure the **PTT Tone Low** generates an 80 Hz modulation frequency. The deviation level of this 80 Hz tone is used as the reference level for adjusting the deviation level of the **PTT Tone High**, which is a 3 kHz modulation frequency.

This test can be done with either the R-2670 Communication Analyzer or the Agilent 8901 Modulation Analyzer. The method of choice is the R-2670 Analyzer.

- Initial set up using the R-2670 Communication Analyzer:
  - Connect a BNC cable between the "DEMOD OUT" port and the "VERT/SINAD DIST/DMM COUNTER IN" port on the R-2670.
  - Press the SPF key on the R-2670 to display the "SPECIAL FUNCTIONS MENU." Move the cursor to "High Pass," and select 5 Hz on the soft key menu. Select 20 kHz for the "Low Pass" setting.
  - In the "RF Control" section of the R-2670, enter the frequency displayed on the Tuner screen. Move the cursor to the "B/W" setting and select "WIDE  $\pm 100$  kHz" on the soft key menu.
  - Place the R-2670 cursor in the "Display" zone. Select "AC VOLTS" on the soft key menu. Move the cursor to the "Range" setting and select "AUTO."
- Initial set up using the 8901 Modulation Analyzer:
  - Press the FM MEASUREMENT button. (The "Error 03-input level too low" indication is normal until an input signal is applied.)
  - Simultaneously press the Peak - and Peak + buttons. Both LEDs on the buttons should light.
  - Press the 15 kHz LP filter key.

1. Select **TX Deviation Balance (Compensation)** from the Tuner Main Menu. The screen will indicate the transmit frequencies to be used.

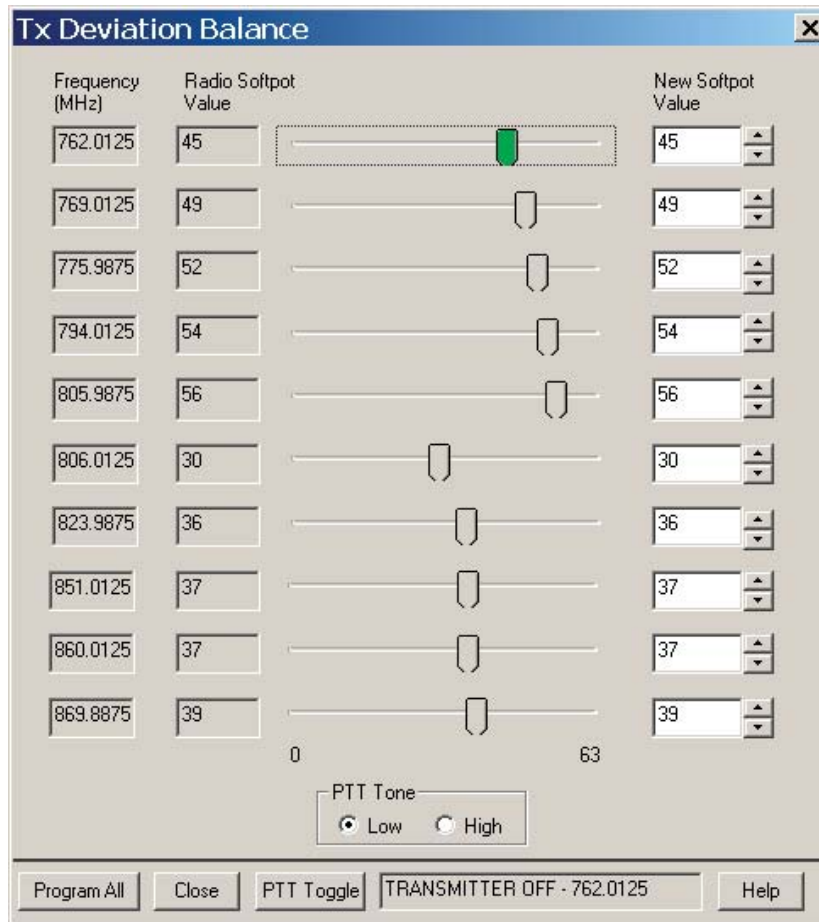


Figure 6-11. Tx Deviation Balance (Compensation) Alignment Screen

2. Left-click the highest frequency field first.
3. Left-click the **PTT Tone Low** button.
4. Left-click the **PTT Toggle** button on the screen to enable transmission. The screen indicates whether the radio is transmitting. Wait approximately 5 seconds until the voltage shown on R-2670, or the deviation shown on the 8901 Analyzer, stabilizes.
5. Measure and record the AC voltage value from the R-2670 Analyzer or the deviation value from the 8901 Analyzer.
6. Left-click the **PTT Tone High** button.
7. Adjust the softpot value until the measured deviation/voltage, when using the high tone, is within  $\pm 1.5\%$  of the value observed when using the low tone.
8. Repeat steps 3-7 for the remaining frequencies.
9. Left-click the **Program All** button on the screen to dekey the radio and save the tuned values.
10. Left-click the **Close** button on the screen to return to the Tuner Main Menu.

### 6.4.9 Tx Deviation Limit

**NOTE:** This alignment is required after replacing (or servicing) components on the transceiver board.

The Tx Deviation Limit alignment procedure limits the modulation of a baseband signal. It is used for primary modulation limiting. This procedure needs to be performed at multiple frequencies to allow for proper alignment across the entire RF band. The RF band is divided into frequency zones with a calibration point (value) in each zone.

This test can be done with either the R-2670 Communication Analyzer or the Agilent 8901 Modulation Analyzer. The method of choice is the R-2670 Analyzer.

- Initial set up using the R-2670 Communication Analyzer:
    - Connect a BNC cable between the "DEMOD OUT" port and the "VERT/SINAD DIST/DMM COUNTER IN" port on the R-2670.
    - Press the SPF key on the R-2670 to display the "SPECIAL FUNCTIONS MENU." Move the cursor to "High Pass," and select 5 Hz on the soft key menu. Select 20 kHz for the "Low Pass" setting.
    - In the "RF Control" section of the R-2670, enter the frequency displayed on the tuner screen. Move the cursor to the "B/W" setting and select "WIDE  $\pm 100$  kHz" on the soft key menu.
    - Place the R-2670 cursor in the "Display" zone. Select "AC VOLTS" on the soft key menu.
    - Move the cursor to the "Range" setting and select "AUTO."
  - Initial set up using the 8901 Modulation Analyzer:
    - Press the FM MEASUREMENT button. (The "Error 03-input level too low" indication is normal until an input signal is applied.)
    - Simultaneously press the Peak - and Peak + buttons. Both LEDs on the buttons should light.
    - Press the 15 kHz LP filter key.
1. Select **TX Deviation Limit** from the Tuner Main Menu. The screen will indicate the transmit frequencies to be used. See [Figure 6-12 on page 6-15](#).



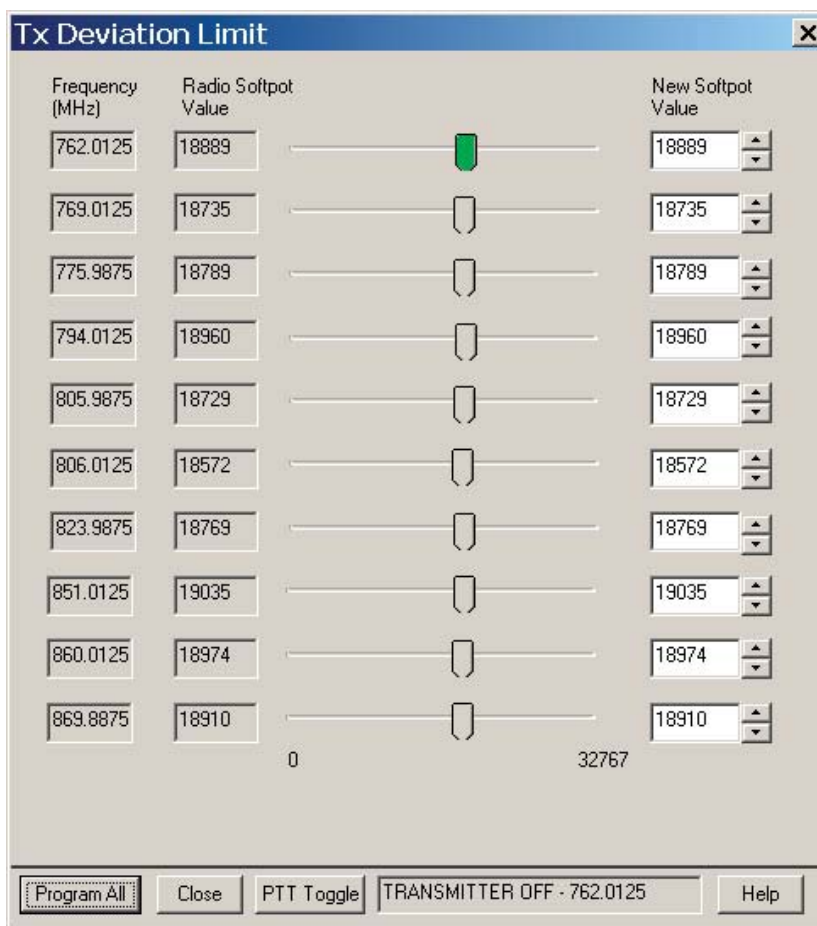


Figure 6-12. Tx Deviation Limit Alignment Screen

2. Left-click the highest frequency field first.
3. Left-click the **PTT Toggle** button on the screen to make the radio transmit. Wait approximately 5 seconds until the deviation/voltage displayed on the analyzer stabilizes. The screen indicates whether the radio is transmitting.
4. Adjust the deviation limit between 0.158 and 0.163 Vac on the R-2670 (2.785 to 2.885 kHz). The optimum setting is 0.160 Vac (2.83 kHz).
5. Repeat steps 3-5 for the remaining frequencies.
6. Left-click the **Program All** button on the screen to dekey the radio and save the tuned values.
7. Left-click the **Close** button on the screen to return to the Tuner Main Menu.

## 6.5 Performance Testing

### 6.5.1 Bit Error Rate (BER) Test

This procedure tests the Bit Error Rate (BER) of the radio's receiver at a desired frequency and contains the fields described in [Table 6-16](#).

Figure 6-13. Bit Error Rate Screen

Table 6-16. Bit Error Rate Test Fields

Field	Description
Rx Frequency	Selects the Receive Frequency in MHz.
Test Pattern	Selects the Digital test pattern - TIA. Choices are: <b>Standard Tone Test Pattern</b> (framed 1011) and <b>Standard Interface Test Pattern</b> (CCITT V.52).
Modulation Type	Selects the digital modulation type of the incoming signal on which BER is to be calculated.
Continuous Operation	<p>Allows the user to adjust the number of test repetitions. A selection of <b>Yes</b> will cause the radio to calculate BER on a continuous basis indefinitely and update the results on this screen after each integration time. A selection of <b>No</b> will cause the BER test to execute only one sample and then update the display.</p> <p><b>NOTE:</b> When Continuous Operation = Yes, all fields will be grayed out while the test is in progress. They will be enabled when the test is complete, or if the STOP button is pressed.</p> <p>When Continuous Operation = No, a wait cursor will be displayed while the test is in progress and return to normal when the test is done.</p>

Table 6-16. Bit Error Rate Test Fields (Continued)

Field	Description
Audio	Allows the user to select the audio output during a test. Selecting <b>External</b> will route the same signal to the radio's accessory connector audio output. Selecting <b>Internal</b> is not supported. Selecting <b>Mute</b> will disable the audio output.
BER Integration Time	Represents the amount of time during which the Bit Error Rate is to be calculated. Remember that integration over a longer time period results in a more precise measurement, at the expense of more time per measurement.  <b>NOTE:</b> This is especially useful in fading measurements.  The range is from 0.360 to 91.8 seconds in increments of 0.360 seconds.

### 6.5.2 Transmitter Test Pattern

This procedure allows you to generate test patterns at selectable frequencies and channel spacing to check the transmitter. The procedure contains the fields described in [Table 6-17](#):

Table 6-17. Transmitter Test Pattern Fields

Field	Description
Tx Frequency	This field selects the Transmit Frequency directly in MHz.
Channel Spacing	This field allows the user to select the desired transmit deviation in kHz.
Test Pattern Type	This field represents the type of test pattern which will be transmitted by the radio when the PTT Toggle button is pressed.

**NOTE:** Channel Spacing and Test Pattern Type fields will be grayed out while radio is transmitting.

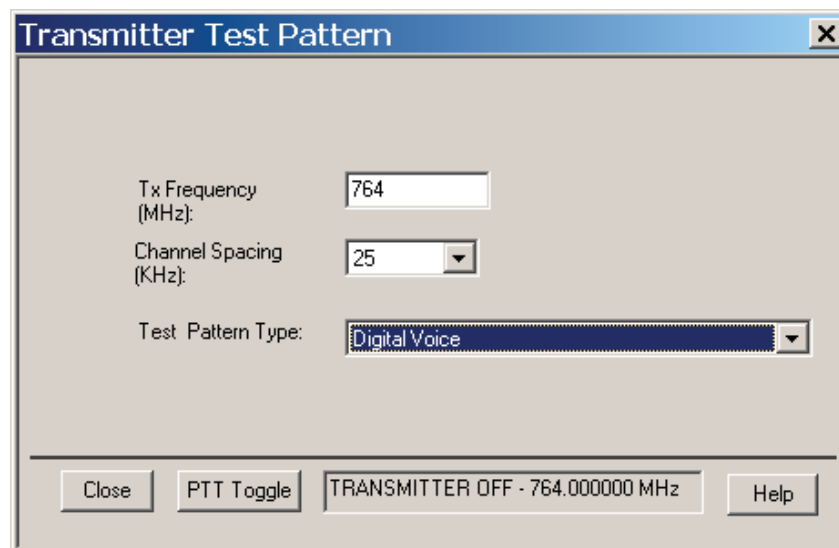
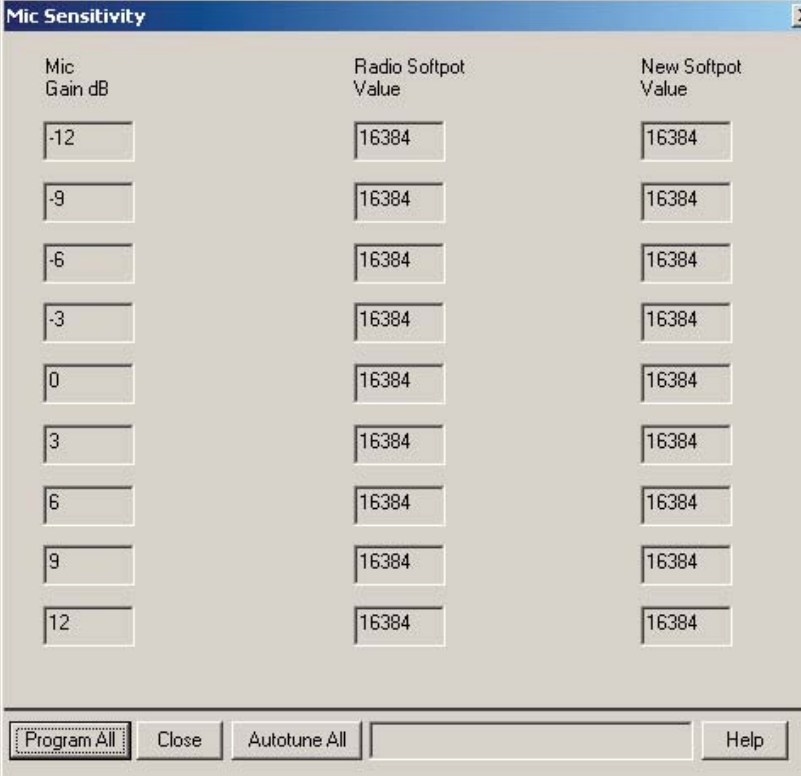


Figure 6-14. Transmitter Test Pattern Screen

## 6.6 Mic Sensitivity Calibration

This procedure allows you to calibrate the microphone sensitivity level at each CPS setting (-12, -9, ..., +9, +12), eliminating tolerances and deviations in the microphone hardware lineup circuitry. By tuning each CPS setting, the microphone sensitivity will be adjusted to exactly 3 dB difference between every 2 consecutive settings throughout the programmable range of the circuit. The **Autotune All** button will calibrate all nine settings in one adjustment.



The screenshot shows a software window titled "Mic Sensitivity" with a table of calibration data. The table has three columns: "Mic Gain dB", "Radio Softpot Value", and "New Softpot Value". Each cell contains a numerical value. At the bottom of the window, there are four buttons: "Program All", "Close", "Autotune All", and "Help".

Mic Gain dB	Radio Softpot Value	New Softpot Value
-12	16384	16384
-9	16384	16384
-6	16384	16384
-3	16384	16384
0	16384	16384
3	16384	16384
6	16384	16384
9	16384	16384
12	16384	16384

Figure 6-15. Mic Sensitivity Calibration Screen

---

# Chapter 7 Encryption

## 7.1 Universal Crypto Module Kits

**NOTE:** This information applies to both conventional and trunked systems.

The encryption modules use a custom encryption IC and an encryption key variable to perform their encode/decode functions. The encryption key variable is loaded into the encryption module using a key variable loader (KVL). The encryption IC corresponds to the particular encryption algorithm purchased.

Table 7-1 contains the Universal Crypto Module (UCM) kits and their corresponding algorithms for secure-equipped XTL 5000 radios.

Table 7-1. UCM Kit Listing

Kit Number	Description
NNTN4006	DES, DES-XL, DES-OFB ENCRYPTION KIT-UCM
NTN9837	DES, DES-XL, DES-OFB WITH DVP-XL ENCRYPTION KIT-UCM
NTN9838	DVI-XL ENCRYPTION KIT-UCM
NTN9839	DVP-XL ENCRYPTION KIT-UCM

### 7.1.1 Secure Interface Boards

Table 7-2 contains the secure interface board kits, which are used in conjunction with the UCM kits. Every secure-equipped radio must contain one of the two secure interface board kits, which is paired with one of the UCM kits.

Table 7-2. Secure Interface Board Kits

Kit Number	Description
HLN6876	Secure Interface Board, 3-day key retention
HLN6877	Secure Interface Board, 30-second key retention

### 7.1.2 Secure Dispatch Operation

For personalities or talkgroups that are programmed to be secure-selectable, press and release the *Secure* button to toggle between Secure and Clear.

- An illuminated secure status annunciator indicates that the transmitted signal will be encrypted when the **PTT** button is pressed.
  - The absence of the secure status annunciator indicates that the transmitted signal will not be encrypted.
-

Whether the current personality is strapped for secure or clear, the secure status annunciator correctly displays the transmit operation as being either secure (encrypted) or clear (non-encrypted).

**NOTE:** You cannot change from secure to clear while the **PTT** button is pressed. The radio will generate an illegal tone and the transmission will be terminated.

Secure-equipped radios automatically determine whether a secure or clear voice message is being received. This allows you to receive either type of message without having to reset the programmable secure button.

### 7.1.3 Secure Emergency Operation

Clear or Secure emergency-call operation is determined by the programming of the selected mode (or talkgroup) or the default emergency mode, if set up. Otherwise, transmit operation is controlled by the setting of the secure, programmable button. You will not be able to change from Secure to Clear, or from Clear to Secure, operation during an emergency call.

## 7.2 Load an Encryption Key

### 7.2.1 W3 Control Head

To load an encryption key into a W3 control-head equipped radio:

1. Ensure that an encryption module is installed in the radio.
2. Load an encryption key into the radio's memory from a key-variable loader (KVL) using the correct loader for the radio's encryption type.

To load the key, attach the keyloader cable to the front of the radio. (Refer to the KVL instruction manual for loading.)

3. **KEYLOADING** is displayed on your radio while the key transfer is in progress.



For single-key radios, a short tone sounds when a key is successfully loaded.

For multikey radios, an alternating tone sounds for a few seconds after keys are successfully loaded.

**NOTE:** An invalid encryption key aborts a secure transmission. **KEYFAIL** is displayed and a keyfail tone (consecutive medium-pitched beeps) sounds until you release the **PTT** button.

4. If a mode is not programmed for either secure or clear-only operation, use the secure programmable button to select secure or clear transmission.

**NOTE:** You cannot change from secure to clear, or from clear to secure, while pressing the **PTT** button.

## 7.2.2 W4, W5, W7, and W9 Control Heads

To load an encryption key into a W4, W5, W7, or W9 control-head equipped radio:

1. Turn on the radio and set the volume level.

The position of the  button is not important.

2. Connect the cable from the key-variable loader (KVL) to the microphone connector on the radio.
3. Load an encryption key into the radio's memory from a KVL using the correct loader for the radio's encryption type.

Refer to your KVL user's manual for more information on keyloading.

## 7.3 Advanced Secure Operation

**NOTE:** The Advanced Secure feature is available only on radios that have been equipped by the factory to support it. The radio must also be equipped with an encryption module.

Advanced Secure incorporates the Multikey feature and a dual-encryption feature into the existing secure system. Multikey allows a radio to be equipped with multiple encryption keys. A default key is included and is associated with the current mode. The keys are strapped to a given mode or are operator-selectable and can be indexed into groups of keys called keysets. The keys are loaded using a manual keyloader.

In addition, your radio can support up to eight different encryption algorithms simultaneously.

### 7.3.1 Multikey Operation


The multikey feature can be used in both conventional and trunked applications.

- **Conventional Multikey** - The encryption keys can be selectively strapped, one per each channel. In addition, the programmable radio features include operator-selectable keys, operator-selectable indices, and operator-selectable key erasure. Encryption keys are loaded into the radio through a KVL.
- **Trunked Multikey** - If the radio is used for both conventional and trunked applications, the encryption keys have to be strapped for trunking on a talkgroup, or announcement group, basis. In addition, a different encryption key can be strapped to other features, such as Private Call, Dynamic Regrouping, Failsoft, Interconnect, System Wide, or Emergency Talkgroup.

## 7.4 Erase a Key

This feature allows you to select any one, or all, of the encryption keys to erase.

### 7.4.1 W3 Control Head

1. Press  to scroll to ERAS.





2. Press the  button below ERAS.

The last selected and stored key is displayed.



3. Do one of the following:

**NOTE:** ERASED alternates with the key name if you go to a key that has been erased.

Press  to scroll forward in the list; press  to scroll backward.

**OR**


With Direct Entry, press the numeric keys to jump to the desired encryption key.

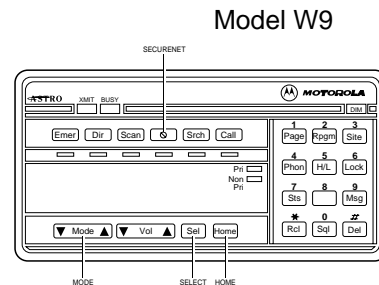
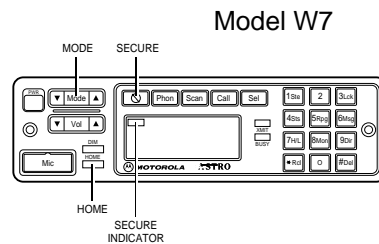
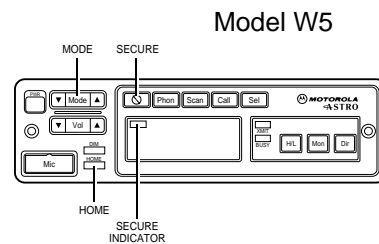
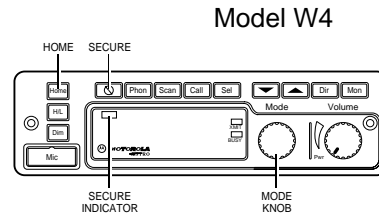
4. Go to [Section 7.5: "Erase a Single Key \(W3 Control Head\)"](#) on page 7-6.



## 7.4.2 W4, W5, W7, and W9 Control Heads

The *Select Key to Erase* feature allows you to manually select any one, or all, of the encryption keys to erase.

1. To enter the Advanced Secure menu, press and hold the  button until a tone sounds.



2. Turn the **Mode** knob (W4) or press the **Mode** rocker switch (W5, W7, W9) to scroll to the ERASE KEY option.
3. Press the **Set** button to enter the Key Erase menu.

The display changes to show the last key that was selected and stored after the Key Erase menu was entered.


4. Turn the **Mode** knob (W4) or press the **Mode** rocker switch (W5, W7, W9) to scroll to the desired key.
5. To delete the selected key, press the **Set** Button.

The radio deletes the key, and the display alternates between the key name and ERASED.

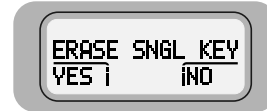
**NOTE:** When you scroll to an erased key, the display alternates between the key name and ERASED.

## 7.5 Erase a Single Key (W3 Control Head)

To erase a single key:

1. Press the  button below **SNGL** to request erasure of the selected key.

ERASE SNGL KEY, YES and NO are displayed.





2. Press the button below **YES**.

The internal selected key is set to zero.

ERASED is alternately displayed with the key name confirming the erasure.




3. To exit the menu without erasing a key, press the  button below **ABRT**, or the **PTT** button, or the mode button, or .

The home mode is displayed.

## 7.6 Erase All Keys

### 7.6.1 W3 Control Head

To erase all keys at the same time:

1. Press the  button below **ALL** to request erasure of all keys.

ERASE ALL KEYS, YES and NO are displayed.




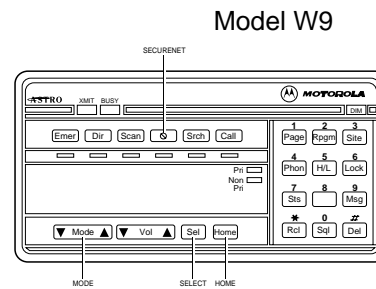
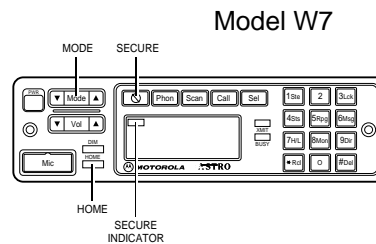
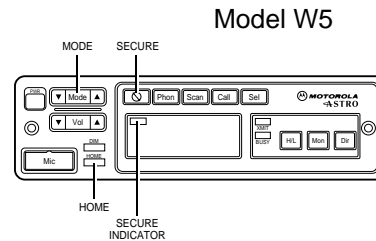
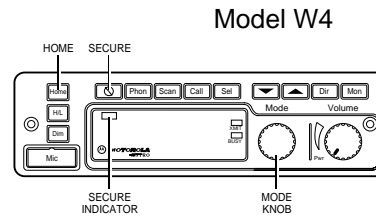
2. Press the button below **YES**. All keys are erased.

ERASED is alternately displayed with the key name confirming the erasure.



## 7.6.2 W4, W5, W7, and W9 Control Heads

1. To enter the Advanced Secure menu, press and hold the  button until a tone sounds.



2. Turn the **Mode** knob (W4) or press the **Mode** rocker switch (W5, W7, W9) to scroll to the **ALL** option.
3. Press the **Sel** button to erase all the keys in the radio.

The display shows **PLS WAIT** (W4, W5, W7) or **PLEASE WAIT** (W9) for two seconds, followed by **ERASED** being shown for about two seconds, then the display reverts back to **ALL**.


4. To abort from the key-erase menu, press the **HOME** button or the **PTT** button.

Pressing the **PTT** button causes the radio to transmit.

## 7.7 Over-the-Air Rekeying

The over-the-air rekeying (OTAR) feature allows the dispatcher to reprogram the encryption keys in the radio remotely.

### 7.7.1 W3 Control Head

1. Press  until REKY appears.



2. Press  below REKY.

REQUEST REKY is displayed.




3. Press the **PTT** button to send the rekey request.  
PLEASE WAIT is displayed.

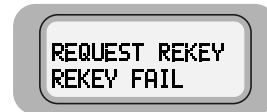
One of the following occurs:

The radio sounds five tones when the dispatcher has received the request.



**NOTE:** Any subsequent pressing of the **PTT** button will exit the feature and allow you to transmit in the normal manner. Pressing  or the emergency button also exits the feature.

If the display momentarily shows REKEY FAIL and a bad-key tone sounds, the rekey operation failed because the radio does not contain the Unique Shadow Key (USK) or Unique Key Encryption Key (UKEK).



You have to load the USK into the radio using the KVL before the radio can be reprogrammed over the air.

**NOTE:** If you exit at this point, but stay on the current channel in the dispatch mode, the radio momentarily shows REKEYED or DENIED and sounds a tone indicating the status of the rekey request.

If the display shows NO ACK and a bad-key tone sounds, then the dispatcher has not acknowledged your request after the radio has tried five times to send it.



The radio then returns to the display message in step 2, allowing you to retry the request.


If the request is accepted and the radio is successfully rekeyed, the display momentarily shows REKEYED.

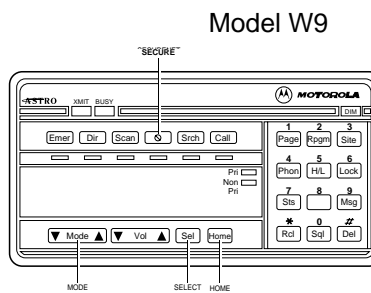
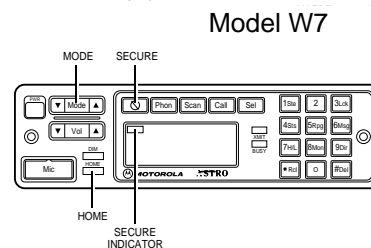
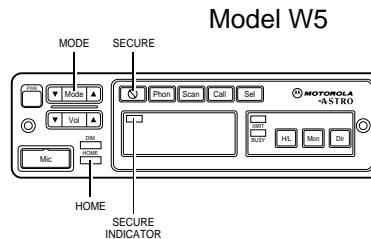
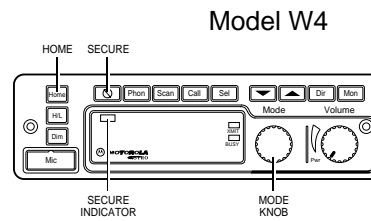


If the display momentarily shows DENIED and a bad-key tone sounds, the request has been denied by the dispatcher, and the radio returns to the home display.



## 7.7.2 W4, W5, W7, and W9 Control Heads

1. To enter the Advanced Secure menu, press and hold the  button until a tone sounds.



2. Do one of the following:
  - W4:** Using the **Mode** knob, scroll to the REKY option.
  - OR**
  - W5, W7, or W9:** Using the **Mode** rocker switch, scroll to the REKY REQ option.
3. To enter the rekey request menu, press and release the SEL button.
4. To initiate a rekey request, press and release either the **Sel** button or the **PTT** button.

The radio displays PLS WAIT (W4, W5, W7) or PLEASE WAIT (W9).

5. One of the following occurs:

If the radio receives an acknowledgment from the dispatcher, five tones sound.

If the radio does not receive an acknowledgment from the dispatcher, the display shows `NO ACK`.

After the radio is rekeyed, it displays `REKEYED` and returns to dispatch mode.

If the dispatcher does not allow it to be rekeyed, the radio displays `DENIED` and returns to dispatch mode after three seconds.


6. Press `HOME` to exit and return to normal operation.

---

# Chapter 8 Disassembly/Reassembly Procedures

## 8.1 Introduction

This section details the procedures necessary to remove and replace the printed circuit board in the ASTRO XTL 5000 radio. After troubleshooting and determining what needs to be replaced, disconnect the test equipment, the antenna cable, and the power cable.


 <b>WARNING</b>	<b>Disconnect the power cable from the radio before opening and removing the PCB. Failure to remove power can result in unit damage caused by transients or accidental shorts, as well as presenting a shock hazard.</b>
---	--

Locate the exploded view of the radio in [Chapter 11. Exploded Views and Parts Lists](#). Keep it handy for reference as you disassemble and reassemble the radio.

When installing a new circuit board, all mounting screws should be started before any are torqued. This will help ensure proper alignment.

After installing a new board, perform a complete alignment procedure as outlined in [Chapter 6. Radio Alignment Procedures](#).

## 8.2 Replacement Procedures

 <b>Caution</b>	After performing alignment procedures, always exit the SERVICE menu entirely (to the MAIN MENU) to properly save all changes. Failure to do so can result in an alignment, or other, failure.
---	---

### 8.2.1 Required Tools and Supplies

Table 8-1. Required Tools and Supplies

Tools and Supplies	Motorola Part Number
2.5 mm hex-key bit	
Anti-static grounding kit	0180386A82
Chassis eliminator	8180384N71
Control-head button extraction tool	6685629A01
Control-head interconnect service cable	
Dismantling tool	6686119B01
Electromagnetic Interference (EMI) metallic shielding tape, or equivalent	1185984D01
Flat-blade screwdriver	

---

Table 8-1. Required Tools and Supplies (Continued)

Tools and Supplies	Motorola Part Number
Magnetic screwdriver set with bits	0180320B16
Mini-UHF to N-type adapter cable	3085651A01
Plastic scraping tool	6686119B01
Removal and insertion tool	6680163F01
Roto-Torq adjustable driver	RSX4043
Small, flat-blade screwdriver	
Solder aid (black stick), Hexacon Electric Co.	MA-800G
Torx® T10 and T20 drivers	

## 8.2.2 Control Head Boards Disassembly/Reassembly

### 8.2.2.1 W3 Disassembly

**NOTE:** Bracketed numbers are identical to item numbers shown in [Figure 11-1. "W3 Hand-Held Control Head Exploded View" on page 11-2.](#)

1. Remove the strain-relief boot covering the control-head cable connector [15] from the housing assembly [7] by pulling it away from the control head until they are completely separated.
2. Carefully remove the rubber seal (part of cable assembly [15]) from the housing assembly [7] opening.

**NOTE:** Take care to avoid damaging this seal.

3. Using a small screwdriver, remove the seal support wedge [14] from the control head.
4. Using a small screwdriver to depress the telco lever, remove the telco connector at the end of the cable assembly [15] from the control head, and pull the cable assembly away from the housing (like a telephone jack).
5. Remove the rear cover assembly [2] from the control head.

Locate the recesses in the lower portion of the housing on both sides of the rear cover's snap features and, prying the snaps until the two parts separate, remove the rear cover from the unit.

6. Remove the two snap retainers [4] from between the SB9600 circuit board [5] and the housing assembly [7].
7. Disconnect the microphone assembly [8] connector from the SB9600 circuit board [5].
8. Carefully remove the microphone assembly [8] from the keypad [6].

**NOTE:** Be careful to avoid damaging circuit-board components in the next step.

9. There are seven snaps locking the circuit board to the housing. Carefully pry the housing's snap features from the SB9600 circuit board [5]. As the snap features are deflected, push the circuit board upward, using the keypad, to release the circuit board from the snap features.
10. Remove the circuit board assembly from the housing assembly [7].
11. Remove the keypad [6] from the housing assembly [7].



12. Remove the PTT boot [12] and the PTT lever [10] from the housing assembly [7].
13. Remove the PTT actuator [9] from the housing assembly [7].
14. If damaged, remove the nameplate label [13] from the front of the housing assembly [7].
15. Remove the transmit indicator [11] from the housing assembly [7].

### 8.2.2.2 W3 Reassembly

**NOTE:** Bracketed numbers are identical to item numbers in [Figure 11-1. "W3 Hand-Held Control Head Exploded View" on page 11-2.](#)

1. Insert the transmit indicator [11] into the housing assembly [7]. Ensure that the top surface of the lightpipe is below the label recess of the housing.
2. Attach the nameplate label [13] to the front of the housing assembly [7]. Ensure that the label is securely attached.
3. Install the PTT actuator [9] into the housing assembly [7]. Ensure that its lip is seated in the groove in the housing.
4. Install the PTT lever [10] and the PTT boot [12] into the housing assembly [7]. Ensure that the lever is seated in its nest and the boot is located properly in the recesses in the housing.
5. Install the keypad [6] into the housing assembly [7]. Ensure that all of the keys are located in the correct openings in the housing.
6. Install the microphone assembly [8] into the keypad. Ensure that the front surface of the cartridge is located up against the keypad membrane.

**NOTE:** The membrane is the rain seal and is very sensitive to puncture by sharp objects.

7. Connect the microphone assembly [8] connector to the mating location on the SB9600 circuit board [5].
8. Install the circuit board [5] into the housing assembly [7] as follows:
  - a. Hold the housing assembly so that its key openings face downward and its top faces away from you.
  - b. Insert the circuit board's display down under the housing retention features, and rotate the board downward, ensuring that the board is positioned between the snap features. Ensure that the microphone assembly's [8] wire passes through the opening in the circuit board.
  - c. Press downward firmly on the board until the seven snap features lock the board into place.
9. Install the two snap retainers [4] between the circuit board and the side wall of the housing assembly [7], one on each side.
10. Install the main seal [3] onto the rear cover assembly [2], placing the seal under the retainer features around the perimeter of the cover.
11. Install the rear cover assembly [2] onto the housing assembly [7]. Starting at the top of the cover, pivot the cover toward the housing and squeeze the two halves together until the snap features at the lower end of the rear cover engage the housing's features and snap closed.
12. Insert the cable assembly's [15] telco connector into the opening in the bottom of the housing, ensuring that it correctly is oriented.
13. Press the telco connector in place until it snaps in (like a phone plug).
14. Place the seal support wedge [14] into the housing's opening, orientating it so that its long portion is under the telco connector lever, and then push until it is properly seated.

15. Push the rubber seal (part of the cable assembly [15]) into the housing's opening and ensure that it is properly seated.

**NOTE:** This seal must be inserted completely into the housing to ensure the rain seal.

16. Push the strain relief boot (part of the cable assembly [15]) into the housing, and ensure that it is properly seated.
17. Insert the kit label [1] into the recess on the rear cover, ensuring that it is securely attached.

### 8.2.2.3 W4, W5, and W7 Disassembly

**NOTE:** For the following procedure, refer to [Chapter 11. Exploded Views and Parts Lists](#), beginning on [page 11-1](#), for the exploded view and associated parts list applicable to the model being disassembled.

1. Unplug the microphone.
2. Remove the two front panel screws using a 2.5 mm hex-key driver.
3. Disconnect the control cable on remote models.
4. Grasp the front panel firmly, and carefully unplug the control head assembly from the radio or remote control head back housing. For dash-mount models, unplug the interconnect flex cable from the control head.
5. Lay the control head face down on a clean, flat surface, being careful not to scratch or mar the display.
6. Using a Torx T10 driver, remove the control head screws:
  - W4 control head: four screws [callouts 5-8], as shown in [Figure 8-1 on page 8-4](#).

The W4 control head has, in addition to the screws, four snap features [callouts 1-4], which are shown in [Figure 8-1 on page 8-4](#).

- W5 and W7 control heads: seven screws, as shown in [Figure 8-2 on page 8-5](#).

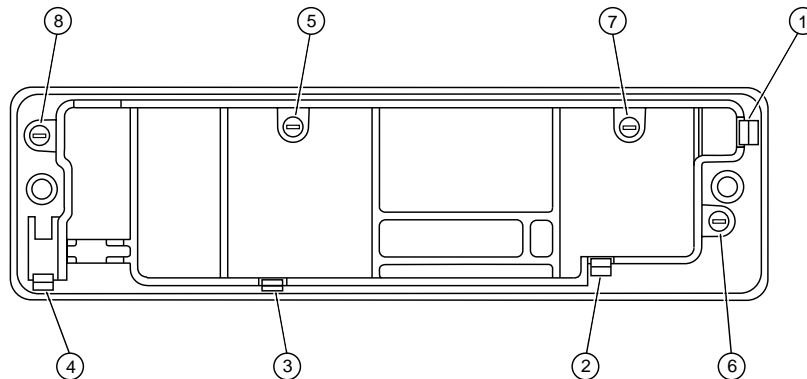


Figure 8-1. W4 Rotary Control-Head Assembly Screw and Snap Sequence

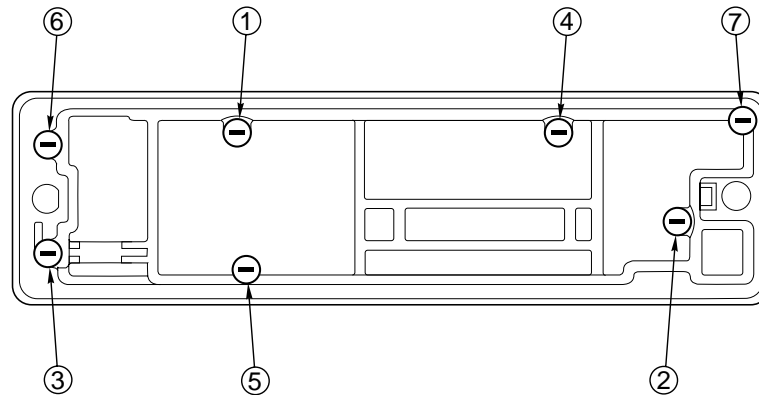


Figure 8-2. W5 and W7 Pushbutton Control-Head Assembly Screw Sequence

7. Carefully separate the printed circuit board, internal spacer, and elastomer keypad assembly from the front panel.

On rotary control-head models, care must be taken not to damage the flex circuit when separating the printed circuit board from the front housing. Do not disturb the buttons in the front panel.

On rotary control-head models, the flex circuit must also be unplugged.

8. On rotary control-head models, desolder the XMIT and BUSY LED before removing the elastomer keypad.
9. Remove the elastomer keypad from the printed circuit board.

**NOTE:** Before you unsnap the PC board, notice that the board slips under a hook on the right and snaps on the left. This will facilitate assembly.

10. Remove the PC board from the internal spacer. The PC board snaps into and out of the spacer.

#### 8.2.2.4 W4, W5, and W7 Reassembly

**NOTE:** For the following procedure, refer to [Chapter 11. Exploded Views and Parts Lists](#), beginning on [page 11-1](#), for the exploded view and associated parts list applicable to the model being reassembled.

1. To reassemble, snap the PC board into the internal spacer. Before you press the elastomer keypad into the board, make sure that the conductive pads in the board and the elastomer keypad are clean and free of any foreign material.
2. On rotary control-head models, solder the XMIT and Busy LEDs onto the PC board.

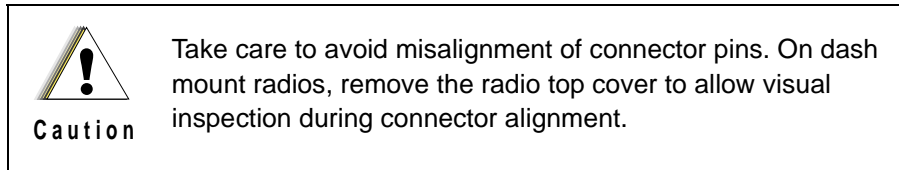
**NOTE:** On rotary control-head models, the flex circuit must be connected to the PC board prior to attaching the PC board to the spacer.

3. Install the PC board internal spacer and elastomer keypad assembly into the front panel. Replace the screws and torque them to 6-8 in.-lbs.



**Caution**

When reassembling the control head, make sure the microphone pins are properly inserted through the elastomeric keypad. Also make sure the elastomeric keypad inserts are secured to the PC board.



4. For dash-mounted radios, plug the interconnect flex from the radio into the control head, slide the control head into the headbridge, and fasten the control head with the two front panel screws (torqued to 6-8 in.-lbs).

**OR**

For remote-mount control heads, replace the front panel into the remote control head back housing, make sure the gasket is in place, then torque the screws to 6-8 in.-lbs. Replace any plugs and cables on the rear of the control head.

### 8.2.2.5 W9 Disassembly

**NOTE:** Bracketed numbers are identical to item numbers in [Figure 11-4. "W9 Pushbutton Control Head Exploded View" on page 11-5.](#)

**NOTE:** Before disassembling the W9 control head, note the location of the labeled bottom.

1. Using a Torx T15 driver, remove the two 30mm machine screws [29] from the back housing [31] of the control head.
2. Fold the front housing [41] over so that the front housing is face down and the back housing is on your working surface with the flex cable [18] attached.
3. Using a Torx T10 driver, remove the five 8mm tapping screws [17] from the Display Board Kit [37], the two 10mm captive screws [12] with the leaf assembly spring [11], and the two 16mm tapping screws [38] from the control PC board.
4. Remove the Command Board Kit [36] from the back housing and the Display Board Kit [37] from the front housing.
5. Remove the elastomer keypad [7], ON/OFF switch gasket [34], the "D" Connector Gasket [33], the solder side shield [16], and the component side shield [19] from the PC boards.

**NOTE:** Be careful to not bend the tabs on the shields when removing them and align them carefully when replacing the shields. When working with chips and SOT (small outline transistor) parts, use extreme caution when heating. Never reuse a chip or SOT part; always replace with the correct Motorola part.

### 8.2.2.6 W9 Reassembly

**NOTE:** Bracketed numbers are identical to item numbers in [Figure 11-4. "W9 Pushbutton Control Head Exploded View" on page 11-5.](#)

1. Install the new PC board with the elastomer keypad, the ON/OFF switch gasket, the "D" Connector Gasket, the "D" Connector O-ring, the solder-side shield, and the component-side shield in the appropriate locations.
2. Reassemble the Command Board Kit [36] into the back housing [31], making sure that the power switch is in the proper location and replace the two tapping screws [38], torquing them to 6-8 in.-lbs.
3. Reassemble the Display Board Kit [37] into the front housing [41], making sure that the elastomer keypad [7] is in the proper location.

4. Replace the captive screws [12] and the leaf assembly spring [11] in the front housing, and torque them to 6-8 in.-lbs.

**NOTE:** Before assembling the leaf assembly spring, check that the insulator [10] on the board is present. Ensure that the leaf assembly spring and captive screws are aligned properly to prevent stripping the front housing screw bosses.

5. Close the assembly by replacing the front housing [41] and the two screws in the back housing [31]. Torque the screws to 6-8 in.-lbs.

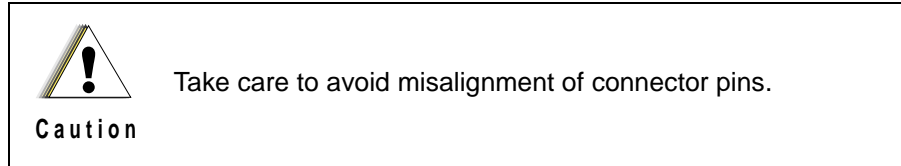
### 8.2.3 Remote Back Housing Interface Board Disassembly/Reassembly

#### 8.2.3.1 W4, W5, and W7 Disassembly

1. Unplug the microphone.
2. Disconnect the control cable from the control head on remote models.
3. Remove the two front panel screws using a 2.5 mm hex-key driver.
4. Grasp the front panel firmly, and carefully unplug the control head assembly from the radio or remote control head back housing.
5. Remove the two remote back housing interface attachment screws.
6. Remove the remote control head interface board from the remote control head back housing.

#### 8.2.3.2 W4, W5, and W7 Reassembly

1. Attach the new interface PC board to the back housing with two screws torqued to 6-8 in.-lbs.

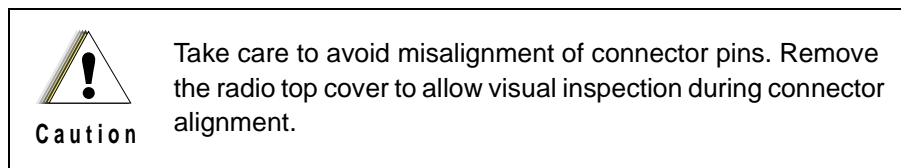


2. Reassemble the back housing to the front housing with two screws torqued to 4-6 in.-lbs.

### 8.2.4 Remote Interconnect Board Assembly/Reassembly

#### 8.2.4.1 Assembly

1. Remove the two front panel screws using a 2.5 mm hex key driver.
2. Grasp the front panel firmly, and carefully unplug it from the radio.
3. Remove the three screws that hold the remote interconnect board to the front panel using a Torx T10 driver.
4. Install the new remote interconnect board onto the front panel, and replace the screws. Torque the screws to 6-8 in.-lbs.



### 8.2.4.2 Reassembly

1. Reconnect the interconnect flex to the radio, noting proper alignment of the mating connections.
2. Reassemble the front panel into the radio and replace the screws.
3. Torque the screws to 6-8 in.-lbs.

### 8.2.5 Radio Disassembly

Use the following procedure to disassemble your radio:

1. Ensure all accessory connections, power, antenna, and microphone are unplugged.

If the radio is a remote-mount radio, disconnect the remote-mount control cable from the front of the transceiver.

2. Remove the two front control-head screws using a 2.5 mm hex-key bit. Save them for later use.



Figure 8-3. Removing the Front Panel Screws

3. Firmly grasp the front panel of the control head, and carefully remove the control-head assembly from the radio. Be careful not to pull on the attached flex.



Figure 8-4. Removing the Control Head

4. Lay the control head face down on a clean, flat surface, being careful not to scratch or mar the face of the display.
5. Carefully disconnect the control-head flex from the control head or remote interconnect panel, and set the control head aside.

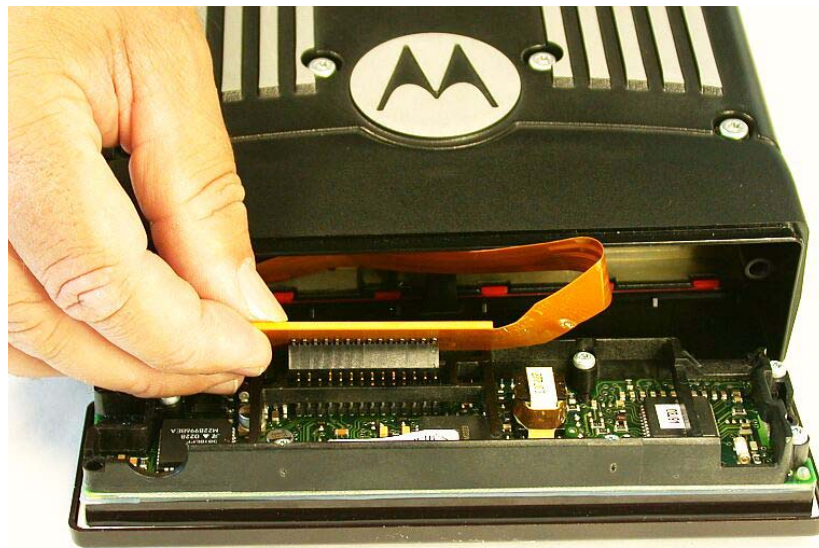


Figure 8-5. Removing the Flex (Control-Head Connector)

6. Remove the plastic headbridge by squeezing in the center of the top and bottom sides of the part and pulling away from the transceiver.

**NOTE:** Be careful to avoid pulling on the flex.



*Figure 8-6. Removing the Headbridge*

7. Carefully remove the control-head flex from the transceiver by grasping the provided handle and separating it from the connector.



*Figure 8-7. Removing the Flex (Main-Board Connector)*



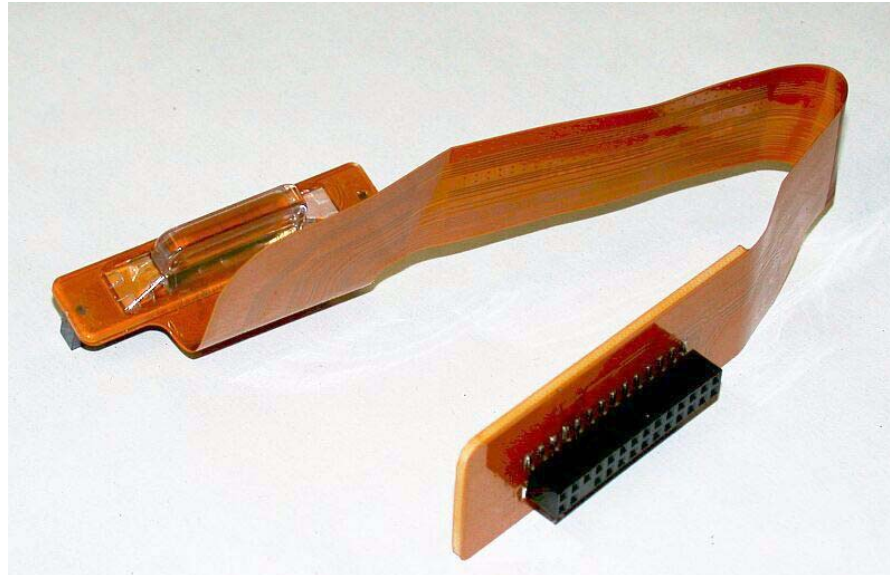


Figure 8-8. Control-Head Flex (Removed)

8. Remove the headbridge seal from the transceiver.

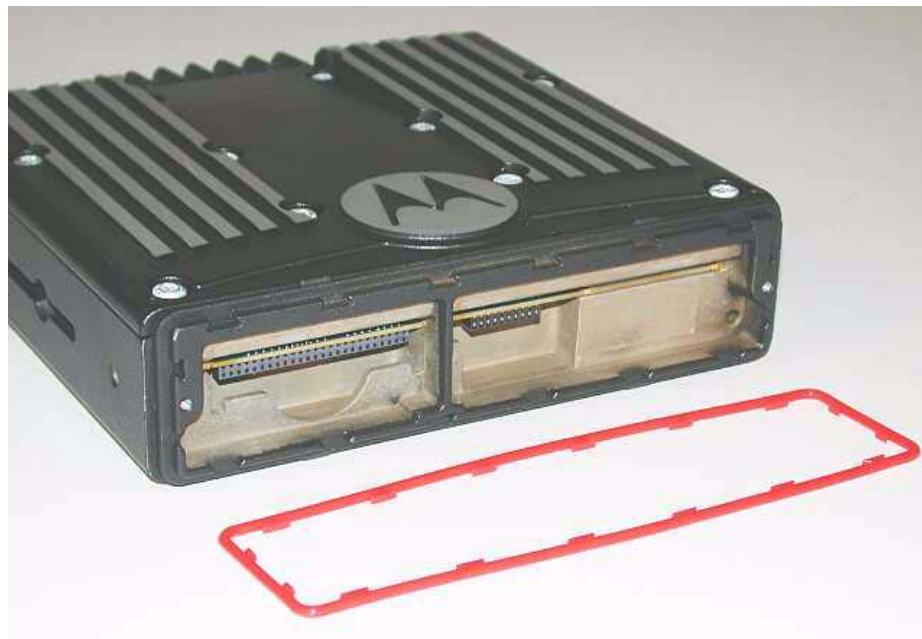


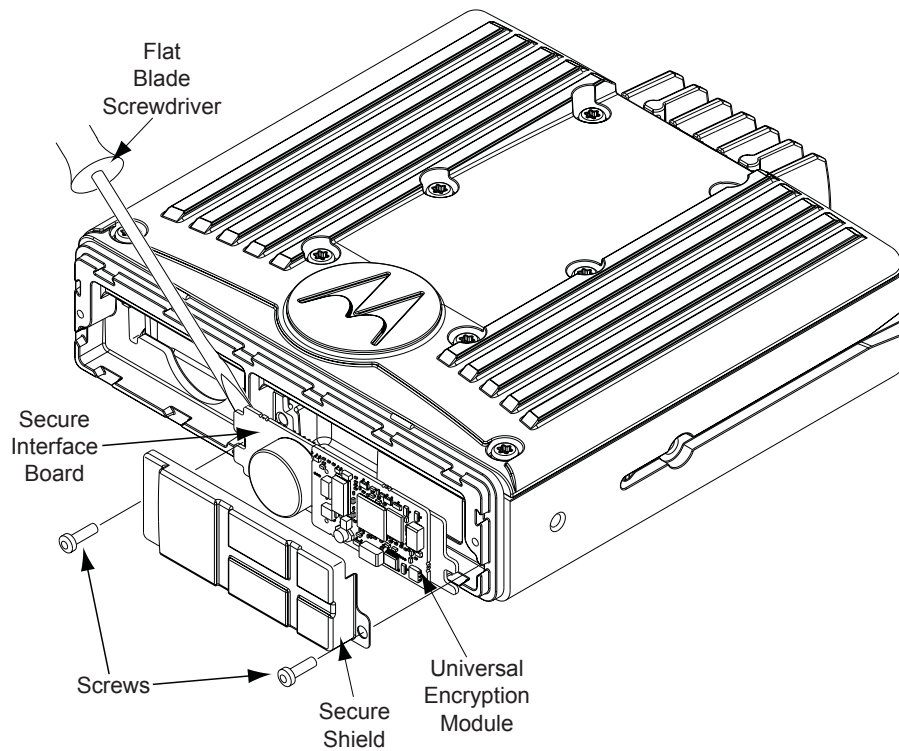
Figure 8-9. Headbridge Seal (Removed)



Caution

The following steps **MUST** be performed for secure-equipped radios prior to removal of the cover or damage to the radio could occur.

9. For secure option-equipped radios, do the following prior to disassembly of the transceiver:
  - a. Remove the two screws holding the secure (UCM) shield in place.
  - b. Pull the UCM shield away from the assembly and remove it.
  - c. Insert a flathead screwdriver into the space in the upper-left corner of the secure pocket, and gently pry the secure interface board (universal encryption module) away from the chassis.



MAEPF-27658-O

Figure 8-10. Removing the Secure Interface Board

10. Remove the 10 top-cover screws using a T20 Torx bit. These screws have sealing washers that should be kept with the screw.



*Figure 8-11. Removing the Top Cover Screws*

11. Remove the top cover by lifting up simultaneously on both side edges. It may be necessary to gently pry the cover off using a plastic tool.



*Figure 8-12. Lifting the Top Cover*

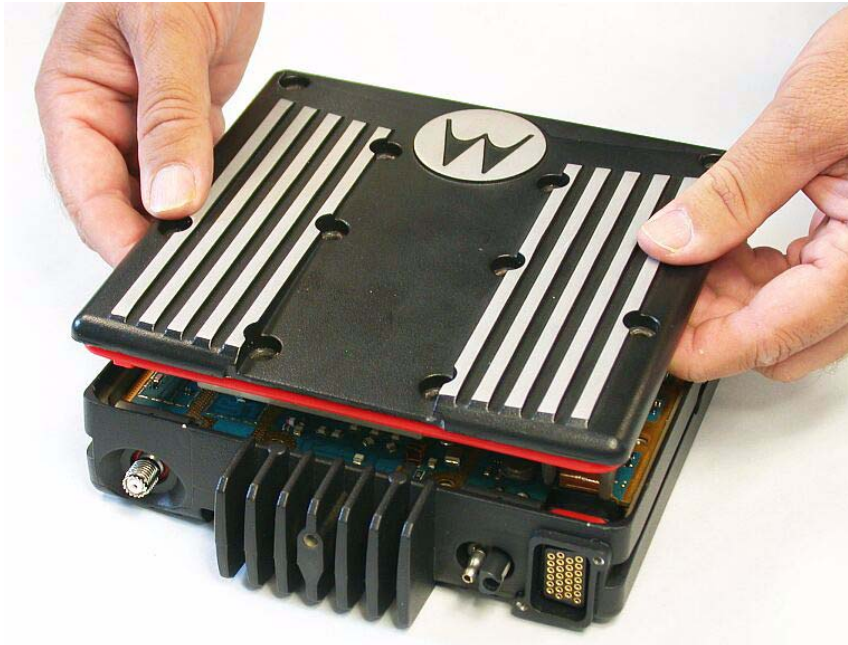


Figure 8-13. Removing the Top Cover

12. Disconnect the rear accessory jack's flex from the main board.



Figure 8-14. Removing the J2 Rear Accessory Flex from the Main Board



Caution

The PA screws must be removed BEFORE the RF/DC retention clips or damage may occur to the PCB.

13. : Remove the three PA screws using a T10 Torx bit.

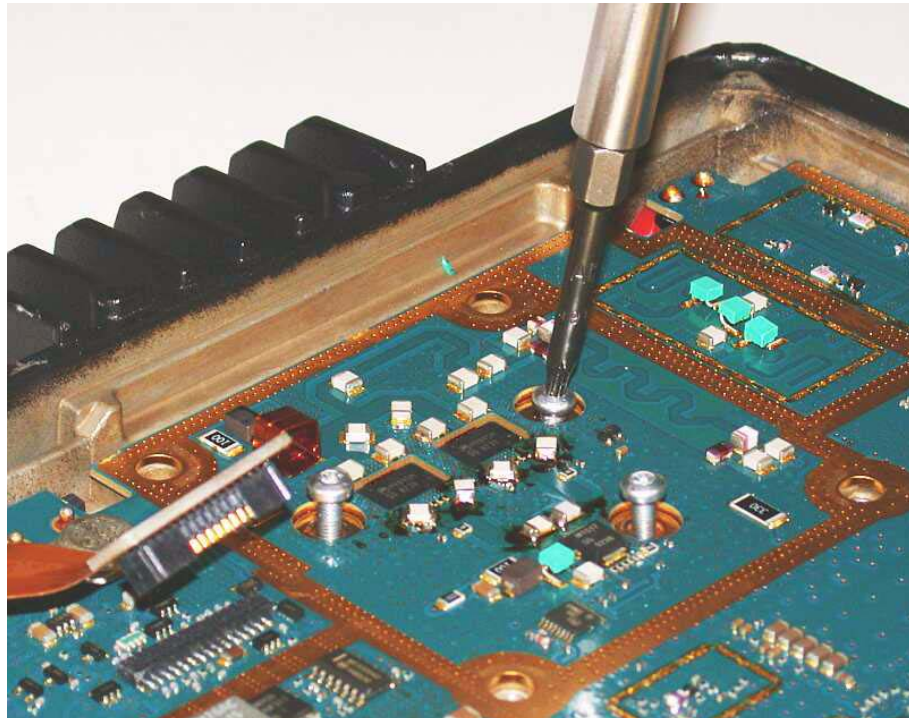
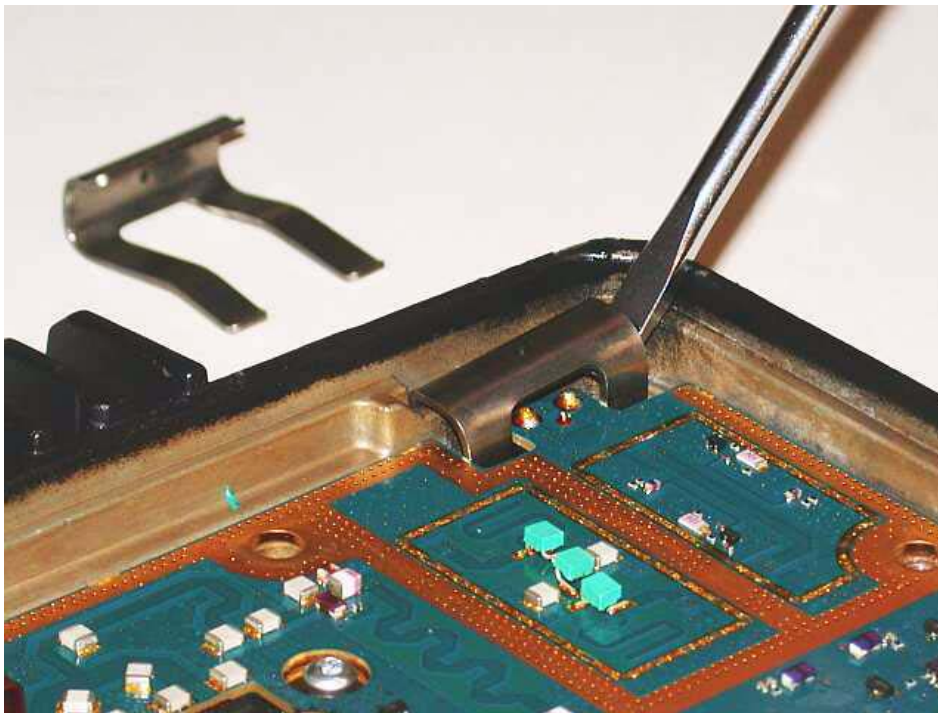


Figure 8-15. Removing the PA Screws

14. Remove the RF/DC retention clips by gently prying them out with a flathead screwdriver. For leverage, use only the slots provided immediately adjacent to the clips.

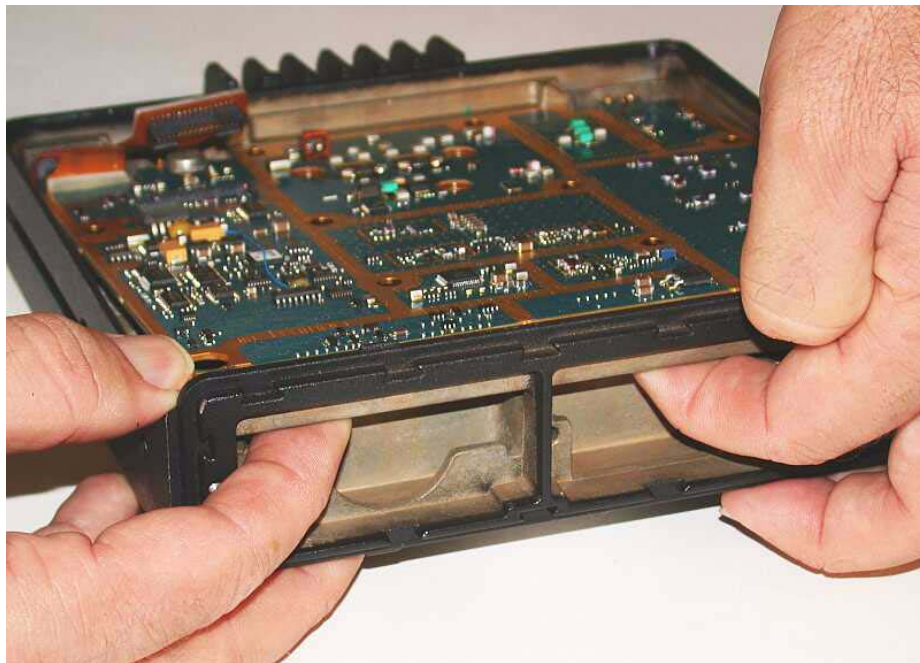


*Figure 8-16. Removing the RF/DC Retention Clip (J2 Connector Side)*



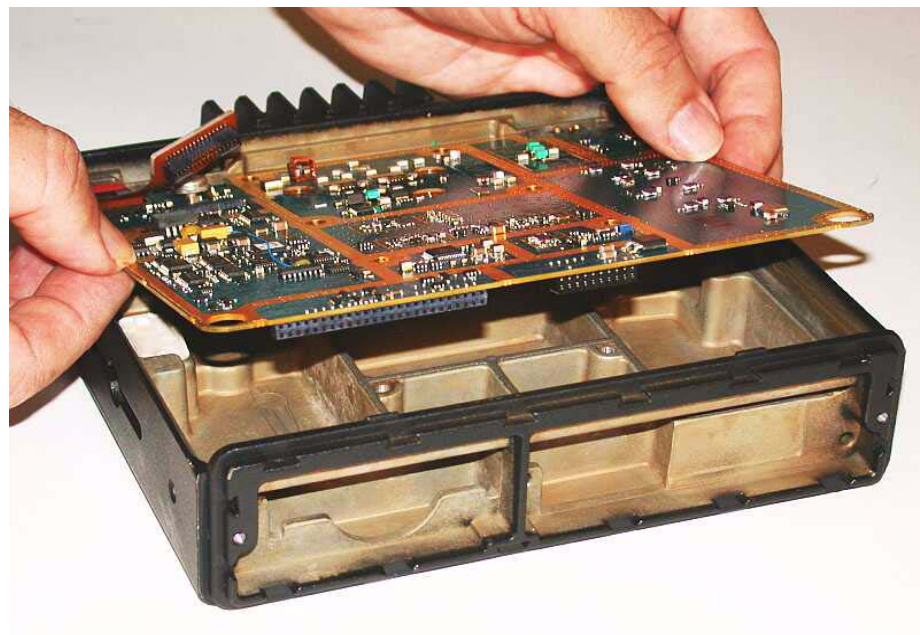
*Figure 8-17. Removing the RF/DC Retention Clip (Antenna Connector Side)*

15. Remove the main board by sliding a finger into the provided opening at the front of the chassis and gently pressing up on the 50-pin connector, lifting up the front of the PCB.



*Figure 8-18. Pushing Up the Main Board*

16. Then, slide the main board towards the front of the chassis and up and out. Handle the main board by the edges only, and store it in an antistatic bag.



*Figure 8-19. Lifting Out the Main Board*

17. Remove the J2 rear accessory connector by sliding it out of the chassis wall.



**Caution**

Do not attempt to remove the J2 accessory connector by pulling on the flex. Doing so might damage the flex.



*Figure 8-20. Removing the J2 Rear Accessory Connector*



## 8.2.6 Radio Reassembly

Use the procedure that follows to reassemble your radio.

1. Prior to reassembling the radio, inspect all seals and sealing surfaces for damage (nicks, cuts, etc.) or dirt. Refer to the exploded view bill of materials for the correct part numbers, and replace parts, as necessary. Reseat all seals on their respective parts.

Begin with the chassis. Thoroughly inspect the chassis shield gasketing for damage and verify all chassis thermal pads are in place and free of damage. See ["Chassis Thermal Pad Replacement Procedure"](#) on page 8-30 to replace damaged pads.

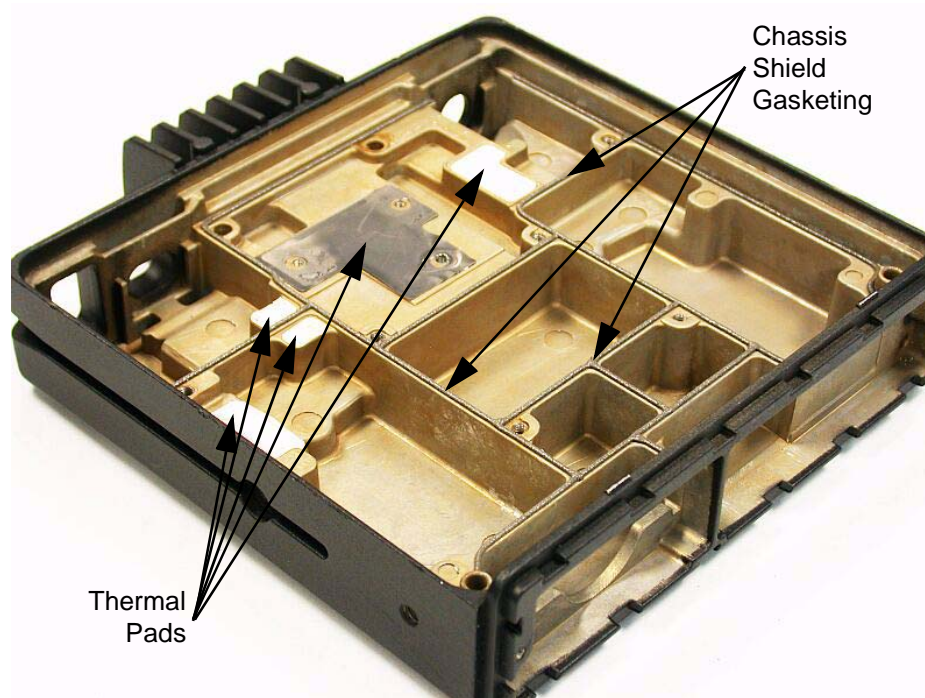


Figure 8-21. Inspecting the Chassis Shield Gasketing and Thermal Pads

2. After inspecting and seating the seal properly on the connector, insert the J2 rear accessory connector into the chassis and slide it into place.



**Caution**

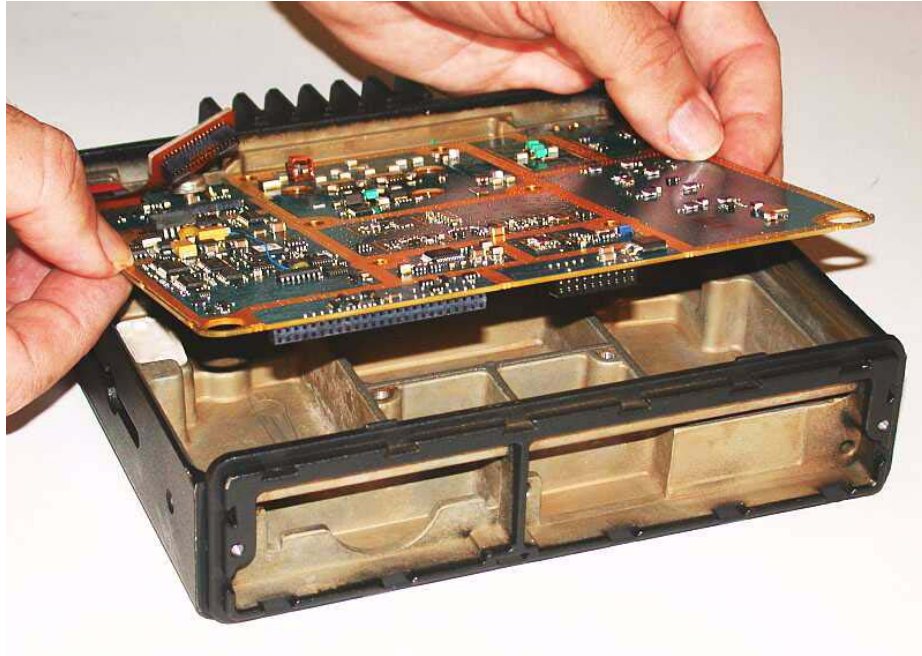
Do not attempt to insert the J2 accessory connector by holding onto the flex. Doing so might damage the flex.



*Figure 8-22. Inserting the J2 Rear Accessory Connector*

3. Tilt the main board and slide it into place, taking care to line up the RF and DC connectors with the holes in the back of the chassis. Push back and down on the front of the main board to fully seat it.

Ensure that the main board alignment holes are positioned over the chassis alignment bosses and that the main board is fully seated.



*Figure 8-23. Inserting the Main Board into the Chassis*



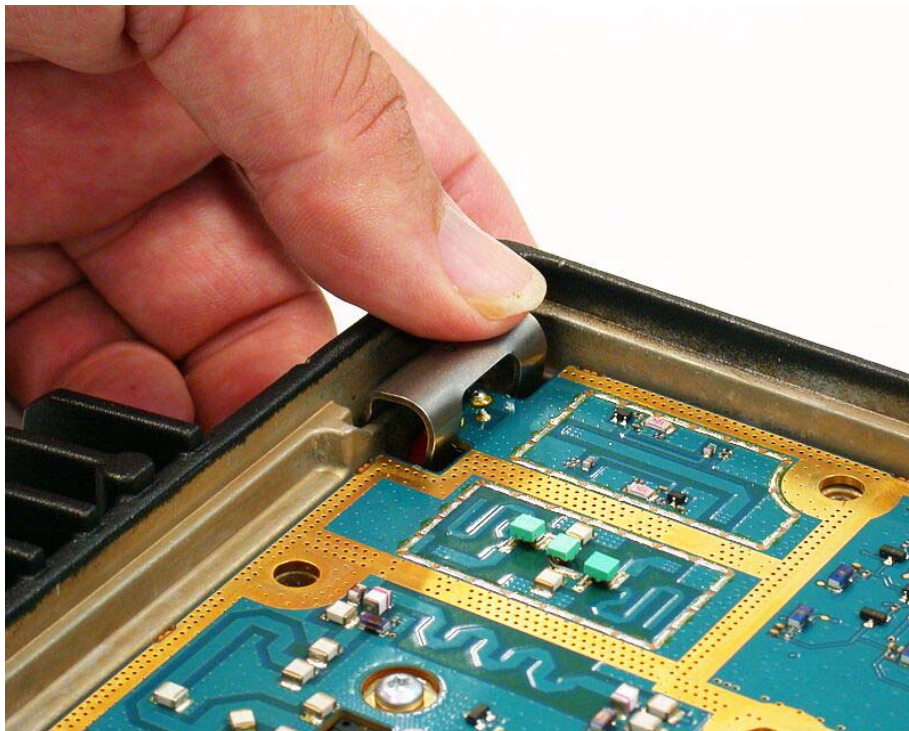
**Caution**

Do not leave the main board in the chassis for extended periods of time without the RF/DC retention clips, or damage to the board connectors may occur.

4. Insert the RF/DC retention clips and fully seat them. The DC clip should be inserted first to properly locate the main board.

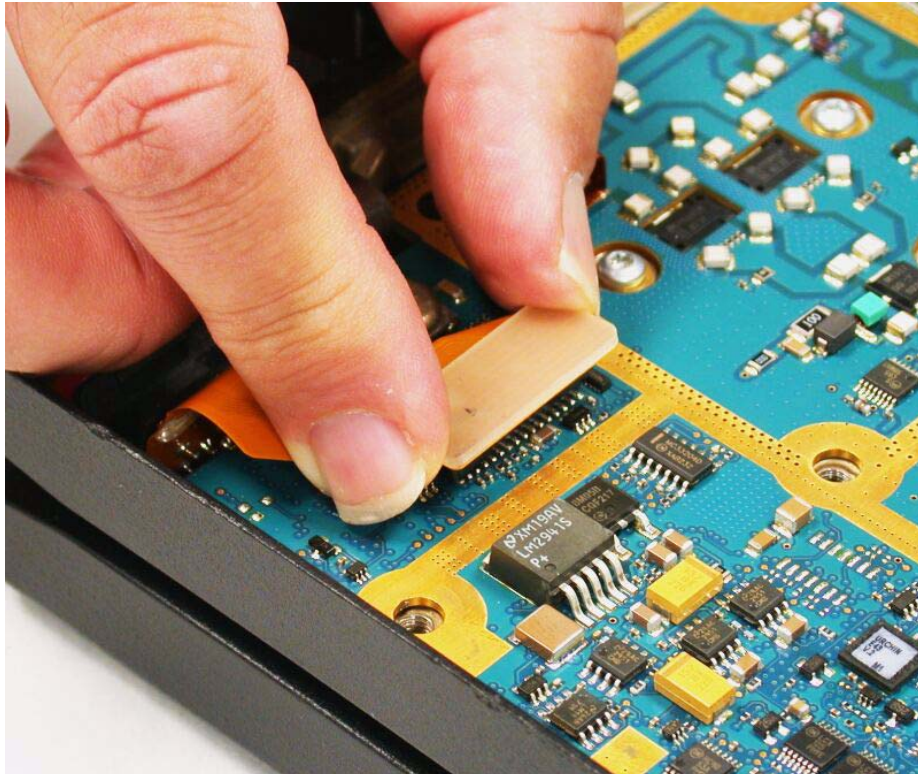


*Figure 8-24. Inserting the RF/DC Retention Clip (DC Side)*



*Figure 8-25. Inserting the RF/DC Retention Clip (RF Side)*

5. Connect the J2 rear accessory connector flex to the PCB.



*Figure 8-26. Connecting the J2 Rear Accessory Connector Flex to the Main Board*

6. Insert and torque the three PA screws to 6-8 in.-lbs. Start all three screws prior to torquing them down.

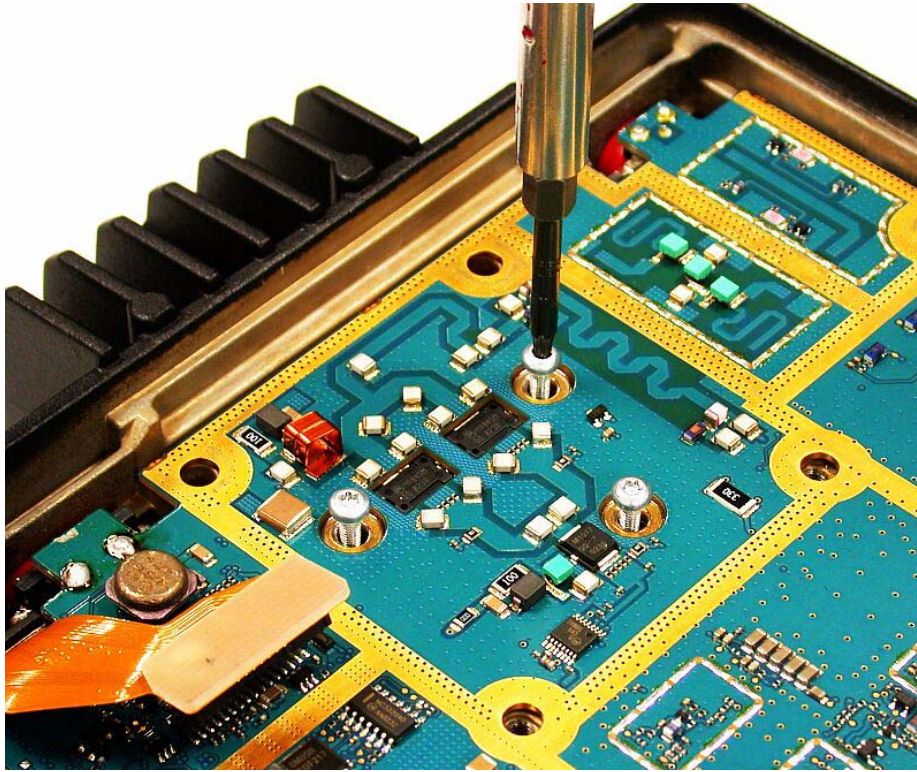


Figure 8-27. Installing the PA Screws

7. Inspect the reverse polarity thermal pad located on the top cover, and then inspect and seat the main seal properly on the cover. Be careful to properly align the tab (see figure below).



Figure 8-28. Inspecting the Thermal Pad and Installing the Cover Main Seal

- Place the cover on the chassis and seat it properly. You can compress the cover and chassis together to squeeze the seal into place and make torquing the screws easier.

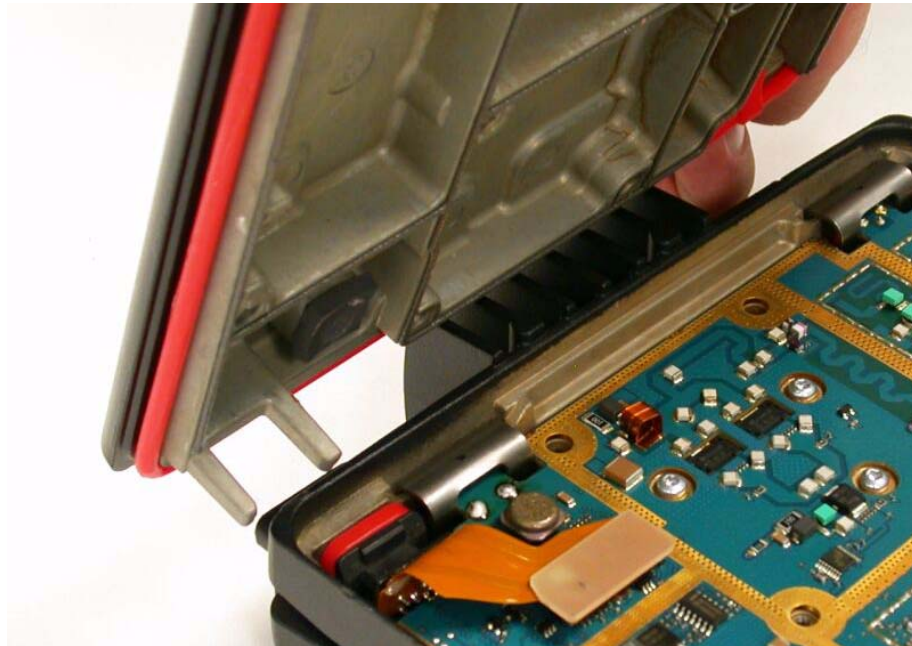


Figure 8-29. Preparing to Place the Top Cover on the Chassis

- Inspect and reassemble the sealing washers to the ten (10) top cover screws, and then torque down screws in the indicated order.

All the screws must be torqued to 24-28 in.-lbs, and you should follow the torque sequence shown in [Figure 8-30](#) at least twice to ensure that each screw is torqued down all the way.

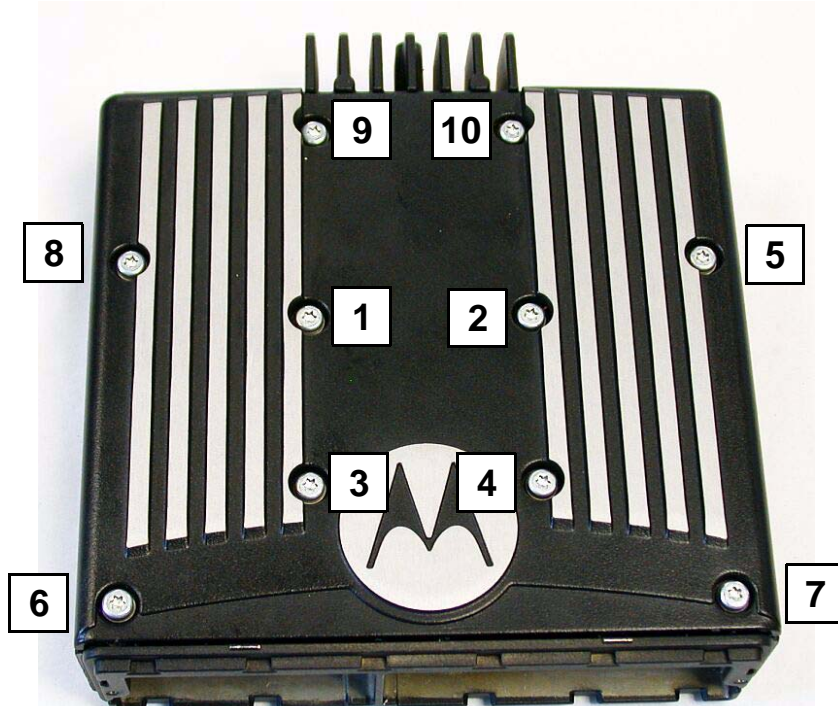


Figure 8-30. Securing the Top Cover to the Chassis

10. For secure option-equipped radios, do the following:
  - a. Inspect the kapton tape on the back of the secure interface board for damage and replace if necessary.
  - b. Ensure the universal encryption module (UCM) is securely plugged into the secure interface board.
  - c. Carefully align the secure interface board in its chassis pocket, and plug it into the main board. Press down along the edges of the board to fully seat it, and then verify that the UCM is still fully plugged in.
  - d. Position the secure shield over the secure interface board, and secure it with the two screws. Torque the screws to 6-8 in.-lbs. using a Torx T10 bit.

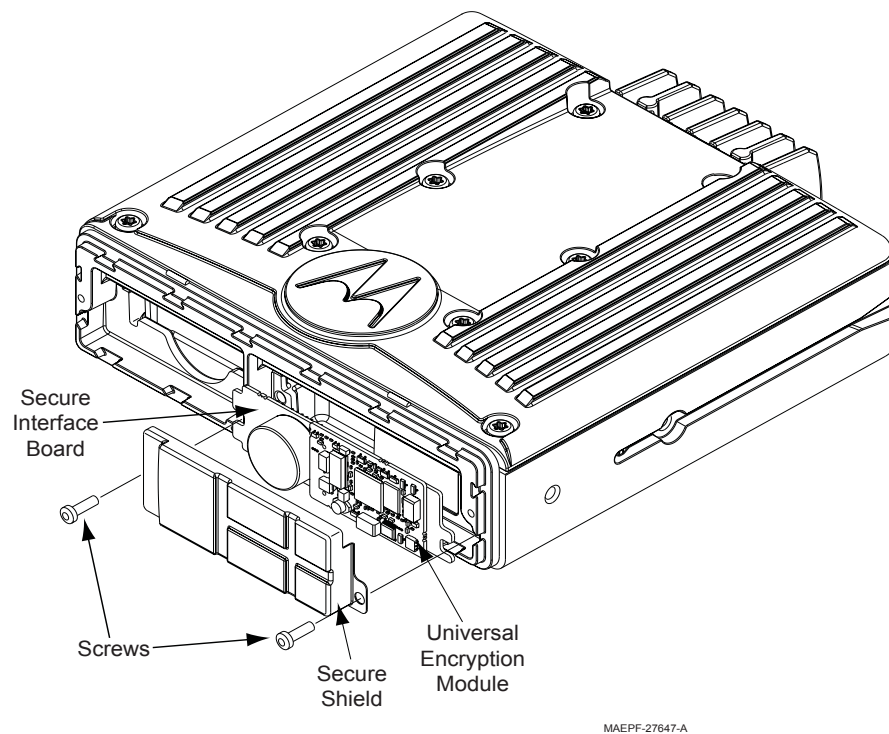


Figure 8-31. Installing the Secure Interface Board

11. Verify that the headbridge seal has no defects; replace the seal if it does.
12. Align the headbridge seal on the transceiver, and insert the seal tabs into their slots along the front edge of the transceiver (Figure 8-32 on page 8-27). Ensure that all the seal tabs are in place.



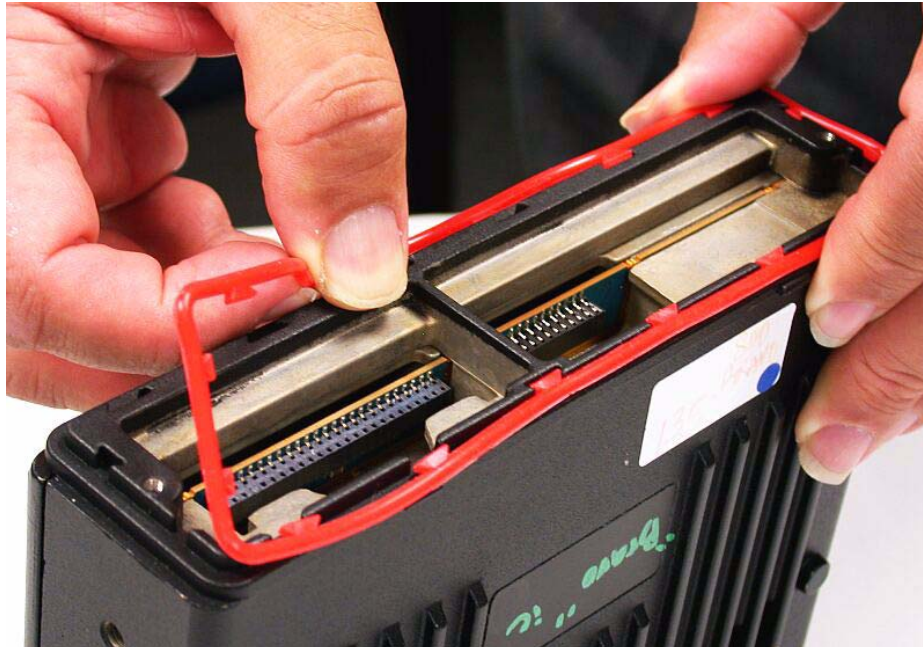


Figure 8-32. Installing the Headbridge Seal

13. Grasp the handle on the transceiver end of the control-head flex (dash or remote), and plug the flex into the 50-pin connector on the side of the main board.

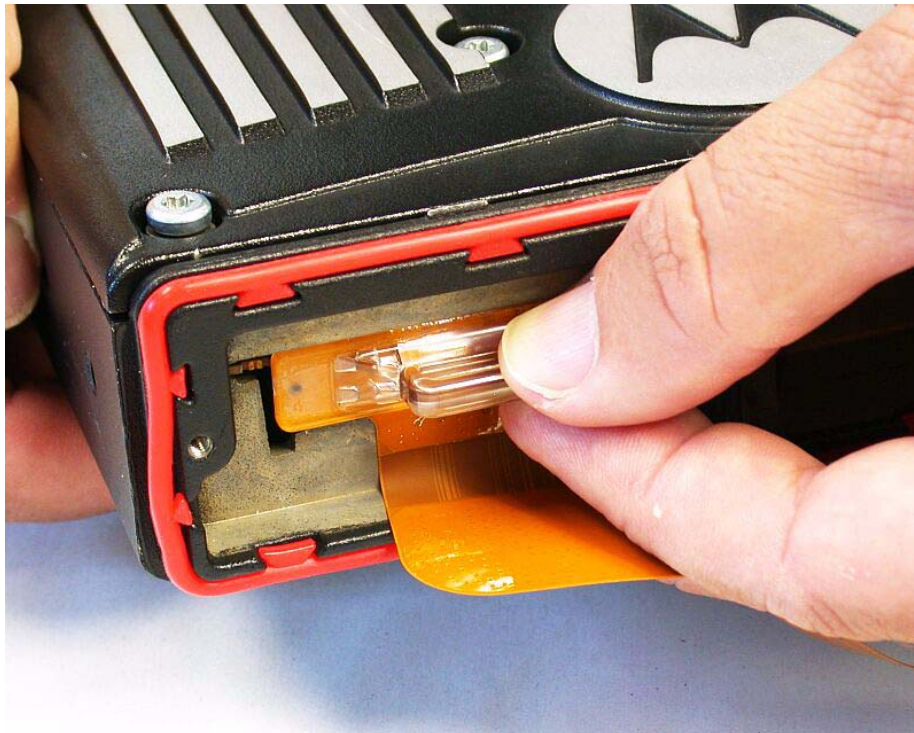


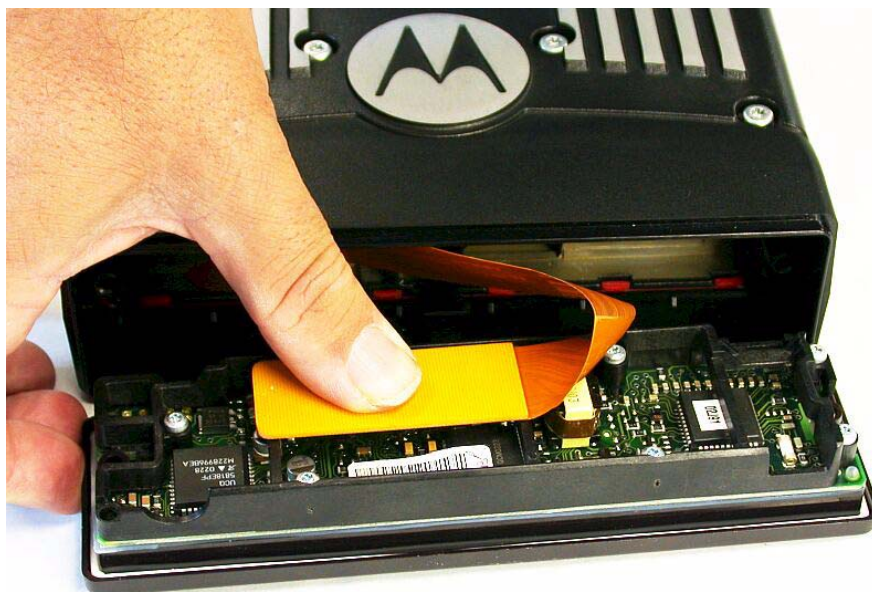
Figure 8-33. Installing the Control-Head Flex in the Transceiver

14. Hold the headbridge with one hand, and squeeze the center of the long span.
15. Align the headbridge with the transceiver, thread the control-head flex through the headbridge, and push the headbridge into place. You might hear a small snap as the alignment tabs engage. If the headbridge does not align properly on the first try, do not try to slide it back and forth on the transceiver. This will cause the seal to roll out of place. Instead, remove the headbridge and try again, taking care to align it properly before fully seating it.



*Figure 8-34. Installing the Headbridge on the Transceiver*

16. Verify that the headbridge seal and all the seal tabs are properly in place.
17. Reinstall the control-head flex onto the control-head connector or remote interface plate.



*Figure 8-35. Installing the Control-Head Flex on the Control Head*

18. Insert the control head to the transceiver.



Figure 8-36. Inserting the Control Head Into the Transceiver

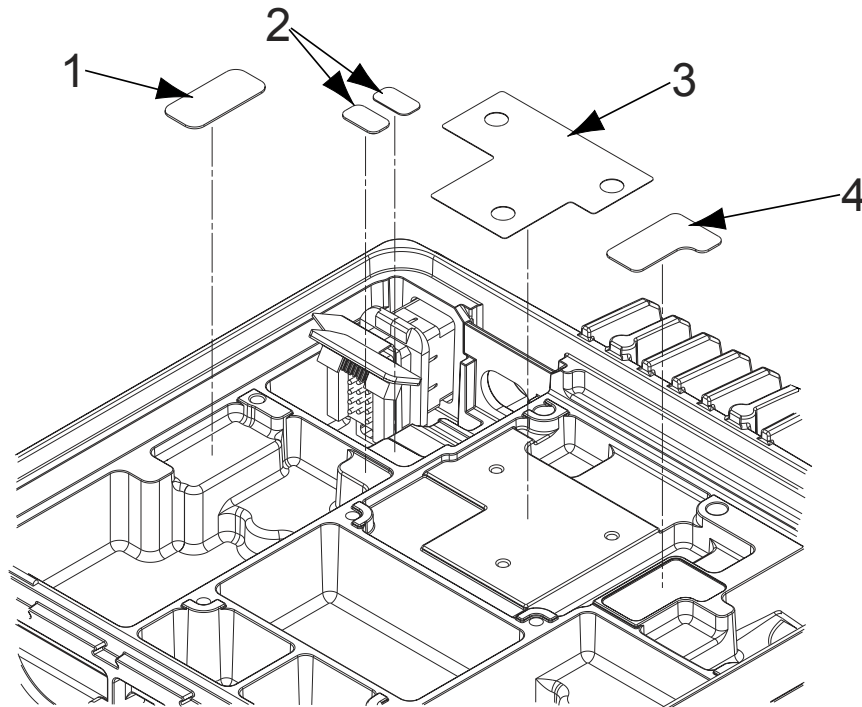
19. Secure the control head to the transceiver with the two screws using the 2.5 mm hex-key bit. Apply 6-8 in.-lbs. of torque for each screw.



Figure 8-37. Installing the Control-Head Screws

### 8.3 Chassis Thermal Pad Replacement Procedure

Use the following procedures for replacing the chassis thermal pads.



MAEPF-27649-O

Figure 8-38. Chassis Thermal Pad Locations

Table 8-2. Chassis Thermal Pad Parts

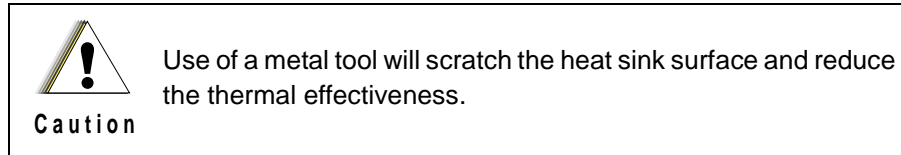
Item No.	Part No.	Description
1	7585366E01	Pad, Thermal, Audio PA
2	7585477E01	Pad, Thermal, Regulator
3	7585365E02	Pad, Thermal, Power Amplifier
4	7585476E01	Pad, Thermal, Harmonic Filter

To replace the pink thermal pads (Items 1, 2, and 4):

1. Use a plastic flat-edge tool (like a black-stick solder aid) to lift the pad from the chassis surface.
2. Discard the old pad. Use a soft cloth to remove any remaining residue. Alcohol can also be used, if necessary. Care should be taken to minimize any cleaning-agent contact with the surrounding shield gasket.
3. Once the surface is clean and dry, use tweezers to remove a new pad from the shipping liner, and place it yellow-side down on the chassis.
4. Apply pressure to the pad to activate the pressure-sensitive adhesive. Remove the blue liner with tweezers.

To repair the black thermal pad (Item 3):

1. Use a plastic flat-edge tool (like a black-stick solder aid) to lift the pad from the chassis surface. The pad is an elastomer-coated sheet of foil. The foil sheet will lift off in pieces. The black elastomer residue will remain on the chassis.
2. Scrape the residue off using a plastic flat-edge tool, such as a dismantling tool (Motorola P/N 6686119B01).



3. After scraping off as much residue as possible, use a soft cloth with alcohol to remove the remaining residue. Care should be taken to minimize any cleaning-agent contact with the surrounding shield gasket.
4. Once the surface is clean and dry, use tweezers to remove a new pad from the shipping liner.
5. Position the pad on the chassis using any two screw holes as a visual cue.
6. Carefully place the pad down to avoid wrinkling the pad or trapping air bubbles under the pad.
7. Apply even pressure to activate the pressure-sensitive adhesive.

To repair the cover pad (7585860F01) shown in the exploded view, [Figure 11.5 “XTL 5000 \(3.5-35 W\) Radio Exploded View” on page 11-6](#):

1. Use a plastic flat-edge tool (like a black-stick solder aid) to lift the pad from the top cover boss.
2. Discard the old pad, and use a soft cloth to remove any remaining residue. Alcohol can also be used, if necessary. Care should be taken to minimize any cleaning-agent contact with the surrounding shield gasket.
3. Once the surface is clean and dry, use tweezers to remove the blue liner from the pad.
4. Place the pad pink-side-down on the cover boss.
5. Use your finger to apply pressure to the pad. The yellow side is visible when the pad is installed correctly.

## 8.4 Fastener Torque Chart

Table 8-3 lists the various fasteners by part number and description, followed by the torque values and the location where used. Torque all fasteners to the recommended value when assembling the radio.

Table 8-3. Fastener Torque Chart

Part Number	Description	Repair Torque (in.-lbs.)	Where Used
0310907A20	Screw, Torx M3x10	6-8	Mainboard (3), Secure Shield (2)
0385870E01	Screw, Torx M4x25	24-28	Top Cover (10)
0380077M07	Screw, Hex M3x35	6-8	Control head (2) and remote interconnect (2) mounting
0310945A11	Screw, Plastite M3x16	6-8	Control Head and remote dash board attachment (varies)
0310945A14	Screw, Plastite M3x8	6-8	Remote control cable cover
0310908A33	Screw, machine	6-8	Back housing W9 control head (3)
0380041S01	Screw, captive	6-8	Control head leaf spring (4)
0380077M04	Screw, hex M3x22	6-8	Remote cable mounting (2)
0384244C06	Wing Screw M5x10	12-16	Radio Mounting (2)

# Chapter 9 Basic Troubleshooting

## 9.1 Introduction

This section of the manual contains troubleshooting charts, error codes, and flexible circuit information. This section can help you isolate a problem to the board level. Board-level troubleshooting does not attempt to isolate problems to the component level. Component-level service information can be found in the *ASTRO XTL 5000 Digital Mobile Radio Detailed Service Manual*. (Refer to the "Related Publications" section of this manual on page xii for the specific manual number.)

**NOTE:** To access the various connector pins, use the housing eliminator/test fixture along with the diagrams found in this section of the manual. (Refer to the section, "Service Aids and Recommended Tools" on page 4-2, for the appropriate Motorola service aids and tools parts numbers.)

### 9.1.1 J2 Accessory Connector

Figure 9-1 illustrates the J2 accessory connector and its associated signals and voltages while Table 9-1 describes the function of each pin.

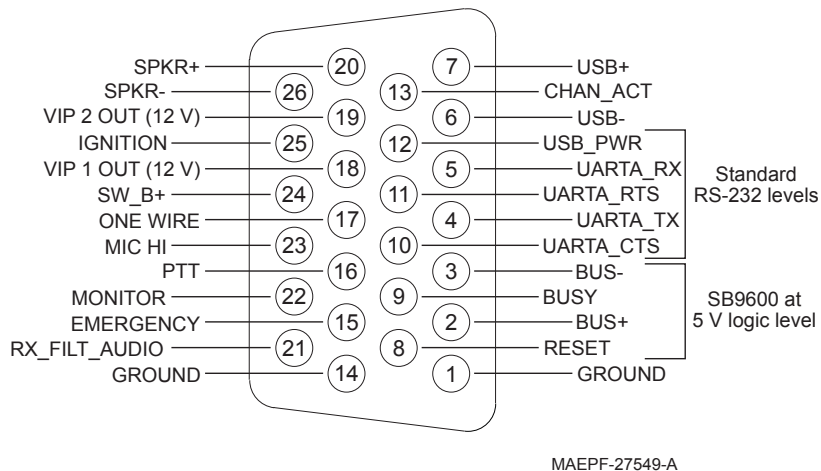


Figure 9-1. J2 Accessory Connector Pin-Out Arrangement

Table 9-1. J2 Accessory Connector Signal and Voltage Descriptions

Pin	Function	Description
1	GROUND	Ground Used as a ground for any reference on rear connector.
2	BUS+	SB9600 BUS+ This is part of the Motorola SB9600 communications bus to connect external devices.
3	BUS-	SB9600 BUS- This is part of the Motorola SB9600 communications bus to connect external devices.

Table 9-1. J2 Accessory Connector Signal and Voltage Descriptions (Continued)

Pin	Function		Description
4	TXD	RS232 Transmit Data	This is part of the 4-wire RS232 interface to external data accessories, programming cables, etc.
5	RXD	RS232 Receive Data	This is part of the 4-wire RS232 interface to external data accessories, programming cables, etc.
6	USB-	USB - Data	This is part of the 2-wire USB differential data bus for future USB accessories.
7	USB+	USB + Data	This is part of the 2-wire USB differential data bus for future USB accessories.
8	RESET	SB9600 RESET	This is part of the Motorola SB9600 communications bus to connect external devices.
9	BUSY	SB9600 BUSY	This is part of the Motorola SB9600 communications bus to connect external devices.
10	CTS	RS232 Clear-To-Send	This is part of the 4-wire RS232 interface to external data accessories, programming cables, etc.
11	RTS	RS232 Request-To-Send	This is part of the 4-wire RS232 interface to external data accessories, programming cables, etc.
12	USB PWR	USB Power	This is the supply (5V) for the USB data bus, supplied by the USB accessory/cable.
13	CHAN ACT	Channel Activity	This is an output used for indicating detection/unsquelching of a qualified received signal.
14	GROUND	Ground	Used as a ground for any reference on rear connector.
15	EMERGENCY	Emergency	This pin must be connected to ground by jumper on accessory cable if emergency is disabled, even if disabled by CPS. If enabled, this line must be grounded via a switch, which is normally closed. The emergency debounce time is programmable via CPS.
16	PTT*	Push To Talk	Pulling this line to ground will activate PTT function, activating the AUX_MIC input.
17	ONE WIRE	One-Wire data	To be used for identification of future smart accessories/cables.
18	VIP OUT 1	Vehicular Interface Output	High voltage output used for enabling relays used for accessories such as horn/lights.
19	VIP OUT 2	Vehicular Interface Output	High voltage output used for enabling relays used for accessories such as horn/lights.
20	SPKR+	Speaker +	Used along with SPKR- to connect an external speaker. The audio PA is a bridge amplifier with a 3.2-ohm minimum impedance.



Table 9-1. J2 Accessory Connector Signal and Voltage Descriptions (Continued)

Pin	Function		Description
21	RX FILT AUDIO	Receive Filtered Audio Out	This is a fixed level (independent of volume level) received audio signal, including alert tones. Flat or de-emphasis are programmed by CPS. Output voltage is approximately 100 mVrms per 1kHz of deviation. The DC offset is 1.4V.
22	MONITOR	Monitor overrides PL	This output is used to detect when a rear microphone accessory is taken 'off-hook', to over-ride PL to alert the user to busy traffic prior to transmitting.
23	AUX MIC	Rear microphone input	This microphone signal is independent of the microphone signal on the front microphone connector. The nominal input level is 80mVrms for 60% deviation when used for motorcycle, but can also support 300 mVrms for future APCO accessories. The DC impedance is 660 ohms and the AC impedance is 560 ohms.
24	SW B+	Switched Battery Voltage	This voltage is available when the radio is switched on, at A+ levels.
25	Ignition	Ignition Sense	Connecting this line to the ignition line of the vehicle will allow radio turn-on via the on/off button when the vehicle ignition is on. Connecting this line to the car battery will allow radio turn-on via the on/off button, regardless of the vehicle ignition status.
26	SPKR-	Speaker -	Used along with SPKR+ to connect an external speaker. The audio PA is a bridge amplifier with a 3.2-ohm minimum impedance.

### 9.1.2 I/O Disclaimer

Some of the signal lines on the J2 accessory connector (Figure 9-1, on page 9-1) are limited to between 0- and 5-volt operation. It is obvious that improper connections to any electronic device might result in damage. Some of the logic lines are limited to between 0 and 5 volts and other inputs between 0 and 20 volts. The exception is the UARTA, which can tolerate up to  $\pm 15$  V maximum. At no time should any two (or more) outputs be connected together. Exceeding these input voltages or output loads could result in electronic component failure. In most cases Zener diodes have been added to protect against ESD.

Table 9-2 provides the normal operation range and ESD clamping voltages at accessory connector J2. If a radio is suspected of failure due to improper connections, the table can be useful in diode-continuity testing the accessory pins on the radio as a closed unit.

Table 9-2. Normal Operation Range and ESD Clamping Voltages

DB26 (Pins)	Female	Reverse Bias Voltage at Port J2*	Voltage at Port J2**
1	Ground	0	0.00
2	Bus +	0.7	4.30
3	Bus -	0.7	0.45
4	UARTA_TxD	High Z	-9.20

Table 9-2. Normal Operation Range and ESD Clamping Voltages (Continued)

DB26 (Pins)	Female	Reverse Bias Voltage at Port J2*	Voltage at Port J2**
5	UARTA_RxD	5.5 K	0.00
6	USB -	0.50	0.09
7	USB +	0.51	0.07
8	RESET	0.51	0.00
9	BUSY	0.50	0.00
10	UARTA_CTS	High Z	9.20
11	UARTA_RTS	5.5 K	0.00
12	USB_PWR	0.7	0.00
13	CHAN_ACT	1	0.03
14	Ground	0	0.00
15	Emergency	59 K	1.90
16	PTT	0.8	2.80
17	One wire	0.7	2.80
18	VIP OUT 1 (12V)	1	0.08
19	VIP OUT 2 (12V)	1	0.07
20	Spkr +	0.8	6.60
21	RX_FILT_audio	1	1.30
22	Monitor	0.8	2.80
23	AUX_MIC	1	9.13
24	SW_B+	0.7	13.7
25	Ignition	0.8	13.8
26	Spkr -	0.8	6.70
* Measured without power applied to the radio, the DMM on the diode-test scale, and the lead connected to chassis ground. 0.7 V, 0.8 V, and 1 V measurement represent diode junctions that will vary depending on the bias current of the ohmmeter.			
** Measured with a voltmeter and the radio powered on using a 13.8-volt power supply.			

### 9.1.3 Microphone Bias

Most microphones are powered by a phantom power supply. This means that the bias to the electronics within the microphone is supplied as DC (direct-coupled) down the MIC\_IN line. During PTT (push-to-talk or transmit), the microphone electronics are connected to this line and loads it down from 9 V to a bias voltage between about 3 to 6 volts. The AC load (or load line) is less than 560 ohms at the radio due to AC decoupling on both sides of this resistor. Audio (which is AC) from the microphone passes up the same MIC\_IN line and AC coupled eventually to a high impedance amplifier circuit. It is imperative that this input has a bias voltage between 1.5 and 9.5 volts. Connecting to anything other than a microphone could short out or clamp the input signal resulting in distortion. The output of other types of electronics is typically referenced to zero volts DC and would require a 10  $\mu$ F capacitor to be placed in series with MIC\_IN. If the capacitor is polarized, the plus lead goes to the radio MIC\_IN. Some audio generators have the option of applying the 1.5 Vdc offset, which may be used in place of a capacitor.

### 9.1.4 Audio PA Out Bias

The audio PA is a BTL (bridge-to-load) amplifier. When the radio is in receiver mode, the output of both speaker leads bias up to half of the supply voltage. Considering that both leads are at the same potential, the average DC voltage across the load is zero. At maximum volume the signal voltage to the load is double that of one amplifier peak-to-peak because the amplifiers work together 180 degrees out of phase. Caution must be taken not to short either lead to ground, which might cause component damage. Even though audio may still be heard from the speaker, the shorted side will go into current limiting and eventually into thermal shutdown, shutting off the amplifier. These protection devices are not intended to be tested.

### 9.1.5 High Power RF Precaution



#### Caution

When performing *both* transmit and, especially, receive tests, it is still possible that equipment might be damaged by the radio transmitter. Besides a possible radio failure, the radio might also transmit while in receive under the following conditions: trunking-mode affiliation, missing emergency jumper, a defective PTT button, or other unintentional PTT activations.

With the exception of some inputs on service monitors, a suitable attenuator rated at 100 W or more should always be used with all test equipment connected to the RF connector.

## 9.2 Replacement Board Procedures

Once a problem has been isolated to a specific board, use one of the following recommended repair procedures:

- Install a good board from your inventory into the radio.
- Order a replacement board from Radio Products Services Division at 1-800-422-4210. Refer to ["Appendix A Replacement Parts Ordering"](#) on page A-1 for further information.
- Troubleshoot the defective board using the *ASTRO XTL 5000 Digital Mobile Radios Detailed Service Manual*. (Refer to the ["Related Publications"](#) section of this manual on page xii for the specific manual number.)

## 9.3 Power-Up Error Codes

When the radio is turned on (power-up), the radio performs cursory tests to determine if its basic electronics and software are in working order. Problems detected during these tests are presented as error codes on the radio's display. The presence of an error should prompt the user that a problem exists and that a service technician should be contacted.

Self-test errors are classified as either fatal or non-fatal. Fatal errors inhibit user operation; non-fatal errors do not. Use the following tables to aid in understanding particular power-up error code displays.

Table 9-3. Power-Up Error Codes

Error Code	Description	Error Type	Corrective Action
ERROR 01/02	FLASH ROM Codeplug Checksum	NON-FATAL	Reprogram the codeplug.
ERROR 01/12	Security Partition Checksum	NON-FATAL	Reprogram the security partition.

Table 9-3. Power-Up Error Codes (Continued)

Error Code	Description	Error Type	Corrective Action
ERROR 01/22	Tuning Codeplug Checksum	NON-FATAL	Reprogram the tuning partition.
FAIL 01/81	FLASH ROM Checksum	FATAL	Reprogram the radio firmware.
FAIL 01/82	FLASH ROM Codeplug Checksum	FATAL	Reprogram the codeplug.
FAIL 01/88	External SRAM Failure	FATAL	Turn the radio off, then on.
FAIL 01/90	General Hardware	FATAL	Turn the radio off, then on.
FAIL 01/92	Security Partition Checksum	FATAL	Reprogram the security partition.
FAIL 01/93	FlashPORT AUTHENT CODE Failure	FATAL	Contact the depot.
FAIL 01/98	Internal RAM Failure	FATAL	Turn the radio off, then on.
FAIL 01/A2	Tuning Codeplug Checksum	FATAL	Reprogram the tuning partition.
FAIL 02/81	DSP ROM Checksum	FATAL	Reprogram the DSP firmware.
FAIL 02/88	DSP RAM Fatal Error	FATAL	Turn the radio off, then on.
FAIL 02/90	General DSP Hardware Failure	FATAL	Turn the radio off, then on.
ERROR 05/10	Control Head Hardware Error	NON-FATAL	Turn the radio off, then on.
FAIL 05/81	Control Head ROM Checksum Error	FATAL	Replace the control head.
ERROR 06/10	Aux Control Head Hardware Error	NON-FATAL	Turn the radio off, then on.
FAIL 06/81	Aux Control Head ROM Checksum Error	FATAL	Replace the aux. control head.
ERROR 08/10	Siren Hardware Error	NON-FATAL	Turn the radio off, then on.
FAIL 08/81	Siren ROM Checksum Error	FATAL	Replace the siren.
ERROR 09/10	Secure Hardware Error	NON-FATAL	Replace the secure module.
FAIL 09/90	Secure Hardware Fatal Error	FATAL	Replace the secure module.
ERROR 12/10	VRS Hardware Error	NON-FATAL	Turn the radio off, then on.
FAIL 12/81	VRS ROM Checksum Error	FATAL	Replace the VRS.
ERROR 1C/10	TRC Hardware Error	NON-FATAL	Turn the radio off, then on.
FAIL 1C/81	TRC ROM Checksum Error	FATAL	Replace the TRC.
FL 01/AO	Abacus IC Failure	FATAL	Turn the radio off, then on.
FL 02/CO	Wrong microprocessor	FATAL	Send the radio to the depot; replace the daughter card.

## 9.4 Operational Error Codes

During radio operation, the radio performs dynamic tests to determine if the radio is working properly. Problems detected during these tests are presented as error codes on the radio's display. The presence of an error code should prompt a user that a problem exists and that a service technician should be contacted. Use [Table 9-4](#) to aid in understanding particular operational error codes.

Table 9-4. Operational Error Codes

Error Code	Description	Error Type	Corrective Action
FAIL 001	Synthesizer Out-of-Lock	NON-FATAL	1. Reprogram the codeplug. 2. Refer to Detailed Service Manual.
FAIL 002	Personality checksum or system block error	NON-FATAL	Reprogram the codeplug.

## 9.5 Transmitter Troubleshooting

[Table 9-4](#) can help you troubleshoot problems that might occur in the transmitter section of your radio.

Table 9-5. Transmitter Troubleshooting Chart

Symptom	Possible Cause	Correction or Test (Measurements Taken at Room Temperature)
No RF Power Output	TX Power Level Programming	Check TX power level programming (from the appropriate radio-programming software).
	Main Board	Refer to the Detailed Service Manual.
Distorted Modulation	Bandwidth	Is the correct bandwidth selected (use the appropriate radio-programming software)? Is radio properly tuned? (See <a href="#">Chapter 6: Radio Alignment Procedures</a> .)
	Compensation Not Set/ Working (DPL Distorted)	Check the compensation setting. If compensation won't adjust, go to "Can't Set Compensation" below.
	Main Board	Refer to the Detailed Service Manual.
No Modulation, Bad Microphone Sensitivity	Check Deviation and Compensation	Retune, if necessary. (See <a href="#">Chapter 6: Radio Alignment Procedures</a> .)
	Microphone	Speak loudly into the microphone while monitoring the microphone line (pin 4 of J0401). If it is not >80 mVrms, then check the microphone, flex, control head, and remote cable if applicable.
	Main Board	If >80 mVrms, refer to the Detailed Service Manual.
No/Low Signaling (PL, DPL, Trunking, MDC)	Check Programming	Reprogram the codeplug.
Can't Set Compensation	Deviation and Compensation	Vary deviation and compensation controls from maximum to minimum using softpots in the TX Deviation Balance screen and TX Deviation Limit screen (using the appropriate radio-programming software—see <a href="#">Chapter 6: Radio Alignment Procedures</a> ).
	Main Board	Refer to the Detailed Service Manual.

Table 9-5. Transmitter Troubleshooting Chart (Continued)

Symptom	Possible Cause	Correction or Test (Measurements Taken at Room Temperature)
Radio transmits when programming cable is inserted into control head	Damaged Flex	Replace flex to control head.

**NOTE:** "AC-coupled" is adding a 10  $\mu$ f capacitor externally to prevent biasing on the MIC-HI line from being grounded.

## 9.6 Receiver Troubleshooting

Table 9-6 can help you troubleshoot problems that might occur in the receiver section of your radio.

Table 9-6. Receiver Troubleshooting Chart

Symptom	Possible Cause	Correction or Test (Measurements Taken at Room Temperature)
Radio Dead, Display Does Not Light Up	Blown Fuse	Check the current if drain is >800 ma or if the current is <400 ma, refer to the Detailed Service Manual for mainboard repair. Check the fuse in the red lead of power cable (or green lead if used.)
	Main Board	Check for ignition at J0401-20 and at J0401-19 and 21 (both >10 Vdc). If not present, refer to the Detailed Service Manual.
	On/Off Switch (Control Head)	Check for SW_B+ at pin 17 of J0401 on the main board. If present, replace flex or remote cable and board. If absent, replace control head.
Radio Dead, Display Lights Up	Flex Circuit	Check for SW_B+ at pin 17 of J0401. If absent, replace the flex or remote cable/board.
	Main Board	Refer to the Detailed Service Manual.
No Receiver Audio or Receive Does Not Unsquench	Code Plug	Check the codeplug to ensure correct frequency and signaling (PL, DPL) is enabled (use the appropriate radio-programming software).
	Speaker	Check for speaker leads shorted to ground or open speaker wires. Replace, if necessary.
	Main Board	Refer to the Detailed Service Manual.
Audio Distorted or Not Loud Enough	Codeplug	Ensure the codeplug is properly configured, including bandwidth and signaling.
	Synthesizer Not On Frequency/Working	See "Reference Oscillator Alignment" on page 6-6.
	Main Board	Refer to the Detailed Service Manual.
RF Sensitivity Poor	Synthesizer Not On Frequency/Working	Check the local oscillator frequency. See "Reference Oscillator Alignment" on page 6-6.
	Main Board	Refer to the Detailed Service Manual.

Table 9-6. Receiver Troubleshooting Chart (Continued)

Symptom	Possible Cause	Correction or Test (Measurements Taken at Room Temperature)
Radio Will Not Squelch	Codeplug	Check the offending channel for spurious activity by monitoring with a known-good radio or service monitor. If possible, remove the offending source (computer, etc.). If not, increase the squelch level using the appropriate radio-programming software.
Radio Will Not Turn Off	On/Off Switch (Control Head)	Check for SW_B+ at 0 Vdc on pin 17 J0401 on the main board. If SW_B+ is >1 Vdc, replace the control head.
	Emergency Switch	Check the emergency signal at J0401-18. A high voltage may indicate that the emergency switch line is not grounded by the rear accessory cable.
	Main Board	Refer to the Detailed Service Manual.
Excessive Noise in Fading Conditions	Check Programming for Correct Bandwidth	Reprogram the codeplug with the correct bandwidth.
Radio transmits when programming cable is inserted into control head	Damaged Flex	Replace flex to control head.

## Notes



---

## Chapter 10 Functional Block Diagrams and Connectors

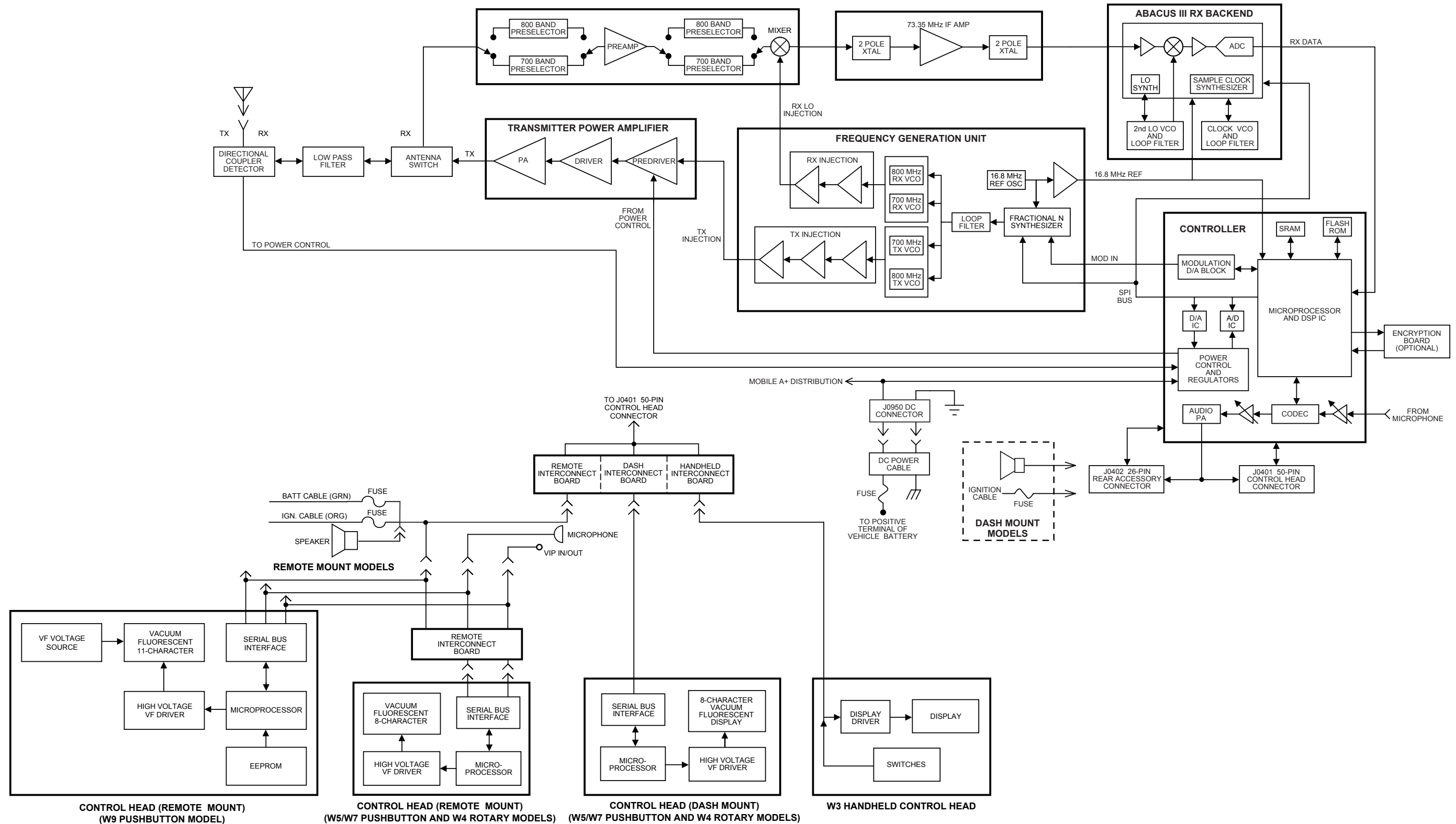
This chapter contains the ASTRO XTL 5000 digital mobile radio functional block diagrams and connector locations.

*Table 10-1. Table of Functional Block Diagrams and Connectors*

Page	Figure Name
10-2	Figure 10-1. ASTRO XTL 5000 Functional Block Diagram
10-3	Figure 10-2. J0103 Remote-Mount Control Head Connector
10-3	Figure 10-3. J5 Control Cable for Remote-Mount Control Head
10-3	Figure 10-4. J6 Radio Operations Connector
10-3	Figure 10-5. J3 Remote-Control Cable Accessory Connector
10-3	Figure 10-6. J2 Rear Accessory Connector
10-3	Figure 10-7. P104 Microphone Jack
10-4	Figure 10-8. Dash-Mount Radio Connector Locations
10-4	Figure 10-9. Remote-Mount Radio Connector Locations
10-4	Figure 10-10. Main Board Connector Locations - Side 1
10-4	Figure 10-11. Main Board Connector Locations - Side 2
10-5	Figure 10-12. Control Head Cabling Diagram
10-6	Figure 10-13. Control Head 50-pin Connector
10-7	Figure 10-14. XTL 5000 Radio Connector Naming Scheme

---

### 10.1 XTL 5000 Functional Block Diagram



MAEPF-27633-O

Figure 10-1. ASTRO XTL 5000 Functional Block Diagram

## 10.2 Radio Connectors

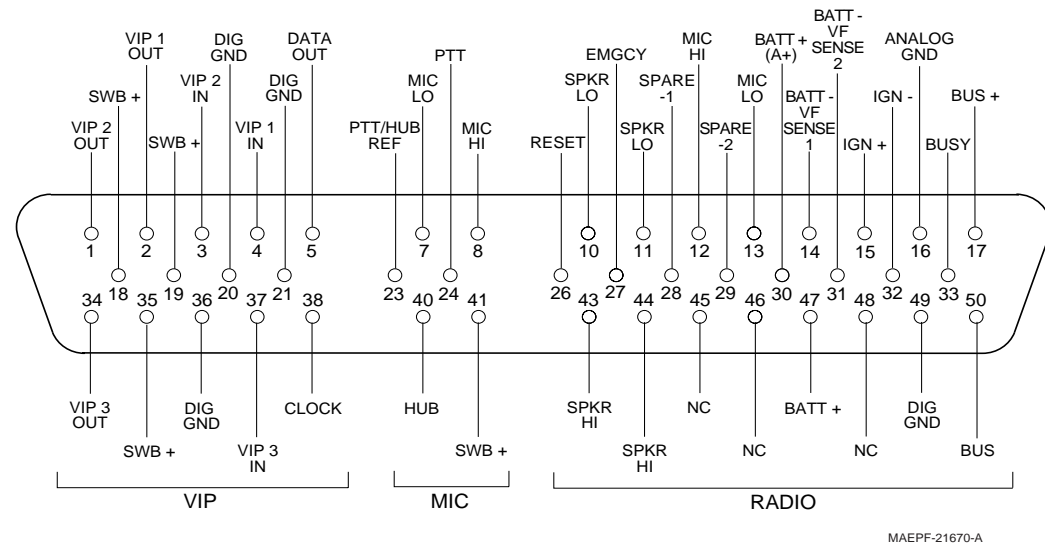


Figure 10-2. J0103 Remote-Mount Control Head Connector

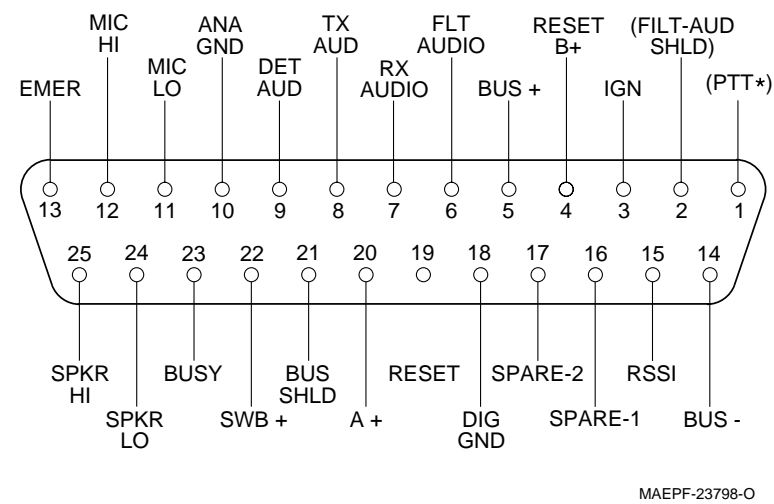


Figure 10-3. J5 Control Cable for Remote-Mount Control Head

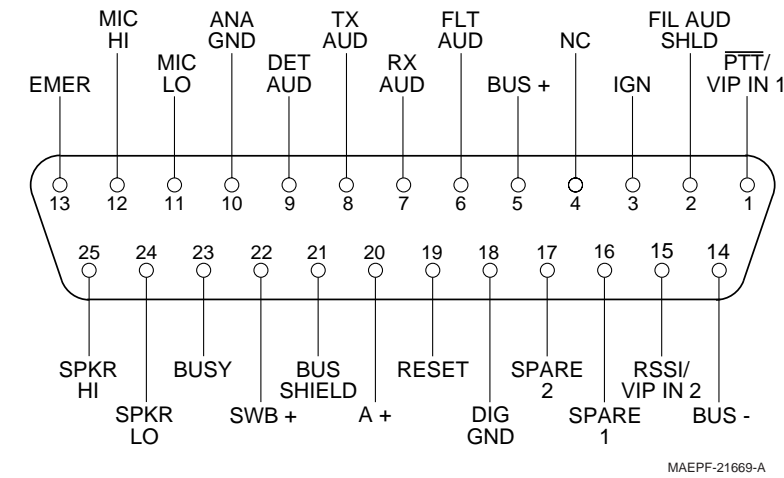


Figure 10-4. J6 Radio Operations Connector

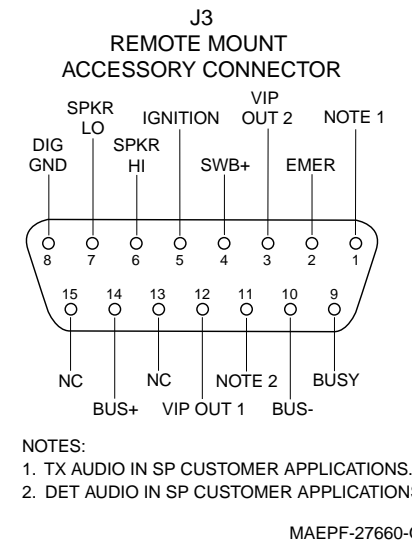


Figure 10-5. J3 Remote-Control Cable Accessory Connector

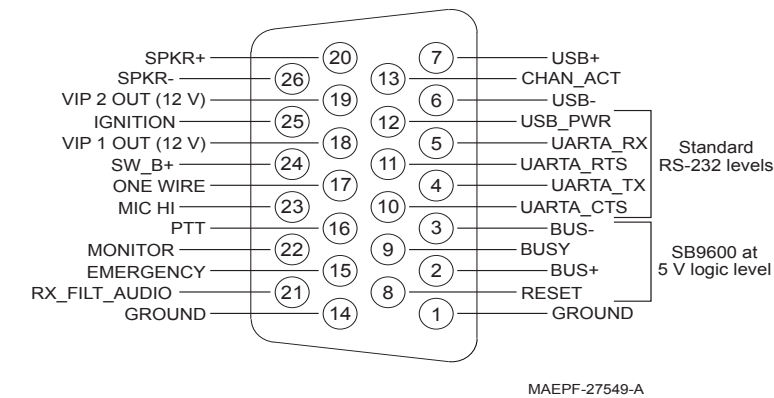


Figure 10-6. J2 Rear Accessory Connector

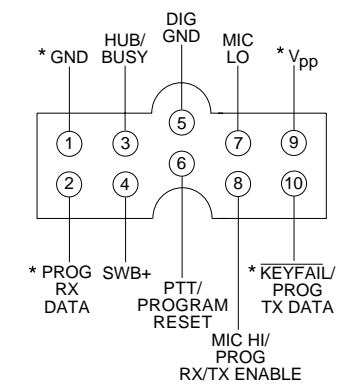
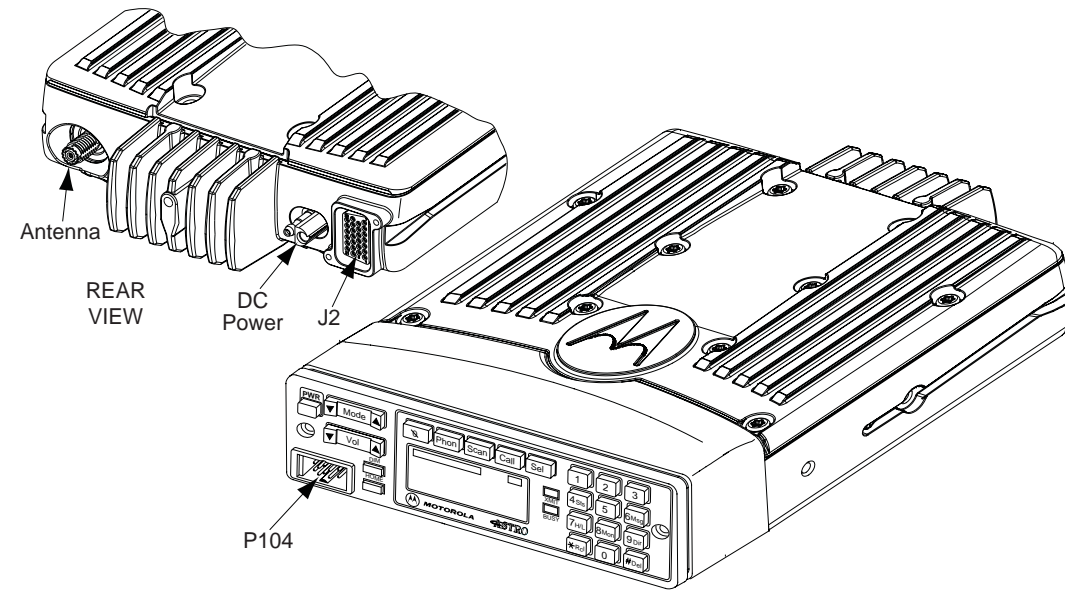


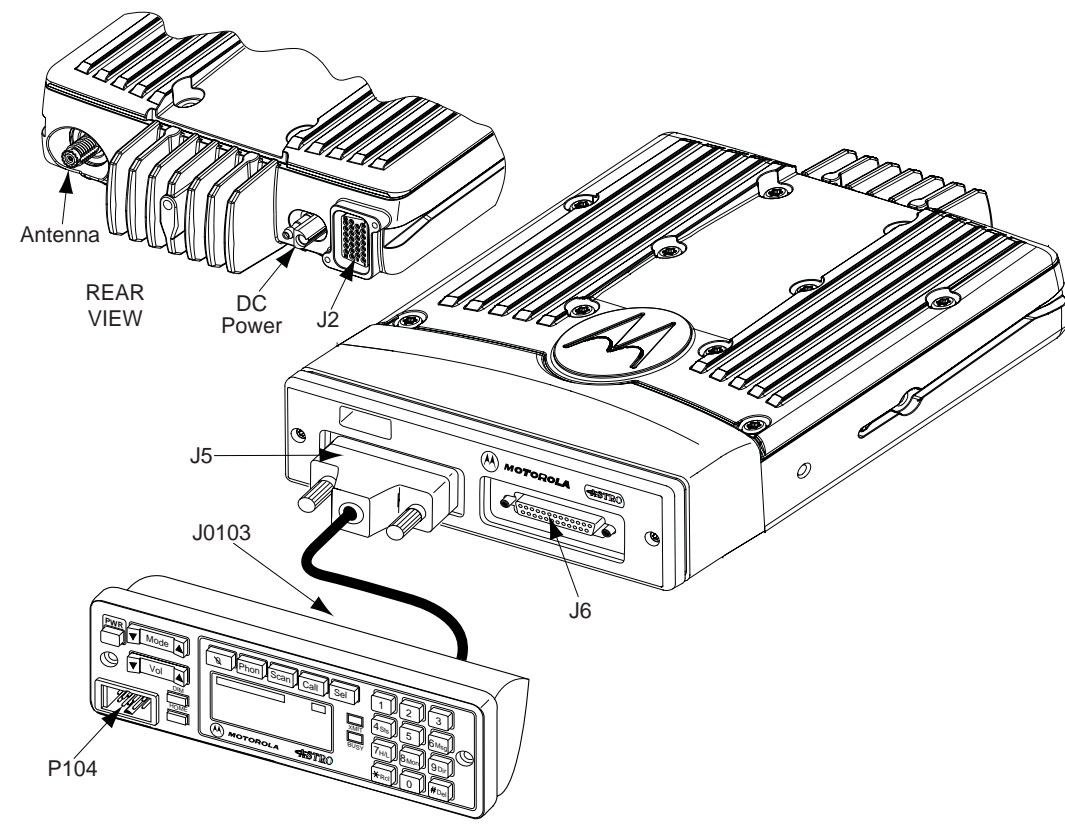
Figure 10-7. P104 Microphone Jack

### 10.3 Radio Connector Locations



MAEPF-27645-A

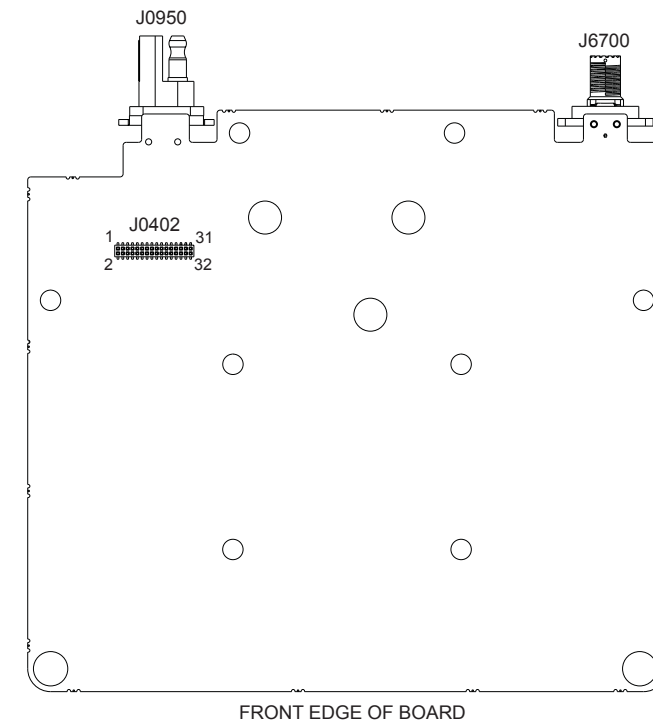
Figure 10-8. Dash-Mount Radio Connector Locations



MAEPF-27644-A

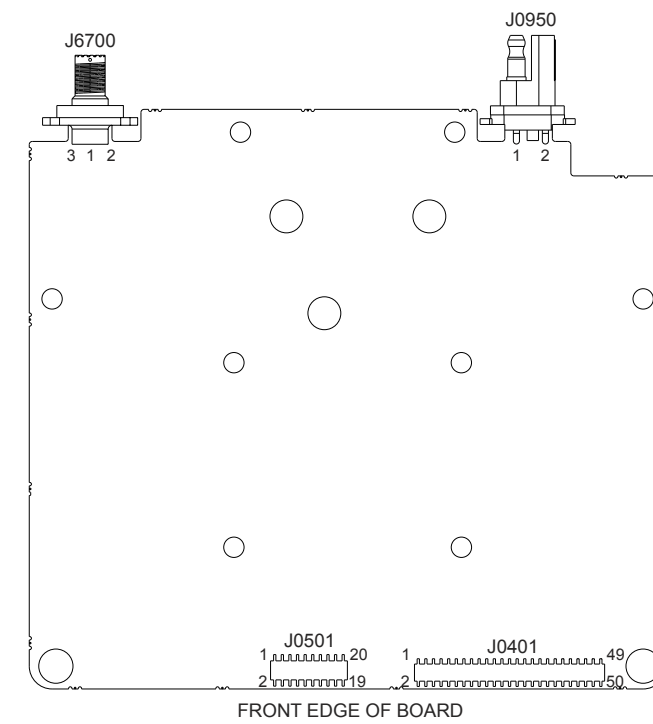
Figure 10-9. Remote-Mount Radio Connector Locations

### 10.4 Radio Connector Locations (cont.)



MAEPF-27663-O

Figure 10-10. Main Board Connector Locations - Side 1



MAEPF-27664-O

Figure 10-11. Main Board Connector Locations - Side 2

### 10.5 Control Head Cabling Diagram

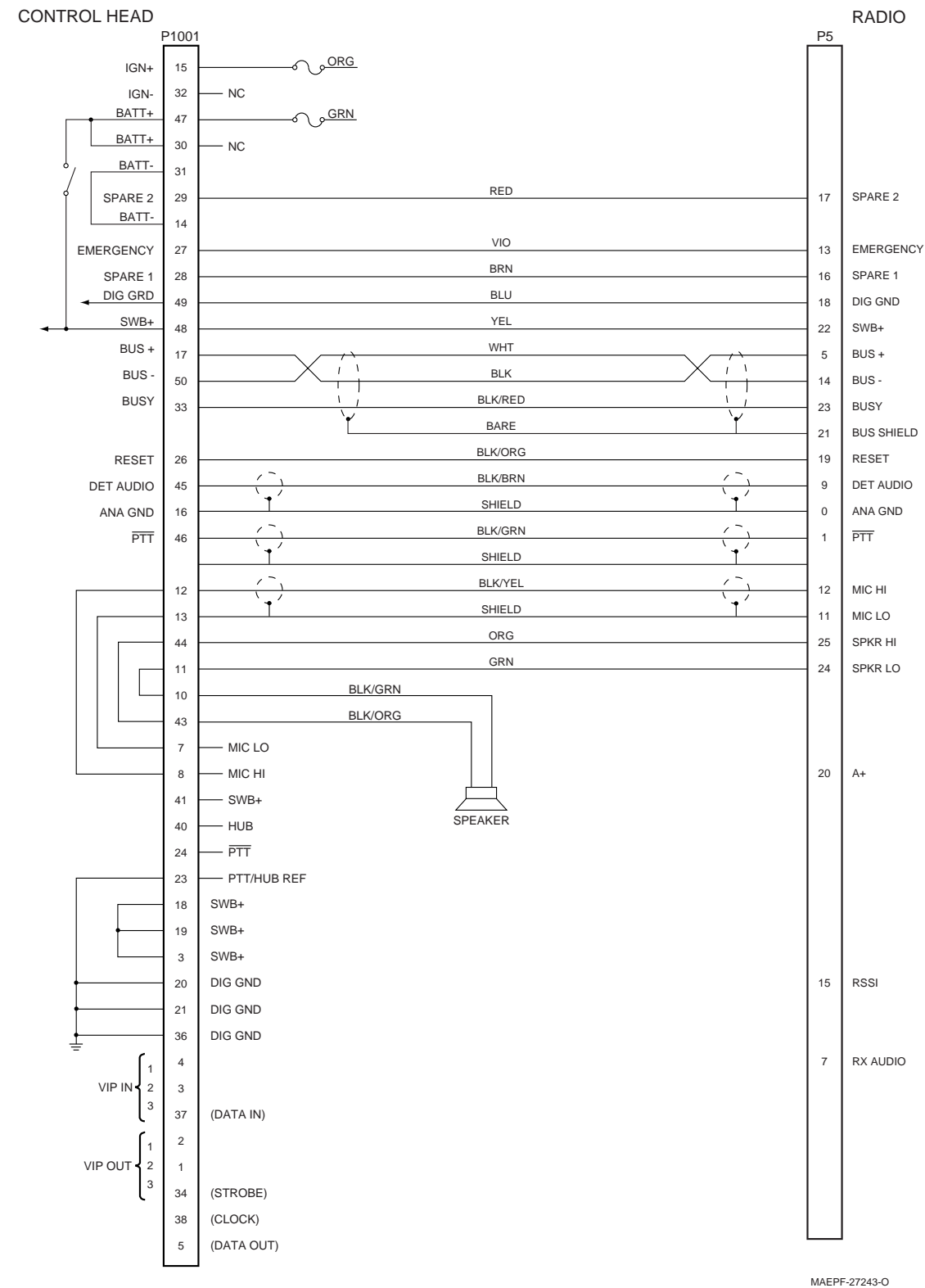


Figure 10-12. Control Head Cabling Diagram

### 10.6 Control Head Connector

Figure 10-13 illustrates the pin arrangement and associated signals and voltages for the 50-pin control-head connector.

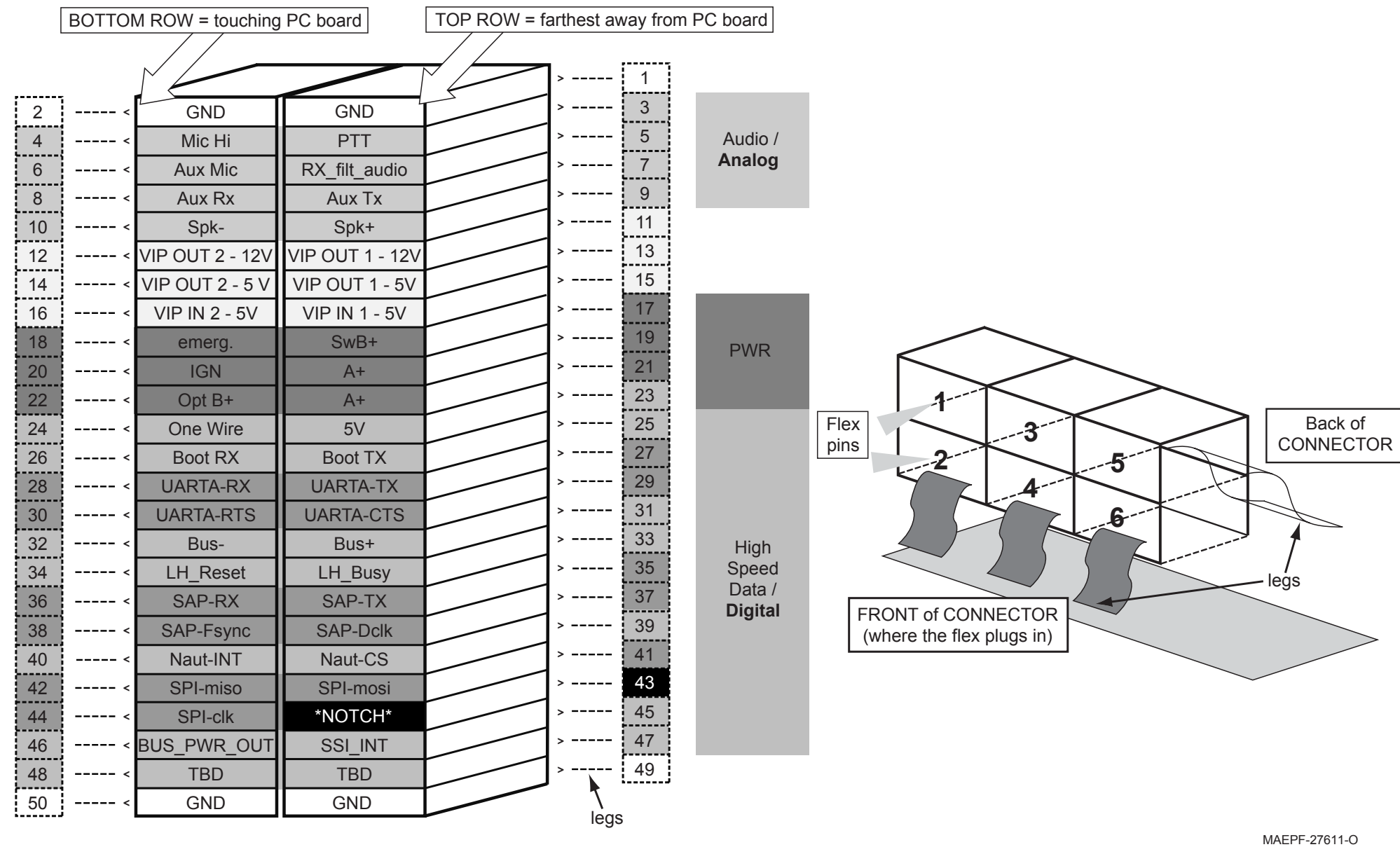
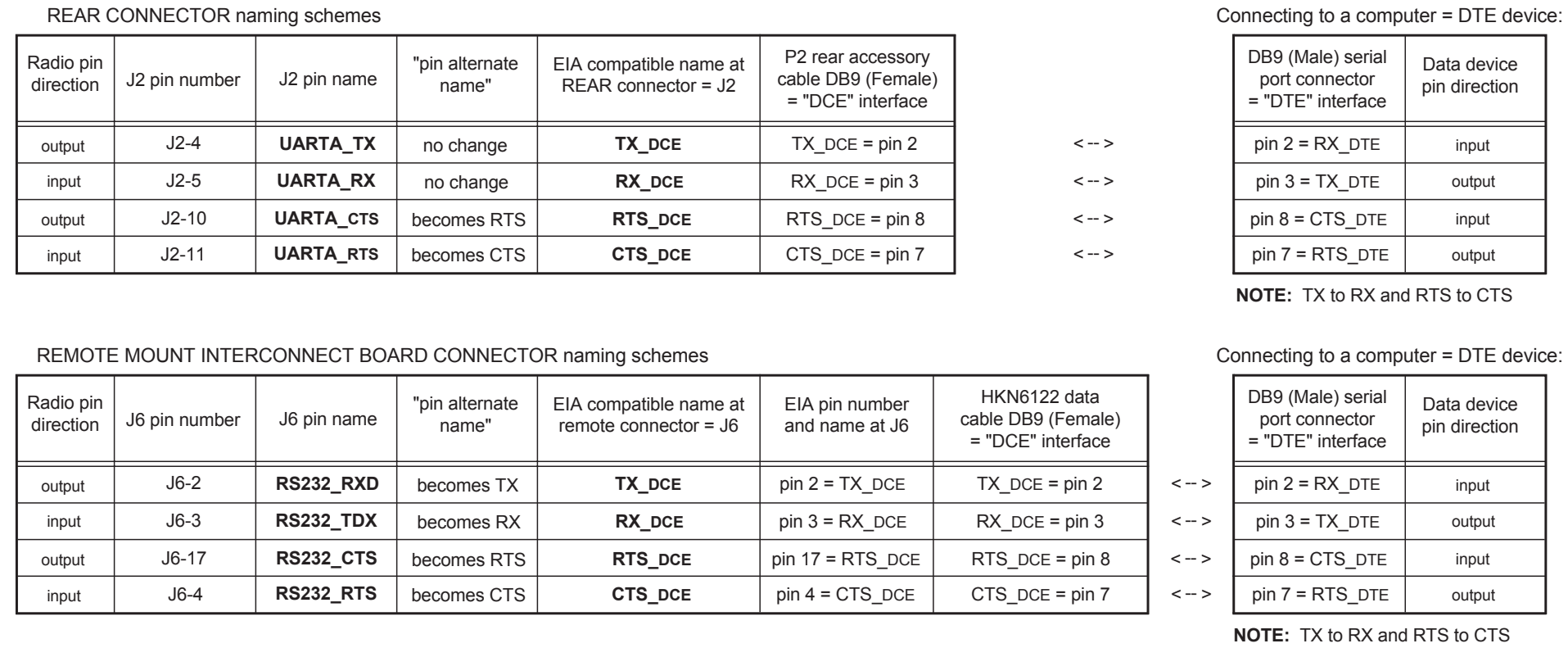


Figure 10-13. Control Head 50-pin Connector

MAEPF-27611-O

## 10.7 Connector Naming Schemes

Figure 10-14 illustrates the differences between the XTL 5000 radio connector computer data and control signal names as these signals pass from one connector to another.



MAEPF-27610-A

Figure 10-14. XTL 5000 Radio Connector Naming Scheme

## Notes



---

## Chapter 11 Exploded Views and Parts Lists

This chapter contains the exploded views and associated parts lists for the ASTRO XTL 5000 digital mobile radio and accessories. Tables containing pushbutton parts lists are also included at the end of this chapter.

Table 11-1. Table of Exploded Views

Page	Figure Name
11-2	Figure 11-1. W3 Hand-Held Control Head Exploded View
11-3	Figure 11-2. W4 Rotary Control Head Exploded View
11-4	Figure 11-3. W5 and W7 Pushbutton Control Head Exploded View
11-5	Figure 11-4. W9 Pushbutton Control Head Exploded View
11-6	Figure 11-5. XTL 5000 (3.5-35 W) Radio Exploded View
11-7	Figure 11-6. Motorcycle Interconnect Board and Assembly Exploded View
11-7	Figure 11-7. Interconnect Board and Assembly Exploded View
11-8	Figure 11-8. Motorcycle Radio Remote-Mount Control Head with Speaker and Microphone
11-9	Figure 11-9. Handlebar Installation (Control Head and Speaker Mounted Together) Exploded View
11-9	Figure 11-10. Handlebar Installation (Control Head and Speaker Mounted Separately) Exploded View
11-10	Figure 11-11. Fuel-Tank Console Installation (Control Head and Speaker Mounted Together) Exploded View
11-10	Figure 11-12. Fuel-Tank Console Installation (Control Head and Speaker Mounted Separately) Exploded View
11-11	Figure 11-13. HMN1062_ Motorcycle Microphone
11-11	Figure 11-14. HSN6003_ Motorcycle Weather-Resistant Speaker
11-12	Figure 11-15. Motorcycle Weather-Resistant Radio Enclosure
11-13	Figure 11-16. Motorcycle Universal Mounting Plate Exploded View

---

### 11.1 W3 Hand-Held Control Head Exploded View

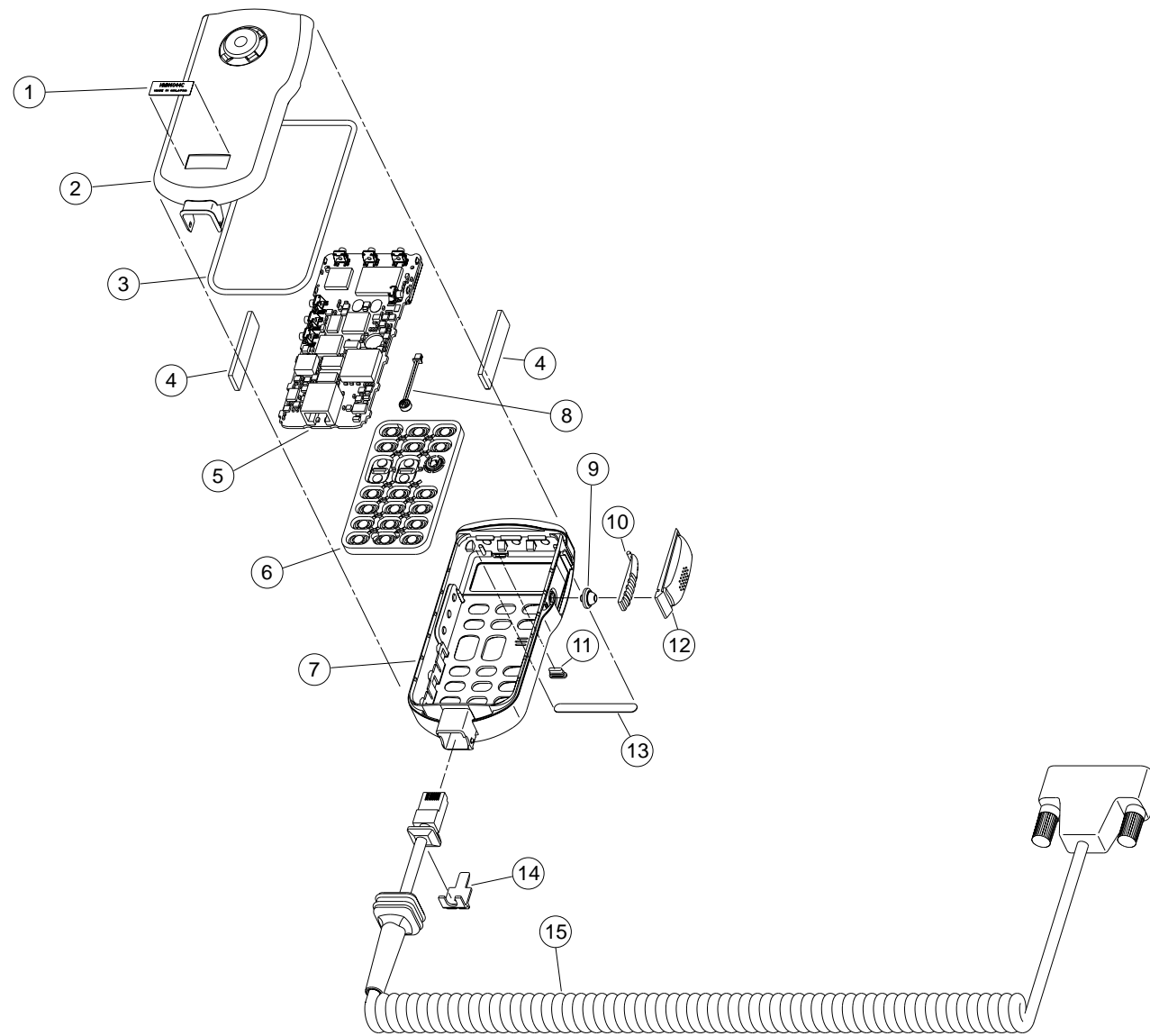


Figure 11-1. W3 Hand-Held Control Head Exploded View

Table 11-2. W3 Hand-Held Control Head Exploded View Parts List

Item No.	Motorola Part No.	Description
1	Not available	LABEL
2	0105955T26	ASSEMBLY, Rear Cover
3	3205082E93	SEAL, Main
4	4205343Y01	RETAINER, Snap (Qty 2)
5	0102707D81	BOARD, SB9600 Circuit
6	7505832X01	KEYPAD (Part of Item 7)
7	0102707D86	ASSEMBLY, Housing (Includes Items 6 and 9 thru 13)
8	0102708D08	ASSEMBLY, Microphone
9	7505618V02	ACTUATOR, PTT (Part of Item 7)
10	4505850X01	LEVER, PTT (Part of Item 7)
11	3205839X01	INDICATOR, Transmit (Part of Item 7)
12	3805835X01	BOOT, PTT (Part of Item 7)
13	3305409X17	LABEL (Part of Item 7)
14	3205274V01	WEDGE, Seal Support
15	HKN6095_	ASSEMBLY, Cable

**Note:** \_ = The latest version kit. When ordering, refer to your specific kit for this suffix letter.  
 Universal Crypto Module (UCM) part numbers and descriptions are listed in the Encryption chapter of this manual.

### 11.2 W4 Rotary Control Head Exploded View

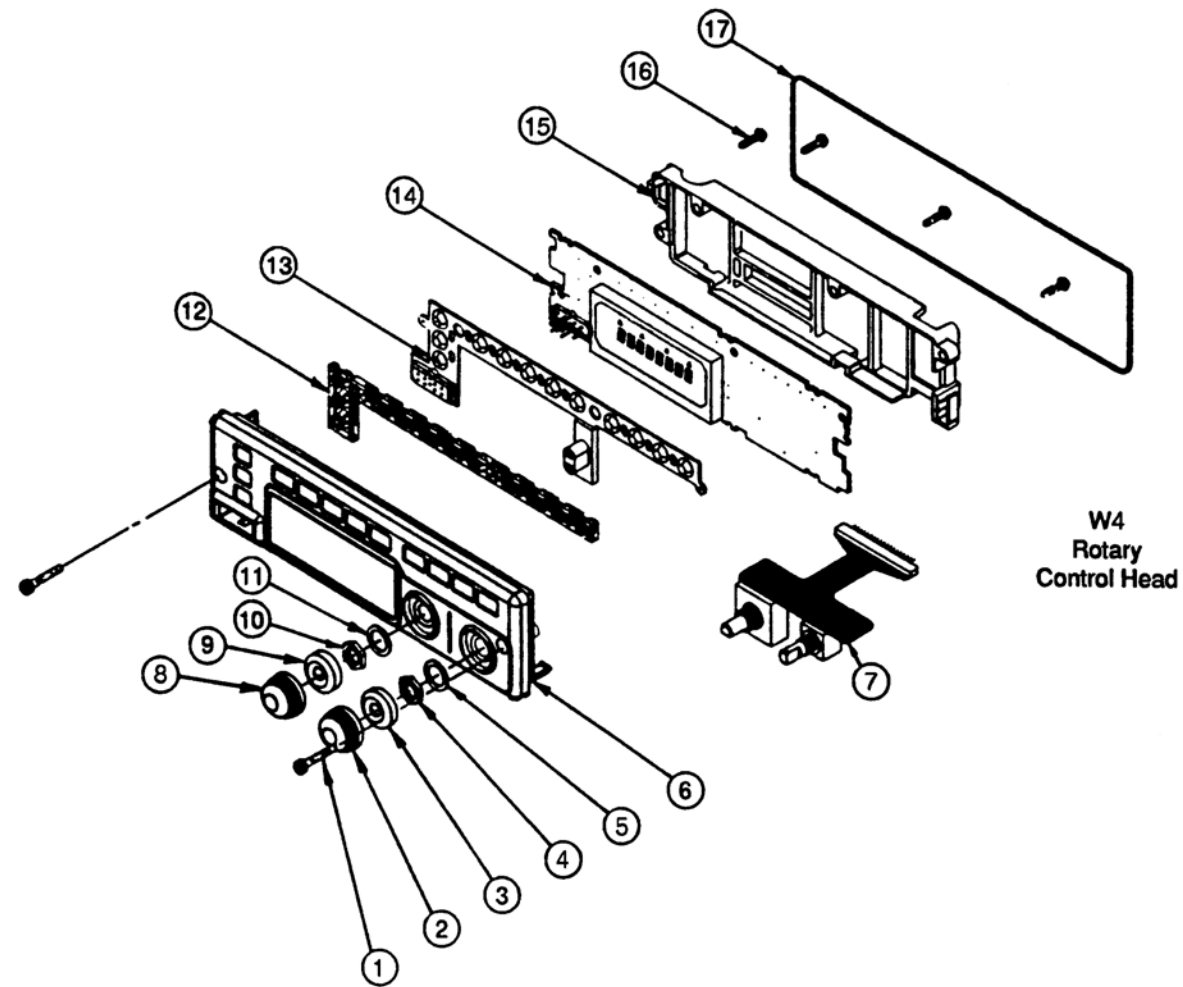


Figure 11-2. W4 Rotary Control Head Exploded View

Table 11-3. W4 Rotary Control Head Parts List

Item No.	Motorola Part No.	Description
1	0380077M07	SCREW, Control Head Mounting (Qty 2)
2	3602113Z05	KNOB, Volume Control
3	3205805V01	GASKET, W4 Shaft (Qty 2)
4	0284218M01	NUT, Volume Switch
5	0484219M01	LOCKWASHER, Volume Switch
6	1502117Z10 or 1502117Z11 or 1502117Z12	HOUSING, Front Cover (Mobile) HOUSING, Front Cover (Motorcycle) HOUSING, Front Cover (Rear)
7	0102709J83	ASSEMBLY, Volume and Rotary Switch
8	3602113Z03	KNOB, Mode Control
9	3205805V01	GASKET, W4 Shaft (Qty 2)
10	0284218M02	NUT, Mode Switch
11	0484219M02	LOCKWASHER, Mode Switch
12	6105129X01	LIGHTPIPE
13	7505128X01	KEYPAD
14	AAHN4045_ or PMLN4019_	ASSEMBLY, Circuit Board (Mobile) ASSEMBLY, Circuit Board (Motorcycle)
15	4302112Z02	SPACER, Internal
16	0310945A14	SCREW, Machine (Qty 4)
17	3280289L02	GASKET, Housing

**Notes:** \_ = The latest version kit. When ordering, refer to your specific kit for this suffix letter.  
 The HKN4356\_ Radio Cable is used to remote mount the W4 Control Head.  
 Universal Crypto Module (UCM) part numbers and descriptions are listed in the Encryption chapter of this manual.  
 The dash-mount flex (3085020F01) is used to connect the W4 control head to the transceiver.

### 11.3 W5 and W7 Pushbutton Control Head Exploded View

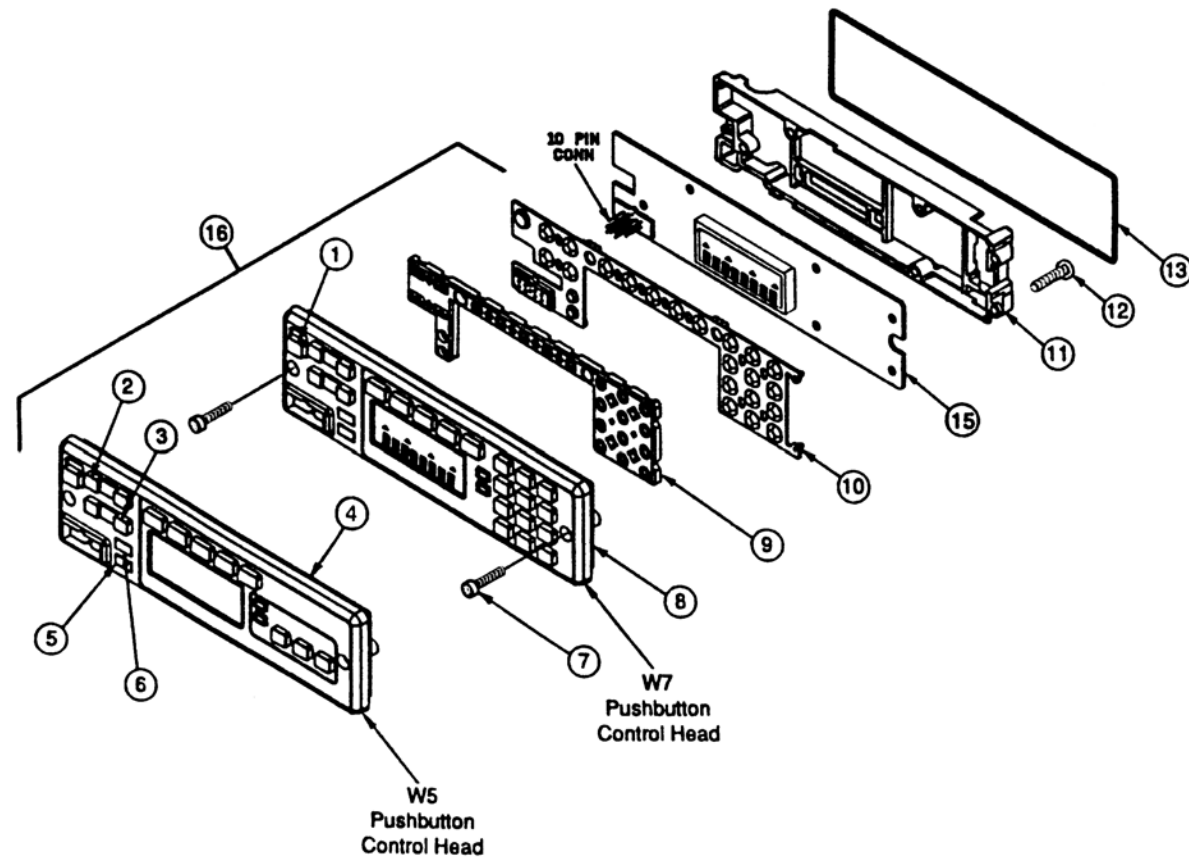


Figure 11-3. W5 and W7 Pushbutton Control Head Exploded View

Table 11-4. W5 and W7 Pushbutton Control Head Parts List

Item No.	Motorola Part No.	Description
1	3880227M04	SWITCH, On/Off Cap
2	3880009P01	SWITCH, Mode Rocker
3	3880009P02	SWITCH, Volume Rocker
4	1580020S23 or 1580020S25 or 1580020S27	HOUSING, W5 Front Cover (Mobile) HOUSING, W5 Front Cover (Motorcycle) HOUSING, W5 Front Cover (Rear)
5	3880092J05	PUSHBUTTON, HOME
6	3880092J05	PUSHBUTTON, DIM
7	0380077M07	SCREW, (Qty 2)
8	1580020S22 or 1580020S24 or 1580020S26	HOUSING, W7 Front Cover (Mobile) HOUSING, W7 Front Cover (Motorcycle) HOUSING, W7 Front Cover (Rear)
9	6180017S01	LIGHTPIPE
10	7580012S03	KEYPAD
11	4380019S02	SPACER, Internal Frame
12	0310945A14	SCREW, Tapping (Qty 7)
13	3280289L02	GASKET, Housing
15	HLN6396_ or HLN6563_	BOARD, Control Head (Mobile) BOARD, Control Head (Motorcycle)
16	0180049S13 or 0180049S15 or 0180049T16 0180049S12 or 0180049S14 or 0180049T15	ASSEMBLY, W5 Front Cover (Mobile) ASSEMBLY, W5 Front Cover (Motorcycle) ASSEMBLY, W5 Front Cover (Rear) ASSEMBLY, W7 Front Cover (Mobile) ASSEMBLY, W7 Front Cover (Motorcycle) ASSEMBLY, W7 Front Cover (Rear) Item 16 includes items 1, 2, 3, 4 or 8, 5, 6, 9, and 10

**Notes:** \_ = The latest version kit. When ordering, refer to your specific kit for this suffix letter.  
 The HKN4356\_ Radio Cable is used to remote mount the W5 and W7 Control Head.  
 Universal Crypto Module (UCM) part numbers and descriptions are listed in the Encryption chapter of this manual.  
 The dash-mount flex (3085020F01) is used to connect the W5 and W7 control heads to the transceiver.

### 11.4 W9 Pushbutton Control Head Exploded View

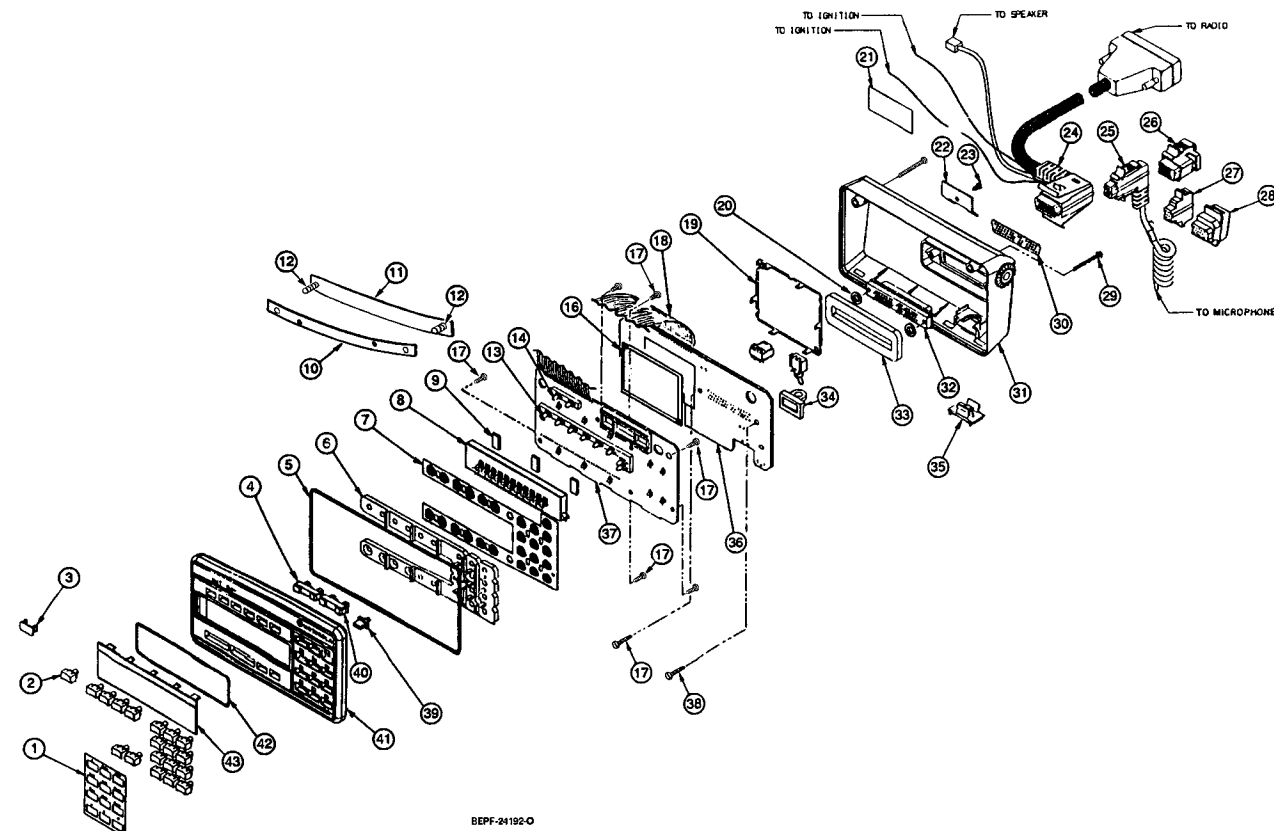


Figure 11-4. W9 Pushbutton Control Head Exploded View

Table 11-5. W9 Pushbutton Control Head Parts List

Item No.	Motorola Part No.	Description
1	1380087J01	ESCUTCHEON
2	HLN5083_	BUTTON, Emergency
	HLN5091_	BUTTON, Dir
	HLN5066_	BUTTON, Scan
	HLN5256_	BUTTON, Srch
	HLN5074_	BUTTON, Call
	HLN5268_	BUTTON, Page
	HLN5259_	BUTTON, RPGM
	HLN5258_	BUTTON, Site
	HLN5090_	BUTTON, PHON
	HLN5072_	BUTTON, H/L
	HLN5257_	BUTTON, Lock
	HLN5076_	BUTTON, RCL
	HLN5085_	BUTTON, SQL
	HLN5078_	BUTTON, Del
	HLN5087_	BUTTON, Home
	HLN5079_	BUTTON, Sel
	HLN5095_	BUTTON, Blank
3	3880253K04	PLUG
4	3880195P03	SWITCH, Mode Rocker
5	3205145X01	GASKET, Internal Frame
6	6105126X01	LIGHTPIPE, Keypad

Table 11-5. W9 Pushbutton Control Head Parts List (Continued)

Item No.	Motorola Part No.	Description
7	7505127X01	KEYPAD
8	7280242J01	DISPLAY, VF
9	7580094M05	PAD, Shock (Qty 3)
10	1405410X01	INSULATOR
11	4180042S01	SPRING, Leaf Assy
12	0380041S01	SCREW, Captive (Qty 4)
13	6180026R02	SPACER, LED (8-Position)
14	6180027R02	SPACER, LED (2-Position)
16	2680190P02	SHIELD, Solder Side (Includes two 1480269K01 insulators)
17	0310945A11	SCREW, Tapping (Qty 5)
18	3080034K01	CABLE, Flex
19	2680190P02	SHIELD, Component Side
20	3205082E90	O-RING "D" Connector (Qty 2)
21	3380178M01	NAMEPLATE
22	0784323C01	BRACKET, Strain Relief
23	0310908A18	SCREW, Machine
24	HKN4356_	CABLE, Radio
25	HMN1050_ or HMN1080_ or HMN1061_	KIT, Microphone
26	1580221J01	HOUSING, VIP Connector (Optional)
27	7502118Z01	COVER, Rubber Dust (MIC)
28	7502118Z02	COVER, Rubber Dust (VIP)
29	0310908A33	SCREW, Machine (Qty 2)
30	3205198X01	GASKET, Face
31	1505199X05	HOUSING, Back
32	2805778W01	CONNECTOR, Mini "D" 50 Contact
33	3205143X01	GASKET, "D" Connector
34	3205143X01	GASKET, On/Off Switch
35	3880128J01	KEY, On/Off
36	HCN4046_	BOARD KIT, Command (includes Display Board)
37	HCN4046_	BOARD KIT, Display (includes Command Board)
38	0310945A14	SCREW, Tapping (Qty 2)
39	3880092J05	KEY, Blank
40	3880195P02	SWITCH, Volume Rocker
41	1505125X12	HOUSING, Front
42	3205144X01	GASKET, Lens
43	6105146X01	LENS, VF Display

**Note:** \_ = The latest version kit. When ordering, refer to your specific kit for this suffix letter. Universal Crypto Module (UCM) part numbers and descriptions are listed in the Encryption chapter of this manual.

### 11.5 XTL 5000 (3.5-35 W) Radio Exploded View

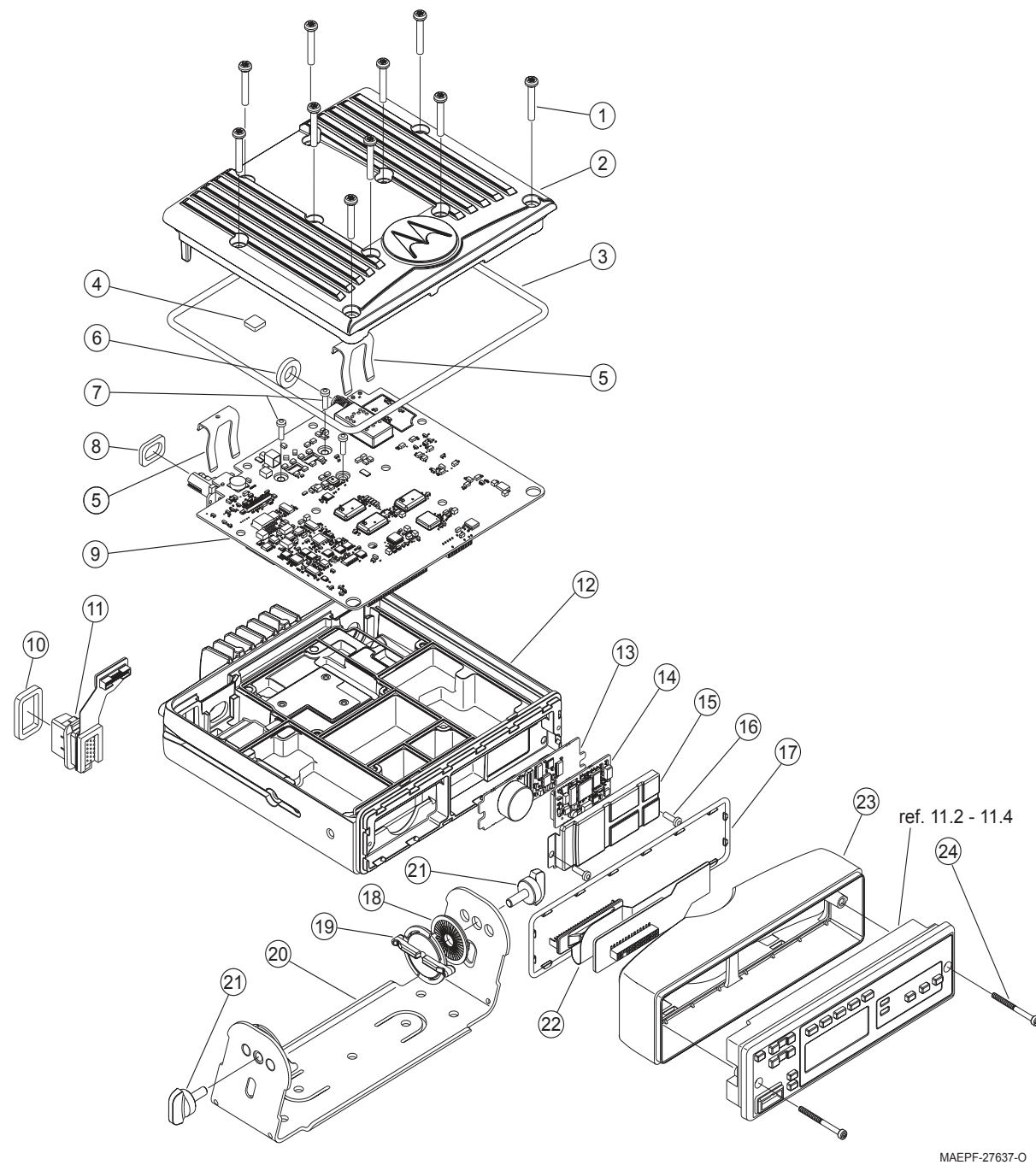


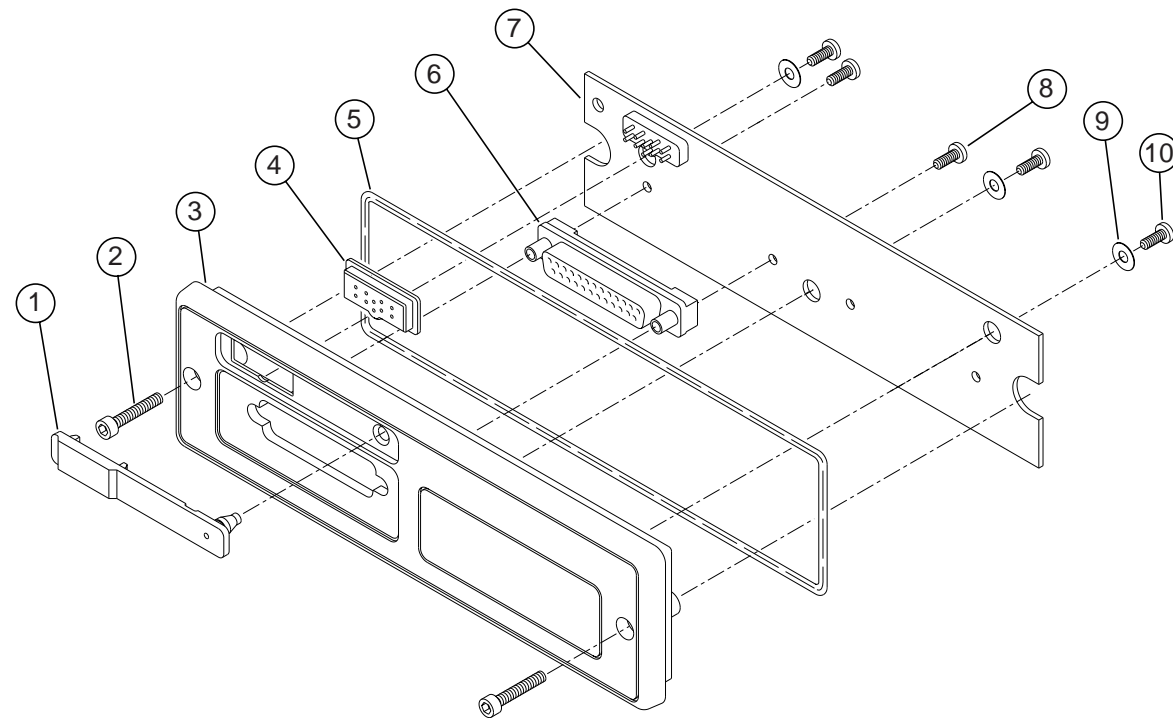
Figure 11-5. XTL 5000 (3.5-35 W) Radio Exploded View

Table 11-6. XTL 5000 (3.5-35W) Radio Parts List

Item No.	Motorola Part No.	Description
1	0385870E01	SCREW ASSEMBLY, TOP COVER
2	1585860C02	COVER, XTL 5000
3	3285495E01	SEAL, MAIN O-RING
4	7585060F01	PAD, THERMAL, GREY
5	4285702E01	CLIP, RF/DC RETENTION
6	3285743E01	SEAL, RF CONNECTOR
7	0310907A20	SCREW, M3X0.5X10 PAN-HEAD
8	3285744E01	SEAL, DC CONNECTOR
9	HUF4017_	PCB ASSEMBLY, MAIN (Includes Items 6 and 8)
10	3285742E01	SEAL, ACCESSORY
11	3085741E01	CONNECTOR, REAR ACCESSORY PORT
12	2785862C02	CHASSIS, XTL 5000 (See Table 8-2, "Chassis Thermal Pad Parts," on page 8-30 for thermal pad part numbers.)
13	HLN6876_ or HLN6877_	PCB ASSEMBLY, SECURE INTERFACE (3-DAY KEY RETENTION) PCB ASSEMBLY, SECURE INTERFACE (30- SECOND KEY RETENTION)
14	-----	MODULE, SECURE
15	2685498E01	SHIELD, SECURE
16	0310907A20	SCREW, M3X0.5X10, PAN-HEAD
17	3285471E01	SEAL, HEADBRIDGE
18	4305425W01	SPACER, INNER
19	4305426W03	SPACER, OUTER
20	HLN6861_	TRUNNION, XTL 5000 INCLUDES 18 (x2), 19 (x2), AND 21 (x2)
21	0305760W02	SCREW, M5.0X0.8X14.9 WING
22	3085020F01 or 3085019F01	FLEX, DASH MOUNT FLEX, REMOTE MOUNT
23	1585245E01	HOUSING, HEADBRIDGE
24	0380077M07	SCREW, CONTROL HEAD M3X35

**Note:** \_ = The latest version kit. When ordering, refer to your specific kit for this suffix letter.

### 11.6 Motorcycle Interconnect Board and Assembly



MAEPF-27661-O

Figure 11-6. Motorcycle Interconnect Board and Assembly Exploded View

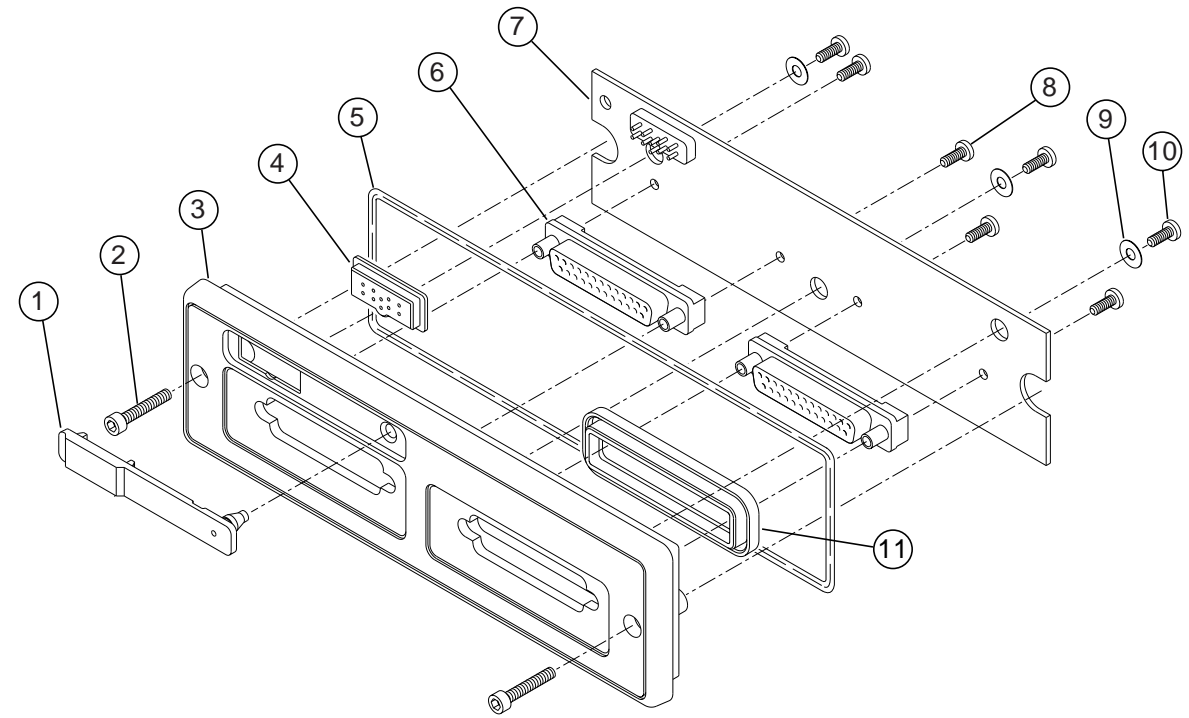
Table 11-7. Motorcycle Interconnect Board and Assembly Parts List

Item No.	Motorola Part No.	Description
1	3880064P01	CAP, DVP Connector
2	0380077M07	SCREW, Front Mount
3	1580062P12	HOUSING, Remote Front
4	3280063P01	GASKET, DVP Connector
5	3280289L02	GASKET, O-Ring
6	0980159P01	CONNECTOR, D-Sub
7	HLNxxxx_	BOARD, Interconnect (See dealer for applicable kit number.)
8	300139581	SCREW, Mach 4-40X5/16 P
9	400131974	WASHER, Flt.130.312
10	0310945A11	SCREW, Tapping P3.12X1.27X8

**Notes:** \_ = The latest version kit. When ordering, refer to your specific kit for this suffix letter.  
The remote-mount flex (P/N 3085019F01) is used to connect all interconnect assemblies to the transceiver.

### 11.7 Interconnect Board and Assembly

This illustration (Figure 11-7) represents the interconnect board for all control heads, except the motorcycle.



MAEPF-27662-O

Figure 11-7. Interconnect Board and Assembly Exploded View

Table 11-8. Interconnect Board and Assembly Parts List

Item No.	Motorola Part No.	Description
1	3880064P01	CAP, DVP Connector
2	0380077M07	SCREW, Front Mount
3	1580062P11	HOUSING, Remote Front
4	3280063P01	GASKET, DVP Connector
5	3280289L02	GASKET, O-Ring
6	0980159P01	CONNECTOR, D-Sub
7	HLNxxxx_	BOARD, Interconnect (See dealer for applicable kit number.)
8	300139581	SCREW, Mach 4-40X5/16 P
9	400131974	WASHER, Flt.130.312
10	0310945A11	SCREW, Tapping P3.12X1.27X8
11	3280025R01	GASKET, Remote
Not shown	1580005G01*	COVER, Dust

**Notes:** \_ = The latest version kit. When ordering, refer to your specific kit for this suffix letter.  
\* = Used when the option cable is not used or when the radio is stowed.  
The remote-mount flex (P/N 3085019F01) is used to connect all interconnect assemblies to the transceiver.

### 11.8 Motorcycle Radio Remote-Mount Control Head with Speaker and Microphone

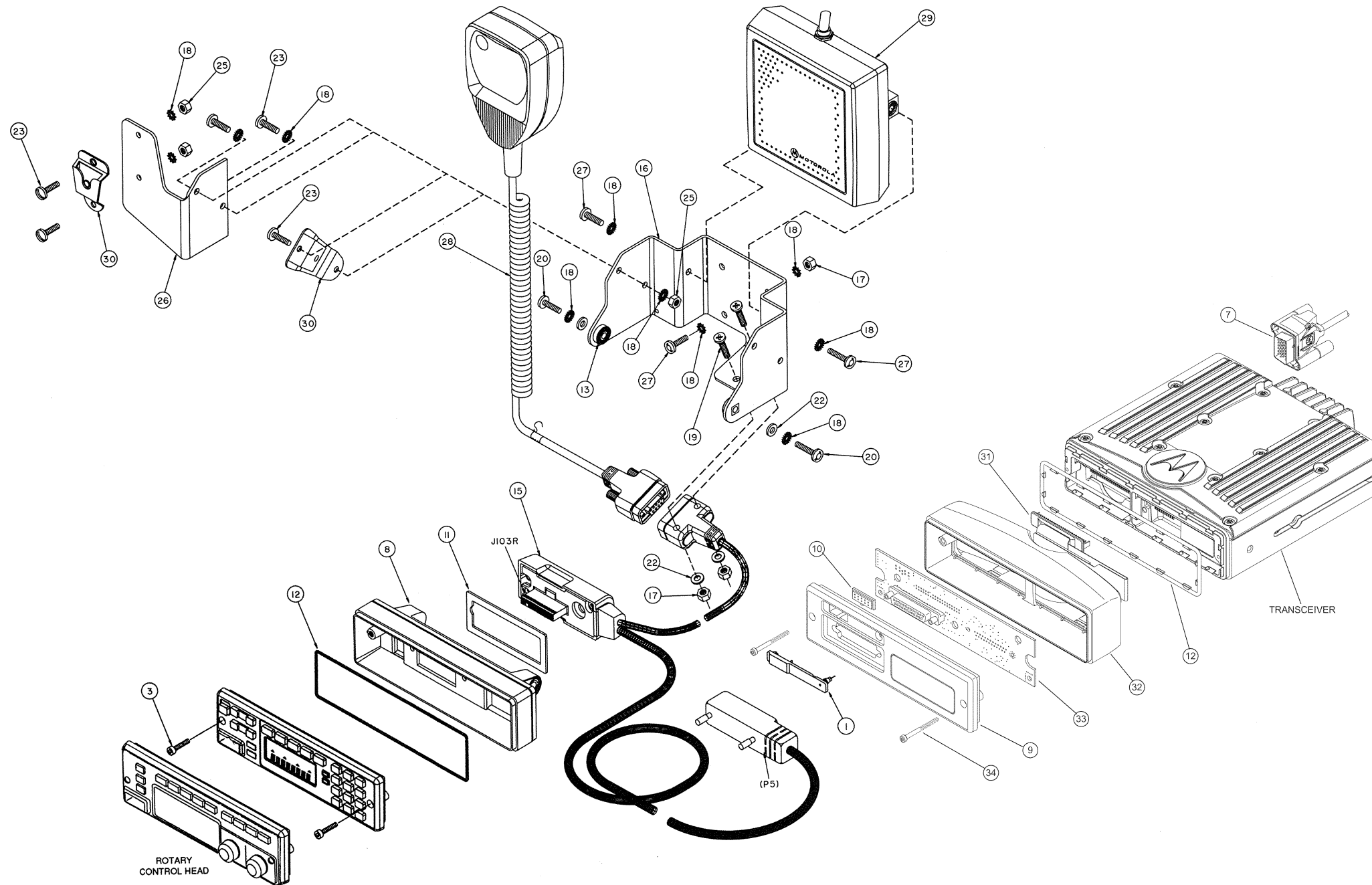


Table 11-9. Motorcycle Radio Remote-Mount Control Head with Speaker and Microphone Parts List

Item No.	Motorola Part No.	Description
-	See Model Chart	Motorcycle hardware kit SECURENET
-	See Model chart	Motorcycle hardware kit
1	38-80064P01	Cap, SECURENET connector
3	03-80077M01	Screw, front-mount (4 used)
7	HLN6890_	Cable, accessory, motorcycle
8	15-80293L03	Housing, back remote rework
9	15-80062P12	Housing, front remote SECURENET
10	32-80063P02	Gasket, SECURENET
11	32-80231M01	Gasket
12	32-80289L02	Gasket, housing
13	43-80128N01	Spacer, trunnion (2 used)
14	32-85471E01	Seal, headbridge
15	See Model Chart	Control-head cable, 22-conductor
16	07-80200P01	Bracket, control-head/speaker-mounting
17	02-05681N03	Nut, hex, M5 x 0.8-6H x 8.87 (6 used)
18	04-00002647	Lockwasher #10 ext (14 used)
19	03-80114M05	Screw, machine, M5 x 0.8 x 30 mm (2 used)
20	03-80114M04	Screw, machine, M5 x 0.8 x 16 mm (2 used)
22	04-00128991	Washer, 0.234 x 0.5 x 0.048 (4 used)
23	03-07644M19	Screw, machine, 8-32 x 7/16 (4 used)
25	02-00001355	Nut, hex, 8-32 x 5/16 x 1/8 (4 used)
26	07-80201P01	Bracket, extension
27	03-80114M03	Screw, machine, M5 x 0.8 x 12 mm (2 used)
28	See Model Chart	Microphone and coiled cord
29	-	Speaker (see Figure 11-14 on page 11-11)
30	01-80743T91	Spring and bracket eyelet (HLN5391A)
31	30-86019F01	Remote flex
32	15-85245E01	Housing, headbridge
33	HLN6884_	Motorcycle interconnect board
34	03-80077M07	Screw, control-head, M3 x 35 mm
<b>Non-Referenced Parts</b>		
	03-12002A01	Screw, self-drilling (2 used)
	03-12002C01	Screw, self-drilling*
	07-80357N01	Back-up plate*
	01-80750T52	DC grounding wire
	29-00824456	Lug*
	07-80127N02	Trunnion, remote**

**Note:**

\_ = The latest version kit. When ordering, refer to your specific kit for this suffix letter.

\* = These parts are provided in the hang-up clip for mounting the hang-up clip on surfaces that are not metallic and/or are not grounded to the motorcycle chassis.

\*\* = Used to mount the control head when the speaker and control head are mounted separately.

Figure 11-8. Motorcycle Radio Remote-Mount Control Head with Speaker and Microphone



### 11.9 Handlebar Installation (Control Head and Speaker Mounted Together)

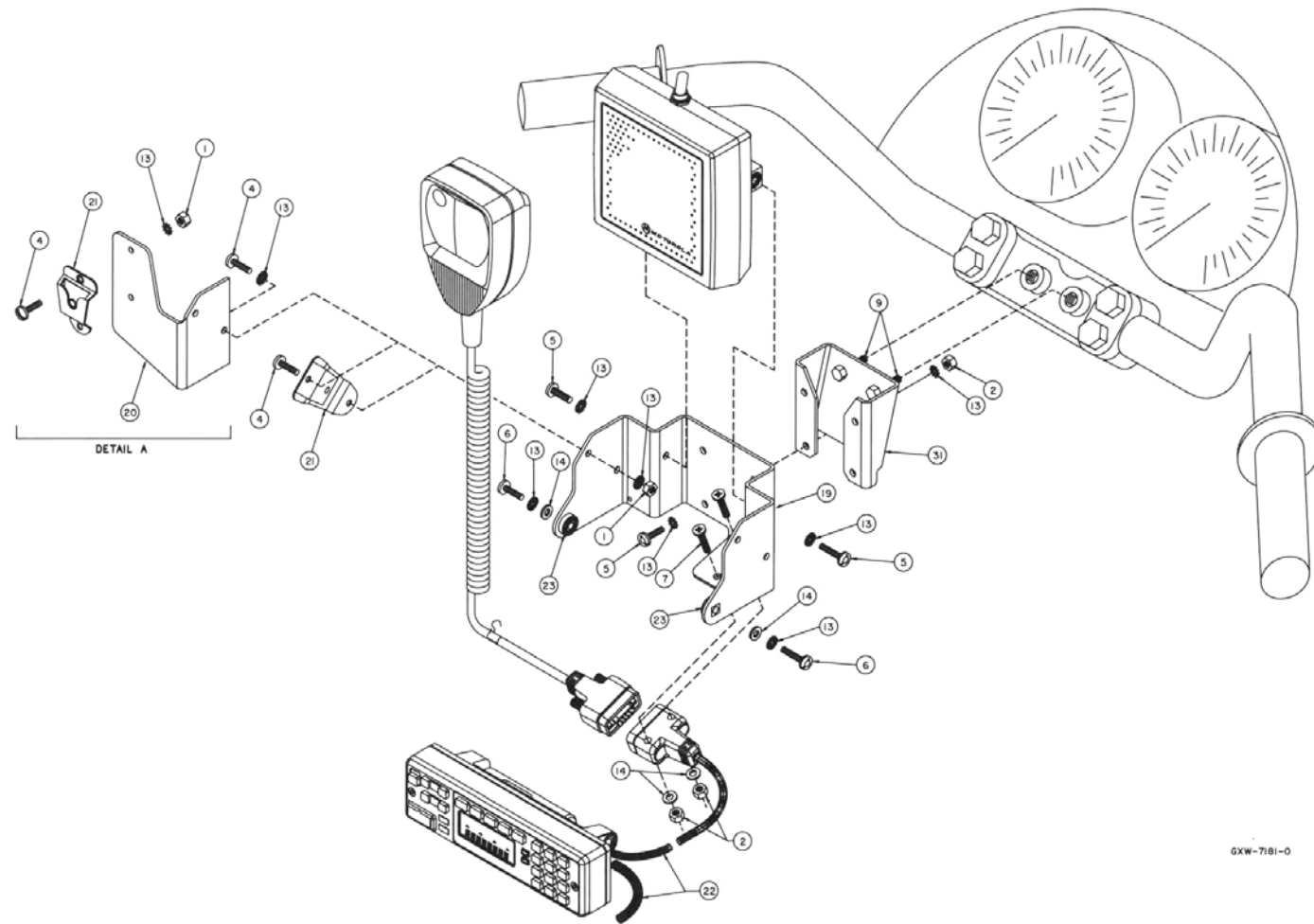


Figure 11-9. Handlebar Installation (Control Head and Speaker Mounted Together) Exploded View

Table 11-10. Handlebar Installation (Control Head and Speaker Mounted Together) Parts List

Item No.	Motorola Part No.	Description	Item No.	Motorola Part No.	Description
1	0200001355	Nut, hex, 8-32 x 5/16 x 1/8 (4 used)	19	0780200P01	Bracket, control head/speaker
2	0205681N03	Nut, hex, M5 x 0.8-6H 8.87 (6 used)	20	0780201P01	Bracket, mic extension
4	0307644M19	Screw, 8-32 x 7/16 (4 used)	21**	0180743T91	Eyelet, spring & bracket
5	0380114M03	Screw, M5 x 0.8 x 12 (6 used)	22	See model charts	Cable, control head
6	0380114M04	Screw, M5 x 0.8 x 16 (2 used)	23	4380128N01	Spacer, trunnion (4 used)
7	0380114M05	Screw, M5 x 0.8 x 30 (2 used)		See model charts	Hardware kit, motorcycle
9*		Screw, M8 (2 used)		See model charts	Adapter kit, control head/speaker, incl:
13	0400002647	Lockwasher, #10 ext. tooth (19 used)	31	0780041R01	Bracket, mounting, handlebar
14	0400128991	Washer, flat 0.234 x 0.5 x 0.048 (4 used)			

\* This is a customer-supplied part.

\*\* These parts are provided in the hang-up clip for mounting the hang-up clip on surfaces that are not metallic and/or are not grounded to the motorcycle chassis.

### 11.10 Handlebar Installation (Control Head and Speaker Mounted Separately)

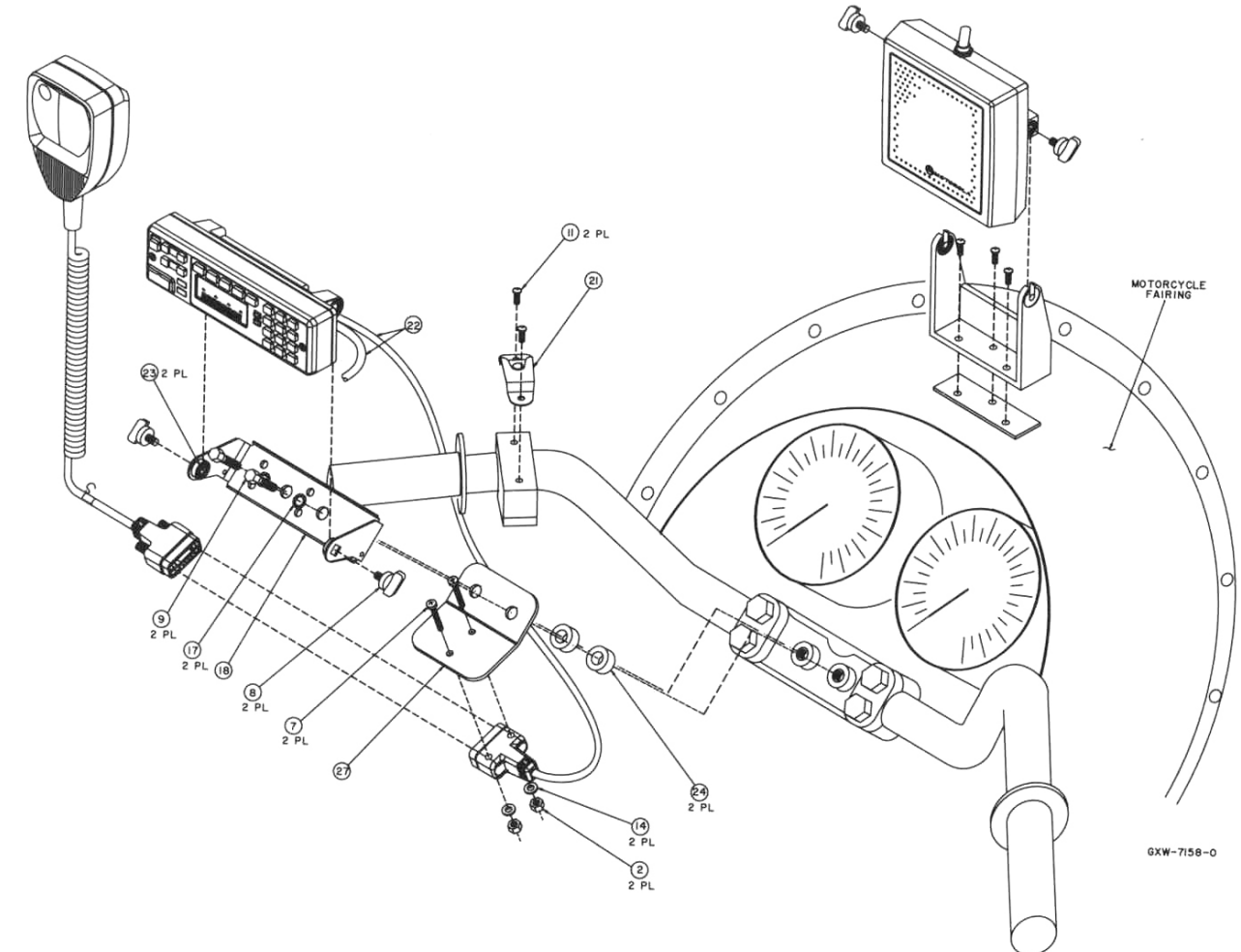


Figure 11-10. Handlebar Installation (Control Head and Speaker Mounted Separately) Exploded View

Table 11-11. Handlebar Installation (Control Head and Speaker Mounted Separately) Parts List

Item No.	Motorola Part No.	Description	Item No.	Motorola Part No.	Description
2	0205681N03	Nut, hex, M5 x 0.8-6H 8.87 (6 used)	21**	0180743T91	Eyelet, spring & bracket
7	0380114M05	Screw, M5 x 0.8 x 30 (2 used)	22	See model charts	Cable, control head
8	0384244C06	Screw, wing, black (4 used)	23	4380128N01	Spacer, trunnion (4 used)
9*		Screw, M8 (2 used)		See model charts	Hardware kit, motorcycle
11**	0312002A01	Screw, self-drilling (2 used)		See model charts	Adapter kit, control head/speaker, incl:
14	0400128991	Washer, flat 0.234 x 0.5 x 0.048 (4 used)	24	4380042R01	Spacer, bushing (2 used)
17*		Lockwasher, M8, ext. tooth (2 used)	27	0780046R01	Bracket, mic cable
18	0780127N01	Trunnion, remote mount			

\* This is a customer-supplied part.

\*\* These parts are provided in the hang-up clip for mounting the hang-up clip on surfaces that are not metallic and/or are not grounded to the motorcycle chassis.

11.11 Fuel-Tank Console Installation (Control Head and Speaker Mounted Together)

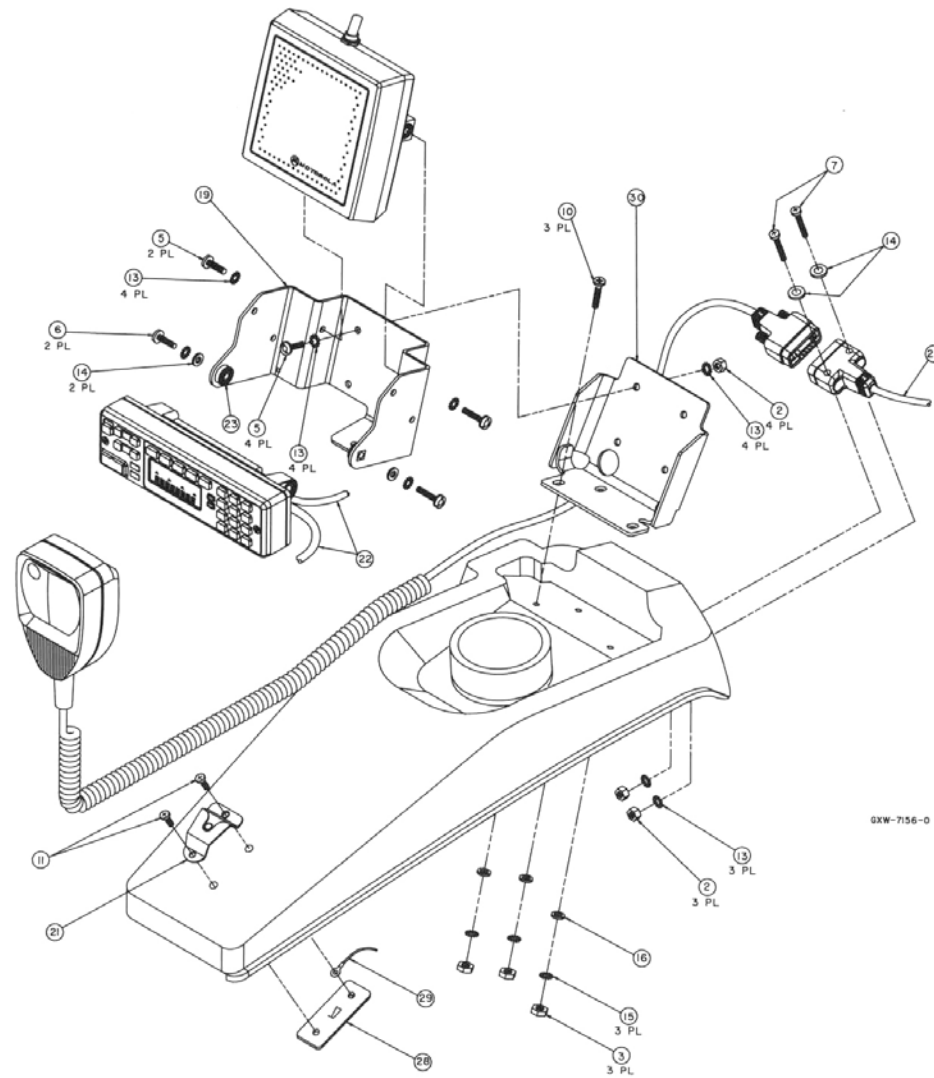


Figure 11-11. Fuel-Tank Console Installation (Control Head and Speaker Mounted Together) Exploded View

Table 11-12. Fuel-Tank Console Installation (Control Head and Speaker Mounted Together) Parts List

Item No.	Motorola Part No.	Description	Item No.	Motorola Part No.	Description
2	0205681N03	Nut, hex, M5 x 0.8-6H 8.87 (6 used)	23	4380128N01	Spacer, trunnion (4 used)
5	0380114M03	Screw, M5 x 0.8 x 12 (6 used)	28*	0780257N01	Plate, backup
6	0380114M04	Screw, M5 x 0.8 x 16 (2 used)	29*	0180750T52	Grounding wire, DC
7	0380114M05	Screw, M5 x 0.8 x 30 (2 used)		See model charts	Hardware kit, motorcycle
11*	0312002A01	Screw, self-drilling (2 used)		See model charts	Adapter kit, control head/speaker, incl:
13	0400002647	Lockwasher, #10 ext. tooth (19 used)	3	0200009644	Nut, 1/4-20 x 7/16 x 3/16 (3 used)
14	0400128991	Washer, flat 0.234 x 0.5 x 0.048 (4 used)	10	0300001908	Screw, machine, 114-20 x 3/4 (3 used)
19	0780200P01	Bracket, control head/speaker	15	0400139951	Lockwasher, 114 (3 used)
21*	0180743T91	Eyelet, spring & bracket	16	0400136592	Washer, flat, 1/4 (3 used)
22	See model charts	Cable, control head	30	0780028R01	Bracket, mounting

\* These parts are provided in the hang-up clip for mounting the hang-up clip on surfaces that are not metallic and/or are not grounded to the motorcycle chassis.

11.12 Fuel-Tank Console Installation (Control Head and Speaker Mounted Separately)

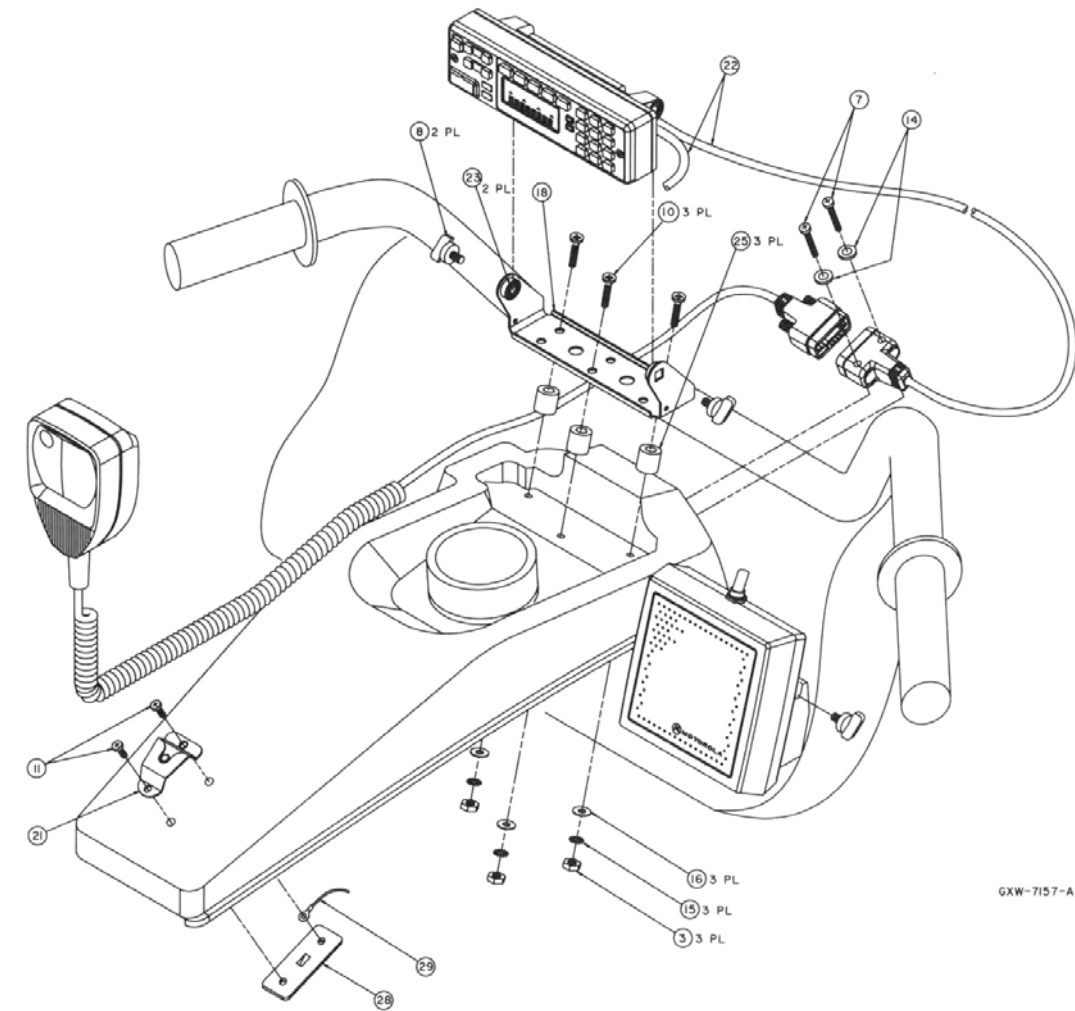


Figure 11-12. Fuel-Tank Console Installation (Control Head and Speaker Mounted Separately) Exploded View

Table 11-13. Fuel-Tank Console Installation (Control Head and Speaker Mounted Separately) Parts List

Item No.	Motorola Part No.	Description	Item No.	Motorola Part No.	Description
7	0380114M05	Screw, M5 x 0.8 x 30 (2 used)	29*	0180750T52	Grounding wire, DC
8	0384244C06	Screw, wing, black (4 used)		See model charts	Hardware kit, motorcycle
11*	0312002A01	Screw, self-drilling (2 used)		See model charts	Adapter kit, control head/speaker, incl:
14	0400128991	Washer, flat 0.234 x 0.5 x 0.048 (4 used)	3	0200009644	Nut, 1/4-20 x 7/16 x 3/16 (3 used)
18	0780127N01	Trunnion, remote mount	10	0300001908	Screw, machine, 114-20 x 3/4 (3 used)
21*	0180743T91	Eyelet, spring & bracket	15	0400139951	Lockwasher, 114 (3 used)
22	See model charts	Cable, control head	16	0400136592	Washer, flat, 1/4 (3 used)
23	4380128N01	Spacer, trunnion (4 used)	25	4380042R02	Spacer, bushing (3 used)
28*	0780257N01	Plate, backup	32		Screw

\* These parts are provided in the hang-up clip for mounting the hang-up clip on surfaces that are not metallic and/or are not grounded to the motorcycle chassis.

### 11.13 HMN1062\_ Motorcycle Microphone

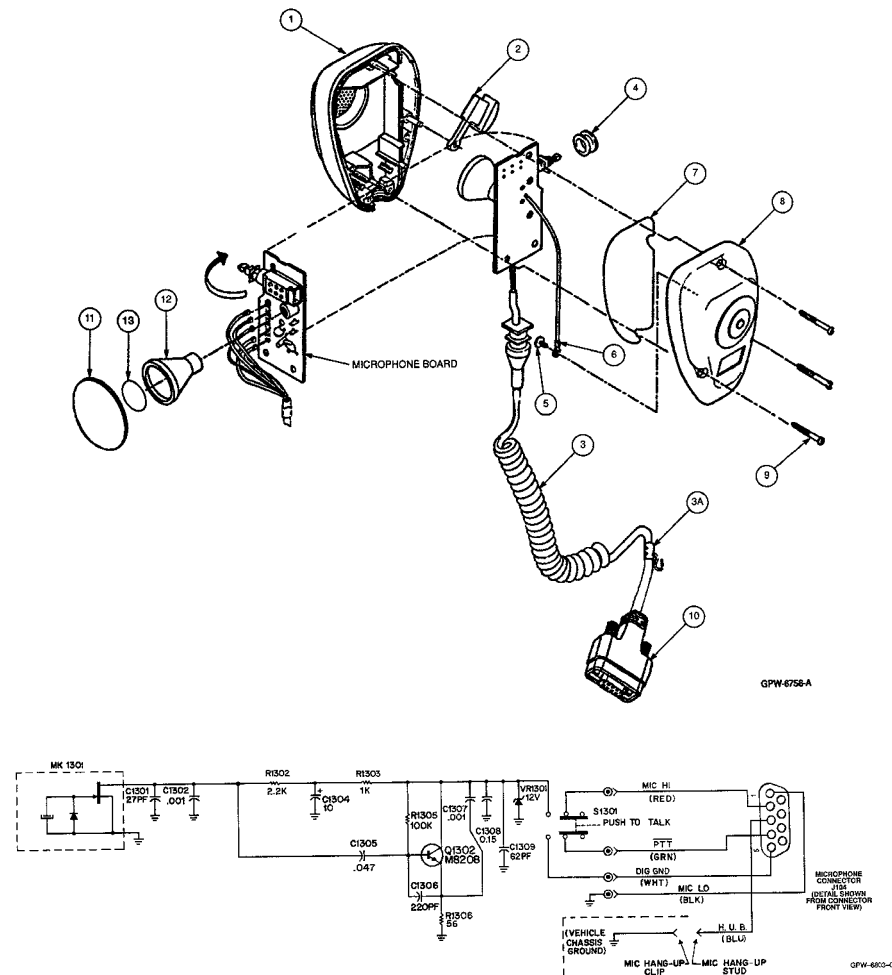


Figure 11-13. HMN1062\_ Motorcycle Microphone

Table 11-14. HMN1062\_ Motorcycle Microphone Parts List

Item No.	Motorola Part No.	Description
	HLN5459_	Microphone PC board (see Detailed Service Manual)
	See Model Chart	Hardware kit, motorcycle
1	15-00335M01	Front housing, microphone
2	38-80144D03	Button, microphone PTT
3	30-80144D03	Cable, coiled, includes:
3A	42-84061A03	Clamp, wire
4	05-80221K01	Grommet, PTT switch
5	03-10943M09	Screw, tapping, TT3 x 0.5 x 8
6	30-80206L01	Wire, PC board to weight
7	32-80058H03	Gasket, housing
8	01-80750T91	Rear housing, microphone
9	03-80076E04	Screw, metric H-LO (3 used)
10	09-80218J01	Receptacle, microphone
11	35-00008M02	Membrane
12	05-80148D01	Grommet, microphone cartridge
13	35-80089D01	Microphone felt

### 11.14 HSN6003\_ Motorcycle Weather-Resistant Speaker

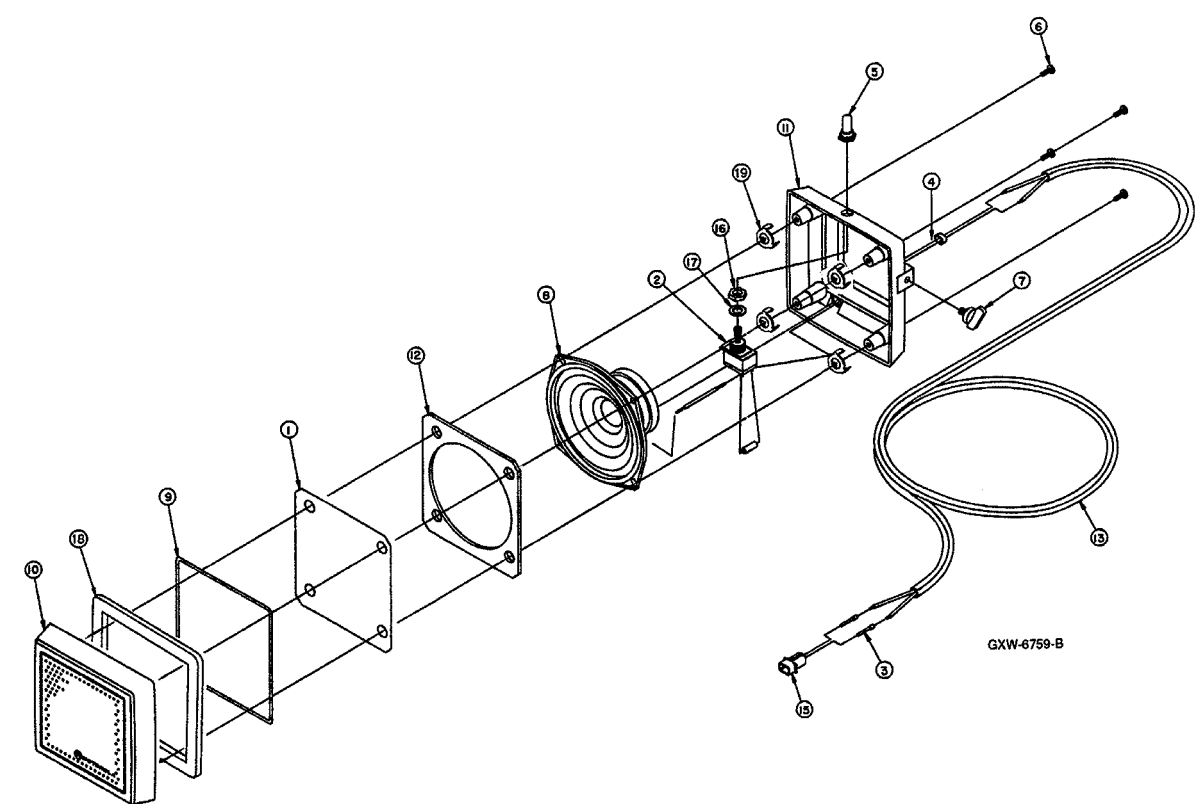


Figure 11-14. HSN6003\_ Motorcycle Weather-Resistant Speaker

Table 11-15. HSN6003\_ Motorcycle Weather-Resistant Speaker Parts List

Item No.	Motorola Part No.	Description
1	35-06850K01	Cloth grille
2	40-83477E03	Switch, toggle, SPST
3	39-10184A45	Contact, plug (2 used)
4	42-82018H05	Cable retainer
5	32-06682F01	Seal, toggle switch
6	03-00140001	Screw, tapping, 6-19 x 7/8
7	03-84244C06	Screw, wing, black shadow
8	50-84561B08	Speaker, 5-inch, 30 W
9	32-00046M04	Gasket
10	13-00133M05	Bezel
11	15-80099R02	Housing, speaker, weather-resistant
12	32-06849K01	Gasket
13	30-83155H01	Cable, 2-conductor
15	15-10183A18	Housing, connector, 2-contact
16	40-83477E03	Nut
17	04-00001757	Washer
18	32-80000S01	Gasket, speaker
19	04-80299R01	Capsert (4 used)
<b>Non-Referenced Parts</b>		
	06-11086A27	Resistor, 47 ohm, ±5%, 1 W
	07-80200E01	Trunnion bracket, speaker (not shown)
	03-12002B14	Screw, self-drilling, 10-16 x 1 (3 used)

### 11.15 Motorcycle Weather-Resistant Radio Enclosure

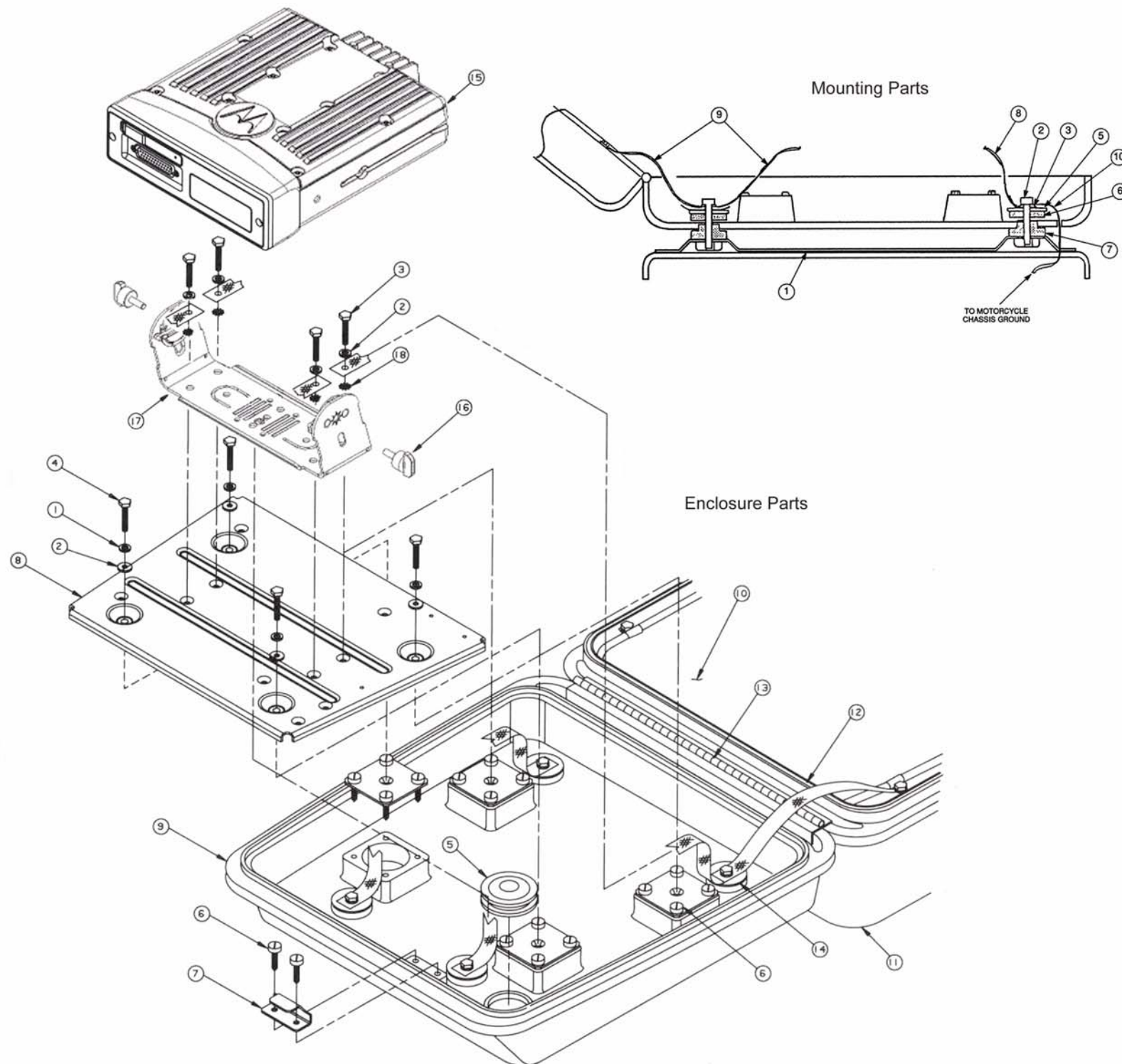


Figure 11-15. Motorcycle Weather-Resistant Radio Enclosure

Table 11-16. Motorcycle Weather-Resistant Radio Enclosure Parts List (Enclosure Parts)

Item No.	Motorola Part No.	Description
1	04-84336M02	Lockwasher (4 used)
2	04-84338M01	Washer, flat (8 used)
3	03-84208M16	Screw (4 used)
4	03-84208M16	Screw (4 used)
5	05-00005M01	Grommet, large hole
6	03-00007467	Screw, 8-18 x 3/8 (18 used)
7	55-83818F01	Catch, lock
8	64-82734P02	Plate, mounting, radio
9	See Model Chart	Housing, rework, bottom
-	64-00245M01	Adapter (4 used)
10	26-80066R01	Shield, grounding plane
11	See Model Chart	Housing, top cover
12	32-00042M01	Gasket
-	42-10128A05	Ring, retaining
-	45-83015P01	Cam, lock
-	55-83817F01	Lock
13	55-83079P01	Hinge
-	05-10344A09	Rivet (10 used)
14	-	Enclosure mounting hardware (see Table 11-13 below)
15	-	Transceiver
16	03-84244C06	Screw, wing (2 used)
17	HLN6861_	Trunnion
18	04-00002647	Lockwasher, external tooth (6 used)
<b>Non-Referenced Parts (from HLN6168B and HLN6169B)</b>		
	03-80077M01	Screw, hex socket
<b>Non-Referenced Parts (from HLN6180B)</b>		
	42-10217A29	Tie strap, 140" x 11" (10 used)

Table 11-17. Motorcycle Weather-Resistant Radio Enclosure Parts List (Mounting Parts)

Item No.	Motorola Part No.	Description
1	6483673F02	Universal mounting plate
2	0300034M03	Screw, machine M6 x 1 x 30 (4 used)
3	0400136658	Lockwasher (4 used)
5	0483416P01	Washer, flat (4 used)
6	7500025M02	Rubber washer, flat
7	7500025M01	Rubber washer, shoulder
8	3000046M01	Ground strap, 4-1/2" lg (2 used)
9	3000047M01	Ground strap, 7-1/2" lg (3 used)
10	3000047M03	Strap, ground (1 used)

### 11.16 Motorcycle Universal Mounting Plate

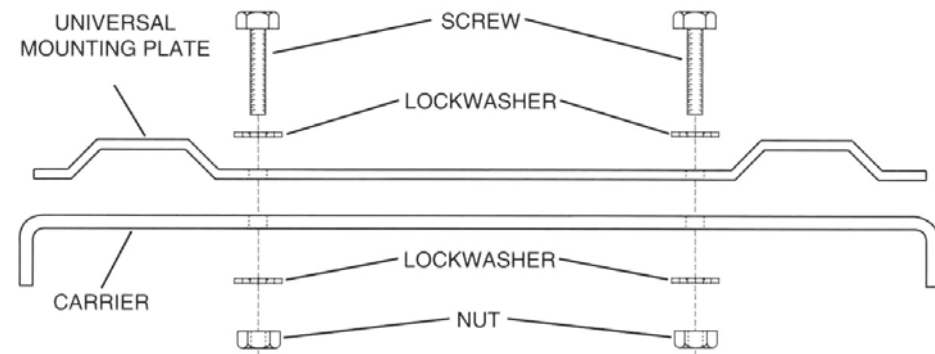


Figure 11-16. Motorcycle Universal Mounting Plate Exploded View

Table 11-18. Motorcycle Universal Mounting Plate Parts List

Motorola Part No.	Description
0200009644	Nut
0300001908	Screw
0400139951	Lockwasher
6483673F02	Mounting plate, universal

### 11.17 Small Pushbutton Parts

Table 11-19. Small Pushbutton Parts List

Part Number	Graphic Legend	Part Number	Graphic Legend
3805671X02	1	3805671X21	9wxy
3805671X03	2	3805671X22	* Rcl
3805671X04	3	3805671X23	#Del
3805671X05	4	3805671X24	1Ste
3805671X06	5	3805671X25	2Pge
3805671X07	6	3805671X26	3Lck
3805671X08	7	3805671X27	4Sts
3805671X09	8	3805671X28	5Rpg
3805671X10	9	3805671X29	6Msg
3805671X11	0	3805671X30	7H/L
3805671X12	*	3805671X31	8Mon
3805671X13	#	3805671X32	9Dir
3805671X14	2abc	3805671X33	Mon
3805671X15	3def	3805671X34	H/L
3805671X16	4ghi	3805671X35	DIR
3805671X17	5jkl	3805671X36	Urg
3805671X18	6mno	3805671X37	RTT
3805671X19	7prs	3805671X38	Home
3805671X20	8tuv	3805671X39	Dim

### 11.18 Large Pushbutton Parts

Table 11-20. Large Pushbutton Parts List

Part Number	Graphic Legend	Part Number	Graphic Legend
3805672X01	--	3805672X10	H/L
3805672X02	MPL	3805672X11	Sts
3805672X03	Scan	3805672X12	Call
3805672X04	DVP	3805672X13	Msg
3805672X05	PA	3805672X14	Rcl
3805672X06	Sirn	3805672X15	Mode
3805672X07	Wail	3805672X16	ExRd
3805672X08	Hi/Lo	3805672X17	Del
3805672X09	Man	3805672X18	Sel
3805672X19	Mon	3805672X52	Emer
3805672X20	DTMF	3805672X53	Stdy
3805672X21	Yelp	3805672X54	ECC
3805672X22	MVS	3805672X55	Rptr
3805672X23	Play	3805672X56	State
3805672X24	Rply	3805672X57	Reg
3805672X25	Rcrd	3805672X58	AirHn
3805672X26	Emer	3805672X59	TB Scn
3805672X27	Ext	3805672X60	SCC
3805672X28	F/R	3805672X61	Srch
3805672X29	Alt	3805672X62	Lock
3805672X30	Tel	3805672X63	Page
3805672X31	SqL	3805672X64	Rear
3805672X32	DES	3805672X65	Xfer
3805672X33	Txt	3805672X66	ST
3805672X34	Indv	3805672X67	VHF
3805672X35	Pvt	3805672X68	UHF
3805672X36	Site	3805672X69	Aux
3805672X37	AA	3805672X70	QC II
3805672X38	Sub	3805672X71	Mute
3805672X39	Home	3805672X72	Pri
3805672X40	Menu	3805672X73	Blu

Table 11-20. Large Pushbutton Parts List (Continued)

Part Number	Graphic Legend	Part Number	Graphic Legend
3805672X41	Rpgm	3805672X74	Div
3805672X42	Step	3805672X75	RTT
3805672X43		3805672X76	Send
3805672X44	Phon	3805672X77	Front
3805672X45	Dir	3805672X78	Bid
3805672X46	Text	3805672X79	ZONE
3805672X47	Rvw	3805672X80	TRBL
3805672X48	Sec	3805672X81	OVHD
3805672X49	Ø	3805672X82	UNGD
3805672X50	L/S	3805672X83	RSSI
3805672X51	S/S	3805672X84	VRS
3805672X85	A/B	3805669X12	ETrp
3805672X86	Chan	3805669X13	LvTe
3805672X87	PRTT	3805669X14	ArTe
3805672X88	RtRn	3805669X15	LvGg
3805672X89	Emp#	3805669X16	ArGg
3805672X90	Pass	3805669X17	P/in
3805672X91	Cir	3805669X18	P/out
3805672X92	URG	3805669X19	Serv
3805672X93	A	3805669X20	O/S
3805672X94	B	3805669X21	Rev
3805672X95	C	3805669X22	Stby
3805672X96	D	3805669X23	Sts 1
3805672X97	E	3805669X24	Sts 2
3805672X98	F	3805669X25	Sts 3
3805672X99	G	3805669X26	Sts 4
3805669X01	K	3805669X27	Sts 5
3805669X02	L	3805669X28	Sts 6
3805669X03	T/Z	3805669X29	Sts 7
3805669X04	30	3805669X30	Sts 8
3805669X05	Entr	3805669X31	Drv
3805669X06	M/WT	3805669X32	Bdg#
3805669X07	MAck	3805669X33	LnBl
3805669X08	Time	3805669X34	RtBl

Table 11-20. Large Pushbutton Parts List (Continued)

Part Number	Graphic Legend	Part Number	Graphic Legend
3805669X09	SRun	3805669X35	LnRn
3805669X10	ERun	3805669X36	s
3805669X11	STrp	3805669X37	t

## Notes

---

# Appendix A Replacement Parts Ordering

## A.1 Basic Ordering Information

When ordering replacement parts or equipment information, the complete identification number should be included. This applies to all components, kits, and chassis. If the component part number is not known, the order should include the number of the chassis or kit of which it is a part, and sufficient description of the desired component to identify it.

Crystal orders should specify the crystal type number, crystal and carrier frequency, and the model number in which the part is used.

## A.2 Motorola Online

Motorola Online users can access our online catalog at

<https://www.motorola.com/businessonline>

To register for online access, please call 800-814-0601 (for U.S. and Canada Service Centers only). International customers can obtain assistance at <https://businessonline.motorola.com>.

## A.3 Mail Orders

Send written orders to the following addresses:

**Replacement Parts/  
Test Equipment/Manuals/  
Crystal Service Items:**

Motorola Inc.  
Radio Products Services Division\*  
Attention: Order Processing  
1307 E. Algonquin Road  
Schaumburg, IL 60196  
U.S.A.

**Federal Government Orders:**

Motorola Inc.  
U.S. Federal Government  
Markets Division  
Attention: Order Processing  
7230 Parkway Drive  
Landover, MD 21076  
U.S.A.

**International Orders:**

Motorola Inc.  
Radio Products Services Division\*  
Attention: Order Processing  
1307 E. Algonquin Road  
Schaumburg, IL 60196  
U.S.A.

\* The Radio Products Services Division (RPSD) was formerly known as the Customer Care and Services Division (CCSD) and/or the Accessories and Aftermarket Division (AAD).

## A.4 Telephone Orders

Radio Products Services Division\*  
(United States and Canada)  
7:00 AM to 7:00 PM (Central Standard Time)  
Monday through Friday (Chicago, U.S.A.)  
1-800-422-4210  
1-847-538-8023 (International Orders)

U.S. Federal Government Markets Division (USFGMD)  
1-800-826-1913 Federal Government Parts - Credit Cards Only  
8:30 AM to 5:00 PM (Eastern Standard Time)

---

## **A.5 Fax Orders**

Radio Products Services Division\*  
(United States and Canada)  
1-800-622-6210  
847-576-3023 (International)

USFGMD  
(Federal Government Orders)  
1-800-526-8641 (For Parts and Equipment Purchase Orders)

## **A.6 Parts Identification**

Radio Products Services Division\*  
(United States and Canada)  
1-800-422-4210, menu 3

## **A.7 Product Customer Service**

Customer Response Center  
(Non-technical Issues)  
1-800-247-2346  
FAX:1-800-247-2347

\* The Radio Products Services Division (RPSD) was formerly known as the Customer Care and Services Division (CCSD) and/or the Accessories and Aftermarket Division (AAD).



---

## Appendix B Environmental Information

The ASTRO XTL 5000 700–800 MHz digital mobile radio was designed using Design for Environment (DfE) principles. The electronic portions of the product achieved a 59% percent reduction in the lead content and a 73% reduction in halogen content. Using Motorola-proprietary software (GDA), Motorola determined this product is 98% recoverable and 73% recyclable. An estimate of the material content is provided in the following table:

<b>Material</b>	<b>% by Weight</b>
Aluminum	77.3
Plastic	6.2
PWB	11.8
Steel	2.3

There are no embedded batteries in this product.

Do not dispose of this product in a landfill. Motorola, Inc. encourages reuse or recycling of the material used to manufacture this product. Please contact the Motorola, Inc. Commercial, Government, and Industrial Solutions Sector (CGISS) at 1-888-567-7347 or your local sales representative for rebate programs and for the latest disassembly and recycling strategies.

## Notes

---

# Glossary

This glossary contains an alphabetical listing of terms and their definitions that are applicable to ASTRO portable and mobile subscriber radio products. All terms do not necessarily apply to all radios, and some terms are merely generic in nature.

Term	Definition
<b>A/D</b>	<i>See analog-to-digital conversion.</i>
<b>Abacus IC</b>	A custom integrated circuit providing a digital receiver intermediate frequency (IF) backend.
<b>ADC</b>	<i>See analog-to-digital converter.</i>
<b>ADDAG</b>	<i>See Analog-to-Digital, Digital-to-Analog and Glue.</i>
<b>ALC</b>	<i>See automatic level control.</i>
<b>analog</b>	Refers to a continuously variable signal or a circuit or device designed to handle such signals. <i>See also digital.</i>
<b>Analog-to-Digital, Digital-to-Analog and Glue</b>	An integrated circuit designed to be an interface between the radio's DSP, which is digital, and the analog transmitter and receiver ICs.
<b>analog-to-digital conversion</b>	Conversion of an instantaneous dc voltage level to a corresponding digital value. <i>See also D/A.</i>
<b>analog-to-digital converter</b>	A device that converts analog signals into digital data. <i>See also DAC.</i>
<b>APCO 25</b>	A standard of digital two-way radio communications, developed by the Association of Public-Safety Communications Officials, providing maximum radio spectrum efficiency; competition in system life cycle procurements; effective, efficient and reliable intra-agency and inter-agency communications; and "user friendly" equipment. <i>See also Association of Public-Safety Communications Officials.</i>
<b>Association of Public-Safety Communications Officials</b>	An association dedicated to an industry-wide effort (known as APCO 25 or Project 25) to set the recommended voluntary standards of uniform digital two-way radio technology for public safety organizations. This allows radio interoperability with multiple vendor products which are all APCO 25 compatible. <i>See also APCO 25.</i>
<b>automatic level control</b>	A circuit in the transmit RF path that controls RF power amplifier output, provides leveling over frequency and voltage, and protects against high VSWR.
<b>band</b>	Frequencies allowed for a specific purpose.

---

---

Term	Definition
<b>BBP</b>	<i>See baseband interface port.</i>
<b>baseband interface port</b>	Synchronous serial interface to the transceiver board used to transfer transmit and receive audio data.
<b>BGA</b>	<i>See ball grid array.</i>
<b>ball grid array</b>	A type of IC package characterized by solder balls arranged in a grid that are located on the underside of the package.
<b>CODEC</b>	<i>See coder/decoder.</i>
<b>coder/decoder</b>	A device that encodes or decodes a signal.
<b>CPS</b>	<i>See Customer Programming Software.</i>
<b>Customer Programming Software</b>	Software with a graphical user interface containing the feature set of an ASTRO radio. <i>See also RSS.</i>
<b>D/A</b>	<i>See digital-to-analog conversion.</i>
<b>DAC</b>	<i>See digital-to-analog converter.</i>
<b>Data communication equipment</b>	Definition for device (such as radio) data communications using the RS232 protocol. The correct data communication wiring requires the device's TX pins (output) to connect to the RX pins (input) and the RTS pins (output) to connect to the CTS pins (input). It is incorrect to attach device pins having the same name to to each other.
<b>Data terminal equipment</b>	Data terminal equipment; for example, a computer.
<b>DCE</b>	<i>See Data communication equipment.</i>
<b>default</b>	A pre-defined set of parameters.
<b>digital</b>	Refers to data that is stored or transmitted as a sequence of discrete symbols from a finite set; most commonly this means binary data represented using electronic or electromagnetic signals. <i>See also analog.</i>
<b>digital-to-analog conversion</b>	Conversion of a digital signal to a voltage that is proportional to the input value. <i>See also A/D.</i>
<b>digital-to-analog converter</b>	A device that converts digital data into analog signals. <i>See also ADC.</i>
<b>Digital Private-Line</b>	A type of digital communications that utilizes privacy call, as well as memory channel and busy channel lock out to enhance communication efficiency.

Term	Definition
<b>digital signal processor</b>	A microcontroller specifically designed for performing the mathematics involved in manipulating analog information, such as sound, that has been converted into a digital form. DSP also implies the use of a data compression technique.
<b>digital signal processor code</b>	Object code executed by the Digital Signal Processor in an ASTRO subscriber radio. The DSP is responsible for computation-intensive tasks, such as decoding ASTRO signaling.
<b>DPL</b>	<i>See Digital Private-Line. See also PL.</i>
<b>DSP</b>	<i>See digital signal processor.</i>
<b>DSP code</b>	<i>See digital signal processor code.</i>
<b>DTE</b>	<i>See Data terminal equipment.</i>
<b>DTMF</b>	<i>See dual tone multi-frequency.</i>
<b>dual tone multi-frequency</b>	The system used by touch-tone telephones. DTMF assigns a specific frequency, or tone, to each key so that it can easily be identified by a microprocessor.
<b>EEPOT</b>	Electrically Programmable Digital Potentiometer.
<b>EEPROM</b>	<i>See Electrically Erasable Programmable Read-Only Memory.</i>
<b>Electrically Erasable Programmable Read-Only Memory</b>	A special type of PROM that can be erased by exposing it to an electrical charge. An EEPROM retains its contents even when the power is turned off.
<b>FCC</b>	Federal Communications Commission.
<b>firmware</b>	Code executed by an embedded processor such as the Host or DSP in a subscriber radio. This type of code is typically resident in non-volatile memory and as such is more difficult to change than code executed from RAM.
<b>FGU</b>	<i>See frequency generation unit.</i>
<b>flash</b>	A non-volatile memory device similar to an EEPROM. Flash memory can be erased and reprogrammed in blocks instead of one byte at a time.
<b>FLASHcode</b>	A 13-digit code which uniquely identifies the System Software Package and Software Revenue Options that are enabled in a particular subscriber radio. FLASHcodes are only applicable for radios which are upgradeable through the FLASHport process.
<b>FLASHport</b>	A Motorola term that describes the ability of a radio to change memory. Every FLASHport radio contains a FLASHport EEPROM memory chip that can be software written and rewritten to, again and again.
<b>FMR</b>	<i>See Florida Manual Revision.</i>

---

Term	Definition
<b>Florida Manual Revision</b>	A publication that provides supplemental information for its parent publication before it is revised and reissued.
<b>frequency</b>	Number of times a complete electromagnetic-wave cycle occurs in a fixed unit of time (usually one second).
<b>frequency generation unit</b>	This unit generates ultra-stable, low-phase noise master clock and other derived synchronization clocks that are distributed throughout the communication network.
<b>General-Purpose Input/Output</b>	Pins whose function is programmable.
<b>GPIO</b>	<i>See General-Purpose Input/Output.</i>
<b>host code</b>	Object code executed by the host processor in an ASTRO subscriber radio. The host is responsible for control-oriented tasks such as decoding and responding to user inputs.
<b>IC</b>	<i>See integrated circuit.</i>
<b>IF</b>	Intermediate Frequency.
<b>IMBE</b>	A sub-band, voice-encoding algorithm used in ASTRO digital voice.
<b>inbound signaling word</b>	Data transmitted on the control channel from a subscriber unit to the central control unit.
<b>integrated circuit</b>	An assembly of interconnected components on a small semiconductor chip, usually made of silicon. One chip can contain millions of microscopic components and perform many functions.
<b>ISW</b>	<i>See inbound signaling word.</i>
<b>key-variable loader</b>	A device used to load encryption keys into a radio.
<b>kHz</b>	<i>See kilohertz.</i>
<b>kilohertz</b>	One thousand cycles per second. Used especially as a radio-frequency unit.
<b>KVL</b>	<i>See key-variable loader.</i>
<b>LCD</b>	<i>See liquid-crystal display.</i>
<b>LED</b>	<i>See light emitting diode.</i>
<b>light emitting diode</b>	An electronic device that lights up when electricity is passed through it.
<b>liquid-crystal display</b>	An LCD uses two sheets of polarizing material with a liquid-crystal solution between them. An electric current passed through the liquid causes the crystals to align so that light cannot pass through them.
<b>LO</b>	Local oscillator.

Term	Definition
<b>low-speed handshake</b>	150-baud digital data sent to the radio during trunked operation while receiving audio.
<b>LSH</b>	<i>See low-speed handshake.</i>
<b>Master In Slave Out</b>	SPI data line from a peripheral to the MCU.
<b>Master Out Slave In</b>	SPI data line from the MCU to a peripheral.
<b>MCU</b>	<i>See microcontroller unit.</i>
<b>MDC</b>	Motorola Digital Communications.
<b>MDI</b>	MCU/DSP Interface internal to the Patriot IC.
<b>MHz</b>	<i>See Megahertz.</i>
<b>Megahertz</b>	One million cycles per second. Used especially as a radio-frequency unit.
<b>microcontroller unit</b>	Also written as $\mu\text{C}$ . A microprocessor that contains RAM and ROM components, as well as communications and programming components and peripherals.
<b>MISO</b>	<i>See Master In Slave Out.</i>
<b>MOSI</b>	<i>See Master Out Slave In.</i>
<b>multiplexer</b>	An electronic device that combines several signals for transmission on some shared medium (e.g., a telephone wire).
<b>MUX</b>	<i>See multiplexer.</i>
<b>NiCd</b>	Nickel-cadmium.
<b>NiMH</b>	Nickel-metal-hydride.
<b>OMPAC</b>	<i>See over-molded pad-array carrier.</i>
<b>open architecture</b>	A controller configuration that utilizes a microprocessor with extended ROM, RAM, and EEPROM.
<b>oscillator</b>	An electronic device that produces alternating electric current and commonly employs tuned circuits and amplifying components.
<b>OSW</b>	<i>See outbound signaling word.</i>
<b>OTAR</b>	<i>See over-the-air rekeying.</i>
<b>outbound signaling word</b>	Data transmitted on the control channel from the central controller to the subscriber unit.
<b>over-molded pad-array carrier</b>	A Motorola custom IC package, distinguished by the presence of solder balls on the bottom pads.

---

Term	Definition
<b>over-the-air rekeying</b>	Allows the dispatcher to remotely reprogram the encryption keys in the radio.
<b>PA</b>	Power amplifier.
<b>paging</b>	One-way communication that alerts the receiver to retrieve a message.
<b>Patriot IC</b>	A dual-core processor that contains an MCU and a DSP in one IC package.
<b>PC Board</b>	Printed Circuit Board. Also referred to as a PCB.
<b>phase-locked loop</b>	A circuit in which an oscillator is kept in phase with a reference, usually after passing through a frequency divider.
<b>PL</b>	<i>See private-line tone squelch.</i>
<b>PLL</b>	<i>See phase-locked loop.</i>
<b>private-line tone squelch</b>	A continuous sub-audible tone that is transmitted along with the carrier. <i>See also DPL.</i>
<b>Programmable Read-Only Memory</b>	A memory chip on which data can be written only once. Once data has been written onto a PROM, it remains there forever.
<b>programming cable</b>	A cable that allows the CPS to communicate directly with the radio using RS232.
<b>Project 25</b>	<i>See APCO 25.</i>
<b>PROM</b>	<i>See Programmable Read-Only Memory.</i>
<b>PTT</b>	<i>See Push-to-Talk.</i>
<b>Push-to-Talk</b>	The switch or button usually located on the left side of the radio which, when pressed, causes the radio to transmit. When the PTT is released, the unit returns to receive operation.
<b>radio frequency</b>	The portion of the electromagnetic spectrum between audio sound and infrared light (approximately 10 kHz to 10 GHz).
<b>radio frequency power amplifier</b>	Amplifier having one or more active devices to amplify radio signals.
<b>Radio Interface Box</b>	The radio communicates directly to the computer via a single programming cable. Not used with XTL 5000.
<b>Radio Service Software</b>	Not used with XTL 5000. <i>See Customer Programming Software.</i>
<b>RAM</b>	<i>See random access memory.</i>
<b>random access memory</b>	A type of computer memory that can be accessed randomly; that is, any byte of memory can be accessed without touching the preceding bytes.



Term	Definition
<b>read-only memory</b>	A type of computer memory on which data has been prerecorded. Once data has been written onto a ROM chip, it cannot be removed and can only be read.
<b>real-time clock</b>	A module that keeps track of elapsed time even when a computer is turned off.
<b>receiver</b>	Electronic device that amplifies RF signals. A receiver separates the audio signal from the RF carrier, amplifies it, and converts it back to the original sound waves.
<b>registers</b>	Short-term data-storage circuits within the microcontroller unit or programmable logic IC.
<b>repeater</b>	Remote transmit/receive facility that re-transmits received signals in order to improve communications range and coverage (conventional operation).
<b>repeater/talkaround</b>	A conventional radio feature that permits communication through a receive/transmit facility, which re-transmits received signals in order to improve communication range and coverage.
<b>RESET</b>	Reset line: an input to the microcontroller that restarts execution.
<b>RF</b>	<i>See radio frequency.</i>
<b>RF PA</b>	<i>See radio frequency power amplifier.</i>
<b>RIB</b>	<i>See Radio Interface Box.</i>
<b>ROM</b>	<i>See read-only memory.</i>
<b>RPCIC</b>	Regulator/power control IC.
<b>RPT/TA</b>	<i>See repeater/talkaround.</i>
<b>RS232</b>	A common interface standard for data communications equipment.
<b>RSS</b>	<i>See Radio Service Software.</i>
<b>RTC</b>	<i>See real-time clock.</i>
<b>RX</b>	Receive.
<b>RX DATA</b>	Recovered digital data line.
<b>SAP</b>	<i>See Serial Audio CODEC Port.</i>
<b>Serial Audio CODEC Port</b>	SSI to and from the GCAP II IC CODEC used to transfer transmit and receive audio data.
<b>Serial Communication Interface Input Line</b>	A full-duplex (receiver/transmitter) asynchronous serial interface.

---

Term	Definition
<b>Serial Input/Output IC</b>	An integrated circuit that provides SB9600 serial and power-control functions.
<b>SCI IN</b>	<i>See Serial Communication Interface Input Line.</i>
<b>Serial Peripheral Interface</b>	How the microcontroller communicates to modules and ICs through the CLOCK and DATA lines.
<b>signal</b>	An electrically transmitted electromagnetic wave.
<b>Signal Qualifier mode</b>	An operating mode in which the radio is muted, but still continues to analyze receive data to determine RX signal type.
<b>SIO IC</b>	<i>See Serial Input/Output IC.</i>
<b>softpot</b>	<i>See software potentiometer.</i>
<b>software</b>	Computer programs, procedures, rules, documentation, and data pertaining to the operation of a system.
<b>software potentiometer</b>	A computer-adjustable electronic attenuator.
<b>spectrum</b>	Frequency range within which radiation has specific characteristics.
<b>SPI</b>	<i>See Serial Peripheral Interface.</i>
<b>squelch</b>	Muting of audio circuits when received signal levels fall below a pre-determined value. With carrier squelch, all channel activity that exceeds the radio's preset squelch level can be heard.
<b>SRAM</b>	<i>See static RAM.</i>
<b>SRIB</b>	Smart Radio Interface Box. <i>See RIB.</i>
<b>SSI</b>	<i>See Synchronous Serial Interface.</i>
<b>Standby mode</b>	An operating mode in which the radio is muted but still continues to monitor data.
<b>static RAM</b>	A type of memory used for volatile, program/data memory that does not need to be refreshed.
<b>Synchronous Serial Interface</b>	DSP interface to peripherals that consists of a clock signal line, a frame synchronization signal line, and a data line.
<b>system central controllers</b>	Main control unit of the trunked dispatch system; handles ISW and OSW messages to and from subscriber units ( <i>See ISW and OSW</i> ).
<b>system select</b>	The act of selecting the desired operating system with the system-select switch (also, the name given to this switch).
<b>thin small-outline package</b>	A type of dynamic random-access memory (DRAM) package that is commonly used in memory applications.

Term	Definition
<b>time-out timer</b>	A timer that limits the length of a transmission.
<b>TOT</b>	<i>See time-out timer.</i>
<b>transceiver</b>	Transmitter-receiver. A device that both transmits and receives analog or digital signals. Also abbreviated as XCVR.
<b>transmitter</b>	Electronic equipment that generates and amplifies an RF carrier signal, modulates the signal, and then radiates it into space.
<b>TSOP</b>	<i>See thin small-outline package.</i>
<b>TX</b>	Transmit.
<b>UART</b>	<i>See also Universal Asynchronous Receiver Transmitter.</i>
<b>UHF</b>	Ultra-High Frequency.
<b>Universal Asynchronous Receiver Transmitter</b>	A microchip with programming that controls a computer's interface to its attached serial devices.
<b>Universal Serial Bus</b>	An external bus standard that supports data transfer rates of 12 Mbps.
<b>USB</b>	<i>See Universal Serial Bus.</i>
<b>VCO</b>	<i>See voltage-controlled oscillator.</i>
<b>vector sum excited linear predictive coding</b>	Not used with XTL 5000. Replaced with the APCO 25 standard. <i>See APCO 25.</i>
<b>VHF</b>	Very-High Frequency.
<b>VIP</b>	Vehicle Interface Port.
<b>VOCON</b>	<i>See vocoder/controller.</i>
<b>vocoder</b>	An electronic device for synthesizing speech by implementing a compression algorithm particular to voice. <i>See also voice encoder.</i>
<b>vocoder/controller</b>	A PC board that contains an ASTRO radio's microcontroller, DSP, memory, audio and power functions, and interface support circuitry.
<b>voice encoder</b>	The DSP-based system for digitally processing analog signals, and includes the capabilities of performing voice compression algorithms or voice encoding. <i>See also vocoder.</i>
<b>voltage-controlled oscillator</b>	An oscillator in which the frequency of oscillation can be varied by changing a control voltage.
<b>VSELP</b>	<i>See vector sum excited linear predictive coding.</i>

## Notes

# Index

## Numerics

700-800 MHz radio specifications .....xxi

## A

accessory connector, J2 .....9-1  
advanced secure operation .....7-3  
alignment procedures  
  power detector calibration .....6-8  
  reference oscillator .....6-6  
  tuner introduction .....6-1  
  Tx current limit .....6-10  
  Tx deviation balance (compensation) .....6-12  
  Tx deviation limit .....6-14  
  Tx power characterization .....6-9  
analog mode of operation .....3-6  
annunciator, secure status .....7-1  
ASTRO mode of operation .....3-6  
audio PA Out bias .....9-5

## B

backlight LEDs, control head .....3-7  
bit error rate (BER) test .....6-16  
block diagram, functional .....10-2

## C

cabling  
  connector naming schemes .....10-7  
  control head connector pin arrangement .....10-6  
  control head diagram .....10-5  
calibration, mic sensitivity .....6-18  
chassis pad replacement .....8-30  
codes  
  operational error .....9-7  
  power-up error .....9-5  
connector  
  control head pin arrangement .....10-6  
  locations .....10-4  
  naming schemes .....10-7  
connectors, radio  
  locations .....10-4  
  pin arrangements .....10-3  
control head  
  backlight LEDs .....3-7  
  board replacement .....8-2  
  cabling .....10-5  
  connector pin arrangement .....10-6  
  controls .....1-5  
  controls and indicators .....3-7  
  descriptions .....1-2  
  ignition sense circuits .....3-8  
  status LEDs .....3-7

  theory of operation .....3-6  
controller section, radio .....3-2  
controls, control head .....1-5, 3-7  
copyrights  
  computer software .....ii  
  document .....ii

## D

dash-mount vehicle interface port .....3-8  
daughtercard module .....3-2  
descriptions  
  control heads .....1-2  
  radio .....1-1  
disassembly/reassembly  
  introduction .....8-1  
  radio  
    disassembly .....8-8  
    reassembly .....8-19  
  required tools and supplies .....8-1  
W3 control head board  
  disassembly .....8-2  
  reassembly .....8-3  
W4, W5, W7 control head board  
  disassembly .....8-4  
  reassembly .....8-5  
W4, W5, W7 remote back housing interface board  
  disassembly .....8-7  
  reassembly .....8-7  
W9 control head board  
  disassembly .....8-6  
  reassembly .....8-6  
disclaimer information .....ii  
displays, front-panel access test-mode .....5-2

## E

encryption  
  advanced secure operation .....7-3  
  conventional multikey .....7-3  
  erasing  
    a single key .....7-6  
    all keys .....7-6  
    keys .....7-3  
  key loading .....7-2  
  multikey operation .....7-3  
  over-the-air rekeying .....7-7  
  secure  
    dispatch operation .....7-1  
    emergency operation .....7-2  
    interface boards .....7-1  
    status annunciator .....7-1  
    trunked multikey .....7-3  
    universal crypto module kits .....7-1  
environmental information .....B-1  
erasing  
  all encryption keys .....7-6  
  encryption keys .....7-3  
  single encryption key .....7-6  
error message, W3 control-head .....4-4

- 
- exploded view
    - interconnect board ..... 11-7
    - motorcycle
      - fuel-tank console installation ..... 11-10
      - handlebar installation ..... 11-9
      - interconnect board ..... 11-7
      - microphone ..... 11-11
      - radio enclosure ..... 11-12
      - remote-mount control head ..... 11-8
      - speaker ..... 11-11
      - universal mounting plate ..... 11-13
    - W3 control head ..... 11-2
    - W5 control head ..... 11-4
    - W7 control head ..... 11-4
    - W9 control head ..... 11-5
    - XTL 5000 (3.5-35 W) ..... 11-6
  - F**
  - fastener torque values ..... 8-32
  - field programming
    - dash-mounted radios ..... 4-3
    - equipment ..... 4-3
    - remote-mounted radios ..... 4-4
    - W3 control-head error message ..... 4-4
  - FLASH IC ..... 3-3
  - FLASHport technology ..... 1-2
  - frequencies, test ..... 5-3
  - frequency generation unit (FGU) theory of operation . 3-11
  - front and rear connectors ..... 3-4
  - front-panel access test-mode displays ..... 5-2
  - functional block diagram, XTL 5000 ..... 10-2
  - H**
  - handling precautions ..... 2-2
  - heatsinkong precautions, RF PA ..... 2-2
  - I**
  - I/O disclaimer ..... 9-3
  - ignition sense circuits, control head ..... 3-8
  - indicators, control head ..... 3-7
  - interconnect board
    - exploded view ..... 11-7
    - replacement ..... 8-7
  - J**
  - J2 accessory connector ..... 9-1
  - K**
  - key, erasing encryption ..... 7-3
  - key-variable loader (KVL) ..... 7-2
  - kits, universal crypto module (UCM) ..... 7-1
  - L**
  - loading encryption keys ..... 7-2
  - M**
  - maintenance
    - cleaning
      - external plastic surfaces ..... 2-1
      - general ..... 2-1
      - internal circuit boards and components ..... 2-2
    - general radio care ..... 2-2
    - handling instructions ..... 2-2
    - inspection ..... 2-1
    - preventive ..... 2-1
  - manual
    - notations ..... 1-1
    - revisions ..... ii
  - mic sensitivity calibration ..... 6-18
  - microphone bias ..... 9-4
  - microprocessor ..... 3-3
  - mobile model chart ..... xix
  - mode
    - analog operation ..... 3-6
    - ASTRO operation ..... 3-6
    - control-head test ..... 5-4
    - performance checks test ..... 5-1
    - RF test ..... 5-3
  - model chart
    - mobile ..... xix
    - motorcycle ..... xviii
  - model numbering scheme ..... xvii
  - motorcycle
    - fuel-tank console installation exploded view ..... 11-10
    - handlebar installation exploded view ..... 11-9
    - interconnect board exploded view ..... 11-7
    - interconnect board parts list ..... 11-7
    - microphone exploded view ..... 11-11
    - model chart ..... xviii
    - radio enclosure exploded view ..... 11-12
    - remote-mount control head exploded view ..... 11-8
    - remote-mount control head with speaker and microphone ..... 11-8
    - speaker exploded view ..... 11-11
    - universal mounting plate exploded view ..... 11-13
  - multikey operation
    - conventional ..... 7-3
    - introduction ..... 7-3
    - trunked ..... 7-3
  - N**
  - notations
    - manual ..... 1-1
    - warning, caution, and danger ..... 1-1
  - O**
  - operation
    - advanced secure ..... 7-3
    - analog mode ..... 3-6
    - ASTRO mode ..... 3-6
-

- control head ..... 3-6
  - conventional multikey ..... 7-3
  - multikey ..... 7-3
  - trunked multikey ..... 7-3
  - operational error codes ..... 9-7
  - ordering replacement parts ..... A-1
  - over-the-air rekeying ..... 7-7
  - overview, basic theory ..... 3-1
- P**
- pad replacement, chassis ..... 8-30
  - parts list
    - large pushbuttons ..... 11-13
    - low- and mid-power interconnect board ..... 11-7
    - motorcycle
      - interconnect board ..... 11-7
      - microphone ..... 11-11
      - remote-mount control head with speaker and microphone ..... 11-8
      - weather-resistant radio enclosure ..... 11-12
      - weather-resistant speaker ..... 11-11
    - radio (3.5-35 W) ..... 11-6
    - small pushbuttons ..... 11-13
    - W3 control head ..... 11-2
    - W4 control head ..... 11-3
    - W5 control head ..... 11-4
    - W7 control head ..... 11-4
    - W9 control head ..... 11-5
  - parts, ordering replacement ..... A-1
  - performance checks
    - overview ..... 5-1
    - receiver ..... 5-5
    - signaling types ..... 5-4
    - test
      - frequencies ..... 5-3
      - mode ..... 5-1
      - setup ..... 5-1
    - transmitter ..... 5-6
  - power detector calibration alignment ..... 6-8
  - power-up error codes ..... 9-5
  - preventive maintenance, periodic ..... 2-1
  - product safety information ..... ii
  - programming
    - dash-mounted radios ..... 4-3
    - equipment, field ..... 4-3
    - remote-mounted radios ..... 4-4
    - W3 control-head error message ..... 4-4
  - pushbuttons
    - large ..... 11-13
    - small ..... 11-13
- R**
- radio
    - connectors
      - locations ..... 10-4
      - pin arrangements ..... 10-3
    - descriptions ..... 1-1
    - information screen ..... 6-3
    - programming
      - dash-mounted ..... 4-3
      - remote-mounted ..... 4-4
    - specifications, 700-800 MHz ..... xxi
    - upgrading with FLASHport ..... 1-2
  - radio care and handling instructions, general ..... 2-2
  - receiver
    - Abacus III back-end ..... 3-10
    - front-end ..... 3-10
    - IF circuitry ..... 3-10
    - mixer ..... 3-10
    - performance checks ..... 5-5
    - theory of operation ..... 3-10
    - troubleshooting ..... 9-8
  - recycling information, radio ..... B-1
  - reference oscillator alignment ..... 6-6
  - remote control-head board replacement ..... 8-7
  - remote-mount vehicle interface port ..... 3-8
  - replacement parts, ordering ..... A-1
  - replacement, chassis pad ..... 8-30
  - replacing
    - control-head boards ..... 8-2
    - interconnect board ..... 8-7
    - remote control-head board ..... 8-7
  - RF exposure compliance information ..... ii
  - RF PA
    - circuit protection ..... 3-9
    - DC interconnect ..... 3-9
    - gain stages ..... 3-9
    - heatsinking precautions ..... 2-2
    - power control ..... 3-9
  - RF test mode ..... 5-3
- S**
- screen, tuner
    - main menu ..... 6-2
    - radio information ..... 6-3
    - transmit current limit alignment ..... 6-11
  - secure
    - dispatch operation ..... 7-1
    - emergency operation ..... 7-2
    - interface boards ..... 7-1
    - status annunciator ..... 7-1
  - secure operation, key-variable loader ..... 7-2
  - service aids, recommended ..... 4-2
  - signaling types ..... 5-4
  - specifications, 700-800 MHz radio ..... xxi
  - SRAM IC ..... 3-3
  - status LEDs, control head ..... 3-7
- T**
- test
    - bit error rate (BER) ..... 6-16
    - equipment, recommended ..... 4-1
    - frequencies ..... 5-3
    - setup, performance checks ..... 5-1
    - transmitter test pattern ..... 6-17
  - test mode
    - control-head ..... 5-4
    - displays ..... 5-2
    - performance checks ..... 5-1
    - RF ..... 5-3
  - theory of operation
    - analog mode ..... 3-6

ASTRO mode .....	3-6	transmit current limit alignment .....	6-11
control head		Tx current limit alignment .....	6-10
backlight LEDs .....	3-7	Tx deviation balance (compensation) alignment ....	6-12
controls and indicators .....	3-7	Tx deviation limit alignment .....	6-14
ignition sense circuits .....	3-8	Tx power characterization alignment .....	6-9
status LEDs .....	3-7	types of signaling .....	5-4
vacuum flourescent display driver .....	3-7		
vacuum flourescent voltage source (W9) .....	3-7	<b>U</b>	
vehicle interface port		universal crypto module (UCM) kits .....	7-1
dash-mount .....	3-8		
remote-mount .....	3-8	<b>V</b>	
W4, W5, W7 .....	3-6	vacuum flourescent	
W9 .....	3-7	display driver .....	3-7
controller section .....	3-2	voltage source (W9) .....	3-7
daughtercard module .....	3-2	vehicle interface port	
FLASH IC .....	3-3	dash-mount .....	3-8
microprocessor .....	3-3	remote-mount .....	3-8
SRAM IC .....	3-3	view, exploded	
frequency generation unit (FGU) .....	3-11	interconnect board .....	11-7
output network section components .....	3-9	motorcycle	
overview .....	3-1	fuel-tank console installation .....	11-10
radio-frequency power amplifier		handlebar installation .....	11-9
circuit protection .....	3-9	interconnect board .....	11-7
components .....	3-9	microphone .....	11-11
DC interconnect .....	3-9	radio enclosure .....	11-12
gain stages .....	3-9	remote-mount control head .....	11-8
power control .....	3-9	speaker .....	11-11
receiver		universal mounting plate .....	11-13
Abacus III back-end .....	3-10	W3 control head .....	11-2
component blocks .....	3-10	W5 control head .....	11-4
front-end .....	3-10	W7 control head .....	11-4
IF circuitry .....	3-10	W9 control head .....	11-5
mixer .....	3-10	XTL 5000 (3.5-35 W) .....	11-6
surrounding controller region		<b>W</b>	
components .....	3-3	W3 control head exploded view .....	11-2
emergency .....	3-4	W5 control head exploded view .....	11-4
front and rear connectors .....	3-4	W7 control head exploded view .....	11-4
voltage regulation .....	3-4	W9 control head expoded view .....	11-5
tools required, disassembly/reassembly .....	8-1	warning, caution, and danger notations .....	1-1
tools, recommended .....	4-2		
torque values, fastener .....	8-32		
trademark information .....	ii		
transmit current limit alignment screen .....	6-11		
transmitter			
performance checks .....	5-6		
troubleshooting .....	9-7		
transmitter test pattern test .....	6-17		
troubleshooting			
audio PA Out bias .....	9-5		
I/O disclaimer .....	9-3		
introduction .....	9-1		
J2 accessory connector .....	9-1		
microphone bias .....	9-4		
operational error codes .....	9-7		
power-up error codes .....	9-5		
receiver .....	9-8		
replacing boards .....	9-5		
transmitter .....	9-7		
trunked multikey operation .....	7-3		
tuner			
main menu screen .....	6-2		
radio alignment introduction .....	6-1		
screen			
main menu .....	6-2		
radio information .....	6-3		







Motorola, Inc.  
8000 West Sunrise Boulevard  
Ft. Lauderdale, FL 33322

MOTOROLA, the Stylized M Logo, and ASTRO are registered in the U.S. Patent and Trademark Office. All other product or service names are the property of their respective owners.  
© Motorola, Inc. 2003.  
All rights reserved. Printed in U.S.A.



68P81096C73-O