

ASTRO Digital SABER
Portable Radios
Basic Service Manual

68P81076C05

FOREWORD

The information contained in this manual relates to all ASTRO Digital SABER radios, unless otherwise specified.

SAFETY INFORMATION

The Federal Communications Commission (FCC), with its action in General Docket 79-144, March 13, 1985, has adopted a safety standard for human exposure to radio frequency (RF) electromagnetic energy emitted by FCC-regulated equipment. Motorola subscribes to the same safety standard for the use of its products. Proper operation of this radio will result in user exposure substantially below FCC recommended limits.

- **DO NOT** hold the radio with the antenna very close to, or touching, exposed parts of the body, especially the face, ears, or eyes, while transmitting. Hold the radio in a vertical position with the microphone two to three inches away from the lips.
- **DO NOT** hold the transmit switch (PTT) on when not actually desiring to transmit.
- **DO NOT** allow children to play with any radio equipment containing a transmitter.
- **DO NOT** operate this equipment near electrical blasting caps or in an explosive atmosphere. Under certain conditions, radios can interfere with blasting operations. When you are in the vicinity of construction work, look for, and observe, signs cautioning against radio transmissions. If radio transmission is prohibited, you must not transmit until out of the area. Furthermore, *you must turn off* your radio to prevent any accidental transmission.
- **DO NOT** replace or charge batteries in a hazardous atmosphere. Contact sparking may occur while installing or removing batteries and cause an explosion.
- **TURN THE RADIO OFF** when removing or installing a battery.

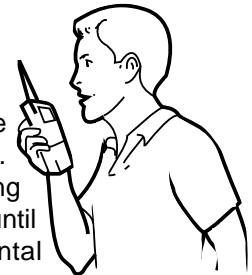

MAEPF-17813-A

Anyone intending to use a radio in a hazardous area is advised to become familiar with the subject of intrinsic safety and with Section 70 of the National Fire Code, which is commonly referred to as Article 500 of the National Electric Code. Use of anything but factory supplied components may affect the approval and safety of the radio. Likewise, it is advised that servicing should be performed only by qualified personnel who adhere to the following Factory Mutual (FM) required warning:

WARNING

Modification of FM approved intrinsically safe radios will negate Factory Mutual Research Corporation (FMRC) approval.

MANUAL REVISIONS

Changes which occur after this manual is printed are described in "FMRs." These FMRs provide complete information on changes including pertinent parts listing data.

COMPUTER SOFTWARE COPYRIGHTS

The Motorola products described in this manual may include copyrighted Motorola computer programs stored in semiconductor memories or other media. Laws in the United States and other countries preserve for Motorola certain exclusive rights for copyrighted computer programs, including the exclusive right to copy or reproduce in any form the copyrighted computer program. Accordingly, any copyrighted Motorola computer programs contained in the Motorola products described in this manual may not be copied or reproduced in any manner without the express written permission of Motorola. Furthermore, the purchase of Motorola products shall not be deemed to grant either directly or by implication, estoppel, or otherwise, any license under the copyrights, patents or patent applications of Motorola, except for the normal non-exclusive royalty free license to use that arises by operation of law in the sale of a product.

CONTENTS

TITLE	PAGE
FOREWORD.....	<i>inside front cover</i>
LIST OF TABLES	<i>ii</i>
LIST OF ILLUSTRATIONS.....	<i>ii</i>
RELATED PUBLICATIONS AVAILABLE SEPARATELY.....	<i>ii</i>
PORTABLE RADIO MODEL NUMBERING SYSTEM.....	<i>iii</i>
SPECIFICATIONS FOR VHF RADIOS.....	<i>iv</i>
SPECIFICATIONS FOR UHF RADIOS.....	<i>v</i>
SPECIFICATIONS FOR 800MHz RADIOS.....	<i>vi</i>
SECTION I. INTRODUCTION	
A. General	1
B. Radio Description.....	1
C.  FLASHport	1
SECTION II. BASIC MAINTENANCE	
A. Introduction to This Section	3
B. Preventive Maintenance	3
C. Handling Precautions.....	3
SECTION III. RECOMMENDED TEST EQUIPMENT, SERVICE AIDS, AND TOOLS	
A. Recommended Test Equipment	5
B. Service Aids and Recommended Tools.....	6
C. Field Programming Equipment	6
SECTION IV. PERFORMANCE CHECKS	
A. Introduction to This Section	7
B. Setup.....	7
C. Test Mode.....	7
SECTION V. RADIO ALIGNMENT PROCEDURE	
A. Introduction to This Section	11
B. General	11
C. Reference Oscillator Alignment	13
D. Transmit Power Alignment.....	14
E. Transmit Deviation Balance (Compensation) Alignment	15
F. Transmit Deviation Limit Alignment	16
G. Front-End Filter Alignment (VHF/UHF Only).....	17
SECTION VI. DISASSEMBLY/REASSEMBLY PROCEDURES	
A. Disassembly.....	19
B. Servicing Major Subassemblies.....	21
C. Reassembly	22

, Motorola, ASTRO, SABER, FLASHport, SMARTNET, Stat-Alert, SABER SI, CoveragePLUS, Private-Line, and Digital Private Line are trademarks of Motorola, Inc.

CONTENTS (cont.)

TITLE	PAGE
SECTION VII. BASIC THEORY OF OPERATION	
A. Introduction to This Section	23
B. General Overview	23
C. Analog Mode of Operation	23
D. ASTRO Mode of Operation	23
E. RF Board Basic Theory of Operation	23
F. Controller Board Basic Theory of Operation	24
SECTION VIII. BOARD-LEVEL TROUBLESHOOTING	
A. Introduction to This Section	25
B. Replacement Board Procedures	25
C. Power-Up Error Codes	25
D. Operational Error Codes	26
REPLACEMENT PARTS ORDERING	<i>inside back cover</i>

LIST OF TABLES

TABLE	TITLE	PAGE
1	ASTRO Digital SABER Basic Features	1
2	Recommended Test Equipment	5
3	Service Aids for Board-Level Troubleshooting	6
4	Recommended Tools for Board-Level Troubleshooting	6
5	Initial Equipment Control Settings	7
6	Test Environments	7
7	Test Frequencies	8
8	Receiver Performance Checks	9
9	Transmitter Performance Checks	10
10	Reference Oscillator Alignment	13
11	Transmit Power Setting	14
12	Transmit Deviation Limit	16
13	Torque Specifications	22
14	Local Oscillator and First IF Frequencies	24
15	Power-Up Error Code Displays	25
16	Operational Error Code Displays	26
17	Receiver Troubleshooting Chart	26
18	Transmitter Troubleshooting Chart	27

LIST OF ILLUSTRATIONS

FIGURE	TITLE	PAGE
1	Radio Alignment Test Setup	11
2	RSS Service Menu Layout	12
3	Softpot Concept	12
4	Reference Oscillator Alignment Screen	13
5	Transmit Power Alignment Screen	14
6	Transmit Deviation Balance (Compensation) Alignment Screen	15
7	Transmit Deviation Limit Alignment Screen	16
8	Front-End Filter Alignment Screen	17
9	Functional Block Diagram	29
10	Connector Location Details	30
11	Control Top/PTT Flex and Connector Information	31
12	Display Flex and Connector Information	31
13	Speaker/Microphone Flex and Connector Information	32
14	Universal Flex and Connector Information	32
15	Controller Board/RF Board Connector Information	33
16	Controller Board/Encryption Board Connector Information	33
17	Exploded View Diagram and Parts List	34

RELATED PUBLICATIONS AVAILABLE SEPARATELY

TYPE OF MANUAL	MANUAL NUMBER
ASTRO Digital SABER User's Guide	68P81072C80
ASTRO Digital SABER Portable Radios Detailed Service Manual	68P81076C10

PORTABLE RADIO MODEL NUMBERING SYSTEM

Typical Model Number: H 0 4 U C F 9 P W 7 A N S P 0 1
 Position: 1 2 3 4 5 6 7 8 9 10 11 12 13 14 15 16

Position 1 - Type of Unit

H=Hand-Held Portable

Positions 2 & 3 - Model Series

04=ASTRO

Position 4 - Frequency Band

A=Less than 29.7MHz	P=336 to 410MHz
B=29.7 to 35.99MHz	Q=403 to 437MHz
C=36 to 41.99MHz	R=438 to 482MHz
D=42 to 50MHz	S=470 to 520MHz
F=66 to 80MHz	T=Product Specific
G=74 to 90MHz	U=806 to 870MHz
H=Product Specific	V=825 to 870MHz
J=136 to 162MHz	W=896 to 941MHz
K=146 to 178MHz	Y=1.0 to 1.6GHz
L=174 to 210MHz	Z=1.5 to 2.0GHz
M=190 to 235MHz	

* Values given represent range only; they are not absolute.

Position 5 - Power Level

A=0 to 0.7 Watts
 B=0.7 to 0.9 Watts
 C=1.0 to 3.9 Watts
 D=4.0 to 5.0 Watts
 E=5.1 to 6.0 Watts
 F=6.1 to 10 Watts

Position 6 - Physical Packages

A=RF Modem Operation
 B=Receiver Only
 C=Standard Control; No Display
 D=Standard Control; With Display
 E=Limited Keypad; No Display
 F=Limited Keypad; With Display
 G=Full Keypad; No Display
 H=Full Keypad; With Display
 J=Limited Controls; No Display
 K=Limited Controls; Basic Display
 L=Limited Controls; Limited Display
 M=Rotary Controls; Standard Display
 N=Enhanced Controls; Enhanced Display
 P=Low Profile; No Display
 Q=Low Profile; Basic Display
 R=Low Profile; Basic Display, Full Keypad

Position 7 - Channel Spacing

1=5kHz	5=15kHz
2=6.25kHz	6=20/25kHz
3=10kHz	7=30kHz
4=12.5kHz	9=Variable/Programmable

Positions 13 - 16
 "SP" Model Suffix

Position 12 - Unique Model Variations

C=Cenelec
 N=Standard Package

Position 11 - Version

Version Letter (Alpha)-Major Change

Position 10 - Feature Level

1=Basic	6=Standard Plus
2=Limited Package	7=Expanded Package
3=Limited Plus	8=Expanded Plus
4=Intermediate	9=Full Feature/ Programmable
5=Standard Package	

Position 9 - Primary System Type

A=Conventional
 B=Privacy Plus®
 C=Clear SMARTNET™
 D=Advanced Conventional Stat-Alert™
 E=Enhanced Privacy Plus®
 F=Nauganet 888 Series
 G=Japan Specialized Mobile Radio (JSMR)
 H=Multi-Channel Access (MCA)
 J=CoveragePLUS™
 K=MPT1327*-Public
 L=MPT1327*-Private
 M=Radiocom
 N=Tone Signalling
 P=Binary Signalling
 Q=Phonenet®
 W=Programmable
 X=Secure Conventional
 Y=Secure SMARTNET™

* MPT=Ministry of Posts and Telecommunications

Position 8 - Primary Operation

A=Conventional/Simplex
 B=Conventional/Duplex
 C=Trunked Twin Type
 D=Dual Mode Trunked
 E=Dual Mode Trunked/Duplex
 F=Trunked Type I
 G=Trunked Type II
 H=FDMA* Digital Dual Mode
 J=TDMA** Digital Dual Mode
 K=Single Sideband
 L=Global Positioning Satellite Capable
 M=Amplitude Companded Sideband (ACSB)
 P=Programmable
 * FDMA=Frequency Division Multiple Access
 **TDMA=Time Division Multiple Access

SPECIFICATIONS FOR VHF RADIOS

All specifications are per Electronic Industries Association (EIA) 316B unless otherwise noted.

GENERAL	RECEIVER	TRANSMITTER
<p>FCC Designation: AZ489FT3770</p> <p>Temperature Range:</p> <p>Operating: -30°C to +60°C</p> <p>Storage: -40°C to +85°C</p> <p>Power Supply: Nickel-Cadmium Battery (NiCd) or Nickel-Metal-Hydride Battery (NiMH)</p> <p>Battery Voltage:</p> <p>Nominal: 7.5 Volts</p> <p>Range: 6 to 9 Volts</p> <p>Recommended Battery:</p> <p>Medium Capacity NiCd: NTN4593**</p> <p>or Ultra-High Capacity NiCd: NTN4595**</p> <p>or Medium Capacity NiMH: NTN7014</p> <p>or High Capacity NiMH: NTN7251</p> <p><i>Optional FM (Factory Mutual) Battery :</i></p> <p>High Capacity FM: NTN4538**/**</p> <p>or Ultra-High Capacity FM: NTN4596**/**</p> <p>* FM Intrinsically Safe: Class I, II, III, Division 1, Groups D, F, and G</p> <p>** FM Nonincendive: Class I, Division 2, Groups A, B, C, and D</p> <p>Dimensions (H x W x D)</p> <p>Note: 2.64" = width at PTT; 2.94" = width at top</p> <p>Less Battery:</p> <p style="padding-left: 40px;">5.20" x 2.64"/2.94" x 1.23"</p> <p style="padding-left: 40px;">(131.32mm x 67.05/74.67mm x 31.24mm)</p> <p>With Medium Capacity NiCd Battery:</p> <p style="padding-left: 40px;">8.34" x 2.94" x 1.28"</p> <p style="padding-left: 40px;">(211.82mm x 74.67mm x 31.24mm)</p> <p>With Ultra-High Capacity NiCd Battery:</p> <p style="padding-left: 40px;">9.10" x 2.94" x 1.23"</p> <p style="padding-left: 40px;">(231.12mm x 74.67mm x 31.24mm)</p> <p>With High Capacity NiMH Battery:</p> <p style="padding-left: 40px;">8.34" x 2.94" x 1.23"</p> <p style="padding-left: 40px;">(211.82mm x 74.67mm x 31.24mm)</p> <p>Weight: (w/Helical Antenna)</p> <p>Less Battery: 12.8oz. (366gm)</p> <p>With Medium Cap. NiCd : 26.81oz. (759gm)</p> <p>With Ultra-High Cap. NiCd: 29.95oz. (849gm)</p> <p>With High Cap. NiMH: 26.3oz. (746gm)</p>	<p>Frequency Range: 136–178MHz</p> <p>Bandwidth: 42MHz</p> <p>Quieting Sensitivity (20dBQ): 0.5µV Max.</p> <p>Usable Sensitivity (12dB SINAD): 0.35µV Max.</p> <p>Intermodulation: -70dB</p> <p>Selectivity (30kHz Adjacent Channel): -70dB</p> <p>Spurious Rejection: -70dB</p> <p>Frequency Stability (-30 to +60°C; 25°C reference): ± .00025%</p> <p>Rated Audio: 500mW</p> <p>Distortion (At Rated Audio): 3% Typical</p> <p>Channel Spacing: 30kHz</p>	<p>RF Power:</p> <p style="padding-left: 20px;">136-174MHz 1Watt/5 Watts</p> <p style="padding-left: 20px;">174-178MHz 1Watt/4 Watts</p> <p>Frequency Range: 136–178MHz†</p> <p>Frequency Stability (-30 to +60°C; 25°C ref.): ± .00025%</p> <p>Emission (Conducted and Radiated): -66dBw</p> <p>FM Hum and Noise (Companion Receiver): -45dB Typical</p> <p>Distortion: 3% Typical</p> <p>Modulation Limiting: ±5kHz</p> <p>Emissions Designators:</p> <p style="padding-left: 20px;">20K0F1E, 16K0F3E, 15K0F2D, 15K0F1D, and 8K10F1E</p>

Specifications subject to change without notice.

SPECIFICATIONS FOR UHF RADIOS

All specifications are per Electronic Industries Association (EIA) 316B unless otherwise noted.

GENERAL	RECEIVER	TRANSMITTER
<p>FCC Designation: AZ489FT4783</p> <p>Temperature Range: Operating: -30°C to +60°C Storage: -40°C to +85°C</p> <p>Power Supply: Nickel-Cadmium Battery (NiCd) or Nickel-Metal-Hydride Battery (NiMH)</p> <p>Battery Voltage: Nominal: 7.5 Volts Range: 6 to 9 Volts</p> <p>Recommended Battery: Medium Capacity NiCd: NTN4593** or Ultra-High Capacity NiCd: NTN4595** or Medium Capacity NiMH: NTN7014 or High Capacity NiMH: NTN7251 <i>Optional FM (Factory Mutual) Battery :</i> High Capacity FM: NTN4538*/** or Ultra-High Capacity FM: NTN4596*/**</p> <p>* FM Intrinsically Safe: Class I, II, III, Division 1, Groups D, F, and G ** FM Nonincendive: Class I, Division 2, Groups A, B, C, and D</p> <p>Dimensions (H x W x D) Note: 2.64" = width at PTT; 2.94" = width at top</p> <p>Less Battery: 5.20" x 2.64"/2.94" x 1.23" (131.32mm x 67.05/74.67mm x 31.24mm)</p> <p>With Medium Capacity NiCd Battery: 8.34" x 2.94" x 1.28" (211.82mm x 74.67mm x 31.24mm)</p> <p>With Ultra-High Capacity NiCd Battery: 9.10" x 2.94" x 1.23" (231.12mm x 74.67mm x 31.24mm)</p> <p>With High Capacity NiMH Battery: 8.34" x 2.94" x 1.23" (211.82mm x 74.67mm x 31.24mm)</p> <p>Weight: (w/Helical Antenna) Less Battery: 12.8oz. (366gm) With Medium Cap. NiCd : 26.81oz. (759gm) With Ultra-High Cap. NiCd: 29.95oz. (849gm) With High Cap. NiMH: 26.3oz. (746gm)</p>	<p>Frequency Range: 403-520MHz</p> <p>Bandwidth: 70MHz Max.</p> <p>Quieting Sensitivity (20dBQ): 0.5µV Max.</p> <p>Usable Sensitivity (12dB SINAD): 0.35µV Max.</p> <p>Intermodulation: -70dB</p> <p>Selectivity (25kHz Adjacent Channel): -70dB</p> <p>Spurious Rejection: 450-512MHz -70dB 512-520MHz -65dB</p> <p>Frequency Stability (-30 to +60°C; 25°C reference): ± .00025%</p> <p>Rated Audio: 500mW</p> <p>Distortion (At Rated Audio): 3% Typical</p> <p>Channel Spacing: 25kHz</p>	<p>RF Power: 450-512MHz 1Watt/4 Watts 512-520MHz 1Watt/3 Watts</p> <p>Frequency Range: 450-520MHz†</p> <p>Frequency Stability (-30 to +60°C; 25°C ref.): ± .00025%</p> <p>Emission (Conducted and Radiated): -66dBw</p> <p>FM Hum and Noise (Companion Receiver): -45dB Typical</p> <p>Distortion: 3% Typical</p> <p>Modulation Limiting: ±5kHz</p> <p>Emissions Designators: 20K0F1E, 16K0F3E, 15K0F2D, 15K0F1D, and 8K10F1E</p>

Specifications subject to change without notice.

SPECIFICATIONS FOR 800MHz RADIOS

All specifications are per Electronic Industries Association (EIA) 316B unless otherwise noted.

GENERAL	RECEIVER	TRANSMITTER
FCC Designation: AZ489FT5750	Frequency Range: 851–870MHz	RF Power: 3 Watts
Temperature Range:	Bandwidth: 19MHz	Frequency Range: 806–825MHz
Operating: –30°C to +60°C	Quieting Sensitivity (20dBQ): 0.5µV Max.	851–870MHz
Storage: –40°C to +85°C	Usable Sensitivity (12dB SINAD): 0.35µV Max.	Frequency Stability (–30 to +60°C; 25°C ref.): ± .00015%
Power Supply: Nickel-Cadmium Battery (NiCd) or Nickel-Metal-Hydride Battery (NiMH)	Intermodulation: –70dB	Emission (Conducted and Radiated): –46dBw
Battery Voltage:	Selectivity (25kHz Adjacent Channel): –70dB	FM Hum and Noise (Companion Receiver): –40dB
Nominal: 7.5 Volts	Spurious Rejection: –70dB	Distortion: 3% Typical
Range: 6 to 9 Volts	Frequency Stability (–30+60°C; 25°C reference): ±.00015%	Modulation Limiting: ±5kHz (821–824MHz): ±4kHz
Recommended Battery:	Rated Audio: 500mW	Emissions Designators: 20K0F1E, 16K0F3E, 15K0F2D, 15K0F1D, and 8K10F1E
Medium Capacity NiCd: NTN4593**	Distortion (At Rated Audio): 3% Typical	
or Ultra-High Capacity NiCd: NTN4595**	Channel Spacing: 25kHz	
or Medium Capacity NiMH: NTN7014		
or High Capacity NiMH: NTN7251		
<i>Optional FM (Factory Mutual) Battery:</i>		
High Capacity FM: NTN4538**		
or Ultra-High Capacity FM: NTN4596**		
* FM Intrinsically Safe: Class I, II, III, Division 1, Groups D, F, and G		
** FM Nonincendive: Class I, Division 2, Groups A, B, C, and D		
Dimensions (H x W x D) Note: 2.64" = width at PTT; 2.94" = width at top		
Less Battery: 5.20" x 2.64"/2.94" x 1.23" (131.32mm x 67.05/74.67mm x 31.24mm)		
With Medium Capacity NiCd Battery: 8.34" x 2.94" x 1.28" (211.82mm x 74.67mm x 31.24mm)		
With Ultra-High Capacity NiCd Battery: 9.10" x 2.94" x 1.23" (231.12mm x 74.67mm x 31.24mm)		
With High Capacity NiMH Battery: 8.34" x 2.94" x 1.23" (211.82mm x 74.67mm x 31.24mm)		
Weight: (w/Helical Antenna)		
Less Battery: 12.8oz. (366gm)		
With Medium Cap. NiCd: 26.81oz. (759gm)		
With Ultra-High Cap. NiCd: 29.95oz. (849gm)		
With High Cap. NiMH: 26.3oz. (746gm)		

Specifications subject to change without notice.

SECTION I. INTRODUCTION

A. General

This manual includes all the information necessary to maintain peak product performance and maximum working-time using the board-replacement service approach. This basic level of service (board-level) is typical of some local service centers, self-maintained customers, and some distributors. Included in this manual are: radio specifications for each frequency band; a general description of ASTRO™ Digital SABER™ models; basic theory of operation; recommended test equipment, service aids, and tools; radio alignment procedures; fundamental disassembly/reassembly procedures; general maintenance recommendations; board-level troubleshooting information; functional block diagram, connector information; and an exploded view diagram with parts list of the ASTRO Digital SABER portable radio. For details on the operation of the radio or component-level troubleshooting, refer to the applicable manuals available separately. To help you with your selection, a list is provided in this manual, titled “Related Publications Available Separately.”

Throughout the text in this publication, you will notice the use of warnings, cautions, and notes. These notations are used to emphasize that safety hazards exist, and care must be taken and observed.

WARNING

An operational procedure, practice, or condition, etc., which may result in injury or death if not carefully observed.

CAUTION

An operational procedure, practice, or condition, etc., which may result in damage to the equipment if not carefully observed.

NOTE

An operational procedure, practice, or condition, etc., which is essential to emphasize.

B. Radio Description

The ASTRO Digital SABER radios are among the most sophisticated two-way radios available. They are available on VHF, UHF, and 800MHz bands.

One of the newest in a long line of quality Motorola products, the ASTRO Digital SABER radio provides improved voice quality across more coverage area. The digital process called “embedded signalling” intermixes system signalling information with digital voice, resulting in improved system reliability and the capability of supporting a multitude of advanced features. Such features add up to better, more cost-effective two-way radio communications.

ASTRO Digital SABER radios are available in three basic models. Table 1 provides a description of their basic features.

C. FLASHport™

The ASTRO Digital SABER radio utilizes Motorola’s revolutionary FLASHport technology. FLASHport makes it possible to add software that drives the radio’s capabilities both at the time of purchase and later on. Previously, changing a radio’s features and capabilities meant significant modifications, or buying a new radio. But now, similar to how a computer can be loaded with different software, the radio’s features and capabilities can be upgraded with FLASHport software.

Table 1. ASTRO Digital SABER Basic Features

Feature	Model I	Model II	Model III
Display	none	2 lines/ 14 characters per line LCD	2 lines/ 14 characters per line LCD
Keypad	none	3 x 2 button	3 x 6 button
Channel Capability	16/32	255	255
Dialing From Prestored List	not available	available	available
Programmable Soft Keys	not available	available	available

SECTION II. BASIC MAINTENANCE

A. Introduction to This Section

This section of the manual describes preventive maintenance, handling precautions, and some basic repair procedures and techniques. Each of these topics provides information vital to the successful operation and maintenance of your radio.

B. Preventive Maintenance

The ASTRO Digital SABER radios do not require a scheduled preventive maintenance program; however, periodic visual inspection and cleaning is recommended.

1. Inspection

Check that the external surfaces of the radio are clean, and that all external controls and switches are functional. A detailed inspection of the interior electronic circuitry is not needed.

2. Cleaning

The following procedures describe the recommended cleaning agents and the methods to be used when cleaning the external and internal surfaces of the radio. External surfaces include the front cover, housing assembly, and battery case. These surfaces should be cleaned whenever a periodic visual inspection reveals the presence of smudges, grease, and/or grime. Internal surfaces should be cleaned only when the radio is disassembled for servicing or repair.

The only recommended agent for cleaning the external radio surfaces is a 0.5% solution of a mild dishwashing detergent, such as JOY®, in water. The only factory recommended liquid for cleaning the printed circuit boards and their components is isopropyl alcohol (70% by volume).

CAUTION

The effects of certain chemicals and their vapors can have harmful results on certain plastics. Aerosol sprays, tuner cleaners, and other chemicals should be avoided.

a. Cleaning External Plastic Surfaces

(The detergent-water solution should be applied sparingly with a stiff, non-metallic, short-bristled brush to work all loose dirt away from the radio. A soft, absorbent, lintless cloth or tissue should be used to remove the solution and dry the radio. Make sure that no water remains entrapped near the connectors, cracks, or crevices.

b. Cleaning Internal Circuit Boards and Components

Isopropyl alcohol may be applied with a stiff, non-metallic, short-bristled brush to dislodge embedded or caked materials located in hard-to-reach areas. The brush stroke should direct the dislodged material out and away from the inside of the radio.

Alcohol is a high-wetting liquid and can carry contamination into unwanted places if an excessive quantity is used. Make sure that controls or tunable components are not soaked with the liquid. Do not use high-pressure air to hasten the drying process, since this could cause the liquid to puddle and collect in unwanted places.

Upon completion of the cleaning process, use a soft, absorbent, lintless cloth to dry the area. Do not brush or apply any isopropyl alcohol to the frame, front cover, or back cover.

NOTE

Always use a fresh supply of alcohol and a clean container to prevent contamination by dissolved material (from previous usage).

C. Handling Precautions

Complementary metal-oxide semiconductor (CMOS) devices, and other high-technology devices, are used in this family of radios. While the attributes of these devices are many, their characteristics make them susceptible to damage by electrostatic discharge (ESD) or high-voltage charges. Damage can be latent, resulting in failures occurring weeks or months later. Therefore, special precautions must be taken to prevent device damage during disassembly, troubleshooting, and repair. Handling precautions are mandatory for this radio, and are especially important in low-humidity conditions. DO NOT attempt to disassemble the radio without observing the following handling precautions.

1. Eliminate static generators (plastics, Styrofoam, etc.) in the work area.
2. Remove nylon or double-knit polyester jackets, roll up long sleeves, and remove or tie back loose hanging neckties.
3. Store and transport all static-sensitive devices in ESD-protective containers.
4. Disconnect all power from the unit before ESD-sensitive components are removed or inserted unless otherwise noted.

5. Use a static-safeguarded workstation, which can be accomplished through the use of an anti-static kit (Motorola part number 01-80386A82). This kit includes a wrist strap, two ground cords, a static-control table mat and a static-control floor mat. For additional information, refer to Service and Repair Note SRN-F1052, "Static Control Equipment for Servicing ESD Sensitive Products," available from Literature Distribution.

Motorola
Literature Distribution
2290 Hammond Drive
Schaumburg, IL 60173
(708) 576-2826

When these items are not readily available, observing the following techniques will minimize chance of damage.

- If a static-sensitive device is to be temporarily set down, use a conductive surface for placement of the device.
 - Make skin contact with a conductive work surface first and maintain this contact when the device is set down or picked up.
6. Always wear a conductive wrist strap when servicing this equipment. The Motorola part number for a replacement wrist strap that connects to the table mat is 42-80385A59.

SECTION III. RECOMMENDED TEST EQUIPMENT, SERVICE AIDS, AND TOOLS

A. Recommended Test Equipment

The list of equipment contained in Table 2 includes all of the standard test equipment required for servicing two-way portable radios, as well as several unique items designed specifically for servicing this family of

radios. The "Characteristics" column is included so that equivalent equipment may be substituted; however, when no information is provided in this column, the specific Motorola model listed is either a unique item or no substitution is recommended.

Table 2. Recommended Test Equipment

Motorola Model Number	Description	Characteristics	Application
R2600	System Analyzer	This monitor will substitute for items with an asterisk (*).	Frequency/deviation meter and signal generator for wide-range troubleshooting and alignment
R1049A*	Digital Multimeter		Recommended for ac/dc voltage and current measurements
R1150C*	Code Synthesizer		Injection of audio and digital signalling codes
S1053D* SKN6008A* SKN6001A*	AC Voltmeter Power Cable for Meter Test Leads for Meter	1mV to 300V, 10-Megohm input impedance	Audio voltage measurements
R1094A	Dual-Trace Oscilloscope	20MHz bandwidth 5mV to 5V/division	Waveform measurements
S1350C* ST1213B (VHF)* ST1223B (UHF)*	Wattmeter Plug-In Element RF Dummy Load	50-ohm, ±5% accuracy 10 watts, maximum 0-1000MHz, 300W	Transmitter power output measurements
R1065	Load Resistor	10-watt Broadband	For use with wattmeter
S1339A	RF Millivolt Meter	100µV to 3V RF 10kHz to 1.2GHz	RF-level measurements
R1013A*	SINAD Meter		Receiver sensitivity measurements
S1347D or S1348D (programmable)	DC Power Supply	0-20Vdc, 0-5 Amps current limited	Bench supply for 7.5Vdc

* Any of the R2600 series system analyzers will substitute for items with an asterisk (*).

B. Service Aids and Recommended Tools

Refer to the following tables, "Service Aids for Board-Level Troubleshooting" and "Recommended Test Tools for Board-Level Troubleshooting," for a listing and description of the service aids and tools designed specifically for servicing this family of radios, as well as the more common tools required to disassemble and properly maintain the radio. These kits and/or parts are available from the Motorola Parts Division offices listed in the "Replacement Parts Ordering" section located on the inside back cover of this manual.

The following table lists service aids recommended for working on this family of radios. While all of these items are available from Motorola, most are standard shop equipment items, and any equivalent item capable of the same performance may be substituted for the item listed.

C. Field Programming Equipment

This family of radios can be aligned and programmed in the field. This requires specific equipment and special instructions. Refer to the applicable "Radio Service Software User's Guide" for complete field programming information.

Table 3. Service Aids for Board-Level Troubleshooting

Motorola Part Number	Description	Application
RKN-4046A	RIB/Radio/Test Set Cable	Connects radio to RTX-4005B Test Box and RIB.
RTL-4224A	Battery Eliminator	Interconnects radio to power supply.
REX-4200A (contains REN-4014A and REN-4011A)	Housing Eliminator/ Test Fixture	Provides for troubleshooting of the radio when the housing is removed. If you have REN-4011A or the REX-4194A (SABER SI™ Housing Eliminator), order REN-4014A only.
RTX-4005B or both RTX-4005A and RPX-4665A	Portable Test Set	Enables connection to the universal connector. Allows switching for radio testing.
Field Modification Kit RLN-4008B	Radio Interface Box	Enables communications between the radio and the computer's serial communications adapter.
01-80357A57	Wall-Mounted Power Supply	Used to supply power to the RIB (120 Vac).
01-80358A56	Wall-Mounted Power Supply	Used to supply power to the RIB (220 Vac).
30-80369B71 or 30-80369B72	Computer Interface Cable	Use B72 for the IBM PC AT. All other IBM models use B71. Connects the computer's serial communications adaptor to the RIB.
RVN-4100A	Radio Service Software	Software on 3-1/2 in. and 5-1/4 in. floppy disks.
58-80348B33	SMA to BNC Adaptor	Adapts radio's antenna port to BNC cabling of test equipment.

Table 4. Recommended Tools for Board-Level Troubleshooting

Motorola Part Number	Description	Application
01-80386A82	Anti-Static Grounding Kit	Used during radio assembly and disassembly procedures.
RSX-4043A	Roto-Torq Adjustable Torque Screwdriver	Used during radio assembly and disassembly procedures.
66-80370B89	Slotted-Spanner Nut Bit	Used during radio assembly and disassembly procedures.
66-80321B86	#0 Phillips Bit	Used during radio assembly and disassembly procedures.
66-80321B79	#1 Phillips Bit	Used during radio assembly and disassembly procedures.
66-80371B03	Spanner Nut Bit	Used during radio assembly and disassembly procedures.
66-80371B34	Spanner Nut Bit	Used during radio assembly and disassembly procedures.

SECTION IV. PERFORMANCE CHECKS

A. Introduction to This Section

This section covers performance checks used to verify the radio meets published specifications. The recommended test equipment listed in the previous section approaches the accuracy of the manufacturing equipment, with a few exceptions. Accuracy of the equipment must be maintained in compliance with the manufacturer's recommended calibration schedule.

B. Setup

Supply voltage can be connected from the battery eliminator. The equipment required for alignment procedures is connected as shown in the "Radio Alignment Test Setup" diagram.

Initial equipment control settings should be as indicated in the following table, and should hold for all alignment procedures except as noted in Table 5.

Table 5. Initial Equipment Control Settings

System Analyzer	Test Set	Power Supply
Monitor Mode: Pwr Mon RF Attn: -70dB AM, CW, FM: FM O'scope Source: Mod O'scope Horiz: 10mSec/Div O'scope Vert: 2.5kHz/Div O'scope Trig: Auto Monitor Image: Hi Monitor BW: Nar Monitor Squelch: mid CW Monitor Vol: 1/4 CW	Spkr set: A Spkr/load: Speaker PTT: OFF (center)	Voltage: 7.5Vdc DC on/standby: Standby Volt Range: 10Vdc Current: 2.5Amps

C. Test Mode

1. RF Test Mode

When the ASTRO Digital SABER radio is operating in its normal environment, the radio's microcomputer controls the RF channel selection, transmitter key-up, and receiver muting. However, when the unit is on the bench for testing, alignment, or repair, it is removed from its normal environment. It cannot receive commands from its system and, therefore, the internal microcomputer will not key the transmitter nor unmute the receiver. This prevents the use of normal tune-up procedures. To solve this problem a special routine, called TEST MODE or "air test," has been incorporated in the radio.

To enter the test mode:

- Turn the radio on and adjust the volume for a comfortable listening level. The volume level remains constant once in the test mode.

- Within 10 seconds after the "Self Test" is complete, press side button 3 five times in succession.
- After "RF TEST" appears, press the top programmable button (normally programmed as the emergency button) once. "1 CSQ" appears, indicating: test frequency 1, carrier squelch mode.
- Each additional press of side button 3 will advance to the next test channel. (Refer to Table 7.)
- Pressing side button 2 will scroll through and access test environments as shown in Table 6.

NOTE

Transmit into a load when keying a radio under test.

Table 6. Test Environments

Display	Description	Function
CSQ	Carrier Squelch	RX: unsquelch if carrier detected TX: mic audio
TPL	Tone Private-Line	RX: unsquelch if carrier and tone (192.8 Hz) detected TX: mic audio + tone (192.8 Hz)
AST	ASTRO	RX: none TX: 1200Hz tone *

* All deviation values are based on deviation tuning of this mode.

2. Control Top and Keypad Test Mode

To check the display, the buttons, and the switches, perform the following tests:

- Turn the radio on and adjust the volume for a comfortable listening level. The volume level remains constant once in the test mode.
- Within 10 seconds after the "Self Test" is complete, press side button 3 five times in succession.
- After "RF TEST" appears on the display, press side button 1 once, "CH TEST" (14-character radio) appears on the display.
- Next, press and hold the top programmable button; all segments on the display will light, and the LED on the control top will illuminate a red color.
- Release the top programmable button; "3/0" appears, which indicates that the top programmable button is in the open condition.

- f. Press the top programmable button again; “3/1” appears, which indicates that the top programmable button is in the closed condition.
 - g. Rotate the mode/zone selector switch; “4/0” through “4/15” appears, which indicates that the selector switch is in mode/zone position 1 through 15.
 - h. Rotate the two-position (A/B) switch; “65/0” and “65/1” appears.
 - i. Rotate the two-position programmable switch (concentric with the top programmable button); “67/3” and “67/0” appear.
 - j. Rotate the volume control; “2/0” through “2/255” appear.
 - k. Press side button 1, “96/1” appears; release, “96/0” appears.
 - l. Press side button 2, “97/1” appears; release, “97/0” appears.
 - m. Press side button 3, “98/1” appears; release, “98/0” appears.
 - n. Press the PTT switch, “1/1” appears; release, “1/0” appears.
- Keypad Checks:
- Press **0**, “48/1” appears; release, “48/0” appears.
 - Press **1**, “49/1” appears; release, “49/0” appears.
 - Press **2**, “50/1” appears; release, “50/0” appears.
 - Press **3**, “51/1” appears; release, “51/0” appears.
 - Press **4**, “52/1” appears; release, “52/0” appears.
 - Press **5**, “53/1” appears; release, “53/0” appears.
 - Press **6**, “54/1” appears; release, “54/0” appears.
 - Press **7**, “55/1” appears; release, “55/0” appears.
 - Press **8**, “56/1” appears; release, “56/0” appears.
 - Press **9**, “57/1” appears; release, “57/0” appears.
 - Press *****, “58/1” appears; release, “58/0” appears.
 - Press **#**, “59/1” appears; release, “59/0” appears.
 - Press **◀**, “128/1” appears; release, “128/0” appears.
 - Press **HOME**, “129/1” appears; release, “129/0” appears.
 - Press **▶**, “130/1” appears; release, “130/0” appears.
 - Press the left-hand • key on the top row of keys, “131/1” appears; release, “131/0” appears.
 - Press the center • key, “132/1” appears; release, “132/0” appears.
 - Press the right-hand • key, “133/1” appears; release, “133/0” appears.

Table 7. Test Frequencies

Test Channel	VHF	UHF Band 1	UHF Band 2	800MHz
TX #1	136.025	403.100	450.025	806.0125
RX #1	136.075	403.150	450.075	851.0625
TX #2	142.125	424.850	465.225	815.0125
RX #2	142.075	424.900	465.275	860.0625
TX #3	154.225	438.050	475.225	824.9875
RX #3	154.275	438.100	475.275	869.9375
TX #4	160.125	444.050	484.975	851.0125
RX #4	160.175	444.100	485.025	851.0625
TX #5	168.075	456.350	500.275	860.0125
RX #5	168.125	456.400	500.225	860.0625
TX #6	173.975	463.700	511.975	869.9875
RX #6	173.925	463.750	511.925	869.9375
TX #7	177.975	469.650	519.975	None
RX #7	177.925	469.700	519.925	None

Table 8. Receiver Performance Checks

Test Name	System Analyzer	Radio	Test Set	Comments
Reference Frequency	Mode: PWR MON 4th channel test frequency* Monitor: Frequency error Input at RF In/Out	TEST MODE, 4 CSQ output at antenna	PTT to continuous (during the performance check)	Frequency error to be $\leq \pm 600\text{Hz}$
Rated Audio	Mode: GEN Output level: 1.0mV RF 4th channel test frequency* Mod: 1kHz tone at 3kHz deviation Monitor: DVM: ac Volts	TEST MODE, 4 CSQ	PTT to OFF (center), meter selector to Audio PA	Set volume control to 3.74Vrms
Distortion	As above, except to distortion	As above	As above	Distortion < 3.0%
Sensitivity (SINAD)	As above, except SINAD, lower the RF level for 12dB SINAD	As above	PTT to OFF (center)	RF input to be < 0.35 μV
Noise Squelch Threshold (only radios with conventional system need to be tested)	RF level set to 1mV RF	As above	PTT to OFF (center), meter selection to Audio PA, spkr/load to speaker	Set volume control to 3.74Vrms
	As above, except change frequency to a conventional system. Raise RF level from zero until radio unsquelches.	Out of TEST MODE; select a conventional system	As above	Unsquelch to occur at < 0.25 μV Preferred SINAD = 8-10dB

* (See Table 7.)

Table 9. Transmitter Performance Checks

Test Name	System Analyzer	Radio	Test Set	Comments
Reference Frequency	Mode: PWR MON 4th channel test frequency❖ Monitor: Frequency error Input at RF In/Out	TEST MODE, 4 CSQ	PTT to continuous (during the performance check).	Frequency error to be $\leq \pm 600\text{Hz}$.
Power RF	As above	As above, 4 CSQ	As above	Refer to Maintenance Specifications page in front of manual.
Voice Modulation	Mode: PWR MON 4th channel test frequency❖ atten to -70 , input to RF In/Out, Monitor: DVM, ac Volts Set 1kHz Mod Out level for 0.025Vrms at test set, 80mVrms at ac/dc test set jack	As above, 4 CSQ	As above, meter selector to mic	Deviation: VHF, UHF, and 800MHz: $\geq 3.6\text{kHz}$ but $\leq 5.0\text{kHz}$
Voice Modulation (internal)	Mode: PWR MON 4th channel test frequency❖ atten to -70 , input to RF In/Out	TEST MODE, 4 CSQ, output at antenna	Remove modulation input	Press PTT switch on radio. Say "four" loudly into the radio mic. Measure deviation: VHF, UHF, and 800MHz: $\geq 3.8\text{kHz}$ but $\leq 5.0\text{kHz}$
PL Modulation (radios with conventional, clear mode, coded squelch operation only)	Change frequency to a conventional transmit frequency, BW to narrow	Conventional coded squelch personality (clear mode operation) 4 TPL	As above	Deviation: VHF, UHF, and 800MHz: $\geq 500\text{Hz}$ but $\leq 1000\text{Hz}$
Talkaround Modulation (radios with conventional, clear mode, talk-around operation only)	Change frequency to conventional talk-around frequency. Mode: PWR MON deviation, attenuation to -70 , input to RF In/Out Monitor: DVM, ac volts Set 1kHz Mod Out level for 25mVrms at test set.	Conventional talk-around personality (clear mode operation) 1 CSQ	As above	Deviation: UHF and 800MHz: $\geq 3.8\text{kHz}$ but $\leq 5.0\text{kHz}$
Talkaround Modulation (radios with conventional, secure mode, talk-around operation only) (**)	Change frequency to conventional talk-around frequency. Mode: PWR MON deviation, attenuation to -70 , input to RF In/Out Monitor: DVM, ac volts Mod: 1kHz out level for 25mVrms at test set.	Conventional talk-around personality (secure mode operation) Load key into radio 1 sec.	As above	Deviation: UHF and 800MHz: $\geq 3.6\text{kHz}$ but $\leq 4.4\text{kHz}$

* 800MHz radios only

** The secure mode, talkaround modulation test is only required for trac mode radios which do not have clear mode talkaround capability.

❖ See Table 7.

SECTION V. RADIO ALIGNMENT PROCEDURE

A. Introduction to This Section

This section describes both receiver and transmitter radio alignment procedures.

B. General

An IBM personal computer (PC) and radio service software (RSS) are required to align the radio. Refer to the applicable RSS manual for installation and setup procedures for the software. To perform the alignment procedures, the radio must be connected to the PC, radio interface box (RIB), and a universal test set as shown in Figure 1.

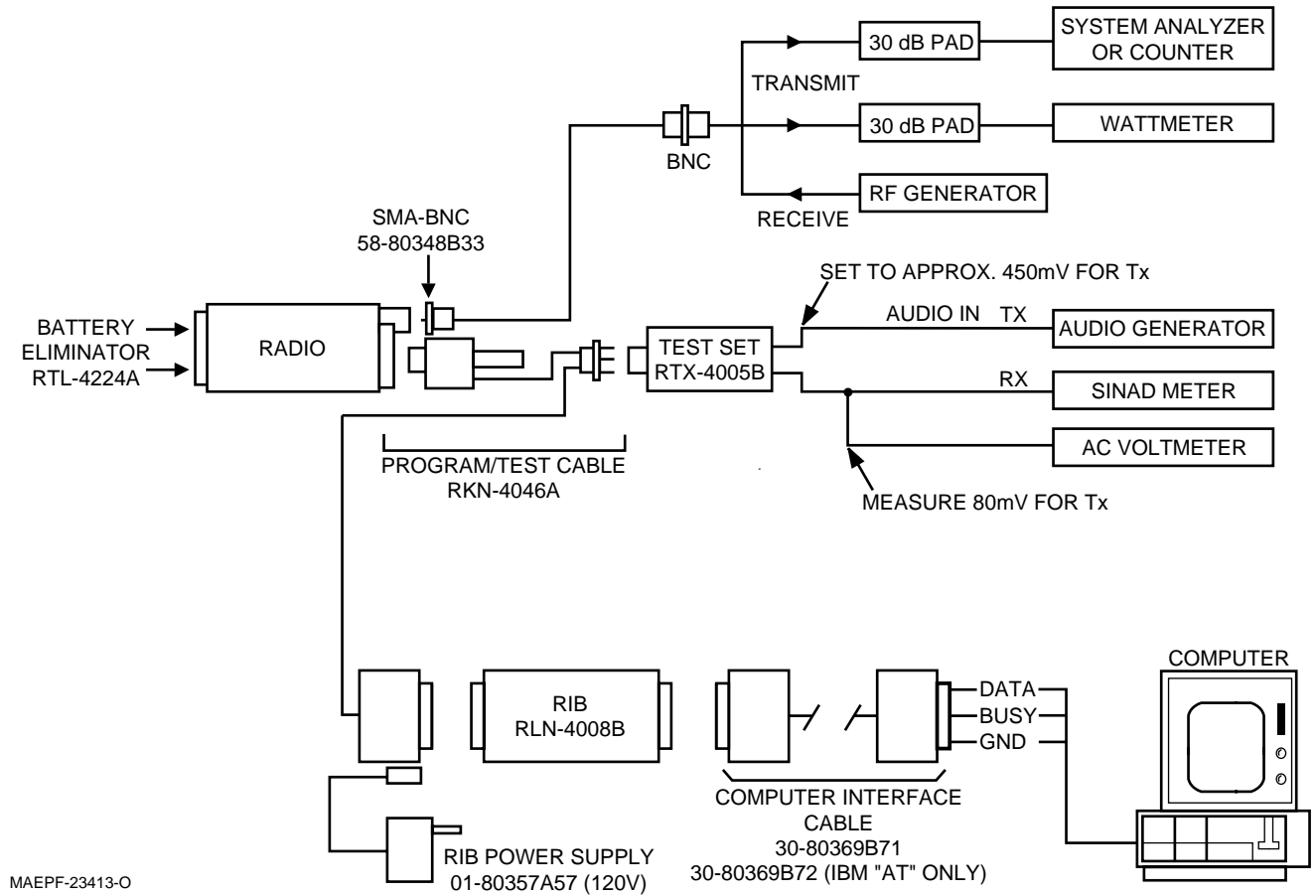

MAEPF-23413-O

Figure 1. Radio Alignment Test Setup

All service and tuning procedures are performed from the SERVICE menu, which is selected by pressing F2 from the MAIN MENU. Figure 2 illustrates how the RSS alignment SERVICE screens are organized.

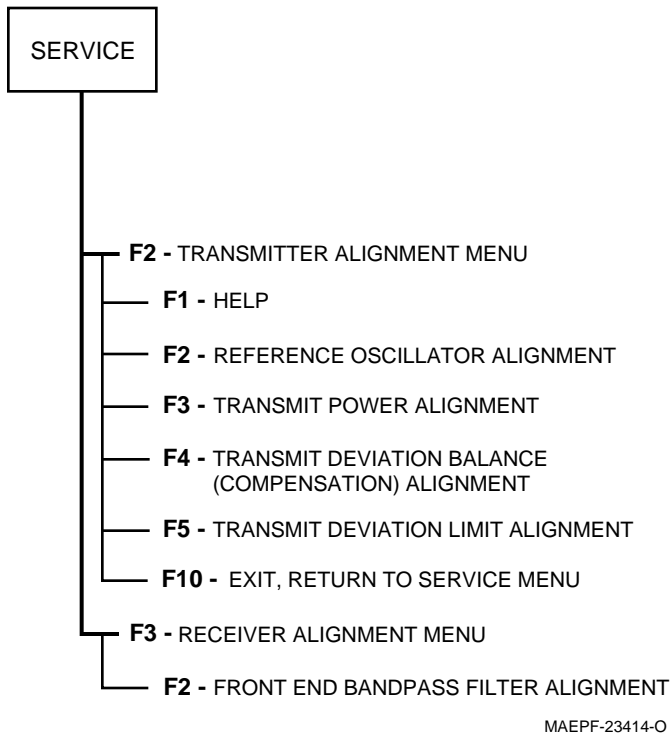

Figure 2. RSS Service Menu Layout

All SERVICE screens read and program the radio codeplug directly; you do NOT have to use the RSS GET/SAVE functions to use the SERVICE menus.

CAUTION

Do NOT switch radios in the middle of any SERVICE procedure. Always use the EXIT key to return to the MAIN menu screen before disconnecting the radio. Improper exits from the SERVICE screens may leave the radio in an improperly configured state and result in seriously degraded radio or system performance.

The SERVICE screens introduce the concept of the “softpot,” an analog SOFTWARE controlled POTentiometer used for adjusting all transceiver alignment controls.

Each SERVICE screen provides the capability to increase or decrease the ‘softpot’ value with the keyboard UP/DOWN arrow keys respectively. A graphical scale is displayed indicating the minimum, maximum, and proposed value of the softpot, as shown in Figure 3.

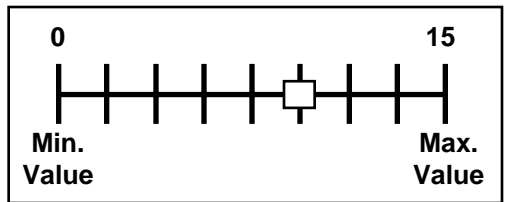

Figure 3. Softpot Concept

Adjusting the softpot value sends information to the radio to increase (or decrease) a dc voltage in the corresponding circuit. For example, pressing the UP arrow key at the Reference Oscillator screen instructs the radio’s microcomputer to increase the voltage across a varactor in the reference oscillator, which increases the frequency.

In ALL cases, the softpot value is just a relative number corresponding to a digital-to-analog (D/A) generated voltage in the radio.

Perform the following procedures in the sequence indicated.

NOTE

Some of the following screens may vary depending upon the radio under test and the version of radio service software you are using. Refer to your radio service software user's guide.

C. Reference Oscillator Alignment

Adjustment of the reference oscillator is critical for proper radio operation. Improper adjustment will result not only in poor operation, but also in a misaligned radio that will interfere with other users operating on adjacent channels. For this reason, the reference oscillator should be checked every time the radio is serviced. The frequency counter used for this procedure must have a stability of 0.1 ppm (or better).

1. From the SERVICE MENU, press **F2** to select the TRANSMITTER ALIGNMENT MENU.
2. Press **F2** again to select the REFERENCE OSCILLATOR alignment screen. See Figure 4.

3. Press **Tab** (or **Enter** or **Return**) to select a frequency field (starting with the highest frequency shown). Then, press **F6** to key the radio. The screen will indicate that the radio is transmitting.
4. Measure the transmit frequency on your service monitor.
5. Use the UP/DOWN arrow keys to adjust the reference oscillator softpot value. See Table 10.
6. Press **F6** again to dekey the radio.
7. Press **F8** to program the new softpot value.
8. Repeat steps 3-7 for the remaining frequencies.
9. Press **F10** once to return to the TRANSMITTER ALIGNMENT MENU, or press **F10** twice to return to the SERVICE MENU.

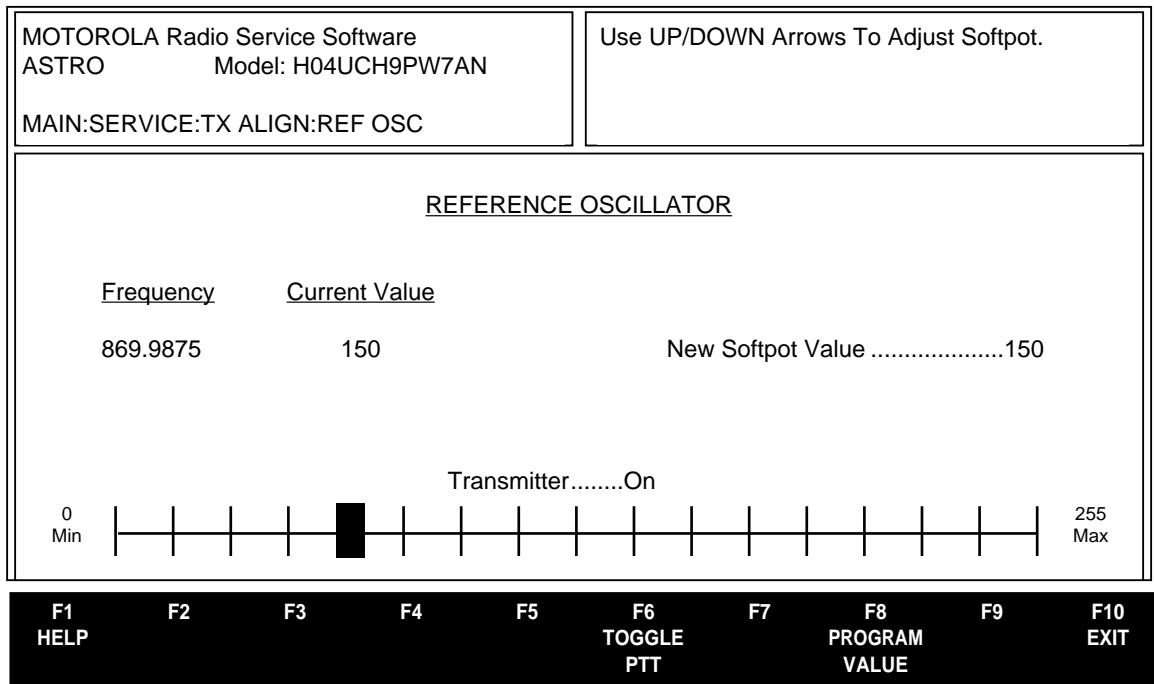

Figure 4. Reference Oscillator Alignment Screen

Table 10. Reference Oscillator Alignment

Band	Target
VHF	±150Hz
UHF	±150Hz
800MHz	±150Hz

D. Transmit Power Alignment

NOTE

- All power measurements are to be made at the antenna port.
 - The transmitter power setting keeps the radiated power at or below the level specified in the exclusionary clause for low power devices of IEEE Standard C95.1-1991.
1. From the SERVICE MENU, press **F2** to select the TRANSMITTER ALIGNMENT MENU.
 2. Press **F3** to select the TRANSMIT POWER alignment screen. The screen will indicate the transmit frequencies to be used. See Figure 5.

3. Press **Tab** (or **Enter** or **Return**) to select a frequency field (starting with the highest frequency shown). Then, press **F6** to key the radio. The screen will indicate that the radio is transmitting.
4. Use the UP/DOWN arrow keys to adjust the transmit power per the values shown in Table 11.
5. Press **F6** to dekey the radio.
6. Press **F8** to program the value.
7. Repeat steps 3-6 for the remaining frequencies.
8. Press **F10** once to return to the TRANSMITTER ALIGNMENT MENU, or press **F10** twice to return to the SERVICE MENU.

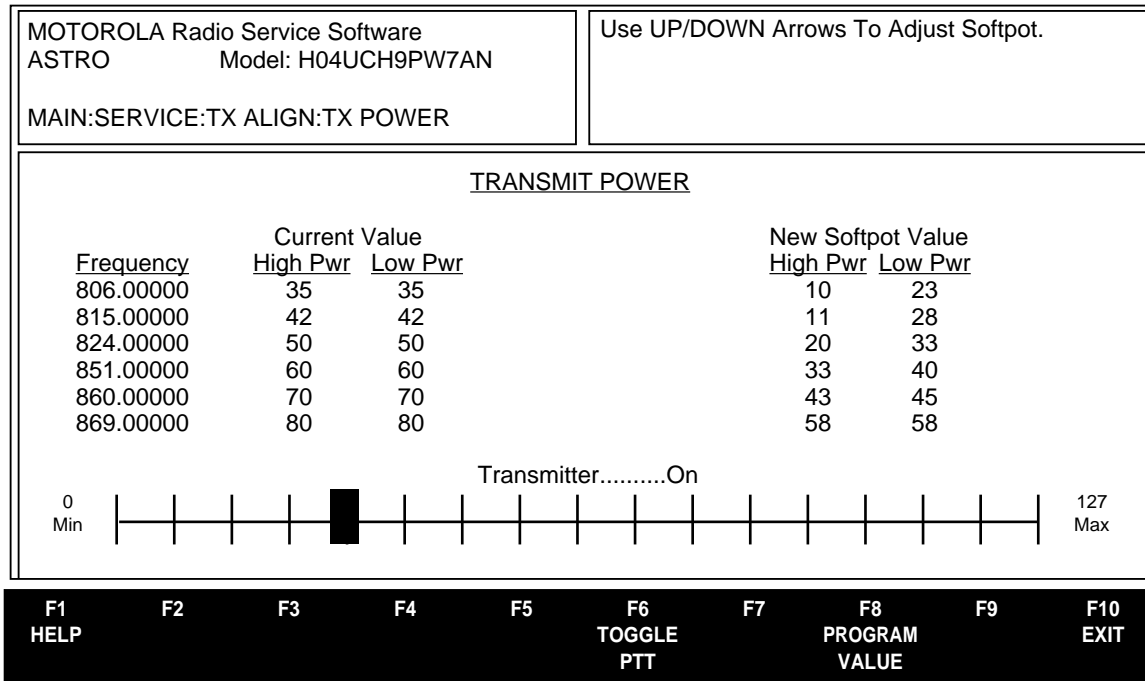

Figure 5. Transmit Power Alignment Screen

Table 11. Transmit Power Setting

VHF Power Level	Test Frequencies	
	136-174MHz	174-178MHz
1W	1.2 -1.4	1.2 - 1.4
5W	5.2 - 5.4	4.2 - 4.4
UHF Power Level	Test Frequencies	
	450-512MHz	512-520MHz
1W	1.2 -1.4	1.2 - 1.4
4W	4.2 - 4.4	3.2 - 3.4
800MHz Power Level	All Test Frequencies	
3W	3.2 -3.4	

E. Transmit Deviation Balance (Compensation) Alignment

Compensation alignment balances the modulation sensitivity of the VCO and reference modulation (synthesizer low-frequency port) lines. The compensation algorithm is critical to the operation of signalling schemes that have very-low-frequency components (for example, DPL) and could result in distorted waveforms if improperly adjusted.

1. From the SERVICE MENU, press **F2** to select the TRANSMITTER ALIGNMENT MENU.
2. Press **F4** to select the TRANSMIT DEVIATION BALANCE (COMPENSATION) alignment screen. The screen will indicate the transmit frequencies to be used. See Figure 6.
3. Press **Tab** (or **Enter** or **Return**) to select a frequency field (starting with the lowest frequency shown).
4. Press **F4**. This will cause the radio to key and the radio's DSP IC to inject an 80Hz tone into the RF board.
5. Measure the deviation and record this value.
6. Press **F4** to dekey the radio.
7. Press **F6**. This will cause the radio's DSP IC to change the injection tone to 3kHz, 100mVrms. Use the UP/DOWN arrow keys to adjust the deviation to within $\pm 2\%$ of the value recorded in step 5.
8. Repeat steps 4-7 until the 3kHz tone deviation is within $\pm 2\%$ of the 80Hz tone deviation.
9. Press **F6** again to dekey the radio.
10. Press **F8** to program the new softpot value.
11. Repeat steps 3-10 for the remaining frequencies.
12. Press **F10** once to return to the TRANSMITTER ALIGNMENT MENU, or press **F10** twice to return to the SERVICE MENU.

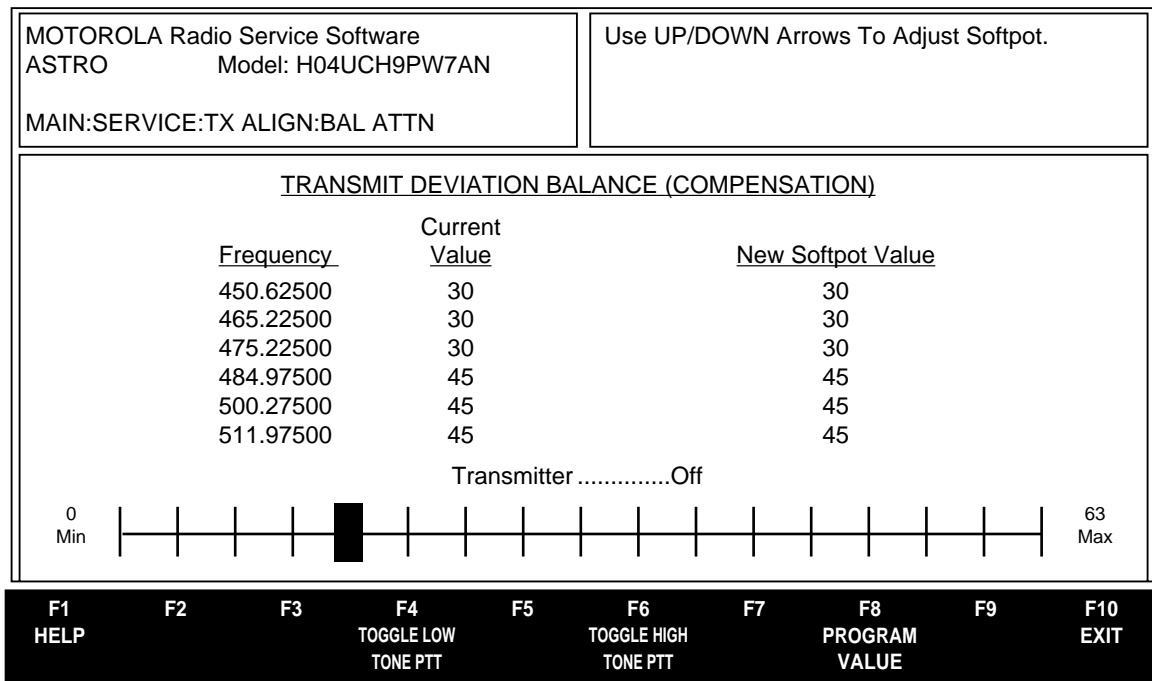

Figure 6. Transmit Deviation Balance (Compensation) Alignment Screen

F. Transmit Deviation Limit Alignment

IMPORTANT NOTE

Put the radio in the RF test mode and scroll to the ASTRO test environment, indicated by "AST" on the display (refer to the "Performance Checks" section for details). All other deviation values are derived from the ASTRO test environment mode transmit deviation limit.

1. From the SERVICE MENU, press **F2** to select the TRANSMITTER ALIGNMENT MENU.
2. Press **F5** to select the TRANSMIT DEVIATION LIMIT alignment screen. The screen will indicate the transmit frequencies to be used. See Figure 7.
3. Press **Tab** (or **Enter** or **Return**) to select a frequency field (starting with the lowest frequency shown).
4. Press **F6** to key the radio. Then use the UP/DOWN arrow keys to adjust for a deviation per the values shown in Table 12.
5. Press **F6** again to dekey the radio.
6. Press **F8** to program the softpot value.
7. Repeat steps 3-6 for the remaining frequencies.
8. Press **F10** once to return to the TRANSMITTER ALIGNMENT MENU, or press **F10** twice to return to the SERVICE MENU.

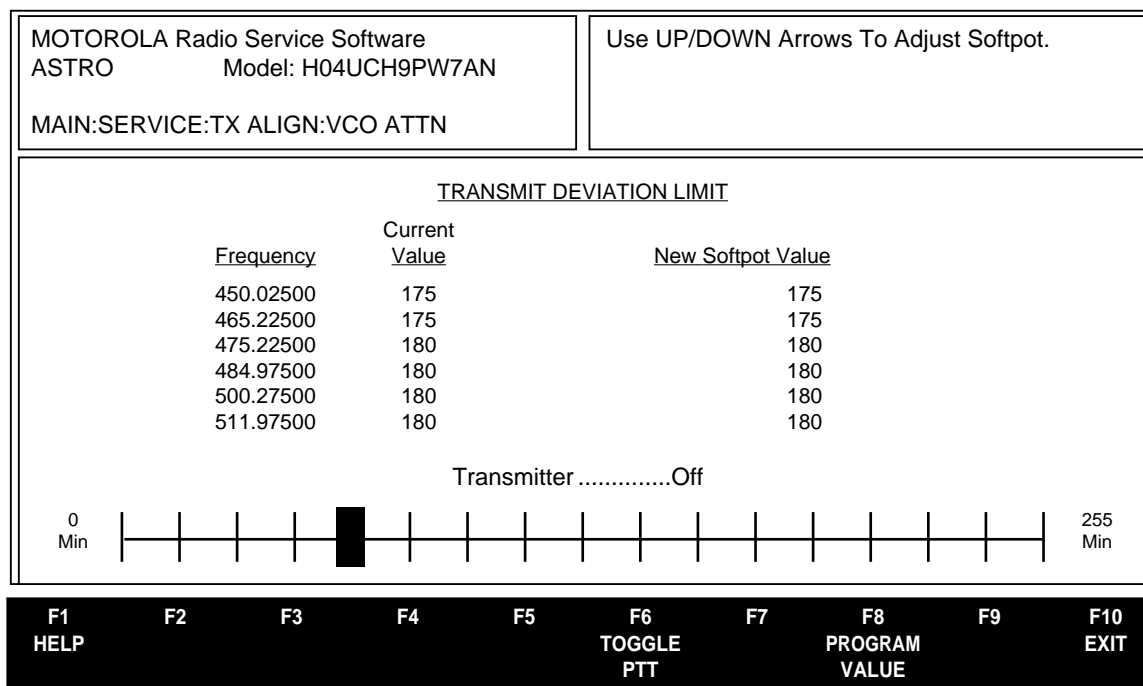

Figure 7. Transmit Deviation Limit Alignment Screen

Table 12. Transmit Deviation Limit

Band	Deviation (Hz)
VHF	2785-2885
UHF	2785-2885
800MHz	2785-2885

G. Front-End Filter Alignment (VHF/UHF Only)

NOTE

This procedure is only required for tuning the front-end filter varactors in the VHF and UHF models. The 800MHz models utilize a fixed front-end filter.

1. From the SERVICE MENU, press **F3** to select the RECEIVER ALIGNMENT MENU.
2. Press **F2** to select the FRONT END FILTER ALIGNMENT screen. The screen will indicate the receive frequencies at which the filter is to be aligned. See Figure 8.
3. Press **Tab** (or **Enter** or **Return**) to select a frequency field.
4. Set the RF test generator to the first receive frequency +150Hz. Set the RF level at the radio standard antenna port to 4.0μV with no modulation.
5. Adjust the UP/DOWN arrow keys to obtain a peak value in the RSSI (receive signal strength indicator) field. Note **F4** must be pressed to obtain each RSSI reading after adjustment.
6. Press **F8** to program the new softpot value.
7. Repeat steps 3-6 for the remaining frequencies.
8. Press **F10** once to return to the RECEIVER ALIGNMENT MENU, or press **F10** twice to return to the SERVICE MENU.

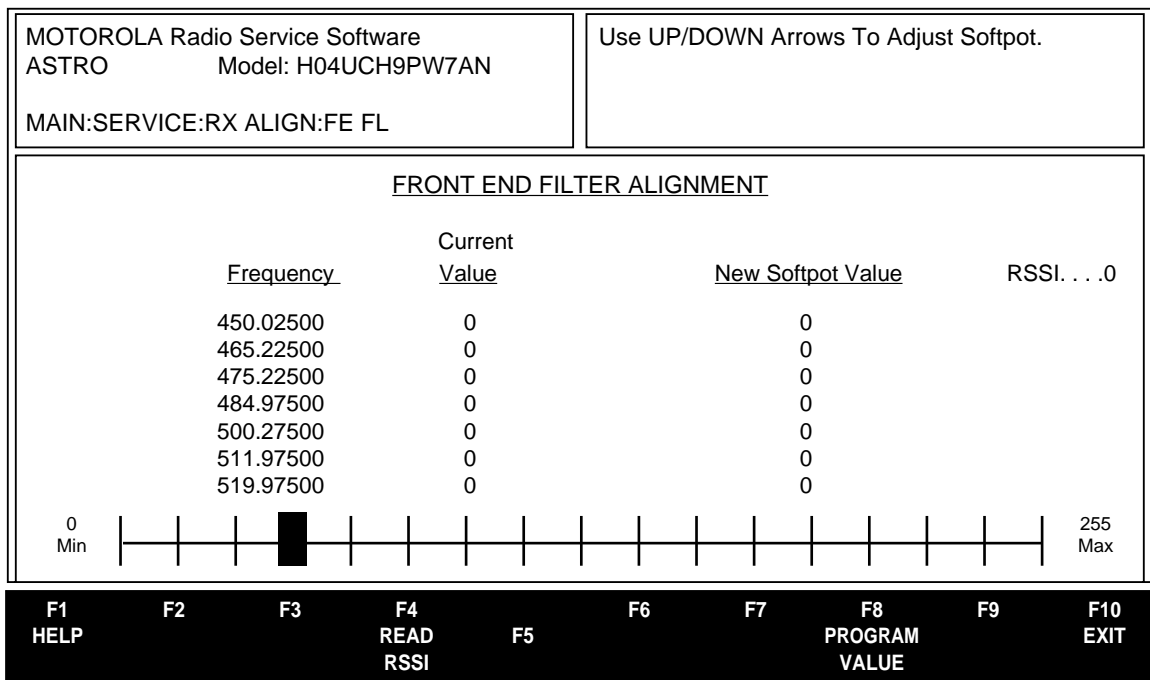

Figure 8. Front-End Filter Alignment Screen

SECTION VI. DISASSEMBLY/REASSEMBLY PROCEDURES

CAUTION

Before attempting any disassembly or reassembly of the radio, observe the handling precautions described in the "Basic Maintenance" section of this manual.

A. Disassembly

(Refer to the following diagrams and the exploded view diagram located in the back of this manual.)

1. Turn off the radio by rotating the on/off/volume control fully counterclockwise until you hear a click. Remove the accessory connector cover or any accessory connected to the radio before beginning disassembly.

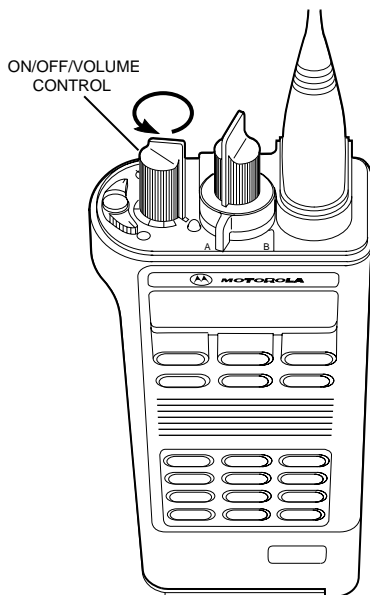

MAEPF-23372-O

2. Remove the **battery** from the baseplate on the bottom of the radio housing by pushing the spring-loaded battery latch toward the top of the radio, and sliding the battery away from the latch until it clears the baseplate.

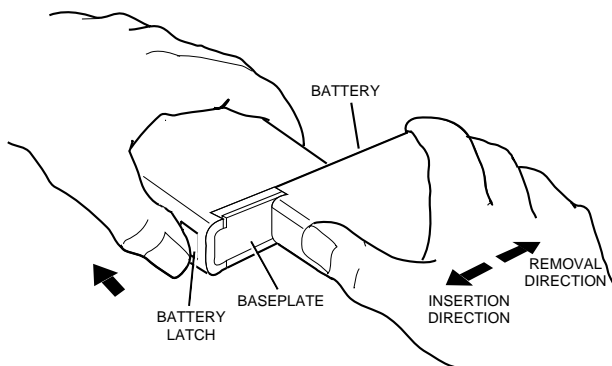

MAEPF-20185-O

3. Loosen the two **slotted-spanner nuts** on the bottom of the radio using the ROTO-TORQ adjustable torque screwdriver with bit No. 66-80370B89. When loosened, the slotted-spanner nuts are captive and will spin freely without separating from the baseplate.

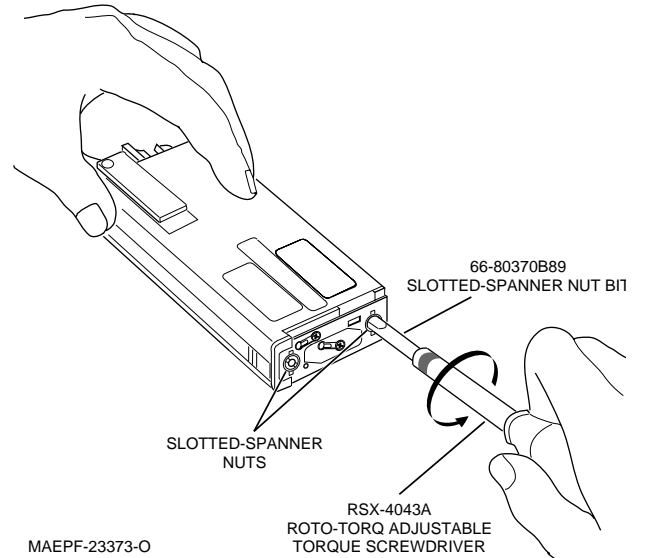

MAEPF-23373-O

4. Remove the **chassis** from the radio housing by grasping the antenna at its base and pulling it gently upward. Do not depress the PTT switch during removal and do not push on the slotted-spanner nuts to remove the chassis.

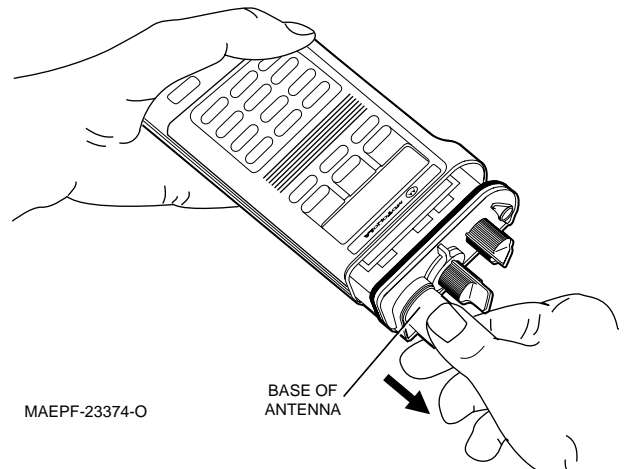

MAEPF-23374-O

- Gently push the center bottom edge of the **front shield assembly** and lift it away from the bottom of the chassis. If necessary, use a small slotted screwdriver to disengage the two retaining clips near the bottom outer edges. Next, pull the front shield assembly out from under the plastic top panel. Be careful not to pull against the flexible circuits connecting to the controller board.

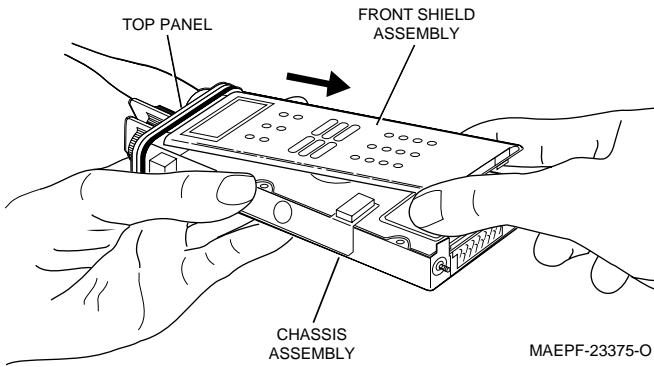

- Disconnect the **display flexible circuit (Models II and III only)** and the **speaker/microphone flexible circuit** from the controller board by pulling the respective connector plugs out and away from the controller board and shield assembly. The connector plugs are covered with a protective rubberized pad. Also, disconnect the **control top/PTT flexible circuit** from the controller board by pulling up and rotating the flex connector plug out and away from the controller board and shield assembly. The connector plug is covered with a protective rubberized pad.

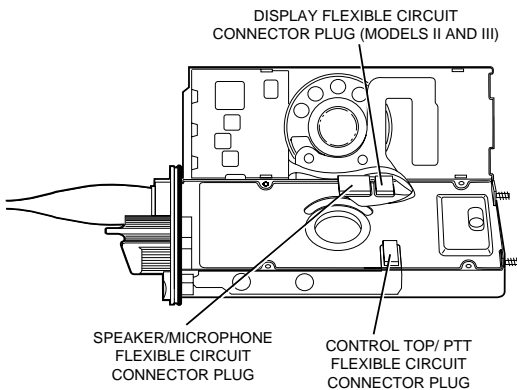

- Using a ROTO-TORQ adjustable screwdriver tool with a Phillips bit #0 point size (Motorola part number 66-80321B86), remove the four controller shield screws. Next, gently pry the **controller shield** up and out of the chassis by inserting the tip of a thin slotted screwdriver between the chassis and the controller shield at each of the three thin-walled chassis points (see diagram below).

CAUTION

To avoid damage to the control top/PTT flexible circuit, **DO NOT** insert the screwdriver tip near the flexible circuit connector or the dual-function switch. Insert the tip of the slotted screwdriver only at the thin-walled chassis points shown below.

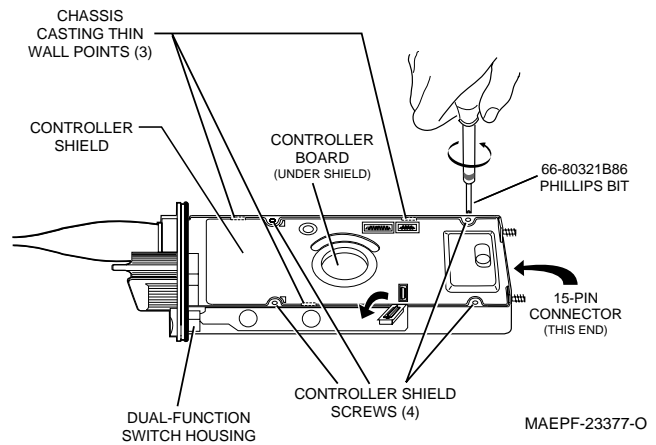

After the controller shield is freed, remove the **controller board** from the chassis by gently applying upward pressure on the black 15-pin connector.

8. Remove the **center shield** from the chassis by inserting a thin slotted screwdriver between each of five center-shield release clips and the corresponding chassis-retaining tabs.

CAUTION

Use extreme caution to ensure that the release clips are only deflected enough to disengage the clip from the chassis. Too much pressure on the clips could permanently damage the retaining feature.

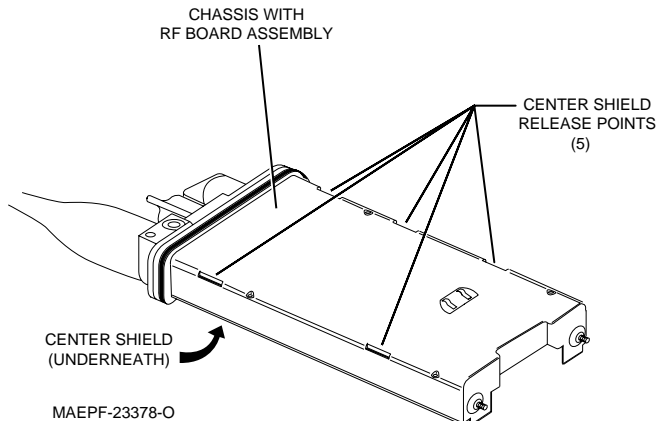

Once freed from the chassis at the five release points, the center shield can be removed and the **RF board** can be removed from the chassis.

CAUTION

The RF and ground contacts at the top of the RF board are exposed when the board is removed from the chassis. Special care must be taken to avoid accidental damage to these contacts.

B. Servicing Major Subassemblies

Refer to the exploded view diagram at the back of this manual before attempting further disassembly or repair.

1. Baseplate

- All repairs to the baseplate assembly can, and should, be made with the radio chassis inside the radio.
- After the slotted-spanner nuts are loosened, the baseplate is held in place by the power contact screw.
- The retainers holding the slotted-spanner nuts in place are not reusable. Replacement of the retainers requires special insertion procedures; refer to the instruction sheet provided with the slotted-spanner nut kit.
- The "O-ring" portion of the elastomer seal must be fully seated on the threaded bushing before the baseplate is reassembled (the bushing is part of the housing assembly).

2. Housing Assembly

- The housing assembly includes many parts that are not replaceable or repairable.
- The insulator on the universal connector can, and should, be replaced if the old insulator has been torn. When replacing the insulator take care to keep it out of the main-seal O-ring's seating area.
- The PTT lever can be replaced by prying out the old part with a soft plastic tool. The plastic housing around the lever may be damaged if a harder tool is used.

3. Control Top Panel

The control top panel is fastened to the chassis by the on/off/volume control, mode/zone selector switch, programmable switch, and antenna switch; it should be removed from the chassis only if absolutely necessary.

4. Front Shield/Display Board Assembly

The ASTRO Digital SABER radio's display board can be replaced, but the comments and cautions in this manual must be strictly followed. To remove the display board from the front shield assembly:

- a. ensure that all static safeguards are in effect;
- b. turn the front shield/display board assembly face down;
- c. with slight upward pressure on the LCD bezel, bend back each of the two plastic tabs that hold the display board in place, and the bottom of the LCD will come loose;
- d. push the LCD from its secured position enough to grasp its edges, then pull firmly up and out on the front shield/display board assembly.

CAUTION

Be very careful not to damage the keyswitch overlay which is adhesively attached to the LCD bezel.

5. Chassis

If you must lift or remove the control top/PTT flexible circuit for any reason, do not re-adhere it to the chassis; the flexible circuit must be replaced.

6. Dual-Function Switch and Actuator Assembly

- Before removing the switch, remove the knob by gently separating the two arms of the switch bracket (located between the switch and the main O-ring seal) and pulling upward on the knob.
- Before re-inserting the knob, ensure that the slot in the switch is properly aligned with the blade on the knob's shaft.

- When the knob is properly inserted, the arms of the switch bracket will snap into position (approximately 0.2 inches apart), the knob will not be loose in the switch bracket, and the bracket will hold the switch firmly against the inside of the top control panel. If this is not the case, replace the switch bracket.

C. Reassembly

Reassemble the radio in the reverse order of disassembly, referring to "Servicing Major Subassemblies" (paragraph B) and making certain:

1. that the protruding block that functions as the PA heatsink (inside back casting), is coated with a thin film of thermal compound (Motorola part number 11-10022A55), which helps provide maximum heat transfer;
2. that the RF board is properly seated in the chassis, and that when inserted, the five locking tabs on the center shield are engaged with the chassis;
3. that when the controller board is reinstalled over the center shield and mated to the RF board, the connector plug of the controller is pressed firmly into the connector jack of the RF board (the two boards should snap together);
4. that when installed, the four controller shield screws are torqued per specifications;
5. that the control top/PTT flex plug, speaker/microphone flex plug, and display flex plug have all properly mated with their corresponding connector jacks;
6. that the keyswitch overlay is pressed firmly against the LCD metal bezel of the front shield assembly;
7. that there is no foreign material on the main O-ring or stud seals;
8. to properly orient the completed chassis assembly before inserting it into the radio housing;
9. that the PTT switch and monitor button are not depressed while the chassis is being inserted into the housing;
10. that the slotted-spanner nut closest to the battery latch is torqued first, then torque the other to the proper specification listed in Table 13.

CAUTION

Inspect the chassis stud seals and the control top panel O-ring and replace if any damage exists.

Table 13. Torque Specifications

Application	Torque (in -lbs)	Torque (N•m)	Torque Bit Part No.
RX/TX Switch Spanner Nut	20	2.27	66-80371B34
Frequency Switch Spanner Nut	8	0.91	66-80371B03
Power Contact Screws	2.5	0.28	66-80321B79
Slotted-Spanner Nut (Baseplate)	6	0.68	66-80370B89
Volume Pot Spanner Nut	8	0.91	66-80371B03
Controller Shield Screws	2.8	0.32	66-80321B86

SECTION VII. BASIC THEORY OF OPERATION

A. Introduction to This Section

The following theory will help isolate the problem to a particular board. Using circuit board replacement as the basic service approach will maximize working-time of the radio.

B. General Overview

The ASTRO Digital SABER radio is a wideband, synthesized, fixed-tuned radio available in the VHF, UHF, and 800MHz bands. All ASTRO Digital SABER radios are capable of both analog operation and ASTRO mode (digital) in 12.5kHz or 25kHz bandwidths.

The ASTRO Digital SABER radio consists of four major assemblies. They are:

- **Controller Board** - contains the microcontrol unit (MCU) and its associated memory and memory management integrated circuit (IC), the digital signal processor and its associated memories and support IC, the audio power amplifier, and a switching regulator.
- **RF Board** - contains all transmit, receive, and frequency generation circuitry including the digital receiver back-end IC and the reference oscillator.
- **Display/Keypad Assemblies** - contain the internal microphone and speaker, a two-line liquid crystal display (LCD), and a 3 x 6 keypad.
- **Control Top** - contains switches for volume and mode selection, push-to-talk (PTT), monitor, and several function-selectable switches.

C. Analog Mode of Operation

When the radio is *receiving*, the signal comes from the antenna/antenna-switch connector to the RF board, passes through the RX/TX switch and the receiver front end. The signal is then filtered, amplified, and mixed with the first local-oscillator signal generated by the voltage-controlled oscillator (VCO). The resulting intermediate frequency (IF) signal is fed to the IF circuitry, where it is again filtered and amplified. This amplified signal is passed to the digital back-end IC, where it is mixed with the second local oscillator to create the second IF at 450kHz. It is then converted to a digital bit stream and mixed a third time to produce a baseband signal. This signal is passed to the controller board through a current-driven differential output. On the controller board, the digital-signal-processor-support IC digitally filters and dis-

criminates the signal, and passes it to the digital-signal processor (DSP). The DSP decodes the information in the signal and identifies the appropriate destination for it. For a voice signal, the DSP will route the digital voice data to the DSP-support IC for conversion to an analog signal. The DSP-support IC will then present the signal to the audio power amplifier, which drives the speaker. For signalling information, the DSP will decode the message and pass it to the microcontrol unit.

When the radio is *transmitting*, microphone audio is passed from the audio power amplifier (PA) to the DSP-support IC, where the signal is digitized. The DSP-support IC passes digital data to the DSP, where pre-emphasis and low-pass (splatter) filtering are done. The DSP returns this signal to the DSP-support IC, where it is reconverted into an analog signal and scaled for application to the voltage-controlled oscillator as a modulation signal. Transmitted signalling information is accepted by the DSP from the microcontrol unit, coded appropriately, and passed to the DSP-support IC, which handles it the same as a voice signal. Modulation information is passed to the synthesizer along the modulation line. A modulated carrier is provided to the RF PA, which transmits the signal under dynamic power control.

D. ASTRO Mode of Operation

In the ASTRO mode (digital mode) of operation, the transmitted or received signal is limited to a discrete set of deviation levels, instead of continuously varying. The receiver handles an ASTRO-mode signal identically to an analog-mode signal up to the point where the DSP decodes the received data. In the ASTRO receive mode, the DSP uses a specifically defined algorithm to recover information. In the ASTRO transmit mode, microphone audio is processed identically to an analog mode with the exception of the algorithm the DSP uses to encode the information. This algorithm will result in deviation levels that are limited to discrete levels.

E. RF Board Basic Theory of Operation

The receiver front end consists of a preselector, an RF amplifier, a second preselector, and a mixer. Both preselectors in the VHF and UHF radios are varactor-tuned, two-pole filters controlled by the microcontrol unit through the digital/analog (D/A) IC. On the 800MHz receiver front end, these filters are fixed-tuned. The RF amplifier is a dual-gate, gallium-arsenide based IC. The mixer is a double-balanced,

active mixer coupled by transformers. Injection is provided by the VCO through an injection filter. See Table 14 for local oscillator (LO) and first IF information.

The frequency generation function is performed by three ICs and associated circuitry. The reference oscillator provides a frequency standard to the synthesizer/prescaler IC, which controls the VCO IC. The VCO IC actually generates the first LO and transmit-injection signals and buffers them to the required power level. The synthesizer/prescaler circuit module incorporates frequency-division and comparison circuitry to keep the VCO signals stable. The synthesizer/prescaler IC is controlled by the microcontrol unit through a serial bus. Most of the synthesizer circuitry is enclosed in rigid metal cans on the RF board to reduce microphonic effects.

The receiver back end consists of a two-pole crystal filter, an IF amplifier, a second two-pole crystal filter, and the digital back-end IC. The two-pole filters are wide enough to accommodate 5kHz modulation. Final IF filtering is done digitally in the DSP-support IC.

The digital back-end IC consists of an amplifier, the second mixer, an IF analog-to-digital converter, a baseband down-converter, and a 2.4MHz synthesis circuit to provide a clock to the DSP-support IC on the controller board. The second LO is generated by discrete components external to the IC. The output of the digital back-end IC is a digital bit stream that is current driven on a differential pair for a reduction in noise generation.

The transmitter consists of an RF PA IC that gets an injection signal from the VCO. Transmit power is controlled by two custom ICs that monitor the output of a directional coupler and adjust PA control voltages correspondingly. The signal passes through a RX/TX switch that uses PIN diodes to automatically provide an appropriate interface to transmit or receive signals. Antenna selection is done mechanically in the control top.

F. Controller Board Basic Theory of Operation

The controller board contains the radio's microcontrol unit with its memory and support circuits, voltage regulators, audio, DSP, and power control circuits. Connected to the controller board are the display board, RF board, and control top.

The microcontrol unit controls receive/transmit frequencies, power levels, display, and other radio functions, using either direct logic control or serial communications paths to the devices. The microcontrol unit executes a stored program located in the FLASH ROM. Data is transferred to and from memory by the microcontrol unit data bus. The memory location from which data is read, or to which data is written, is selected by the address lines.

The support-logic IC acts as an extension of the microcontrol unit by providing logic functions such as lower address latch, reset, memory address decoding, and additional control lines for the radio. The microcontrol unit controls the crystal-pull circuit to adjust the crystal oscillator's frequency on the microcontrol unit, so that the E-clock's harmonics do not cause interference with the radio's receive channel.

The regulator and power-control circuits include an unswitched +5V discrete circuit and the regulator/power-control IC. Switched +5V is used for all circuits on the controller board except the audio PA, which is sourced from 7.5V. The regulator automatically provides 5V when the radio is turned on. The regulator's power-down mode is controlled by the microcontrol unit, which senses the position of the on/off switch.

The DSP performs signalling and voice encoding and decoding as well as audio filtering and volume control. This IC performs Private-Line®/Digital Private Line™ (PL/DPL) encode and alert-tone generation. The IC transmits pre-emphasis on analog signals and applies a low-pass (splatter) filter to all transmitted signals. It requires a 33MHz crystal to function. An 8kHz interrupt signal generated by the DSP-support IC is also required for functionality. It is programmed using parallel programming from the microcontrol unit and the DSP-support IC.

The DSP-support IC performs analog-to-digital and digital-to-analog conversions on audio signals. It contains attenuators for volume, squelch, deviation, and compensation, and it executes receiver filtering and discrimination. The IC requires a 2.4MHz clock to function (generated by the digital back-end IC) and is programmed by the microcontrol unit SPI bus.

Table 14. Local Oscillator and First IF Frequencies

	VHF	UHF	800MHz
LO Frequency Range	181.15-223.15MHz	329.65-446.65MHz	732.65-796.65MHz
First IF Frequency	45.15MHz	73.35MHz	73.35MHz

SECTION VIII. BOARD-LEVEL TROUBLESHOOTING

A. Introduction to This Section

This section of the manual contains troubleshooting charts, error codes, a functional block diagram, interconnect diagrams, and flexible circuit information. This section will help you isolate a problem to the board level. Board-level troubleshooting does not attempt to isolate problems to the component level. Component-level service information can be found in the “ASTRO Digital SABER Portable Radios Detailed Service Manual.” (Refer to “Related Publications Available Separately” list located in the front section of this manual.)

NOTE

To access the various connector pins, use the housing eliminator/test fixture along with the diagrams found in this section of the manual. (Refer to the “Service Aids for Board-Level Troubleshooting” table for the appropriate Motorola housing eliminator/test fixture part number.)

B. Replacement Board Procedures

Once a problem has been narrowed down to a specific board, it is important to get the customer’s radio back in service as quickly as possible. This can be done several ways:

1. Install a good board from your inventory into the customer’s radio.

2. Order a replacement board from Worldwide System and Aftermarket Products Division at 1-800-422-4210.
3. Troubleshoot the defective board using the “ASTRO Digital SABER Portable Radios Detailed Service Manual.” (Refer to the “Related Publications Available Separately” list located in the front section of this manual for the specific manual number.)

C. Power-Up Error Codes

When the radio is turned on (power-up), the radio performs cursory tests to determine if its basic electronics and software are in working order. Problems detected during these tests are presented as error codes on the radio’s display. The presence of an error should prompt the user that a problem exists and that a service technician should be contacted.

Self-test errors are classified as either fatal or non-fatal. Fatal errors will inhibit user operation; non-fatal errors will not. Use Table 15 to aid in understanding particular power-up error code displays.

Table 15. Power-Up Error Code Displays

Error Code	Description	Corrective Action
01/81	ROM Checksum Failure	Reprogram the FLASH memory.
01/02	External EEprom Checksum Non-Fatal Error	Reprogram codeplug.
01/82	External EEprom Checksum Failure	Reprogram the codeplug.
01/88	RAM Failure - Note: not a checksum failure	Turn the radio off, then on.
01/90	General Hardware Failure	Turn the radio off, then on.
01/92	Internal EEPROM Checksum Failure	Reprogram the codeplug.
02/10	DSP support IC checksum Non-Fatal Error	Turn the radio off, then on.
02/81	DSP ROM Checksum Failure	Reprogram the FLASH memory.
02/88	DSP RAM Failure - Note: not a checksum failure	Turn the radio off, then on.
02/90	General DSP Hardware Failure (DSP startup message not received correctly)	Turn the radio off, then on.

Note: If the corrective action does not fix the failure, replace the controller board.

D. Operational Error Codes

During radio operation, the radio performs dynamic tests to determine if the radio is working properly. Problems detected during these tests are presented as error codes on the radio's display. The presence of

an error code should prompt a user that a problem exists and that a service technician should be contacted. Use Table 16 to aid in understanding particular operational error codes.

Table 16. Operational Error Code Displays

Error Code	Description	Corrective Action
FAIL 001	Synthesizer Out-of-Lock	a. Reprogram codeplug b. Replace RF Board
FAIL 002	Selected Mode/Zone Codeplug Checksum Error	Reprogram codeplug

Table 17. Receiver Troubleshooting Chart

Symptom	Possible Cause	Correction or Test (Measurements Taken at Room Temperature)
Radio Dead; Display Does Not Light Up	1. Dead Battery	Replace with charged battery.
	2. Blown Fuse	Check see-through fuse on RF board near the B+ connector.
	3. On/Off Switch	With the radio on, check for B+ SENSE at P901 pin 10 of the control top/PTT flex; if not there, check for UNSW B+ at pin 19 of RF board connector; if not there, replace the RF board; if there, replace the controller board.
	4. Regulators	Check for +5V at P901 pin 5 of the control top/PTT flex; if not there, replace the controller board.
Radio Dead; Display Lights Up	1. Controller Board	Check board for communication with RSS. If no communication, replace controller board.
	2. RF Board	Check the ODC (output data clock) at pin 8 of the RF board connector for 2.4MHz. If not there, replace RF board.
No Receiver Audio or Receiver Does Not Unmute	1. Programming	a. Does the transmitted signal match the receiver configuration (PL, DPL, etc.)? b. With the monitor function enabled, can the radio be unmuted?
Audio Distorted or Not Loud Enough	1. Synthesizer Not On Frequency	Check synthesizer frequency by measuring the transmitter frequency; if off by more than $\pm 250\text{Hz}$, realign.
RF Sensitivity Poor	1. Synthesizer Not On Frequency	Check synthesizer frequency by measuring the transmitter frequency; if off by more than $\leq \pm 600\text{Hz}$, realign.
	2. Antenna Switch	Visually check for proper mechanical positioning of the antenna switch to the RF board; re-position if necessary. Then, check for electrical continuity between the center pin of the antenna connector and the RF board; replace defective item.
	3. Receiver Front-End Tuning (VHF/UHF only)	Check RF front-end tuning for optimum sensitivity using the RSS.
Radio Will Not Turn Off	1. Controller Board	Does B+ SENSE at P901 pin 10 of the control top/PTT flex switch on and off as the on/off switch is operated? If not, replace the controller board.

Table 18. Transmitter Troubleshooting Chart

Symptom	Possible Cause	Correction or Test (Measurements Taken at Room Temperature)
No RF Power Out	1. TX Power Level or Frequency	Check TX power level and frequency programming (from RSS).
	2. No PTT From Control Top	With the PTT switch depressed (radio transmitting/keyed), check for INT PTT at P901 pin 6 of the control top/PTT flex; if not there, replace the control top/PTT flex.
	3. No Injection To Power Amplifier	Check LOCK DETECT at pin 13 of the RF board connector; if not between 1.0 and 4.5V, replace the RF board.
No Modulation; Distorted Modulation	1. Programming	Check deviation and compensation settings using the RSS.
	2. Controller Board	With a 1kHz tone at 80mVrms injected at the external microphone, is the output of the controller board to RF board connector pin 15 distorted? If so, replace the controller board.
Bad Microphone Sensitivity	1. Check Deviation and Compensation	Realign if necessary.
	2. Microphone	Speaking loudly into the microphone, monitor the output voltage (INT MIC) at the speaker microphone flex connector, P701 pin 4. If not 2mVrms, replace the speaker/microphone and front shield assembly.
No/Low Signalling (PL, DPL, MDC)	1. Check Programming	
	2. Controller Board	Check for proper modulation at the RF board to controller board connector pin 15; if not there, replace the controller board.
Can't Set Compensation	1. RF Board	If maximum deviation can be set to > 5.0kHz, but compensation cannot be set, replace the RF board.

