

ASTRO® Digital Spectra®
and Digital Spectra Plus
VHF
UHF
800 MHz
Mobile Radios



MOTOROLA
intelligence everywhere™

Detailed Service Manual





**ASTRO® Digital Spectra®
and Digital Spectra Plus
VHF/UHF/800 MHz Mobile Radios
Detailed Service Manual**

Foreword

This manual provides sufficient information to enable qualified service technicians to troubleshoot and repair ASTRO® Digital Spectra® and ASTRO Digital Spectra Plus mobile radios (models W3, W4, W5, W7, and W9) to the component level. For the most part, the information in this manual pertains to both ASTRO Digital Spectra and ASTRO Digital Spectra Plus radios. Exceptions are clearly noted where they occur.

For details on radio operation or basic troubleshooting, refer to the applicable manuals available separately. A list of related publications is provided in the section, "Related Publications," on page xv.

Product Safety and RF Exposure Compliance

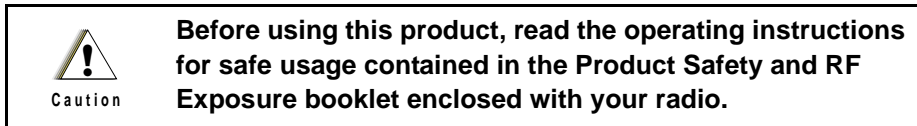

ATTENTION!

This radio is restricted to occupational use only to satisfy FCC RF energy exposure requirements. Before using this product, read the RF energy awareness information and operating instructions in the Product Safety and RF Exposure booklet enclosed with your radio (Motorola Publication part number 6881095C99) to ensure compliance with RF energy exposure limits.

For a list of Motorola-approved antennas, batteries, and other accessories, visit the following web site which lists approved accessories: <http://www.motorola.com/cgiss/index.shtml>.

Manual Revisions

Changes which occur after this manual is printed are described in FMRs (Florida Manual Revisions). These FMRs provide complete replacement pages for all added, changed, and deleted items, including pertinent parts list data, schematics, and component layout diagrams. To obtain FMRs, contact the Customer Care and Services Division (refer to "Appendix B Replacement Parts Ordering").

Computer Software Copyrights

The Motorola products described in this manual may include copyrighted Motorola computer programs stored in semiconductor memories or other media. Laws in the United States and other countries preserve for Motorola certain exclusive rights for copyrighted computer programs, including, but not limited to, the exclusive right to copy or reproduce in any form the copyrighted computer program. Accordingly, any copyrighted Motorola computer programs contained in the Motorola products described in this manual may not be copied, reproduced, modified, reverse-engineered, or distributed in any manner without the express written permission of Motorola. Furthermore, the purchase of Motorola products shall not be deemed to grant either directly or by implication, estoppel, or otherwise, any license under the copyrights, patents or patent applications of Motorola, except for the normal non-exclusive license to use that arises by operation of law in the sale of a product.

Document Copyrights

No duplication or distribution of this document or any portion thereof shall take place without the express written permission of Motorola. No part of this manual may be reproduced, distributed, or transmitted in any form or by any means, electronic or mechanical, for any purpose without the express written permission of Motorola.

Disclaimer

The information in this document is carefully examined, and is believed to be entirely reliable. However, no responsibility is assumed for inaccuracies. Furthermore, Motorola reserves the right to make changes to any products herein to improve readability, function, or design. Motorola does not assume any liability arising out of the applications or use of any product or circuit described herein; nor does it cover any license under its patent rights nor the rights of others.

Trademarks

MOTOROLA, the Stylized M logo, ASTRO, and Spectra are registered in the US Patent & Trademark Office. All other product or service names are the property of their respective owners.

Table of Contents

Foreword	ii
Product Safety and RF Exposure Compliance	ii
Manual Revisions	ii
Computer Software Copyrights	ii
Document Copyrights	ii
Disclaimer	ii
Trademarks	ii
Related Publications	xv
Commercial Warranty	xvii
Limited Warranty	xvii
MOTOROLA COMMUNICATION PRODUCTS	xvii
I. What This Warranty Covers And For How Long	xvii
II. General Provisions	xvii
III. State Law Rights	xviii
IV. How To Get Warranty Service	xviii
V. What This Warranty Does Not Cover	xviii
VI. Patent And Software Provisions	xix
VII. Governing Law	xix
Model Numbering, Charts, and Specifications	xxi
Mobile Radio Model Numbering Scheme	xxi
ASTRO Digital Spectra Motorcycle 15 Watt (Ranges 1 and 2) Model Chart	xxii
ASTRO Digital Spectra Motorcycle 15 Watt (Ranges 3 and 3.5) Model Chart	xxiii
ASTRO Digital Spectra VHF 10–25 Watt Model Chart	xxiv
ASTRO Digital Spectra VHF 25–50 and 50–110 Watt Model Chart	xxv
ASTRO Digital Spectra UHF 10–25 Watt Model Chart	xxvii
ASTRO Digital Spectra UHF 20–40 Watt Model Chart	xxviii
ASTRO Digital Spectra UHF 50–110 Watt Model Chart	xxx
ASTRO Digital Spectra 800 MHz Model Chart	xxxii
ASTRO Digital Spectra Plus VHF 25–50 and 50–110 Watt Model Chart	xxxiii
ASTRO Digital Spectra Plus UHF 20–40 Watt Model Chart	xxxv
ASTRO Digital Spectra Plus UHF 50–110 Watt Model Chart	xxxvii
ASTRO Digital Spectra Plus 800 MHz Model Chart	xxxix
VHF Radio Specifications	xli
UHF Radio Specifications	xlii
800 MHz Radio Specifications	xliii
Chapter 1 Introduction	1-1
1.1 General	1-1
1.2 Notations Used in This Manual	1-2

Chapter 2	General Overview	2-1
2.1	Introduction.....	2-1
2.2	Analog Mode of Operation	2-2
2.3	ASTRO Mode of Operation	2-2
2.4	Control Head Assembly.....	2-2
2.4.1	Display (W3 Model)	2-2
2.4.2	Display (W4, W5, and W7 Models)	2-2
2.4.3	Display (W9 Model)	2-3
2.4.4	Vacuum Fluorescent Display Driver	2-3
2.4.5	Vacuum Fluorescent Voltage Source (W9 Model)	2-3
2.4.6	Controls and Indicators	2-3
2.4.7	Status LEDs	2-3
2.4.8	Backlight LEDs	2-3
2.4.9	Vehicle Interface Ports	2-4
2.4.10	Power Supplies	2-4
2.4.11	Ignition Sense Circuits.....	2-4
2.5	Power Amplifier	2-5
2.5.1	Gain Stages.....	2-5
2.5.2	Power Control.....	2-5
2.5.3	Circuit Protection	2-5
2.5.4	DC Interconnect	2-5
2.6	Front-End Receiver Assembly.....	2-6
2.7	RF Board Basic	2-6
2.8	Voltage-Controlled Oscillator.....	2-6
2.8.1	VHF Radios	2-6
2.8.2	UHF and 800 MHz Radios	2-7
2.9	Command Board	2-7
2.10	ASTRO Spectra Vocoder/Controller Board	2-7
2.11	Radio Power	2-8
2.11.1	General.....	2-8
2.11.2	B+ Routing for ASTRO Spectra VOCON Board.....	2-9
Chapter 3	Theory of Operation	3-1
3.1	RF Board.....	3-1
3.1.1	General.....	3-1
3.1.2	Synthesizer.....	3-3
3.1.2.1	Reference Frequency Generation	3-3
3.1.2.2	First VCO Frequency Generation	3-3
3.1.2.3	Programmable Reference Divider	3-4
3.1.2.4	Phase Modulator	3-5
3.1.2.5	Loop Filter	3-5
3.1.2.6	Auxiliary Control Bits	3-5
3.1.2.7	Second VCO	3-6
3.1.2.8	Power Distribution	3-6
3.1.3	Receiver Back-End.....	3-6
3.1.3.1	First IF	3-6
3.1.3.2	ABACUS II IC	3-7
3.2	Command Board	3-8
3.2.1	Microcontroller and Support ICs	3-8
3.2.2	Serial Input/Output IC.....	3-8
3.2.3	Power-Up/-Down Sequence.....	3-9

3.2.4	Regulators	3-10
3.2.5	Reset Circuits	3-10
3.2.6	Serial Communications on the External Bus	3-11
3.2.7	Synchronous Serial Bus (MOSI)	3-12
3.2.8	Received Audio	3-12
3.2.9	Microphone Audio	3-12
3.2.10	Transmit Deviation	3-13
3.2.11	RS-232 Line Driver	3-13
3.2.12	Flash Programming	3-13
3.2.13	Encryption Voltages	3-13
3.2.14	Regulator and Power-Control IC	3-14
3.3	ASTRO Spectra VOCON Board	3-15
3.3.1	General.....	3-15
3.3.2	Controller Section	3-15
3.3.3	Vocoder Section	3-17
3.3.4	RX Signal Path	3-18
3.3.5	TX Signal Path	3-21
3.3.6	Controller Bootstrap and Asynchronous Buses.....	3-22
3.3.7	Vocoder Bootstrap.....	3-24
3.3.8	Serial Peripheral Interface (SPI) Bus	3-24
3.3.9	Controller Memory Map.....	3-24
3.3.10	Vocoder Memory Map	3-26
3.3.11	MCU System Clock	3-28
3.3.12	DSP System Clock	3-28
3.3.13	Radio Power-Up/Power-Down Sequence	3-28
3.3.14	VOCON Board Signals.....	3-29
3.4	ASTRO Spectra Plus VOCON Board	3-38
3.4.1	General.....	3-38
3.4.2	ASTRO Spectra Plus Controller Section	3-38
3.4.3	ASTRO Spectra Plus Vocoder Section	3-39
3.4.4	ASTRO Spectra Plus RX Signal Path	3-41
3.4.5	ASTRO Spectra Plus TX Signal Path.....	3-42
3.4.6	ASTRO Spectra Plus Controller Bootstrap and Asynchronous Busses	3-43
3.4.7	ASTRO Spectra Plus Serial Peripheral Interface Bus.....	3-44
3.4.8	ASTRO Spectra Plus MCU and DSP System Clocks	3-44
3.4.9	ASTRO Spectra Plus Voltage Regulators	3-45
3.4.10	ASTRO Spectra Plus Radio Power-Up/Power-Down Sequence	3-46
3.5	Voltage Control Oscillator.....	3-47
3.5.1	VHF Band.....	3-47
3.5.1.1	General.....	3-47
3.5.1.2	DC Voltage Supplies	3-47
3.5.1.3	VCO.....	3-47
3.5.1.4	Synthesizer Feedback.....	3-48
3.5.1.5	RX Buffer Circuitry.....	3-48
3.5.1.6	Frequency Divider and TX Buffer Circuitry.....	3-48
3.5.2	UHF Band.....	3-48
3.5.2.1	General.....	3-48
3.5.2.2	Super Filter 8.6 V	3-49
3.5.2.3	VCO.....	3-49
3.5.2.4	Receive Mode (AUX2* Low).....	3-49
3.5.2.5	Transmit Mode (AUX2* High).....	3-49
3.5.2.6	Bandshift Circuit	3-49
3.5.2.7	Output Buffer	3-49
3.5.2.8	First Buffer	3-49

3.5.2.9	Doubler.....	3-50
3.5.2.10	Synthesizer Feedback.....	3-50
3.5.2.11	Second Buffer.....	3-50
3.5.2.12	Receive/Transmit Switch.....	3-50
3.5.3	800 MHz Band.....	3-50
3.5.3.1	General.....	3-50
3.5.3.2	Super Filter 8.6 V	3-50
3.5.3.3	VCO.....	3-50
3.5.3.4	Receive Mode-AUX 1* and AUX 2* High	3-51
3.5.3.5	Transmit Mode-AUX 1* High; AUX 2* Low.....	3-51
3.5.3.6	TalkAround Mode-AUX 1* Low; AUX 2* Low	3-51
3.5.3.7	VCO Buffer.....	3-51
3.5.3.8	First Buffer Circuit.....	3-51
3.5.3.9	Doubler.....	3-51
3.5.3.10	Second Buffer.....	3-52
3.5.3.11	K9.4 V Switch.....	3-52
3.6	Receiver Front-End	3-53
3.6.1	VHF Band.....	3-53
3.6.1.1	General.....	3-53
3.6.1.2	Theory of Operation	3-53
3.6.2	UHF Band.....	3-53
3.6.2.1	General.....	3-53
3.6.2.2	Theory of Operation	3-54
3.6.3	800 MHz Band.....	3-54
3.6.3.1	General.....	3-54
3.6.3.2	Theory of Operation	3-54
3.7	Power Amplifiers	3-55
3.7.1	VHF Band Power Amplifiers.....	3-55
3.7.1.1	High-Power Amplifier.....	3-55
3.7.1.1.1	Transmitter	3-55
3.7.1.1.2	Antenna Switch and Harmonic Filter	3-56
3.7.1.1.3	Power Control Circuitry	3-57
3.7.1.2	25/10-Watt Power Amplifier.....	3-59
3.7.1.2.1	Antenna Switch and Harmonic Filter	3-60
3.7.1.2.2	Power Control Circuitry	3-60
3.7.1.3	50-Watt Power Amplifiers.....	3-63
3.7.1.3.1	Transmitter	3-63
3.7.1.3.2	Antenna Switch and Harmonic Filter	3-64
3.7.1.3.3	Power Control Circuitry	3-65
3.7.2	UHF Band Power Amplifiers.....	3-68
3.7.2.1	High-Power Amplifier.....	3-68
3.7.2.1.1	Transmitter	3-68
3.7.2.1.2	Antenna Switch and Harmonic Filter	3-69
3.7.2.1.3	Power Control Circuitry	3-69
3.7.2.2	40-Watt Power Amplifier.....	3-72
3.7.2.2.1	Transmitter	3-72
3.7.2.2.2	Antenna Switch and Harmonic Filter	3-73
3.7.2.2.3	Power Control Circuitry	3-74
3.7.3	800 MHz Band Power Amplifiers.....	3-77
3.7.3.1	15- and 35-Watt Amplifiers.....	3-77
3.7.3.1.1	Transmitter	3-77
3.7.3.1.2	Antenna Switch and Harmonic Filter	3-78
3.7.3.1.3	Power Control Circuitry	3-79
3.7.3.1.4	Temperature Sensing.....	3-81

Chapter 4	Troubleshooting Procedures	4-1
4.1	ASTRO Spectra Procedures	4-1
4.1.1	Handling Precautions	4-1
4.1.2	Voltage Measurement and Signal Tracing	4-2
4.1.3	Power-Up Self-Check Errors	4-2
4.1.3.1	Power-Up Sequence	4-3
4.1.4	RF Board Troubleshooting	4-5
4.1.4.1	Display Flashes "FAIL 001"	4-5
4.1.4.1.1	Incorrect Values at U602, Pin 19	4-6
4.1.4.1.2	Incorrect Values at U602 Pin 25 (MODULUS CONTROL)	4-7
4.1.4.1.3	Incorrect Voltage at Positive Steering Line	4-7
4.1.4.1.4	Incorrect Values at U602, pin 27	4-7
4.1.4.2	Review of Synthesizer Fundamentals	4-7
4.1.4.3	Second VCO Checks	4-8
4.1.4.4	Troubleshooting the Back-End	4-8
4.1.5	Standard Bias Table	4-9
4.2	ASTRO Spectra Plus Procedures	4-10
4.2.1	ASTRO Spectra Plus Power-Up Self-Check Errors	4-10
4.2.2	ASTRO Spectra Plus Power-Up Self-Check Diagnostics and Repair	4-11
4.2.3	ASTRO Spectra Plus Standard Bias Table	4-12
4.3	VCO Procedures	4-13
4.3.1	VHF Band	4-13
4.3.1.1	VCO Hybrid Assembly	4-13
4.3.1.2	Out-of-Lock Condition	4-13
4.3.1.3	No or Low Output Power (TX or RX Injection)	4-15
4.3.1.4	No or Low Modulation	4-15
4.3.2	UHF Band	4-15
4.3.2.1	VCO Hybrid Assembly	4-15
4.3.2.2	Out-of-Lock Condition	4-16
4.3.2.3	No or Low Output Power (TX or RX Injection)	4-16
4.3.2.4	No or Low Modulation	4-17
4.3.3	800 MHz Band	4-18
4.3.3.1	VCO Hybrid Assembly	4-18
4.3.3.2	Out-of-Lock Condition	4-18
4.3.3.3	No or Low Output Power (TX or RX Injection)	4-19
4.3.3.4	No or Low Modulation	4-19
4.4	Receiver Front-End (RXFE)	4-20
4.4.1	VHF Band	4-20
4.4.2	UHF Band	4-20
4.4.3	800 MHz Band	4-20
4.5	Power Amplifier Procedures	4-21
4.5.1	VHF Band	4-21
4.5.1.1	High-Power Amplifier	4-21
4.5.1.1.1	General Troubleshooting and Repair Notes	4-21
4.5.1.1.2	PA Functional Testing	4-25
4.5.1.1.3	Power Control and Protection Circuitry	4-28
4.5.1.2	25/10 Watt Power Amplifier	4-29
4.5.1.2.1	General Troubleshooting and Repair Notes	4-29
4.5.1.2.2	PA Functional Testing	4-30
4.5.1.2.3	Localizing Problems	4-34
4.5.1.2.4	Isolating Failures	4-35
4.5.1.2.5	Power Control and Protection Circuitry	4-37
4.5.1.3	50 Watt Power Amplifiers	4-38

4.5.1.3.1	General Troubleshooting and Repair Notes	4-38
4.5.1.3.2	PA Functional Testing	4-39
4.5.1.3.3	Localizing Problems	4-42
4.5.1.3.4	Isolating Failures	4-43
4.5.1.3.5	Power Control and Protection Circuitry	4-45
4.5.2	UHF Band.....	4-47
4.5.2.1	High-Power Amplifier.....	4-47
4.5.2.1.1	General Troubleshooting and Repair Notes.....	4-47
4.5.2.1.2	PA Functional Testing	4-51
4.5.2.1.3	Power Control and Protection Circuitry	4-54
4.5.2.2	40 Watt Power Amplifiers	4-56
4.5.2.2.1	General Troubleshooting and Repair Notes.....	4-56
4.5.2.2.2	PA Functional Testing	4-57
4.5.2.2.3	Localizing Problems	4-61
4.5.2.2.4	Isolating Failures	4-62
4.5.2.2.5	Power Control and Protection Circuitry	4-64
4.5.3	800 MHz Band.....	4-66
4.5.3.1	15 Watt and 35 Watt Power Amplifiers.....	4-66
4.5.3.1.1	General Troubleshooting and Repair Notes.....	4-66
4.5.3.1.2	PA Functional Testing	4-67
4.5.3.1.3	Localizing Problems	4-71
4.5.3.1.4	Isolating Failures	4-72
4.5.3.1.5	Power Control and Protection Circuitry	4-74

Chapter 5 Troubleshooting Charts 5-1

5.1	Introduction.....	5-1
5.2	List of Troubleshooting Charts	5-1
	RF Board Back-End.....	5-3
	Command Board.....	5-4
	Radio Power-Up Fail.....	5-5
	Bootstrap Fail.....	5-6
	01/90, General Hardware Failure	5-7
	01/81, Host ROM Checksum Failure	5-7
	01/82 or 002, External EEPROM Checksum Failure	5-8
	01/84, SLIC Initialization Failure	5-8
	01/88, MCU (Host mC) External SRAM Failure.....	5-9
	01/92, Internal EEPROM Checksum Failure	5-9
	02/A0, ADSIC Checksum Failure.....	5-10
	02/81, DSP ROM Checksum Failure	5-10
	02/88, DSP External SRAM Failure U414	5-11
	02/84, DSP External SRAM Failure U403	5-11
	02/82, DSP External SRAM Failure U402	5-12
	02/90, General DSP Hardware Failure	5-12
	09/10, Secure Hardware Failure	5-13
	09/90, Secure Hardware Failure	5-13
	No RX Audio	5-14
	No TX Modulation	5-15
	Key Load Fail.....	5-16
	800 MHz Receiver Front-End Hybrid	5-17
	UHF Receiver Front-End Hybrid	5-17
	VHF Receiver Front-End Hybrid	5-18
	ASTRO Spectra Plus VOCON Power-Up Failure	5-19

ASTRO Spectra Plus VOCON DC Supply Failure5-20
 ASTRO Spectra Plus VOCON TX Modulation Failure Sheet 1 of 45-21
 ASTRO Spectra Plus VOCON TX Modulation Failure Sheet 2 of 45-22
 ASTRO Spectra Plus VOCON TX Modulation Failure Sheet 3 of 45-23
 ASTRO Spectra Plus VOCON TX Modulation Failure Sheet 4 of 45-24
 ASTRO Spectra Plus VOCON RX Audio Failure5-24
 ASTRO Spectra Plus VOCON Secure Hardware Failure5-25
 ASTRO Spectra Plus VOCON Key Load Fail5-26

Chapter 6 Troubleshooting Waveforms6-1

6.1 Introduction.....6-1
 6.2 ASTRO Digital Spectra Waveforms6-2
 Waveform W1: Power-On Reset Timing6-2
 Waveform W2: DSP SSI Port RX Mode.....6-2
 Waveform W3: DSP SSI Port TX Mode CSQ6-3
 Waveform W4: ABACUS Programming at Mode Change.....6-3
 Waveform W5: ABACUS/ADSIC Interface.....6-4
 Waveform W6: SPI Bus Programming ADSIC6-4
 Waveform W7: Receive Audio6-5
 Waveform W8: Transmit Audio6-5
 Waveform W9: Power-Down Reset.....6-6
 Waveform W10: ADSIC 2.4 MHz Reference.....6-6
 6.3 ASTRO Digital Spectra Plus VOCON Board Waveforms.....6-7
 32 kHz Clock Waveform.....6-7
 16.8 MHz Clock Waveform.....6-8
 TX Modulation Out Waveform6-8
 Differential ADDAG Output Waveform6-9
 TX SSI Waveform.....6-9
 SPI Bus Waveform6-10
 TX 1 kHz Tone Waveform6-10
 Serial Audio Port Waveform6-11
 RX Audio Waveform.....6-11
 RX BBP Waveform.....6-12
 Secure Interface Waveform.....6-12
 8 kHz Frame Sync for Security Circuitry Waveform6-13

Chapter 7 Schematics, Component Location Diagrams and Parts Lists7-1

7.1 List of Schematics and Component Location Diagrams.....7-1
 7.2 RF Section7-2
 ASTRO Spectra Radio Interconnection7-4
 HRN4009B/HRN6014A VHF RF Board, HRN4010B/HRN6020A UHF RF Board, and
 HRN6019A 800 MHz RF Board Schematic7-5
 HRN4009B/HRN6014A VHF RF Board, HRN4010B/HRN6020A UHF RF Board, and
 HRN6019A 800 MHz RF Board Component Location Diagrams7-6
 HRN4009C/HRN6014C VHF RF Board Schematic Diagram7-9
 HRN4009C/HRN6014C VHF RF Board Component Location Diagrams7-10
 HRN4009E/HRN6014D VHF RF Board, HRN4010D/HRN6020C UHF RF Board, and
 HRN6019C 800 MHz RF Board Schematic Diagram (Sheet 1 of 2).....7-12
 HRN4009E/HRN6014D VHF RF Board, HRN4010D/HRN6020C UHF RF Board, and

	HRN6019C 800 MHz RF Board Schematic Diagram (Sheet 2 of 2).....	7-13
	HRN4009E/HRN6014D VHF RF Board, HRN4010D/HRN6020C UHF RF Board, and HRN6019C 800 MHz RF Component Location Diagram.....	7-14
7.3	Command Board Section	7-17
	HLN5558E/F/G, HLN6529C/D/E/F/G, HLN6560C/D/E/F/G/H, and HLN6562C/D/E/F/G/H Command Board Schematic Diagram	7-17
	HLN5558E/F/G, HLN6529C/D/E, HLN6560C/D/E/F/G/H, and HLN6562C/D/E/F/G/H Command Board Component Location Diagrams	7-18
	HLN5558H/J, HLN6529H, HLN6560J, and HLN6562J Command Board Schematic Diagram	7-21
	HLN5558H/J, HLN6529H, HLN6560J, and HLN6562J Component Location Diagram.....	7-22
7.4	VOCON Section	7-26
	HLN6458D VOCON Board Schematic (Sheet 1 of 2).....	7-26
	HLN6458D VOCON Board Schematic (Sheet 2 of 2).....	7-27
	HLN6458D VOCON Board Component Location Diagrams (Sheet 1 of 2).....	7-28
	HLN6458D VOCON Board Component Location Diagrams (Sheet 2 of 2).....	7-29
	HLN6458E VOCON Board Schematic (Sheet 1 of 2).....	7-32
	HLN6458E VOCON Board Schematic (Sheet 2 of 2).....	7-33
	HLN6458E VOCON Board Component Location Diagrams (Sheet 1 of 2).....	7-34
	HLN6458E VOCON Board Component Location Diagrams (Sheet 2 of 2).....	7-35
	HLN6458F/G VOCON Board Schematic (Sheet 1 of 2).....	7-38
	HLN6458F/G VOCON Board Schematic (Sheet 2 of 2).....	7-39
	HLN6458F/G VOCON Board Component Location Diagrams (Sheet 1 of 2).....	7-40
	HLN6458F/G VOCON Board Component Location Diagrams (Sheet 2 of 2).....	7-41
	HLN6458H VOCON Board Schematic (Sheet 1 of 2).....	7-44
	HLN6458H VOCON Board Schematic (Sheet 2 of 2).....	7-45
	HLN6458H VOCON Board Component Location Diagrams.....	7-46
7.5	ASTRO Spectra Plus VOCON Section	7-49
	ASTRO Spectra Plus VOCON Top Level Schematic (Sheet 1 of 2).....	7-49
	ASTRO Spectra Plus VOCON Top Level Schematic (Sheet 2 of 2).....	7-50
	HLN6837A ASTRO Spectra Plus RF Interface Schematic (Sheet 1 of 2).....	7-51
	HLN6837A ASTRO Spectra Plus RF Interface Schematic (Sheet 2 of 2).....	7-52
	HLN6837A ASTRO Spectra Plus Digital/USB Schematic (Sheet 1 of 2).....	7-53
	HLN6837A ASTRO Spectra Plus Digital/USB Schematic (Sheet 2 of 2).....	7-54
	HLN6837A ASTRO Spectra Plus Audio/DC Schematic	7-55
	HLN6837A ASTRO Spectra Plus Voltage Conversion Schematic.....	7-56
	HLN6837A ASTRO Spectra Plus Secure Interface Schematic	7-57
	HLN6837A ASTRO Spectra Plus VOCON Component Location Diagram, Top View	7-58
	HLN6837A ASTRO Spectra Plus VOCON Component Location Diagram, Bottom View	7-59
	HLN6837C ASTRO Spectra Plus VOCON Top Level Schematic (Sheet 1 of 2).....	7-62
	HLN6837C ASTRO Spectra Plus VOCON Top Level Schematic (Sheet 2 of 2).....	7-63
	HLN6837C ASTRO Spectra Plus Digital/Memory Schematic (Sheet 1 of 2).....	7-64
	HLN6837C ASTRO Spectra Plus Digital/Memory Schematic (Sheet 2 of 2).....	7-65
	HLN6837C ASTRO Spectra Plus Audio/DC Discrete Schematic	7-66
	HLN6837C ASTRO Spectra Plus RF Interface Schematic.....	7-67
	HLN6837C ASTRO Spectra Plus Secure Schematic	7-68
	HLN6837C ASTRO Spectra Plus VTrans/USB Schematic.....	7-69
	HLN6837C ASTRO Spectra Plus VOCON Component Location Diagram, Top View	7-70
	HLN6837C ASTRO Spectra Plus VOCON Component Location Diagram, Bottom View	7-71
7.6	VCO Section.....	7-75
	HLD6061D and HLD6062D VHF VCO Hybrid Schematic	7-75
	HLD6061D and HLD6062D VHF VCO Hybrid Component Location Diagram	7-76
	HLD4342B and HLD4343B VHF VCO Carrier Schematic Diagram	7-78
	HLD4342D and HLD4343D VHF VCO Carrier Schematic Diagram.....	7-79

	HLD4342B/HLD4343B VHF VCO Carrier Component Location Diagram	7-80
	HLD4342D/HLD4343D VHF VCO Carrier Component Location Diagram.....	7-81
	UHF VCO Ranges 1, 2, 3, and 4 Hybrid Schematic	7-84
	HLE6101A UHF VCO Range 1 Hybrid and HLE6102A Range 2 Hybrid Component Location Diagram	7-85
	HLE6103B UHF VCO Range 3 Hybrid and HLE6104B Range 4 Hybrid Component Location Diagram	7-87
	UHF VCO Ranges 1, 2, 3, and 4 Schematic Diagram	7-89
	HLE6045B Range 1 and HLE6046B Range 2 UHF VCO Component Location Diagram	7-90
	HLE6000D Range 3 and HLE6041D Range 4 UHF VCO Component Location Diagrams...	7-91
	HLF6080B 800 MHz VCO Schematic Diagram	7-93
	HLF6080B 800 MHz VCO Component Location Diagram.....	7-94
7.7	RX Front-End Section	7-96
	HRD6001E/6002E/6011E/6012E VHF Receiver Front-End Schematic.....	7-96
	HRD6001E/6002E/6011E/6012E VHF Component Location Diagram.....	7-97
	HRD6001G/6002G/6011G/6012G VHF Receiver Front-End Schematic.....	7-101
	HRD6001G/6002G/6011G/6012G VHF Receiver Front-End Component Location Diagram	7-102
	HRE6001B/6002C/6003B/6004B/6011B/6012B/6014B UHF Receiver Front-End Preamp and Standard Schematics	7-104
	HRE6001B/6002C/6003B/6004B/6011B/6012B/6014B UHF Receiver Front-End Hybrid Component Location Diagram	7-105
	HRF6004B/C 800 MHz Receiver Front-End Schematic Diagram.....	7-108
	HRF6004B/C 800 MHz Receiver Front-End Component Location Diagram	7-109
7.8	Power Amplifier Section	7-111
	HLD6022C VHF 50 Watt PA Schematic	7-111
	HLD6022C VHF 50-Watt PA Component Location Diagram, Side 1	7-112
	HLD6022C VHF 50-Watt PA Component Location Diagram, Side 2.....	7-113
	HLD6064C VHF Range 1 and HLD6063D Range 2 100-Watt PA Schematic.....	7-115
	HLD6064C VHF Range 1 and HLD6063D Range 2 100-Watt PA Component Location Diagram, Side 1	7-116
	HLD6064C VHF Range 1 and HLD6063D Range 2 100-Watt PA Component Location Diagram, Side 2	7-117
	HLD6032B/HLD6066B VHF 25-Watt PA Schematic	7-119
	HLD6032B/HLD6066B VHF 25-Watt PA Component Location Diagram, Side 1.....	7-120
	HLD6032B/HLD6066B VHF 25-Watt PA Component Location Diagram, Side 2	7-121
	HLE6062B and HLE6071B UHF 25-Watt PA Schematic.....	7-124
	HLE6062B UHF 25-Watt PA Component Location Diagram, Side 1	7-125
	HLE6062B UHF 25-Watt PA Component Location Diagram, Side 2	7-126
	HLE6043C, HLE6044C, and HLE6049B UHF 40-Watt PA Schematic	7-128
	HLE6043C, HLE6044C, and HLE6049B UHF 40-Watt PA Component Location Diagram, Side 1	7-129
	HLE6043C, HLE6044C, and HLE6049B UHF 40-Watt PA Component Location Diagram, Side 2	7-130
	HLE6039C, HLE6040C, and HLE6051C UHF 100-Watt PA Schematic	7-134
	HLE6039C, HLE6040C, and HLE6051C UHF 100-Watt PA Component Location Diagram, Side 1	7-135
	HLE6039C, HLE6040C, and HLE6051C UHF 100-Watt PA Component Location Diagram, Side 2	7-136
	HLF6078B 800 MHz 15-Watt PA Schematic	7-141
	HLF6078B 800 MHz 15-Watt PA Component Location Diagram, Side 1	7-142
	HLF6078B 800 MHz 15-Watt PA Component Location Diagram, Side 2.....	7-143
	HLF6077D 800 MHz 35-Watt PA Schematic.....	7-145
	HLF6077D 800 MHz 35-Watt PA Component Location Diagram, Side 1	7-146

HLF6077D 800 MHz 35-Watt PA Component Location Diagram, Side 2.....7-147

Appendix A Secure Modules A-1

- A.1 Introduction..... A-1
- A.2 Circuit Description A-2
- A.3 Troubleshooting Secure Operations..... A-2
 - A.3.1 Error 09/10, Error 09/90 A-2
 - A.3.2 Keyload A-2

Appendix B Replacement Parts Ordering B-1

- B.1 Basic Ordering Information..... B-1
- B.2 Transceiver Board and VOCON Board Ordering Information B-1
- B.3 Motorola Online B-1
- B.4 Mail Orders..... B-1
- B.5 Telephone Orders B-2
- B.6 Fax Orders B-2
- B.7 Parts Identification..... B-2
- B.8 Product Customer Service B-2

Glossary Glossary-1

Index Index-1

List of Figures

Figure 2-1. DC Voltage Routing Block Diagram.....	2-9
Figure 2-2. ASTRO Spectra B+ Routing for Vocoder/Controller (VOCON) Board.....	2-10
Figure 3-1. Prescaler IC Block Diagram	3-2
Figure 3-2. Synthesizer IC Block Diagram.....	3-2
Figure 3-3. Loop Divider Waveforms	3-4
Figure 3-4. Loop Filter Schematic.....	3-5
Figure 3-5. Power-on Reset.....	3-11
Figure 3-6. Transmitter Attack Time.....	3-14
Figure 3-7. VOCON Board - Controller Section	3-16
Figure 3-8. VOCON Board - Vocoder Section	3-18
Figure 3-9. DSP RSSI Port - RX Mode	3-19
Figure 3-10. DSP RSSI Port - TX Mode	3-21
Figure 3-11. Host SB9600 and RS232 Ports	3-23
Figure 3-12. Controller Memory Mapping	3-25
Figure 3-13. Vocoder Memory Mapping.....	3-27
Figure 3-14. ASTRO Spectra Plus VOCON Board - Controller Section	3-39
Figure 3-15. ASTRO Spectra Plus VOCON Board - Vocoder Section.....	3-40
Figure 3-16. ASTRO Spectra Plus RX Signal Path	3-41
Figure 3-17. ASTRO Spectra Plus TX Signal Path.....	3-42
Figure 3-18. ASTRO Spectra Plus Host SB9600 and RS232 Ports	3-44
Figure 3-19. ASTRO Spectra Plus VOCON DC Distribution.....	3-45
Figure 3-20. RPCIC Block Diagram	3-57
Figure 3-21. Regulator/Power Control IC Block Diagram	3-61
Figure 3-22. 50-Watt Power Amplifier Block Diagram	3-63
Figure 3-23. Regulator/Power Control IC Block Diagram	3-65
Figure 3-24. UHF High-Power, Power Amplifier Block Diagram	3-68
Figure 3-25. RPCIC Block Diagram	3-70
Figure 3-26. RPCIC Block Diagram	3-74
Figure 3-27. RPCIC Block Diagram	3-79
Figure 4-1. VCO Block Diagram—VHF Band	4-14
Figure 4-2. VCO Block Diagram—UHF Band	4-17
Figure 4-3. VCO Block Diagram—800 MHz Band.....	4-18
Figure 4-4. Connector Pin-Out—High-Power Amplifier	4-22
Figure 4-5. PA Test Adapter, 25/10 Watt Power Amplifier.....	4-31
Figure 4-6. PA Test Adapter, 50 Watt Power Amplifier.....	4-40
Figure 4-7. Connector Pin-Out—High-Power Amplifier	4-48
Figure 4-8. Block Diagram for Spectra High-Power Power Amplifier.....	4-56
Figure 4-9. PA Test Adapter, 40 Watt Power Amplifier.....	4-58
Figure 4-10. PA Test Adapter, 15 and 35 Watt Power Amplifier.....	4-67

A listing of schematics and component location diagrams can be found in the Table of Contents and [Table 7-1 on page 7-1 of Chapter 7 Schematics, Component Location Diagrams and Parts Lists.](#)

List of Tables

Table 3-1.	Integrated Circuits Voltages.....	3-10
Table 3-2.	VOCON Board Address Bus (A) Pinouts.....	3-29
Table 3-3.	VOCON Board Address Bus (HA) Pinouts.....	3-30
Table 3-4.	VOCON Board Data Bus (D) Pinouts.....	3-30
Table 3-5.	VOCON Board Data Bus (HD) Pinouts.....	3-31
Table 3-6.	U204 (MCU).....	3-32
Table 3-7.	U206 (SLIC).....	3-33
Table 3-8.	VOCON U405 (DSP).....	3-35
Table 3-9.	VOCON U406 (ADSIC).....	3-36
Table 4-1.	Power-Up Self-Check Error Codes.....	4-2
Table 4-2.	Voltage by Location.....	4-5
Table 4-3.	Feedback Frequency Ranges.....	4-7
Table 4-4.	Standard Operating Bias.....	4-9
Table 4-5.	ASTRO Spectra Plus Power-Up Self-Check Error Codes.....	4-10
Table 4-6.	ASTRO Spectra Plus Standard Operating Bias.....	4-12
Table 4-7.	VCO Frequency.....	4-15
Table 4-8.	Power Control DC Voltage Chart.....	4-23
Table 4-9.	LLA and 2nd Stage Typical Voltages.....	4-26
Table 4-10.	DC Voltages and Input Power Chart.....	4-30
Table 4-11.	Power Control DC Voltage Chart.....	4-31
Table 4-12.	Antenna Switch DC Voltage Chart.....	4-34
Table 4-13.	LLA and Driver Typical Voltages.....	4-35
Table 4-14.	DC Voltages and Input Power Chart.....	4-39
Table 4-15.	Power Control DC Voltage Chart.....	4-40
Table 4-16.	LLA and Pre-Driver Typical Voltages.....	4-43
Table 4-17.	Power Control DC Voltage Chart.....	4-49
Table 4-18.	LLA and 2nd Stage Typical Voltages.....	4-52
Table 4-19.	DC Voltages and Input Power Chart.....	4-58
Table 4-20.	Power Control DC Voltage Chart.....	4-59
Table 4-21.	Antenna Switch DC Voltage Chart.....	4-61
Table 4-22.	LLA and Pre-Driver Typical Voltages.....	4-62
Table 4-23.	DC Voltages and Input Power Chart.....	4-67
Table 4-24.	Power Control DC Voltage Chart.....	4-68
Table 4-25.	Antenna Switch DC Voltage Chart.....	4-71
Table 5-1.	List of Troubleshooting Charts.....	5-1
Table 6-1.	List of Troubleshooting Waveforms.....	6-1
Table 7-1.	List of Schematics and Component Location Diagrams.....	7-1
Table 7-2.	J500 Command Board to RF Board.....	7-2
Table 7-3.	P502 Command Board to Control Head Interconnect Board.....	7-2
Table 7-4.	P503 Command Board to RF Power Amplifier Board.....	7-2
Table 7-6.	J501 Command Board to VOCON Board.....	7-3
Table 7-5.	Configuring Command Board Jumpers for Non-RS232 Operation.....	7-3
Table 7-7.	J801 VOCON Board to Encryption Board.....	7-3
Table 7-8.	J601 RF Board to VCO Board.....	7-3
Table A-1.	ASTRO Digital Spectra Secure Modules.....	A-1
Table A-2.	ASTRO Digital Spectra Plus Secure Modules.....	A-1

Related Publications

ASTRO Digital Spectra and Digital Spectra Plus Model W3 User's Guide	6881090C61
ASTRO Digital Spectra and Digital Spectra Plus Models W4, W5, W7, and W9 User's Guide	6881090C62
ASTRO Digital Spectra Hand-Held Control Head User's Guide (Model W3)	6881073C25
ASTRO Digital Spectra (Model W4, W5, W7, and W9) User's Guide	6881074C80
ASTRO Digital Spectra and Digital Spectra Plus Mobile Radios Basic Service Manual	6881076C20
ASTRO Digital Spectra Mobile Radios Dual Control Head Radio System Service Manual	6881091C78
ASTRO Spectra and Digital Spectra FM Two-Way Mobile Radios Installation Manual	6881070C85
ASTRO Spectra Motorcycle Radios Supplemental Installation Manual.....	6880103W01
KVL 3000 User's Manual.....	6881131E16
Spectra VHF VCO Section Detailed Service Manual Supplement	6881074C48
Spectra High-Power Power Amplifier Detailed Service Manual Supplement	6881077C25
Spectra Systems 9000 Control Unit Detailed Service Manual Supplement	6881077C30
Spectra A5 and A7 Control Head Instruction Manual	6881109C33
Spectra A4 Control Head Instruction Manual	6881109C34

Notes

Commercial Warranty

Limited Warranty

MOTOROLA COMMUNICATION PRODUCTS

I. What This Warranty Covers And For How Long

MOTOROLA INC. ("MOTOROLA") warrants the MOTOROLA manufactured Communication Products listed below ("Product") against defects in material and workmanship under normal use and service for a period of time from the date of purchase as scheduled below:

ASTRO Digital Spectra and Digital Spectra Plus Units	One (1) Year
Product Accessories	One (1) Year

Motorola, at its option, will at no charge either repair the Product (with new or reconditioned parts), replace it (with a new or reconditioned Product), or refund the purchase price of the Product during the warranty period provided it is returned in accordance with the terms of this warranty. Replaced parts or boards are warranted for the balance of the original applicable warranty period. All replaced parts of Product shall become the property of MOTOROLA.

This express limited warranty is extended by MOTOROLA to the original end user purchaser only and is not assignable or transferable to any other party. This is the complete warranty for the Product manufactured by MOTOROLA. MOTOROLA assumes no obligations or liability for additions or modifications to this warranty unless made in writing and signed by an officer of MOTOROLA. Unless made in a separate agreement between MOTOROLA and the original end user purchaser, MOTOROLA does not warrant the installation, maintenance or service of the Product.

MOTOROLA cannot be responsible in any way for any ancillary equipment not furnished by MOTOROLA which is attached to or used in connection with the Product, or for operation of the Product with any ancillary equipment, and all such equipment is expressly excluded from this warranty. Because each system which may use the Product is unique, MOTOROLA disclaims liability for range, coverage, or operation of the system as a whole under this warranty.

II. General Provisions

This warranty sets forth the full extent of MOTOROLA's responsibilities regarding the Product. Repair, replacement or refund of the purchase price, at MOTOROLA's option, is the exclusive remedy. THIS WARRANTY IS GIVEN IN LIEU OF ALL OTHER EXPRESS WARRANTIES. IMPLIED WARRANTIES, INCLUDING WITHOUT LIMITATION, IMPLIED WARRANTIES OF MERCHANTABILITY AND FITNESS FOR A PARTICULAR PURPOSE, ARE LIMITED TO THE DURATION OF THIS LIMITED WARRANTY. IN NO EVENT SHALL MOTOROLA BE LIABLE FOR DAMAGES IN EXCESS OF THE PURCHASE PRICE OF THE PRODUCT, FOR ANY LOSS OF USE, LOSS OF TIME, INCONVENIENCE, COMMERCIAL LOSS, LOST PROFITS OR SAVINGS OR OTHER INCIDENTAL, SPECIAL OR CONSEQUENTIAL DAMAGES ARISING OUT OF THE USE OR INABILITY TO USE SUCH PRODUCT, TO THE FULL EXTENT SUCH MAY BE DISCLAIMED BY LAW.

III. State Law Rights

SOME STATES DO NOT ALLOW THE EXCLUSION OR LIMITATION OF INCIDENTAL OR CONSEQUENTIAL DAMAGES OR LIMITATION ON HOW LONG AN IMPLIED WARRANTY LASTS, SO THE ABOVE LIMITATION OR EXCLUSIONS MAY NOT APPLY.

This warranty gives specific legal rights, and there may be other rights which may vary from state to state.

IV. How To Get Warranty Service

You must provide proof of purchase (bearing the date of purchase and Product item serial number) in order to receive warranty service and, also, deliver or send the Product item, transportation and insurance prepaid, to an authorized warranty service location. Warranty service will be provided by Motorola through one of its authorized warranty service locations. If you first contact the company which sold you the Product, it can facilitate your obtaining warranty service. You can also call Motorola at 1-888-567-7347 US/Canada.

V. What This Warranty Does Not Cover

- A. Defects or damage resulting from use of the Product in other than its normal and customary manner.
- B. Defects or damage from misuse, accident, water, or neglect.
- C. Defects or damage from improper testing, operation, maintenance, installation, alteration, modification, or adjustment.
- D. Breakage or damage to antennas unless caused directly by defects in material workmanship.
- E. A Product subjected to unauthorized Product modifications, disassemblies or repairs (including, without limitation, the addition to the Product of non-Motorola supplied equipment) which adversely affect performance of the Product or interfere with Motorola's normal warranty inspection and testing of the Product to verify any warranty claim.
- F. Product which has had the serial number removed or made illegible.
- G. Rechargeable batteries if:
 - any of the seals on the battery enclosure of cells are broken or show evidence of tampering.
 - the damage or defect is caused by charging or using the battery in equipment or service other than the Product for which it is specified.
- H. Freight costs to the repair depot.
- I. A Product which, due to illegal or unauthorized alteration of the software/firmware in the Product, does not function in accordance with MOTOROLA's published specifications or the FCC type acceptance labeling in effect for the Product at the time the Product was initially distributed from MOTOROLA.
- J. Scratches or other cosmetic damage to Product surfaces that does not affect the operation of the Product.
- K. Normal and customary wear and tear.

VI. Patent And Software Provisions

MOTOROLA will defend, at its own expense, any suit brought against the end user purchaser to the extent that it is based on a claim that the Product or parts infringe a United States patent, and MOTOROLA will pay those costs and damages finally awarded against the end user purchaser in any such suit which are attributable to any such claim, but such defense and payments are conditioned on the following:

- A. that MOTOROLA will be notified promptly in writing by such purchaser of any notice of such claim;
- B. that MOTOROLA will have sole control of the defense of such suit and all negotiations for its settlement or compromise; and
- C. should the Product or parts become, or in MOTOROLA's opinion be likely to become, the subject of a claim of infringement of a United States patent, that such purchaser will permit MOTOROLA, at its option and expense, either to procure for such purchaser the right to continue using the Product or parts or to replace or modify the same so that it becomes non-infringing or to grant such purchaser a credit for the Product or parts as depreciated and accept its return. The depreciation will be an equal amount per year over the lifetime of the Product or parts as established by MOTOROLA.

MOTOROLA will have no liability with respect to any claim of patent infringement which is based upon the combination of the Product or parts furnished hereunder with software, apparatus or devices not furnished by MOTOROLA, nor will MOTOROLA have any liability for the use of ancillary equipment or software not furnished by MOTOROLA which is attached to or used in connection with the Product. The foregoing states the entire liability of MOTOROLA with respect to infringement of patents by the Product or any parts thereof.

Laws in the United States and other countries preserve for MOTOROLA certain exclusive rights for copyrighted MOTOROLA software such as the exclusive rights to reproduce in copies and distribute copies of such Motorola software. MOTOROLA software may be used in only the Product in which the software was originally embodied and such software in such Product may not be replaced, copied, distributed, modified in any way, or used to produce any derivative thereof. No other use including, without limitation, alteration, modification, reproduction, distribution, or reverse engineering of such MOTOROLA software or exercise of rights in such MOTOROLA software is permitted. No license is granted by implication, estoppel or otherwise under MOTOROLA patent rights or copyrights.

VII. Governing Law

This Warranty is governed by the laws of the State of Illinois, USA.

Notes

Model Numbering, Charts, and Specifications

Mobile Radio Model Numbering Scheme

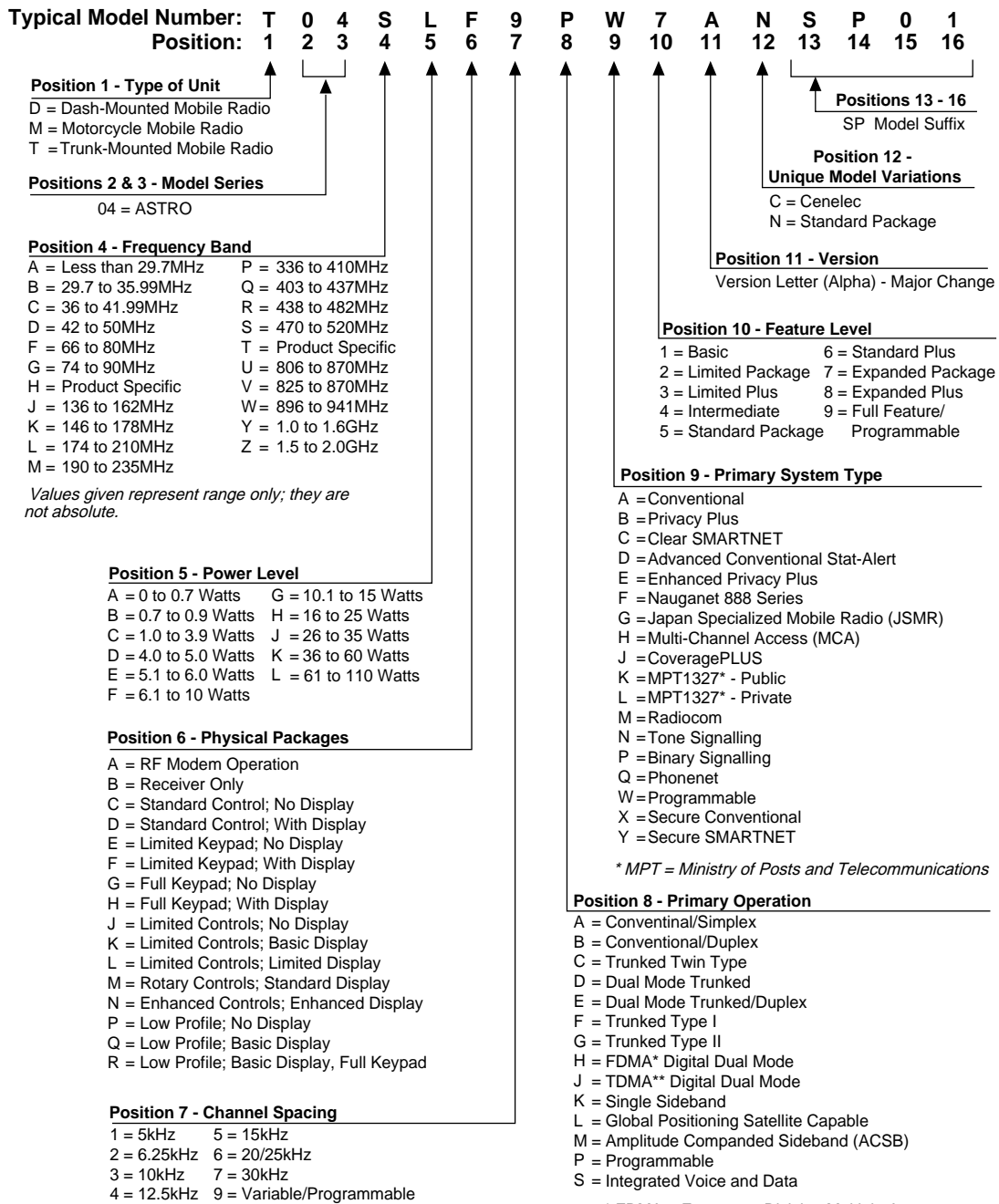

ASTRO Digital Spectra Motorcycle 15 Watt (Ranges 1 and 2) Model Chart

Model Number											Description	
M04JGF9PW4AN											Model W4 (136-162 MHz), Range 1, 15 Watt, 128 Channels	
M04JGF9PW5AN											Model W5 (136-162 MHz), Range 1, 15 Watt, 128 Channels	
M04JGH9PW7AN											Model W7 (136-162 MHz), Range 1, 15 Watt, 128 Channels	
M04KGF9PW4AN											Model W4 (146-174 MHz), Range 2, 15 Watt, 128 Channels	
M04KGF9PW5AN											Model W5 (146-174 MHz), Range 2, 15 Watt, 128 Channels	
M04KGH9PW7AN											Model W7 (146-174 MHz), Range 2, 15 Watt, 128 Channels	
M04RGF9PW4AN											Model W4 (438-470 MHz), Range 2, 15 Watt, 128 Channels	
M04RGF9PW5AN											Model W5 (438-470 MHz), Range 2, 15 Watt, 128 Channels	
M04RGH9PW7AN											Model W7 (438-470 MHz), Range 2, 15 Watt, 128 Channels	
M04UGF9PW4AN											Model W4 (800 MHz), 15 Watt, 128 Channels	
M04UGF9PW5AN											Model W5 (800 MHz), 15 Watt, 128 Channels	
M04UGH9PW7AN											Model W7 (800 MHz), 15 Watt, 128 Channels	
											Item No.	Description
X	X	X									HLD6066_	VHF Power Amplifier Board, 25-Watt
X	X	X	X	X	X	X	X	X	X	X	HKN6062_	Cable, Control Head to Radio
X	X	X									HLD4342_	VHF VCO Carrier
			X	X	X						HLD4343_	VHF VCO Carrier, CEPT
			X	X	X						HLD6032_	VHF Power Amplifier Board, Range 2, 25-Watt
X	X	X									HLD6061_	VHF VCO, Range 1, 136-162 MHz
			X	X	X						HLD6062_	VHF VCO Board, Range 2, 146-174 MHz
						X	X	X			HLE6046_	UHF VCO Carrier, Range 2
						X	X	X			HLE6062_	UHF RF Power Amplifier Board, Range 2, 25-Watt
						X	X	X			HLE6102_	UHF VCO Board, Range 2
								X	X	X	HLF6078_	800 MHz RF Power Amplifier Board, 15-Watt
								X	X	X	HLF6079_	800 MHz VCO Board
								X	X	X	HLF6080_	800 MHz VCO Carrier Board
X	X	X	X	X	X	X	X	X	X	X	HLN1368_	White Motorcycle Enclosure and Hardware
X	X	X	X	X	X	X	X	X	X	X	HLN6127_*	Low-Power Dash Hardware
X	X	X	X	X	X		X	X		X	HLN6193_	MPL Button Kit
X	X	X	X	X	X	X	X	X	X	X	HLN6342_*	Motorcycle Hardware
X	X	X	X	X	X	X	X	X	X	X	HLN6365_	Interface Board Kit
X	X	X	X	X	X	X	X	X	X	X	HLN6418_*	Transceiver Hardware
	X	X		X					X		HLN6444_*	W5 Motorcycle Control Head Hardware
				X					X		HLN6445_*	W7 Motorcycle Control Head Hardware
	X										HLN6454_	Motorcycle Control Head Board Kit
X	X	X	X	X	X	X	X	X	X	X	HLN6458_	Vocoder Controller
X			X								HLN6459_	Interface Board
		X		X					X		HLN6523_*	W7 Button Kit
	X			X					X		HLN6548_*	W5 Button Kit
					X				X		HLN6549_*	W4 Button Kit
X	X	X	X	X	X	X	X	X	X	X	HLN6562_	Motorcycle Command Board Kit
	X	X		X	X		X	X	X	X	HLN6563_	Motorcycle Control Head
X			X						X		HLN6571_	Spare Button Kit
X	X	X	X	X	X	X	X	X	X	X	HMN1079_	Weatherproof Microphone
X	X	X									HRD6001_	VHF Receiver Board, Range 1, Standard
			X	X	X						HRD6002_	VHF Receiver Board, Range 2, Standard
						X	X	X			HRE6002_	UHF Receiver Board, Range 2, Standard
								X	X	X	HRF6004_	800 MHz RX Front-End
			X	X	X						HRN4009_	VHF RF Board
						X	X	X			HRN4010_	UHF RF Board
X	X	X									HRN6014_	VHF RF Board, ASTRO
								X	X	X	HRN6019_	800 MHz RF Board, ASTRO
X	X	X	X	X	X	X	X	X	X	X	HSN6003_	Weatherproof Speaker
X			X					X			PMLN4019_	W4 Motorcycle Control Head
								X			RAE4024_	UHF Antenna, Quarterwave
							X	X	X		RAF4011_	800 MHz Antenna, 3 dB Gain

X = Item Included

_ = the latest version kit. When ordering a kit, refer to your specific kit for the suffix number.

* = kit not available. Order piece parts from the Customer Care and Services Division.

ASTRO Digital Spectra Motorcycle 15 Watt (Ranges 3 and 3.5) Model Chart

Model Number					Description
M04RGF9PW4ANSP02					Model W4 (450-482 MHz), Range 3, 15 Watt, 128 Channels
M04RGF9PW5ANSP02					Model W5 (450-482 MHz), Range 3, 15 Watt, 128 Channels
M04RGF9PW4ANSP01					Model W4 (453-488 MHz), Range 3.5, 15 Watt, 128 Channels
M04RGF9PW5ANSP01					Model W5 (453-488 MHz), Range 3.5, 15 Watt, 128 Channels
M04RGH9PW7ANSP01					Model W7 (453-488 MHz), Range 3.5, 15 Watt, 128 Channels
Item No.					Description
X	X	X	X	X	HKN6062_ Cable, Control Head to Radio
X	X				HLE6000_ UHF VCO Carrier, Range 3
		X	X	X	HLE6000_SP01 UHF VCO Carrier, Range 3.5
X	X				HLE6043_ UHF RF Power Amplifier Board, Range 3, 40-Watt
		X	X	X	HLE6043_SP01 UHF RF Power Amplifier Board, Range 3.5, 40-Watt
X	X				HLE6103_ UHF VCO Hybrid, Range 3
		X	X	X	HLE6103_SP01 UHF VCO Hybrid, Range 3.5
X	X	X	X	X	HLN1368_ White Motorcycle Enclosure and Hardware
X	X	X	X	X	HLN6127_* Low-Power Dash Hardware
	X		X	X	HLN6193_ MPL Button Kit
X	X	X	X	X	HLN6342_* Motorcycle Hardware
X	X	X	X	X	HLN6365_ Interface Board Kit
X	X	X	X	X	HLN6418_* Transceiver Hardware
	X		X		HLN6444_* W5 Motorcycle Control Head Hardware
				X	HLN6445_* W7 Motorcycle Control Head Hardware
X	X	X	X	X	HLN6458_ Vocoder Controller
				X	HLN6523_* W7 Button Kit
	X		X		HLN6548_* W5 Button Kit
X		X			HLN6549_* W4 Button Kit
X	X	X	X	X	HLN6562_ Motorcycle Command Board Kit
	X		X	X	HLN6563_ Motorcycle Control Head
X	X	X	X	X	HLN6571_ Spare Button Kit
X	X	X	X	X	HMN1079_ Weatherproof Microphone
X	X				HRE6003_ UHF Receiver Board, Range 3, Standard
		X	X	X	HRE6003_SP01 UHF Receiver Board, Range 3.5, Standard
X	X	X	X	X	HRN6020_ UHF RF Board, ASTRO
X	X	X	X	X	HSN6003_ Weatherproof Speaker
X		X			PMLN4019_ W4 Motorcycle Control Head
X	X	X	X	X	RAE4024_ UHF Antenna, Quarterwave

X = Item Included

_ = the latest version kit. When ordering a kit, refer to your specific kit for the suffix number.

* = kit not available. Order piece parts from the Customer Care and Services Division.

ASTRO Digital Spectra VHF 10–25 Watt Model Chart

Model Number										Description	
D04JHH9PW3AN										Model W3 (136-145.9 MHz), 10-25 Watt, 255 Channels	
D04JHF9PW4AN										Model W4 (136-162 MHz), 10-25 Watt, 128 Channels	
D04JHF9PW5AN										Model W5 (136-162 MHz); 10-25 Watt, 128 Channels	
D04JHH9PW7AN										Model W7 (136-162 MHz), 10-25 Watt, 255 Channels	
T04JHH9PW9AN										Model W9 (136-162 MHz), 10-25 Watt, 255 Channels	
D04KHH9PW3AN										Model W3 (136-145.9 MHz), 10-25 Watt, 255 Channels	
D04KHF9PW4AN										Model W4 (146-174 MHz), 10-25 Watt, 128 Channels	
D04KHF9PW5AN										Model W5 (146-174 MHz), 10-25 Watt, 128 Channels	
D04KHH9PW7AN										Model W7 (146-174 MHz), 10-25 Watt, 255 Channels	
T04KHH9PW9AN										Model W9 (146-174 MHz), 10-25 Watt, 255 Channels	
Item No.										Description	
X	X	X	X	X						HRD6001_	Front-End Receiver Board Kit (Range 1, 136-162 MHz)
					X	X	X	X		HRD6002_	Front-End Receiver Board Kit (Range 2, 146-174 MHz)
X	X	X	X	X		X	X	X		HRN6014_	RF Board Kit
X	X	X	X	X		X	X	X	X	HLD4342_	VCO Board Kit
X	X	X	X	X						HLD6061_	VCO Hybrid Kit (Range 1, 136-162 MHz)
					X	X	X	X	X	HLD6062_	VCO Hybrid Kit (Range 2, 146-174 MHz)
X	X	X	X	X	X	X	X	X	X	HLN5558_	Command Board Kit
X	X	X	X	X	X	X	X	X	X	HLN6458_	VOCON Board Kit
X	X	X	X	X		X	X	X	X	HLD6066_	Power Amplifier Board
				X					X	HLN6344_	Interface Board
	X	X	X			X	X	X		HLN6401_	Control Head Interconnect Board
	X					X				AAHN4045_	W4 Control Head
		X	X				X	X		HLN6396_	W5,W7 Control Head Board
				X					X	HCN1078_	W9 Control Head
	X	X	X			X	X	X		HMN1080_	Microphone
				X					X	HMN1061_	Microphone
X	X	X	X	X	X	X	X	X	X	HSN4018_	Speaker
				X					X	HLN4921_	Control Head (W9) Trunnion
				X					X	HLN5488_	Radio Microphone Installation Hardware (W9 Trunnion)
X	X	X	X		X	X	X	X		HLN6015_	Trunnion/Hardware (Dash Mount)
	X	X	X			X	X	X		HLN6060_	Dash-Mount Hardware
X				X	X				X	HLN6185_*	Remote-Mount, SECURENET Control-Head Hardware
X	X	X	X	X	X	X	X	X	X	HLN6418_*	Transceiver Hardware
		X					X			HLN6440_*	Control Head without Keypad Hardware
			X					X		HLN6441_*	Control Head with Keypad Hardware
					X					HLN6493_*	Plug Kit
				X					X	HLN4952_	Fuse Kit
				X					X	HKN4356_	Radio Cable (Length - 17 Feet)
X	X	X	X		X	X	X	X		HKN4191_	Power Cable (Length - 20 Feet)
				X					X	HKN4192_	Power Cable (Length - 20 Feet)
				X					X	HLN6481_*	Systems 9000 E9 Clear Button Kit
	X					X				HLN6549_*	C4 Button Kit
	X					X				HLN6105_	Emergency/Secure/MPL Button Kit
		X	X				X	X		HLN6193_	Emergency/MPL Field Option Button Kit
		X					X			HLN6548_*	SMARTNET Button Kit
			X					X		HLN6523_*	SMARTNET Button Kit
				X					X	HLN6167_	Option Button Kit
					X					HLD4343_	VCO Board Kit; VHF CEPT
					X					HLD6032_	Power Amplifier Board Kit
X					X					HLN6127_	Hardware, Radio Dash Low-Power
X					X					HLN6459_	W3 Interface Board
X					X					HMN4044_	ASTRO Handheld Control Head (W3)
					X					HRN4009_	RF Board Kit

X = Item Included
 _ = the latest version kit. When ordering a kit, refer to your specific kit for the suffix number.
 * = kit not available. Order piece parts from the Customer Care and Services Division.

ASTRO Digital Spectra VHF 25–50 and 50–110 Watt Model Chart

Model Number													Description	
D04JKH9PW3AN													Model W3 (136-145.9 MHz), 25-50 Watt, 128 Channels	
D04JKF9PW4AN													Model W4 (136-162 MHz), 25-50 Watt, 128 Channels	
D04JKF9PW5AN													Model W5 (136-162 MHz); 25-50 Watt, 128 Channels	
D04JKH9PW7AN													Model W7 (136-162 MHz), 25-50 Watt, 255 Channels	
T04JKH9PW9AN													Model W9 (136-162 MHz), 25-50 Watt, 255 Channels	
D04KKF9PW3AN													Model W3 (146-174 MHz), 25-50 Watt, 128 Channels	
D04KKF9PW4AN													Model W4 (146-174 MHz), 25-50 Watt, 128 Channels	
D04KKF9PW5AN													Model W5 (146-174 MHz), 25-50 Watt, 128 Channels	
D04KKH9PW7AN													Model W7 (146-174 MHz), 25-50 Watt, 255 Channels	
T04KKH9PW9AN													Model W9 (146-174 MHz), 25-50 Watt, 255 Channels	
T04JLH9PW3AN													Model W3 (136-145.9 MHz), 50-110 Watt, 128 Channels	
T04JLF9PW4AN													Model W4 (136-162 MHz), 50-110 Watt, 128 Channels	
T04JLF9PW5AN													Model W5 (136-162 MHz), 50-110 Watt, 128 Channels	
T04JLH9PW7AN													Model W7 (136-162 MHz), 50-110 Watt, 255 Channels	
T04JLH9PW9AN													Model W9 (136-162 MHz), 50-110 Watt, 255 Channels	
T04KLH9PW3AN													Model W3 (146-174 MHz), 50-110 Watt, 255 Channels	
T04KLF9PW4AN													Model W4 (146-174 MHz), 50-110 Watt, 128 Channels	
T04KLF9PW5AN													Model W5 (146-174 MHz), 50-110 Watt, 128 Channels	
T04KLH9PW7AN													Model W7 (146-174 MHz), 50-110 Watt, 255 Channels	
T04KLH9PW9AN													Model W9 (146-174 MHz), 50-110 Watt, 255 Channels	
													Item No.	
													Description	
X	X	X	X	X					X	X	X	X	HRD6001_	Front-End Rcvr Board Kit (Range 1, 136-162 MHz)
				X	X	X	X	X		X	X	X	HRD6002_	Front-End Rcvr Board Kit (Range 2, 146-174 MHz)
X	X	X	X	X	X	X	X	X	X	X	X	X	HRN6014_	RF Board Kit
X	X	X	X	X	X	X	X	X	X	X	X	X	HLD4342_	VCO Board Kit
X	X	X	X	X					X	X	X	X	HLD6061_	VCO Hybrid Kit (Range 1, 136-162 MHz)
				X	X	X	X	X		X	X	X	HLD6062_	VCO Hybrid Kit (Range 2, 146-174 MHz)
X	X	X	X	X	X	X	X	X	X	X	X	X	HLN5558_	Command Board Kit
X	X	X	X	X	X	X	X	X	X	X	X	X	HLN6458_	VOCON Board Kit
								X	X	X	X		HLD6064_	Power Amplifier Board (50-110W, Range 1, 136-162 MHz)
X	X	X	X	X	X	X	X	X					HLD6022_	Power Amplifier Board (25-50W, Range 1, 136-174 MHz)
									X	X	X	X	HLD6063_	Power Amplifier Board (50-110W, Range 2, 146-174 MHz)
			X										HLN6344_	Interface Board
X	X	X	X	X	X	X							HLN6401_	Control Head Interconnect Board
X			X						X				AAHN4045_	W4 Control Head
							X	X	X	X			HLN6486_	High-Power Interconnect Board
							X	X	X				HLN6432_	Control Head Back Housing
	X	X			X	X				X	X		HLN6396_	W5,W7 Control Head Board
		X			X			X				X	HCN1078_	W9 Control Head
X	X	X	X	X	X	X			X	X	X		HMN1080_	Microphone
			X			X						X	HMN1061_	Microphone
X	X	X	X	X	X	X	X	X					HSN4018_	Speaker
						X	X	X	X	X	X	X	HSN6001_	Speaker
			X			X						X	HLN4921_	Control Head (W9) Trunnion
			X			X							HLN5488_	Radio Microphone Installation Hardware (W9 Trunnion)
X			X	X		X							HLN6185_*	Rem-Mount, SECURENET Control-Head Hardware
							X	X	X				HLN6231_	Remote W4, W5, W7 Control-Head Trunnion
						X	X	X	X	X	X	X	HLN6233_*	Option Connector Hardware

X = Item Included

_ = the latest version kit. When ordering a kit, refer to your specific kit for the suffix number.

* = kit not available. Order piece parts from the Customer Care and Services Division.

ASTRO Digital Spectra VHF 25–50 and 50–110 Watt Model Chart (cont.)

Model Number														Description		
D04JKH9PW3AN														Model W3 (136-145.9 MHz), 25-50 Watt, 128 Channels		
D04JKF9PW4AN														Model W4 (136-162 MHz), 25-50 Watt, 128 Channels		
D04JKF9PW5AN														Model W5 (136-162 MHz); 25-50 Watt, 128 Channels		
D04JKH9PW7AN														Model W7 (136-162 MHz), 25-50 Watt, 255 Channels		
T04JKH9PW9AN														Model W9 (136-162 MHz), 25-50 Watt, 255 Channels		
D04KKF9PW3AN														Model W3 (146-174 MHz), 25-50 Watt, 128 Channels		
D04KKF9PW4AN														Model W4 (146-174 MHz), 25-50 Watt, 128 Channels		
D04KKF9PW5AN														Model W5 (146-174 MHz), 25-50 Watt, 128 Channels		
D04KKH9PW7AN														Model W7 (146-174 MHz), 25-50 Watt, 255 Channels		
T04KKH9PW9AN														Model W9 (146-174 MHz), 25-50 Watt, 255 Channels		
T04JLH9PW3AN														Model W3 (136-145.9 MHz), 50-110 Watt, 128 Channels		
T04JLF9PW4AN														Model W4 (136-162 MHz), 50-110 Watt, 128 Channels		
T04JLF9PW5AN														Model W5 (136-162 MHz), 50-110 Watt, 128 Channels		
T04JLH9PW7AN														Model W7 (136-162 MHz), 50-110 Watt, 255 Channels		
T04JLH9PW9AN														Model W9 (136-162 MHz), 50-110 Watt, 255 Channels		
T04KLH9PW3AN														Model W3 (146-174 MHz), 50-110 Watt, 255 Channels		
T04KLF9PW4AN														Model W4 (146-174 MHz), 50-110 Watt, 128 Channels		
T04KLF9PW5AN														Model W5 (146-174 MHz), 50-110 Watt, 128 Channels		
T04KLH9PW7AN														Model W7 (146-174 MHz), 50-110 Watt, 255 Channels		
T04KLH9PW9AN														Model W9 (146-174 MHz), 50-110 Watt, 255 Channels		
														Item No.	Description	
														X	HLN6132_*	High-Power Installation Hardware
X	X	X	X	X	X	X	X	X	X	X	X	X	X	X	HLN6015_	Trunion/Hardware (Dash Mount)
X	X	X	X	X	X	X	X	X	X	X	X	X	X	X	HLN6060_	Dash-Mount Hardware
														X	HLN6121_*	High-Power Radio Hardware
X	X	X	X	X	X	X	X	X	X	X	X	X	X	X	HLN6418_*	Transceiver Hardware
														X	HLN6440_*	Control Head without Keypad Hardware
														X	HLN6441_*	Control Head with Keypad Hardware
														X	HLN6525_*	High-Power Transceiver Hardware
														X	HLN6493_*	Plug Kit
														X	HLN4952_	Fuse Kit
														X	HKN4356_	Radio Cable (Length - 17 Feet)
														X	HKN6039_	Cable (Length - 17 Feet)
														X	HKN4051_	Cable and Fuse
X	X	X	X	X	X	X	X	X	X	X	X	X	X	X	HKN4191_	Power Cable (Length - 20 Feet)
														X	HKN4192_	Power Cable (Length - 20 Feet)
														X	HLN6481_*	Systems 9000 E9 Clear Button Kit
														X	HLN6549_*	C4 Button Kit
														X	HLN6105_	Emergency/Secure/MPL Button Kit
														X	HLN6193_	Emergency/MPL Field Option Button Kit
														X	HLN6548_*	SMARTNET Button Kit
														X	HLN6523_*	SMARTNET Button Kit
														X	HLN6167_	Option Button Kit
X														X	HLN6459_	W3 Interface Board Kit
X														X	HMN4044_	ASTRO Handheld Control Head (W3)
X														X	TLN5277_	Filter Kit
														X	HKN6096_	Handheld Control Head Y Cable Kit
														X	HLN6291_	Installation Hardware Kit
														X	HLN6574_	W3 Interconnect Board Kit

X = Item Included
 _ = the latest version kit. When ordering a kit, refer to your specific kit for the suffix number.
 * = kit not available. Order piece parts from the Customer Care and Services Division.

ASTRO Digital Spectra UHF 10–25 Watt Model Chart

Model Number					Description	
D04RHH9PW3AN					Model W3 (438-470 MHz), 10-25 Watt, 255 Channels	
D04RHF9PW4AN					Model W4 (438-470 MHz), 10-25 Watt, 128 Channels	
D04RHF9PW5AN					Model W5 (438-470 MHz), 10-25 Watt, 128 Channels	
D04RHH9PW7AN					Model W7 (438-470 MHz), 10-25 Watt, 255 Channels	
T04RHH9PW9AN					Model W9 (438-470 MHz), 10-25 Watt, 255 Channels	
Item No.					Description	
	X				AAHN4045_	Front Housing
X	X	X	X	X	HAE4003_	Antenna
X	X	X	X		HKN4191_	Power Cable (Length - 20 Feet)
X	X	X	X	X	HLE6046_	VCO Carrier, Range 2
X	X	X	X	X	HLE6062_	Power Amplifier, 25W, Range 2
X	X	X	X	X	HLE6102_	VCO Hybrid Kit, Range 2
X	X	X	X	X	HLN5558_	Command Board Kit
X	X	X	X		HLN6015_	Trunnion
	X	X	X		HLN6073_	Dash-Mount Hardware
	X				HLN6105_	Emergency/Secure/MPL Button Kit
	X				HLN6549_*	C4 Button Kit
	X	X	X		HLN6401_	Control Head Interconnect Board
X	X	X	X	X	HLN6418_*	Transceiver Hardware
X	X	X	X	X	HLN6458_	VOCODER Controller
	X	X	X		HMN1080_	Microphone
X	X	X	X	X	HRE6002_	Receiver, Range 2
	X	X	X	X	HRN6020_	RF Board Kit
X	X	X	X	X	HSN4018_	Speaker
		X			HLN6548_*	SMARTNET Button Kit
		X	X		HLN6193_	Emergency/MPL Field Option Button Kit
		X	X		HLN6396_	DEK Compatible Control Head
		X			HLN6440_*	Control Head without Keypad Hardware
			X		HLN6441_*	Control Head with Keypad Hardware
			X		HLN6523_*	SMARTNET Button Kit
				X	HCN1078_	W9 Control Head
				X	HKN4192_	Power Cable (Length - 20 Feet)
				X	HKN4356_	Radio Cable
				X	HLN4921_	Trunnion
				X	HLN4952_	Fuse Kit
				X	HLN5488_	Installation Hardware
				X	HLN6162_*	Remote Hardware
				X	HLN6167_	Option Button Kit
X				X	HSN6185_	Remote-Mount, SECURENET Control-Head Hardware
				X	HLN6344_	Interface Board
				X	HLN6481_*	Systems 9000 E9 Clear Button Kit
				X	HLN6493_*	Plug Kit
				X	HMN1061_	Microphone
X					HLN6127_	Dash Hardware, Low-Power Kit
X					HLN6459_	W3 Interface Board Kit
X					HMN4044_	ASTRO Handheld Control Head (W3)
X					HRN4010_	Low-Power RF Board Kit
X					TLN5277_	Filter Kit

X = Item Included

_ = the latest version kit. When ordering a kit, refer to your specific kit for the suffix number.

* = kit not available. Order piece parts from the Customer Care and Services Division.

ASTRO Digital Spectra UHF 20–40 Watt Model Chart (cont.)

Model Number													Description						
D04QKH9PW3AN													Model W3 (403-433 MHz), 20-40 Watt, 128 Channels						
D04QKF9PW4AN													Model W4 (403-433 MHz), 20-40 Watt, 128 Channels						
D04QKF9PW5AN													Model W5 (403-433 MHz), 20-40 Watt, 128 Channels						
D04QKH9PW7AN													Model W7 (403-433 MHz), 20-40 Watt, 255 Channels						
T04QKH9PW9AN													Model W9 (403-433 MHz), 20-40 Watt, 255 Channels						
D04RKH9PW3ANSP01													Model W3 (450-482 MHz), 20-40 Watt, 128 Channels						
D04RKF9PW4AN													Model W4 (450-482 MHz), 20-40 Watt, 128 Channels						
D04RKF9PW5AN													Model W5 (450-482 MHz), 20-40 Watt, 128 Channels						
D04RKH9PW7AN													Model W7 (450-482 MHz), 20-40 Watt, 255 Channels						
T04RKH9PW9AN													Model W9 (450-482 MHz), 20-40 Watt, 255 Channels						
D04SKH9PW3AN													Model W3 (482-512 MHz), 20-40 Watt, 128 Channels						
D04SKF9PW4AN													Model W4 (482-512 MHz), 20-40 Watt, 128 Channels						
D04SKF9PW5AN													Model W5 (482-512 MHz), 20-40 Watt, 128 Channels						
D04SKH9PW7AN													Model W7 (482-512 MHz), 20-40 Watt, 255 Channels						
T04SKH9PW9AN													Model W9 (482-512 MHz), 20-40 Watt, 255 Channels						
													Item No.	Description					
				X	X	X	X	X										HAE4003_	Antenna, Quarterwave
					X	X	X	X										HLE6000_	VCO Carrier, Range 3
					X	X	X	X										HLE6043_	Power Amplifier, 40W, Range 3
					X	X	X	X										HLE6103_	VCO Hybrid Kit, Range 3
					X	X	X	X										HRE6003_	Receiver F/E, Range 3
X	X	X	X	X	X	X	X	X	X	X	X	X	X	X				HSN4018_	Speaker
				X					X									HCN1078_	W9 Control Head
									X	X	X	X	X					HAE4004_	Antenna, Roof Top
									X	X	X	X	X					HLE6041_	VCO Carrier, Range 4
									X	X	X	X	X					HLE6044_	Power Amplifier, 40W, Range 4
									X	X	X	X	X					HLE6104_	VCO Hybrid Kit, Range 4
									X	X	X	X	X					HRE6004_	Receiver F/E, Range 4
X					X				X									HLN6459_	W3 Interface Board
X					X				X									HMN4044_	ASTRO Handheld Control Head (W3)

X = Item Included

_ = the latest version kit. When ordering a kit, refer to your specific kit for the suffix number.

* = kit not available. Order piece parts from the Customer Care and Services Division.

ASTRO Digital Spectra UHF 50–110 Watt Model Chart

Model Number										Description		
T04QLF9PW4AN										Model W4 (403-433 MHz), 50-110 Watt, 128 Channels		
T04QLF9PW5AN										Model W5 (403-433 MHz), 50-110 Watt, 255 Channels		
T04QLH9PW7AN										Model W7 (403-433 MHz), 50-110 Watt, 255 Channels		
T04QLH9PW9AN										Model W9 (403-433 MHz), 50-110 Watt, 255 Channels		
T04RLF9PW4AN										Model W4 (450-482 MHz), 50-110 Watt, 128 Channels		
T04RLF9PW5AN										Model W5 (450-482 MHz), 50-110 Watt, 128 Channels		
T04RLH9PW7AN										Model W7 (450-482 MHz), 50-110 Watt, 255 Channels		
T04RLH9PW9AN										Model W9 (450-482 MHz), 50-110 Watt, 255 Channels		
T04SLF9PW4AN										Model W4 (482-512 MHz), 50-110 Watt, 128 Channels		
T04SLF9PW5AN										Model W5 (482-512 MHz), 50-110 Watt, 128 Channels		
T04SLHPW7AN										Model W7 (482-512 MHz), 50-110 Watt, 128 Channels		
T04SLHPW9AN										Model W9 (482-512 MHz), 50-110 Watt, 128 Channels		
Item No.										Description		
X				X				X		AAHN4045_	Front Housing	
X	X	X	X							HAE4002_	Antenna, Roof Top	
				X	X	X	X			HAE4003_	Antenna, Quarterwave	
							X	X	X	X	HAE4004_ Antenna, Roof Top	
X	X	X	X	X	X	X	X	X	X	X	HKN4051_ Cable and Fuse	
X	X	X	X	X	X	X	X	X	X	X	HKN4356_ Radio Cable (Length - 17 Feet)	
X	X	X	X	X	X	X	X	X	X	X	HKN6039_ Cable (Length - 17 Feet)	
				X	X	X	X				HLE6039_ VCO Carrier, Range 3	
							X	X	X	X	HLE6040_ Power Amplifier Board, Range 4	
							X	X	X	X	HLE6041_ VCO Carrier, Range 4	
X	X	X	X								HLE6045_ VCO Carrier, Range 1	
X	X	X	X								HLE6051_ Power Amplifier Board, 100W, Range 1	
X	X	X	X								HLE6101_ VCO Hybrid Kit, Range 1	
				X	X	X	X				HLE6103_ VCO Hybrid Kit, Range 3	
							X	X	X	X	HLE6104_ VCO Hybrid Kit, Range 4	
X	X	X	X	X	X	X	X	X	X	X	HLN4952_ Fuse Kit	
X	X	X	X	X	X	X	X	X	X	X	HLN5558_ Command Board Kit	
X				X							HLN6105_ Emergency/Secure/MPL Button Kit	
X	X	X	X	X	X	X	X	X	X	X	HLN6121_* High-Power Radio Hardware	
X	X	X	X	X	X	X	X	X	X	X	HLN6132_* Installation Hardware, High-Power	
X	X	X		X	X	X		X	X	X	HLN6231_ Remote W4, W5, W7 Control-Head Trunion	
X	X	X	X	X	X	X	X	X	X	X	HLN6233_* Option Connector Hardware	
X				X							HLN6549_* C4 Button Kit	
X	X	X		X	X	X		X	X	X	HLN6432_ Back Housing, Control Head	
X	X	X	X	X	X	X	X	X	X	X	HLN6458_ VOCON Board Kit	
X	X	X	X	X	X	X	X	X	X	X	HLN6486_ Interconnect Board	
				X	X			X	X	X	HLN6493_* Plug Kit	
X	X	X	X	X	X	X	X	X	X	X	HLN6525_* High-Power Transceiver Hardware	
X	X	X	X	X	X			X	X	X	HMN1080_ Microphone	
X	X	X	X				X			X	HMN1061_ Microphone	
				X							HRE6001_ Receiver Board Kit, Range 1	
				X	X	X	X				HRE6003_ Receiver Board Kit, Range 3	
							X	X	X	X	HRE6004_ Receiver Board Kit, Range 4	
X	X	X	X	X	X	X	X	X	X	X	HRN6020_ RF Board	
X	X	X	X	X	X	X	X		X	X	HSN6001_ Speaker	
	X			X				X			HLN6548_* SMARTNET Button Kit	
	X	X		X	X			X	X		HLN6193_ Emergency/MPL Field Option Button Kit	
	X	X		X	X			X	X		HLN6396_ W5, W7 Control Head Board	

X = Item Included

_ = the latest version kit. When ordering a kit, refer to your specific kit for the suffix number.

* = kit not available. Order piece parts from the Customer Care and Services Division.

ASTRO Digital Spectra UHF 50–110 Watt Model Chart (cont.)

Model Number										Description			
T04QLF9PW4AN										Model W4 (403-433 MHz), 50-110 Watt, 128 Channels			
T04QLF9PW5AN										Model W5 (403-433 MHz), 50-110 Watt, 255 Channels			
T04QLH9PW7AN										Model W7 (403-433 MHz), 50-110 Watt, 255 Channels			
T04QLH9PW9AN										Model W9 (403-433 MHz), 50-110 Watt, 255 Channels			
T04RLF9PW4AN										Model W4 (450-482 MHz), 50-110 Watt, 128 Channels			
T04RLF9PW5AN										Model W5 (450-482 MHz), 50-110 Watt, 128 Channels			
T04RLH9PW7AN										Model W7 (450-482 MHz), 50-110 Watt, 255 Channels			
T04RLH9PW9AN										Model W9 (450-482 MHz), 50-110 Watt, 255 Channels			
T04SLF9PW4AN										Model W4 (482-512 MHz), 50-110 Watt, 128 Channels			
T04SLF9PW5AN										Model W5 (482-512 MHz), 50-110 Watt, 128 Channels			
T04SLHPW7AN										Model W7 (482-512 MHz), 50-110 Watt, 128 Channels			
T04SLHPW9AN										Model W9 (482-512 MHz), 50-110 Watt, 128 Channels			
										Item No.		Description	
	X				X			X			HLN6440_*	Control Head without Keypad Hardware	
		X			X			X			HLN6441_*	Control Head with Keypad Hardware	
		X			X			X			HLN6523_*	SMARTNET Button Kit	
			X			X			X		HCN1078_	W9 Control Head	
			X			X			X		HLN4921_	Trunnion	
			X			X			X		HLN6167_	Option Button Kit	
			X			X			X		HLN6481_*	Systems 9000 E9 Clear Button Kit	

X = Item Included

_ = the latest version kit. When ordering a kit, refer to your specific kit for the suffix number.

* = kit not available. Order piece parts from the Customer Care and Services Division.

ASTRO Digital Spectra 800 MHz Model Chart

Model Number					Description	
D04UJF9PW3AN					Model W3 (800 MHz), 35 Watt, 128 Channels	
D04UJF9PW4AN					Model W4 (800 MHz), 35 Watt, 128 Channels	
D04UJF9PW5AN					Model W5 (800 MHz), 35 Watt, 128 Channels	
D04UJF9PW7AN					Model W7 (800 MHz), 35 Watt, 255 Channels	
T04UJF9PW9AN					Model W9 (800 MHz), 35 Watt, 255 Channels	
Item No.					Description	
	X				AAHN4045_	Front Housing
X	X	X	X		HKN4191_	Power Cable (Length - 20 Feet)
X	X	X	X	X	HLF6077_	Power Amplifier
X	X	X	X	X	HLF6079_	VCO Hybrid
X	X	X	X	X	HLF6080_	VCO Carrier
X	X	X	X		HLN6015_	Trunnion/Hardware
	X				HLN6040_	Phon/Page/Emer/MPL Button
X	X	X	X	X	HLN6126_*	Mid-Power Dash Mount Radio Hardware
		X	X		HLN6193_	Emergency/MPL Field Option Button Kit
	X				HLN6549_*	C4 Button Kit
	X	X	X		HLN6401_	Control Head Interconnect Board
	X	X	X	X	HLN6418_*	Transceiver Hardware
	X	X	X		HMN1080_	Microphone
X	X	X	X	X	HRF6004_	Front-End Receiver Kit
X	X	X	X	X	HRN6019_	RF Board Kit
X	X	X	X	X	HSN4018_	Speaker
X	X	X	X	X	RRA4914_	Antenna
X	X	X	X	X	HLN5558_	Command Board Kit
		X			HLN6548_*	SMARTNET Button Kit
		X	X		HLN6396_	Control Head Deck Compatible
		X			HLN6440_*	Control Head without Keypad Hardware
X	X	X	X	X	HLN6458_	VOCODER Controller
			X		HLN6441_*	Control Head with Keypad Hardware
			X		HLN6523_*	SMARTNET Button Kit
				X	HCN1078_	W9 Control Head
				X	HKN4192_	Power Cable (Length - 20 Feet)
				X	HKN4356_	Radio Cable (Length - 17 Feet)
				X	HLN4921_	Trunnion, Control Head W9
				X	HLN4952_	Fuse Kit
				X	HLN5488_	Installation Hardware (W9 Trunnion) Radio Microphone
				X	HLN6167_	Option Button Kit
X				X	HLN6185_*	Remote-Mount, SECURENET Control Head Hardware
				X	HLN6344_	Interface Board
				X	HLN6481_*	Systems 9000 E9 Clear Button Kit
				X	HLN6493_*	Plug Kit
				X	HMN1061_	Microphone

X = Item Included

_ = the latest version kit. When ordering a kit, refer to your specific kit for the suffix number.

* = kit not available. Order piece parts from the Customer Care and Services Division.

ASTRO Digital Spectra Plus VHF 25–50 and 50–110 Watt Model Chart

Model Number										Description	
D04KKH9SW3AN										Model W3 (146-174 MHz), 25-50 Watt, 512 Channels	
D04KKF9SW4AN										Model W4 (146-174 MHz), 25-50 Watt, 512 Channels	
D04KKF9SW5AN										Model W5 (146-174 MHz); 25-50 Watt, 512 Channels	
D04KKH9SW7AN										Model W7 (146-174 MHz), 25-50 Watt, 512 Channels	
T04KKH9SW9AN										Model W9 (146-174 MHz), 25-50 Watt, 512 Channels	
T04KLH9SW3AN										Model W3 (146-174 MHz), 50-110 Watt, 512 Channels	
T04KLF9SW4AN										Model W4 (146-174 MHz), 50-110 Watt, 512 Channels	
T04KLF9SW5AN										Model W5 (146-174 MHz), 50-110 Watt, 512 Channels	
T04KLH9SW7AN										Model W7 (146-174 MHz), 50-110 Watt, 512 Channels	
T04KLH9SW9AN										Model W9 (146-174 MHz), 50-110 Watt, 512 Channels	
										Item No.	Description
X	X	X	X	X	X	X	X	X	X	HRD6002_	Front-End Rcvr Board Kit (Range 2, 146-174 MHz)
X	X	X	X	X	X	X	X	X	X	HRN6014_	RF Board Kit
X	X	X	X	X	X	X	X	X	X	HLD4342_	VCO Board Kit
X	X	X	X	X	X	X	X	X	X	HLD6062_	VCO Hybrid Kit (Range 2, 146-174 MHz)
X	X	X	X	X	X	X	X	X	X	HLN5558_	Command Board Kit
X	X	X	X	X	X	X	X	X	X	HLN6837_	VOCON Board Kit
X	X	X	X	X						HLD6022_	Power Amplifier Board (25-50W, Range 2, 146-174 MHz)
					X	X	X	X	X	HLD6063_	Power Amplifier Board (50-110W, Range 2, 146-174 MHz)
				X						HLN6344_	Interconnect Board, Remote, Mid-Power (W4–W9)
	X	X	X							HLN6401_	Interconnect Board, Dash-Mount (W4–W9)
X										HLN6459_	W3 Interconnect Board Kit (Mid-Power)
				X						HLN6574_	W3 Interconnect Board Kit (High-Power)
					X	X	X	X	X	HLN6486_	High-Power Interconnect Board (W4–W9)
					X	X	X			HLN6432_	Control Head Back Housing
X				X						HMN4044_	W3 ASTRO Handheld Control Head
	X				X					AAHN4045_	W4 Control Head
		X	X			X	X			HLN6396_	W5,W7 Control Head Board
				X					X	HCN1078_	W9 Control Head
O	O	O	O	O	O	O	O	O	O	NTN9801_	ASTRO Spectra Plus UCM
	X	X	X		X	X	X			HMN1080_	Microphone
				X					X	HMN1061_	Microphone
X	X	X	X	X						HSN4018_	Speaker
				X	X	X	X	X	X	HSN6001_	Speaker
				X					X	HLN4921_	Control Head (W9) Trunnion
				X					X	HLN5488_	Radio Microphone Installation Hardware (W9 Trunnion)
X				X						HLN6185_*	Rem-Mount, SECURENET Control-Head Hardware
					X	X	X			HLN6231_	Remote W4, W5, W7 Control-Head Trunnion
					X	X	X	X	X	HLN6233_*	Option Connector Hardware
					X	X	X	X	X	HLN6132_*	High-Power Installation Hardware
					X					HLN6291_	Installation Hardware Kit
X	X	X	X							HLN6015_	Trunnion/Hardware (Dash Mount)
X	X	X	X							HLN6060_	Dash-Mount Hardware
				X	X	X	X	X	X	HLN6121_*	High-Power Radio Hardware
X	X	X	X	X						HLN6866_*	Transceiver Hardware
		X				X				HLN6440_*	Control Head without Keypad Hardware
			X				X			HLN6441_*	Control Head with Keypad Hardware

X = Item Included

O = Optional item

_ = the latest version kit. When ordering a kit, refer to your specific kit for the suffix number.

* = kit not available. Order piece parts from the Customer Care and Services Division.

ASTRO Digital Spectra Plus VHF 25–50 and 50–110 Watt Model Chart (cont.)

Model Number								Description		
D04KKH9SW3AN								Model W3 (146-174 MHz), 25-50 Watt, 512 Channels		
D04KKF9SW4AN								Model W4 (146-174 MHz), 25-50 Watt, 512 Channels		
D04KKF9SW5AN								Model W5 (146-174 MHz); 25-50 Watt, 512 Channels		
D04KKH9SW7AN								Model W7 (146-174 MHz), 25-50 Watt, 512 Channels		
T04KKH9SW9AN								Model W9 (146-174 MHz), 25-50 Watt, 512 Channels		
T04KLH9SW3AN								Model W3 (146-174 MHz), 50-110 Watt, 512 Channels		
T04KLF9SW4AN								Model W4 (146-174 MHz), 50-110 Watt, 512 Channels		
T04KLF9SW5AN								Model W5 (146-174 MHz), 50-110 Watt, 512 Channels		
T04KLH9SW7AN								Model W7 (146-174 MHz), 50-110 Watt, 512 Channels		
T04KLH9SW9AN								Model W9 (146-174 MHz), 50-110 Watt, 512 Channels		
								Item No.	Description	
				X	X	X	X	X	HLN6525_*	High-Power Transceiver Hardware
			X					X	HLN6493_*	Plug Kit
			X		X	X	X	X	HLN4952_	Fuse Kit
			X		X	X	X	X	HKN4356_	Radio Cable (Length - 17 Feet)
				X	X	X	X	X	HKN4051_	Cable and Fuse
X	X	X	X						HKN4191_	Power Cable (Length - 20 Feet)
			X						HKN4192_	Power Cable (Length - 20 Feet)
				X	X	X	X	X	HKN6039_	Cable (Length - 17 Feet)
				X					HKN6096_	Handheld Control Head Y Cable Kit
			X					X	HLN6481_*	Systems 9000 E9 Clear Button Kit
	X				X				HLN6549_*	C4 Button Kit
	X	X	X	X		X	X	X	HLN6105_	Emergency/Secure/MPL Button Kit
		X				X			HLN6548_*	SMARTNET Button Kit
			X				X		HLN6523_*	SMARTNET Button Kit
			X					X	HLN6167_	Option Button Kit
X				X					TLN5277_	Filter Kit

X = Item Included

O = Optional item

_ = the latest version kit. When ordering a kit, refer to your specific kit for the suffix number.

* = kit not available. Order piece parts from the Customer Care and Services Division.

ASTRO Digital Spectra Plus UHF 20–40 Watt Model Chart

Model Number										Description	
D04QKH9SW3AN										Model W3 (403-433 MHz), 20-40 Watt, 512 Channels	
D04QKF9SW4AN										Model W4 (403-433 MHz), 20-40 Watt, 512 Channels	
D04QKF9SW5AN										Model W5 (403-433 MHz), 20-40 Watt, 512 Channels	
D04QKH9SW7AN										Model W7 (403-433 MHz), 20-40 Watt, 512 Channels	
T04QKH9SW9AN										Model W9 (403-433 MHz), 20-40 Watt, 512 Channels	
D04RKH9SW3AN										Model W3 (450-482 MHz), 20-40 Watt, 512 Channels	
D04RKF9SW4AN										Model W4 (450-482 MHz), 20-40 Watt, 512 Channels	
D04RKF9SW5AN										Model W5 (450-482 MHz), 20-40 Watt, 512 Channels	
D04RKH9SW7AN										Model W7 (450-482 MHz), 20-40 Watt, 512 Channels	
T04RKH9SW9AN										Model W9 (450-482 MHz), 20-40 Watt, 512 Channels	
Item No.										Description	
X	X	X	X	X						HRE6001_	Receiver F/E, Range 1
					X	X	X	X	X	HRE6003_	Receiver F/E, Range 3
X	X	X	X	X	X	X	X	X	X	HRN6020_	RF Board
X	X	X	X	X						HLE6045_	VCO Carrier, Range 1
					X	X	X	X	X	HLE6000_	VCO Carrier, Range 3
X	X	X	X	X						HLE6101_	VCO Hybrid Kit, Range 1
					X	X	X	X	X	HLE6103_	VCO Hybrid Kit, Range 3
X	X	X	X	X	X	X	X	X	X	HLN5558_	Command Board Kit
X	X	X	X	X	X	X	X	X	X	HLN6837_	VOCODER Controller
X	X	X	X	X						HLE6049_	Power Amplifier, 40W, Range 1
					X	X	X	X	X	HLE6043_	Power Amplifier, 40W, Range 3
				X					X	HLN6344_	Interface Board
	X	X	X			X	X	X		HLN6401_	Control Head Interconnect Board
X					X					HLN6459_	W3 Interface Board
X					X					HMN4044_	ASTRO Handheld Control Head (W3)
	X					X				AAHN4045_	Control Head Assembly (W4)
		X	X				X	X		HLN6396_	Control Head Deck Compatible
				X					X	HCN1078_	W9 Control Head
O	O	O	O	O	O	O	O	O	O	NTN9801_	UCM, ASTRO Spectra Plus
	X	X	X			X	X	X		HMN1080_	Microphone
				X					X	HMN1061_	Microphone
X	X	X	X	X	X	X	X	X	X	HSN4018_	Speaker
				X					X	HLN4921_	Trunnion
				X					X	HLN5488_	Installation Hardware
				X					X	HLN6185_*	Remote-Mount, SECURENET Control-Head Hardware
X	X	X	X		X	X	X	X		HLN6015_	Trunnion/Hardware (Dash Mount)
X	X	X	X		X	X	X	X		HLN6073_	Dash-Mount Hardware
X	X	X	X	X	X	X	X	X	X	HLN6418_*	Transceiver Hardware
		X					X			HLN6440_*	Control Head without Keypad Hardware
			X					X		HLN6441_*	Control Head with Keypad Hardware
				X					X	HLN6493_*	Plug Kit
				X					X	HLN4952_	Fuse Kit
X	X	X	X		X	X	X	X		HKN4191_	Power Cable (Length - 20 Feet)
				X					X	HKN4192_	Power Cable (Length - 20 Feet)
				X					X	HKN4356_	Radio Cable (Length - 17 Feet)
				X					X	HLN6481_*	Systems 9000 E9 Clear Button Kit
	X					X				HLN6549_*	C4 Button Kit

X = Item Included

O = Optional

_ = the latest version kit. When ordering a kit, refer to your specific kit for the suffix number.

* = kit not available. Order piece parts from the Customer Care and Services Division.

ASTRO Digital Spectra Plus UHF 20–40 Watt Model Chart (cont.)

Model Number										Description	
D04QKH9SW3AN										Model W3 (403-433 MHz), 20-40 Watt, 512 Channels	
D04QKF9SW4AN										Model W4 (403-433 MHz), 20-40 Watt, 512 Channels	
D04QKF9SW5AN										Model W5 (403-433 MHz), 20-40 Watt, 512 Channels	
D04QKH9SW7AN										Model W7 (403-433 MHz), 20-40 Watt, 512 Channels	
T04QKH9SW9AN										Model W9 (403-433 MHz), 20-40 Watt, 512 Channels	
D04RKH9SW3AN										Model W3 (450-482 MHz), 20-40 Watt, 512 Channels	
D04RKF9SW4AN										Model W4 (450-482 MHz), 20-40 Watt, 512 Channels	
D04RKF9SW5AN										Model W5 (450-482 MHz), 20-40 Watt, 512 Channels	
D04RKH9SW7AN										Model W7 (450-482 MHz), 20-40 Watt, 512 Channels	
T04RKH9SW9AN										Model W9 (450-482 MHz), 20-40 Watt, 512 Channels	
										Item No.	Description
	X	X	X	X		X	X	X	X	HLN6105_	Emergency/Secure/MPL Button Kit
		X					X			HLN6548_*	SMARTNET Button Kit
			X					X		HLN6523_*	SMARTNET Button Kit
				X					X	HLN6167_	Option Button Kit
X	X	X	X	X						HAE4002_	Antenna, Roof Top
					X	X	X	X	X	HAE4003_	Antenna, Quarterwave

X = Item Included

O = Optional

_ = the latest version kit. When ordering a kit, refer to your specific kit for the suffix number.

* = kit not available. Order piece parts from the Customer Care and Services Division.

ASTRO Digital Spectra Plus UHF 50–110 Watt Model Chart

Model Number										Description			
T04QLH9SW3AN										Model W3 (403-433 MHz), 50-110 Watt, 512 Channels			
T04QLF9SW4AN										Model W4 (403-433 MHz), 50-110 Watt, 512 Channels			
T04QLF9SW5AN										Model W5 (403-433 MHz), 50-110 Watt, 512 Channels			
T04QLH9SW7AN										Model W7 (403-433 MHz), 50-110 Watt, 512 Channels			
T04QLH9SW9AN										Model W9 (403-433 MHz), 50-110 Watt, 512 Channels			
T04RLH9SW3AN										Model W3 (450-482 MHz), 50-110 Watt, 512 Channels			
T04RLF9SW4AN										Model W4 (450-482 MHz), 50-110 Watt, 512 Channels			
T04RLF9SW5AN										Model W5 (450-482 MHz), 50-110 Watt, 512 Channels			
T04RLH9SW7AN										Model W7 (450-482 MHz), 50-110 Watt, 512 Channels			
T04RLH9SW9AN										Model W9 (450-482 MHz), 50-110 Watt, 512 Channels			
T04SLH9SW3AN										Model W3 (482-512 MHz), 50-110 Watt, 512 Channels			
T04SLF9SW4AN										Model W4 (482-512 MHz), 50-110 Watt, 512 Channels			
T04SLF9SW5AN										Model W5 (482-512 MHz), 50-110 Watt, 512 Channels			
T04SLH9SW7AN										Model W7 (482-512 MHz), 50-110 Watt, 512 Channels			
T04SLH9SW9AN										Model W9 (482-512 MHz), 50-110 Watt, 512 Channels			
										Item No.	Description		
X	X	X	X	X								HRE6001_	Board, RX Front-End, Range 1
					X	X	X	X	X			HRE6003_	Board, RX Front-End, Range 3
								X	X	X	X	HRE6004_	Board, RX Front-End, Range 4
X	X	X	X	X	X	X	X	X	X	X	X	HRN6020_	RF Board
X	X	X	X	X								HLE6045_	VCO Carrier, Range 1
					X	X	X	X	X			HLE6039_	VCO Carrier, Range 3
								X	X	X	X	HLE6041_	VCO Carrier, Range 4
X	X	X	X	X								HLE6101_	VCO Hybrid Kit, Range 1
					X	X	X	X	X			HLE6103_	VCO Hybrid Kit, Range 3
								X	X	X	X	HLE6104_	VCO Hybrid Kit, Range 4
X	X	X	X	X	X	X	X	X	X	X	X	HLN5558_	Command Board Kit
X	X	X	X	X	X	X	X	X	X	X	X	HLN6837_	VOCON Board Kit
X	X	X	X	X								HLE6051_	Power Amplifier Board, 100W, Range 1
					X	X	X	X	X			HLE6099_	Power Amplifier Board, Range 3
								X	X	X	X	HLE6040_	Power Amplifier Board, Range 4
	X	X	X	X	X	X	X	X	X	X	X	HLN6486_	Interconnect Board
X					X				X			HLN6574_	W3 Interconnect Board
	X	X	X		X	X	X		X	X	X	HLN6432_	Back Housing, Control Head
X					X				X			HMN4044_	W3 Handheld Control Head
	X				X				X			AAHN4045_	Control Head Assembly (W4)
		X	X			X	X			X	X	HLN6396_	W5, W7 Control Head Board
			X				X				X	HCN1078_	W9 Control Head
O	O	O	O	O	O	O	O	O	O	O	O	NTN9801_	UCM, ASTRO Spectra Plus
	X	X	X		X	X	X		X	X	X	HMN1080_	Microphone
			X				X				X	HMN1061_	Microphone
X	X	X	X	X	X	X	X	X	X	X	X	HSN6001_	Speaker
			X				X				X	HLN4921_	Control Head (W9) Trunnion
				O			O				O	HLN5488_	Radio Microphone Installation Hardware
	X	X	X		X	X	X		X	X	X	HLN6231_	Remote W4, W5, W7 Control-Head Trunnion
X	X	X	X	X	X	X	X	X	X	X	X	HLN6233_*	Option Connector Hardware
X	X	X	X	X	X	X	X	X	X	X	X	HLN6132_*	Installation Hardware, High-Power
X					X				X			HLN6291_	Installation Hardware Kit
X	X	X	X	X	X	X	X	X	X	X	X	HLN6121_*	High-Power Radio Hardware
X	X	X	X	X	X	X	X	X	X	X	X	HLN6525_*	High-Power Transceiver Hardware

X = Item Included

O = Optional

_ = the latest version kit. When ordering a kit, refer to your specific kit for the suffix number.

* = kit not available. Order piece parts from the Customer Care and Services Division.

ASTRO Digital Spectra Plus UHF 50–110 Watt Model Chart (cont.)

Model Number													Description	
T04QLH9SW3AN													Model W3 (403-433 MHz), 50-110 Watt, 512 Channels	
T04QLF9SW4AN													Model W4 (403-433 MHz), 50-110 Watt, 512 Channels	
T04QLF9SW5AN													Model W5 (403-433 MHz), 50-110 Watt, 512 Channels	
T04QLH9SW7AN													Model W7 (403-433 MHz), 50-110 Watt, 512 Channels	
T04QLH9SW9AN													Model W9 (403-433 MHz), 50-110 Watt, 512 Channels	
T04RLH9SW3AN													Model W3 (450-482 MHz), 50-110 Watt, 512 Channels	
T04RLF9SW4AN													Model W4 (450-482 MHz), 50-110 Watt, 512 Channels	
T04RLF9SW5AN													Model W5 (450-482 MHz), 50-110 Watt, 512 Channels	
T04RLH9SW7AN													Model W7 (450-482 MHz), 50-110 Watt, 512 Channels	
T04RLH9SW9AN													Model W9 (450-482 MHz), 50-110 Watt, 512 Channels	
T04SLH9SW3AN													Model W3 (482-512 MHz), 50-110 Watt, 512 Channels	
T04SLF9SW4AN													Model W4 (482-512 MHz), 50-110 Watt, 512 Channels	
T04SLF9SW5AN													Model W5 (482-512 MHz), 50-110 Watt, 512 Channels	
T04SLH9SW7AN													Model W7 (482-512 MHz), 50-110 Watt, 512 Channels	
T04SLH9SW9AN													Model W9 (482-512 MHz), 50-110 Watt, 512 Channels	
													Item No.	Description
	X						X					X	HLN6440_*	Control Head without Keypad Hardware
		X					X					X	HLN6441_*	Control Head with Keypad Hardware
			X					X				X	HLN6493_*	Plug Kit
X	X	X	X	X		X	X	X	X	X	X	X	HLN4952_	Fuse Kit
X	X	X	X	X	X	X	X	X	X	X	X	X	HKN4051_	Cable and Fuse
	X	X	X	X		X	X	X	X	X	X	X	HKN4356_	Radio Cable (Length - 17 Feet)
X	X	X	X	X	X	X	X	X	X	X	X	X	HKN6039_	Power Cable (Length - 17 Feet)
X					X					X			HKN6096_	Handheld Control Head Y Cable Kit
	X					X				X			HLN6549_*	C4 Button Kit
	X					X				X			HLN6105_	Emergency/Secure/MPL Button Kit
		X				X				X			HLN6548_*	SMARTNET Button Kit
			X				X					X	HLN6523_*	SMARTNET Button Kit
				X				X				X	HLN6481_*	Systems 9000 E9 Clear Button Kit
					X				X			X	HLN6167_	Option Button Kit
X	X	X	X	X									HAE4002_	Antenna, Roof Top
					X	X	X	X	X				HAE4003_	Antenna, Quarterwave
								X	X	X	X	X	HAE4004_	Antenna, Roof Top

X = Item Included

O = Optional

_ = the latest version kit. When ordering a kit, refer to your specific kit for the suffix number.

* = kit not available. Order piece parts from the Customer Care and Services Division.

ASTRO Digital Spectra Plus 800 MHz Model Chart

Model Number								Description	
M04UGF9SW4AN								Model W4 (800 MHz), 15 Watt, 512 Channels	
M04UGF9SW5AN								Model W5 (800 MHz), 15 Watt, 512 Channels	
M04UGH9SW7AN								Model W7 (800 MHz), 15 Watt, 512 Channels	
D04UJH9SW3AN								Model W3 (800 MHz), 35 Watt, 512 Channels	
D04UJF9SW4AN								Model W4 (800 MHz), 35 Watt, 512 Channels	
D04UJF9SW5AN								Model W5 (800 MHz), 35 Watt, 512 Channels	
D04UJH9SW7AN								Model W7 (800 MHz), 35 Watt, 512 Channels	
T04UJH9SW9AN								Model W9 (800 MHz), 35 Watt, 512 Channels	
								Item No.	Description
X	X	X	X	X	X	X	X	HRF6004_	Receiver Kit, Front-End
X	X	X	X	X	X	X	X	HRN6019_	RF Board Kit
X	X	X	X	X	X	X	X	HLF6080_	VCO Carrier
X	X	X	X	X	X	X	X	HLF6079_	VCO Hybrid
			X	X	X	X	X	HLN5558_	Command Board Kit
X	X	X						HLN6562_	Command Board, Motorcycle
X	X	X	X	X	X	X	X	HLN6837_	Vocoder/Controller
			X	X	X	X	X	HLF6077_	Power Amplifier
X	X	X						HLF6078_	15W, 800 MHz Power Amplifier
				O	O	O	X	HLN6344_	Board, Remote Mount Interconnect
X	X	X						HLN6365_	Board, Motorcycle Interconnect
			X					HLN6459_	Board, Interconnect
				X	X	X		HLN6401_	Control Head Interconnect Board
				O	O	O		HKN6432_	Back Housing Kit
			X					HMN4044_	Handheld Control Head
				X				AAHN4045_	Front Housing, W4 Control Head
X								PMLN4019_	W4 ASTRO Motorcycle Control Head
					X	X		HLN6396_	Control Head DEK-Compatible
	X	X						HLN6563_	Motorcycle Control Head
							X	HCN1078_	W9 Control Head
O	O	O	O	O	O	O	O	NTN9801	UCM
				X	X	X		HMN1080_	Microphone, Standard
							X	HMN1061_	Microphone
X	X	X						HMN1079_	Microphone, Motorcycle, Waterproof
			X	X	X	X	X	HSN4018_	Speaker
X	X	X						HSN6003_	Speaker, Motorcycle, Waterproof
X	X	X						HLN6179_	Motorcycle Adapter Control Head Speaker
			X	X	X	X		HLN6015_	Trunnion/Hardware
							X	HLN5488_	Installation Hardware (W9 Trunnion)
							X	HLN4921_	Trunnion, Control Head W9
			X	O	O	O	X	HLN6185_*	Remote-Mount, SECURENET Control Head Hardware
X	X	X	X	X	X	X	X	HLN6418_*	Transceiver Hardware
			X	X	X	X	X	HLN6126_	Mid-Power Dash Mount Radio Hardware
			X	X	X	X		HLN6073_	Radio Hardware
			X					HLN6638_	Radio Hardware
			X					HLN6613_	Transceiver Hardware
X	X	X						HLN6639_*	Radio Hardware
X	X	X						HLN6180_	Motorcycle Mounting Hardware
X	X	X						HLN6342_*	Motorcycle Hardware, Secure
				O	O	O		HLN6231_	Hardware, Remote-Mount Dash

X = Item Included

O = Optional

_ = the latest version kit. When ordering a kit, refer to your specific kit for the suffix number.

* = kit not available. Order piece parts from the Customer Care and Services Division.

ASTRO Digital Spectra Plus 800 MHz Model Chart (cont.)

Model Number							Description	
M04UGF9SW4AN							Model W4 (800 MHz), 15 Watt, 512 Channels	
M04UGF9SW5AN							Model W5 (800 MHz), 15 Watt, 512 Channels	
M04UGH9SW7AN							Model W7 (800 MHz), 15 Watt, 512 Channels	
D04UJH9SW3AN							Model W3 (800 MHz), 35 Watt, 512 Channels	
D04UJF9SW4AN							Model W4 (800 MHz), 35 Watt, 512 Channels	
D04UJF9SW5AN							Model W5 (800 MHz), 35 Watt, 512 Channels	
D04UJH9SW7AN							Model W7 (800 MHz), 35 Watt, 512 Channels	
T04UJH9SW9AN							Model W9 (800 MHz), 35 Watt, 512 Channels	
							Item No.	Description
					X		HLN6440_*	W5 Control Head without Keypad Hardware
X							HLN6444_*	Hardware, Control Head, Motorcycle
					X		HLN6441_*	W7 Control Head with Keypad Hardware
	X						HLN6445_*	Control Head, Motorcycle Hardware
			X			X	HLN6493_*	Large Black Plug Kit
						X	HLN4952_	Fuse Kit
		X	X	X	X		HKN4191_	Power Cable (Length - 20 Feet)
		O	O	O	O	X	HKN4192_	Power Cable (Length - 20 Feet)
			O	O	O	X	HKN4356_	Remote Mount Radio Cable (Length - 17 Feet)
X	X	X					HKN6062_	Cable, Control Head to Radio
X	X	X					HKN6032_	Motorcycle Power Cable
X	X	X		X	X	X	HLN6105_	Spare Button Kit
X	X	X		X	X	X	HLN6688_	Phon/Page/Emer/MPL Button
X	X	X		X	X	X	HLN6645_	Emergency/MPL Field Option Button Kit
				X			HLN6549_*	W4 Button Kit
	X			X			HLN6548_*	SMARTNET Button Kit
				X			HLN6208_	Button, Spectra SECURENET
		X			X		HLN6523_*	SMARTNET Button Kit
						X	HLN6167_	Option Button Kit
						X	HLN6481_*	Systems 9000 E9 Clear Button Kit
						X	HLN6675_*	System 9000 Button Kit Secure
				X			HLN6249_*	Button, Secure
		X			X		HLN6524_	Button, Conventional
			X	X	X	X	RRA4914_	Antenna, 1/4-Wave
X	X	X					RAF4011_	800 MHz Antenna, 3 dB Gain

X = Item Included

O = Optional

_ = the latest version kit. When ordering a kit, refer to your specific kit for the suffix number.

* = kit not available. Order piece parts from the Customer Care and Services Division.

VHF Radio Specifications

GENERAL		RECEIVER	TRANSMITTER
FCC Designations:	AZ492FT3772 AZ492FT3773	Frequency Range: Range 1: 136–162 MHz Range 2: 146–174 MHz	Frequency Range: Range 1: 136–162 MHz Range 2: 146–174 MHz
Temperature Range:	Operating: –30°C to +60°C Storage: –40°C to +85°C	Channel Spacing: 12.5 kHz, 25 kHz	Rated Output Power: Low-Power Radio: 10–25 Watt Variable Mid-Power Radio: 25–50 Watt Variable High-Power Radio: 50–110 Watt Variable
Power Supply:	12 Vdc Negative Ground Only	Input Impedance: 50 Ohm	Channel Spacing: 12.5 kHz, 25 kHz
Battery Drain: (Maximum)		Frequency Separation: Range 1: 26 MHz Range 2: 28 MHz	Channel Increment Step: 2.5 kHz
10–25 Watt Variable:		Sensitivity: (per EIA spec. RS204C)	Output Impedance: 50 Ohm
Standby @ 13.8 V:	0.8 A	20 dB Quieting: (25/30 kHz Channel Spacing)	Frequency Separation:
Receive at Rated Audio @ 13.8 V:	3.0 A	With Optional Preamp: 0.30 µV	Range 1: 26 MHz
Transmit @ Rated Power:	7.0 A	Without Optional Preamp: 0.50 µV	Range 2: 28 MHz
25–50 Watt Variable:		12 dB SINAD (25/30 kHz Channel Spacing)	Frequency Stability:
Standby @ 13.8 V:	0.8 A	With Optional Preamp: 0.20 µV	(–30 to +60°C; 25°C Ref.): ±0.00025%
Receive at Rated Audio @ 13.8 V:	3.0 A	Without Optional Preamp: 0.35 µV	Modulation Limiting:
Transmit @ Rated Power:	13.5 A	Selectivity: (per EIA Specifications)	25 kHz/30 kHz Channel Spacing: ±5.0 kHz 12.5 kHz Channel Spacing: ±2.5 kHz
50–110 Watt Variable:		(Measured in the Analog Mode)	FM Hum and Noise:
Standby @ 13.8 V:	0.9 A	25/30 kHz Channel Spacing: –80 dB	(Measured in the Analog Mode): –45 dB
Receive at Rated Audio @ 13.8 V:	4.0 A	12.5 kHz Channel Spacing: –70 dB	Emission (Conducted and Radiated): –75 dB
Transmit @ Rated Power:	27.5 A	Intermodulation: (per EIA Specifications)	Audio Sensitivity:
Dimensions (H x W x D)		(Measured in the Analog Mode)	(For 60% Max. Deviation at 1 kHz): 0.08V ±3 dB
W4, W5, and W7 Models:		With Optional Preamp: –70 dB	Audio Response:
Remote-Mount Control Head: 2.0" x 7.1" x 2.2" (50.8 mm x 180.3 mm x 55.9 mm)		Without Optional Preamp: –80 dB	(Measured in the Analog Mode) (6 dB/Octave Pre-Emphasis 300 to 3000 Hz): +1, –3 dB
Dash-Mount Radio: 2.0" x 7.1" x 8.6" (50.8 mm x 180.3 mm x 218.4 mm)		Spurious Rejection:	Emissions Designators:
W9 Model:		With Optional Preamp: –80 dB	8K10F1E, 11K0F3E, 15K0F2D, 16K0F3E, 20K0F1E, and 15K0F1D
Remote-Mount Control Head: 3.4" x 6.5" x 1.7" (86.4 mm x 165.1 mm x 43.2 mm)		Without Optional Preamp: –83 dB	AZ492FT3771: 11K0F1D, 11K0F2D AZ492FT3772: 10K0F1D, 10K0F2D AZ492FT3773: 11K0F1D, 11K0F2D
Speaker: (excluding mounting bracket)		Frequency Stability:	
5.5" x 5.5" x 2.5" (139.7 mm x 139.7 mm x 63.5 mm)		(–30° to +60°C; 25°C Reference): ±0.00025%	
Weight:		Audio Output: (per EIA Specifications)	
Mid-Power Radio: 6.1 lbs (2.8 kg)		(Measured in the Analog Mode):	
High-Power Radio: 11.2 lbs (5.1 kg)		5 Watts at Less Than 3% Distortion	
Speaker: 1.5 lbs (0.7 kg)		10 Watts Optional with Reduced Duty Cycle	
		12 Watts for High-Power Radios	

Specifications subject to change without notice.

All measurements are taken in the test mode at 25 kHz channel spacing except where indicated.

UHF Radio Specifications

GENERAL		RECEIVER		TRANSMITTER	
FCC Designations:	AZ492FT4786 AZ492FT4787	Frequency Range:		Frequency Range:	
Temperature Range:		Range 1:	403–433 MHz	Range 1:	403–433 MHz
Operating:	–30°C to +60°C	Range 2:	438–470 MHz	Range 2:	438–470 MHz
Storage:	–40°C to +85°C	Range 3:	450–482 MHz	Range 3:	450–482 MHz
Power Supply:	12 Vdc Negative Ground Only	Range 4:	482–512 MHz	Range 4:	482–512 MHz
Battery Drain: (Maximum)		Channel Spacing:	12.5 kHz or 25 kHz	Rated Output Power:	
1–6 Watt Variable:		Input Impedance:	50 Ohm	Low-Power Radio:	1–6 Watt Variable
Standby @ 13.8 V:	0.7 A	Frequency Separation:		Mid-Power Radio:	10–25 Watt Variable
Receive at Rated Audio @ 13.8 V:	3.0 A	Range 1 and 4:	30 MHz	20–40 Watt Variable	
Transmit @ Rated Power:	4.0 A	Range 2 and 3:	32 MHz	High-Power Radio:	50–110* Watt Variable
10–25 Watt Variable:		Sensitivity: (per EIA spec. RS204C)		Channel Spacing:	12.5 kHz or 25 kHz
Standby @ 13.8 V:	0.7 A	20 dB Quieting: (25 kHz Channel Spacing)		Output Impedance:	50 Ohm
Receive at Rated Audio @ 13.8 V:	3.0 A	With Optional Preamp:	0.30 µV	Frequency Separation:	
Transmit @ Rated Power:	7.0 A	Without Optional Preamp:	0.50 µV	Range 1 and 4:	30 MHz
20–40 Watt Variable:		12 dB SINAD (25 kHz Channel Spacing)		Range 2 and 3:	32 MHz
(30 W Max. in Talk-Around Mode)		With Optional Preamp:	0.20 µV	Frequency Stability:	
Standby @ 13.8 V:	0.7 A	Without Optional Preamp:	0.35 µV	(–30° to +60°C; 25°C Ref.):	±0.00025%
Receive at Rated Audio @ 13.8 V:	3.0 A	Selectivity: (per EIA Specifications)		Modulation Limiting:	
Transmit @ Rated Power:	13.0 A	(Measured in the Analog Mode)		25 kHz Channel Spacing:	±5.0 kHz
78 Watt (Range 3 & 4)/110 W (Range 1 & 3):		25 kHz Channel Spacing:	–75 dB	12.5 kHz Channel Spacing:	±2.5 kHz
Standby @ 13.8 V:	0.8 A	12.5 kHz Channel Spacing:	–70 dB	FM Hum and Noise:	
Receive at Rated Audio @ 13.8 V:	4.0 A	Intermodulation: (per EIA Specifications)		(Measured in the Analog Mode):	–45 dB
Transmit @ Rated Power:	31.5 A	(Measured in the Analog Mode)		Emission (Conducted and Radiated):	–70 dB
Dimensions (H x W x D)		With Optional Preamp:	–70 dB	Audio Sensitivity:	
W4, W5, and W7 Models:		Without Optional Preamp:	–75 dB	(For 60% Max. Deviation at 1 kHz):	0.08V ±3 dB
Remote-Mount Control Head:	2.0" x 7.1" x 2.2" (50.8 mm x 180.3 mm x 55.9 mm)	Spurious Rejection:		Audio Response:	
Dash-Mount Radio:	2.0" x 7.1" x 8.6" (50.8 mm x 180.3 mm x 218.4 mm)	With Optional Preamp:	–80 dB	(Measured in the Analog Mode)	
W9 Model:		Without Optional Preamp:	–83 dB	(6 dB/Octave Pre-Emphasis 300 to 3000Hz):	+1, –3 dB
Remote-Mount Control Head:	3.4" x 6.5" x 1.7" (86.4 mm x 165.1 mm x 43.2 mm)	Frequency Stability:		Emissions Designators:	
Speaker: (excluding mounting bracket)	5.5" x 5.5" x 2.5" (139.7 mm x 139.7 mm x 63.5 mm)	(–30° to +60°C; 25°C Reference):	±0.00025%	8K10F1E, 11K0F3E, 15K0F2D, 16K0F3E, 20K0F1E, 15K0F1D, 11K0F1D, and 11K0F2D	
Weight:		Audio Output: (per EIA Specifications)			
Mid-Power Radio:	6.1 lbs (2.8 kg)	(Measured in the Analog Mode):			
High-Power Radio:	11.2 lbs (5.1 kg)	5 Watts at Less Than 3% Distortion			
Speaker:	1.5 lbs (0.7 kg)	10 Watts Optional with Reduced Duty Cycle			
		12 Watts for High-Power Radios			

Specifications subject to change without notice.

All measurements are taken in the test mode at 25 kHz channel spacing except where indicated.

* Maximum power 78 Watts above 470 MHz.

800 MHz Radio Specifications

GENERAL		RECEIVER	TRANSMITTER
FCC Designations:	AZ492FT5759 AZ492FT5751	Frequency Range: 851–869 MHz	Frequency Range: Repeater Mode: 806–824 MHz Talk-Around Mode: 851–869 MHz
Temperature Range:		Channel Spacing: 12.5 kHz/20 kHz/25 kHz	
Operating:	–30°C to +60°C	Input Impedance: 50 Ohm	Rated Output Power:
Storage:	–40°C to +85°C	Frequency Separation: 18 MHz	Mid-Power Radio: 15 Watt High-Power Radio: 35 Watt
Power Supply:	12 Vdc Negative Ground Only	Sensitivity: (per EIA spec. RS204C)	Channel Spacing: 12.5 kHz/20 kHz/25 kHz
Battery Drain: (Maximum)		20 dB Quieting: (25 kHz Channel Spacing): 0.50µV	Output Impedance: 50 Ohm
15 Watt:		12 dB SINAD: (25 kHz Channel Spacing): 0.35µV	Frequency Separation: 18 MHz
Standby @ 13.8 V:	0.7 A	Digital Sensitivity:	Frequency Stability:
Receive at Rated Audio @ 13.8 V:	3.0 A	1% BER (12.5 kHz channel): 0.30µV	(–30° to +60°C; 25°C Ref.): ±0.00015%
Transmit @ Rated Power:	6.5 A	5% BER (12.5 kHz channel): 0.25µV	Modulation Limiting:
35 Watt: (30 W max. in Talk-Around mode)		Selectivity: (per EIA Specifications)	25 kHz Channel Spacing: ±5.0 kHz
Standby @ 13.8 V:	0.7 A	(Measured in the Analog Mode)	Modulation Fidelity (C4FM):
Receive at Rated Audio @ 13.8 V:	3.0 A	25 kHz Channel Spacing: –75 dB	12.5 kHz Digital Channel: ±2.8 kHz
Transmit @ Rated Power:	14.0 A	Intermodulation: (per EIA Specifications)	FM Hum and Noise:
Dimensions (H x W x D)		(Measured in the Analog Mode): –75 dB	(Measured in the Analog Mode): –40 dB
W4, W5, and W7 Models:		Spurious Rejection: –90 dB	Emission (Conducted and Radiated): –60 dBc
Remote-Mount Control Head:	2.0" x 7.1"x 2.2" (50.8 mm x 180.3 mm x 55.9 mm)	Frequency Stability:	Audio Sensitivity:
Dash-Mount Radio:	2.0" x 7.1"x 8.6" (50.8 mm x 180.3 mm x 218.4 mm)	(–30° to +60°C; 25°C Reference): ±0.00015%	(For 60% Max. Deviation at 1 kHz): 0.08V ±3 dB
W9 Model:		Audio Output: (per EIA Specifications)	Audio Response:
Remote-Mount Control Head:	3.4" x 6.5"x 1.7" (86.4 mm x 165.1 mm x 43.2 mm)	(Measured in the Analog Mode): 5 Watts at Less Than 3% Distortion 10 Watts Optional with Reduced Duty Cycle 12 Watts for High-Power Radios	(Measured in the Analog Mode) (6 dB/Octave Pre-Emphasis 300 to 3000Hz): +1,–3 dB
Speaker: (excluding mounting bracket)	5.5" x 5.5"x 2.5" (139.7 mm x 139.7 mm x 63.5 mm)		Emissions Designators:
Weight:			8K10F1E, 15K0F1D, 10K0F2D, 11K0F3E, 15K0F2D, 10K0F1D, 16K0F3E, and 20K0F1E
Mid-Power Radio:	6.1 lbs (2.8 kg)		
High-Power Radio:	11.2 lbs (5.1 kg)		
Speaker:	1.5 lbs (0.7 kg)		

Specifications subject to change without notice.
All measurements are taken in the test mode at 25 kHz channel spacing except where indicated.

Notes

Chapter 1 Introduction

1.1 General

This manual includes all the information necessary to maintain peak product performance and maximum working time. This detailed level of service (component-level) is typical of some service centers, self-maintained customers, and distributors.

Use this manual in conjunction with the *ASTRO Digital Spectra and Digital Spectra Plus Mobile Radios Basic Service Manual* (Motorola part number 6881076C20), which helps in troubleshooting a problem to a particular board.

Conduct the basic performance checks first to verify the need to analyze the radio and help pinpoint the functional problem area. In addition, you will become familiar with the radio test mode of operation which is a helpful tool. If any basic receiver or transmitter parameters fail to be met, the radio should be aligned using the radio alignment procedure described in the *ASTRO Digital Spectra and Digital Spectra Plus Mobile Radios Basic Service Manual*.

Included in other areas of this manual are functional block diagrams, detailed Theory of Operation, troubleshooting charts and waveforms, schematics, and parts list. You should be familiar with these sections to aid in deducing the problem circuit. Also included are component location diagrams to aid in locating individual circuit components, as well as IC diagrams, which identify some convenient probe points.

The Theory of Operation section of this manual contains detailed descriptions of operations of many circuits. Once you locate the problem area, review the Troubleshooting Chart for that circuit to fix the problem.

1.2 Notations Used in This Manual

Throughout the text in this publication, you will notice the use of warnings, cautions, and notes. These notations are used to emphasize that safety hazards exist, and care must be taken and observed.

NOTE: An operational procedure, practice, or condition that is essential to emphasize.



Caution

CAUTION indicates a potentially hazardous situation which, if not avoided, might result in equipment damage.



WARNING

WARNING indicates a potentially hazardous situation which, if not avoided, could result in death or injury.



DANGER

DANGER indicates an imminently hazardous situation which, if not avoided, will result in death or injury.

You will also find in this publication the use of the asterisk symbol (*) to indicate a negative or NOT logic true signal.

Chapter 2 General Overview

2.1 Introduction

The ASTRO Digital Spectra radio is a dual-mode (trunked/conventional), microcontroller-based transceiver incorporating a Digital Signal Processor (DSP). The microcontroller handles the general radio control, monitors status, and processes commands input from the keypad or other user controls. The DSP processes the typical analog signals and generates the standard signaling digitally to provide compatibility with existing analog systems. In addition it provides for digital modulation techniques utilizing voice encoding techniques with error correction schemes to provide the user with enhanced range and audio quality all in a reduced bandwidth channel requirement. It allows embedded signaling which can mix system information and data with digital voice to add the capability of supporting a multitude of system features.

The ASTRO Digital Spectra radio comes in five models and are available in the following bands: VHF (136-174 MHz), UHF (403-470 MHz or 450-512 MHz), and 800 MHz (806-870 MHz).

The ASTRO Digital Spectra radio comprises seven major assemblies, six of which are in the main radio housing. They are:

- Control-Head Assembly (Dash- or Remote-Mount) — is connected, directly or remotely, to the front of the transceiver by the interconnect board or remote interconnect board and control cable. This assembly contains a vacuum fluorescent (VF) display, VF driver, microprocessor and serial bus interface.
 - Power Amplifier (PA) — contains antenna switch, directional coupler/detector, and amplifier(s).
 - Front-End Receiver Assembly — contains pre-amplifier, preselector, mixer, and injection filter.
 - RF Board — contains receiver I-F amplifier, demodulator, synthesizer logic and filtering circuitry, and digital receiver back-end integrated circuit (IC).
 - VCO/Buffer/Divider Board — contains voltage controlled oscillator (VCO), divider, receive and transmit buffers.
 - Command Board — contains power control/regulator, digital-to-analog (D/A) IC, serial bus interface, and audio power amplifier (PA).
 - VOCON (Vocoder/Controller) Board — contains the microcomputer unit (MCU), its associated memory and memory management integrated circuit, and the digital signal processor (DSP) and its associated memories and support IC.
 - VOCON Plus (Vocoder/Controller) Board — the architecture is based on a Dual-Core processor, which contains a DSP Core, an MCORE 210 Microcontroller Core, and custom peripherals. The board also contains memory ICs and DSP support ICs.
-

2.2 Analog Mode of Operation

When the radio is receiving, the signal comes from the antenna/antenna-switch on the power amplifier board to the front-end receiver assembly. The signal is then filtered, amplified, and mixed with the first local-oscillator signal generated by the voltage-controlled oscillator (VCO). The resulting intermediate frequency (IF) signal is fed to the IF circuitry on the RF board, where it is again filtered and amplified. This amplified signal is passed to the digital back-end IC, where it is mixed with the second local oscillator to create the second IF at 450 kHz. The analog IF is processed by an analog-to-digital (A/D) converter, where it is converted to a digital bit stream and divided down to a baseband signal, producing digital samples. These samples are converted to current signals and sent to the DSP support IC. The digital-signal-processor-support IC digitally filters and discriminates the signal, and passes it to the digital-signal processor (DSP). The DSP decodes the information in the signal and identifies the appropriate destination for it. For a voice signal, the DSP will route the digital voice data to the DSP-support IC for conversion to an analog signal. The DSP-support IC will then present the signal to the audio power amplifier on the command board, which drives the speaker. For signalling information, the DSP will decode the message and pass it to the microcomputer.

When the radio is transmitting, microphone audio is passed to the command board limiter then to the DSP-support IC, where the signal is digitized. The DSP-support IC passes digital data to the DSP, where pre-emphasis and low-pass (splatter) filtering are done. The DSP returns this signal to the DSP-support IC, where it is reconverted into an analog signal and scaled for application to the voltage-controlled oscillator as a modulation signal. Transmitted signalling information is accepted by the DSP from the microcomputer, coded appropriately, and passed to the DSP-support IC, which handles it the same as a voice signal. Modulation information is passed to the synthesizer along the modulation line. A modulated carrier is provided to the power amplifier (PA) board, which transmits the signal under dynamic power control.

2.3 ASTRO Mode of Operation

In the ASTRO mode (digital mode) of operation, the transmitted or received signal is limited to a discrete set of deviation levels, instead of continuously varying. The receiver handles an ASTRO-mode signal identically to an analog-mode signal up to the point where the DSP decodes the received data. In the ASTRO receive mode, the DSP uses a specifically defined algorithm to recover information. In the ASTRO transmit mode, microphone audio is processed identically to an analog mode with the exception of the algorithm the DSP uses to encode the information. This algorithm will result in deviation levels that are limited to discrete levels.

2.4 Control Head Assembly

This section discusses the basic operation and components of each control head assembly.

2.4.1 Display (W3 Model)

The control head assembly for a W3 model has a two-line, 14-character liquid-crystal display (LCD) with eight Status annunciators.

2.4.2 Display (W4, W5, and W7 Models)

The control head assembly for W4, W5, and W7 models has an 8-character, alphanumeric, vacuum fluorescent display. The anodes and the grids operate at approximately 34 Vdc when on and 0 Vdc when off. The filament operates at approximately 2.4 Vac. The voltage for the display is generated by a fixed-frequency, variable duty-cycle controlled "flyback" voltage converter. The switching frequency is approximately 210 kHz. The internal microprocessor controls the voltage converter, which provides approximately 37 Vdc to the vacuum fluorescent (VF) driver and approximately 2.4 Vrms to the VF display.

2.4.3 Display (W9 Model)

The control-head assembly for a W9 model has an 11-character, alphanumeric, vacuum fluorescent display. It needs three separate voltages to operate; the cathode needs 35 V to accelerate electrons to the anode; the grid needs 40 V to totally shut off current flow; the filament needs 3.8 Vac at 80mA. These voltages are obtained from the transformer on the display controller board.

2.4.4 Vacuum Fluorescent Display Driver

This Vacuum Fluorescent (VF) display driver receives ASCII data from the VOCON board, decodes it into display data, and then scans the display with the data. Once properly loaded into the display, data is refreshed without any further processor action. The display driver is periodically reset by the actions of transistors that watch the clock line from the microprocessor to the display driver. When the clock line is held low for more than 600 ms, the display driver resets and new display data follows.

2.4.5 Vacuum Fluorescent Voltage Source (W9 Model)

Voltage for the VF display is generated by a fixed frequency, variable-duty cycle driven, flyback voltage converter. An emitter-coupled stable multi vibrator runs at approximately 150 kHz. The square wave output from this circuit is integrated to form a triangle that is applied to the non-inverting input of half an integrated circuit (IC).

During start up, the inverting input is biased at 3.7 V. A transistor is on while the non-inverting input voltage is below 3.7 V. This allows current to flow in a transformer, building a magnetic field. When the triangle wave exceeds 3.7 V, the transistor turns off and the magnetic field collapses, inducing negative current in the transformer.

This current flow charges two capacitors. As the voltage on one of the capacitor increases beyond 35 V, a diode begins to conduct, pulling the integrated circuit's inverting input below 3.7 V. This decreases the cycle time to produce the 35 V. The 41 V supply is not regulated, but it tracks the 35 V supply.

Similarly, the ac supply for VF filament is not regulated, but is controlled to within one volt by an inductor on the display board.

2.4.6 Controls and Indicators

The control-head assembly processes all the keypad (button) inputs and visual indicators through the microprocessor. Some of the buttons double as function keys for radio options. All buttons are backlit to allow operation in low-light conditions.

2.4.7 Status LEDs

These LEDs are driven by the display driver as though they were decimal points on the VF display. Level shifting transistors are required for this since the display driver uses 39 V for control signals.

2.4.8 Backlight LEDs

The microprocessor operates the backlight LEDs. A transistor supplies base current to the individual LED driver transistors. The driver transistors act as constant current sources to the LEDs. Some backlight LEDs are connected to a thermistor. This circuit allows more current to flow through these LEDs at room temperature and reduces current as the temperature rises.

2.4.9 Vehicle Interface Ports

The Vehicle Interface Ports (VIPs) allow the control head to activate external circuits and receive inputs from the outside world. In general, VIP outputs are used for relay control and VIP inputs accept inputs from external switches. See the cable kit section for typical connections of VIP input switches and VIP output relays.

The VIP outputs are driven by logic within the control head for both the Dash and Remote Mount configuration. Field programming of the radio can define the functions of these pins. The output transistors that drive the VIP outputs can sink 300 mA of current. Primarily, they are used to control external relays. These relays should be connected between the respective VIP output pin and switched B+. Typical applications for VIP outputs are controlling the external horn/lights alarm and activating the horn-ring transfer relay function.

Remote Mount Configuration:

The VIP pins are located on the back of the control head below the area labeled "VIP". For Remote Mount radios, all three VIP inputs and outputs are available at the rear of the control head. The VIP inputs are connected to ground with either normally-open or normally-closed switches.

Dash Mount Configuration:

For the Dash Mount configuration, only two VIP output pins are available and they are located at the 15-pin accessory connector. VIP input lines are not available in this configuration.

2.4.10 Power Supplies

The +5-V supply is a three-terminal regulator IC to regulate the 12 V SWB+ down for the digital logic hardware.

2.4.11 Ignition Sense Circuits

A transistor senses the vehicle ignition's state, disabling the radio when the ignition is off. For negative-ground systems, the orange lead is typically connected to the fuse box (+12 V).

NOTE: Refer to the *ASTRO Spectra and Digital Spectra FM Two-Way Mobile Radios Installation Manual* (6881070C85) for more information on operating the radio independent of the ignition switch.

2.5 Power Amplifier

The power amplifier (PA) is a multi-stage, discrete-transistor RF amplifier consisting of the following:

- Low-level power controlling stage
- Drivers
- Final amplifier
- Directional coupler
- Antenna switch
- Harmonic filter

2.5.1 Gain Stages

The first stage buffers the RF signal, filters harmonics, and acts as a variable amplifier. All of the amplifying stages are matched using transmission lines, capacitors, and inductors and are supplied with DC from either A+, keyed 9.4-V, or 9.6-V sources. Following the last gain stage, PIN diodes switch the signal flow either from the antenna to the receiver, or from the last gain stage to the antenna.

2.5.2 Power Control

A directional coupler and detector network controls power. It senses the forward power from the last gain stage and feeds the detected voltage back to the command board control circuitry where it is compared to a reference voltage set during power-set procedures. The DC feed voltage is corrected and supplied to the “controlled” stage of the power amplifier. Circuitry on the power amplifier board controls the gain of the first stage and is proportional to the DC control voltage.

2.5.3 Circuit Protection

Current and temperature sensing circuitry on the power amplifier board feed sensed voltages to the command board for comparison. If the command board suspects a fault condition, it overrides the power control function and cuts the power back to a level that is safe for the conditions. In addition, some high-power amplifier boards include circuitry that monitors the power supply line. If the battery voltage exceeds or drops below a pre-determined level, the power output of the amplifier is adjusted to ensure proper operation of the transmitter.

2.5.4 DC Interconnect

The ribbon cable connector carries sensed voltages for power and protection to the command board. It also carries A+ feed to the command board for distribution throughout the internal transceiver housing and carries control voltage from the command board to the power amplifier board.

The rear battery connector carries A+ from the battery to the power amplifier board. The red lead goes directly to the A+ terminal on the PA board. The black lead from the battery connector ties to the chassis, and connection to the power amplifier board is made through the board mounting screws.

A+ ground connection for the internal transceiver housing is through the RF coax ground connectors and through the mechanical connection of the power amplifier heatsink to the rest of the radio. During test conditions in which the power amplifier assembly (board and heatsink) is physically disconnected from the rest of the radio, it is acceptable to rely on the coax cable connections to carry ground to the internal housing.

2.6 Front-End Receiver Assembly

The receiver front-end consists of a preselector, a mixer circuit, and an injection filter. The receiver injection (1st local oscillator) comes from the VCO assembly through a coax cable. The injection filter is either fixed-tuned or tuned at the factory depending upon the bandsplit. The output of the filter is connected to the mixer.

The preselector is a fixed-tuned filter. The receiver signal is fed to the preselector from the antenna switch in the PA for the 800 MHz and UHF radios, or the preamp output for VHF. The signal is then sent to the mixer integrated circuit where it is connected to the mixer transistor. The receiver injection is also fed to this point. The mixer output is at the 1st IF center frequency of 109.65 MHz. This signal is sent to the 1st IF amplifier stage on the RF board through a coaxial cable.

2.7 RF Board Basic

The RF board contains the common synthesizer circuits, dual IF receiver and demodulation circuits. A 4-pole crystal filter at 109.65 MHz provides first IF selectivity. (For HRN6014D, HRN6020C, HRN6019C, HRN4009D, HRN4010C and later RF board kits, two 2-pole crystal filters provide first IF selectivity at 109.65 MHz.) The output of the filter circuit is fed directly to the custom digital back-end circuit module. An amplification circuit at 109.65 MHz, the second mixer, the second IF amplifiers (at 450 kHz), the IF digital-to-analog converter, and the baseband down-converter comprise the digital back-end circuit module.

Synthesizing for the first and second VCO is performed by the prescaler and synthesizer ICs. These ICs are programmed through a serial data bus from signals generated on the VOCON board. A DC voltage generated on the command board, sets the synthesizer's reference oscillator frequency of 16.8 MHz. This voltage is controlled by the digital-to-analog converter (D/A), and is the only element of the RF board requiring alignment.

The second local oscillator runs at 109.2 MHz (low-side injection), or 110.1 MHz (high-side injection) and consists of a VCO which is frequency-locked to the reference oscillator. Part of the local oscillator's circuitry is in the prescaler IC.

A clamp and rectifier circuit on the RF board generates a negative DC voltage of -4 V (nominal) for increasing the total voltage available to the first VCO and second local oscillator's VCO. The circuit receives a 300 kHz square wave output from the prescaler IC, then clamps, rectifies, and filters the signal for use as the negative steering line for the two VCOs.

2.8 Voltage-Controlled Oscillator

This section discusses the voltage-controlled oscillator components and basic operation for each band.

2.8.1 VHF Radios

The voltage-controlled oscillator (VCO) assembly utilizes a common-gate Field Effect Transistor (FET) in a Colpitts configuration as the gain device. The LC tank circuit's capacitive portion consists of a varactor bank and a laser-trimmed stub capacitor. The inductive portion consists of microstrip transmission line resonators. The stub capacitor serves to tune out build variations. Tuning is performed at the factory and is not field adjustable. The varactor network changes the oscillator frequency when the DC voltage of the steering line changes. The microstrip transmission lines are shifted in and out of the tank by PIN diodes for coarse frequency jumps. A third varactor is used in a modulation circuit to modulate the oscillator during transmit.

The VCO output is coupled to a transistor for amplification and for impedance buffering. The output of this stage passes through a low-pass filter where the signal is split into three paths. One path feeds back to the synthesizer prescaler; the other two provide injection for the RX and TX amplification strings. The receive injection signal is further amplified and passed to the RX front-end injection filter. The transmit signal goes to an analog divider, which divides the signal by two. The signal is amplified and buffered and then injected into the transmitter's low-level amplifier.

All transmit circuitry operates from keyed 9.4 V to conserve current drain while the radio is receiving. A transistor/resistor network drives the PIN diodes in the VCO tank. These driver networks provide forward bias current to turn diodes on and reverse the bias voltage to turn the diodes off. AUX 1 AND AUX 2 lines control the PIN diode driver networks.

2.8.2 UHF and 800 MHz Radios

The voltage-controlled oscillator (VCO) assembly generates variable frequency output signals controlled by the two steering lines. The negative steering line increases the tuning range of the VCO, while the positive steering line affects the synthesizer control loop to incrementally change the frequency.

The VCO generates a signal in the required frequency range. For UHF and 800 MHz radios, this signal is fed to the doubler/buffer circuit which, in turn, doubles the VCO output frequency and amplifies it to the power level required by the TX buffer and RX mixer. A PIN diode switch routes the signal to the TX port when the keyed 9.4 V is high. Otherwise, the signal is routed to the RX port. The synthesizer feedback is provided from the output of the doubler stage.

2.9 Command Board

The serial input/output IC provides command board functions including buffers for PTT, channel active, squelch mute, busy, and data transmission, and logic functions for switched B+, emergency, reset, and power control.

The regulator and power control circuits include an unswitched +5 V discrete circuit and the regulator/power control IC, which produces both switched +5 V and 9.6 V. The unswitched +5 V source is used as a reference for its switched +5 V source. Filtered unswitched +5 V is used for the microcontrol circuits. Switched +5 V and 9.6 V are controlled by a digital transistor from the serial input/output IC. The power control circuitry receives power set and limit inputs from the digital-to-analog IC, and feedback from the RF power amplifier. Based on those inputs, the power control circuitry produces a control voltage to maintain a constant RF power level to the antenna.

The reset circuits consist of the power-on reset, high/low battery voltage reset, and the external bus system reset. The reset circuits allow the microcomputer to recover from an unstable situation; for example, no battery on the radio, battery voltage too high or too low, and remote devices on the external bus not communicating. Communication in RS-232 protocol is provided by an IC which interfaces to the rear accessory connector (J2).

2.10 ASTRO Spectra Vocoder/Controller Board

The Vocoder/Controller (VOCON) board, located on the top side of the radio housing, contains a microcontrol unit (MCU) with its flash memory, DSP, and DSP support ICs. The VOCON board controls receive/transmit frequencies, the display, and various radio functions, using either direct logic control or serial communication to external devices. The connector J801 provides interface between the encryption module and the VOCON board for encrypting voice messages.

The VOCON board executes a stored program located in the FLASH ROM. Data is transferred to and from memory by the microcontrol unit data bus. The memory location from which data is read, or to which data is written, is selected by the address lines.

The support-logic IC acts as an extension of the microcontrol unit by providing logic functions such as lower address latch, reset, memory address decoding, and additional control lines for the radio. The VOCON board controls a crystal-pull circuit to adjust the crystal oscillator frequency on the microcontrol unit, so that the E-clock harmonics do not cause interference with the receive channel.

The vocoder circuitry on the VOCON board is powered by a switched +5-V regulator located on the command board. This voltage is removed from the board when the radio is turned off by the control head switch.

The DSP (digital-signal processing) IC performs signaling, voice encoding/decoding, audio filtering, and volume control functions. This IC performs Private-Line/Digital Private Line (PL/DPL) encode and alert-tone generation. The DSP IC transmits pre-emphasized analog signals and applies a low-pass (splatter) filter to all transmitted signals. It requires a 33 MHz crystal to function. An 8 kHz interrupt signal generated by the DSP-support IC is also required for functionality. This device is programmed using parallel programming from the microcontrol unit and the DSP-support IC.

The DSP-support IC performs analog-to-digital and digital-to-analog conversions on audio signals. It contains attenuators for volume, squelch, deviation, and compensation, and it executes receiver filtering and discrimination. The IC requires a 2.4 MHz clock to function (generated by the digital back-end IC) and is programmed by the microcontrol unit's Serial Peripheral Interface (SPI) bus.

2.11 Radio Power

This section provides information on DC power distribution in ASTRO radios.

2.11.1 General

In the ASTRO radio, power is distributed to seven boards: command, VOCON, control head, synthesizer, receiver front end, RF, and RF power amplifier.

Power for the radio is supplied by the vehicle's 12-V battery. When using a desktop adapter unit, an external DC power supply can be connected to replace the vehicle's battery source.

A+ (referred to as incoming unswitched battery voltage) enters the radio through the rear RF power amplifier connector (P1) and is the main entry for DC power. The second path, through P2, pin 5, provides ignition sense to inhibit the RF transmitter when the ignition switch is off.

When the command board regulators are “on,” the 9.6-V output sources the command board and RF board circuits. The switched +5 V is routed to the VOCON board. See [Figure 2-1](#).

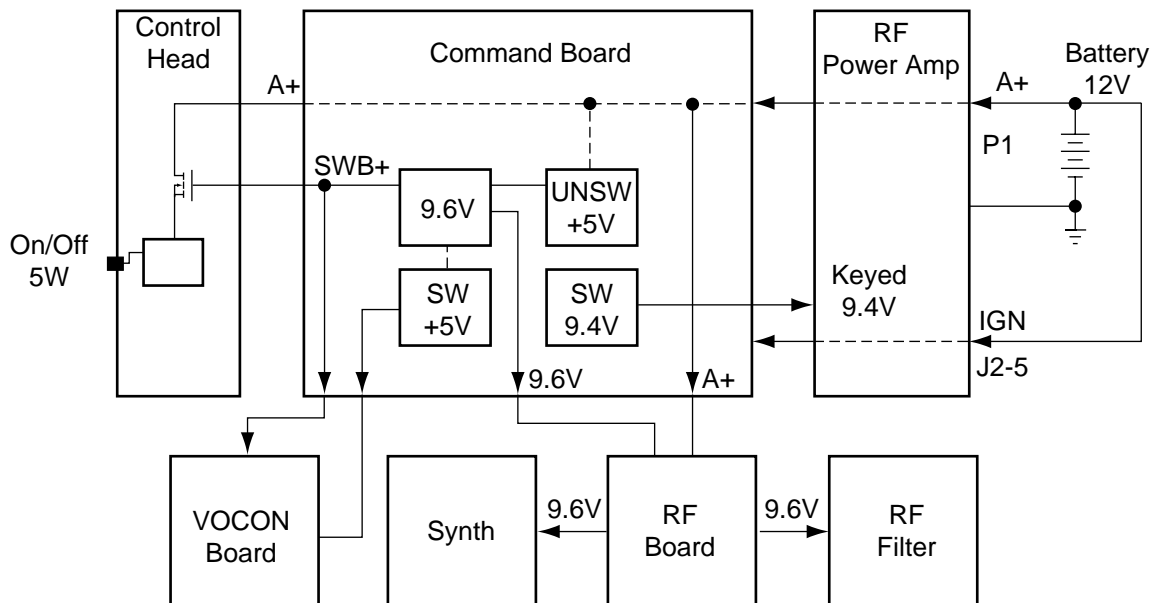

Figure 2-1. DC Voltage Routing Block Diagram

The 9.6 V and the A+ voltage are the main DC power for the RF board. Outputs from the RF board provide DC power to the synthesizer and the receiver front-end filter. The RF board has an internal +5-Vdc regulator that is sourced from the A+ voltage.

The voltage to power the 9.4-V regulator is produced by the command board's 9.6-V regulator. The 9.4 V (referred to as “keyed 9.4 V”) is controlled by the VOCON board through P501, pin 45. This DC voltage enables the transmitter's RF power amplifier when the VOCON board senses a lock detect from the synthesizer.

2.11.2 B+ Routing for ASTRO Spectra VOCON Board

Refer to Section 3.4, “ASTRO Spectra Plus VOCON Board,” on page 3-38 for information on the ASTRO Spectra Plus.

See [Figure 2-2](#) on page 2-10 and your specific schematic diagram.

The A+ power for the radio is derived from the 12-V battery, which is applied to the command board through connector P503, pins 5 and 9. This A+ voltage is routed through the command board to the control head connector, P502, pin 30 and to the VOCON board, J501, pin 38.

The interconnect board couples the A+ voltage from the command board to the control head, where a power FET (Q51) provides the means of controlling the main power source (SWB+) by the on/off switch. SWB+ is routed back to the SIO/IC (U522) on the command board through connector P502. The SIO/IC controls the RPCIC enable line.

When the RPCIC enable line toggles low, the 9.6-V and the SW+5-V regulators turn on. The SW+5-V regulator is the main power source for the VOCON board. Digital and analog +5 V are derived by filtering SW+5 V through .005 μ H chokes L511 and L510 on the command board. These two 5-V regulated supplies are used to partition the digital logic circuitry from the analog circuitry.

Transistor Q206 controls solid-state power switch Q207, providing SWB+ to the encryption module (if equipped). The "SWB+" and "UNSWB+" encryption voltages both originate from pin 38 of J501 and are fed to the encryption module via J801.

Port PL3 (5-V EN) on the SLIC and Q207 are under the control of the microcontroller unit (MCU), U204. This allows the MCU to follow an orderly power-down sequence when it senses that the B+ sense is off. This sense is provided via resistor network R222 and R223, which provides an input to the A/D port to the MCU.

It should also be noted that a system reset is provided by the undervoltage detector, U407. This device brings the system out of reset on power-up, and provides a system reset to the microcomputer on power-down.

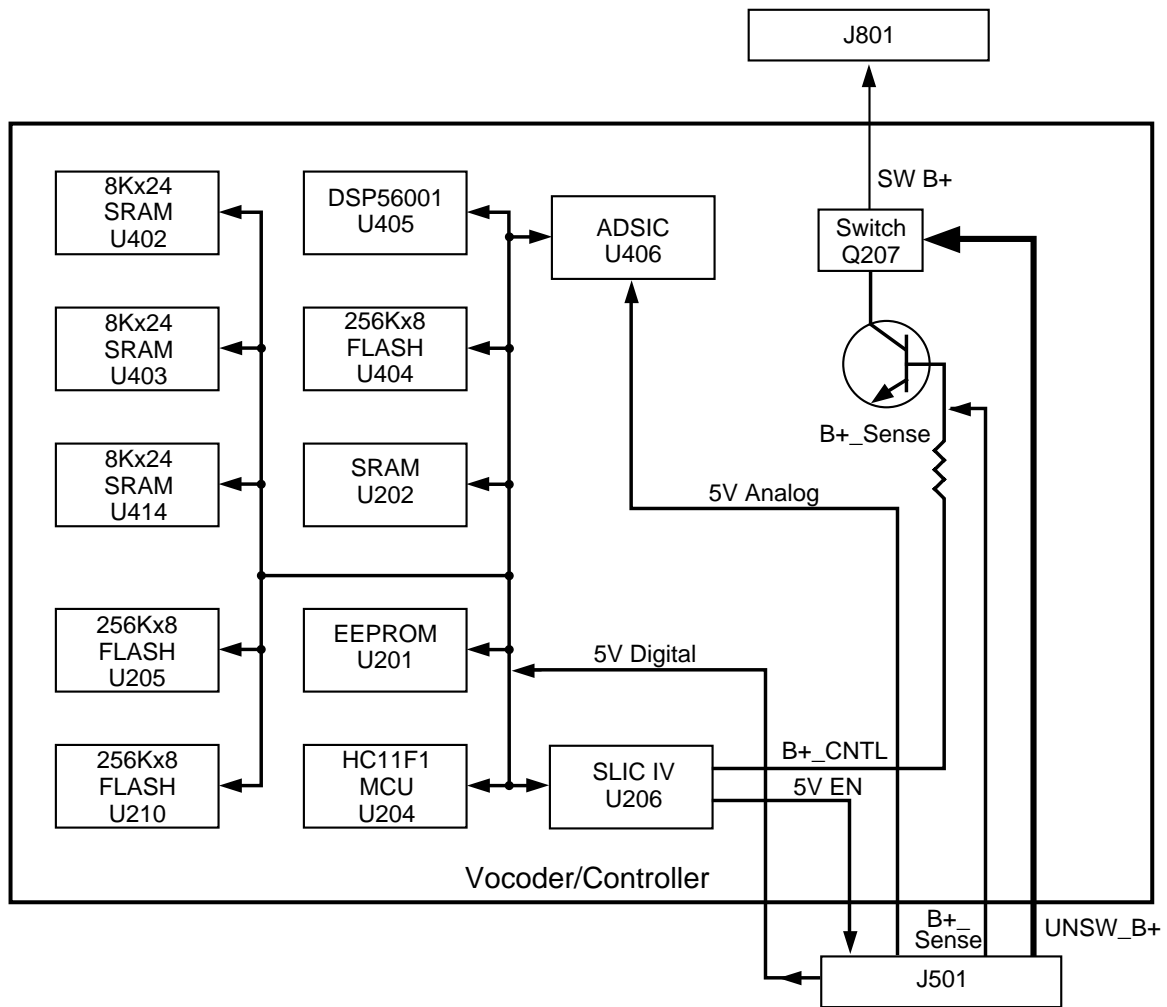

MAEPF-25104-O

Figure 2-2. ASTRO Spectra B+ Routing for Vocoder/Controller (VOCON) Board

Chapter 3 Theory of Operation

3.1 RF Board

This section provides a detailed circuit description of the ASTRO RF board for VHF, UHF, and 800 MHz models. This board contains the common synthesizer circuits (synthesizer section) and dual IF receiver and demodulation circuits (receiver back-end). When reading the theory of operation, refer to your appropriate schematic and component location diagrams located in “[Chapter 7. Schematics, Component Location Diagrams and Parts Lists](#)”. This detailed Theory of Operation will help isolate the problem. However, first use the *ASTRO Digital Spectra and Digital Spectra Plus Mobile Radios Basic Service Manual* (6881076C20) to troubleshoot the problem to a particular board.

3.1.1 General

The synthesizer section includes the prescaler IC (U601), the synthesizer IC (U602), and the reference oscillator (U600). The prescaler and the synthesizer chips are completely controlled by the serial data bus.

The prescaler IC (see [Figure 3-1 on page 3-2](#)) provides the following:

- Multi-dual modulus prescaler
- 5-V regulator
- Super filter 8.6-V regulator
- Fixed divide-by-8 circuit for the reference oscillator
- Programmable divide-by-N and charge pump phase detector to support the second injection VCO

The synthesizer IC (see [Figure 3-2 on page 3-2](#)) provides:

- Reference divider
 - Phase modulator
 - Dual-bandwidth adaptive filter
 - Ramp generator
 - Sample-and-hold phase detector
 - Programmable loop divider
 - Auxiliary output bits for system control
-

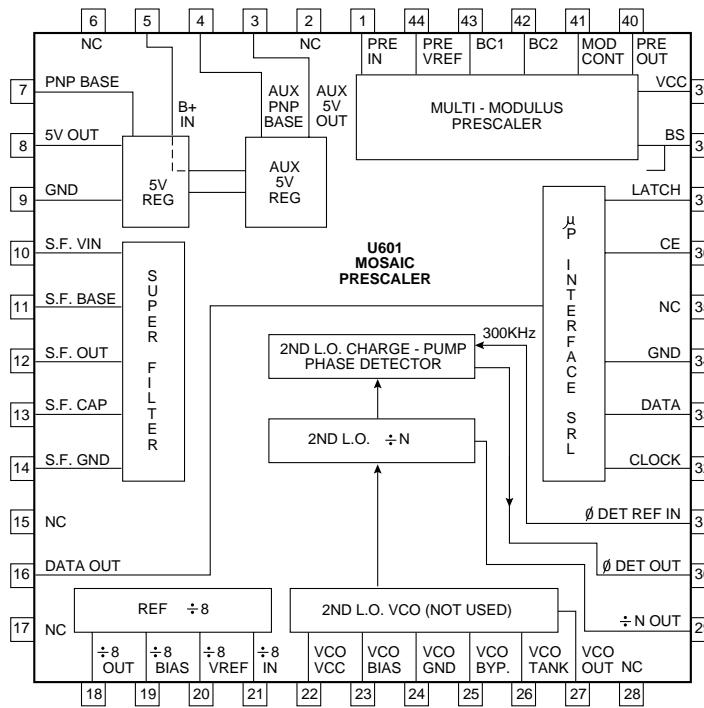

MAEPF-25181-O

Figure 3-1. Prescaler IC Block Diagram

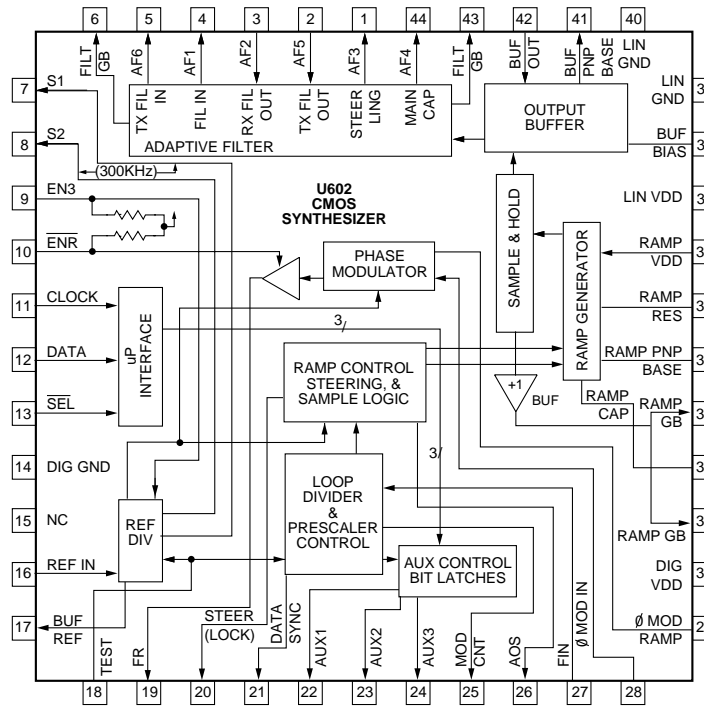

MAEPF-25182-O

Figure 3-2. Synthesizer IC Block Diagram

The reference oscillator generates the 16.8 MHz signal that serves as the reference for all radio frequency accuracy. It uses a proprietary temperature compensation circuit to keep the radio within its specified frequency tolerance.

The receiver back-end uses the ABACUS II IC (U301) to demodulate all the way to baseband, starting from the first IF.

3.1.2 Synthesizer

This section discusses the synthesizer components and detailed theory of operation.

3.1.2.1 Reference Frequency Generation

The reference oscillator (U600) generates a 16.8 MHz reference signal that is tuned onto frequency via a DC-fed varactor input. The digital/analog IC (U502), which is on the command board and is under the control of the serial data bus, generates the DC voltage to the varactor. The reference signal from U600-3 is capacitively coupled into the prescaler (U601-21), where it is divided by 8. The resulting 2.1 MHz signal is routed to the synthesizer IC (U602).

The 2.1 MHz signal is divided by 7, with the result, a 300 kHz signal, serving the following purposes:

- Input to the prescaler IC for second VCO reference
- A source for the negative voltage generator
- Input to the programmable reference divider

3.1.2.2 First VCO Frequency Generation

For reasons of clarity and simplicity, 800 MHz is used as the example product in all synthesizer text. In the 800 MHz models, the feedback is taken before the doubler circuit of the VCO. Band-to-band and kit-to-kit variations are noted in the text as required.

The first VCO in ASTRO radios is a thick-film hybrid transmission line resonator. Its frequency is controlled by a DC-fed varactor bank.

A transmission line feedback path from J601-1 to C604 couples the output frequency back to the prescaler. The signal from the prescaler output (U601, pin 40) is routed to the synthesizer input (U602, pin 27), where it is divided by the A&B counters of the loop divider. The loop equations required for calculating the counter values are as follows:

NOTE: These are examples — the prescaler modulus and the reference frequency are programmable and vary from band-to-band. The examples that follow are for 800 MHz and assume:

$P / P + 1 = 255 / 256$ and $F_r = 6.25$ kHz. For UHF and VHF, $P / P + 1 = 127 / 128$ and $F_r = 5$ kHz.

EQUATION: $N = F_{vco} / F_r$

EXAMPLE: $N = (F_{vco} / F_r) = (403 \text{ MHz} / 6.25 \text{ kHz})$ or $N = 64,480$

EQUATION: $A = (\text{fractional remainder of } N / P) (P)$

EXAMPLE: $A = N / P = (72,000 / 255) = 252.8627$; $.8627 \times 255$
or $A = 220$

EQUATION: $B = [N - \{A \times (P + 1)\}] / P$

EXAMPLE: $B = [64,480 - \{220 \times (255+1)\}] / 255$ or $B = 32$

Plug in the calculated numbers to test the value of N with the following equation:

EQUATION: $N = B (P) + A (P + 1)$

EXAMPLE: $N = (32) (255) + (220) (256)$ or $N = 64,480$

The synthesizer generates a modulus control output which instructs the prescaler to divide by either P or $P + 1$ (that is, 255 or 256). When modulus control is low, the prescaler is dividing by $P + 1$ (256) and the A counter is running; when modulus control is high, the prescaler is dividing by P (255) and the B counter is running. One complete cycle of loop division is repeated for each reference period.

Assume that the VCO is operating correctly at 403 MHz, and the reference frequency is 6.25 kHz. The prescaler and loop divider work in tandem to divide the VCO frequency down to the reference frequency. The waveforms in [Figure 3-3](#) depict what happens in a locked system. Notice in the waveforms that the leading edge of F_r goes high to turn on the constant current source Q607. The ramp capacitor (C634) begins to charge through Q607 and R627, charging at a constant rate, while the prescaler and loop divider are dividing the VCO frequency by N (64,480 in the example). At this point, the loop divider generates a loop pulse (F_v) which turns off the current source.

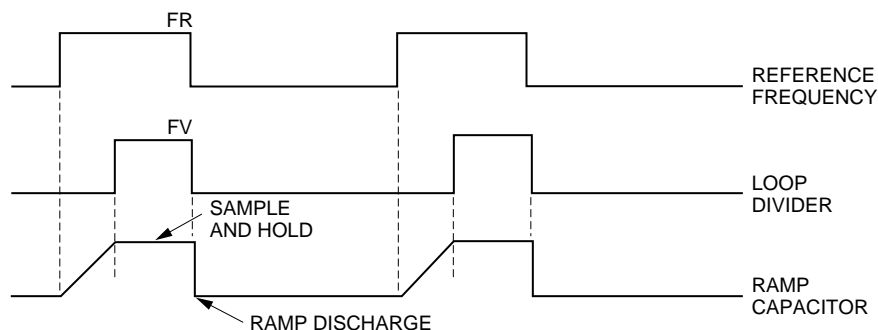

MAEPF-25183-O

Figure 3-3. Loop Divider Waveforms

The voltage that was on C634 is sampled and held by the phase detector. This voltage is amplified approximately 1.8 times and applied to the VCO varactors via the adaptive loop filter and the steering line. This event is repeated at the reference rate so that frequency errors will always be corrected.

NOTE: In VHF receive mode, for frequencies divisible only by 2.5 kHz (for example, 146.0025 MHz), capacitor C670 will be switched in parallel with C634 by Q670. The reference frequency will be 2.5 kHz instead of 5.0 kHz or 6.25 kHz. In transmit mode, the 2.5 kHz reference is not used.

Assume that the VCO frequency tends to drift low. If this happens, the loop pulse will occur at some later time. The current source still begins at the rising edge of F_r but it stays on longer because the leading edge of F_v has been time delayed. Thus, C634 charges to a higher value and the steering line drives the VCO to a higher frequency. The opposite case also applies.

3.1.2.3 Programmable Reference Divider

The reference frequency for 800 MHz is 6.25 kHz; for VHF and UHF, the typical reference frequency is 5.0 kHz. In VHF radios, the reference frequency is 2.5 kHz for receive frequencies not evenly divisible by 5.0 kHz or 6.25 kHz.

3.1.2.4 Phase Modulator

ASTRO radios use a dual-port modulation scheme. The nature of the synthesizer loop is to track out low-frequency errors. In order to enable low-frequency modulation, such as DPL, the reference signal is modulated with the same signal as the VCO. Effectively, this prevents the low-frequency error in the loop (DPL) from tracking out because the same error is on the reference signal. The net effect is that the leading edge of the reference pulse is time-varying at the same rate as the loop pulse; therefore, there is no phase error between the two signals and low-frequency modulation is allowed to pass.

The phase modulation comparator has two inputs: U602, pins 28 and 29. R625 and C630 form an exponential ramp into the plus side of the comparator on U602, pin 29. This ramp is tickled at the reference rate. R626 and C631 form an integrator through which modulation is applied to the minus side of the comparator. The comparator trips when the ramp voltage reaches the voltage on U602, pin 28. The output of the comparator is the time-shifted leading edge of F_r .

3.1.2.5 Loop Filter

ASTRO radios use a switchable, dual-bandwidth loop filter. They also use adaptive filter switching to achieve fast lock. The output of the phase detector is routed to an external device (Q608), the output of which is routed back into the IC for proper filter path selection.

In normal operation, the high drive buffer output is routed through the appropriate transmission gates into the selected filter. A simplified schematic is shown in [Figure 3-4](#).

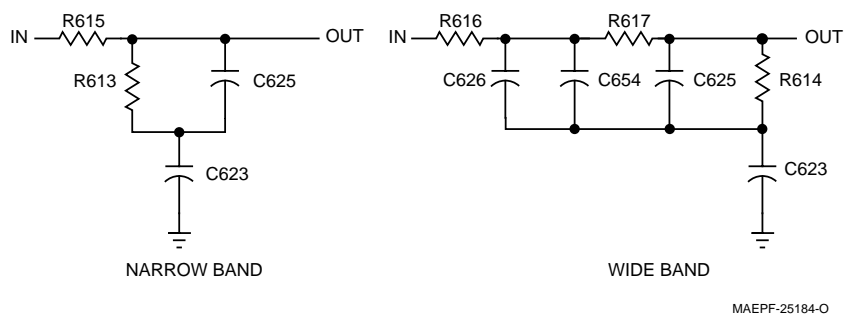

Figure 3-4. Loop Filter Schematic

The loop filters greatly minimize voltage transients that contribute to system hum and noise but, due to their lowpass nature, it takes considerable time to change the average charge in the filters. Therefore, the adapt scheme was implemented. When the radio is changing frequency, the loop goes into the adapt mode. Selected transmission gates in the IC effectively place a short across the resistors in the filter (eliminating associated RC time constants) and quickly charge the loop filter capacitors to the correct steering line voltage for the new frequency. At the end of the adapt sequence, the appropriate filter is reconnected via internal transmission gates.

3.1.2.6 Auxiliary Control Bits

The auxiliary control bits are system control outputs whose states are controlled by the microprocessor via the serial data bus. AUX 1 and AUX 2 are sent to the first VCO to control pin shift states. AUX 3 controls the state of the negative steering line.

3.1.2.7 Second VCO

The second VCO is a grounded-gate, FET Colpitts oscillator. The resonator consists of a fixed inductor and a varactor. A potentiometer, R634, adjusts the negative voltage to the varactor. This adjustment is performed at board test to bring the phase detector output to the center of its linear region; that is approximately 2.25 V. (For HRN6014D, HRN6020C, HRN6019C, HRN4009D, HRN4010C and later RF board kits, a voltage divider consisting of R633 and R635 brings the phase voltage detector output to the center of its linear region (2.25 V), eliminating the adjustment at board test.) The negative voltage is filtered by R611 and C612. The oscillator output is coupled into the IF IC (U301) as a second injection source. It is also fed back to the prescaler (U601, pin 26) for phase locking.

The prescaler contains a programmable, single modulus, divide-by-N circuit, and a charge pump phase detector. The reference frequency (F_r) is 300 kHz and comes in on U601, pin 31. The low-side injection oscillator runs at 109.2 MHz and is divided by 364 inside the IC. The phase detector in the chip compares the divided signal to F_r and either sources or sinks current, as necessary, in order to maintain frequency control.

The phase detector output is routed to the varactor via decoupling choke L604. A divide-by-N test point is also provided from U601, pin 29.

3.1.2.8 Power Distribution

The command board provides all power to the synthesizer in the form of 9.6 Vdc. The prescaler has onboard voltage regulators for 5 V and super filter 8.6 V. The 5-V regulator drives the external series pass device Q602; the super filter's pass device is Q603.

3.1.3 Receiver Back-End

This section discusses the receiver back-end components and detailed theory of operation.

3.1.3.1 First IF

The 109.65 MHz IF signal reaches the RF board via a connector J350. Transistor Q350 amplifies the signal approximately 9dB and supplies the proper impedance for crystal filter Y350. (For HRN6014D, HRN6020C, HRN6019C, HRN4009D, HRN4010C and later RF board kits, amplification circuitry consisting of transistors Q350 and Q354 amplifies the signal approximately 9dB and supplies the proper impedance for crystal filters FL350 and FL351.)

Transistor Q351 supplies filtered A+ for powering Q350 and the receiver front-end. Transistor Q352 switches the filtered A+ supply by reducing the base current from Q351.

NOTE: Since there is 12.5 Vdc on J350, it is important to use a DC block when connecting J350 to an external source.

Y350 is a 4-pole crystal filter, consisting of two independent 2-pole crystal filters contained in a single package. The filter package has a polarization mark located on the top to ensure proper installation.

Y350 supplies the 109.65 MHz IF selectivity and its output passes through a matching network and then goes to ABACUS II IC (U301) pin 30.

(For HRN6014D, HRN6020C, HRN6019C, HRN4009D, HRN4010C and later RF board kits, FL350 and FL351 are 2-pole crystal filters which supply the 109.65 IF selectivity. The output passes through a matching network and goes to the ABACUS II IC (U301), pin 30.)

3.1.3.2 ABACUS II IC

Once in the ABACUS II IC (U301), the first IF frequency is amplified and then down converted to 450 kHz, the second IF frequency. At this point, the analog signal is converted into two digital bit streams by a sigma-delta A/D converter. The bit streams are then digitally filtered and mixed down to baseband and filtered again. The differential output data stream is then sent to the VOCON board where it is decoded to produce the recovered audio.

The ABACUS II IC is electronically programmable, and the amount of filtering, which is dependent on the radio channel spacing and signal type, is controlled by the microcomputer. Additional filtering, which used to be provided externally by a conventional ceramic filter, is replaced by internal digital filters in the ABACUS II IC.

The ABACUS II IC contains a feedback AGC circuit to expand the dynamic range of the sigma-delta converter. The differential output data contains the quadrature (I and Q) information in 16-bit words, the AGC information in a 9-bit word, imbedded word sync information and fill bits dependent on sampling speed. A fractional-n synthesizer is also incorporated in the ABACUS II IC for the 2nd LO generation.

The second LO/VCO is a Colpitts oscillator (see Section [3.1.2.7, "Second VCO," on page 3-6](#)). Its output feeds into the ABACUS II IC on pin 35, providing injection to the second mixer for converting the IF frequency to 450 kHz.

3.2 Command Board

This section of the theory of operation provides a detailed circuit description of the ASTRO Digital Spectra Command Board. When reading the Theory of Operation, refer to your appropriate schematic and component location diagrams located in [“Chapter 7. Schematics, Component Location Diagrams and Parts Lists”](#). This detailed Theory of Operation will help isolate the problem to a particular component. However, first use the *ASTRO Digital Spectra and Digital Spectra Plus Mobile Radios Basic Service Manual* to troubleshoot the problem to a particular board.

The command board includes the following integrated circuits:

- U401, U402 — Differential Amplifiers
- U450 — Audio Amplifier
- U500 — Regulator/Power Control IC (RPCIC)
- U501 — 555 Timer
- U502 — D/A Converter
- U503 — Precision Voltage Regulator
- U522 — Serial Input/Output IC (SIOIC)
- U523, U524 — Analog Switch
- U526 — RS232 Level Shifter
- U530 — 8-Bit Shift Register

3.2.1 Microcontroller and Support ICs

The microcontroller and support ICs are located on the VOCON board, and are interconnected to the command board via connector P501. The control lines linking the boards are either drivers or receivers, depending upon their application. The VOCON board is responsible for decoding or encoding ASTRO and analog data, and producing receive audio and transmit deviation.

3.2.2 Serial Input/Output IC

The serial input/output IC (SIOIC), U522, is a special-function logic/linear integrated circuit. In the ASTRO mobile application, the device provides power-on reset, power control, and bipolar driver/receivers for serial communication. The SIOIC supports the following functions:

1. A buffer for push-to-talk (PTT) to SLIC (U522, pins 37 and 38). Normally a contact closure for PTT is detected by the control head, which sends a command to the VOCON board via the external serial bus protocol. However, some applications require direct PTT control. To generate PTT via the buffer inverter (pin 37), a contact closure to ground at J502, pin 24, or from the accessory connector P503, pin 17, will generate a logic high to the SLIC device (U206, port PH6) on the VOCON board.
2. A buffer for the Busy signal from the VOCON board to the external bus (Busy Out) and the return path back to the VOCON board (Busy RTS). This function is described in Section [3.2.6, "Serial Communications on the External Bus," on page 3-11](#).
3. A buffer for Data Transmission from the VOCON board to the External Bus and a received data return to the VOCON board. This function is described in Section [3.2.6, "Serial Communications on the External Bus," on page 3-11](#).
4. Inputs to sense Switched B+ or Emergency enabling the Power Regulators and provide the switched +5-V regulated supply. This function is described in Section [3.2.3, "Power-Up/Down Sequence," on page 3-9](#).
5. Power-on reset (POR*) circuits provide reset to the Host processor (U204). This function is described in Section [3.2.5, "Reset Circuits," on page 3-10](#).

3.2.3 Power-Up/-Down Sequence

Normally, switched B+ (SWB+) enters the command board from P502, pin 31. This voltage is derived from the battery A+ voltage which enters the control head through P502, pin 30. A power FET transistor, located in the control head (W5 and W7 models), provides the means of controlling the main power source via the control head's on/off switch.

When SWB+ or EMERG become active, the RPCIC EN output (U522, pin 15) goes to a logic low, enabling the Switched +5-V and +9.6-V regulators of the RPCIC (U500). Approximately 220 ms after the B+ is active (see Waveform W1), the power-on-reset (POR*) from U522, pin 40 switches to a logic 1 state, enabling the microprocessor on the VOCON board. The microprocessor then completes an initialization sequence and sets Row 5/5-V enable input to a logic low at P501, pin 15. The input provides a low to the SIOIC to hold the 9.6-V enable on. Therefore, if SWB+ or EMERG go inactive, the regulators will remain enabled until the microcontroller turns them off by returning the 9.6/5-V EN state to a logic high. (This is especially true with emergency, since the foot switch is usually momentary.)

The emergency input is provided to enable the radio transceiver to be activated, regardless of the state of the control head's on/off power switch. The emergency input (EMERG) is activated by opening the normally grounded foot switch connected to either P502, pin 3 or P503, pin 24. This input is routed to the SIOIC (U522, pin 31) and is internally connected to a pull-up resistor within the IC to provide the logic 1 state change.

This change is inverted through an exclusive OR gate within the IC, outputting a logic 0 at pin 30 and the NOR gate input (internal to the IC) to enable the 9.6-V regulator. The logic low at pin 30 is connected to a time-out timer, which latches the 9.6-V enable output for 100 ms. This delay is required to allow the VOCON microprocessor to initiate its start-up vectors and poll the emergency interrupt input from P501, pin 16. The microprocessor takes control of the 9.6 V (P501, pin 15), holding it active low regardless of the states of other inputs.

The emergency active state depends on the emergency polarity (EMERG POL) input to the SIOIC (U522, pin 32). When the jumper JU502 is installed, emergency is active with the foot switch open. Removing JU502 causes the emergency to go active with the switch closed.

To turn off the radio, SWB+ is taken inactive (- Vdc) by pressing the on/off switch on the control head. The microcontroller periodically audits the SWB+ at its input port (pin 20) to determine if it has returned to a logic high. When it sees the logic high condition (caused by an inactive switch), the microcontroller initiates the power-down sequence, turning the voltage regulators and the radio off.

3.2.4 Regulators

The regulator circuits include an unswitched +5 V (UNSW5V) discrete circuit, and the regulator/power-control IC (RPCIC) that produces switched +5 V (U500, pin 14) and 9.6 V (U500, pin 17). The UNSW+5-V source is used by the RPCIC as a reference (U500, pin 20) for its switched + 5-V source. This regulated voltage is produced from the A+ voltage and is present when the battery is connected. The regulators within the RPCIC are controlled by the input to pin 24 via a digital transistor, Q538. This device is controlled from an output (9.6/5-V enable) of the SIOIC (U522, pin 15).

The various voltages used by the ICs on the command board are shown in [Table 3-1](#).

Table 3-1. Integrated Circuits Voltages

Integrated Circuit	UNSW5V	SW +5V	SW +9.6V
Serial Input/ Output (SIOIC)	U522-6, -24	U522-3, -12	U522-14
Regulator/ Power Control (RPCIC)	U500-20	U500-14	U500-17
Digital/ Analog IC (DAIC)		U502-1, -28	
Analog Switch			U523-16, U524-14
RS232 Driver (IC)		U526-19	
555 Timer (IC)		U501-8	
8-Bit Shift Register		U530-16	
Differential Amplifiers			U401-4, U402-4

3.2.5 Reset Circuits

The reset circuits consist of the power-on reset (POR), high-/low- battery voltage reset, and the external bus system reset. The reset circuits allow the microcontroller to recover from an unstable condition, such as no battery on the radio, battery voltage too high or too low, and remote devices on the external bus not communicating.

When the battery (A+) is first applied to the radio, the unregulated voltage source powers the unswitched +5-V regulator and the SIOIC internal regulator. The voltage is also sent to the control head, where it is switched on/off by a series FET transistor. The transistor returns the voltage to the command board, via connector P502-31, as switched B+. The switched B+ voltage is sensed by the SIOIC on pin 28, and changes the state of the 9.6-V enable output gate (RPCIC_EN*) to an active "low." The low state turns on the 9.6-V regulator (U500-24), and its regulated output is fed back to the input of the voltage comparator on the SIOIC (U522-14). The comparator output switches to a logic low upon exceeding the 5.6-V threshold (see [Figure 3-5 on page 3-11](#)).

The three inputs to the NOR gate (SW9.6-V, RPCIC EN, and RPCIC_EN delayed) must be at a logic low to enable the power-on reset (POR*) to a high logic state. During this power-up sequence, this reset is delayed approximately 170 ms after the B+ voltage is sensed. This delay is needed to allow the supply voltages and oscillators to stabilize before releasing the VOCON board's microprocessor. [Figure 3-5](#) illustrates the internal function of the POR* within the SIOIC device.

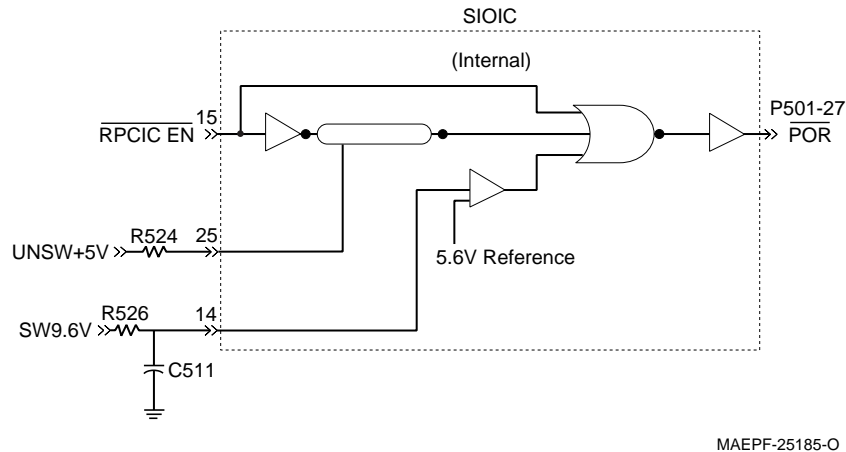

MAEPF-25185-O

Figure 3-5. Power-on Reset

3.2.6 Serial Communications on the External Bus

Serial communications on the external bus use the BUS+ (J502-25), BUS- (J502-22), and BUSY (J502-9) lines.

These three lines are bidirectional; therefore, numerous devices can be in parallel on the bus. All devices monitor the bus while data is being transmitted at a 9600-baud rate. The transmitted data includes the address of the device for which the data is intended. Examples of the different types of data are: control head display data and button closure data.

Data bus drivers for the BUS+ and BUS- lines are differentially driven, having BUS- inverted from the state of BUS+. The idle states are: BUS+, a logic high; and BUS-, a logic low. The drivers are so designed that any of the devices on the bus can drive these lines to their non-idle state without loading problems.

In a typical transmission, the microcontroller examines the BUSY line. If the BUSY line is in the idle state, the microcontroller sets the BUSY line and then transmits. At the end of transmission, the microcontroller returns the BUSY line to idle. The microcontroller sets the BUSY line via microcontroller pin 30, SIOIC pins 10 and 13, and J502-9.

Data transmission is sent onto the bus asynchronously. When the microcontroller sends data onto the bus, the microcontroller also monitors the transmitted data as a collision detection measure. If a collision is detected as a result of receiving a different data pattern, the microcontroller will stop transmission and try again. The microcontroller monitors and receives data via the BUS+ line (J502-25) to the SIOIC (U522, pin 17) and the BUS- line (J502-22) to the SIOIC (U522, pins 18 and 20), and pin 20 of the microcontroller. Data is transmitted from microcontroller pin 19 to the SIOIC to BUS+ (J501, pin 25), and the SIOIC to BUS- (J501, pin 22).

In the remote version of the radio, option cards can be installed. If data transmission is required, data is transmitted from J502-20 to SIOIC pin 19, then from the SIOIC to BUS+ (J501, pin 25), and the SIOIC to BUS- (J501, pin 22).

3.2.7 Synchronous Serial Bus (MOSI)

The synchronous serial bus is an internal bus used by the microcontroller for communicating with various ICs. The serial bus, called MOSI (master out/ slave in), is used to program the digital-to-analog (D/A) converter IC (U526), the serial-to-parallel shift register (U530) on the command board, and the ABACUS II IC (U301) on the RF board. The MOSI data is sent from the VOCON board's microprocessor (U204) through the ADSIC input/output IC (U406) and enters the command board through P501, pin 9. This serial bus has an associated clock and individual select lines for steering the data to one of the three possible devices.

The clock and data are routed in parallel to all serially programmed ICs. The ICs are programmed one-at-a-time by the microcontroller, with each IC ignoring activity on its clock and data lines unless it has been selected.

3.2.8 Received Audio

The received audio is sent from the ADSIC D/A converter as the SDO signal. The audio enters the command board at P501, pin 40, and is routed to the analog multiplex gate (U524, pin 1). The gate's output (U524, pin 2) is paralleled with the output of a second multiplex gate (U524, pin 9) and sent to voltage divider R455 and R456. The voltage divider provides the required attenuation for minimum/maximum volume control settings. Capacitor C454 provides a DC block and couples the audio into U450, pin 2 for amplification.

The two multiplex gates provide control of either receive audio or vehicular repeater audio. These gates are controlled by the inputs to U524, pin 13 and U524, pin 6 from the serial shift register, U530. The independent inputs are software selected by the VOCON's microcontroller.

The audio power amplifier (PA), U450, is a DC-coupled-output bridge-type amplifier. The gain is internally fixed at 36 dB. Speaker audio leaves U450 on pins 11 and 13. For dash-mount models, the audio is routed to the speaker via P503, pins 14 and 16. The amplifier is biased to one half of the A+ voltage and connected directly to the speaker from the rear accessory connector (J2, pins 6 and 7). *The speaker outputs must NOT be grounded in any way.* An audio isolation transformer must be used if grounded test equipment (such as a service monitor) is to be connected to the speaker outputs.

When the radio is squelched, the audio PA is disabled by the VOCON board's controller, providing a low output state to P501, pin 44 (speaker-enable input). The low input turns off Q401 and Q400, removing SWB+ voltage to the audio PA, U450. When U450, pin 10 does not have SW+B applied, the speaker is totally muted and the audio PA current drain is greatly reduced. Diode CR402 (not normally installed) is used when a vehicular repeater is installed and audio muting is required.

A second output for filtered receive audio is provided to drive accessory hardware. The output of P501, pin 49 (MOD IN/DISC AUDIO) is primarily used for transmitter modulation. In the receive mode, the digital signal processor (DSP), via ADSIC, outputs audio at a fixed level (approximately 800 mV pp). This output can be connected to the accessory connector (P503, pin 21) by selecting the appropriate jumper settings.

3.2.9 Microphone Audio

The mobile microphone connects to the front of the control head through connector P104. Microphone high audio enters the command board via P502, pin 6 and is routed to differential amplifier buffer U402. Resistors R414 and R415 provide 9.6-V bias voltage for the microphone's internal circuitry. Amplifier U402 pre-emphasizes and limits the incoming microphone audio through components C462, R407, C463, and R408, which perform an active filter function. Components R441, R442, C467, C465, R443, C466, and C568 provide de-emphasis, developing the required clamped microphone audio, referred to as "mic audio in" (MAI).

3.2.10 Transmit Deviation

The analog transmit deviation (MAI) enters the VOCON board through P501, pin 39, and is converted to a digital format. The digital representation is processed and pre-emphasized by the DSP processor. The pre-emphasized digital bit stream is converted back to analog by the ADSIC device.

The modulation enters the command board through P501, pin 49 (MOD IN) and P501, pin 48 (REF MOD). The two audio signals are required to compensate for low-frequency non-linearities caused by the loop filter in the VCO. The two transmit modulation signals enter a buffer (U401, pin 5 and U401, pin 3). The outputs are sent to a multiplex gate (U523), used to disable the outputs during the receive mode. The multiplex gate is controlled by the serial shift register (U530), and the control lines (U530, pins 10 and 11) are pulled low in the transmit mode.

The modulation is sent out on U530, pins 14 (MOD IN) and 15 (REF MOD). Modulation from U530, pin 14, is coupled through R400 to a non-inverting amplifier, U401. Resistors R403 and R437 fix the closed-loop output gain to 4. Modulation from U530, pin 15 is coupled through R420 to the second non-inverting amplifier, U401. Resistors R422 and R438 fix the closed-loop output gain to 6. The amplified modulation leaves the command board through J500, pins 11 and 17, and is routed to the RF board to provide the transmit modulation.

3.2.11 RS-232 Line Driver

The U526 device is a driver/receiver IC, capable of interfacing with external hardware that utilizes the RS-232 protocol. The device includes an internal oscillator, a voltage doubler, a voltage inverter, and a level shifter. The IC is sourced by +5 V and outputs digital signals at voltage levels of ± 10 Vdc.

The device accepts incoming RS-232 data and converts it to a 5-V logic level. The command board jumper default settings are arranged to have the RS-232 driver normally connected to the accessory outputs, except when ordered as Motorcycle models.

3.2.12 Flash Programming

The command board provides multiplexing of the receive and transmit data inputs from the control head's microphone connector (P104). The microphone connector is used (during certain conditions) as a Flash programming input port. When the special programming cable is inserted into P104, the "microphone high" line (normally 9.6 V) increases to 13 V, due to internal connections made within the radio interface box (RIB). Zener diode VR401 (and resistor R519), connected to the "Mic Hi" input (P502, pin 6), is forward-biased beyond its breakdown voltage of 11 Vdc. The voltage drop across R516 forward-biases Q401, turning on the transistor. The collector of Q401 pulls the voltage provided by R521 to ground. The change in state causes the multiplex control line (U525, pins 9, 10, 11) to change the gate inputs. The change allows the receive and transmit data paths to be multiplexed to P502, pin 23 (Key Fail), P502, pin 15 (P_RX data), and P502, pin 2 (PTT*/P reset).

3.2.13 Encryption Voltages

The command board produces two voltages that are used by the encryption module: 10-V (9-V on G and earlier boards) constant and 5-V key storage. The constant 10 V is generated using components U604, R608, R609, and C605 (R420, VR403, C457, and Q508 on G and earlier boards) and is fed to pin 38 of P501. On the VOCON board, the 10 V provides continuous unswitched voltage when the vehicular battery is connected to the radio and is also switched via VOCON transistors Q206 and Q207 to provide SWB+ to the encryption module. A 5-V storage circuit comprised of components R532, R533, and C571 (0.47 farad capacitor) provides +5 Vdc to the encryption module via P501 pin 36 to hold encryption keys for a period of three days with no A+ voltage present. Provision is made for a battery holder to replace capacitor C571. The addition of the battery will increase encryption key hold time to approximately one year.

3.2.14 Regulator and Power-Control IC

The regulator and power-control IC (RPCIC), U500, contains internal circuitry for the 9.6-V regulator and the switched +5-V regulator. Refer to Section 3.2.4, "Regulators," on page 3-10 for detailed theory of operation.

The power-control section of the device is responsible for maintaining a constant RF output power. A directional coupler and detector network, located within the RF power amplifier circuit, rectifies the sensed forward power from the last RF gain stage. The detected voltage is routed back to the command board control circuitry (U500) via P503, pin 8. The voltage is then coupled through a buffer amplifier and summed, through a resistor network (R509, R508, and R507), with the transmit power set voltage (U500, pin 6) and the temperature sense voltage. The resulting voltage is applied to the control amplifier's inverting port (U502, pin 2) for automatic RF gain control.

The U500 current-sense inputs, pin 37 (sense +) and pin 38 (sense -), are sourced from the current-sensing resistor on the RF power amplifier. The two inputs are applied to a differential amplifier internal to the RPCIC. The current limit is set by a software-programmable D/A device (U502) that causes a cut back in RF output power when the set limit is exceeded.

The transmitter attack and off times are software programmable to meet domestic and international specifications. Transistors Q514 and Q515 are controlled by a serial shift register (U530). The transistors, when turned on (logic 1 input) cause the output of Q504 (the PA control line) to ramp up slowly to prevent an abrupt RF PA turn-on. The slower rate is required to meet international spurious requirements. When the transistors are turned off, the attack times return to a standard domestic response with fast rise times. Refer to Figure 3-6 for attack time diagrams.

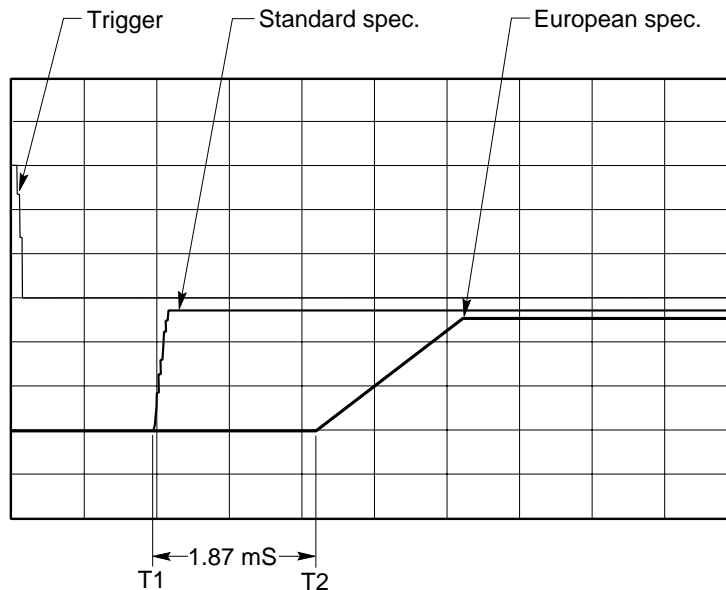

MAEPF-25186-O

Figure 3-6. Transmitter Attack Time

3.3 ASTRO Spectra VOCON Board

This section of the theory of operation provides a detailed circuit description of an ASTRO Digital Spectra Vocoder/Controller (VOCON) board. When reading the Theory of Operation, refer to your appropriate schematic and component location diagrams located in "[Chapter 7. Schematics, Component Location Diagrams and Parts Lists](#)". This detailed Theory of Operation will help isolate the problem to a particular component. However, first use the *ASTRO Digital Spectra and Digital Spectra Plus Mobile Radios Basic Service Manual* to troubleshoot the problem to a particular board.

NOTE: The information in this subsection applies to the **non Plus** VOCON board. Refer to Section [3.4, "ASTRO Spectra Plus VOCON Board," on page 3-38](#) for information on the ASTRO Spectra Plus VOCON board.

3.3.1 General

The VOCON board consists of two subsystems; the vocoder and the controller. Although these two subsystems share the same printed circuit board and work closely together, it helps to keep their individual functionality separate in describing the operation of the radio.

The controller section is the central interface between the various subsystems of the radio. It is very similar to the digital logic portion of the controllers on many existing Motorola radios. Its main task is to interpret user input, provide user feedback, and schedule events in the radio operation, which includes programming ICs, steering the activities of the DSP, and sending messages to the display through the control head.

The vocoder section performs all tone signaling, trunking signalling, conventional analog voice, etc. All analog signal processing is done digitally utilizing a DSP56001. In addition it provides a digital voice plus data capability utilizing VSELP or IMBE voice compression algorithms. Vocoder is a general term used to refer to these DSP based systems and is short for voice encoder.

In addition, the VOCON board provides the interconnection between the microcontroller unit (MCU), digital-signal processor (DSP), command board, and encryption board on secure-equipped radios.

3.3.2 Controller Section

Refer to [Figure 3-7 on page 3-16](#) and your specific schematic diagram.

The controller section of the VOCON board consists entirely of digital logic comprised of a microcontrol unit (MCU-U204), a custom support logic IC (SLIC-U206), and memory consisting of: SRAM (U202), EEPROM (U201), and FLASH ROM (U205).

The MCU (U204) memory system is comprised of a 32k x 8 SRAM (U202), 32k x 8 EEPROM (U201), and 512k x 8 FLASH ROMs (U205). The MCU also contains 1024 bytes of internal SRAM and 512 bytes of internal EEPROM. The EEPROM memory is used to store customer specific information and radio personality features. The FLASH ROM contains the programs which the HC11F1 executes. The FLASH ROM allows the controller firmware to be reprogrammed for future software upgrades or feature enhancements. The SRAM is used for scratchpad memory during program execution.

The SLIC (U206) performs many functions as a companion IC for the MCU. Among these are expanded input/output (I/O), memory decoding and management, and interrupt control. It also contains the universal asynchronous receiver transmitter (UART) used for the RS232 data communications. The SLIC control registers are mapped into the MCU (U204) memory space.

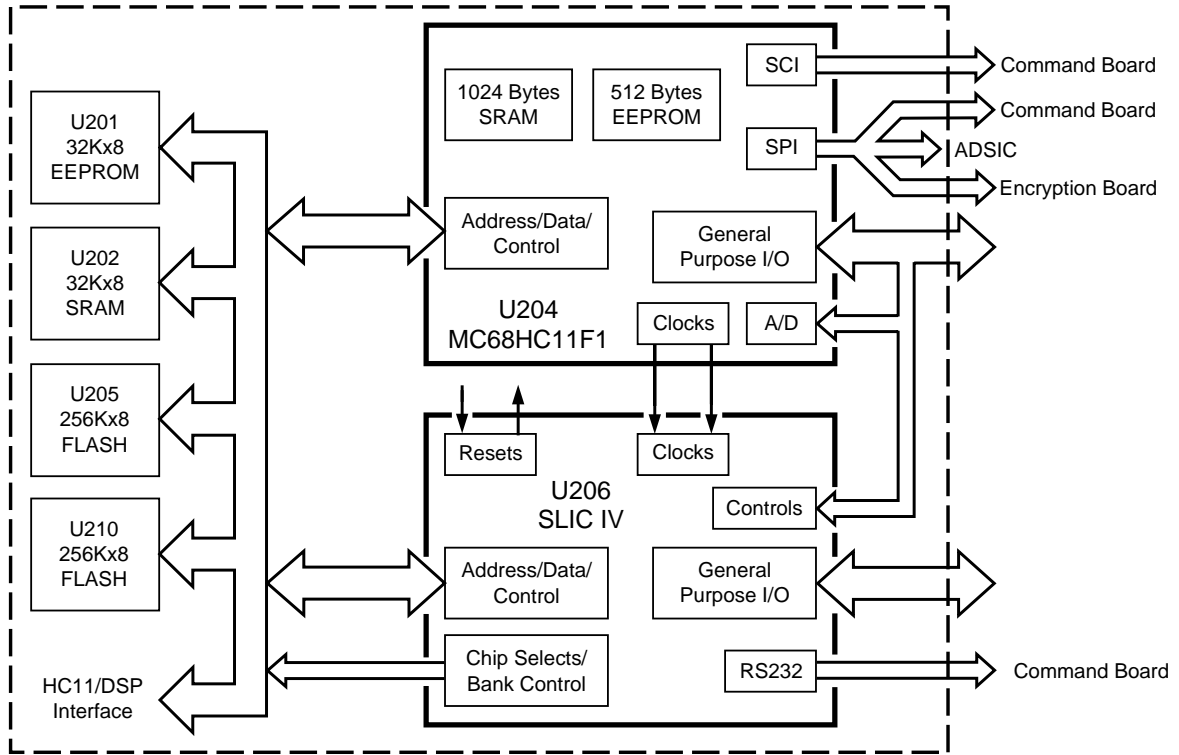

MAEPF-25105-O

Figure 3-7. VOCON Board - Controller Section

The controller performs the programming of all peripheral ICs. This is done via a serial peripheral interface (SPI) bus. ICs programmed through this bus include the synthesizer prescaler, DAIC, and ADSIC. On secure-equipped model, the encryption board is also controlled through the SPI bus.

In addition to the SPI bus, the controller also maintains two asynchronous serial buses; the SB9600 bus and an RS232 serial bus. The SB9600 bus is for interfacing the controller section to different hardware option boards, some of which may be external to the radio. The RS232 is used as common data interface for external devices.

User input from the control head is sent to the controller via the SB9600 bus. Feedback to the user is provided by the display on the control head. The display is 2 line 14 characters on the W3 model, 8 characters on W4, W5, and W7 models, and 11 characters on the W9 model.

The controller schedules the activities of the DSP through the host port interface. This includes setting the operational modes and parameters of the DSP. The controlling of the DSP is analogous to programming analog signaling ICs on standard analog radios.

3.3.3 Vocoder Section

Refer to [Figure 3-8 on page 3-18](#) and your specific schematic diagram.

The vocoder section of the VOCON board is made up of a digital signal processor (DSP) (U405), 24k x24 static-RAM (SRAM) (U414, U403, and U402), 256kB FLASH ROM (U404), and ABACUS II/DSP support IC (ADSIC) (U406).

The FLASH ROM (U404) contains the program code executed by the DSP. As with the FLASH ROM used in the controller section, the FLASH ROM is reprogrammable so new features and algorithms can be updated in the field as they become available. Depending on the mode and operation of the DSP, corresponding program code is moved from the FLASH ROM into the faster SRAM, where it is executed at full bus rate.

The ADSIC (U406) is basically a support IC for the DSP. It provides among other things, the interface from the digital world of the DSP to the analog world. The ADSIC also provides some memory management and provides interrupt control for the DSP processing algorithms. The configuration programming of the ADSIC is performed by the MCU. However some components of the ADSIC are controlled through a parallel memory mapped register bank by the DSP.

In the receive mode, The ADSIC (U406) acts as an interface to the ABACUS II IC, which can provide digital output of I (In phase) and Q (Quadrature) data words directly to the DSP for processing. Or the data can be filtered and discriminated by the ADSIC and data provided to the DSP as raw discriminator sample data. The latter mode, with the ADSIC performing the filtering and discrimination, is the typical mode of operation.

In the transmit mode, the ADSIC (U406) provides a serial digital-to-analog (D/A) converter. The data generated by the DSP is filtered and reconstructed as an analog signal to present to the VCO and Synthesizer as a modulation signal. Both the transmit and receive data paths between the DSP and ADSIC are through the DSP SSI port.

When transmitting, the microphone audio is passed from the command board to the ADSIC, which incorporates an analog-to-digital (A/D) converter to translate the analog waveform to a series of data. The data is available to the DSP through the ADSIC parallel registers. In the converse way, the DSP writes speaker data samples to a D/A in the ADSIC, which provides an analog speaker audio signal to the audio power amplifier on the command board.

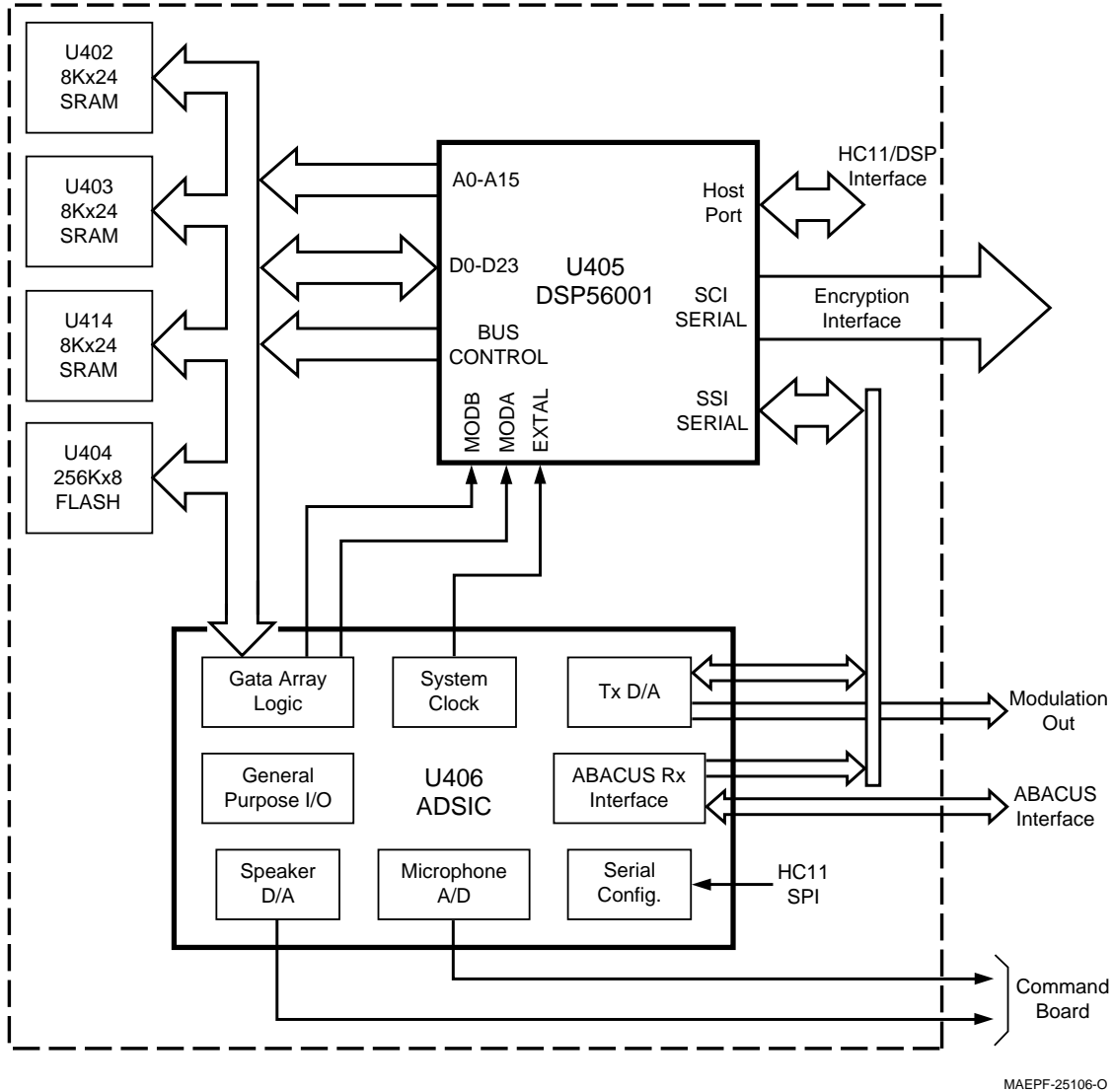

Figure 3-8. VOCON Board - Vocoder Section

3.3.4 RX Signal Path

The vocoder processes all received signals digitally. This requires a unique back end from a standard analog radio. This unique functionality is provided by the ABACUS II IC with the ADSIC (U406) acting as the interface to the DSP. The ABACUS II IC located on the RF board provides a digital back-end for the receiver section. It provides a digital output of I (In phase) and Q (Quadrature) data words at 20 kHz sampling rate through the ADSIC interface to the DSP. Refer to the appropriate transceiver section for details on ABACUS II operation.

The ADSIC interface to the ABACUS II is comprised of the four signals SBI, DIN, DIN*, and ODC (refer to [Figure 3-9](#) on [page 3-19](#)).

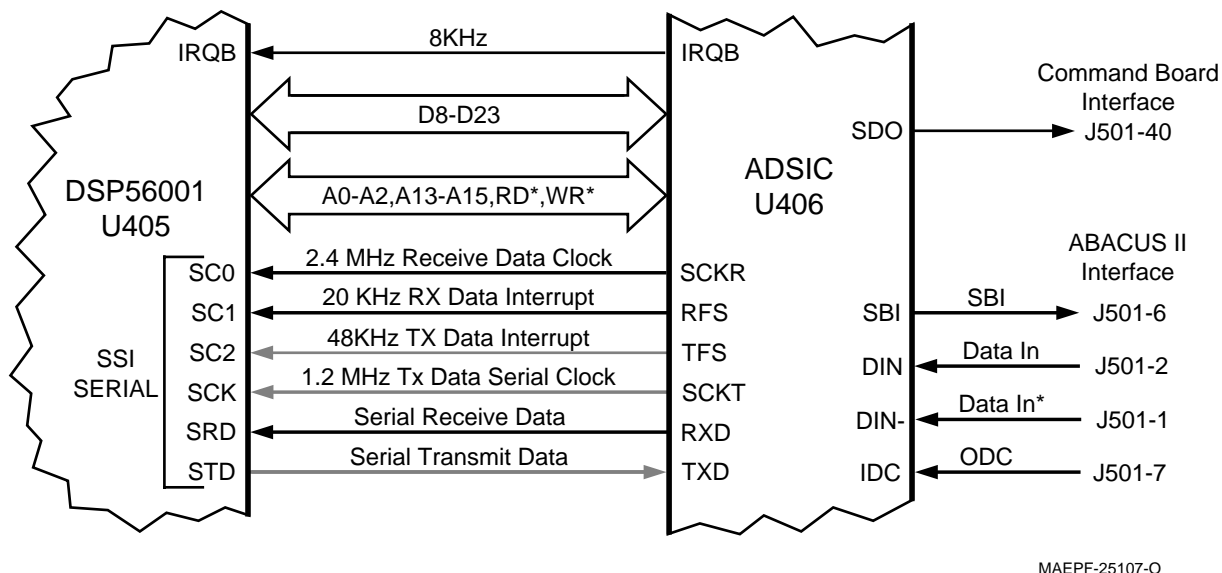

Figure 3-9. DSP RSSI Port - RX Mode

NOTE: An asterisk symbol (*) next to a signal name indicates a negative or NOT logic true signal.

ODC is a clock ABACUS II provides to the ADSIC. Most internal ADSIC functions are clocked by this ODC signal at a rate of 2.4 MHz and is available as soon as power is supplied to the circuitry. This signal may initially be 2.4 or 4.8 MHz after power-up. It is programmed by the ADSIC through the SBI signal to 2.4 MHz when the ADSIC is initialized by the MCU through the SPI bus. For any functionality of the ADSIC to exist, including initial programming, this reference clock must be present. SBI is a programming data line for the ABACUS II. This line is used to configure the operation of the ABACUS II and is driven by the ADSIC. The MCU programs many of the ADSIC operational features through the SPI interface. There are 36 configuration registers in the ADSIC of which four contain configuration data for the ABACUS II. When these particular registers are programmed by the MCU, the ADSIC in turn sends this data to the ABACUS II through the SBI.

DIN and DIN* are the data lines on which the I and Q data words are transferred from the ABACUS II. These signals make up a differentially encoded current loop. Instead of sending TTL type voltage signals, the data is transferred by flowing current one way or the other through the loop. This helps to reduce internally generated spurious emissions on the RF board. The ADSIC contains an internal current loop decoder which translates these signals back to TTL logic and stores the data in internal registers.

In the fundamental mode of operation, the ADSIC transfers raw baseband data to the DSP. The DSP can perform IF filtering and discriminator functions on this data to obtain a baseband demodulated signal. However, the ADSIC contains a digital filter and discriminator function and can provide this baseband demodulated signal directly to the DSP, this being the typical mode of operation. The internal digital IF filter is programmable up to 24 taps. These taps are programmed by the MCU through the SPI interface.

The DSP accesses this data through its SSI port. This is a 6 port synchronous serial bus. It is used by the DSP for both transmit and receive data transferal, but only the receive functions will be discussed here. The ADSIC transfers the data to the DSP on the SRD line at a rate of 2.4 MHz. This is clocked synchronously by the ADSIC which provides a 2.4 MHz clock on SC0. In addition, a 20 kHz interrupt is provided on SC1 signaling the arrival of a data packet. This means a new I and Q sample data packet is available to the DSP at a 20 kHz rate which represents the sampling rate of the received data. The DSP then processes this data to extract audio, signaling, etc. based on the 20 kHz interrupt.

In addition to the SPI programming bus, the ADSIC also contains a parallel configuration bus consisting of D8-D23, A0-A2, A13-A15, RD*, and WR*. This bus is used to access registers mapped into the DSP memory starting at Y:FFF0. Some of these registers are used for additional ADSIC configuration controlled directly by the DSP. Some of the registers are data registers for the speaker D/A. Analog speaker audio is processed through this parallel bus where the DSP outputs the speaker audio digital data words to this speaker D/A and an analog waveform is generated which is output on SDO (Speaker Data Out). In conjunction with the speaker D/A, the ADSIC contains a programmable attenuator to set the rough signal attenuation. However, the fine levels and differences between signal types is adjusted through the DSP software algorithms. The speaker D/A attenuator setting is programmed by the MCU through the SPI bus.

The ADSIC provides an 8 kHz interrupt to the DSP on IRQB for processing the speaker data samples. IRQB is also one of the DSP mode configuration pins at start up. This 8 kHz signal must be enabled through the SPI programming bus by the MCU and is necessary for any audio processing to occur.

For secure messages, the digital signal data must be passed to the secure module for decryption prior to processing speaker data. The DSP transfers the data to and from the secure module through its SCI port consisting of TXD and RXD. The SCI port is a two wire duplex asynchronous serial port. Configuration and mode control of the secure module is performed by the MCU through the SPI bus.

The ADSIC presents the analog speaker audio to the command board's audio power amplifier., which drives an external speaker. For more information on this subject, refer to Section [3.2, "Command Board," on page 3-8.](#)

Since all of the audio and signaling is processed in DSP software algorithms, all types of audio and signalling follow this same path. There is, however, one exception. Low-speed trunking data is processed by the host μ C through the SCLK port of the DSP. This port is connected to port PA0 on the host μ C. The DSP extracts the low-speed data from the received signal and relays it to the host μ C for processing.

3.3.5 TX Signal Path

The transmit signal path follows some of the same design structure as the receive signal path described in Section 3.3.4, "RX Signal Path," on page 3-18 (refer to Figure 3-10). It is advisable to read through the section on RX Signal Path that precedes this section.

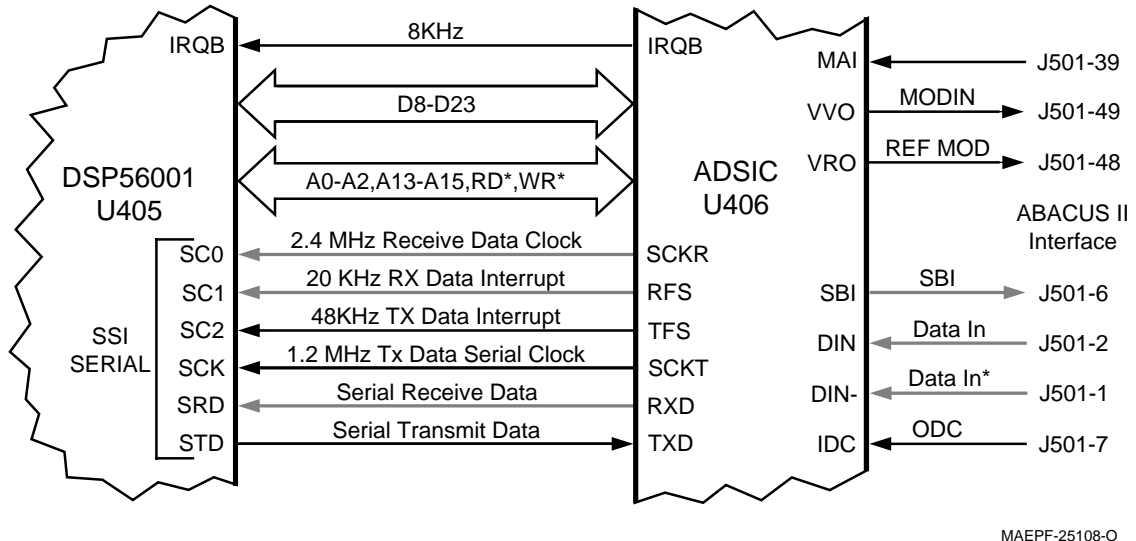

MAEPF-25108-O

Figure 3-10. DSP RSSI Port - TX Mode

The ADSIC contains a microphone A/D with a programmable attenuator for coarse level adjustment. As with the speaker D/A attenuator, the microphone attenuator value is programmed by the MCU through the SPI bus. The analog microphone signal from the command board is input to the A/D on MAI (Mic Audio In). The microphone A/D converts the analog signal to a digital data stream and stores it in internal registers. The DSP accesses this data through the parallel configuration bus consisting of D8-D23, A0-A2, A13-A15, RD*, and WR*. As with the speaker data samples, the DSP reads the microphone samples from registers mapped into its memory space starting at Y:FFF0. The ADSIC provides an 8 kHz interrupt to the DSP on IRQB for processing these microphone data samples.

As with the received trunking low-speed data, low speed Tx data is processed by the MCU and returned to the DSP at the DSP SCLK port connected to the MCU port PA0.

For secure messages, the digital signal may be passed to the secure module for encryption prior to further processing. The DSP transfers the data to and from the secure module through its SCI port, consisting of TXD and RXD. Configuration and mode control of the secure module is performed by the MCU via the SPI bus.

The DSP processes these converted microphone samples, generates and mixes the appropriate signalling, and filters the resultant data. This data is then transferred to the ADSIC IC on the DSP SSI port. The transmit side of the SSI port consists of SC2, SCK, and STD. The DSP SSI port is a synchronous serial port. SCK is the 1.2 MHz clock input derived from the ADSIC, which makes it synchronous. The data is clocked over to the ADSIC on STD at a 1.2 MHz rate. The ADSIC generates a 48 kHz interrupt on SC2 so that a new sample data packet is transferred at a 48 kHz rate which sets the transmit data sampling rate at 48Ksp.

These samples are then input to a transmit D/A, which converts the data to an analog waveform. This waveform is the modulation out signal from the ADSIC ports, VVO and VRO. These signals are both sent to the command board, where they go through a gain stage and then to the VCO and Synthesizer. VVO is used primarily for audio frequency modulation; VRO is used to compensate for low-frequency response to pass Digital Private Line (DPL) modulated signals. The transmit side of the transceiver is virtually identical to a standard analog FM radio.

Also required is the 2.4 MHz ODC signal from the ABACUS II IC. Although the ABACUS II IC provides receiver functions, it is important to note that this 2.4 MHz reference is required for all of the ADSIC operations.

3.3.6 Controller Bootstrap and Asynchronous Buses

The SB9600 bus (see [Figure 3-11 on page 3-23](#)) is an asynchronous serial communication bus, utilizing a Motorola proprietary protocol. It provides a means for the MCU to communicate with other hardware devices. In the ASTRO Digital Spectra radio, it communicates with hardware accessories connected to the accessory connector and the remote interface board.

The SB9600 bus utilizes the UART internal to the MCU, operating at 9600 baud. The SB9600 bus consists of LH/TX_Data (J501-18), LH/RX_Data (J501-17), and Busy_RTS (J501-20) signals. LH/TX_Data and LH/RX_Data are the SCI TXD and RXD ports (U204-PD0 and PD1), respectively. Busy_RTS (U204-PA3) is an active-low signal, which is pulled low when a device wants control of the bus.

The same UART internal to the MCU is used in the controller bootstrap mode of operation. This mode is used primarily in downloading new program code to the FLASH ROMs on the VOCON board. In this mode, the MCU accepts special code downloaded at 7200 baud through the SCI bus instead of operating from program code resident in its ROMs.

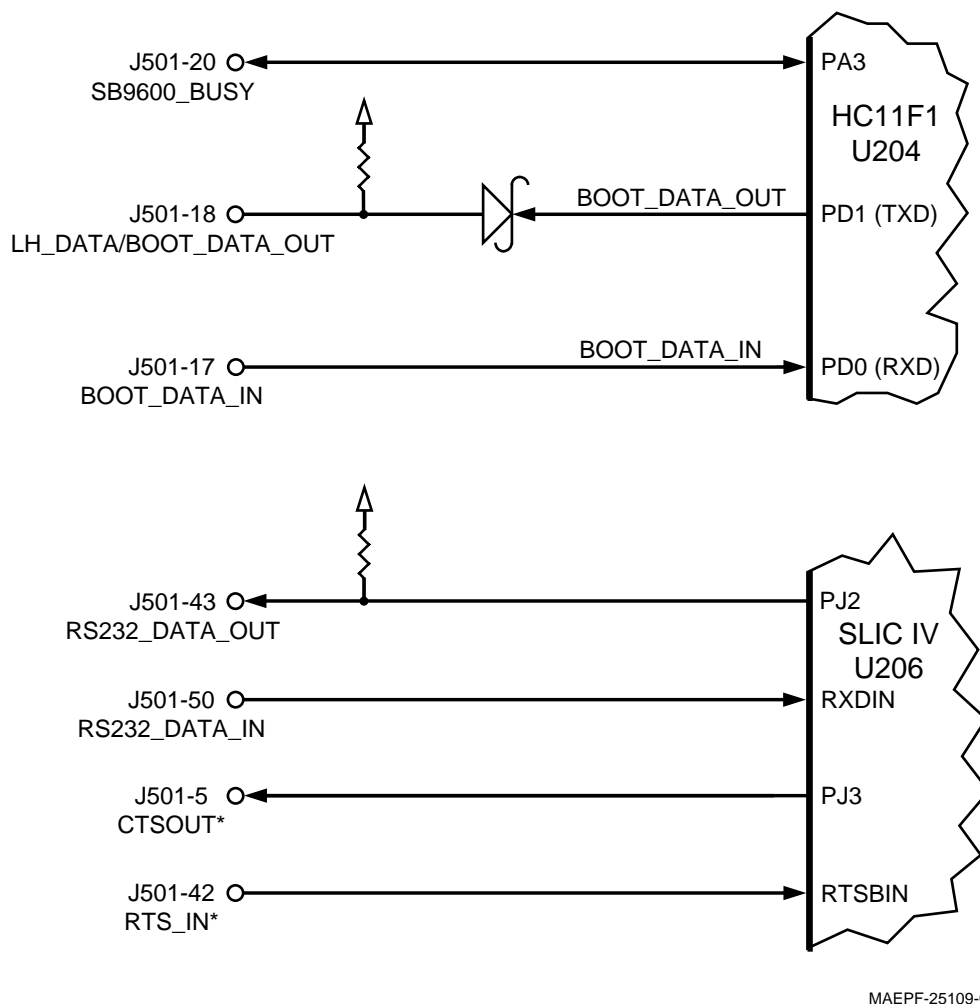

Figure 3-11. Host SB9600 and RS232 Ports

A voltage greater than 10 Vdc applied to J501-31 (Vpp) will trip the circuit comprising Q203, Q204, and VR207. This circuit sets the MODA and MODB pins of the MCU to bootstrap mode (logic 0,0). If the Vpp voltage is raised to 12 Vdc required on the FLASH devices for programming, the circuit comprising VR208, Q211, and Q208 will trip, supplying Vpp to the FLASH devices, U205 and U404.

The ASTRO Digital Spectra radio has an additional asynchronous serial bus which utilizes RS232 bus protocol. This bus utilizes the UART in the SLIC IC (U206). It consists of TX/RS232 (J501-43), RX/RS232 (J501-50), CTS/RS232 (J501-5), and RTS/RS232 (J501-42). It is a four-wire duplex bus used to connect to external data devices.

3.3.7 Vocoder Bootstrap

The DSP has two modes of bootstrap: from program code stored in the FLASH ROM U404, or retrieving code from the host port.

During normal modes of operation, the DSP executes program code stored in the FLASH ROM, U404. Unlike the MCU, however, the DSP moves the code from the FLASH ROM into the three SRAMs, U402, U403, and U414, where it is executed from. Since, at initial start-up, the DSP must execute this process before it can begin to execute system code, it is considered a bootstrap process. In this process, the DSP fetches 512 words, 1536 bytes, of code from the FLASH ROM, starting at physical address \$C000, and moves it into internal P memory. This code contains the system vectors, including the reset vector. It then executes this piece of bootstrap code, which basically in turn moves additional code into the external SRAMs.

A second mode of bootstrap allows the DSP to load this initial 512 words of data from the host port, being supplied by the MCU. This mode is used for FLASH programming the DSP ROM when the ROM may initially be blank. In addition, this mode may be used for downloading some diagnostic software for evaluating that portion of the board.

The bootstrap mode for the DSP is controlled by three signals; MODA/IRQA*, MODB/IRQB*, and D23. All three of these signals are on the DSP (U405). MODA and MODB configure the memory map of the DSP when the DSP reset become active. These two signals are controlled by the ADSIC (U406) during power-up, which sets MODA low and MODB high for proper configuration. Later these lines become interrupts for analog signal processing. D23 controls whether the DSP will look for code from the MCU or will retrieve code from the FLASH ROM. D23 by default is pulled high through R404 which will cause the DSP to seek code from the FLASH ROM (U404) if this line is read high out of reset. This line is also connected to an I/O port on the MCU which can configure it for the second, host port, mode of bootstrap.

3.3.8 Serial Peripheral Interface (SPI) Bus

This bus is a synchronous serial bus made up of a data, a clock, and an individual IC unique select line. It's primary purpose is to configure the operating state of each IC. ICs programmed by this include; ADSIC, Synthesizer, Prescaler, DAIC, and, if equipped, the secure module.

The MCU (U204) is configured as the master of the bus. It provides the synchronous clock (SPI_SCK), a select line, and data (MOSI [Master Out Slave In]). In general the appropriate select line is pulled low to enable the target IC and the data is clocked in. The SPI bus is a duplex bus with the return data being clocked in on MISO (Master In Slave Out). The only place this is used is when communicating with the secure module. In this case, the return data is clocked back to the MCU on MISO (master in slave out).

3.3.9 Controller Memory Map

[Figure 3-12 on page 3-25](#) depicts the controller section memory map for the parallel data bus as used in normal modes of operation. There are three maps available for normal operation, but map 2 is the only one used. In bootstrap mode, the mapping is slightly different and will be addressed later.

The external bus for the host controller (U204) consists of one 32Kx8 SRAM (U202), one 32Kx8 EEPROM (U201), one IMEG FLASH ROM U205, and SLIC (U206) configuration registers. In addition the DSP host port is mapped into this bus through the SLIC address space. The purpose of this bus is to interface the MCU (U204) to these devices

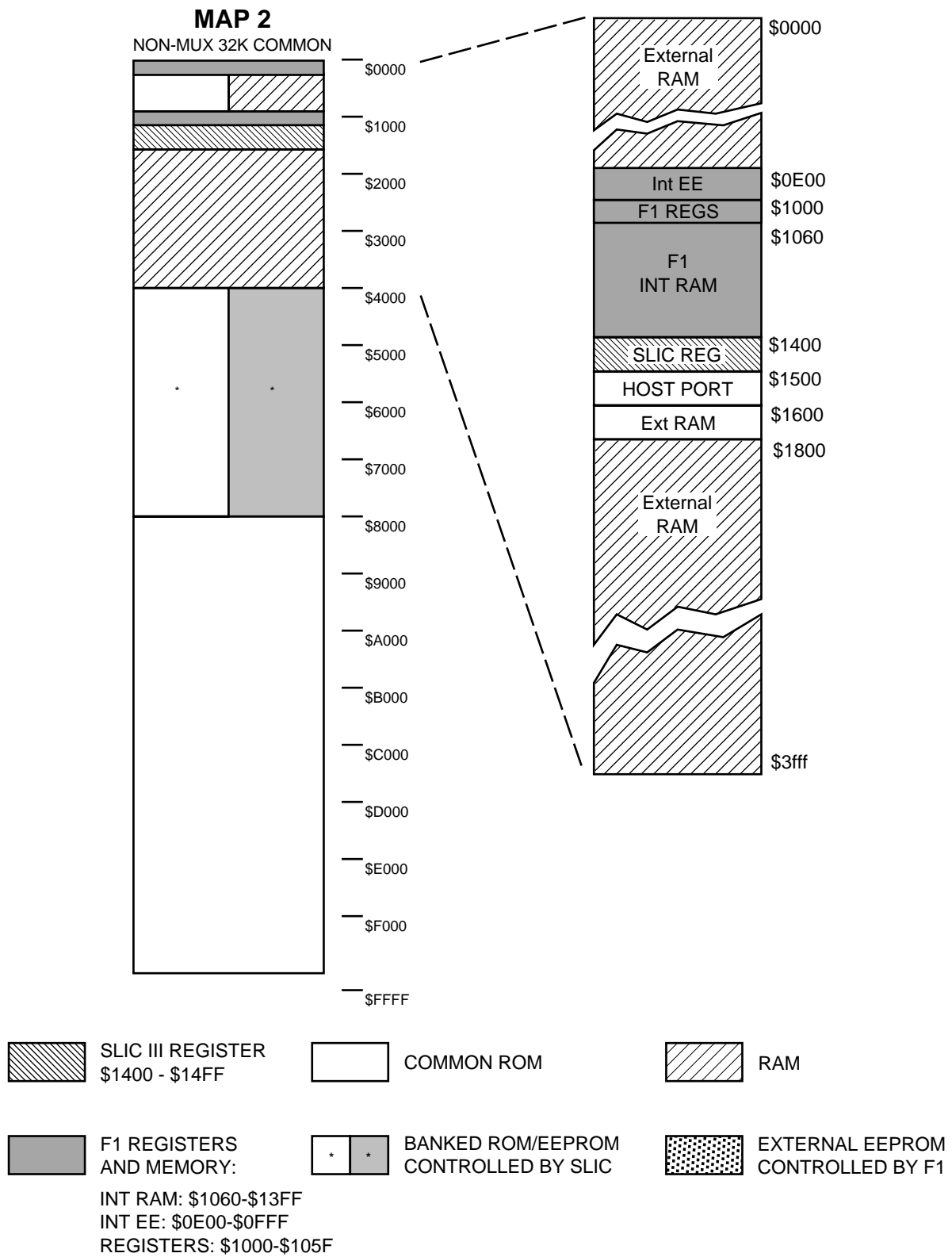

MAEPF-24346-O

Figure 3-12. Controller Memory Mapping

The MCU executes program code stored in the FLASH ROMs. On a power-up reset, it fetches a vector from \$FFFE, \$FFFF in the ROMs and begins to execute code stored at this location. The external SRAM along with the internal 1Kx8 SRAM is used for temporary variable storage and stack space. The internal 512 bytes of EEPROM along with the external EEPROM are used for non volatile storage of customer-specific information. More specifically the internal EEPROM space contains transceiver board tuning information and on power-down some radio state information is stored in the external EEPROM.

The SLIC is controlled through sixteen registers mapped into the MCU memory at \$1400-\$14FF. This mapping is achieved by the following signals from the MCU: R/W*, CSIO1*, HA0-HA4, HA8, HA9. Upon power-up, the MCU configures the SLIC including the memory map by writing to these registers.

The SLIC memory management functions in conjunction with the chip selects provided by the MCU provide the decoding logic for the memory map which is dependent upon the "map" selected in the SLIC. The MCU provides a chip select, CSGEN*, which decodes the valid range for the external SRAM. In addition CSIO1* and CSPROG* are provided to the SLIC decoding logic for the external EEPROM and FLASH ROM respectively. The SLIC provides a chip select and banking scheme for the EEPROM and FLASH ROM. The FLASH ROM is banked into the map in 16KB blocks with one 32KB common ROM block. The external EEPROM may be swapped into one of the banked ROM areas. This is all controlled by EE1CS*, ROM1CS*, ROM2CS*, HA14_OUT, HA15_OUT, HA16, and HA17 from the SLIC (U206) and D0-D8 and A0-16 from the MCU (U204).

The SLIC provides three peripheral chip selects; XTSC1B, XTCS2B, and XTCS3B. These can be configured to drive an external chip select when its range of memory is addressed. XTSC1B is used to address the host port interface to the DSP. XTSC2B is used to address a small portion of external SRAM through the gate U211. XTSC3B is used as general purpose I/O for interrupting the secure module.

In bootstrap mode the memory map is slightly different. Internal EEPROM is mapped at \$FE00-\$FFFF and F1 internal SRAM starts at \$0000-\$03FF. In addition, a special bootstrap ROM appears in the ROM space from \$B600-\$BFFF. For additional information on bootstrap mode, refer to Section 3.3.6, "Controller Bootstrap and Asynchronous Buses," on page 3-22.

3.3.10 Vocoder Memory Map

The vocoder (DSP) external bus consists of three 32k x 8 SRAMs (U401, U402, and U403), one 256k x 8 FLASH ROM (U404), and ADSIC (U406) configuration registers. Refer to Figure 3-13 on page 3-27.

The DSP56001A (U405) has a 24 bit wide data bus (D0-D23) and a 16 bit wide address bus (A0 - A15). The DSP can address three 64k x 24 memory spaces: P (Program), Dx (Data X), and Dy (Data Y). These additional RAM spaces are decoded using PS* (Program Strobe), DS* (Data Strobe), and X/Y*. RD* and WR* are separate read and write strobes.

The ADSIC provides memory decoding for the FLASH ROM (U404). EPS* provides the logic:

$$\overline{A15} \times (A14 \oplus A13)$$

and is used as a select for the ROM. The ADSIC provide three bank lines for selecting 16k byte banks from the ROM. This provides decoding for 128k bytes from the ROM in the P: memory space. PS* is used to select A17 to provide an additional 128k bytes of space in Dx: memory space for the ROM.

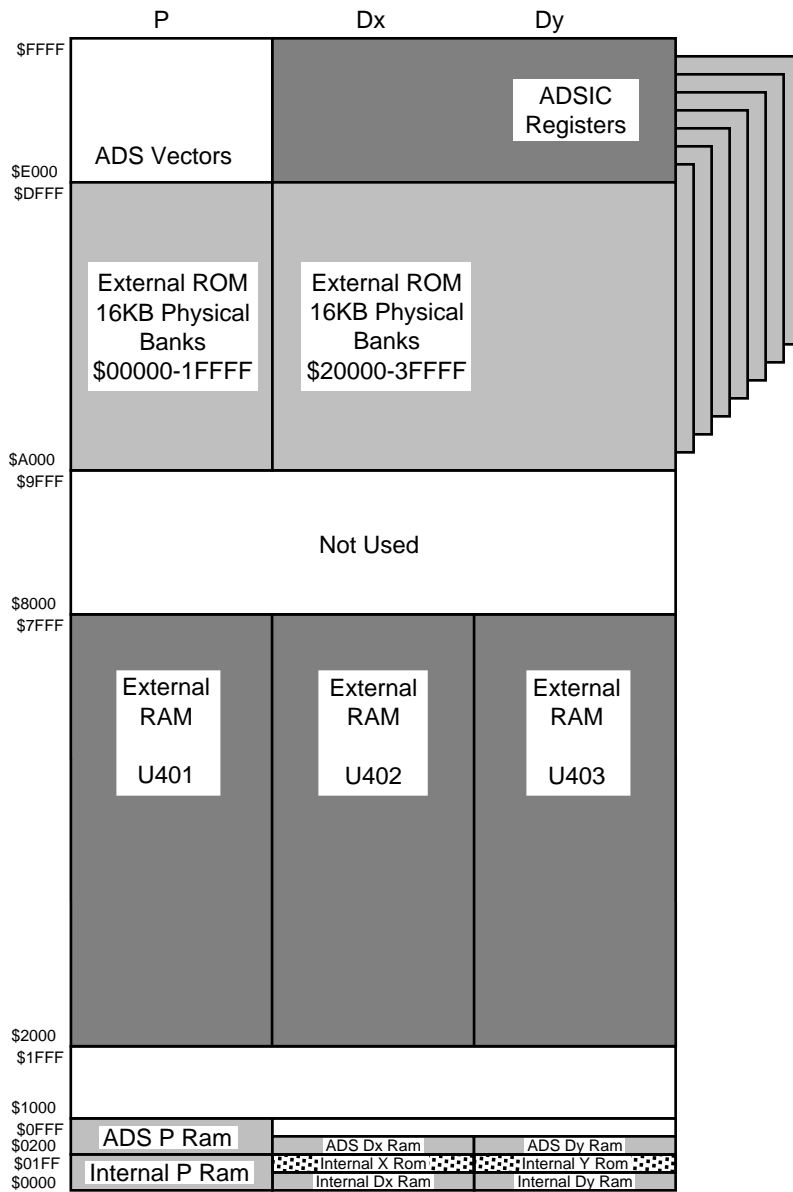

MAEPF-26007-A

Figure 3-13. Vocoder Memory Mapping

The ADSIC internal registers are decoded internally and start at \$E000 in Dy. These registers are decoded using A0-A2, A13-A15, and PS* from the DSP. The ADSIC internal registers are 16 bits wide, so only D8-D23 are used.

The DSP program code is stored in the FLASH ROM, U404. During normal modes of operation, the DSP moves the appropriate program code into the three SRAMs (U401, U402, and U403) and internal RAM for execution. The DSP never executes program code from the FLASH ROM itself. At power-up after reset, the DSP downloads 512 words (1536 bytes) from the ROM, starting at \$C000, and puts it into the internal RAM, starting at \$0000, where it is executed. This segment of program code contains the interrupt vectors and the reset vector, and is basically an expanded bootstrap code. When the MCU messages the DSP that the ADSIC has been configured, the DSP overlays more code from the ROM into external SRAM and begins to execute it. Overlays occur at different times when the DSP moves code from the ROM into external SRAM, depending on immediate mode of operation, such as changing from transmit to receive.

3.3.11 MCU System Clock

The MCU (U701) system clock is provided by circuitry internal to the MCU and is based on the crystal reference, Y100. The nominal operating frequency is 7.3728 MHz. This signal is available as a clock at 4XECLK on U701 and is provided to the SLIC (U702) for internal clock timing. The MCU actually operates at a clock rate of 1/4 the crystal reference frequency or 1.8432 MHz. This clock is available at ECLK on U701.

The MCU clock contains a crystal warp circuit comprised of L120, Q102, and C162. This circuit is controlled by an I/O port (PA6) on the MCU. This circuit moves the operating frequency of the oscillator about 250ppM on certain receive channels to prevent interference from the MCU bus noise.

3.3.12 DSP System Clock

The DSP (U405) system clock, DCLK, is provided by the ADSIC (U406). It is based off the crystal reference, Y401, with a nominal operating frequency of 33.0000 MHz. The ADSIC contains an internal clock-divider circuit that can divide the system clock from 33 MHz to 16.5 MHz or 8.25 MHz operation. The DSP controls this divider by writing to the ADSIC parallel registers. The frequency is determined by the processes the DSP is running and, to reduce system power consumption, is generally configured to the slowest operating speed possible.

The additional circuitry of CR402, L401, C416, C417, C419, and C422 make up a crystal warp circuit. This circuit is controlled by the OSCw signal from ADSIC, which is configured by the host through the SPI bus. The crystal warp circuit moves the operating frequency of the oscillator about 400ppM on certain receive channels to prevent interference from the DSP bus noise.

3.3.13 Radio Power-Up/Power-Down Sequence

Radio power-up begins when the user closes the radio on/off switch on the control top, placing 7.5 Vdc on the B+_SENSE line. This signal enables the pass element Q106 through Q105, enabling SW_B+ to the controller board and the transceiver board. B+_SENSE also enables the +5 Vdc regulator, U709. When +5 Vdc has been established, it is sensed by the supervisory IC, U726, which disables the system reset through the delay circuit R208 and C214.

When the MCU comes out of reset, it fetches the reset vector in ROM at \$FFFE, \$FFFF and begins to execute the code this vector points to. It configures the SLIC through the parallel bus registers. Among other things it enables the correct memory map for the MCU. It configures all the transceiver devices on the SPI bus. The MCU then pulls the ADSIC out of reset and, after a minimal delay, the DSP also. It then configures the ADSIC via the SPI bus, configuring, among other things, the DSP memory map. While this is happening, the DSP is fetching code from ROM U404 into internal RAM and beginning to execute it. It then waits for a message from the MCU that the ADSIC has been configured, before going on.

During this process, the MCU does power diagnostics. These diagnostics include verifying the MCU system RAM, and verifying the data stored in the internal EEPROM, external EEPROM, and FLASH ROMs. The MCU queries the DSP for proper status and the results of DSP self tests. The DSP self tests include testing the system RAM, verifying the program code in ROM U404, and returning the ADSIC configuration register checksum. Any failures cause the appropriate error codes to be sent to the display. If everything is OK, the appropriate radio state is configured and the unit waits for user input.

On power-down, the user opens the radio on/off switch, removing the B+_SENSE signal from the controller board. This does not immediately remove power, as the MCU holds this line active through B+_CNTL. The MCU then saves pertinent radio status data to the external EEPROM. Once this is done, B+_CNTL is released, shutting off SW_B+ at Q106 and shutting down the 5-Vdc regulator U709. When the regulator slumps to about 4.7 Vdc, supervisory IC U726 activates a system reset to the SLIC, which in turn resets the MCU.

3.3.14 VOCON Board Signals

Due to the nature of the schematic-generating program, signal names must be different when they are not *directly* connected to the same point. The following tables provide a cross-reference to the various pinouts for the same functional signal.

Table 3-2. VOCON Board Address Bus (A) Pinouts

Bus	U402	U403	U404	U405	U406	U414	U415
A0	A4	A4	20	C2	E9	A4	--
A1	B4	B4	19	D3	E10	B4	--
A2	A3	A3	18	D2	E8	A3	--
A3	B3	B3	17	E2	--	B3	--
A4	A2	A2	16	D4	--	A2	--
A5	B2	B2	15	B1	--	B2	--
A6	J6	J6	14	E3	--	J6	--
A7	K7	K7	13	F1	--	K7	--
A8	J7	J7	3	F2	--	J7	--
A9	K8	K8	2	F3	--	K8	--
A10	B8	B8	31	G1	--	B8	--
A11	A8	A8	1	J2	--	A8	--
A12	B7	B7	12	K1	--	B7	--
A13	J3	--	4	H3	D9	--	2
A14	--	--	5	G2	B9	--	1
A15	K3	K3	11	H2	D10	J3	--

Table 3-3. VOCON Board Address Bus (HA) Pinouts

Bus	U201	U202	U204	U205	U206	U210	U405
HA0	13	10	D2	20	D7	20	E9
HA1	11	9	C2	19	C7	19	F8
HA2	10	8	C1	18	C8	18	F9
HA3	8	7	D1	17	D8	17	--
HA4	2	6	E3	16	E6	16	--
HA5	7	5	E2	15	--	15	--
HA6	6	4	E1	14	--	14	--
HA7	5	3	E4	13	--	13	--
HA8	27	25	F1	3	F6	3	--
HA9	12	24	F3	2	F7	2	--
HA10	24	21	F2	31	--	31	--
HA11	26	23	G1	1	--	1	--
HA12	4	2	F4	12	--	12	--
HA13	28	26	G2	4	--	4	--
HA14	3	1	H1-In	5	H8-In H4-Out	5	--
HA15	--	--	H2-In	11	H7-In K3-Out	11	--
HA16	--	--	--	10	K6	10	--
HA17	--	--	--	6	G5	6	--

Table 3-4. VOCON Board Data Bus (D) Pinouts

Bus	U402	U403	U404	U405	U406	U414
D0	B9	B9	21	G3	--	B9
D1	C8	C8	22	J1	--	C8
D2	C9	C9	23	K3	--	C9
D3	D9	D9	25	L3	--	D9
D4	E8	E8	26	J3	--	E8
D5	E9	E9	27	K4	--	E9
D6	F9	F9	28	H4	--	F9
D7	G9	G9	29	L2	--	G9
D8	G8	G8	--	K2	H10	G8

Table 3-4. VOCON Board Data Bus (D) Pinouts (Continued)

Bus	U402	U403	U404	U405	U406	U414
D9	H8	H8	--	J4	H9	H8
D10	J9	J9	--	K5	H8	J9
D11	J8	J8	--	L5	J8	J8
D12	J2	J2	--	J5	L9	J2
D13	J1	J1	--	K6	K8	J1
D14	H2	H2	--	J6	L8	H2
D15	G2	G2	--	H7	J7	G2
D16	G1	G1	--	L9	K7	G1
D17	F1	F1	--	K8	L7	F1
D18	E1	E1	--	K7	J6	E1
D19	E2	E2	--	J7	K6	E2
D20	D1	D1	--	L8	J5	D1
D21	C1	C1	--	K10	L6	C1
D22	C2	C2	--	J9	L5	C2
D23	B1	B1	--	J10	K5	B1

Table 3-5. VOCON Board Data Bus (HD) Pinouts

Bus	U201	U202	U204	U205	U206	U210	U405
HD0	14	1	C6	21	C3	21	C7
HD1	15	12	B8	22	B1	22	B8
HD2	16	13	C7	23	C2	23	D7
HD3	18	15	D5	25	D4	25	A9
HD4	19	16	C8	26	C1	26	C9
HD5	20	17	D7	27	D2	27	C10
HD6	21	18	D6	28	D3	28	D8
HD7	23	19	D8	29	D1	29	C8

Table 3-6. U204 (MCU)

U204 Pin #	Description	To/From
B1	PE0	R260
B2	PE1 B SENSE/LBAT/PWR DWN	VR214
C3	PE2	N/C
A3	PE3 EMERG	J901-4
D3	PE4	N/C
A2	PE5	N/C
B3	PE6 SPKR COMMON	R263
C4	PE7 EXT SPKR	R261
B7	4XECLK (7.3726 MHz)	U206-A3
J7	PD0 BOOT DATA IN (RXD)	J501-17 U206
G6	PD1 BOOT DATA OUT (TXD)	J501-18 U208
H6	PD2 MISO	J801-7
J6	PD3 MOSI	J501-9 J801-8
G5	PD4 SPI SCK	J501-8 J801-9
H5	PD5 DA SEL*	J501-13
C5	MOD A	Q204C
B5	MOD B	Q204C
G3	PA0 SCLK	U405-C6 U406-C9
J2	PA1 BOOT MODE	U405
H3	PA2 HREQ*	U405-B10
J3	PA3 SB9600 BUSY	J501-20
G4	PA4 IRQA*	U406-F10 U405-H10
H4	PA5 BOOTSTRAP*	U206-E5
J4	PA6 ECLK SHIFT	Q205B
F5	PA7	N/C
E5	RESET/RESET*	U201-31 U206-E4
E6	PG7 CSPROG*	U206-E3
F8	PG6 CSGEN*	U211-1
G8	PG5 CS101*	U206-G1

Table 3-6. U204 (MCU) (Continued)

U204 Pin #	Description	To/From
G7	PG4 ADSIC RST*	U406-A8
F7	PG3 ADSIC SEL*	U406-B8
H8	PG2 DSP RST*	U405-G9
F6	PG1 ROSC/PSC CE*	J501-12
H7	PG0 SYN SEL*	J501-11
B6	R/W*	U405-D9 U206-B3
A5	ECLK (1.8432 MHz)	U206-A4
E8	XIRQ*	R233
E7	IRQ*	U206-E2
A6	EXTAL 7.3728 MHz	Y201
A7	XTAL	Q205C

Table 3-7. U206 (SLIC)

U206 Pin #	Description	To/From
F3	PH0	N/C
F4	PH1	N/C
F2	PH2	N/C
H1	PH3	N/C
G3	PH4	N/C
H2	PH5 INT PTT*	J501-30 U206-H2
H3	PH6 EMC REQ	J801-11
K2	PH7 LOCK DET*	J501-10 U302-41 CR502
B4	PJ0 MOB IRQ*	J501-26
D5	PJ1 VIP IN2	J501-25
A5	RS232 DATA OUT	J501-43
B6	PJ3 CTSOUT*	J501-5

Table 3-7. U206 (SLIC) (Continued)

U206 Pin #	Description	To/From
A6	PJ4	R268
C6	PJ5 OPT SEL2 (KEYLOAD*)	R237
A7	PJ6 VIP IN1	J501-24
D6	PJ7 EMC EN*	J801-10
C9	POR*	U409-2
E4	HC11RST*/RESET*	U204-E5 U201-31
C4	OE*	U201-25 U202-22 U205-32 U210-32
B3	R/W*	U405-D9 U204-B6
E5	BOOTSTRAP*	U204-H4
A2	MEM R/W*	U201-29 U202-27
E3	AV*/CSPROG*	U204-E6
G1	CE*/CS101*	U204-G8
G2	SCNSLB	R252
K5	ROM1CS*	U205-30
F5	ROM2CS*	U210-30
J4	EE1CS*	U201-22
J8	KEYFAIL *	J801-15 J501-21
B2	RS232 DATA IN	J501-50
J2	BOOT DATA IN	J501-17 U204- J7
A3	4XECLK	U204-B7
A4	ECLK	U204-A5
J3	VIP OUT2	J501-23
G4	SPKREN*	J501-44
K8	BUSY OUT*	J501-19
G9	TXPA EN*	J501-14
F8	5V EN*	J501-15

Table 3-7. U206 (SLIC) (Continued)

U206 Pin #	Description	To/From
G7	MICEN	J501-45
J9	B+ CNTL	U409-2 Q206B
E7	VIP OUT1	J501-22
K7	CS3B EMC MAKEUP*	J801-12
G6	CS2B RAM SEL*	U211-2
J7	CS1B HEN*	U405-E8
G8	DISP EN*/LATCH SEL*	J601-4
H9	RED LED	N/C
E8	GRN LED	N/C
E2	IRQ*	U204-E7

Table 3-8. VOCON U405 (DSP)

U405 Pin #	Description	To/From
C1	PS*	U404-6 U406-D8
C3	DS*	
A3	RD*	U404-32 U406-F8
C4	WR*	U404-7 U406-G10
B3	X/Y*	
A4	BR*	R411
B4	BG*/BS*	R432
H10	MODA/IRQA*	U204-G4 U406-F10
H9	MODB/IRQB*	U406-F9
J8	XTAL	R415
K9	EXTAL	U406-G9 (DCLK)
A2	STO	U406-H1
C5	SRO	U406-L3
B6	SCK	U406-G3
B2	SC2	U406-H2

Table 3-8. VOCON U405 (DSP) (Continued)

U405 Pin #	Description	To/From
B5	SC1	U406-J4
B9	SC0	U406-K4
C6	SCLK	U204-G3 U406-C9
A7	TXD/EMC RXD	J801-3
B7	RXD/EMC TXD	J801-4
G9	RESET/DSP RST*	U204-H8
E10	HACK*	R409
B19	HREQ*	U204-H3
E8	HEN*	U206-J7
D9	HR/W*	U204-B6

Table 3-9. VOCON U406 (ADSIC)

U406 Pin #	Description	To/From
D8	PS*	U404-6 U405-C1
G10	WR*	U405-C4 U404-7 U402/3/14-K2
F8	RD*	U405-A3 U404-32 U402/3/14-K6
J9	RSEL	U403-J3 U414-K3
G2	TP1	R407
G1	TP2	N/C
A4	AB1	R402
B8	SEL*/ADSIC SEL*	U204-F7
A8	RST*/ADSIC RST*	U204-G7
F10	IRQA/IRQA*	U204-G4 U405-H10
F9	IRQB/IRQB* 8 kHz	U405-H9

Table 3-9. VOCON U406 (ADSIC) (Continued)

U406 Pin #	Description	To/From
F2	SSW/EPS*	U404-30
C9	SCLK/SPI SCK	U204-G5 J501-8 J801-9
C10	SPO/MOSI	J501-9 J801-8
C1	MA1	U501-39
B5	SDO	U501-40
B1	VRO REFMOD	J501-48
B2	MODIN	J501-49
L3	RXD SRO 2.4 MHz	U405-C5
J4	RFS SC1	U405-B5
K4	SCKR SCO	U405-B9
H1	TXD STO	U405-A2
H2	TFS SC2 48 kHz	U405-B2
G3	SCKT SCK 1.2 MHz	U405-B6
C8	DA4 BNK2	U404-10
C3	DA7B BNK1	U404-11
B6	DA7A BNK0	U404-5
J1		N/C
J2		N/C
K1		N/C
K2		N/C
H3	DIN*/DOUT*	J501-1
K3	DIN/DOUT	J501-2
F3	IDC ODC 2.4 MHz	J501-7
J3	SBI	J501-6
C7	XTL 33 MHz	Y401
C6	EXTL	Y401
K9	OSC*	CR402
G9	DCLK	U405-K9

3.4 ASTRO Spectra Plus VOCON Board

This section of the theory of operation provides a detailed circuit description of an ASTRO Digital Spectra Plus Vocoder/Controller (VOCON) board. When reading the Theory of Operation, refer to your appropriate schematic and component location diagrams located in [“Chapter 7. Schematics, Component Location Diagrams and Parts Lists”](#) of this manual. This detailed Theory of Operation will help isolate the problem to a particular component. However, first use the *ASTRO Digital Spectra and Digital Spectra Plus Mobile Radios Basic Service Manual* to troubleshoot the problem to a particular board.

NOTE: The information in this subsection applies to the **Plus** VOCON board. Refer to Section [3.3, “ASTRO Spectra VOCON Board,”](#) on page 3-15 for information on the ASTRO Spectra VOCON (non Plus) board.

3.4.1 General

The ASTRO Spectra Plus VOCON board consists of two subsystems; the vocoder and the controller. Although these two subsystems share the same printed circuit board and work closely together, it helps to keep their individual functionality separate in describing the operation of the radio. The controller section is the central interface between the various subsystems of the radio. It is very similar to the digital logic portion of the controllers on many existing Motorola radios. Its main task is to interpret user input, provide user feedback, and schedule events in the radio operation, which includes programming ICs (Integrated Circuits), steering the activities of the DSP (Digital Signal Processor), and sending messages to the display through the control head. The vocoder section performs functions previously performed by analog circuitry. This includes all tone signaling, trunking signaling, and conventional analog voice, etc. All analog signal processing is done digitally utilizing a DSP56600. In addition it provides a digital voice plus data capability utilizing IMBE voice compression algorithms. Vocoder is a general term used to refer to these DSP based systems and is short for voice encoder. In addition, the ASTRO Spectra Plus VOCON board provides the interconnection between the MCU (microcontroller unit), DSP, command board, and UCM (Universal Encryption Module) on secure-equipped radios.

3.4.2 ASTRO Spectra Plus Controller Section

Refer to [Figure 3-14 on page 3-39](#) and your specific schematic diagram located in Chapter 7.

The controller section of the ASTRO Spectra Plus VOCON board consists entirely of digital logic comprised of a microcontroller unit core (Patriot IC-U300), and memory consisting of: SRAM (U302), and FLASH ROM (U301). The Patriot IC is a dual-core processor that contains a DSP56600 core, a MCore 210 microcontroller core and custom peripherals. Note: When the Controller Section references the MCU, it will be referencing the Mcore 210 inside the Patriot IC (U300).

The MCU (U300) memory system is comprised of a 256k x 16 SRAM (U302) and a 2M x 16 FLASH ROM (U301). The MCU also contains 22.5k x 32 of internal SRAM. The FLASH ROM contains the programs that the Patriot IC executes, and is used to store customer specific information and radio personality features (i.e. codeplug information). The FLASH ROM allows the controller firmware to be reprogrammed for future software upgrades or feature enhancements. The SRAM is used for scratchpad memory during program execution.

The controller performs the programming of all peripheral ICs. This is done via a serial peripheral interface (SPI) bus, and through General Purpose Input/Outputs (GPIO) from the Patriot IC. ICs programmed through these interfaces include the Synthesizer, Prescaler, DAIC, and KRSIC (U200) and ADDAG (U201).

In addition to the SPI bus, the controller also maintains two asynchronous serial busses; the SB9600 bus and an RS232 serial bus. The SB9600 bus is for interfacing the controller section to different hardware option boards, some of which may be external to the radio. The RS232 is used as a common data interface for external devices.

User input from the control head is sent to the controller through SB9600 bus messages. Feedback to the user is provided by the display on the control head. The display is 2-line 14 characters on the W3 model, 8 characters on W4, W5, and W7 models; and 11 characters on the W9 model.

The controller schedules the activities of the DSP through the host port interface, which is internal to the Patriot IC (the MCU and DSP are both contained within the Patriot IC). This includes setting the operational modes and parameters of the DSP. The controlling of the DSP is similar to programming analog signaling ICs on standard analog radios.

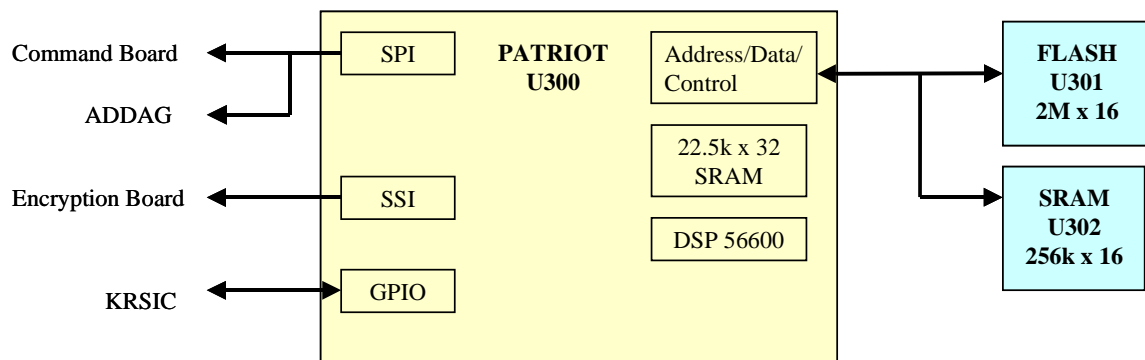

Figure 3-14. ASTRO Spectra Plus VOCON Board - Controller Section

3.4.3 ASTRO Spectra Plus Vocoder Section

Refer to [Figure 3-15 on page 3-40](#) and your specific schematic diagram in Chapter 7.

The vocoder section of the ASTRO Spectra Plus VOCON board is made up of a digital signal processor (DSP) core, 84Kx24 Program RAM, 2Kx24 Program ROM, and 62Kx16 Data RAM, which are all integrated into the Patriot IC (U300). The vocoder also contains the KRSIC (U200) and ADDAG (U201).

The FLASH ROM (U301) contains both the program code executed by the DSP and the controller firmware. As with the FLASH ROM used in the controller section, the FLASH ROM is reprogrammable so new features and algorithms can be updated in the field as they become available. Depending on the mode and operation of the DSP, corresponding program code is moved from the FLASH ROM into the faster SRAM, where it is executed at the full bus rate.

The KRSIC and ADDAG IC's are the support IC's for the DSP. In the receive mode, the KRSIC (U200) acts as an interface to the ABACUS IC, which can provide data samples directly to the DSP for processing. In the transmit mode, the ADDAG (U201) provides a serial digital-to-analog (D/A) converter. The ADDAG (U201) also has a function in receive mode for special applications. The data generated by the DSP is filtered and reconstructed as an analog signal to present a modulation signal to the VCO (voltage-controlled oscillator). Both the transmit and receive data paths between the DSP and ADDAG are through the DSP SSI port.

When transmitting, the microphone audio is passed from the command board to the MC145483 CODEC (U402), which incorporates an analog-to-digital (A/D) converter to translate the analog waveform to a data stream. The data is made available to the DSP through the Serial Audio Port (SAP) of the Patriot IC. In the converse way, the DSP writes speaker data samples to a D/A in the CODEC (U402) through the SAP. The CODEC (U402) provides an analog speaker audio signal to the audio power amplifier on the command board.

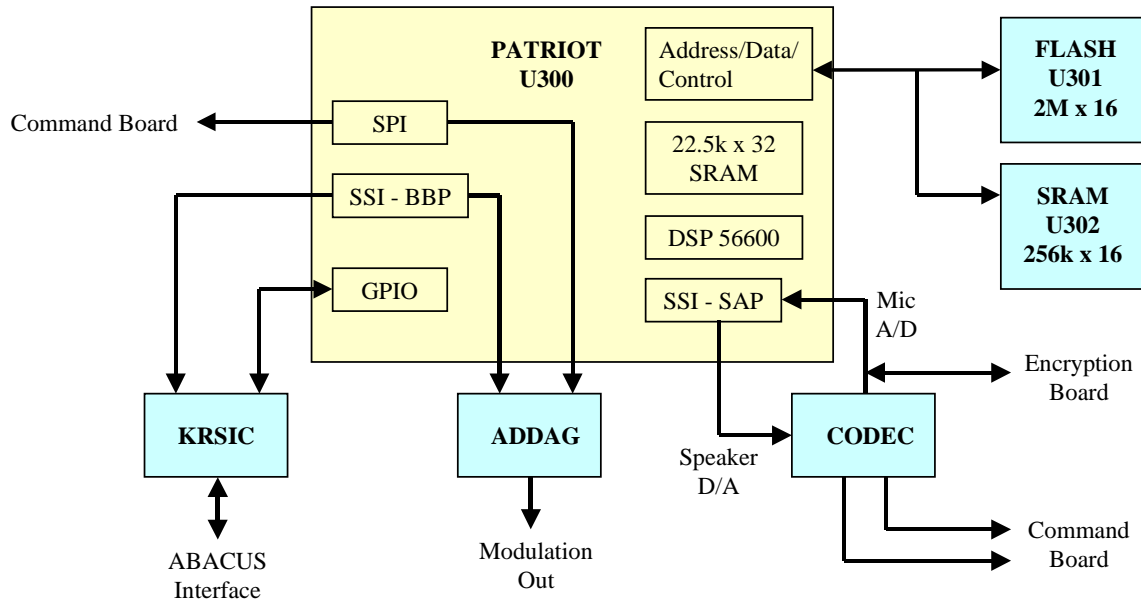

Figure 3-15. ASTRO Spectra Plus VOCON Board - Vocoder Section

3.4.4 ASTRO Spectra Plus RX Signal Path

The vocoder processes all received signals digitally. This requires a unique back end from a standard analog radio. This unique functionality is provided by the ABACUS IC with the KRSIC (U200) acting as the interface to the DSP. The ABACUS IC located on the transceiver board provides a digital back-end for the receiver section. It provides a digital output of I (In phase) and Q (Quadrature) data words at a 20 kHz sampling rate (refer to the Receiver Back-End section for more details on ABACUS operation). This data is passed to the DSP through an interface with the KRSIC (U200) for appropriate processing. The KRSIC interface to the ABACUS is comprised of the four signals SBI, DIN, DIN*, and ODC (refer to [Figure 3-16](#)).

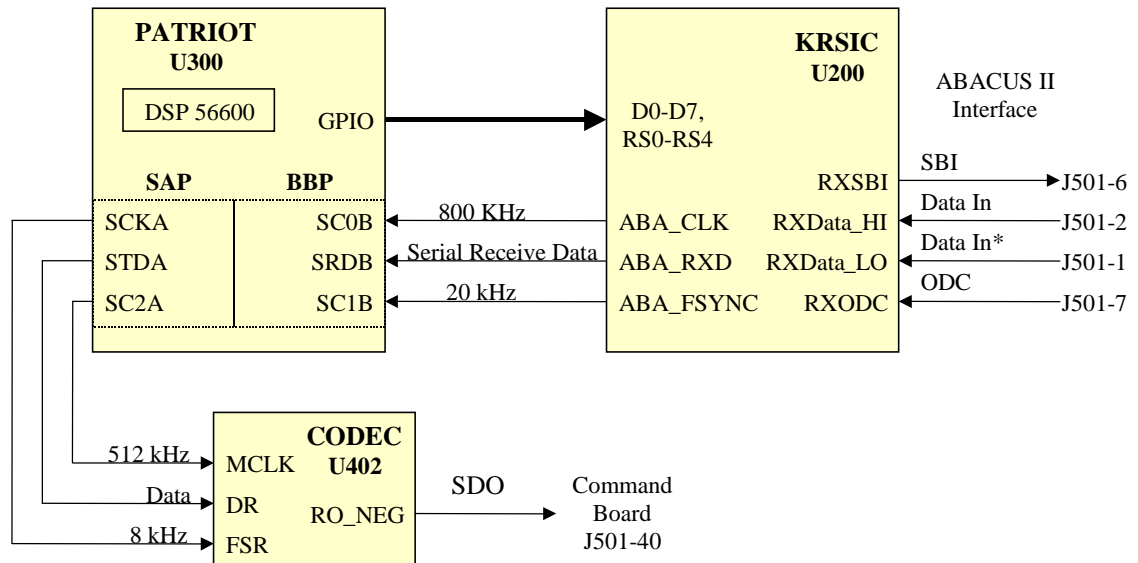

Figure 3-16. ASTRO Spectra Plus RX Signal Path

NOTE: An asterisk symbol (*) next to a signal name indicates a negative or NOT logic true signal.

ODC is a clock ABACUS provides to the KRSIC. Most internal KRSIC functions are clocked by this ODC signal at a rate of 2.4 MHz and is available as soon as power is supplied to the circuitry. This signal may initially be 2.4 or 4.8 MHz after power-up. It is programmed by the KRSIC through the SBI signal to 2.4 MHz when the KRSIC is initialized by the MCU (in the Patriot IC) through GPIO. SBI is a programming data line for the ABACUS. This line is used to configure the operation of the ABACUS and is driven by the KRSIC. The MCU programs many of the KRSIC operational features through the GPIO interface. When the KRSIC is programmed properly by the MCU, the KRSIC in turn sends this data to the ABACUS through the SBI.

DIN and DIN* are the data lines on which the I and Q data words are transferred from the ABACUS. These signals make up a differentially encoded current loop. Instead of sending TTL type voltage signals, the data is transferred by flowing current one way or the other through the loop. This helps to reduce internally generated spurious emissions on the RF board. There are single-ended driver circuits between the ABACUS and the KRSIC, which are used to convert the differential current driven by the ABACUS. After the driver circuits, the I and Q samples are detected and transferred to a serial transmitter.

The DSP accesses this data through its SSI port. The SSI port is used by the DSP for both transmit and receive data transferal, but only the receive functions will be discussed in this section. The KRSIC transfers the data to the DSP on the SRDB line at a rate of 1.2 MHz. This is clocked synchronously by the KRSIC which provides a 1.2 MHz clock on SC0B. In addition, a 20 kHz interrupt is provided on SC1B, signaling the arrival of a data packet. This means the I and Q sample data packets are available to the DSP at a 20 kHz rate which represents the sampling rate of the received data. The DSP then processes this data to extract audio, signaling, etc. based on the 20 kHz interrupt.

Speaker audio is processed by the DSP (in the Patriot IC), which outputs the audio data words to the speaker D/A inside the CODEC (U402), and an analog waveform is generated on the SDO (Speaker Data Out) line. In conjunction with the speaker D/A, the CODEC (U402) has the ability to attenuate the receive analog output, using three data bits which provide programmable attenuation to set the rough signal attenuation.

For secure messages, the digital signal data must be passed to the secure module for decryption prior to DSP processing of the speaker data. The DSP transfers the data to and from the secure module through its SSI port consisting of TXD and RXD. The secure module communicates with the DSP through its SPI bus, therefore a SSI to SPI conversion circuit is on the ASTRO Spectra Plus VOCON board to ensure communication between the DSP and the secure module. Configuration and mode control of the secure module is performed by the MCU through the SSI/SPI bus.

The CODEC presents the analog speaker audio to the command board's audio power amplifier, which drives the external speaker. For more information on this subject, refer to Section 3.2, "Command Board," on page 3-8.

Since all of the audio and signaling is processed in DSP software algorithms, all types of audio and signaling follow this same path. There is, however, one exception. Low-speed trunking data is processed by the host uP through the SCLK port of the DSP. The DSP extracts the low-speed data from the received signal and relays it to the host uP for processing.

3.4.5 ASTRO Spectra Plus TX Signal Path

The transmit signal path (refer to Figure 3-17) follows some of the same design structure as the receive signal path described in Section 3.4.4, "ASTRO Spectra Plus RX Signal Path," on page 3-41.

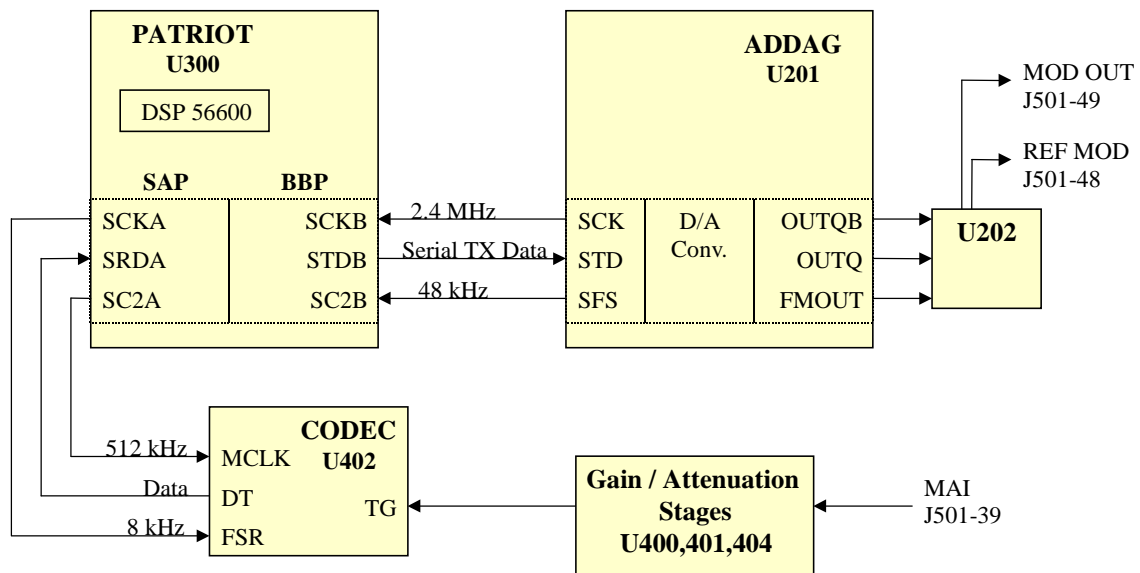

Figure 3-17. ASTRO Spectra Plus TX Signal Path

The analog microphone signal from the command board is passed to the ASTRO Spectra Plus VOCON on MAI (Mic Audio In). This signal passes through gain and attenuation stages so that the correct amplitude level of the audio is presented to the CODEC input. The CODEC contains a microphone A/D. The microphone A/D converts the analog signal to a digital data stream and transmits them to the SAP of the Patriot IC. The DSP accesses this data through this port. As with the speaker data samples, the DSP reads the microphone samples from registers mapped into its memory space.

As with the received trunking low-speed data, low speed transmit data is processed by the MCU and returned to the DSP. For secure messages, the digital signal data may be passed to the secure module prior to DSP processing before the ADDAG IC. The DSP transfers the data to and from the secure module through its SSI port consisting of TXD and RXD. The secure module communicates with the DSP through its SPI bus, therefore a SSI to SPI conversion circuit is on the ASTRO Spectra Plus VOCON board to ensure communication between the DSP and the secure module. Configuration and mode control of the secure module is performed by the MCU through the SSI / SPI bus.

The DSP processes these microphone samples, generates and mixes the appropriate signaling, and filters the resultant data. This data is then transferred to the ADDAG IC on the DSP BBP (Baseband Port) - SSI port. The transmit side of the SSI port consists of SC2B, SCKB, and STDB. The DSP BBP-SSI port is a synchronous serial port. SCKB is the 2.4 MHz clock input derived from the ADDAG, which makes it synchronous. The data is clocked over to the ADDAG on STDB at a 2.4 MHz rate. The ADDAG generates a 48 kHz interrupt on SC2B so that a new sample data packet is transferred at a 48 kHz rate, which sets the transmit data sampling rate at 48Ksp.

Within the ADDAG IC, these samples are then input to a transmit D/A, which converts the data to an analog waveform. This waveform is the modulation out signal from the ADDAG ports, FMOUT, OUTQ, and OUTQB. FMOUT is single-ended, while OUTQ and OUTQB form a differential pair. This pair is then sent to an Op-Amp (U202), which outputs a single-ended waveform. FMOUT is passed through an Op-Amp (U202) for attenuation. These signals are both sent to the command board, where they go through a gain stage and then to the VCO and Synthesizer. MODOUT is used primarily for audio frequency modulation; REFMOD is used to compensate for low-frequency response to pass subaudible modulated signals (such as PL).

3.4.6 ASTRO Spectra Plus Controller Bootstrap and Asynchronous Busses

The SB9600 bus (see [Figure 3-18 on page 3-44](#)) is an asynchronous serial communication bus, utilizing a Motorola proprietary protocol. It provides a means for the MCU to communicate with other hardware devices. In the ASTRO Digital Spectra Plus radio, it communicates with hardware accessories connected to the accessory connector and the remote interface board.

The SB9600 bus utilizes the UART internal to the MCU, operating at 9600 baud. The SB9600 bus consists of LH / TX_Data (J501-18), LH / RX_Data (J501-17), and BUSY_RTS (J501-20) signals. LH / TX_Data and LH / RX_Data are the UTXD1 (K11) and URXD1 (K12) ports of the Patriot IC (U300), respectively. BUSY_RTS (U300-URTS1- L16) is an active-low signal, which is pulled low when a device wants control of the bus.

The same UART internal to the MCU is used in the controller bootstrap mode of operation. This mode is used primarily in downloading new program code to the FLASH ROM (U301) on the VOCON board. In this mode, the MCU accepts special code downloaded at 115k baud through the UART instead of operating from program code resident in its ROMs.

A voltage greater than 11 Vdc applied to J501-31 (Vpp) will trip the circuit comprising VR304, Q300, and U307. This circuit sets the MOD pin (J1) of the MCU to bootstrap mode (logic 1). A voltage greater than 7 Vdc applied to J501-31 (Vpp) will trip the circuit comprising VR305 and Q302. This will not put the MCU in Bootstrap mode, but the software will detect this using pin PA7 (G11), which will allow the user to interface with the Customer Programming Software, Tuner, and Flashport.

The ASTRO Digital Spectra Plus radio has an additional asynchronous serial bus, which utilizes the RS232 bus protocol. This bus utilizes the secondary UART in the Patriot IC (U300). It consists of TX / RS232 (J501-43), RX / RS232 (J501-50), CTS / RS232 (J501-5), and RTS / RS232 (J501-42). It is a four-wire duplex bus used to connect to external data devices.

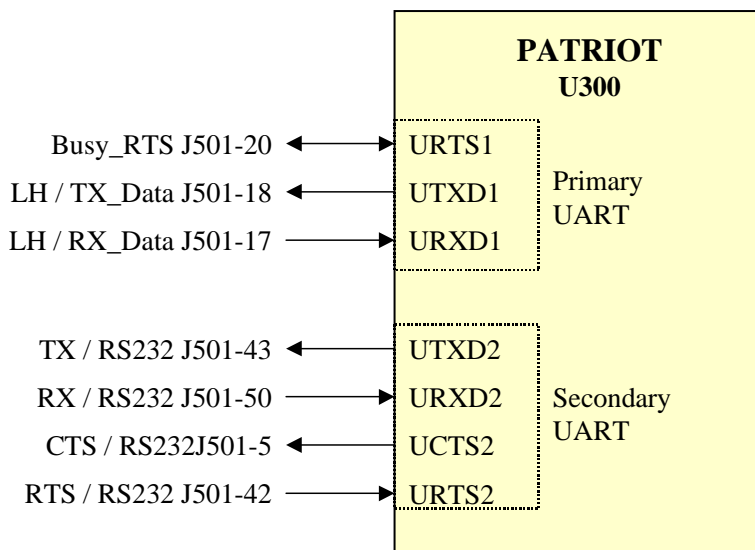

Figure 3-18. ASTRO Spectra Plus Host SB9600 and RS232 Ports

3.4.7 ASTRO Spectra Plus Serial Peripheral Interface Bus

This bus is a synchronous serial bus made up of a data, a clock, and an individual IC unique select line. Its primary purpose is to configure the operating state of each IC. ICs programmed by this include: ADDAG, Synthesizer, Prescaler, and the DAIC.

The MCU within the Patriot IC (U300) is configured as the master of the bus. It provides the synchronous clock (SPI_SCK), a select line, and data (MOSI [Master Out Slave In]). In general the appropriate select line is pulled low to enable the target IC and the data is clocked in. The SPI bus is a duplex bus with the return data being clocked in on MISO (Master In Slave Out). The only place this is used is when communicating with the ADDAG. In this case, the return data is clocked back to the MCU on MISO (master in slave out).

3.4.8 ASTRO Spectra Plus MCU and DSP System Clocks

The MCU within the Patriot IC (U300) needs two clocks for proper operation. A 16.8 MHz sine-wave reference is provided at the CKIH (A6) pin of the Patriot IC (U300). The source of this clock is a 16.8 MHz oscillator (Y400), and its associated filtering circuitry. This clock is also provided to the KRSIC (U200), and the ADDAG IC (U201). The MCU has the capability of running at higher clock rates, which are programmable and based on this 16.8 MHz reference. The DSP within the Patriot IC (U300) also uses the 16.8 MHz provided at the CKIH (A6) pin as a reference.

The Patriot IC (U300) also requires a 32 kHz square-wave clock, provided at the CKIL (J7) pin. This clock is generated by a 32 kHz crystal (Y401), with supporting circuitry for oscillation. This clock is utilized only for the Patriot IC (U300), and is used for reset capability and other Patriot IC (U300) functions.

3.4.9 ASTRO Spectra Plus Voltage Regulators

The ASTRO Spectra Plus VOCON board contains two voltage regulators, a 3-V regulator (U411) and a 1.8-V regulator (U410). SW+5-V, which is routed to the ASTRO Spectra Plus VOCON board from the command board, drives the two regulators. Figure 3-19 shows the DC distribution for the ASTRO Spectra Plus VOCON board.

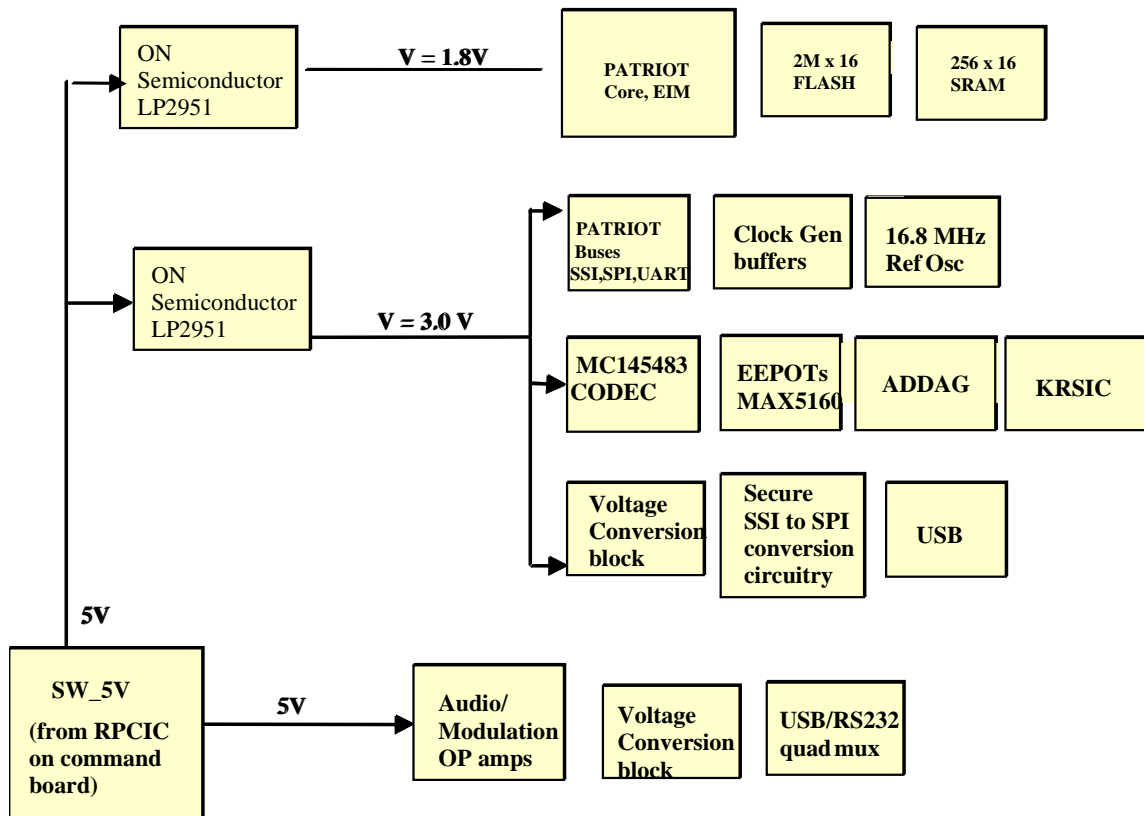

Figure 3-19. ASTRO Spectra Plus VOCON DC Distribution

U410 and U411 are on Semiconductor LP2951CD adjustable regulators. The output voltage of these regulators is determined by the resistive divider network between the regulator output and the error amplifier feedback input. The LP2951 has error output lines which are open collector and requires a pull up resistor (R332). The error line is high when the output voltage is high and low otherwise. U412 is a 4.2-V detect circuit for the SW_5-V line. The output of this detector is tied to the error outputs of the LP2951 regulators as a low voltage detect (LV_detect) circuit. C438 provides delay on the LV_detect line during startup. This is to allow all regulators to settle prior to Patriot U300 coming out of reset.

3.4.10 ASTRO Spectra Plus Radio Power-Up/Power-Down Sequence

The radio power-up sequence begins when the user actuates the control head's on/off switch. The control head then produces the switched B+ (SWB+) output voltage which is routed to the command board. Upon sensing the SWB+ voltage, the command board circuitry powers on the 9.6V and the SW +5-V regulated supplies. The ASTRO Spectra Plus VOCON board contains two voltage regulators, a 3-V regulator (U411) and a 1.8-V regulator (U410). The SW+5-V from the command board is routed to the ASTRO Spectra Plus VOCON board via connector P501, and drives the two regulators. When SW+5-V increases above 4.2 V and after a delay time chosen by C438, the voltage detector (U412) disables the power-on reset to the Patriot IC (U300), enabling the device.

When the MCU comes out of reset, it fetches the reset vector in ROM at \$FFFE, \$FFFF and begins to execute the code this vector points to. Among other things it enables the correct memory map for the MCU. It configures all the transceiver devices on the SPI bus. The MCU then pulls the ADDAG and KRSIC out of reset. It then configures the ADDAG through the SPI bus configuring among other things, the DSP memory map. While this is happening, the DSP is fetching code from the FLASH (U301) into internal RAM and beginning to execute it. It then waits for a message from the MCU that the ADDAG has been configured, before going on.

During this process, the MCU does power diagnostics. These diagnostics include verifying the MCU system RAM and verifying the data stored in the FLASH ROM. The MCU queries the DSP for proper status and the results of DSP self tests. The DSP self tests include testing the system RAM and verifying the program code. Any failures cause the appropriate error codes to be sent to the display. If everything is OK, the appropriate radio state is configured and the unit waits for user input.

On power-down, the user actuates the radio's on/off switch, removing the SW_B+ signal from the ASTRO Spectra Plus VOCON board. The host processor, after polling ROW3 (G2) and acknowledging the signal loss, begins the power-down sequence. Since the host holds the 9.6-V/5V_EN (enable) line active by controlling the state of the ROW5 / 5_EN line at P501, pin 15, this does not immediately remove power. The host then saves pertinent radio status data to the external FLASH (U301). Once this is done, the ROW5 / 5V_EN line is released (brought to logical 1), turning off 9.6-V and the SW+5-V regulators on the command board. When the SW_+5-V slumps to about 4.2 Vdc, the voltage detector (U412) on the ASTRO Spectra Plus VOCON board activates the system reset to the Patriot IC (U300). This turns off the host processor.

3.5 Voltage Control Oscillator

This section of the theory of operation provides a detailed circuit description of voltage control oscillator (VCO). When reading the Theory of Operation, refer to your appropriate schematic and component location diagrams located in "[Chapter 7. Schematics, Component Location Diagrams and Parts Lists](#)". This detailed Theory of Operation will help isolate the problem to a particular component. However, first use the *ASTRO Digital Spectra and Digital Spectra Plus Mobile Radios Basic Service Manual* to troubleshoot the problem to a particular board.

3.5.1 VHF Band

3.5.1.1 General

The frequency injection string consists of a voltage-controlled oscillator (VCO) constructed on a ceramic substrate and amplifier and divider stages located on the PC board. The components associated with the PC board may be repaired by conventional methods while the VCO substrate should be replaced as a unit.

3.5.1.2 DC Voltage Supplies

The 9.6-V supply enters the VCO carrier board at P601-2. It powers the receiver amplifier (Q675) and its associated biasing components. The keyed 9.4-V supply enters the carrier board at J601-5, but only during the transmit mode. K9.4 powers the divider (Q681), and the buffer amplifiers (Q682, Q683). The 8.6-V supply enters through P601-12 and passes to MP652, MP653, and MP654 on the VCO substrate. The 8.6 V supplies the output buffer on the VCO substrate, and supplies Q642 and 0643, the PIN diode drivers.

3.5.1.3 VCO

The VCO utilizes a common-gate FET in a Colpitts configuration as the gain device. The LC tank circuit's capacitive portion consists of a varactor bank and a laser-trimmed stub capacitor. The inductive portion consists of microstrip transmission-line resonators. The stub capacitor serves to tune out build variations. Tuning is performed at the factory and is not field adjustable. The varactor network changes the oscillator frequency when the DC voltage of the steering line changes. The microstrip transmission lines are shifted in and out of the tank by PIN diodes for coarse frequency jumps. The varactor bank consists of CR644 CR645 and L648. The positive steering line connects to the cathodes of both varactors through L3647, an RF choke. This line is normally between 0.5 and 8.5 Vdc, depending on the frequency programmed in the synthesizer. The negative steering line connects to the anodes of the varactors through L646 and is normally 3.9 (± 0.3) Vdc.

Diode CR643, a third varactor tapped into the main transmission line resonator, modulates the oscillator during transmit. The 8.6 Vdc supplies bias to the cathode. Modulation is coupled to the anode through C639, R636, C636, and R3637, which also provide filtering and attenuation to the modulation path.

Components CR646, C668, and R655 provide automatic gain control for the FET. A hot carrier diode, CR3646, detects the peak RF voltage swings on the source of the FET. A negative voltage, proportional to the magnitude of the RF voltage swing, is applied to the gate of the FET, thereby lowering its gain and accomplishing automatic gain control. Typical DC value of the gate bias is -0.8 to -1.7 V, depending on the state of the oscillator.

PIN diodes, CR640, CR641, and CR642, serve to couple secondary transmission lines into and out of the main oscillator tank, depending on which range the VCO is operating. AUX 1* controls CR642 and CR643; AUX 2* controls CR3640. When AUX 1* goes high, Q643 turns off and a reverse-bias voltage of about 8.6 Vdc is applied to the PIN diodes to turn them off. When AUX1* goes low, Q643 turns on and a forward-bias current of about 15mA is supplied to the PIN diodes to turn them on. The other PIN diode driver network operates similarly.

The VCO output is coupled through C672 to Q645 to amplify the signal and provide load isolation for the VCO. The collector voltage of Q645 is normally about 5 Vdc.

3.5.1.4 Synthesizer Feedback

The synthesizer locks the VCO on frequency by the VCO feedback to the prescaler IC on the RF board. The output of the VCO goes into a low-pass filter consisting of C685, L676, and C687. After it is filtered, the signal splits into three directions - the majority of which passes to the RX buffer through a 2db attenuator. A smaller portion of the signal passes through C679 to the divider. Finally, another small portion of the signal is fed back to the RF board through C676 to P601 -1. Although on a DC connector, P601 -1 is an RF-sensitive node. To measure the synthesizer feedback power, use a high-impedance probe, or operate the VCO in an external fixture.

3.5.1.5 RX Buffer Circuitry

After the low-pass filtering stage, VCO power is attenuated 2dB by R678, R680, and R679. The RX buffer is a 50-ohm in-and-out stage that uses L681 and C689 for the input match and C691, L678, C692, and R699 for the output match. The 9.6 Vdc supplies the RX buffer for a gain of about 10db. Components R677 and C686 help to filter out some of the 9.6-V supply's noise from the RX buffer. Transistors Q677, Q678, and associated resistors set the bias level of the RX buffer device, Q675. The collector voltage and current should be near 6.6 V and 29 mA, respectively. Resistor R682 feeds the base of Q675 while L677 is used as the collector choke; R681, C690, and C688 are added to increase stability. The cable from the RX frontend is plugged into J642.

3.5.1.6 Frequency Divider and TX Buffer Circuitry

During transmit, the VCO oscillates at twice the transmit frequency. A frequency-divider circuit following the VCO buffer divides the VCO's output frequency by two. The circuit is known as a "regenerative frequency divider" in which a mixer and a feedback amplifier are used to divide the frequency of the input signal. The divider circuit consists of transformers T601 and T602, diodes CR601, CR602, amplifier Q681, and the associated bias circuitry. The divider action of this circuit can be understood by tracing the signal through the circuit as follows: The 300 MHz range signal from the VCO buffer is fed into the primary of T602. Note that T602, T601, and diodes CR601 and CR602 form a balanced mixer. (CR601 and CR602 are actually two diodes in one SOT-23 package.) To analyze the frequency division action of the circuit, it must be assumed that the divided output frequency of 150 MHz already exists at the secondary of T601. This 150 MHz signal passes through the low-pass filter consisting of L661, L662, and C651. The 150 MHz signal is now at the input of the amplifier device, Q681. The amplified 150 MHz signal is now applied back into the balanced mixer by the center tap of T601. The difference frequency of the two applied signals (300 MHz and 150 MHz) is 150 MHz, which is half the VCO's frequency. The difference frequency is output through the secondary of T601 where it had been previously assumed to exist. This completes the feedback loop.

The 150 MHz signal is tapped off of the emitter resistor of Q681 and is amplified by the buffer stage, Q682. Transistor Q683 amplifies the signal to 10dBm, which is the level required by the power amplifier. The signal passes through a low-pass filter before exiting the board through J641.

3.5.2 UHF Band

3.5.2.1 General

The VCO is located on an alumina substrate with a metallic cover. The buffer-doubler-buffer section is located on the PC board and may be repaired using normal repair methods.

3.5.2.2 Super Filter 8.6 V

Super-filtered 8.6 V enters the carrier board at J601-12, through an R-C filter, then on to the drain of Q9610 and the collector of Q9635.

3.5.2.3 VCO

The oscillator consists of Q9610, the main transmission line (T-line), varactor bank (CR9616-9617, C9616-9617, L9616) and feedback capacitors (C9611-9613). Components CR9610, C9614, and R9613 form an AGC circuit to prevent breakdown of the FET. Components CR9626 and C9626 form a bandshift circuit to shift the oscillator frequency up 50 MHz; C9630-9631 and CR9630 form the Receive shift circuit which shifts the VCO up 50 MHz. The main modulation circuit consists of C9621 and CR9621 in conjunction with the deviation compensating capacitors (C9622 and C9623). Finally, transistor (Q9635), resistors (R9635-9639), and capacitors (C9635-9636, C9638) form the output buffer.

This VCO utilizes both a positive and negative steering line. The SL- should be -4.0 V (± 3 V) at all times. The SL+ will range from 1 to 8 V, depending on frequency and AUX bits.

3.5.2.4 Receive Mode (AUX2* Low)

When AUX2* input is low, the receive pin diode, CR9630, is forward biased by 8.6-V supply thru Q5650 and R5652. This current is then sunk into the RF board thru R5654. At this time the voltage divider output of R5649, R5651, and R5653 will keep Q5651 turned off.

3.5.2.5 Transmit Mode (AUX2* High)

When AUX2* is high (8.4 V), Q5650 will be off and Q5651 will be on. This puts -8 V on the anode of CR9630 and +8.4 V on its cathode. With approximately 16-V reverse bias on the diode, the receive bandshift T-line is removed from the circuit.

3.5.2.6 Bandshift Circuit

R9625, C9625, L9628, and C9628 form a bandshift circuit which shifts the frequency of the oscillator slightly. There is one bandshift in receive and one in transmit. The circuitry works similar to the receive pin circuitry but with the cathode of CR9626 returned to ground. This results in a maximum of 8-V reverse bias on this diode.

3.5.2.7 Output Buffer

Transistor (Q9635), resistors (R9635-9639), and capacitors (C9635-9636, C9638) form a simple common-emitter buffer to provide isolation to the VCO and an output power of +10 dBm.

3.5.2.8 First Buffer

The VCO output is coupled to the first buffer via blocking capacitor (C5661), resistive pads (R5661 and R5662), and a high-pass filter (L5660 and C5662). Q5660 is a self-biased, common-emitter amplifier which provides approximately + 10 dBm drive to the doubler as well as reverse isolation to the VCO.

3.5.2.9 Doubler

The first buffer output is coupled to the input of the doubler by C5663. Q5660 doubles the drive frequency and increases power by approximately 3 dB as a result of the high and low impedances presented to its collector at the doubled frequency and drive frequency, respectively. The collector impedances are presented by an elliptical high-pass filter (C5670-C5674, L5670, and L5671). The filter is terminated in a resistive pad (R5676-R5678) which also serves to terminate one end of the elliptical low-pass filter (C5675, C5677, and L5672-L5674). In addition to filtering, the low-pass filter provides part of the impedance match required between the resistive pad and the second buffer. The remaining impedance match is accomplished with L5680 and C5680, configured to provide additional high-pass selectivity.

3.5.2.10 Synthesizer Feedback

The base of Q5680 provides the tap location for the synthesizer feedback buffer. C5685-C5686 and L5681 provide low-pass filtering. R5630, R5631 and R5632 is a resistive pad. Q5630 provides approximately -5 dBm to the RF board.

3.5.2.11 Second Buffer

The second buffer, Q5680, is a common-emitter amplifier with approximately 12 dB gain. It is biased to 40 mA. with an active current source, Q5681 and R5580-R5587, which ensures saturated operation.

3.5.2.12 Receive/Transmit Switch

In the receive mode where K9.4-V is off, Q5640 conducts current to turn on the part of CR5690 (a dual-common cathode pin diode) that is in series with the receive path, and the part of CR5691 that is in shunt with the transmit path. The output of Q5680 is then coupled to a resistive pad R5697-R5699 which sets the power out of J5642 to approximately +12 dBm.

In the transmit mode, K9.4-V applies 9.4 V to the anode of CR5640, thus turning off Q5640. K9.4-V is also applied to resistors R5688 and R5694 which turn on the parts of CR5690 and CR5691 that are in series with the transmit path. The output of Q5680 is then coupled to a resistive pad (R5689-R5691) which sets the power out of J5641 to approximately +16 dBm.

3.5.3 800 MHz Band

3.5.3.1 General

The VCO is located on an alumina substrate with a metal cover. The buffer-doubler-buffer section is located on the PC board and may be repaired using normal repair methods.

3.5.3.2 Super Filter 8.6 V

Super filter 8.6 V is applied to the VCO carrier board at J601-12. From there, SF8.6 passes to the drain of Q9641, to the emitters of Q9643 and Q9644, and to the collector of Q9642.

3.5.3.3 VCO

Q9641, the main and transmit/TalkAround transmission lines, and the varactors CR9641 through CR9644 form the major circuitry of the oscillator. CR9645, C9648, C9647, and R9641 make up an automatic gain control (AGC) circuit.

The positive steering line connects to the cathodes of the four varactors and the negative steering line connects to the anodes. The negative line should be -4.0 ± 0.3 V and the positive line can go as high as 9 V, allowing a difference of 15 to 16 V between the two. Normally, at room temperature, the positive steering line will be between 1.5 and 5.5 V and will fluctuate with temperature change in the radio. Modulation is connected to the negative steering line via R9651 and C9651.

When the radio is transmitting, the oscillator's frequency will be in the 403 to 412 MHz range. When receiving, the frequency will be between 370.675 and 379.675 MHz. If the radio is in the TalkAround mode, the frequency will be between 425.5 and 434.5 MHz. The transmit and TalkAround ranges are produced by coupling an additional length of transmission line to the main transmission line and is done by a high or low on the AUX 1* or AUX 2* input lines.

3.5.3.4 Receive Mode-AUX 1* and AUX 2* High

When AUX 1* is HIGH, 8.6 V is applied to the cathode of CR9646. Q9643 is turned off and Q9647 is turned on placing approximately -6.2 V at the anode of CR9646 reverse biasing it. Likewise with AUX 2* high the same occurs except CR9647 is reversed biased with Q9644 off and Q9646 on. This isolates the TRANSMIT/TALKAROUND transmission line from the MAIN transmission line.

3.5.3.5 Transmit Mode-AUX 1* High; AUX 2* Low

When AUX 1* is high, the same occurs as mentioned above, however, with AUX 2* low, CR9647 is forward-biased, connecting the TRANSMIT/TALKAROUND transmission line through C9658 and C9657 to the MAIN transmission line.

3.5.3.6 TalkAround Mode-AUX 1* Low; AUX 2* Low

With AUX 1* and AUX 2* low, CR9647 and CR9646 are forward-biased, connecting the TRANSMIT/TALKAROUND transmission line through C9656, C9655, C9657, and C9658 to the MAIN transmission line.

3.5.3.7 VCO Buffer

Q9642 amplifies and provides reverse isolation to the oscillator. The frequency is then applied to the buffer-doubler-buffer section of the VCO carrier board.

3.5.3.8 First Buffer Circuit

The VCO output is coupled to the first buffer section through C9677. Q9660 amplifies and provides additional isolation between the doubler and the VCO.

3.5.3.9 Doubler

The first buffer output is coupled to the doubler section through C9662 and a lowpass input match circuitry (C9675, L9675, C9676, and L9676), which serves two purposes: it matches the input of the doubler to 50 ohms, and improves isolation between the VCO and doubler. It also keeps the desired doubler output frequency from getting to the synthesizer. The synthesizer feedback frequency is via C9674 and R9669.

Q9675 doubles the frequency applied to its base. The components on the collector are built so that a 400 MHz signal is effectively shorted to ground, while the 800 MHz signal sees high impedance to ground. The doubler is coupled to the buffer through C9681, and into a 50-ohm matching network made up of C9683 and L9680.

Doubler-biasing differs between receive mode and transmit mode. For receive, R9677, R9678, and R9676 (in parallel to dissipate power) plus R9679 and R9680 bias the base of Q9675 to 0.7-V potential, if NO input RF power is applied to the base. For transmit mode, keyed 9.4 V is fed through CR9694 and another parallel resistor network R9674 and R9675. This raises the current to the collector of Q9675 via L9678, producing more power out.

3.5.3.10 Second Buffer

The second buffer circuit is Q9676 with a 460 MHz trap, made up of L9682 and C9686, on the collector. The signal is coupled by series LC network of L9683 and C9687. For the receive mode, Q9676's gain is approximately 1 to 4 dB; in transmit, its gain is approximately 7 dB.

In receive mode, K9.4-volts is off so that the base voltage of Q9692 is controlled by voltage divider, R9694 and R9695. With temperature changes, the emitter-base junction of Q9691 tracks that of Q9692's, stabilizing the collector current and collector voltage of Q9676. R9690, R9691, and R9692 set the current level to the collector of Q9676 in receive.

In transmit mode, K9.4-volts is applied to CR9693 and through R9697, R9699, and R9693, increasing the current flow to Q9676. K9.4-volts on the anode of CR9690 increases the voltage on the base of Q9692. This increases voltage at Q9692's emitter and Q9676's collector. In the transmit mode, the buffer draws approximately 60 mA.

3.5.3.11 K9.4 V Switch

In the receive mode, K9.4-volts is off. CR9691 is reverse-biased, CR9692 is forward-biased; therefore Q9693 conducts to produce 9.4 V on the collector. This forward-biases CR9678 and CR9677, allowing RF to pass through C9688. R9687, R9688, and R9689 drop the 12 dBm signal on the anode of CR9678 down to 0 to 5 dBm. This is the receiver injection signal which is applied to the first mixer in the front end of the radio.

In the transmit mode, K9.4-volts is on. Q9693 turns off, reverse biasing CR9678 and CR9677. However, CR9675 and CR9676 are forward-biased, allowing the RF signal to pass through C9689. The signal (approximately 20 dBm) at the junction of CR9675 and CR9677, is attenuated about 1 dB across the diodes. The transmit signal, at approximately 18 to 23 dBm, is applied to the power amplifier via C9689.

3.6 Receiver Front-End

This section of the theory of operation provides a detailed circuit description of receiver front-end (RXFE). When reading the Theory of Operation, refer to your appropriate schematic and component location diagrams located in [“Chapter 7. Schematics, Component Location Diagrams and Parts Lists”](#). This detailed Theory of Operation will help isolate the problem to a particular component. However, first use the *ASTRO Digital Spectra and Digital Spectra Plus Mobile Radios Basic Service Manual* to troubleshoot the problem to a particular board.

3.6.1 VHF Band

3.6.1.1 General

The Receiver Front-End (RXFE) performs the first conversion of the received signal. The inbound signal is mixed with the high side injection signal, to produce the 109.65 MHz first IF. The pre-amp/mixer configuration of the RXFE includes a preamplifier, a factory-tuned, 5-pole L.C. preselector unique for two ranges, a fixed injection filter, and a double balanced mixer.

3.6.1.2 Theory of Operation

The RF input from the PA first enters the high pass filter consisting of components L3200, L3201, L3202, C3200, C3201, C3209, and C3210. The high pass filter attenuates signals below the receiver passband for both RF frequency ranges.

A pair of Schottky diodes (CR3200) located before the high pass filter and after the 5-pole L.C. preselector, limit the signal amplitude going into the preamplifier. A second pair of Schottky diodes (CR3201) located after the 5-pole L.C. preselector, further provide signal protection to the mixer.

The RF board supplies DC voltage to the pre-amp. Transistors Q3200 and Q3201 stabilize the bias for pre-amp device Q3202 through temperature changes. R3206, R3200, R3210, R3208, and R3209 are adjusted to meet radio performance specifications for High or Low sensitivity.

The factory-tuned preselector filter accepts RF input frequencies ranging from 136-162 MHz (Range 1) or 146-174 MHz (Range 2). L3100, L3101, L3102, L3103, L3104 comprise the set of inductors which are tuned by the factory.

The double-balanced mixer has an injection level of +20 dBm, common for both ranges; at its output, a diplexer helps terminate the IF port at all frequencies of interest, and forms the bandpass filter.

From the pre-amp input to the IF output, there should be a conversion gain of -1.5 to +3.5 dB for high sensitivity, and +7.0 to +10 dB for low sensitivity specifications.

3.6.2 UHF Band

3.6.2.1 General

The receiver ceramic filter has a typical insertion loss of about 0.5 to 1.5 dB; it should not have a loss greater than 2.0 dB. If any soldering must be done on the filter, be very careful not to get any solder on the filter tuning pads.

The injection filter is a printed pattern on the substrate which is laser-tuned at the factory. The insertion loss of this filter is about 3 dB.

3.6.2.2 Theory of Operation

The factory-tuned ceramic preselector filter accommodates RF input frequencies ranging from 438 to 470 MHz (Range 2), 450 to 482 MHz (Range 3), or 482 to 512 MHz (Range 4). The injection filter is tuned to pass frequencies from 549 to 580 MHz for Range 2, 559 to 592 MHz for Range 3, or 592 to 622 MHz for Range 4. Each frequency is connected at a node just before C9138 via a transmission line which acts as a high impedance input to the other frequency.

The RF board supplies DC voltage to bias the mixer Q125. Transistor Q126 controls the voltage to the base of Q125. The voltage at the collector of Q125 should be approximately 10 V.

3.6.3 800 MHz Band

3.6.3.1 General

The receiver ceramic filter has a typical insertion loss of about 1.6 to 1.7 dB; it should not have a loss greater than 2.5 dB. If any soldering must be done on the filter, be very careful not to get any solder on the filter tuning pads.

The injection filter is a printed pattern on the substrate which is laser-tuned at the factory. The insertion loss of this filter is about 3 dB.

3.6.3.2 Theory of Operation

The factory-tuned ceramic prescaler filter accommodates RF input frequencies ranging from 851 to 870 MHz. The injection filter is tuned to pass frequencies from 741 to 760 MHz. Each frequency is connected at a node just before C8126 via a transmission line which acts as a high impedance input to the other frequency.

DC voltage, supplied from the RF board, biases the mixer Q8126. Transistors Q8127 and Q8128 control the voltage to the base of Q8126. Q8128 acts as a diode to maintain a voltage on the base of Q8127, which keeps the bias of Q8126 stable through temperature changes. The voltage for the collector of Q8126, which passes through R8128, L8131, and L8130 should be approximately 8 volts.

C8129, L8129, C8131, and L8130 form the output network for the mixer. C8131 is a large capacitor that appears as a short to all frequencies of interest. The remaining components form a bandpass filter centered at the IF frequency.

R8130, R8129, and R8131 form an attenuator on the output path to stabilize both the mixer output impedance and the source impedance for the IF amplifier.

From the input to the ceramic filter to the IF output, there should be an 8 dB power gain presented to the IF. If the beta of Q8126 falls below 60, the mixer (Q8126) is probably bad and must be replaced.

3.7 Power Amplifiers

This section of the theory of operation provides a detailed circuit description of the power amplifiers. When reading the Theory of Operation, refer to your appropriate schematic and component location diagrams located in "[Chapter 7. Schematics, Component Location Diagrams and Parts Lists](#)". This detailed Theory of Operation will help isolate the problem to a particular component. However, first use the *ASTRO Digital Spectra and Digital Spectra Plus Mobile Radios Basic Service Manual* to troubleshoot the problem to a particular board.

3.7.1 VHF Band Power Amplifiers

3.7.1.1 High-Power Amplifier

3.7.1.1.1 Transmitter

The high-power ASTRO Spectra amplifier is discussed in the following text. A block diagram of the circuit is shown on the foldout drawing.

Transmit Low Level Amplifier (LLA)

The LLA is the first stage of the PA and provides a gain that is a function of the control voltage. This control voltage comes from the Regulator Power Control IC (RPCIC) on the command board. The magnitude of the control voltage depends on PA output power, temperature, and final amplifier current drain. See Section [3.7.1.1.3, "Power Control Circuitry,"](#) on page 3-57 for a detailed explanation of the power control circuitry.

The LLA, Q3801, is unique in that its gain is controlled by varying the collector's current rather than its voltage. Q3801 and associated circuitry (Q3806 Q3802, R3804, and R3818) are best described as a voltage-controlled current source. This means that the collector current of Q3801 is controlled by the magnitude of the control voltage.

Second Amplifier Stage

The second stage of the PA, Q3804, amplifies the output of the LLA to a level sufficient to drive the third stage device, Q3805. Q3804 amplifies the LLA output from approximately 300 mW to 3.0 Watts.

Driver Stage (Q3805)

The third stage uses a 3.0-Watt input to 30-Watt output device. It is driven by the second stage through a matching circuit that consists of C3824, L3808, C3819, and C3820. L3812 and L3809 give the device a zero-Vdc base bias (required for Class-C operation). The network of L3811, L3810, R3819, and C3821 provide A+ to the collector.

Final Stage (Q3870 AND Q3871)

The final amplifier stage is the parallel combination of two 15-Watt input to 75-Watt output RF transistors. The matching network, from the collector of the driver device Q3805 to the bases of the final devices Q3870 and Q3871, utilizes transmission lines as part of a combination matching network and power splitter. The capacitors C3860, C3861, C3862, and C3863 are on the bottom side of the PC board underneath the base leads of Q3870 and Q3871.

The DC bias path for the base of Q3870 is via L3930 and L3931. Q3871 has a similar network. R4007, R4008, and R3859 improve division of driver power between the final devices Q3870 and Q3871.

A feedback network consisting of C3870, R3870, and L3870 suppresses parasitic oscillations in Q3870. Q3871 has a similar network.

The final stage output network serves the dual purpose of impedance matching and power combining of the two final devices. R3872 and R3873 help balance the load impedances presented to the collectors of the final devices. Filtered A+ is routed to the final amplifier devices via the current sense resistor R3841, the ferrite bead L3881, and the coil L3880. The final stage output network terminates at C3889, which is the input to the antenna switch. The circuit impedance is 50 ohms at this point.

3.7.1.1.2 Antenna Switch and Harmonic Filter

Antenna Switch

The antenna switch utilizes PIN diodes to form a low loss, high isolation RF relay. During transmit, PIN diodes CR3901, CR3902, and CR3903 are forward biased during transmit via the K9.4 supply and resistors R3900, R3901, R3902, and R3903. In this state, a low loss path exists from the final amplifier through PIN diode CR3901 and into the harmonic filter. PIN diodes CR3902, and CR3903 effectively shunt the path to the receiver front-end which protects the preamp or mixer device from excessive RF levels. A properly functioning switch will pass less than 10 mW of transmit power to the receiver front-end.

During receive, all three PIN diodes remain unbiased. This opens a low loss path from the harmonic filter to the receiver.

Harmonic Filter

The harmonic filter is a 7-pole low-pass filter consisting of screened plate capacitors and air-wound coils on a 0.035 inch thick ceramic substrate. The filter's primary function is to attenuate harmonic energy generated by the amplifier stages. The filter also adds some selectivity for the receiver.

3.7.1.1.3 Power Control Circuitry

Command Board Circuitry

Inside U500, the Regulator Power Control IC (see [Figure 3-20](#)) is an operational amplifier that has four inverting inputs, and one non-inverting input (at pin 44) which is the reference input for the entire power control loop of the power amplifier. The 3.2-V reference voltage at U500-44 is produced by dividing SW +5-V with the voltage-divider circuit, R514 and R515.

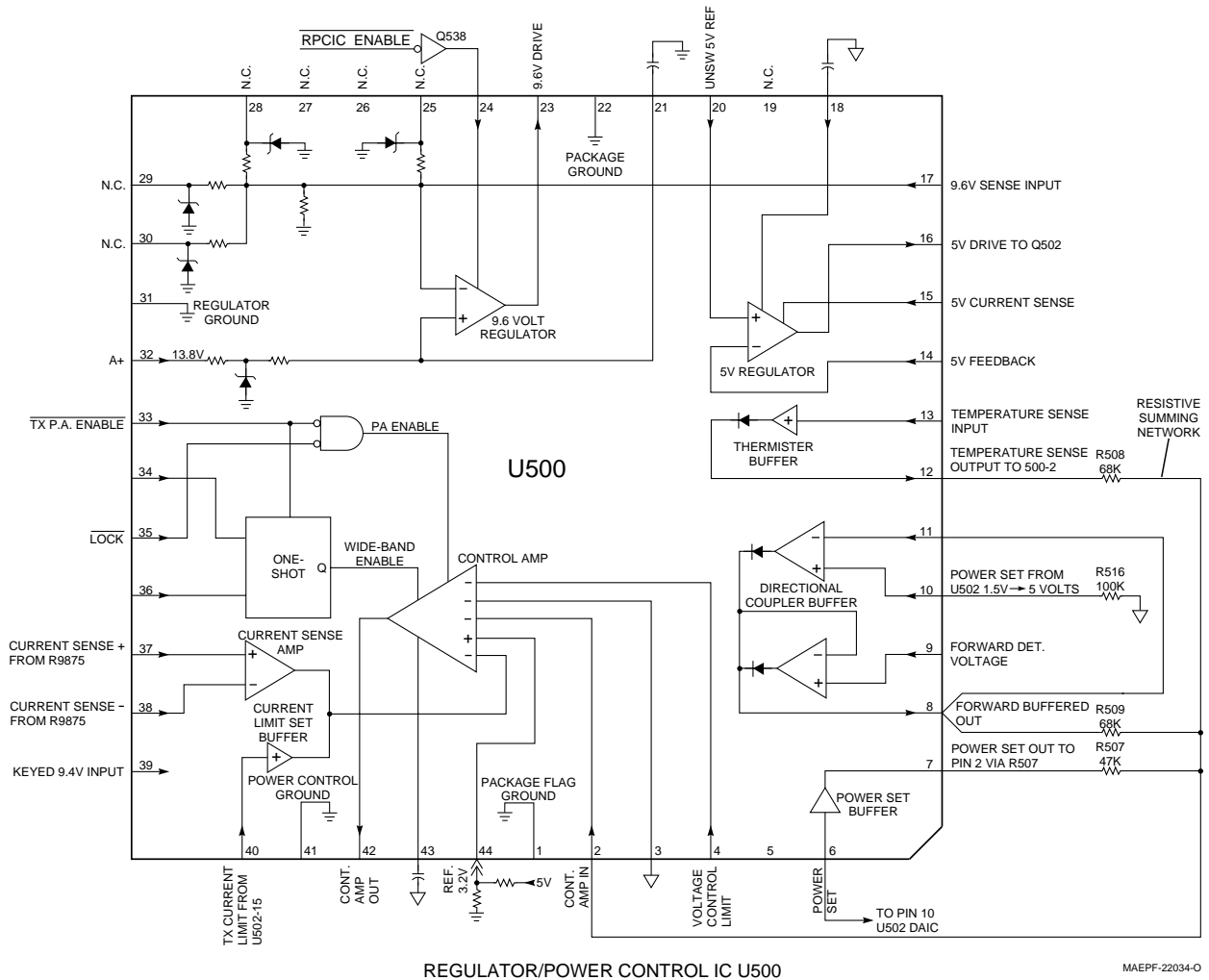

Figure 3-20. RPCIC Block Diagram

The power control loop is controlled by the microprocessor U204 on the VOCON board. Through the SLIC IC U206, the microprocessor enables the RPCIC by pulling TX PA ENABLE (U500 pin 33) low while the radio synthesizer is locked (U500 pin 35). U520 writes data to a digital-to-analog converter, U502, to change and control the power-set voltage from pin 10 of U502 to pin 6 of U500. The voltage on this line, 1.5 to 5 V, will be inversely proportional to the power out of the PA, with 5 V producing the lowest power output. This voltage may be set with RSS (Radio Service Software) or CPS (Customer Programming Software). On U500, the voltage at pin 6 is buffered internally and exits on pin 7. Through R507, it is connected to pin 2 of U500. Note that pin 2 of U500 is the summing point of three voltages: forward detect voltage, power set voltage, and temp-sense.

Control Voltage Limiter

R3807 and R3808 form a voltage divider that connects to control voltage drive. The output of this voltage divider is connected to the control-voltage-limit input (pin 4) of the RPCIC. If the voltage at this input reaches 3.2 V, then the control voltage will be clamped to a maximum value. For the high-power VHF PA, this maximum value is 9 V. This voltage control limit is set by the values of R3807 and R3808.

Current Limiter

U204, the processor on the VOCON board, sends data to U502, the digital-to-analog converter, to properly set the voltage on U502, pin 15, which is the TX CURRENT LIMIT control line to the RPCIC (U500, pin 40). Sixteen different voltages, ranging from 1.5 to 4.5 V, can be programmed from U502.

The collector current of the 110-Watt amplifier is monitored by sensing the voltage across R3849. CURRENT SENSE + connects to one end of R3849; CURRENT SENSE - connects to the other end. These lines connect to the command board on U500 pins 37 and 38, respectively. If the TX CURRENT LIMIT is set for 1.5 V, then the voltage difference between U500 pins 37 and 38 must be 0.1 V before the current through R3849 is reduced. If U500 pin 40 is programmed for 4.5 V, then the difference of potential between pins 37 and 38 must exceed 0.3 V before current limiting begins. The voltage across R3849, where current sense occurs, can be determined by multiplying the voltage on U500 pin 40, by 0.067. When current is being limited, the output of the op-amp (U500, pin 42) begins shutting down the conduction of Q503 and Q504, reducing PA control voltage, and reducing drive to the final amplifier to, effectively, control the final amplifier's maximum current.

Forward Power Limiter

After the harmonic filter a parallel pair of microstrip lines form a forward power sensing directional coupler and detector. The output of this directional coupler/detector is a DC voltage that is proportional to the forward RF power from the final amplifier. During normal transmission, the DC voltage from the forward detect line to the RPCIC ranges from 2 to 5.0 V. This voltage connects to U500 pin 9, the directional coupler buffer input.

The directional coupler's buffered output, U500 pin 8, is summed to pin 2 with the digital/analog buffer's output through R509 and R507, respectively. In typical operation, the closed loop operation of the circuit attempts to keep the voltage at U500 pin 2 a constant value of 3.2 V. The control amp will maintain this condition by increasing or decreasing the control amp output voltage. This control amp output voltage is routed to the LLA via transistors Q503 and Q504. The output of Q504 is designated "control voltage drive" and is routed to J1 pin 2 of the PA board.

Since control voltage drive controls the gain of the LLA, it determines the drive level to the following stages and thus the output power of the final amplifier. The output power of the final stage is detected by the directional coupler and is routed back to U500 pin 2 via the buffer and R507. Thus the loop is complete and forward power is maintained a constant value. The voltage at pin 2 will drop below 3.2 V during low line voltage conditions where the PA cannot produce rated power. Current limit and voltage control limit circuits will also affect the voltage at pin 2 as described in the following.

Temperature Sensing

The temperature-sensing circuit of the PA works with the RPCIC to protect the PA devices from excessively high temperatures. On the PA board, this circuit (formed by resistors R3916, R3841, and thermistor RT3842), provides a temperature dependent voltage to the RPCIC via J1 pin 6. As the PA temperature increases, the resistance of RT3842 decreases, causing the voltage at pin 6 to increase. This voltage is routed to the RPCIC, U500 pin 13, which is the input to the thermistor buffer. The buffer's output on pin 12 is connected to pin 2 via resistor R508. Note that pin 2 is the control amp input and is a summing point for temperature, forward-power detect, and power set signals. If the PA temperature becomes high enough so that the voltage at pin 7 exceeds 3.2 V, the thermistor buffer starts supplying current to the node at pin 2. Due to the fixed output current of the power-set buffer, the control loop can maintain 3.2 V at pin 2 only by reducing the forward-power detect voltage and, therefore, reducing the PA output power. Since power output is reduced, the generated heat is reduced to a safe level. If temperature decreases, the power output of the PA gradually increases to its nominal value.

NOTE: Under severe environmental conditions, more than one circuit may be attempting to reduce power output at the same time (i.e., during high VSWR conditions, the current limiter may initially reduce power, but eventual heat buildup will cause further power reduction by the thermal cut-back circuit).

The temperature sense circuitry can easily be tested by placing an ordinary leaded 4.7k ohm resistor across RT3842. PA output power should drop significantly if this circuit is working properly.

3.7.1.2 25/10-Watt Power Amplifier

Transmitter

The 25/10-Watt Spectra power amplifier is discussed in the following text.

Transmit Low Level Amplifier (LLA)

NOTE: The minimum input drive level to the PA into J3850 is 10 mW. Refer to the synthesizer section if input drive is less than 10 mW.

The Low Level Amplifier, the first stage of the PA, provides a gain that is a function of a control voltage. This control voltage comes from the Regulator Power Control IC (RPCIC) on the command board. The magnitude of the control voltage depends on PA output power, temperature, and final amplifier current drain.

The LLA, Q3801, is unique in that its gain is controlled by varying the collector's current rather than its voltage. Q3801 and associated circuitry (Q3806, Q3802, R3804, and R3818) are best described as a voltage-controlled current source. This means that the collector current of Q3801 is controlled by the magnitude of the control voltage. Proper operation of the LLA can be checked by monitoring the voltage across the resistor R3804. The voltage should measure in the range of 0.1 V to 1.0 V, depending on the value of control voltage. A 0.1-V reading corresponds to a low control voltage (1 to 5 V) and a 1.0 V reading corresponds to a high control voltage (up to control voltage limit).

Driver Stage

The second stage of the PA, Q3804, is the driver. The purpose of this stage is to amplify the output of the LLA to a level sufficient to drive the final device, Q3850. Input power to this stage is approximately 100 mw; output power from this stage is 3.5 Watts.

Final Stage

The final device is a 3- to 33-Watt device and is driven by the driver through a low-pass matching circuit that consists of C3815, C3816, C3817, L3811, C3819, C3821, C3822, C3823 and associated transmission lines. Base network, L3852, L3851, and R3815, R3819 provide the zero-DC bias required by the final device's Class-C operation. L3852 and L3851 provide the DC path from base to ground. R3815 and R3819 help lower the network's Q at low frequencies. The collector DC network consists of L3875, L3876, R3876, R3877, C3880, C3885, C3881, C3882, and CR3875. This network provides the A+ voltage to the final while blocking RF from getting up the DC line. L3875 and L3876 provide the DC path and block RF. R3876 and R3877 resistively load down the final's collector at low frequencies and prevent unwanted oscillations. C3881, C3882, C3880, and C3885 are all bypass capacitors ranging from very low frequencies up to VHF frequencies. R3875 is the current-sense resistor. CR3875 protects against reverse polarity. Finally, the RF signal goes through a low-pass matching network (C3875, C3877, C3878, C3879, L3877, and associated transmission lines) to the rest of the output network (Directional Coupler, Antenna Switch, and Harmonic Filter).

3.7.1.2.1 Antenna Switch and Harmonic Filter

Antenna Switch

The antenna switch's impedance inverter circuit, made up of C3920 and L3920, takes the place of a quarter-wave microstrip line. During transmission, Keyed 9.4 V forward-biases CR3921, producing low impedance on CR3921's anode and high impedance on the C3920/L3920 node. Effectively, this isolates the transmitted power from the receiver. C3910 couples the power to the harmonic filter and on to the antenna.

Total TX to RX isolation exceeds 50 dB from 136-174 MHz. The impedance inverter contributes approximately 30 db to transmit isolation. A second shunt switch, made up of CR3922, L3921, C3922, and C3921, provide additional isolation. C3926 and C3923 block DC.

During RX, CR3920 has an OFF capacitance of approximately 1 pF. CR3921 and CR3922, incorporated in the RX match, have similar OFF capacitance.

Harmonic Filter

The 25/10-Watt harmonic filter is a 7-pole, low-pass filter, consisting of high-Q chip capacitors (C3911, C3913, C3912, and C3914) and discrete inductors (L3911, L3912, and L3913). The filter's primary function is to attenuate harmonic spurs generated by the transmitter. It also adds low-pass selectivity for the receiver. L3914 protects the PA from static discharge.

3.7.1.2.2 Power Control Circuitry

Command Board Circuitry

Inside U500, the Regulator Power Control IC (see [Figure 3-21 on page 3-61](#)), is an operational amplifier that has four inverting inputs, and one non-inverting input (at pin 44) which is the reference input for the entire power control loop of the power amplifier. The 3.2-V reference voltage at U500-44 is produced by dividing SW +5-V with the voltage-divider circuit, R514 and R515.

The power control loop is controlled by the microprocessor U204 on the VOCON board. Through the SLIC IC U206, the microprocessor enables the RPCIC by pulling TX PA ENABLE (U500 pin 33) low while the radio synthesizer is locked (U500 pin 35). U520 writes data to a digital-to-analog converter, U502, to change and control the power-set voltage from pin 10 of U502 to pin 6 of U500. The voltage on this line, 1.5 to 5 V, will be inversely proportional to the power out of the PA, with 5 V producing the lowest power output. This voltage may be set with RSS (Radio Service Software) or CPS (Customer Programming Software).

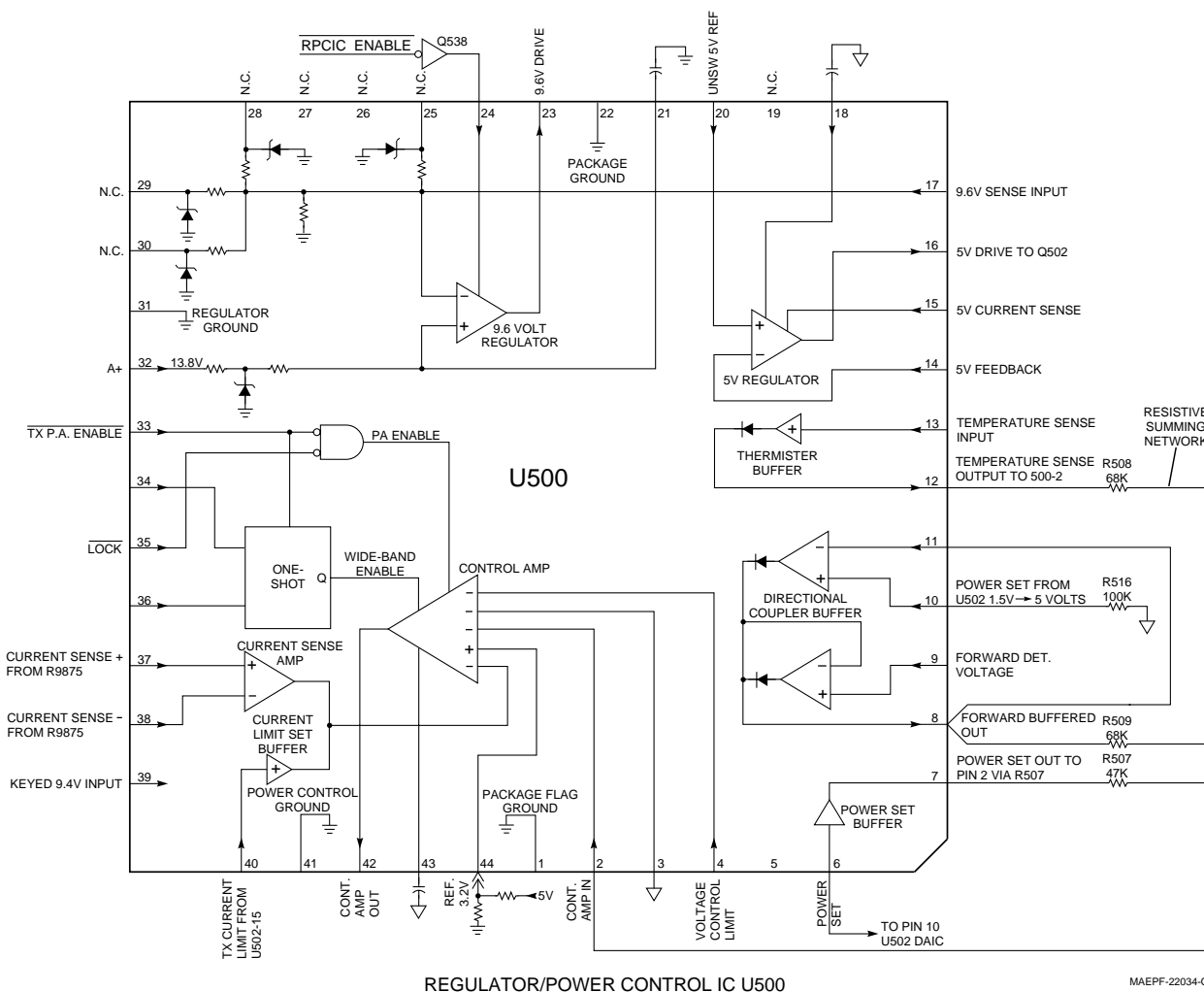

Figure 3-21. Regulator/Power Control IC Block Diagram

Control Voltage Limiter

R3813 and R3814 form a voltage divider that connects to control voltage drive. The output of this voltage divider is connected to the control-voltage-limit input (pin 4) of the RPCIC. If the voltage at this input reaches 3.2 V, then the control voltage will be clamped to a maximum value. For the 25/10-Watt VHF PA, this maximum value is 9.2 V. This voltage-control limit is set by the values of R3813 and R3814.

Current Limiter

U204, the processor on the VOCON board, sends data to U502, the digital-to-analog converter, to properly set the voltage on U502, pin 15, which is the TX CURRENT LIMIT control line to the RPCIC (U500, pin 40). Sixteen different voltages, ranging from 1.5 to 4.5 V, can be programmed from U502.

The collector currents of the 25/10-Watt amplifier is monitored by sensing the voltage across R3875. CURRENT SENSE + connects to one end of R3875; CURRENT SENSE - connects to the other end. These lines connect to the command board on U500, Pins 37 and 38, respectively. If the TX CURRENT LIMIT is set for 1.5 V, then the voltage difference between U500, Pins 37 and 38 must be 0.1 V before the current through R3875 is reduced. If U500, pin 40 is programmed for 4.5 V, then the difference of potential between Pins 37 and 38 must exceed 0.3 V before current limiting begins. The voltage across R3875, where current sense occurs, can be determined by multiplying the voltage on U500, pin 40, by 0.067. When current is being limited, the output of the op-amp (U500, pin 42) begins shutting down the conduction of Q503 and Q504, reducing PA control voltage, and reducing drive to the final amplifier to control the final amplifier's maximum current.

Forward Power Limiter

After the final amplifier, a parallel pair of non-symmetrical microstrip lines form a forward power-sensing directional coupler. Because of increased coupling with frequency, C3902 is used to compensate and filter out harmonics. R3905, R3906, C3903, and L3903 provide DC bias to CR3900, which rectifies the signal. During normal transmission, the DC voltage from the forward-detect line to the RPCIC ranges from 1.5 to 5.0 V. This voltage connects to U500, pin 9, the directional coupler buffer input.

The directional coupler's output, U500 pin 8, is summed to pin 2 with the digital/analog buffer's output through R509 and R507, respectively.

Closed loop operation reduces the control amp's output (pin 42), reduces the power amplifier's gain, and reduces power output to maintain the coupler buffer output (U500, pin 2) at 3.2 V regardless of the D/A voltage level. If the D/A voltage is high (4.5 V), little detected voltage is needed to keep pin 2 at 3.2 V, and the power, consequently, is low. If the D/A voltage is low (1.5 V), a large forward detected voltage is needed to keep pin 2 at 3.2 V and power, consequently, is at maximum value. The voltage at pin 2 drops below 3.2 V under proper operation during low line voltage conditions where the PA cannot produce rated power, or if, under any conditions, the control voltage, or the final device current exceeds safe levels.

Temperature Sensing

The temperature-sensing circuit of the PA works with the RPCIC to protect the PA devices from excessively high temperatures. On the PA board, this circuit, formed by resistors R3878, R3879, and thermistor RT3876, provides a temperature-dependent voltage to the RPCIC via P0853, pin 7. As the PA temperature increases, the resistance of RT3876 decreases, causing the voltage at pin 7 to increase. This voltage is routed to the RPCIC, U500, pin 13, which is the input to the thermistor buffer. The buffer's output on pin 12 is connected to pin 2 via resistor R508. Note that pin 2 is the control amp input and is a summing point for temperature, forward-power detect, and power set signals. If the PA temperature becomes high enough so that the voltage at pin 7 exceeds 3.2 V, the thermistor buffer starts supplying current to the node at pin 2. Due to the fixed output current of the power-set buffer, the control loop can maintain 3.2 V at pin 2 only by reducing the forward-power detect voltage and, therefore, reducing the PA output power. Since power output is reduced, the generated heat is reduced to a safe level. If temperature decreases, the power output of the PA gradually increases to its nominal value. Temperature cutback should occur at about 140°F (60°C).

The temperature sense circuitry can easily be tested by placing an ordinary leaded 4.7k ohm resistor across RT3876. PA output power should drop significantly if this circuit is working properly.

NOTE: Under severe environmental conditions, more than one circuit may be attempting to reduce power output at the same time (i.e., during high VSWR conditions, the current limiter may initially reduce power, but eventual heat buildup will cause further power reduction by the thermal cut-back circuit).

3.7.1.3 50-Watt Power Amplifiers

3.7.1.3.1 Transmitter

The 50-Watt ASTRO Spectra power amplifiers (PA's) are discussed in the following text. A block diagram of the circuit is shown in [Figure 3-22](#).

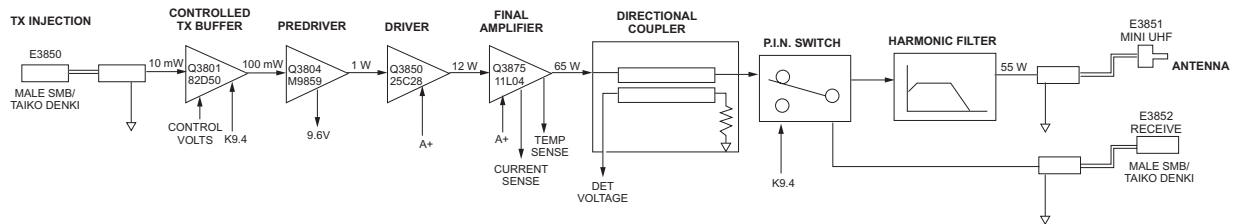

Figure 3-22. 50-Watt Power Amplifier Block Diagram

Transmit Low Level Amplifier (LLA)

NOTE: The minimum input drive level to the PA into J3850 is 10 mW. Refer to the synthesizer section if input drive is less than 10 mW.

The LLA, the first stage of the of the PA, provides a gain that is a function of a control voltage. This control voltage comes from the Regulator Power Control IC (RPCIC) on the command board. The magnitude of the control voltage depends on PA output power, temperature, and final amplifier current drain.

The LLA, Q3801, is unique in that its gain is controlled by varying the collector's current rather than its voltage. Transistor Q3801 and associated circuitry (Q3806, Q3802, R3804, and R3818) are best described as a voltage-controlled current source. This means that the collector current of Q3801 is controlled by the magnitude of the control voltage. Proper operation of the LLA can be checked by monitoring the voltage across the resistor R3804. The voltage should measure in the range of 0.1 V to 1.0 V, depending on the value of control voltage. A 0.1-V reading corresponds to a low control voltage (1 to 5 V) and a 1.0-V reading corresponds to a high control voltage (up to control voltage limit).

Predriver Stage

The second stage of the PA, Q3804, is the predriver. The purpose of this stage is to amplify the output of the LLA to a level sufficient to drive the driver device, Q3850. Input power to this stage is approximately 100 mW; output power from this stage is 1.0 Watt.

Driver Stage

The driver is a 1.2- to 15-Watt device. It is driven by the predriver device through a matching circuit that consists of C3815, C3816, C3817, C3818, and L3811. A ferrite bead L3810, and a parallel resistor, R3815, give the driver a zero-DC bias required for the driver's Class C operation, and provides a low Q network to prevent unwanted oscillations. The network of L3851, L3854, C3858, C3856, C3855, and R3850 provide A+ to the collector. L3851 and L3854 provide the DC path and block RF from coming up the DC line. R3850 resistively loads down the collector at low frequencies, preventing unwanted oscillations. C3856, C3855, C3858, and C3855 are bypass capacitors.

Final Stage

The final device is a 12- to 75-Watt device and is driven by the driver through a low pass matching circuit that consists of C3850 through C3854 and associated transmission lines. Base network, L3852, L3853, and R3851, provide the zero-DC bias required by the final device's Class C operation. L3852 and L3851 provide the DC path from base to ground. R3851 helps lower the network's Q at low frequencies. The collector DC network consists of L3875, L3876, R3876, C3880, C3885, C3881, C3882, and CR3875. This network provides the A+ voltage to the final stage while blocking RF from getting up the DC line. L3875 and L3876 provide the DC path and block RF. R3850 resistively loads down the final stage's collector at low frequencies and prevents unwanted oscillations. C3881, C3882, C3880, and C3885 are all bypass capacitors ranging from very low frequencies up to VHF frequencies. R3875 is the current sense resistor. CR3875 protects against reverse polarity. Finally, the RF signal goes through a low pass matching network (C3875, C3876, C3877, C3878, C3879, L3877, and associated transmission lines) to the rest of the output network (directional coupler, antennal switch, and harmonic filter).

3.7.1.3.2 Antenna Switch and Harmonic Filter

Antenna Switch

The antenna switches impedance inverter circuit, made up of C3920 and L3920, takes the place of a quarter-wave microstrip line. During transmission, keyed 9.4 V forward biases CR3921, producing a low impedance on CR3921's anode and a high impedance on the C3920/L3920 node. Effectively, this isolates the transmitted power from the receiver. C3910 couples the power to the harmonic filter and on to the antenna.

Total TX to RX isolation exceeds 55dB from 136-174MHz. The impedance inverter contributes approximately 35dB to transmit isolation. A second shunt switch made up of CR3922, L3921 and C3921, provide additional isolation. Capacitors C3922 and C3923 block DC.

During RX, CR3920 has an OFF capacitance of approximately 1 pF. CR3921 and CR3922 incorporated in the RX match have a similar OFF capacitance.

Harmonic Filter

The 50-Watt harmonic filter is a 7-pole, low-pass filter, consisting of high Q chip capacitors (C3911 thru C3914) and discrete inductors (L3911 thru L3913). The filter's primary function is to attenuate harmonic spurs generated by the transmitter, It also adds low-pass selectivity for the receiver. L3914 protects the PA from static discharge.

3.7.1.3.3 Power Control Circuitry

Command Board Circuitry

Inside U500, the Regulator Power Control IC (Figure 3-23), is an operational amplifier that has four inverting inputs, and non-inverting input at pin 44 which is the reference input for the entire power control loop of the power amplifier. The 3.2-V reference voltage at U500-44 is produced by dividing SW +5-V with the voltage-divider circuit, R514 and R515.

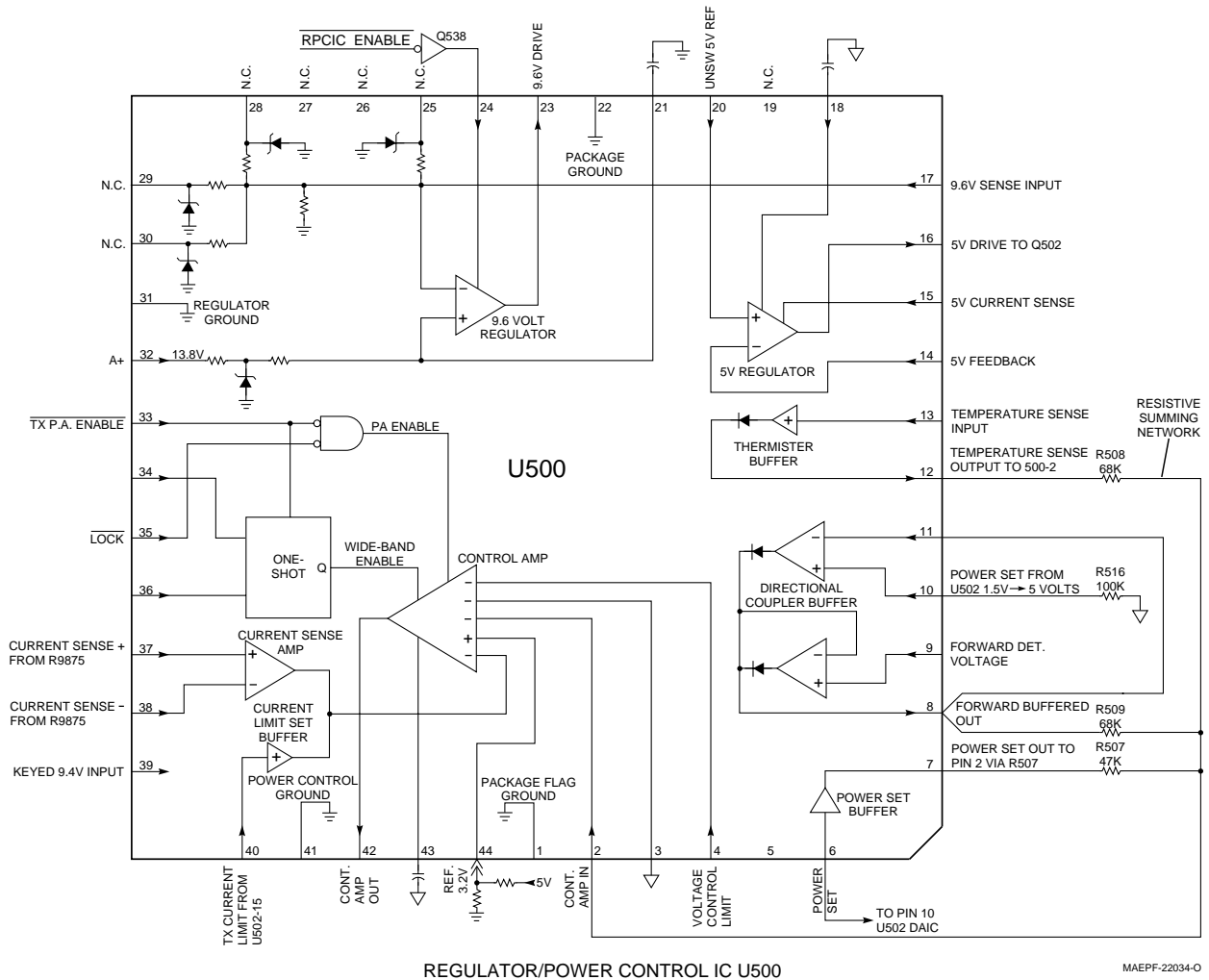

Figure 3-23. Regulator/Power Control IC Block Diagram

The power control loop is controlled by the microprocessor U204 on the VOCON board. Through the SLIC IC U206, the microprocessor enables the RPCIC by pulling TX PA ENABLE (U500 pin 33) low while the radio synthesizer is locked (U500 pin 35). U520 writes data to a digital-to-analog converter, U502, to change and control the power-set voltage from pin 10 of U502 to pin 6 of U500. The voltage on this line, 1.5 to 5 V, will be inversely proportional to the power out of the PA, with 5 V producing the lowest power output. This voltage may be set with RSS (Radio Service Software) or CPS (Customer Programming Software).

Control Voltage Limiter

R3807 and R3808 form a voltage divider that connects to control voltage drive. The output of this voltage divider is connected to the control-voltage-limit input, pin 4 of the RPCIC. If the voltage at this input reaches 3.2 V, then the control voltage will be clamped to a maximum value. For the 50-Watt VHF PA, this maximum value is 8 V. This voltage control limit is set by the values of R3807 and R3808.

Current Limiter

U204, the processor on the VOCON board, sends data to U502, the digital-to-analog converter, to properly set the voltage on U502, pin 15, which is the TX CURRENT LIMIT control line to the RPCIC, U500, pin 40. Sixteen different voltages, ranging from 1.5 to 4.5 V, can be programmed from U502.

The collector current of the amplifier is monitored by sensing the voltage across R3875; CURRENT SENSE + connects to one end of R3875; CURRENT SENSE - connects to the other end. These lines connect to the command board on U500, pins 37 and 38 respectively. If the TX CURRENT LIMIT is set for 1.5 V, then the voltage difference between U500, pins 37 and 38 must be 0.1 V before the current through R3875 is reduced. If U500, pin 40 is programmed for 4.5 V, then the difference of potential between pins 37 and 38 must exceed 0.3 V before current limiting begins. The voltage across R3875, where current sense occurs, can be determined by multiplying the voltage on U500, pin 40, by 0.067 V. When current is being limited, the output of the operational amplifier, U500, pin 42 begins shutting down the conduction of Q503 and Q504, reducing PA control voltage, and reducing drive to the final amplifier to effectively control the final amplifier's maximum current.

Forward Power Limiter

After the final amplifier, a parallel pair of non-symmetrical microstrip lines form a forward power-sensing directional coupler. Because of increased coupling with frequency, C3902 is used to compensate and filter out harmonics. R3905, R3906, C3902, and L3903 provide DC bias to CR3900, which rectifies the signal. During normal transmission, the DC voltage from the forward-detect line to the RPCIC ranges from 2 to 4.5 V. This voltage connects to U500, pin 9, the directional coupler buffer input.

The directional coupler's output, U500 pin 8, is summed to pin 2 with the digital/analog buffer's output through R509 and R507 respectively.

Closed loop operation reduces the control amplifier's output pin 42, reduces the power module's gain, and reduces power output to maintain the coupler buffer output U500, pin 2 at 3.2 V regardless of the D/A voltage level. If the D/A voltage is high (4.5 V), little detected voltage is needed to keep pin 2 at 3.2 V, and the power, consequently, is low. If the D/A voltage is low (1.5 V), a large forward detected voltage is needed to keep pin 2 at 3.2 V and power, consequently, is at maximum value. The voltage at pin 2 drops below 3.2 V under proper operation during low line voltage conditions where the PA cannot produce rated power, or if, under any conditions, the control voltage, or the final device current exceeds safe levels.

Temperature Sensing

The temperature-sensing circuit of the PA works with the RPCIC to protect the PA devices from exclusively high temperatures. On the PA board, this circuit, formed by resistors R3878 thru R3880 and thermistor RT3877, provides a temperature-dependent voltage to the RPCIC via P0853, pin 7. As the PA temperature increases, the resistance of RT3875 decreases, causing the voltage at pin 7 to increase. This voltage is routed to the RPCIC, U500, pin 13, which is the input to the thermistor buffer. The buffer's output on pin 12 is connected to pin 2 via resistor R508. Note that pin 2 is the control amplifier input and is a summing point for temperature, forward-power detect, and power set signals. If the PA temperature becomes high enough so that the voltage at pin 7 exceeds 3.2 V, the thermistor buffer starts supplying current to the node at pin 2. Due to the fixed output current of the power-set buffer, the control loop can maintain 3.2 V at pin 2 only by reducing the forward-power detect voltage and therefore, reducing the PA output power. Since power output is reduced, the generated heat is reduced to a safe level. If temperature decreases, the power output of the PA gradually increases to its nominal value. Temperature cutback should occur at about 140 degrees F (60 degrees C).

The temperature sense circuitry can easily be tested by placing an ordinary leaded 4.7k ohm across RT3875, PA output power should drop significantly if this circuit is working properly.

NOTE: Under severe environmental conditions, more than one circuit may be attempting to reduce power output at the same time (i.e. during high VSWR conditions). The current limiter may initially reduce power, but eventual heat buildup will cause further power reduction by the thermal cut-back circuit.

3.7.2 UHF Band Power Amplifiers

3.7.2.1 High-Power Amplifier

3.7.2.1.1 Transmitter

The high-power Spectra amplifier is discussed in the following text. A block diagram of the circuit is shown in [Figure 3-24](#).

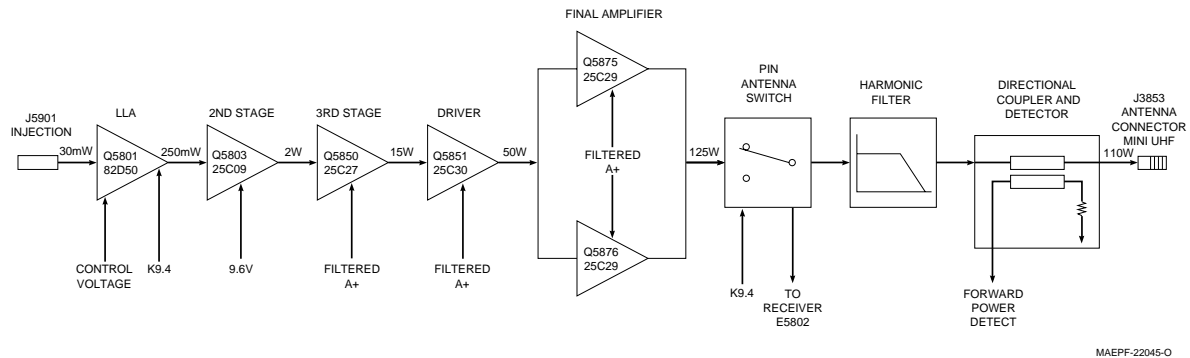

Figure 3-24. UHF High-Power, Power Amplifier Block Diagram

Transmit Low Level Amplifier (LLA)

The LLA is the first stage of the PA and provides a gain that is a function of a control voltage. This control voltage comes from the Regulator Power Control IC (RPCIC) on the command board. The magnitude of the control voltage depends on PA output power, temperature, and final amplifier current drain.

The LLA, Q5801, is unique in that its gain is controlled by varying the collectors current rather than its voltage. Q5801 and associated circuitry (Q5806, Q5800, R5805, and R5818) are best described as a voltage-controlled current source. This means that the collector current of Q5801 is controlled by the magnitude of the control voltage.

Second Amplifier Stage

The second stage of the PA, Q5803, amplifies the output of the LLA to a level sufficient to drive the third stage device, Q5850. Q5803 amplifies the LLA output from approximately 250 mW to 2.5 Watts.

Third Amplifier Stage

The third stage uses a 2.5-Watt input to 16-Watt output device. It is driven by the second stage through a matching circuit that consists of C5851, C5852, C5850, C5858, and L5850. L5851 and L5852 give the device a zero-Vdc base bias (required for Class-C operation). The network of L5853, L5854, C5856, C5857, and R5850 provide A+ to the collector.

Driver Stage

The driver stage uses a 15-Watt input to 50-Watt output device. It is driven by the third stage through the matching network consisting of C5853, C5854, C5855, C5861, C5862, and associated transmission lines. The DC bias path for the base is provided by L5855 and L5857. C5859, R5851, and C5860 are for the purpose of suppressing parasitic oscillations. Note that the capacitors C5861, C5862, C5863, and C5864 are placed on the bottom side of the PC board.

Final Stage

The final amplifier stage is the parallel combination of two 25-Watt input to 75-Watt output RF transistors. The matching network from the collector of the driver device Q5851 to the bases of the final devices Q5875 and Q5876 utilizes transmission lines as part of a combination matching network and power splitter. The capacitors C5885, C5886, C5887, and C5888 are on the bottom side of the PC board underneath the base leads of Q5875 and Q5876.

The DC bias path for the base of Q5875 is via L5877 and L5879. Q5876 has a similar network. R5878 improves division of driver power between the final devices Q5875 and Q5876.

A feedback network consisting of C5890, R5879, and L5881 suppresses parasitic oscillations in Q5875. Q5876 has a similar network.

The final stage output network serves the dual purpose of impedance matching and power combining of the two final devices. C5891, C5892, C5893, and C5894 are on the bottom side of the PC board underneath the collectors of the final devices. These capacitors are especially critical in terms of their exact physical placement.

R5881 and R5882 help balance the load impedances presented to the collectors of the final devices. Filtered A+ is routed to the final amplifier devices via the current sense resistor R5875, the ferrite bead L5884, and the coil L5882. The final stage output network terminates at C5900 which is the input to the antenna switch. The circuit impedance is 50 ohms at this point.

3.7.2.1.2 Antenna Switch and Harmonic Filter

Antenna Switch

The antenna switch utilizes PIN diodes to form a low loss, high isolation RF relay. During transmit, PIN diodes CR5900, CR5902, CR5904, and CR5905, are forward biased during transmit via the K9.4 supply and resistors R5901, R5900, R5908, and R5909. In this state, a low loss path exists from the final amplifier through PIN diode CR5900 and into the harmonic filter. PIN diodes CR5902, CR5904, and CR5905 effectively shunt the path to the receiver front-end, which protects the preamp or mixer device from excessive RF levels. A properly functioning switch will pass less than 10 mW of transmit power to the receiver front-end.

During receive, all four PIN diodes remain unbiased. This opens a low loss path from the harmonic filter to the receiver

Harmonic Filter

The harmonic filter is a 9-pole low-pass filter consisting of screened plate capacitors and air-wound coils on a 0.035 inch thick ceramic substrate. The filter's primary function is to attenuate harmonic energy generated by the amplifier stages. The filter also adds some selectivity for the receiver.

3.7.2.1.3 Power Control Circuitry

Command Board Circuitry

Inside U500, the Regulator Power Control IC ([Figure 3-25 on page 3-70](#)) is an operational amplifier that has four inverting inputs, and one non-inverting input (at pin 44) which is the reference input for the entire power control loop of the power amplifier. The 3.2-V reference voltage at U500-44 is produced by dividing SW +5-V with the voltage-divider circuit, R514 and R515.

The power control loop is controlled by the microprocessor U204 on the VOCON board. Through the SLIC IC U206, the microprocessor enables the RPCIC by pulling TX PA ENABLE (U500 pin 33) low while the radio synthesizer is locked (U500 pin 35). U520 writes data to a digital-to-analog converter, U502, to change and control the power-set voltage from pin 10 of U502 to pin 6 of U500. The voltage on this line, 1.5 to 5 V, will be inversely proportional to the power out of the PA, with 5 V producing the lowest power output. This voltage may be set with RSS (Radio Service Software) or CPS (Customer Programming Software).

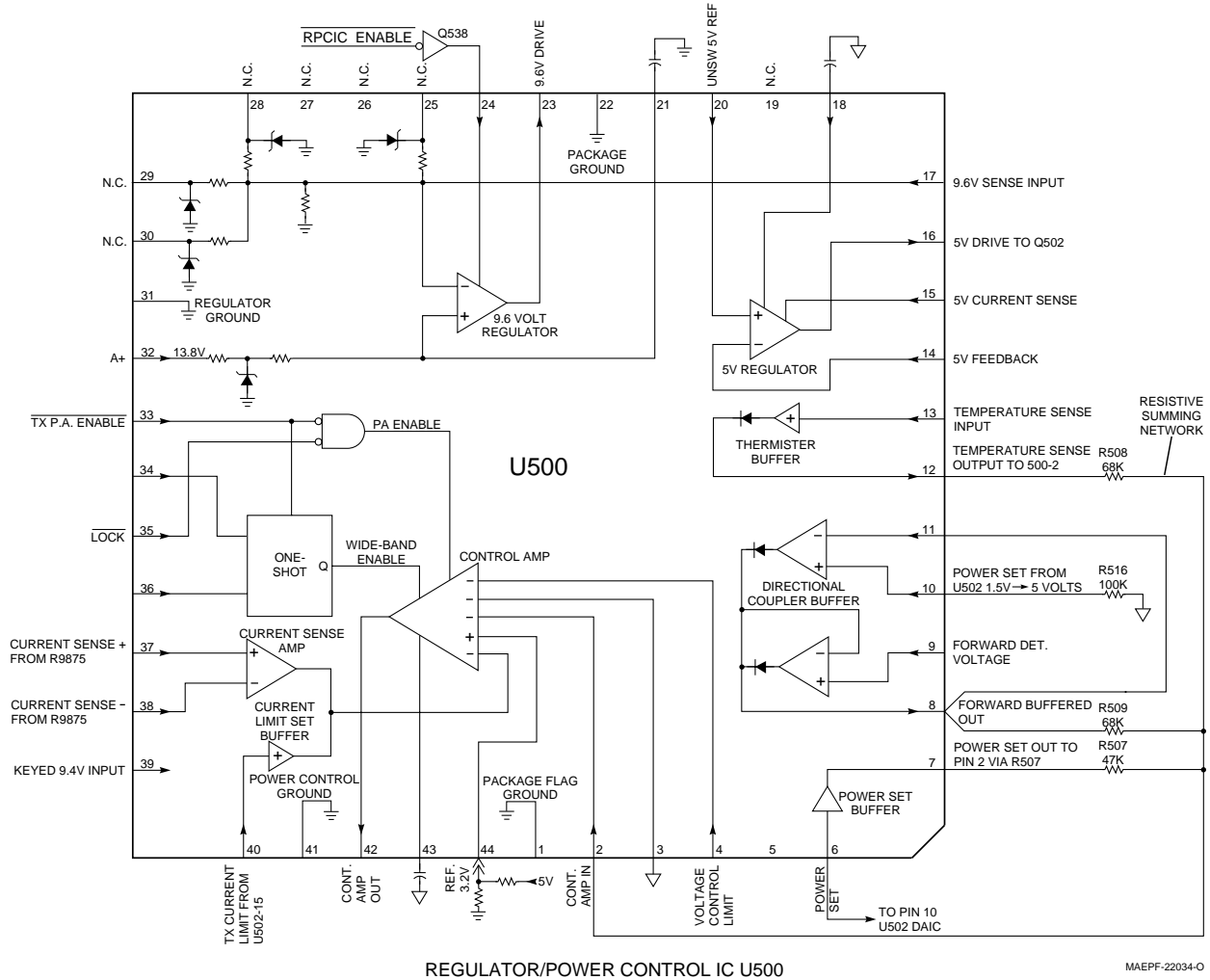

Figure 3-25. RPCIC Block Diagram

Control Voltage Limiter

R5807 and R5808 form a voltage divider that connects to control voltage drive. The output of this voltage divider is connected to the control-voltage-limit input (pin 4) of the RPCIC. If the voltage at this input reaches 3.2 V, then the control voltage will be clamped to a maximum value. For the high-power UHF PA, this maximum value is 10 V. This voltage control limit is set by the values of R5807 and R5808.

Current Limiter

U204, the processor on the VOCON board, sends data to U502, the digital-to-analog converter, to properly set the voltage on U502, pin 15, which is the TX CURRENT LIMIT control line to the RPCIC (U500, pin 40). Sixteen different voltages, ranging from 1.5 to 4.5 V, can be programmed from U502.

The collector current of the high-power amplifier is monitored by sensing the voltage across R5875. CURRENT SENSE + connects to one end of R5875; CURRENT SENSE - connects to the other end. These lines connect to the command board on U500 pins 37 and 38, respectively. If the TX CURRENT LIMIT is set for 1.5 V, then the voltage difference between U500 pins 37 and 38 must be 0.1 V before the current through R5875 is reduced. If U500 pin 40 is programmed for 4.5 V, then the difference of potential between pins 37 and 38 must exceed 0.3 V before current limiting begins. The voltage across R5875, where current sense occurs, can be determined by multiplying the voltage on U500, pin 40 by 0.067. When current is being limited, the output of the op-amp (U500, pin 42) begins shutting down the conduction of Q503 and Q504, reducing PA control voltage, and reducing drive to the final amplifier to, effectively, control the final amplifier's maximum current.

Forward Power Limiter

After the harmonic filter a parallel pair of microstrip lines form a forward power sensing directional coupler and detector. The output of this directional coupler/detector is a DC voltage that is proportional to the forward RF power from the final amplifier. During normal transmission, the DC voltage from the forward detect line to the RPCIC ranges from 2 to 5.0 V.

This voltage connects to U500 pin 9, the directional coupler buffer input.

The directional coupler's buffered output, U500 pin 8, is summed to pin 2 with the digital/analog buffer's output through R509 and R507, respectively. In typical operation, the closed loop operation of the circuit attempts to keep the voltage at U500 pin 2 a constant value of 3.2 V. The control amp will maintain this condition by increasing or decreasing the control amp output voltage. This control amp output voltage is routed to the LLA via transistors Q503 and Q504. The output of Q504 is designated "control voltage drive" and is routed to J1 pin 2 of the PA board.

Since control voltage drive controls the gain of the LLA, it determines the drive level to the following stages and thus the output power of the final amplifier. The output power of the final stage is detected by the directional coupler and is routed back to U500 pin 2 via the buffer and R507. Thus the loop is complete and forward power is maintained a constant value. The voltage at pin 2 will drop below 3.2 V during low line voltage conditions where the PA cannot produce rated power. Current limit and voltage control limit circuits will also affect the voltage at pin 2 as described in the following discussion on temperature sensing.

Temperature Sensing

The temperature-sensing circuit of the PA works with the RPCIC to protect the PA devices from excessively high temperatures. On the PA board, this circuit, (formed by resistors R5857, R5843, R5858, and thermistor RT5875), provides a temperature dependent voltage to the RPCIC via J1 pin 6. As the PA temperature increases, the resistance of RT5875 decreases, causing the voltage at pin 6 to increase. This voltage is routed to the RPCIC, U500 pin 13, which is the input to the thermistor buffer. The buffer's output on pin 12 is connected to pin 2 via resistor R508. Note that pin 2 is the control amp input and is a summing point for temperature, forward-power detect, and power set signals. If the PA temperature becomes high enough so that the voltage at pin 7 exceeds 3.2 V, the thermistor buffer starts supplying current to the node at pin 2. Due to the fixed output current of the power-set buffer, the control loop can maintain 3.2 V at pin 2 only by reducing the forward-power detect voltage and, therefore, reducing the PA output power. Since power output is reduced, the generated heat is reduced to a safe level. If temperature decreases, the power output of the PA gradually increases to its nominal value.

NOTE: Under severe environmental conditions, more than one circuit may be attempting to reduce power output at the same time (i.e., during high VSWR conditions, the current limiter may initially reduce power, but eventual heat buildup will cause further power reduction by the thermal cut-back circuit).

3.7.2.2 40-Watt Power Amplifier

3.7.2.2.1 Transmitter

The 40-Watt ASTRO Spectra power amplifier is discussed in the following text.

Transmit Low Level Amplifier (LLA)

NOTE: The minimum input drive level to the PA into P5850 is 30 mW. Refer to the synthesizer section if input drive is less than 30 mW.

The Low Level Amplifier, the first stage of the PA, provides a gain that is a function of a control voltage. This control voltage comes from the Regulator Power Control IC (RPCIC) on the command board. The magnitude of the control voltage depends on PA output power, temperature, and final amplifier current drain.

The LLA, Q5801, is unique in that its gain is controlled by varying the collector's current rather than its voltage. Q5801 and associated circuitry (Q5806, Q5800, R5805, and R5818) are best described as a voltage-controlled current source. This means that the collector current of Q5801 is controlled by the magnitude of the control voltage. Proper operation of the LLA can be checked by monitoring the voltage across the resistor R5805. The voltage should measure in the range of 0.1 to 1.0 V, depending on the value of control voltage. A 0.1-V reading corresponds to a low control voltage (1 to 5 V) and a 1.0-V reading corresponds to a high control voltage (up to control voltage limit).

Predriver Stage

The second stage of the PA, Q5803, is the predriver which amplifies the output of the LLA to a level sufficient to operate the driver device, Q5850. This stage amplifies the LLA output from, approximately, 250 mW in to 2.0 Watts out.

Driver Stage

The driver is a six-leaded 2.5- to 16-Watt device. It is driven by the predriver device through a matching circuit that consists of C5851, C5852, C5850, C5858, and L5850. L5851 and L5852 give the driver a zero-DC bias (required for the driver's Class-C operation). L5852, a ferrite bead, helps lower the driver base Q and prevent unwanted oscillations. The network of L5853, L5854, C5856, C5857, and R5850 provide A+ to the collector. L5853 and L5854 provide the DC path and block RF from coming up the DC line. R5850 resistively loads down the collector at low frequencies, preventing unwanted oscillations. C5856 and C5857 are bypass capacitors.

Final Stage

The final device is a six-leaded 15- to 50-Watt device and is driven by the driver through a quasi-low pass matching circuit that consists of C5853, C5854, C5855, C5875, C5876, and associated transmission lines. Base network, L5875, L5876, L5883, C5891, R5881, and R5882, provide the zero-DC bias required by the final device's Class-C operation. L5875, L5876, and L5883 provide the DC path from base to ground. C5891, in parallel with L5875, presents a high impedance at UHF frequencies, thus minimizing RF losses in the base network. R5881, R5882, and L5883 resistively load down the base at low frequencies, thus preventing unwanted oscillations. The collector DC network consists of L5878, L5879, R5879, R5880, R5883, R5884, R5875, C5881, C5883, C5884, C5885, C5886, C5893, and CR5875. This network provides the A+ voltage to the final while blocking RF from getting up the DC line. L5878 and L5879 provide the DC path and block RF. R5879, R5880, R5883, and R5884 resistively load down the final's collector at low frequencies and prevent unwanted oscillations. C5881, C5883, C5884, C3885, C5886 and C5893 are all bypass capacitors ranging from very low frequencies up to UHF frequencies. R5875 is the current-sense resistor. CR5875 protects against reverse polarity. Finally, the power goes through a low-pass matching network (C5877, C5878, C5887, C5892, C5880, and associated transmission lines) to the rest of the output network (Directional Coupler, Antenna Switch, and Harmonic Filter).

3.7.2.2.2 Antenna Switch and Harmonic Filter

Antenna Switch

The antenna switch's impedance inverter circuit, made up of C5923 and L5921, takes the place of a quarter-wave microstrip line. During transmission, Keyed 9.4 V forward-biases CR5921, producing low impedance on CR5921's anode and high impedance on the C5923/L5921 node. Effectively, this isolates the transmitted power from the receiver, C5922 couples the power to the harmonic filter and on to the antenna.

Total TX to RX isolation exceeds 45 dB from 450-512 MHz. The impedance inverter contributes approximately 35 dB to transmit isolation. A second shunt switch, made up of CR5922, L5922, and C5924, provides additional isolation. C5926 and C5927 block DC.

During RX, CR5920 has an OFF capacitance of approximately 1 pF, which is tuned out by L5904. CR5921 and CR5922, incorporated in the RX match, have similar OFF capacitances.

Harmonic Filter

The 40-Watt harmonic filter is a 7-pole, low-pass filter, consisting of screened plate capacitors and discrete inductors (L5924, L5925, and L5926) on a 35-mil alumina substrate. The filter's ground plane is attached to the PA printed circuit board with solder, while input and output connections are made via MP5901 and MP5902. The filter's primary function is to attenuate harmonic spurs generated by the transmitter. It also adds low-pass selectivity for the receiver. L5910, grounded through MP5903, protects the PA from static discharge.

NOTE: When removing any of the discrete coils, take care to avoid leaching the plate capacitor metallization. Removal of the entire hybrid is best accomplished by heating the hybrid/PC board assembly with a heat gun or heat blower until the solder joint reflows.

3.7.2.2.3 Power Control Circuitry

Command Board Circuitry

Inside U500, the Regulator Power Control IC (Figure 3-26), is an operational amplifier that has four inverting inputs, and one non-inverting input (at pin 44) which is the reference input for the entire power control loop of the power amplifier. The 3.2-V reference voltage at U500-44 is produced by dividing SW +5-V with the voltage-divider circuit, R514 and R515.

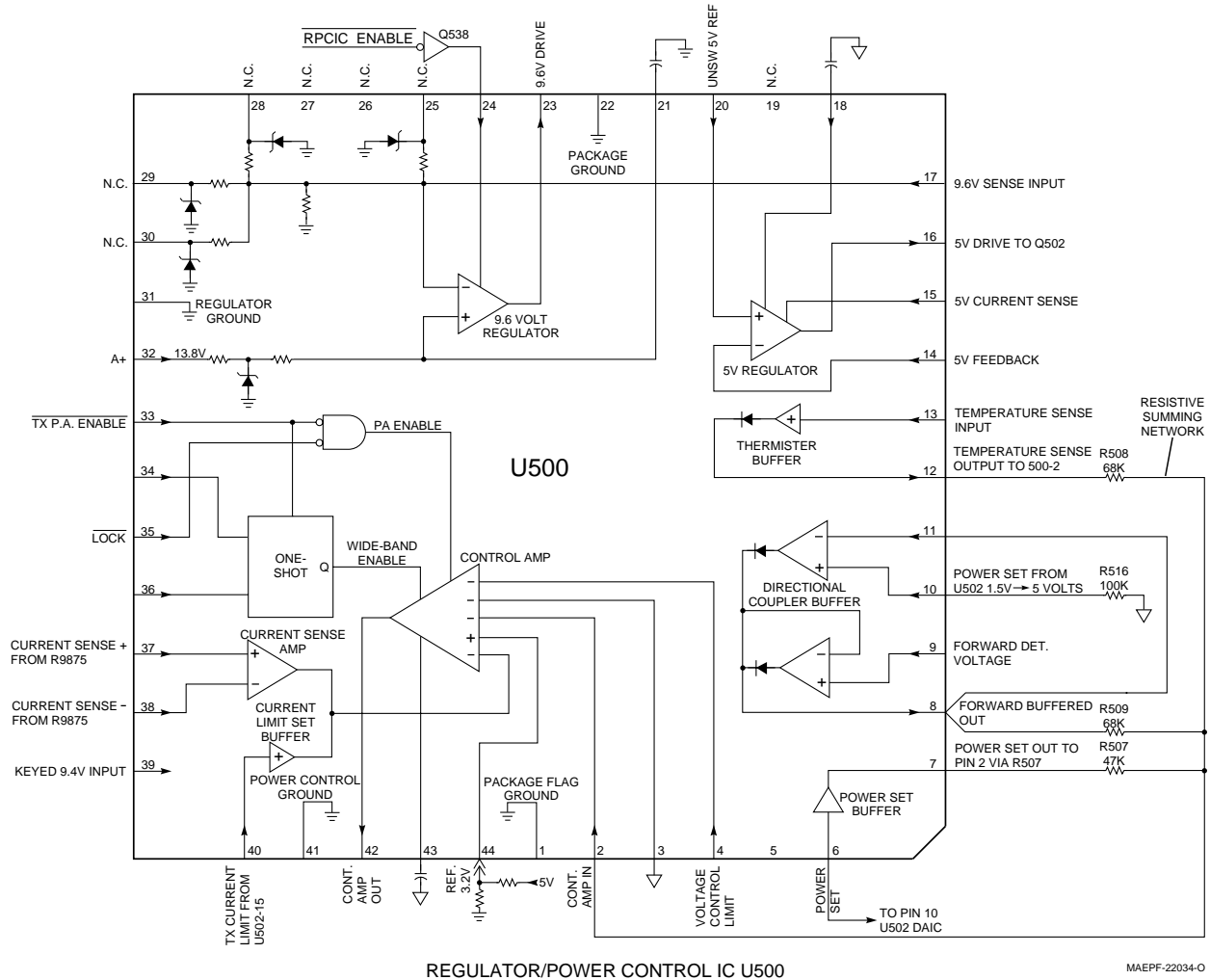

Figure 3-26. RPCIC Block Diagram

The power control loop is controlled by the microprocessor U204 on the VOCON board. Through the SLIC IC U206, the microprocessor enables the RPCIC by pulling TX PA ENABLE (U500 pin 33) low while the radio synthesizer is locked (U500 pin 35). U520 writes data to a digital-to-analog converter, U502, to change and control the power-set voltage from pin 10 of U502 to pin 6 of U500. The voltage on this line, 1.5 to 5 V, will be inversely proportional to the power out of the PA, with 5 V producing the lowest power output. This voltage may be set with RSS (Radio Service Software) or CPS (Customer Programming Software).

Control Voltage Limiter

R5807 and R5808 form a voltage divider that connects to control voltage drive. The output of this voltage divider is connected to the control-voltage-limit input (pin 4) of the RPCIC. If the voltage at this input reaches 3.2 V, then the control voltage will be clamped to a maximum value. For the 40-Watt UHF PA, this maximum value is 10 V. This voltage-control limit is set by the values of R5807 and R5808.

Current Limiter

U204, the processor on the VOCON board, sends data to U502, the digital-to-analog converter, to properly set the voltage on U502, pin 15, which is the TX CURRENT LIMIT control line to the RPCIC (U500, pin 40). Sixteen different voltages, ranging from 1.5 to 4.5 V, can be programmed from U502.

The collector current of the 40-Watt amplifier is monitored by sensing the voltage across R5875. CURRENT SENSE + connects to one end of R5875; CURRENT SENSE - connects to the other end. These lines connect to the command board on U500, Pins 37 and 38, respectively. If the TX CURRENT LIMIT is set for 1.5 V, then the voltage difference between U500, Pins 37 and 38 must be 0.1 V before the current through R5875 is reduced. If U500, pin 40 is programmed for 4.5 V, then the difference of potential between Pins 37 and 38 must exceed 0.3 V before current limiting begins. The voltage across R5875, where current sense occurs, can be determined by multiplying the voltage on U500, pin 40, by 0.067. When current is being limited, the output of the op-amp (U500, pin 42) begins shutting down the conduction of Q503 and Q504, reducing PA control voltage, and reducing drive to the final amplifier to, effectively, control the final amplifier's maximum current.

Forward Power Limiter

After the final amplifier, a parallel pair of microstrip lines form a forward power-sensing directional coupler. Because of increased coupling with frequency, C5903, L5902, C5904, L5903, and C5905 are used to compensate and filter out harmonics. CR5900 rectifies the signal. R5904, R5905, and RT5904 provide thermal compensation. During normal transmission, the DC voltage from the forward-detect line to the RPCIC ranges from 2 to 4.5 V. This voltage connects to U500, pin 9, the directional coupler buffer input.

The directional coupler's output, U500 pin 8, is summed to pin 2 with the digital/analog buffer's output through R509 and R507, respectively. Closed loop operation reduces the control amp's output (pin 42), reduces the power module's gain, and reduces power output to maintain the coupler buffer output (U500, pin 2) at 3.2 V regardless of the D/A voltage level. If the D/A voltage is high (4.5 V), little detected voltage is needed to keep pin 2 at 3.2 V, and the power, consequently, is low. If the D/A voltage is low (1.5 V), a large forward detected voltage is needed to keep pin 2 at 3.2 V and power, consequently, is at maximum value. The voltage at pin 2 drops below 3.2 V under proper operation during low line voltage conditions where the PA cannot produce rated power, or if, under any conditions, the control voltage or the final device current exceeds safe levels.

Temperature Sensing

The temperature-sensing circuit of the PA works with the RPCIC to protect the PA devices from excessively high temperatures. On the PA board, this circuit, formed by resistors R5878, R5876, R5877, and thermistor RT5875, provides a temperature-dependent voltage to the RPCIC via P0853, pin 7. As the PA temperature increases, the resistance of RT5875 decreases, causing the voltage at pin 7 to increase. This voltage is routed to the RPCIC, U500, pin 13, which is the input to the thermistor buffer. The buffer's output on pin 12 is connected to pin 2 via resistor R508. Note that pin 2 is the control amp input and is a summing point for temperature, forward-power detect, and power set signals. If the PA temperature becomes high enough so that the voltage at pin 7 exceeds 3.2 V, the thermistor buffer starts supplying current to the node at pin 2. Due to the fixed output current of the power-set buffer, the control loop can maintain 3.2 V at pin 2 only by reducing the forward-power detect voltage and, therefore, reducing the PA output power. Since power output is reduced, the generated heat is reduced to a safe level. If temperature decreases, the power output of the PA gradually increases to its nominal value. Temperature cutback should occur at about 140 F (60 C).

The temperature sense circuitry can easily be tested by placing an ordinary leaded 6.8k ohm resistor across RT5875. PA output power should drop significantly if this circuit is working properly.

NOTE: Under severe environmental conditions, more than one circuit may be attempting to reduce power output at the same time (i.e., during high VSWR conditions, the current limiter may initially reduce power, but eventual heat buildup will cause further power reduction by the thermal cut-back circuit).

3.7.3 800 MHz Band Power Amplifiers

3.7.3.1 15- and 35-Watt Amplifiers

3.7.3.1.1 Transmitter

The 15-Watt and 35-Watt ASTRO Spectra power amplifiers are discussed in the following text.

Transmit Buffer

The PA receives 18 to 23 dBm (60 to 200 mW) at the transmit injection (TX INJ) coax. The first stage, TX BUFFER, uses adaptive biasing which varies the base voltage inversely proportional to the input drive level. With Keyed 9.4 V (K9.4) ON and NO DRIVE, Q9800 base voltage should equal the voltage drop across CR9800. R9801 sets the diode current, and R9802 sets the base voltage referenced from CR9800. At the input, L9804, C9801, and C9800 are for matching while C9808 and R9806 prevent interfacing instability. L9800 is the base feed choke and L9801 is the collector choke. R9800 parallels L9800 for added stability. L9805, and C9803 are on the buffer's supply (K9.4) for stability. C9802 and L9802 are for output matching. L9803 and C9804 are added as a "suckout" for half carrier. Like the input, C9807 and R9805 were added at the output to help prevent interfacing instability. The power output of this stage should be greater than 325 mW (25 dBm).

The TX Buffer applies the modulated RF signal to pin 1 of U9850, the Power Amplifier Module, which is a 5-pin, 20-Watt, three-stage amplifier. The control voltage from the power control series-pass transistor, Q9500, controls the gain of the first two amplifier stages of U9850, through pin 2 and pin 3. Battery voltage (A +), connected to pin 4, powers the third stage.

Power Module

The power module (U9850) is the major gain block for both the 15- and 35-Watt amplifiers. The 50-ohm input and output impedances connect to adjacent power stages via 50-ohm microstrip lines. The parallel resistor, R9805, and capacitor C9807, on the input, reduce circuit response at lower frequencies and improve stability. The 350 mW (typical) input power is increased to approximately 15 Watts. The amplifier power is monitored by the power control IC on the command board and adjusted by controlling the voltage on U9850, Pins 2 and 3. A+ is applied directly to the final stage inside the power module via pin 4. No repairs can be made to the module; damaged or failed units must be replaced.



Caution

The power module leads will not tolerate undue stress; handle carefully when repairing.

Final Stage (35-Watt Only)

On the 15-Watt radio, the transmit RF signal from U9850, pin 5, is applied to the 50-ohm microstrip directional coupler. On the 35-Watt radio, the transmit RF signal is applied to the emitter of the final power amplifier Q9880 through the coupling capacitor C9856, the 50-ohm quarter-wave matching transmission line, and the matching capacitors C9875 and C9876. The 100-ohm coupling line, L9930, R9930, R9931, CR9930, and C9930 form an interstage power detector between U9850 and Q9880 to limit the drive into Q9880 to about 17 Watts. L9875, the emitter choke, is also the emitter DC return. The final power amplifier, Q9880, is a 45-Watt, 800 MHz, common-base NPN device. The Q9880 output match consists of C9877, C9878, a section of the 50-ohm microstrip line, C9879 and the DC blocking capacitor, C9883. L9876 isolates the RF signal from A+. C9880 and C9884 are signal frequency bypass capacitors. L9877 presents a high impedance at low RF frequencies; therefore the collector of Q9880 is resistively loaded by R9876 at low frequencies where the gain is much greater. C9881 and C9882 are low frequency bypass capacitors.

3.7.3.1.2 Antenna Switch and Harmonic Filter

Antenna Switch

35-Watt Power Amplifier:

The antenna switch's impedance inverter circuit, made up of C9922 and L9921, takes the place of a quarter-wave microstrip line. During transmission, K9.4-V forward-biases CR9921, producing a low impedance at its anode end, and a high impedance at the node of C9922 and L9921, to effectively isolate the transmitted power from the receiver. C9921 couples the power to the harmonic filter and on to the antenna.

The impedance inverter contributes approximately 30 dB to transmit isolation. Additional isolation is obtained by the series switch made up of CR9922, L9923, and associated DC bias components. During transmit, CR9922 is reverse-biased, thus creating a small series capacitor that is tuned out by L9923. C9925 is a DC blocking capacitor. The high impedance of the series arm works against the low impedance of the shunt arm (CR9921) to provide approximately 10 to 15 dB additional isolation. Total TX to RX isolation is in excess of 45 dB from 851-870 MHz. The preselector provides over 50 dB isolation from 806-824 MHz.

When receiving, CR9920 has an off capacitance of approximately 1 pF, which is tuned out by L9926. CR9921, with similar off capacitance, is incorporated in the RX match. CR9922 is forward-biased with an ON resistance of approximately 1 ohm. The signal passes CR9922 and through L9922, a series inductor used to complete the RX match. Capacitor C9929 blocks DC.

L9910, at the node of the antenna and harmonic filter, protects the PA from static discharge.

15-Watt Power Amplifier:

The theory for the 15-Watt antenna switch is exactly the same as the 35-Watt except that some of the components are labeled with different numbers. C9921, in the 15-Watt PA, is located after the harmonic filter.

L9922, at the node of the antenna and capacitor C9921, protects the PA from static discharge.

Harmonic Filter

The 15- and 35-Watt harmonic filters are 7-pole, low-pass filters implemented with screened plate capacitors and discrete inductors (L9911, L9912, and L9913) on a 35 mil (0.035") alumina substrate. The filter's ground plane is attached to the PA printed circuit board with solder, while input and output connections are made via "J"-straps MP9856 and MP9857. The filter's primary function is to attenuate harmonic spurs generated by the transmitter and to provide additional low-pass selectivity for the receiver.

NOTE: When removing any of the discrete coils, take care to avoid leaching the plate capacitor metallization. Removal of the entire hybrid is best accomplished by heating hybrid/PC board assembly with a heat gun or heat blower until solder joint reflows.

3.7.3.1.3 Power Control Circuitry

Command Board Circuitry

Inside U500, the Regulator Power Control IC (Figure 3-27), is an operational amplifier that has four inverting inputs, and one non-inverting input (at pin 44) which is the reference input for the entire power control loop of the power amplifier. The 3.2-V reference voltage at U500, pin 44, is produced by dividing SW + 5-V with the voltage-divider circuit, R514 and R515.

The power control loop is controlled by the microprocessor U204 on the VOCON board. Through the SLIC IC U206, the microprocessor enables the RPCIC by pulling TX PA ENABLE (U500 pin 33) low while the radio synthesizer is locked (U500 pin 35). U520 writes data to a digital-to-analog converter, U502, to change and control the power-set voltage from pin 10 of U502 to pin 6 of U500. The voltage on this line, 1.5 to 5 V, will be inversely proportional to the power out of the PA, with 5 V producing the lowest power output. This voltage may be set with RSS (Radio Service Software) or CPS (Customer Programming Software).

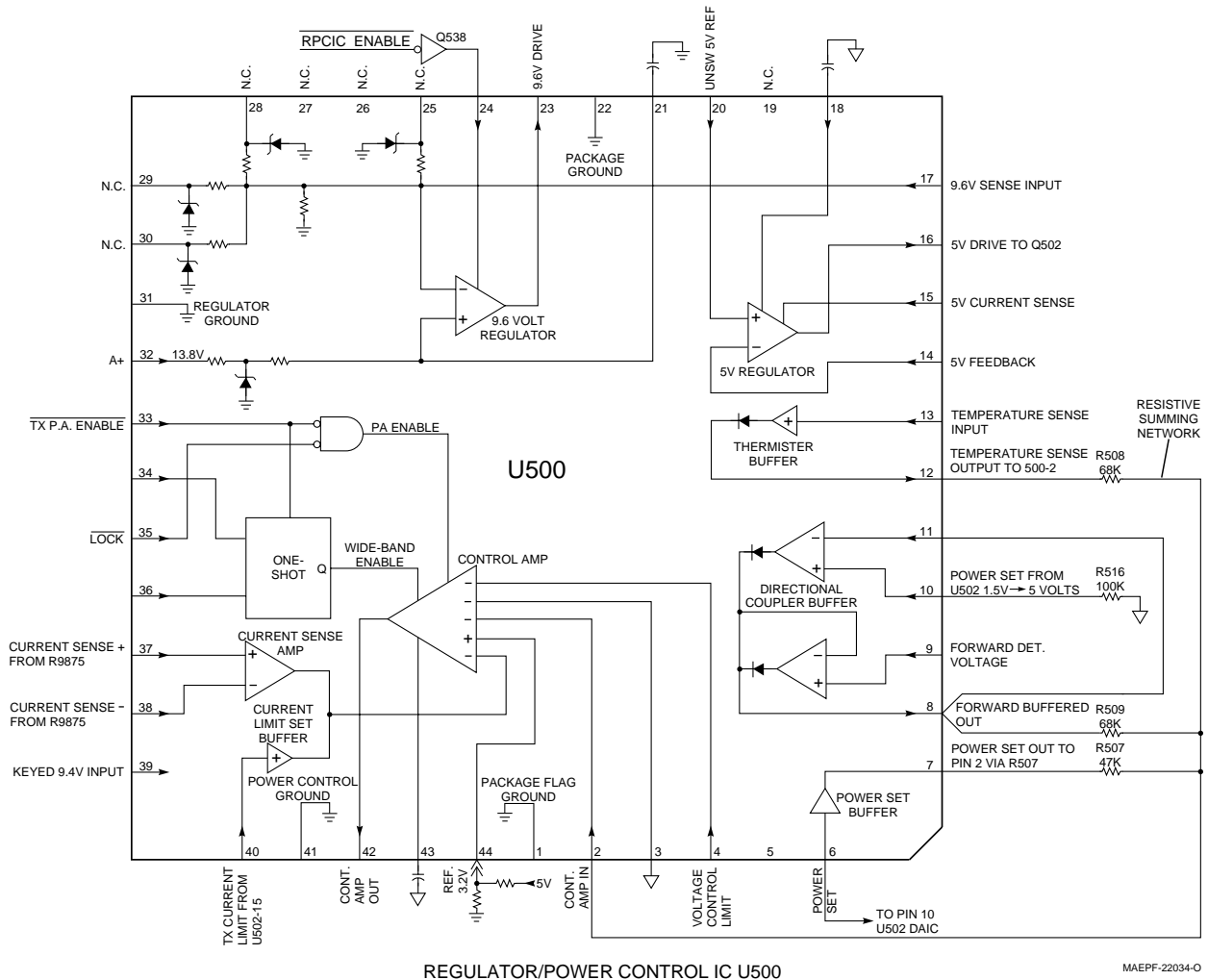

Figure 3-27. RPCIC Block Diagram

Power Module Control Voltage Limiter

R9562 and R9563 connect in series to the emitter of Q9500. The ratio of R9563 and R9562 feed a portion of the control voltage (U9850, Pins 2 and 3) to U500, pin 4. When pin 4 exceeds 3.2 V, the output of the control op-amp (U500, pin 42) is reduced. Eventually, this reduces the control voltage available to the power module (U9850).

The input RF power to the 45-Watt amplifier (Q9880) must stay below 17 Watts. Power is coupled from the inter-stage 50-ohm transmission line to a 100 ohm transmission line and rectified by CR9930 on the PA, producing a DC voltage on U500, pin 4. If this voltage exceeds 3.2 V, the output voltage on U500, pin 42, is reduced, lowering the control voltage and reducing U9850's gain until its RF output power is approximately 17 Watts.

Current Limiter

U204, the processor on the VOCON board, sends data to U502, the digital to analog converter, to properly set the voltage on U502, pin 15, which is the TX CURRENT LIMIT control line to the RPCIC (U500, pin 40). Sixteen different voltages, ranging from 1.5 to 4.5 V, can be programmed from U502.

The collector current of the 45-Watt final amplifier (in the 35-Watt PA only) is monitored by sensing the voltage across R9875. CURRENT SENSE + connects to one end of R9875 and CURRENT SENSE - connects to the other end. These lines connect to the command board on U500, Pins 37 and 38, respectively. If the TX CURRENT LIMIT is set for 1.5 V, then the voltage difference between U500, Pins 37 and 38 must be 0.1 V before the current through R9875 is reduced. If U500, pin 40 is programmed for 4.5 V, then the difference of potential between Pins 37 and 38 must exceed 3 V before current limiting begins. The voltage across R9875, where current sense occurs, can be determined by multiplying the voltage on U500, pin 40, by 0.067. When current is being limited, the output of the op-amp (U500, pin 42), begins shutting down the conduction of Q503 and Q504, reducing base drive to Q9500, reducing drive to the final amplifier to, effectively, control the final amplifier's maximum current.

Forward Power Limiter

The parallel pair of microstrip lines after the final amplifier, form a forward power sensing directional coupler. Because the coupling increases with frequency, the compensation network of L9806 and C9901 is used. CR9900 rectifies the signal, C9900 filters it, and R9905 and R9904 form a voltage divider. During normal transmission, the DC voltage from the forward detect line to the RPCIC ranges from 2 to 4.5 V. This voltage connects to U500, pin 9, the input to the directional coupler buffer.

The directional coupler's output, U500, pin 8, is summed to pin 2 with the digital/analog buffer's output through R509 and R507, respectively. Closed loop operation reduces the control amp's output (pin 42), reduces the power module's gain, and reduces power output to maintain the coupler buffer output (U500, pin 2) at 3.2 V regardless of the D/A voltage level. If the D/A voltage is high (4.5 V), little detected voltage is needed to keep pin 2 at 3.2 V, and the power, consequently, is low. If the D/A voltage is low (1.5 V), a large forward detected voltage is needed to keep pin 2 at 3.2 V and power, consequently, is at maximum value. The voltage at pin 2 drops below 3.2 V under proper operation during low line voltage conditions where the PA cannot produce rated power, or if, under any conditions, either the inter-stage power (in 35-Watt models only), the control voltage, or the final device current exceeds safe levels.

3.7.3.1.4 Temperature Sensing

When the radio is keyed, K9.4-V is applied to pin 5 of the PA connector and on one side of thermistor RT9560. As the temperature increases, the resistance of RT9560 decreases, creating more voltage across R9561. This temperature voltage is routed via PA connector pin 7 back to U500, pin 13, which is the input to a thermistor buffer. The thermistor buffer's output on pin 12 is summed to U500, pin 2, and passes through its scaling resistor, R508. When the temperature of the RT9560 causes its value to change enough that the voltage exceeds 3.2 V, the thermistor buffer starts supplying current to the node at pin 2. Due to the fixed output of the D/A, the control loop can maintain 3.2 V at pin 2 only by reducing power out and reducing the forward detected voltage. Since output is reduced, the generated heat is held to a safe level. As temp decreases, the power output of the PA gradually increases to its nominal value.

Q9515 and Q9510 switch A+ to one side of R9513. R9513 sums the A+ voltage into the same node as TEMPSENSE. Together with temp-sense the circuitry protects the power amplifier from unsafe operating conditions of high line and high temp.

NOTE: Under severe environmental conditions more than one circuit may be attempting to reduce power output at the same time (i.e., during high VSWR conditions, the inter-stage power limit may initially reduce power, but eventual heat build-up will cause further power reduction by the thermal cut-back circuit).

Notes

Chapter 4 Troubleshooting Procedures

4.1 ASTRO Spectra Procedures

This section will aid you in troubleshooting a malfunctioning ASTRO Digital Spectra radio. It is intended to be detailed enough to localize the malfunctioning circuit and isolate the defective component.

NOTE: Refer to [“4.2 ASTRO Spectra Plus Procedures” on page 4-10](#) for troubleshooting information specific to the ASTRO Spectra Plus radio.

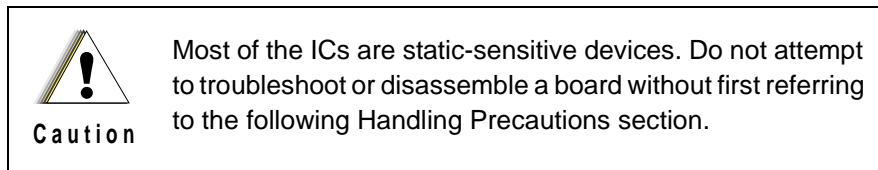

4.1.1 Handling Precautions

Complementary metal-oxide semiconductor (CMOS) devices and other high-technology devices, are used in this family of radios. While the attributes of these devices are many, their characteristics make them susceptible to damage by electrostatic discharge (ESD) or high-voltage charges. Damage can be latent, resulting in failures occurring weeks or months later. Therefore, special precautions must be taken to prevent device damage during disassembly, troubleshooting, and repair. Handling precautions are mandatory for this radio, and are especially important in low-humidity conditions. DO NOT attempt to disassemble the radio without observing the following handling precautions.

1. Eliminate static generators (plastics, Styrofoam, etc.) in the work area.
 2. Remove nylon or double-knit polyester jackets, roll up long sleeves, and remove or tie back loose hanging neckties.
 3. Store and transport all static-sensitive devices in ESD-protective containers.
 4. Disconnect all power from the unit before ESD-sensitive components are removed or inserted unless otherwise noted.
 5. Use a static-safeguarded workstation, which can be accomplished through the use of an anti-static kit (Motorola part number 01-80386A82). This kit includes a wrist strap, two ground cords, a static-control table mat and a static-control floor mat.
 6. Always wear a conductive wrist strap when servicing this equipment. The Motorola part number for a replacement wrist strap that connects to the table mat is 42-80385A59.
-

4.1.2 Voltage Measurement and Signal Tracing

In most situations, the problem circuit may be identified using a dc voltmeter, RF millivoltmeter, and oscilloscope (preferably with 100 MHz bandwidth or more). The “Recommended Test Equipment, Service Aids, and Tools” section in the *ASTRO Digital Spectra and Digital Spectra Plus Mobile Radios Basic Service Manual* (6881076C20) outlines the recommended tools and service aids which would be useful. Of special note are:

- 30-80370E06 Extender Cable which provides an extension cable for VOCON board connector J501 and command board connector P501.
- RPX-4725A Command and Control Service Cable Kit which provides extension cables for servicing digital and analog circuits.
- RPX-4724A RF Service Cable Kit which provides interface cables needed to service the RF boards.

In some cases dc voltages at probe points are shown in red on the schematics. In other areas diagrams are included to show time-varying signals, which should be present under the indicated circumstances. It is recommended that a thorough check be made prior to replacement of any IC or part. If the probe point does not have a signal reasonably close to the indicated one, a check of the surrounding components should be made prior to replacing any parts.

 Caution	<p>When checking a transistor or module, either in or out of circuit, do not use an ohmmeter having more than 1.5 Vdc appearing across test leads or use an ohms scale of less than x100.</p>
---	---

4.1.3 Power-Up Self-Check Errors

Each time the radio is turned on the MCU and DSP perform some internal diagnostics. These diagnostics consist of checking the programmable devices such as the FLASH ROMs, internal and external EEPROMs, SRAM devices, and ADSIC configuration bus checksum. At the end of the power-up self-check routines, if an error exists, the appropriate error code is shown on the display. Self-test errors are classified as either “fatal” or “non-fatal.” Fatal errors will inhibit user operation; non-fatal errors will not. For non-display radios, the error codes may be read using the Radio Service Software (RSS) from the SB9600 bus on the universal connector. [Table 4-1](#) lists self-check error codes, describes the codes, and recommends troubleshooting charts for investigating the cause of the failure.

Table 4-1. Power-Up Self-Check Error Codes

Error Code	Description	Troubleshooting Chart
01/02	External EEPROM checksum non-fatal error	Chart C.2 (p. 5-4), C.7 (p. 5-8)
01/81	ROM checksum failure	Chart C.6 (p. 5-7)
01/82	External EEPROM checksum failure	Chart C.2 (p. 5-4), C.7 (p. 5-8)
01/84	EEPROM is blank	Chart C.2 (p. 5-4), C.8 (p. 5-8)
01/88	RAM failure - Note: Not a checksum failure	Chart C.2 (p. 5-4), C.9 (p. 5-9)
01/90	General hardware failure	Chart C.2 (p. 5-4), C.5 (p. 5-7)
01/92	Internal EEPROM checksum failure	Chart C.10 (p. 5-9)

Table 4-1. Power-Up Self-Check Error Codes (Continued)

Error Code	Description	Troubleshooting Chart
02/81	DSP ROM checksum failure	Chart C.12 (p. 5-10)
02/82	DSP RAM 1 failure	Chart C.15 (p. 5-12)
02/84	DSP RAM 2 failure	Chart C.14 (p. 5-11)
02/88	DSP RAM failure - Note: Not a checksum failure	Chart C.13 (p. 5-11)
02/90	General DSP hardware failure (DSP start-up message not received correctly)	Chart C.16 (p. 5-12)
02/A0	ADSIC checksum failure	Chart C.11 (p. 5-10)
09/10	Secure option not communicating with radio	Chart C.17 (p. 5-13)
09/90	Secure hardware failure	Chart C.18 (p. 5-13)

In the case of multiple errors, the codes are logically OR'd and the results displayed. As an example, in the case of an ADSIC checksum failure and a DSP ROM checksum failure, the resultant code would be 02/A1. Following is a series of troubleshooting flowcharts which relate to each of these failure codes.

4.1.3.1 Power-Up Sequence

Upon RESET* going active, the MCU begins to execute code which is pointed to by the vector stored at \$FFFE, \$FFFF in the FLASH ROM. The execution of this code is as follows:

1. Initialize the MCU (U204).
2. The control head's MCU turns on the:
 - Green LED for the W3 model.
 - TX and Busy LEDs for the W4, W5, W7 and W9 models.
3. Initialize the SLIC (U206).
4. CONFIG register check. If the CONFIG register is not correct, the MCU will repair it and loop.
5. Start ADSIC/DSP:
 - Bring the ADSIC reset line high.
 - Wait 2ms.
 - Bring the DSP reset line high.
6. Start EMC:
 - Set the EMC wake-up line low (emc irq line).
 - Wait 5ms.
 - Set the EMC wake-up line high.
 - Wait 10ms.
 - Set the EMC wake-up line low (emc irq line).
 - Wait 5ms.

- Set the EMC wake-up line high.
- 7. Begin power-up self-tests.
- 8. Begin RAM tests:
 - External RAM (\$1800-3FFF).
 - Internal RAM (\$1060-\$1300).
 - External RAM (\$0000-\$0DFF).
 - Display 01/88 if failure.

The radio will get stuck here if the internal RAM is defective. The radio uses the internal RAM for stack. The RAM routines use subroutines. Thus, if the internal RAM is defective, the radio will get lost testing the external RAM.

- 9. Begin MCU (host μ C) ROM checksum test.
 - Fail 01/81 if this routine fails.
- 10. Begin DSP power-up tests. The MCU will try this five times before it fails the DSP test.
 - Check for HF2.
 - Fail 02/90 if 100ms.
 - Program the ADSIC.
 - Wait for the DSP power-up message.
 - Fail 02/A0 if 300ms.
 - Fail 02/A0 if wrong message from the DSP.
 - Wait for the DSP status information.
 - Fail 02/90 if 100ms.
 - Fail 02/88 if DSP RAM (U414) fails.
 - Fail 02/84 if DSP RAM U403 fails.
 - Fail 02/82 if DSP RAM U402 fails.
 - Fail 02/81 if DSP RAM fails.
 - Wait for the ADSIC checksum.
 - Fail 02/A0 if 100ms.
 - Fail 02/A0 if failure.
 - Wait for the first part of the DSP version number.
 - Fail 02/90 if 100ms.
 - Wait for the second part of the DSP version number.
 - Fail 02/90 if 100ms.
- 11. Checksum the codeplug.
 - Test internal codeplug checksums.
 - Fail 01/92 if failure.
 - Test external codeplug checksums.
 - Error 01/02 if non-fatal error; fail 01/82 if fatal error.

12. Power-up the EMC (if it is enabled in the codeplug).
13. Turn off the green LED.
14. Start up operating system.
15. Display for one second:
 - “SELF TEST” for the W3, model.
 - “SELF CHK” for the W4, W5, and W7 models.
 - “SELF CHECK” for the W9 models.
16. Turn off the green LED in the W3 model, or the TX and Busy LEDs in the W4, W5, W7, and W9 models.

Display errors if a fatal error exists at this time.

4.1.4 RF Board Troubleshooting

This information will help you troubleshoot the ASTRO Spectra Radio RF board. Use this information, along with the Theory of Operation, to diagnose and isolate the cause of failures. The principal tools needed to troubleshoot a circuit to the component level are the schematic and the Theory of Operation.

In addition to the schematic and theory, the following troubleshooting information identifies tests and checks designed to help isolate problems.

Prior to troubleshooting, it is important to review the Theory of Operation, including specific precautions and troubleshooting methods. Because much of the radio’s circuitry operates at high frequencies, measurements must be taken very carefully. Notes and cautions are added to the text to alert the reader to this need in areas of greatest sensitivity. However, the need for extreme care does exist in all measurements and tests.

4.1.4.1 Display Flashes “FAIL 001”

This display indicates a synthesizer “out-of-lock” condition. Check the dc power supplies for the correct voltages at the following locations:

Table 4-2. Voltage by Location

VOLTAGE	LOCATION	REMARKS
+5 Vdc	Q602 Collector	
+8.6 Vdc	Q603 Collector	
+5 Vdc +3.25 Vdc	J500 pin 1 J500 pin 2	Power from command board to reference oscillator

1. If any of the dc voltages are not correct, troubleshoot the source of the supplied power and correct the problem. If the voltages are correct, continue with the following checks.
2. Check U602, pin 19 for reference frequency, 0- to 9-V, square wave. If not correct, go to “Incorrect Values at U602, pin 19”; otherwise, continue with the following checks.
3. Check U602, pin 25 for reference frequency, 0- to 9-V, square wave. If not correct, go to “Incorrect Values at U602, pin 25 (MODULUS CONTROL)”; otherwise, continue with the following checks.
4. Check the negative steering line, J601, pin 4. If correct, continue with the following checks.

5. Check the positive steering line, J601, pin 1 or 2 for positive voltage between 1.0 and 8.0 V. If not correct, go to "Incorrect Voltage at Positive Steering Line"; otherwise, continue with the following checks.

NOTE: It is common for both steps 3 and 5 to be incorrect in an "out-of-lock" condition.

6. Check U602, pin 27 for a 1.5 Vp-p square wave whose frequency is determined in the following equation. If the values are not correct, go to "Incorrect Values at U602, pin 27."

Freq into U601-1 / Prescaler Modulus;
for example, $F_{in} / P = 455 \text{ MHz} / 255 = 1.77 \text{ MHz}$, or
 $F_{in} / (P+1) = 455 \text{ MHz} / 256 = 1.76 \text{ MHz}$.

NOTE: The frequency at U601, pin 40, is seldom exactly equal to " F_{in} " divided by " P " or " $P+1$ " because the prescaler is continuously changing from one division to the other. In the above example, P is 255 and $P+1$ is 256.

4.1.4.1.1 Incorrect Values at U602, Pin 19

1. If the reference frequency is not equal to 6.25 kHz (800/900 MHz) or 5.0 kHz (VHF/UHF), check U602-7 for 300 kHz, 0- to 9-V square wave. Then:
 - a. If 300 kHz is good, check the power to U602, pins 30 and 37. Also, check the serial data programming by pressing and holding the mode select button and probing pins 11, 12, and 13. The 0- to 5-V logic waveforms should appear similar to the following:

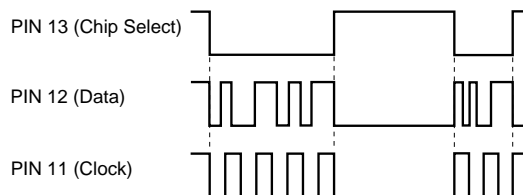

NOTE: The above waveforms are crude representations.

- b. If the programming appears normal and the power supplies have all checked out correctly, the out-of-lock condition is caused by a defective synthesizer IC (U602).
2. If 300 kHz is not present, check U602, pin 16, for 2.1 MHz, 1.5 Vp-p square wave.
 - a. If the signal is present and the power to the chip is normal, the condition is caused by a defective synthesizer IC (U602).
 - b. If the signal is not present, check for the same signal at U601, pin 18. If not on pin 18, check the reference oscillator output signal at U601, pin 21; it should be 16.8 MHz, 300 mVp-p. If the reference oscillator signal is present and the prescaler power supply voltages are normal, the prescaler IC(U601)is defective.
 - c. If the reference oscillator signal (16.8 MHz) is not present on U601, pin 21, check U600, pin 1 for 3.25 Vdc, pin 2 for ground, pin 3 for 16.8 MHz at 300 mVp-p, and pin 4 for 5 Vdc.

NOTE: Before concluding that the reference oscillator is defective, remove it from the board, power it up externally, and test it as an independent circuit.

4.1.4.1.2 Incorrect Values at U602 Pin 25 (MODULUS CONTROL)

If the frequency is not 6.25 kHz (or 5.0 kHz for VHF), verify the proper VCO pin-shift logic. See VCO block diagram (Figure 4-1 on page 4-14) for pin-shift logic. Also, check the VCO feedback for approximately -10 to 5 dBm at proper VCO frequency. Use the following table:

Table 4-3. Feedback Frequency Ranges

Band	VCO Feedback Frequency
VHF	TX Freq x 2 or RX Freq + 109.65 MHz
UHF	TX Freq or RX Freq + 109.65 MHz
800 MHz	TX Freq / 2 or (RX Freq - 109.65 MHz) / 2

If the VCO is running at approximately the correct level and frequency, proceed to “Incorrect Values at U602, pin 27.”

4.1.4.1.3 Incorrect Voltage at Positive Steering Line

Verify that the VCO is running; check VCO feedback for -10 to 0 dBm. Verify that the feedback buffer (if used) is working check U601-1.

4.1.4.1.4 Incorrect Values at U602, pin 27

Check prescaler (U601) operation; U601-40 should be:

EQUATION: $F = F_{VCO} / (P \text{ or } P+1)$

4.1.4.2 Review of Synthesizer Fundamentals

1. The synthesizer is a phase-locked loop system with a sample-and-hold phase detector.
2. In a locked system, the prescaler, in conjunction with the counters in the synthesizer chip, counts the VCO frequency down to the reference frequency. Think of this division process as a time domain function rather than frequency domain.
3. For each reference period (if using 6.25 kHz reference), you have 160 microseconds in which the VCO frequency is divided by N. Recall the equations:

EQUATION: $N = F_{VCO} / F_r$

EXAMPLE: $N = F_{VCO} / F_r = 450 \text{ MHz} / 6.25 \text{ kHz} \text{ or } 72,000$

EQUATION: $A = (\text{fractional remainder of } N/P) (P)$

EXAMPLE: $A = N/P = 72,000 / 255 = 282.3529; .3529 \times 255 \text{ Or } A=90$

EQUATION: $B = [N - \{A \times (P + 1)\}] / P$

EXAMPLE: $B = [72,000 - \{90 \times (255 + 1)\}] \text{ or } 192$

At 450 MHz, there are 72,000 counts of 2.22 nanoseconds each per reference period. When modulus control (MCT) is high, the VCO output is prescaled by 255 (see the diagram below). The output frequency of the prescaler is 1.765 MHz which corresponds to a period, per-cycle, of 567 nanoseconds. The "A" counter runs long enough to count down 90 cycles which equals 51 microseconds. When MCT is low, the prescaled output equals 1.758 MHz which corresponds to a period of 569 nanoseconds. The "B" counter counts 192 cycles which takes 109 microseconds. The total time required for proper loop division is thus 160 microseconds (the reciprocal of 6.25 kHz).

MODULUS CONTROL:	HI		LOW		HI		LOW		HI		LOW	
COUNTER:	A		B		A		B		A		B	
COUNTER RESET:	90		192		90		192		90		192	
PRESCALER DIVIDES BY:	255		256		255		256		255		256	
TIME (Microseconds):	51		109		51		109		51		109	
LOOP DIV. TIME (Sec):	----- 160 -----											

4.1.4.3 Second VCO Checks

1. Check for 300 kHz reference frequency at U601, pin 31.
2. Check for 0.5 to 4.0-V phase detector output at U601, pin 30.
3. Check for -12 to -16 dBm at 109.2 MHz feedback (U601, pin 26).
4. Check the divide-by-N test point for a 700-mV p-p waveform at 300 kHz (the second VCO frequency divided by 364). See the example below.

$$\frac{109.2 \text{ MHz}}{364} = 300 \text{ kHz}$$

NOTE: The second VCO circuit is external to U601 and, while it does depend on U601 for proper phase-locking, it should free-run, open-loop, at some frequency, if U601 fails. If the 8.8-V super filter and the oscillator are "dead," U601 is defective.

4.1.4.4 Troubleshooting the Back-End

Refer to ["Chart C.1 RF Board Back-End,"](#) on page 5-3.

4.1.5 Standard Bias Table

Table 4-4, below, outlines some standard supply voltages and system clocks which should be present under normal operation. These should be checked as a first step to any troubleshooting procedure.

Table 4-4. Standard Operating Bias

Signal Name	Nominal Value	Tolerance	Source
UNSW_B+	13.8 Vdc	11.0-16.6 Vdc	J501
SW_B+	13.8 Vdc	11.0-16.6 Vdc	J501
+5V	5.0 Vdc	±10%	J501
+5VA	5.0 Vdc	±10%	J501
RESET	5.0 Vdc	+0.7, - 1.0 Vdc	J501
POR*	5.0 Vdc	+0.7, - 1.0 Vdc	J501
DSP_RST*	5.0 Vdc	+0.7, -1.0 Vdc	U204
ADSIC_RST*	5.0 Vdc	+0.7, -1.0 Vdc	U204
DCLK	33.0000 MHz ^a	±500 ppM	U406
ODC	2.4 MHz	±30 ppM	ABACUS
ECLK	1.8432 MHz	±500 ppM	U204
IRQB*	8 kHz ^b	±500 ppM	U406
+5V	5.0 Vdc	±10%	U202
RX_5V ^c	5.0 Vdc	±10%	U106

- a. This number may vary due to the operating mode of the radio when it is measured. The ADSIC contains a divider which may divide the clock by a modulus of 2. Therefore, the actual frequency measured may be $\text{clock}/2^n$. The most common frequency will be 16.5000 MHz nominal.
- b. This 8 kHz clock will be present only after the MCU has successfully programmed the ADSIC after power-up. This is a good indication that the ADSIC is at least marginally operational.
- c. Receive mode only.

4.2 ASTRO Spectra Plus Procedures

This section will aid you in troubleshooting a malfunctioning ASTRO Digital Spectra Plus radio. It is intended to be detailed enough to localize the malfunctioning circuit and isolate the defective component.

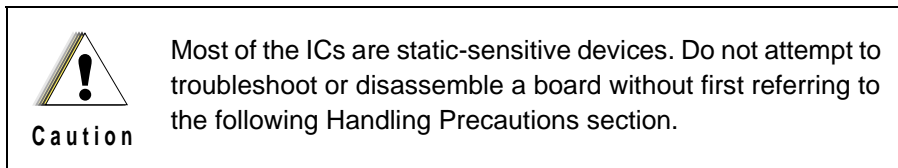

Please review [Section 4.1.1 on page 4-1](#) and [Section 4.1.2 on page 4-2](#) before continuing. Also, for information on troubleshooting the RF board, refer to [Section 4.1.4 on page 4-5](#).

4.2.1 ASTRO Spectra Plus Power-Up Self-Check Errors

Each time the radio is turned on the MCU and DSP perform some internal diagnostics. These diagnostics consist of checking the programmable devices such as the FLASH ROMs and SRAM devices. At the end of the power-up self-check routines any errors produced are recorded. If an error exists, use the Customer Programming Software (CPS) from the RS232 bus on front and rear of the radio to read the error code. [Table 4-5](#) lists self-check error codes, describes the codes, and gives the recommended corrective action.

Table 4-5. ASTRO Spectra Plus Power-Up Self-Check Error Codes

Error Code	Description	Corrective Action
01/02	FLASH ROM codeplug Checksum Non-Fatal Error	Reprogram the codeplug
01/12	Security Partition Checksum Non-Fatal Error	Send radio to depot
01/20	ABACUS Tune Failure Non-Fatal Error	Turn radio off, then on
01/22	Tuning Codeplug Checksum Non-Fatal Error	Send radio to depot
01/81	Host ROM Checksum Fatal Error	Send radio to depot
01/82	FLASH ROM codeplug Checksum Fatal Error	Reprogram the codeplug
01/88	External RAM Fatal Error --Note: Not a checksum error	Send radio to depot
01/90	General Hardware Failure Fatal Error	Turn radio off, then on
01/92	Security Partition Checksum Fatal Error	Send radio to depot
01/93	FLASHport Authentication Code Failure	Send radio to depot
01/98	Internal RAM Fail Fatal Error	Send radio to depot
01/A2	Tuning Codeplug Checksum Fatal Error	Send radio to depot
02/81	DSP ROM Checksum Fatal Error	Send radio to depot
02/88	DSP RAM Fatal Error --Note: Not a checksum error	Turn radio off, then on
02/90	General DSP Hardware Failure (DSP startup message not received correctly)	Turn radio off, then on

Table 4-5. ASTRO Spectra Plus Power-Up Self-Check Error Codes (Continued)

Error Code	Description	Corrective Action
09/10	Secure Hardware Failure	Turn radio off, then on
09/90	Secure Hardware Fatal Error	Turn radio off, then on

NOTE: In cases of multiple errors, the codes are logically OR'd and the results displayed.

4.2.2 ASTRO Spectra Plus Power-Up Self-Check Diagnostics and Repair

The following are additional action items to be utilized for the diagnosis and resolution of the error codes shown in [Table 4-5 on page 4-10](#):

- Error Code 01/02 This non fatal error will likely recover if the radio's power is cycled. In the event that this does not resolve the issue, the radio should be reflashed. As a last resort, the FLASH ROM U301 should be replaced.
- Error Code 01/12 The radio should be sent to the depot for reflashing of the security codeplug.
- Error Code 01/20 Cycling radio power should resolve this issue.
- Error Code 01/22 The radio should be sent to the depot for reflash of the tuning codeplug followed by re-tuning of the radio.
- Error Code 01/81 The radio should be sent to the depot for reflashing of the host code.
- Error Code 01/82 The radio should be sent to the depot for reflashing of the radio codeplug.
- Error Code 01/88 Reflashing of the radio should first be performed. If this fails to resolve the issue, then replacement of the SRAM U302 is necessary.
- Error Code 01/90 Cycle power to radio. Continued failure indicates a likely IC failure. In this event, radio should be sent to the depot for isolation and repair of the problem IC.
- Error Code 01/92 The radio should be sent to the depot for reprogramming of the security codeplug.
- Error Code 01/93 The radio should be sent to the depot for reflashing of the host code.
- Error Code 01/98 Send radio to the depot for replacement of the SRAM U302.
- Error Code 01/A2 The radio should be sent to the depot for reflashing of the tuning codeplug followed by re-tuning of the radio.
- Error Code 02/81 The radio should be sent to the depot for examination and/or replacement of either the FLASH U301, or the PATRIOT MCU/DSP U300.
- Error Code 02/88 Cycle power to the radio. If this does not fix the problem, then the radio should be sent to the depot for reflashing of the DSP code. Continued failure requires examination and/or replacement of the SRAM U302.
- Error Code 02/90 Cycle power to the radio. If this fails to fix the problem, then the radio should be sent to the depot for reflashing of the DSP code. Continued failure may require replacement of U300, the PATRIOT MCU/DSP.
- Error Code 09/10 Cycle power to the radio. If this fails then follow instructions as per troubleshooting chart C.32
- Error Code 09/90 Cycle power to the radio. If this fails then follow instructions as per troubleshooting chart C.32

4.2.3 ASTRO Spectra Plus Standard Bias Table

Table 4-6 outlines some standard supply voltages and system clocks which should be present under normal operation. These should be checked as a first step to any troubleshooting procedure.

Table 4-6. ASTRO Spectra Plus Standard Operating Bias

Signal Name	Nominal Value	Tolerance	Probe Point
SINE32K	32.768 kHz	+/- 400 ppm	R428
CKIH	16.8 MHz		C326
16_8MHz	16.8 MHz		TP401
POR	3.0 V	+/- 5%	J501-29
RESET_OUT	3.0 V	+/- 5%	J501
VCC1.8	1.80 Vdc	+/- 5%	R419
VCC3.0	3.0 Vdc	+/- 5%	R420
SW_B+	13.8 Vdc	11.0-16.6 Vdc	J501-35
VCC5	5.0 V	+/- 10%	J501-34

4.3 VCO Procedures

This section provides band-specific troubleshooting procedures for the VCO.

4.3.1 VHF Band

Use these instructions along with the Theory of Operation, the block diagram, and the schematic to help isolate failures: first, to the individual circuits, and finally, to the failing piece part.

4.3.1.1 VCO Hybrid Assembly

The VCO hybrid substrate is glued to the carrier board. The hybrid is not a field-repairable assembly. If a failure is indicated in this assembly, replace the complete hybrid. You will need a hot-air source to heat and soften the glue to separate the hybrid from the carrier board. If no hot-air source is available, replace the entire carrier board.

4.3.1.2 Out-of-Lock Condition

The probable cause of an out-of-lock condition is a failure in the synthesizer circuit. (See [Section 4.1.4.2 on page 4-7](#).) If the voltages on the AUX 1* and AUX 2* lines do not conform to [Table 4-7 on page 4-15](#), troubleshoot the synthesizer.

If the AUX 1* and AUX 2* voltages are correct but the synthesizer feedback level is not within the range indicated, troubleshoot the first buffer on the VCO carrier board. If no problem is found with the first buffer and the level out of the VCO is below that indicated on the block diagram, then replace the VCO assembly.

If the AUX 1* and AUX 2* voltages are correct and the synthesizer feedback level is correct but an out-of-lock condition persists, troubleshoot the synthesizer.

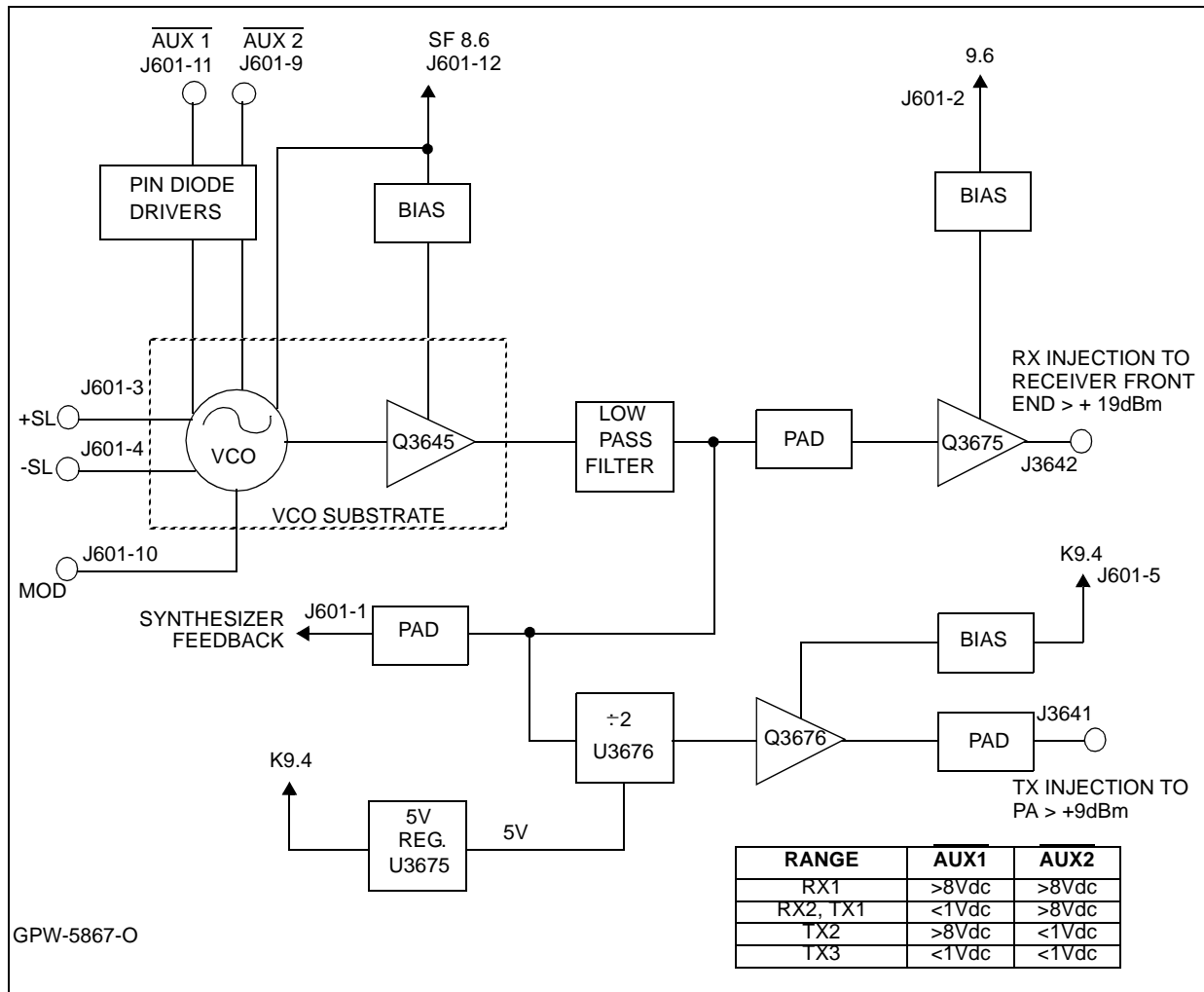

Figure 4-1. VCO Block Diagram—VHF Band

Table 4-7. VCO Frequency

Mode	AUX 1	AUX 2	Radio Freq (MHz)	VCO Freq (MHz)	Port Freq (MHz)	Port
VHF RANGE 1						
RX	HIGH	HIGH	136.00 - 158.35	245.65 - 268.00	245.65 - 268.00	(RX)
RX	LOW	HIGH	158.35 - 162.00	268.00 - 271.65	268.00 - 271.65	(RX)
TX	LOW	HIGH	136.00 - 145.20	272.00 - 290.40	136.00 - 145.20	(TX)
TX	HIGH	LOW	145.20 - 157.00	290.40 - 314.00	145.20 - 157.00	(TX)
TX	LOW	LOW	157.00 - 162.00	314.00 - 324.00	157.00 - 162.00	(TX)
VHF RANGE 2						
RX	HIGH	HIGH	146.00 - 166.15	255.65 - 275.80	255.65 - 275.80	(RX)
RX	LOW	HIGH	166.15 - 174.00	275.80 - 283.65	275.80 - 283.65	(RX)
TX	LOW	HIGH	146.00 - 150.00	292.00 - 300.00	146.00 - 150.00	(TX)
TX	HIGH	LOW	150.00 - 162.00	300.00 - 324.00	150.00 - 162.00	(TX)
TX	LOW	LOW	162.00 - 174.00	324.00 - 348.00	162.00 - 174.00	(TX)

4.3.1.3 No or Low Output Power (TX or RX Injection)

Use the test cables listed in the *Service Aids* section in the *ASTRO Digital Spectra and Digital Spectra Plus Mobile Radios Basic Service Manual* (6881076C20). Measure the power at the synthesizer feedback port - if it is not within the range specified in the block diagram, troubleshoot the first buffer. If failure is found in the first buffer, replace the defective component. If no failure is found in the first buffer and the level out of the VCO (measured with an RF millivoltmeter) is below that indicated in the block diagram, then replace the VCO assembly.

If the level at the synthesizer feedback port is within the indicated range, then troubleshoot the divider, RX, and TX buffer.

4.3.1.4 No or Low Modulation

Under standard test conditions with a 1 kHz tone injected and 4.5 kHz (± 50 Hz) deviation, there should be at least 0.8-V peak-to-peak present on J601, pin 10 (modulation input). (See the circuit board overlay for location.) If this level is not present, troubleshoot the audio circuitry, if it is present, check the VCO modulation circuitry.

4.3.2 UHF Band

Use these instructions along with the Theory of Operation, the VCO block diagram, and the schematic to help isolate failures, first to the individual circuits, and finally to the failing piece part.

4.3.2.1 VCO Hybrid Assembly

The VCO hybrid substrate is glued to the carrier board. The hybrid is not a field-repairable assembly. If a failure is indicated in this assembly, replace the complete hybrid. You will need a hot air source for heating and softening the glue to separate the hybrid from the carrier board. If no hot air source is available, replace the entire carrier board.

4.3.2.2 Out-of-Lock Condition

The probable cause of an out-of-lock condition is a failure in the synthesizer circuit. (See [Section 4.1.4.2 on page 4-7](#).) If the voltages on the AUX 1*, AUX 2*, or -8V lines at P0601 do not conform to the values shown in [Figure 4-2 on page 4-17](#), check the pin shift circuitry on the carrier board for proper operation. If no trouble is found, troubleshoot the synthesizer.

If the AUX1*, AUX2*, and -8-V voltages are correct at P0601, check the pin shift circuitry on the carrier board for proper operation. If no problem is found, probe the level of the synthesizer feedback at P0601-1 using an RF millivoltmeter. The meter should indicate greater than -15 dBm. If it does not, troubleshoot the synthesizer feedback circuitry; then troubleshoot the first buffer on the VCO carrier board. If no trouble is found and the level out of the VCO is below that indicated on the block diagram, then replace the VCO assembly.

If the AUX 1*, AUX2*, and -8-V voltages are correct and the synthesizer feedback level is correct but an out-of-lock condition persists, troubleshoot the synthesizer.

4.3.2.3 No or Low Output Power (TX or RX Injection)

Using an RF millivoltmeter, probe the synthesizer feedback level at P0601-1. If the meter indication is not greater than -15 dBm, troubleshoot the first buffer. If no failure is found and the level out of the VCO (measured into 50 ohms at the RF output of the hybrid) is below that indicated in the block diagram, then replace the VCO assembly.

If the level of synthesizer feedback at P0601-1 is correct, troubleshoot the doubler, second buffer, and then the RX/TX pin diode switch.

4.3.2.4 No or Low Modulation

Under standard test conditions with a 1 kHz tone injected and 4.5 kHz deviation, there should be 700 mV (RMS) $\pm 20\%$ present on P0601-10. If this level is not present, troubleshoot the modulation circuit on the carrier board and then troubleshoot the audio circuitry. If the proper level is present, troubleshoot the modulation circuitry on the VCO kit. If no failure exists, replace the VCO.

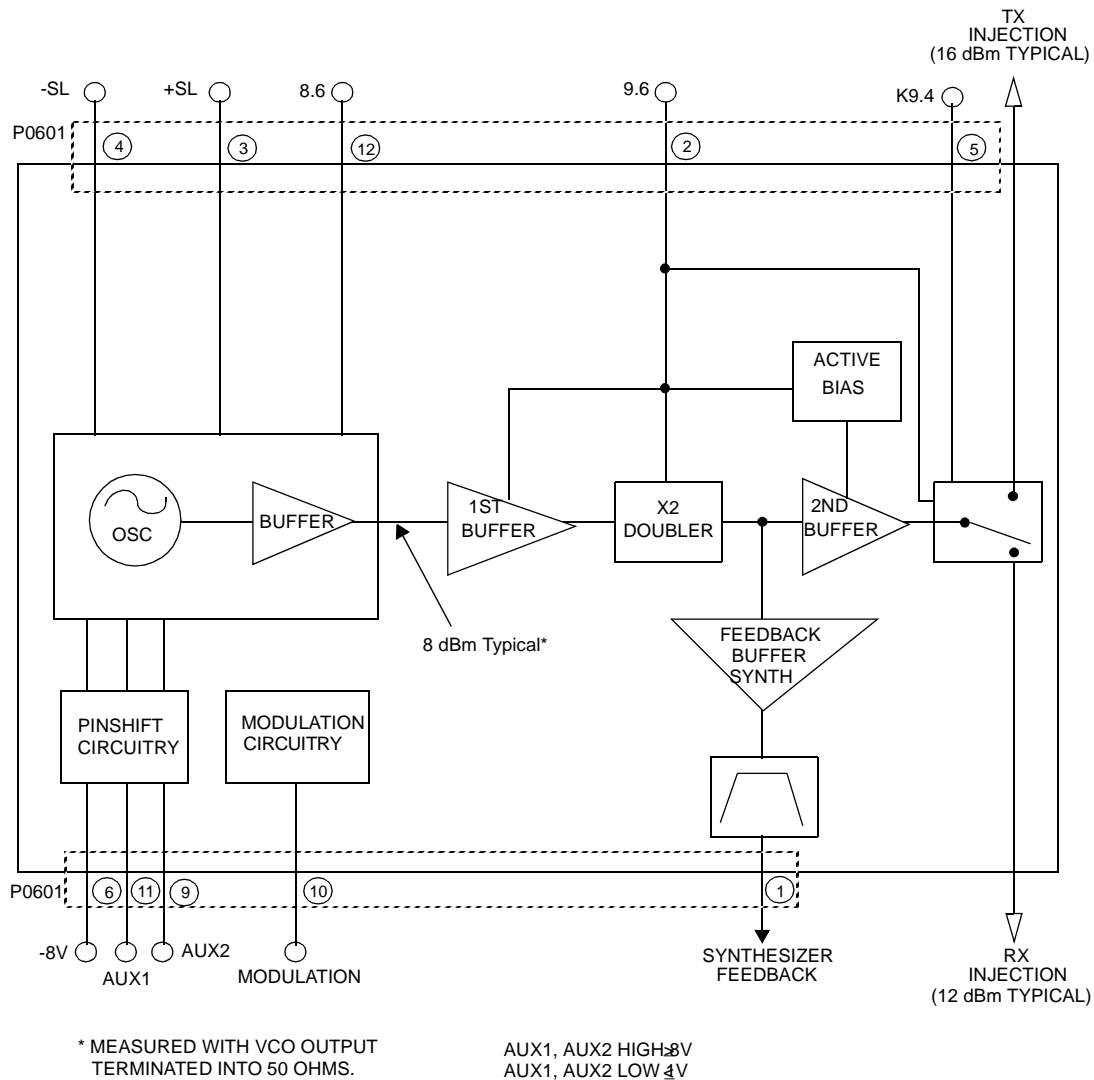

Figure 4-2. VCO Block Diagram—UHF Band

4.3.3 800 MHz Band

Use these instructions along with the Theory of Operation, the block diagram, and the schematic to help isolate failures, first, to the individual circuits, and finally to the failing piece part.

4.3.3.1 VCO Hybrid Assembly

The VCO hybrid substrate is glued to the carrier board. The hybrid is not a field-repairable assembly. If a failure is indicated in this assembly, replace the entire carrier board.

4.3.3.2 Out-of-Lock Condition

The probable cause of an out-of-lock condition is a failure in the synthesizer circuit. (See [Section 4.1.4.2 on page 4-7.](#)) If the voltages on the AUX 1* and AUX 2* lines do not conform to the table in [Figure 4-3](#), troubleshoot the synthesizer.

If the AUX 1* and AUX 2* voltages are correct but the synthesizer feedback level is not within the range indicated, troubleshoot the first buffer on the VCO carrier board. If no problem is found with the first buffer and the level out of the VCO is below that indicated on the block diagram, check J straps MP9656-MP9668. If no problem is found with these, replace the entire carrier board.

If the AUX 1* and AUX 2* voltages are correct and the synthesizer feedback level is correct but an out-of-lock condition persists, troubleshoot the synthesizer.

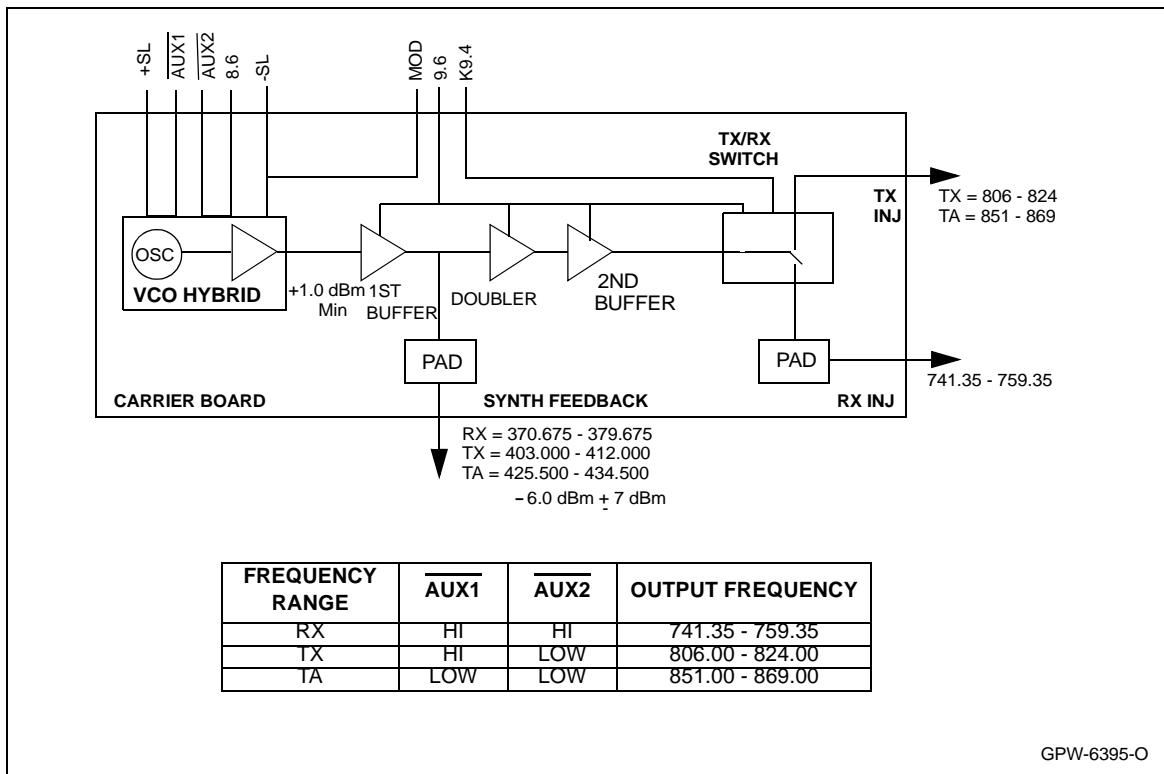

Figure 4-3. VCO Block Diagram—800 MHz Band

4.3.3.3 No or Low Output Power (TX or RX Injection)

Use the test cables listed in the "Service Aids" in the *ASTRO Digital Spectra and Digital Spectra Plus Mobile Radios Basic Service Manual* (6881076C20). Measure the power at the synthesizer feedback port-if it is not within the range specified in the block diagram, troubleshoot the first buffer. If failure is found in the first buffer, replace the defective component. If no failure is found in the first buffer and the level out of the VCO (measured with an RF millivoltmeter) is below that indicated in the block diagram check J straps MP9656-MP9668. If no problem is found with these, replace the entire carrier board.

If the level at the synthesizer feedback port is within the indicated range, then troubleshoot the doubler, second buffer, and PIN diode switch.

4.3.3.4 No or Low Modulation

Under standard test conditions with a 1 kHz tone injected and 4.6 kHz (± 250 Hz) deviation, there should be between 500 and 1000 mV present on J601, pin 10 (modulation input). (See the circuit board overlay for location.) If this level is not present, troubleshoot the audio circuitry. If it is present, check J601, pin 4 (NEG S.L.). The negative steering line should be -4.0 V (± 0.3 V). If this is not correct, check the negative steering line circuitry on the RF board and/or check R9651 and C9651 on the carrier board. If no problem is found, check J straps MP9656-MP9668. If no problem is found with these, replace the entire carrier board.

4.4 Receiver Front-End (RXFE)

This section provides band-specific troubleshooting procedures for the receiver front-end.

4.4.1 VHF Band

This information will help you troubleshoot the Spectra radio. Use this information, along with the Theory of Operation, to diagnose and isolate the cause of failures. The principle tools needed to troubleshoot a circuit to the component level are the schematic and the Theory of Operation.

In addition to the schematic and theory, this section includes a troubleshooting chart that will guide you through a sequence of tests and checks designed to isolate problems.

Prior to troubleshooting, it is important to review the Theory of Operation including specific precautions and troubleshooting methods.

4.4.2 UHF Band

This information will help you troubleshoot the Spectra radio. Use this information, along with the Theory of Operation, to diagnose and isolate the cause of failures. The principle tools needed to troubleshoot a circuit to the component level are the schematic and the Theory of Operation.

In addition to the schematic and theory, this section includes a troubleshooting chart that will guide you through a sequence of tests and checks designed to isolate problems.

Prior to troubleshooting, it is important to review the Theory of Operation including specific precautions and troubleshooting methods. Because much of the radio's circuitry operates at 500 MHz, measurements must be taken carefully.

4.4.3 800 MHz Band

This information will help you troubleshoot the Spectra radio. Use this information, along with the Theory of Operation, to diagnose and isolate the cause of failures. The principle tools needed to troubleshoot a circuit to the component level are the schematic and the Theory of Operation.

In addition to the schematic and theory, this section includes a troubleshooting chart that will guide you through a sequence of tests and checks designed to isolate problems.

Prior to troubleshooting, it is important to review the Theory of Operation including specific precautions and troubleshooting methods. Because much of the radio's circuitry operates at 800 MHz, measurements must be taken carefully.

4.5 Power Amplifier Procedures

This section provides band-specific troubleshooting procedures for the power amplifier.

4.5.1 VHF Band

4.5.1.1 High-Power Amplifier

This information will help you troubleshoot the Spectra radio. Use this information, along with the Theory of Operation, to diagnose and isolate the cause of failures. This section includes troubleshooting information that will help you test and check the circuits to localize and isolate problems.

Prior to troubleshooting, it is important to review the Theory of Operation, including specific precautions and troubleshooting methods. Because much of the radio's circuitry operates at VHF frequencies, measurements must be taken very carefully. Notes and cautions are added to the text to alert the reader to this need in areas of greatest sensitivity. However, the need for extreme care does exist in all measurements and tests at VHF frequencies.

4.5.1.1.1 General Troubleshooting and Repair Notes

Most of the common transmitter symptoms are not necessarily caused by failure of circuits on the PA board. Failure of command board or synthesizer circuits can disable the transmitter. The initial troubleshooting effort should be toward isolating the problem to one of these areas. If either the control voltage or keyed 9.4 V are zero, then the problem is likely to be in the control circuit or synthesizer. If those voltages are present, then the problem is more likely in the power amplifier circuit.

If, for diagnostic reasons, a chip component needs to be removed to facilitate testing, such as a series capacitor removed to allow for signal insertion, then the component(s) returned to the circuit should be new parts. The application of a soldering iron to many chip components will tend to cause leaching which could lead to failure.

If the harmonic filter is damaged and needs to be replaced, then removal and replacement requires the use of a hot-air source capable of reflowing the solder beneath the filter hybrid. When replacing it, add small amounts of fresh solder paste to the silver regions beneath the ceramic to assure adequate electrical ground contact. Save the original input and output connectors (J-straps); these are not included with the replacement kit. No tuning is required. The harmonic filter may be ordered separately, but if the PA kit is ordered a filter kit comes with the PA kit.

After a PA board is replaced, or if any power control circuitry components are replaced, readjust the power according to instructions in the *ASTRO Digital Spectra and Digital Spectra Plus Mobile Radios Basic Service Manual* (6881076C20).

Due to high operating frequencies, you must use specified Motorola parts when component replacement is necessary. Substitute components may not work. It is also critical that you use great care when replacing parts. Excessive solder or flux, longer than original leads on coax connectors, misorientation of parts and other commonly benign imperfections, may cause the radio's performance to degrade.

Bench testing the high-power Spectra PA is most easily accomplished if a Spectra control head, control cable, and power cable are available on the test bench. This greatly simplifies the troubleshooting as several supply voltages are provided by the command board. Proper operation of the command board circuitry can be simultaneously verified.

Begin troubleshooting by connecting an RF power meter and appropriate power load to the antenna connector. Connect the control cable and the power cable. Make sure the ignition sense lead is also connected to the positive lead of the power supply. Note that a regulated DC power supply capable of at least 30 A. is necessary to power a high-powered Spectra transmitter. Remove the radio bottom cover. Remove the PA shield by pulling straight up on the plastic handle. This must be done carefully, as the edge of the PA shield can damage components on the PA board if it is removed unevenly. Set the power supply to 13.4 V. The radio may now be turned on. All critical voltages may be measured at connector J1 from the top side of the PA board. A diagram of the connector pin-out, as viewed from the top side of the PA board, is shown in [Figure 4-4](#).

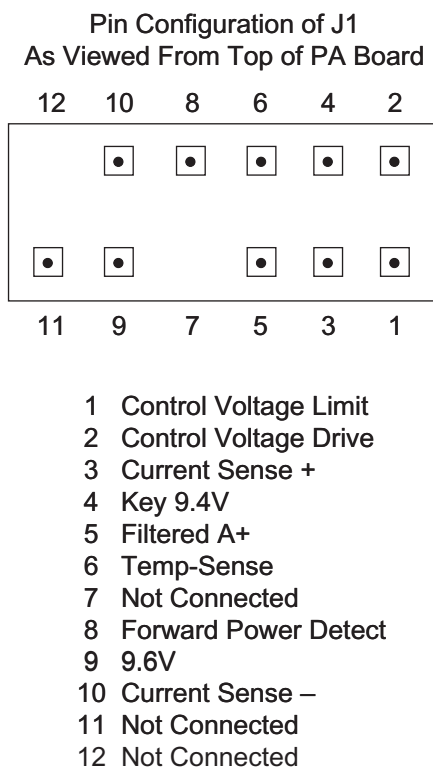

Figure 4-4. Connector Pin-Out—High-Power Amplifier

Key the transmitter. The RF power meter should read at least 100 Watts if it is calibrated. If power is low, the power set must be checked first before suspecting a defective PA or command board. This may be checked using a PC and RSS software. Alternatively, front panel programming may be used. Please refer to the *ASTRO Digital Spectra and Digital Spectra Plus Mobile Radios Basic Service Manual* (6881076C20) for programming instructions.

If correct power output can not be obtained by following the power set procedure outlined in the *ASTRO Digital Spectra and Digital Spectra Plus Mobile Radios Basic Service Manual* (6881076C20), it is possible that current limit may be improperly set. This can not be adjusted using front panel programming. A PC with RSS must be used. A simple way to check for current limit engagement is to temporarily short out the current sense resistor R3849 with a piece of 12- or 14-gauge wire. If full power is restored, then RSS must be used to properly set current limit.

If it is verified that both power set and current limit are not related to the power problem, then the synthesizer output must be checked. A milliwatt meter connected to the TX injection cable should indicate at least 10 mW of injection power during key-up. If this is not the case, refer to the RF board and VCO sections of this manual for troubleshooting procedures.

Table 4-8. Power Control DC Voltage Chart

LOCATION	RX MODE			TX MODE			COMMENTS
	LOW	TYP	HI	LOW	TYP	HI	
J1							
1		0		0	2.0	3.2	Control Voltage Limit
2		0		2.0	7.0	10.0	Drive Voltage
3	10.8	13.6	16.5	10.0	13.0	16.0	Current Sense +
4	0	0	0	9.2	9.4	9.8	Keyed 9.4
5	10.8	13.6	16.5	10.0	13.0	16.0	A+ to Command Board
6		0			1.2		Temp Sense (cutback begins at 3.3-V)
7	-	-	-	-	-	-	Key (no pin)
8		0		13.0	9.3	5.0	Forward Detect Voltage
9	10.8	13.6	16.5	10.0	13.0	16.0	A+ to Command Board
10	9.4	9.6	9.9	9.4	9.6	9.9	9.6-V Supply from Command Board Current Sense - (voltage delta 150 mV)
11	10.8	13.6	16.5	9.8	12.8	15.8	
12	-	-	-	-	-	-	Key (no pin or wire)
U500							
1	0	0	0	0	0	0	Ground
2		0			3.2		Control AMP Input
3	0	0	0	0	0	0	Control AMP Input (not used)
4		0		0	2	3.2	Control Voltage Limit (cutback at 3.3 V)
5		9			0		N.C.
6	1.5	3.0	4.5	1.5	3.0	4.5	Power Set from D-A (max power at 1.5 V)
7		0		1.5	3.0	4.5	Power Set Buffer Out
8		0		1.3	3.5	6.0	Coupler Buffer Out
9		0		1.3	3.5	6.0	Forward Detect Volt
10		0			0		Reflected Power Detect (not used)
11		0		1.3	3.5	6.0	Same as pin 8 (not used)
12		0		0	1.2	6.0	Thermister Buffer out (increases as PA gets hot)

Table 4-8. Power Control DC Voltage Chart (Continued)

LOCATION	RX MODE			TX MODE			COMMENTS
	LOW	TYP	HI	LOW	TYP	HI	
J1							
13		0		0	1.2	6.0	Thermister Buffer in
14		5.0			5.0		5-V Sense Input (follows pin 20 ± 0.1 V)
15	4.9	5.0	5.7	4.9	5.0	5.7	5-V Current Limit (limits at 5.7 V)
16	5.0	5.7	6.4	5.0	5.7	6.4	5-V Series Pass Drive (6.4 at max current)
17	9.5	9.6	9.9	9.5	9.6	9.9	9.6-V Sense Input
18		7			7		5-V Reg. Compensation Capacitor
19		5.7			5.7		N.C.
20	4.9	5.0	5.1	4.9	5.0	5.1	5-V Reference Input (UNSW5V)
21		1.2			1.2		9.6-V Reg. Compensation Capacitor
22		0			0		N.C.
23		0.9	9.6		1.2	9.6	9.6-V Series Pass Drive
24		2.9			3.3		Regulator Enable/Compensation
25	-	-	-	-	-	-	9.6-V Programming (N.C.)
26		0			0		N.C.
27		13.6			13.6		N.C.
28	-	-	-	-	-	-	9.6-V Programming (N.C.)
29	-	-	-	-	-	-	9.6-V Programming (N.C.)
30	-	-	-	-	-	-	9.6-V Programming (N.C.)
31	0	0	0	0	0	0	Ground
32	10.8	13.6	16.5	10.0	13.0	16.0	Decoupled A+
33	4.0	5.0			0	0.2	$\overline{\text{TX PA Enable}}$ (from U520-25)
34		0			1.3		Control AMP one-shot
35		0			0		$\overline{\text{Lock}}$ (5 V of Synth Out of Lock)
36		0			0.8		Control AMP one-shot
37	10.8	13.6	16.3	10.0	13.0	16.0	A+ (Current Sense +)
38	10.8	13.6	16.3	10.0	13.0	16.0	Current Sense - Voltage Delta 150 mV
39		0		9.2	9.4	9.8	Keyed 9.4-V in
40	1.5	3.0	4.5	1.5	3.0	4.5	Current Limit D-A (max current at 4.5 V)

Table 4-8. Power Control DC Voltage Chart (Continued)

LOCATION	RX MODE			TX MODE			COMMENTS
	LOW	TYP	HI	LOW	TYP	HI	
J1							
41	0	0	0	0	0	0	Ground
42		0			2.2	9.6	Control AMP Output (Approx 1/2-V Control)
43		1.3			7.0		Loop Integrator Capacitor
44		2.1			3.2		Control AMP Reference
Q0500E		13.0			13.0		A+ - CR0500 Drop
Q0501C		12.3			12.3		VQ0500E - B/E Drop
Q0501E		0.2			0.2		V pin 23 - B/E Drop
Q0503E		0			1.5		V pin 42 - B/E Drop (TX)
Q0503C		13.6			9.0		
Q0504B		13.6			12.9		A+ - B/E Drop (TX)

If the command board and synthesizer are functioning properly, the PA must be defective. Details on troubleshooting each circuit of the PA follow.

4.5.1.1.2 PA Functional Testing

NOTE: When setting or measuring RF power at VHF follow these guidelines to avoid measurement errors due to cable losses or non-50-ohm connector VSWR:

- All coaxial cables should be low loss and as short as possible.
- Attenuators and 50-ohm loads should have at least 25 dB return loss.
- Mini UHF to 'N' adapter, P/N 58803671321, should be used at the antenna connector. All other connectors should be 'N' type. No other adapters, barrel connectors, etc. should be used.

Maximum input level to the PA is 20 mW. Too much input power could result in damage to the LLA stage.

Methods of analyzing individual stages of the power amplifiers are detailed below. Most of the stages are Class-C and must be analyzed under relatively high RF power levels. The following information should help in isolation and repair of the majority of transmitter failures.

Testing Low-Level Amplifier (LLA) Circuitry

Proper operation of the LLA can be checked by monitoring the voltage across resistor R3804. The voltage should measure in the range of 0.4 V to 1.0 V, depending on the value of control voltage. A 0.4-V reading corresponds to a low control voltage (4 to 5 V) and a 1.0-V reading corresponds to a high control voltage (up to control voltage limit).

Measure LLA voltages according to [Table 4-9](#). If the DC bias conditions are correct, check to see if the LLA is providing drive power to Q3804. Do so by checking Q3804's collector current under normal drive conditions, as follows:

- Remove L3806 (be sure to reinstall after testing).
- Solder wires to the remaining pads. Place an ammeter in series with Q3804 collector.
- Check for 0.2 to 0.5 A. (depending on control voltage).

NOTE: With no RF drive to the input of the PA, Q3804 collector current should be zero.

Table 4-9. LLA and 2nd Stage Typical Voltages

CONTROL VOLTAGE	RF DRIVE OFF		RF DRIVE ON	
	8.0 V	6.0 V	8.0 V	6.0 V
Q3801	—	—	—	—
Base	0.7	0.7	0.7	0.5
Collector	8.3	9.0	8.0	8.8
Q3802	—	—	—	—
Base	7.7	8.4	7.5	8.2
Collector	2.0	1.4	2.3	1.2
Emitter	8.3	9.0	8.0	8.8
Q3806	—	—	—	—
Base	5.1	4.1	5.1	4.1
Collector	7.7	8.4	7.5	8.2
Emitter	4.5	3.4	4.5	3.4
Q3804	—	—	—	—
Base	0.5	0.5	0.0	0.2
Collector	9.6	9.6	9.5	9.5

NOTE: The LLA voltages change with different control voltages. An example of LLA voltages with control voltage equal to 8.0 V and 6 V is shown.

If Q3804 draws no current under normal conditions, then check for short or open input cable, or for defective parts in the matching circuitry between Q3801 and Q3804.

Testing Second Stage Circuitry Q3804

The second stage is a typical Class-C stage, except the base is biased with resistors R3809 and R3810. The necessary conditions for proper operation of this stage are input drive power, and bias conditions as shown in [Table 4-9](#).

NOTE: If it is necessary to replace Q3804, use a hot-air blower to remove and replace the part. It is important that the replacement device's case be properly soldered to its heatsink. Do so by flowing a small bead of solder around the rim of the device while it is clamped in the hot-air soldering device. The base and collector leads must be hand-soldered on the bottom side of the board.

Troubleshooting the Driver Stage (Q3805)

- Make sure A+ is at the collector.
- Check for shorts and/or opens in the matching circuitry. Also look for faulty components (cracked parts or parts not properly soldered).
- Measure the DC resistance from base to emitter. It should be less than 1-ohm. If not, check L3812 and L3809 for proper soldering, and replace if faulty.
- Check the current drain of Q3805. Remove L3811 and R3819 and solder wires to the pads. With an ammeter connected to these wires, check the collector current drain during transmit. It should be around 2.0 to 4.0 A. If current drain is low, go to next step.
- Desolder the base of Q3805 and bend its lead slightly so it does not contact the PC board. Check the base-emitter and base-collector junction diode voltages using the diode check function of a multimeter. Normal voltage drop should be near 0.6 V. If either junction is open or short circuited replace the device.

Analysis of the Final Amplifier Stage (Q3870 and Q3871)

Extreme care must be taken when troubleshooting the final amplifier due to the high RF currents and voltages present.

A visual inspection of the matching networks should be done first. Check for defective solder joints or burned components. Good soldering of the transistor device leads is essential. Make sure A+ voltage is reaching the collector of each final device.

Check the base-emitter and base-collector junctions of the final devices by removing L3930, L3933, R3859, and R4007. Using the diode check function of a multimeter, the junctions should have a forward voltage drop close to 0.6 V. Replace a final device if it has an open or shorted junction.

Capacitors C3860, C3861, C3862, and C3863 are placed on the bottom side of the PA board underneath the base leads of the final devices. Extreme care should be used when replacing these parts. Exact positioning is critical. Inspect for solder shorts on these capacitors before installing the PA board in the radio chassis.

Installation of the PA board into the radio chassis must be done carefully. The PC board's screws use a T-15 Torx bit and should be torqued to 12 to 14 inch-pounds. The device screws use a T-8 Torx bit and should be torqued to 12 to 14 inch-pounds. Always apply thermal compound to the area under the device flanges before installing the PA board.

Current drain of the final amplifier may be checked by measuring the voltage across R3849 during transmit. A voltage drop of 0.10 V to 0.15 V indicates the finals are drawing 10 to 15 A., which is within the acceptable range.

Testing the Antenna Switch and Harmonic Filter

Use care when replacing the harmonic filter. Removal of the filter is best accomplished by heating the filter/PC board assembly with a heat gun or heat blower until the solder joint reflows.

Verify that the receive path of the antenna switch and the harmonic filter are functioning by testing the receiver insertion loss as follows:

- Apply a low-level signal source at the antenna connector.
- Verify the conditions indicated in [Table 4-8 on page 4-23](#) for RX tests.
- Measure the power at the receive coax.
- If the difference between the input and output (insertion loss) is less than 1 db, then the circuitry is functioning properly.

Additional antenna switch tests are:

- Check CR3901, CR3902, and CR3903 using the diode check function of a multimeter. Note that CR3903 is on the bottom side of the board. This diode affects the receive path only and is unrelated to transmitter problems.
- Check for proper DC current through the PIN diodes; correct current is indicated if approximately 1.5 V is present at the junction of R3900 and L3900 during transmit..

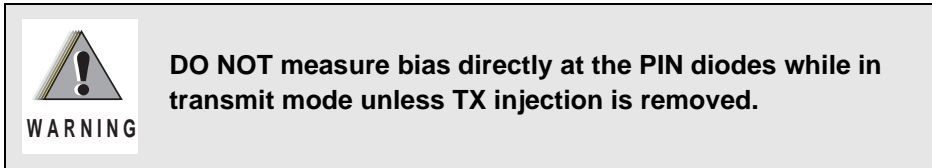

4.5.1.1.3 Power Control and Protection Circuitry

Localizing Problems to a Circuit

Power leveling and current limiting are set to values detailed in the *ASTRO Digital Spectra and Digital Spectra Plus Mobile Radios Basic Service Manual* (6881076C20). These values will vary from unit to unit, depending on the unique variations of each unit. If symptoms indicate that either of these circuits have failed, verify that the radio has been properly aligned before investigating the circuitry.

Temperature sense and control voltage limit are fixed by design and are not influenced by the alignment of the radio. If symptoms indicate that these circuits have failed, then troubleshoot the circuit.

The tests that follow are intended to provide a convenient means of verifying that a particular circuit is functioning properly. These tests will isolate the failure to a minimum number of components. Refer to the Theory of Operation and the schematic for information needed to identify the failed component(s).

Temperature Sense Circuit Test

Temporarily install a 2.2k ohm resistor in parallel with RT3842. Key the transmitter and monitor the output power. The power meter should read approximately one-half the rated power.

Control-Voltage-Limit Circuitry Test

Disconnect the transmitter injection cable from J3850. With all other connections in normal condition, key the transmitter and monitor the control voltage at J1 pin 2. If the voltage exceeds 9.0 V, troubleshoot the control voltage limit circuitry.

Current-Limiting Circuitry Test

When ready to adjust current limit, decrease the relative current limit value with the keyboard per instructions. After several decrements, the current limit should begin to reduce power in 0.5 to 1.0 Watt increments. After this test, reset the current limit to its original value. If the circuitry does not perform as indicated, troubleshoot the current limit circuitry.

Directional Coupler and Power-Leveling Test

The directional coupler combined with the RPCIC form a closed-loop power leveling circuit. This circuit keeps forward power essentially constant under variations of line voltage, frequency, and VSWR.

The directional coupler samples a small amount of forward power during transmit. This power is rectified by a detector diode CR3904. This rectified DC voltage is fed back to the RPCIC where it is compared to a reference voltage. An error voltage is generated which is ultimately translated into the control voltage via RPCIC circuitry and amplifiers Q503 and Q504 on the command board. Control voltage is routed to the LLA stage, thereby completing the feedback loop. In operation, the control loop tends to maintain the forward detected voltage constant versus frequency and line voltage variations. Proper operation can be observed by monitoring the forward detected voltage while varying the supply voltage from 13.4 to 16.1 V. Forward detected voltage should not change more than a few hundredths of a volt. Note that the forward power may not necessarily be level if one of the other protection circuits such as temp-sense or current limit is engaged.

NOTE: If any part of the power leveling circuitry is replaced, perform the power set procedure. See the *ASTRO Digital Spectra and Digital Spectra Plus Mobile Radios Basic Service Manual* (6881076C20) for details.

Miscellaneous Circuits and Notes

Diode CR3840 acts as a reverse protect diode. This diode also protects from over-voltage conditions, as it has a Zener breakdown voltage of approximately 28 V. When replacing this diode, care must be taken to place the diode with the cathode marking ring down (towards the PC board)

NOTE: The control voltage drive and K9.4 supplies from the command board are not current limited. A momentary short on either of these supplies will cause damage to transistors on the command board. Use caution when troubleshooting circuits that use these.

4.5.1.2 25/10 Watt Power Amplifier

This information will help you troubleshoot the Spectra radio. Use this information, along with the Theory of Operation, to diagnose and isolate the cause of failures. The principle tools needed to troubleshoot a circuit to the component level are the schematic and the Theory of Operation.

In addition to the schematic and theory, this section includes troubleshooting information that will help you test and check the circuits to localize and isolate problems.

Prior to troubleshooting, it is important to review the Theory of Operation, including specific precautions and troubleshooting methods. Because much of the radio's circuitry operates at high frequency, measurements must be taken very carefully. Notes and cautions are added to the text to alert the reader to this need in areas of greatest sensitivity

However, the need for extreme care does exist in all measurements and tests at high frequency.

4.5.1.2.1 General Troubleshooting and Repair Notes

Most of the common transmitter symptoms are caused by either failure of the power amplifier or a failure in the control circuitry. The initial troubleshooting effort should be toward isolating the problem to one of those two areas. If either the control voltage or keyed 9.4 V are zero, then the problem is likely to be in the control circuit. If those voltages are present, then the problem is more likely in the power amplifier circuit.

If, for diagnostic reasons, a chip component needs to be removed to facilitate testing, such as a series capacitor removed to allow for signal insertion, then the component(s) returned to the circuit should be new parts. The application of a soldering iron to many chip components will tend to cause leaching which could lead to failure.

After a PA board is replaced, or if any power control circuitry components are replaced, readjust the power according to instructions in the *ASTRO Digital Spectra and Digital Spectra Plus Mobile Radios Basic Service Manual* (6881076C20).

NOTE: Due to high operating frequencies, you must use specified Motorola parts when component replacement is necessary. Substitute components may not work. It is also critical that you use great care when replacing parts. Excessive solder or flux, longer than original leads on coax connectors, misorientation of parts, and other commonly benign imperfections may cause the radio's performance to degrade.

4.5.1.2.2 PA Functional Testing

To test the PA assembly for proper operation, perform the following steps:

1. Disassemble the PA assembly from the radio, leaving the power cable connected to the rear connector. Replace the PA shield and cover. Disconnect the coax connectors and the ribbon cable. Connect a power meter to the antenna port using minimum cable length.
 - a. When setting or measuring RF power, follow these guidelines to avoid measurement errors due to cable losses or non 25/10-ohm connector VSWR:
 - All cables should be very short and have Teflon dielectric.
 - Attenuators and 25/10-ohm loads should have at least 25 dB return loss.
 - Mini UHF to 'N' adapter, P/N 58-80367B21, should be used at the antenna connector. All other connectors should be 'N' type. No other adapters, barrel connectors, etc. should be used.
 - b. Maximum input level to the PA is 20 mW. Too much input power could result in damage to the LLA stage.
2. Apply the input power and DC voltages indicated in [Table 4-10](#) to the power amplifier assembly. To make the DC connections, use small spring-clips or make a test adapter similar to that shown in [Figure 4-5 on page 4-31](#).

Table 4-10. DC Voltages and Input Power Chart

Test	Keyed 9.4 V	CONTROL VOLTAGE DRIVE	POWER IN (mW)	A+ (V)
Transmit	9.4	See note ^a	10	13.4
Receive	0	0	0	13.4

a. Set initially to zero. Increase value until power equals 28 Watts or 9.2 V maximum. Do NOT exceed 9.2 V.

3. Apply the required input power via an adapter cable. For this application, non 'N' type connectors are acceptable.

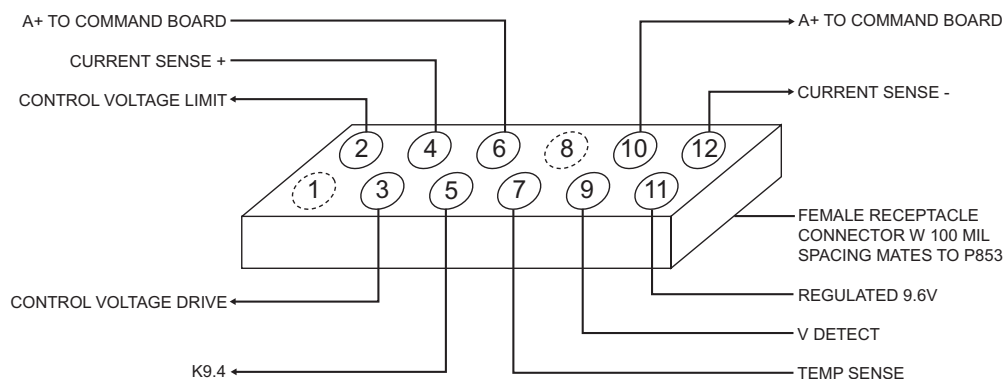

Figure 4-5. PA Test Adapter, 25/10 Watt Power Amplifier

4. With the applied control voltage drive initially at 0 V, slowly increase the voltage until power out equals 28 Watts. Power should rise smoothly with control voltage once the turn-on threshold is reached. Control voltage drive should not exceed 9.2 V.
5. If 9.2 V does not produce 28 Watts, then a failure exists in the power amplifier circuit.
6. Refer to the voltage chart (see Table 4-11). Measure the indicated voltages. If they are not within the limits shown in the chart, then a failure exists in the PA assembly.
7. If the voltages in the chart are correct, verify that the injection is at least 10 mW. (See the VCO troubleshooting section.)
8. If no failure is located from the previous checks, troubleshoot the power control circuitry.

Table 4-11. Power Control DC Voltage Chart

LOCATION	RX MODE			TX MODE			COMMENTS
	LOW	TYP	HI	LOW	TYP	HI	
P0853							
1	—	—	—	—	—	—	Key (no pin or wire)
2		0		0	2.0	3.2	Control Voltage Limit
3		0		2.0	7.0	9.2	Control Drive Voltage
4	10.8	13.8	16.6	10.4	13.4	16.2	Current Sense +
5	0	0	0	9.2	9.4	9.8	Keyed 9.4
6	10.8	13.8	16.6	10.4	13.4	16.2	A+ to Command Board
7		0			1.2		Temp Sense (cutback begins at 3.3 V)
8	—	—	—	—	—	—	Key (no pin)
9		0		1.5	3.5	5.0	Forward Detect Volt
10	10.8	13.8	16.6	10.4	13.4	16.2	A+ to Command Board
11	9.4	9.6	9.9	9.4	9.6	9.9	9.6-V Supply from Command Board
12	10.8			9.8	13.1	15.9	Current Sense - (voltage delta 150 mV)

Table 4-11. Power Control DC Voltage Chart (Continued)

LOCATION	RX MODE			TX MODE			COMMENTS
	LOW	TYP	HI	LOW	TYP	HI	
U0500							
1	0	0	0	0	0	0	Ground
2		0			3.2		Control AMP Input
3	0	0	0	0	0	0	Control AMP Input (not used)
4		0		0	2	3.2	Control Voltage Limit (cutback at 3.3 V)
5		0			0		N.C.
6	1.5	3.0	4.5	1.5	3.0	4.5	Power Set from D-A (max power at 1.5 V)
7		0	0	1.5	3.0	4.5	Power Set Buffer Out
8		0		1.3	3.5	6.0	Coupler Buffer Out
9		0		1.3	3.5	6.0	Forward Detect Voltage
10		0			0		Reflected Power Detect (not used)
11		0		1.3	3.5	6.0	Same as pin 8 (not used)
12		0		0	1.2	6.0	Thermister Buffer out (increases as PA gets hot)
13		0		0	1.2	6.0	Thermister Buffer in
14		5.0			5.0		5-V Sense Input (follows pin 20 ± 0.1 V)
15	4.9	5.0	5.7	4.9	5.0	5.7	5-V Current Limit (limits at 5.7 V)
16	5.0	5.7	6.4	5.0	5.7	6.4	5-V Series Pass Drive (6.4 at max current)
17	9.5	9.6	9.9	9.5	9.6	9.9	9.6-V Sense Input
18		7			7		5-V Reg. Compensation Capacitor
19		5.7			5.7		N.C.
20	4.9	5.0	5.1	4.9	5.0	5.1	5-V Reference Input (UNSW5-V)
21		1.2			1.2		9.6-V Reg. Compensation Capacitor
22		0			0		N.C.
23		0.9	9.6		1.2	9.6	9.6-V Series Pass Drive
24		2.9			3.3		Regulator Enable/Compensation
25	—	—	—	—	—	—	9.6-V Programming (N.C.)
26		0			0		N.C.
27		13.6			13.6		N.C.
28	—	—	—	—	—	—	9.6-V Programming (N.C.)

Table 4-11. Power Control DC Voltage Chart (Continued)

LOCATION	RX MODE			TX MODE			COMMENTS
	LOW	TYP	HI	LOW	TYP	HI	
29	—	—	—	—	—	—	9.6-V Programming (N.C.)
30	—	—	—	—	—	—	9.6-V Programming (N.C.)
31	0	0	0	0	0	0	Ground
32	10.8	13.6	16.5	10.0	13.0	16.0	Decoupled A+
33	4.0	5.0			0	0.2	TX PA Enable (from U520-25)
34		0			1.3		Control AMP one-shot
35		0			0		Lock (5-V of Synth Out of Lock)
36		0			0.8		Control AMP one-shot
37	10.8	13.6	16.3	10.0	13.0	16.0	A+ (Current Sense +)
38	10.8	13.6	16.3	10.0	13.0	16.0	Current Sense - Voltage Delta 150 mV (30 Watt only)
39		0		9.2	9.4	9.8	Keyed 9.4-V in
40	1.5	3.0	4.5	1.5	3.0	4.5	Current Limit D-A (max current at 4.5 V)
41	0	0	0	0	0	0	Ground
42		0			2.2	9.6	Control AMP Output (Approx 1/2-V Control)
43		1.3			7.0		Loop Integrator Capacitor
44		2.1			3.2		Control AMP Reference
Q0500E		13.0			13.0		A+ - CR0500 Drop
Q0501C		12.3			12.3		VQ0500E - B/E Drop
Q0501E		0.2			0.2		V pin 23 - B/E Drop
Q0503E		0			1.5		V pin 42 - B/E Drop (TX)
Q0503C		13.6			9.0		
Q0504B		13.6			12.9		A+ - B/E Drop (TX)

NOTE: For antenna switch transmit bias conditions, RF drive must be removed from PA.

Table 4-12. Antenna Switch DC Voltage Chart

LOCATION		TYPICAL RX	TYPICAL TX NO PRE- DRIVE	COMMENTS
CR3920	ANODE	0	1.6	
	CATHODE	0	0.8	
CR3921	ANODE	0	0.8	
	CATHODE	—	—	
CR3922	ANODE	0	<0.8	
	CATHODE	—	—	

4.5.1.2.3 Localizing Problems

Failure locations often can be determined by externally measured symptoms. Basic symptoms are noted below with probable failure locations.

1. Low Power and High Current
 - Check for improper load conditions caused by high VSWR external to the radio.
 - Check output coax and mini-UHF connector.
 - Check harmonic filter.
 - Check output impedance-matching circuitry from the final device to the harmonic filter.
2. Low Power and Low Current
 - If control voltage drive is equal to 9.2 V, then check per the above.
 - If control voltage drive is less than 9.2 V, then check the control circuitry.
3. Power Intermittently Low (or Zero) and Current Less than 1 A. When Power Drops
 - Check LLA stage.
4. Power Zero and Current Greater Than 3 A.
 - Check harmonic filter, antenna switch, and matching circuits beyond final stage.
5. Power Zero and Current Between 1 and 3 A.
 - Check driver and/or final stages.
6. Power Zero and Current Less Than 1 A.
 - Check LLA/driver circuitry.

4.5.1.2.4 Isolating Failures

Methods of analyzing individual stages of the Power Amplifiers are detailed below. Most of the stages are Class C and must be analyzed under relatively high RF power levels. Generators capable of such levels may not be available in all service shops, therefore the tests below are arranged in order of ascending power. This tends to allow the preceding stage to be the source of RF power for testing the next stage.

Testing Low-Level Amplifier (LLA) Circuitry

The required DC and RF conditions are defined in [Table 4-10 on page 4-30](#). Measure LLA voltages according to [Table 4-13](#).

If the above DC bias conditions are correct, check to see if the LLA is providing drive power to the pre-driver, Q3804. Do so by checking Q3804's collector current under normal drive conditions, as follows:

- Remove R3810 and L3806 (Be sure to reinstall after testing.)
- Solder wires to the remaining pads.
- Place an ammeter in series with Q3804 collector.
- Check for 0.1 to 0.5 A. (depending on control voltage).

NOTE: With no RF drive to the input of the PA, Q3804's collector current should be zero.

Table 4-13. LLA and Driver Typical Voltages

CONTROL VOLTAGE	RF DRIVE OFF		RF DRIVE ON	
	9.2 V	6.0 V	9.2 V	6.0 V
Q3801	—	—	—	—
Base	0.7	0.7	0.7	0.5
Collector	8.3	9.0	8.0	8.8
Q3802	—	—	—	—
Base	7.7	8.4	7.5	8.2
Collector	2.0	1.4	2.3	1.2
Emitter	8.3	9.0	8.0	8.8
Q3806	—	—	—	—
Base	5.1	4.1	5.1	4.1
Collector	7.7	8.4	7.5	8.2
Emitter	4.5	3.4	4.5	3.4
Q3804	—	—	—	—
Base	0.5	0.5	0.0	0.2
Collector	13.8	13.8	13.3	13.4

If Q3804 draws no current under normal conditions, then check for shorted or open input cable, or for defective parts in the input network or matching circuitry between Q3801 and Q3804. If all of the above check out OK, then replace Q3801.

Testing Driver Circuitry

The driver is a typical Class-C stage, except the base is biased with resistors R3809 and R3810. The necessary conditions for proper operation of this stage are input drive power, and bias conditions as shown in [Table 4-13 on page 4-35](#).

NOTE: If it is necessary to replace Q3804, use a hot-air blower to remove and replace the part. It is important that the replacement device's case be properly soldered to its heatsink. Do so by flowing a small bead of solder around the rim of the device while it is clamped in the hot-air soldering device. The base and collector leads must be hand-soldered on the bottom side of the board.

Troubleshooting the Final Device

- Make sure A+ is at the final's collector; if not, check for shorts and/or opens.
- Check the matching circuitry for shorts and/or opens. Also, check for faulty components.
- Measure the resistance from base to emitter; it should be less than 1 ohm. If not, check for proper soldering on L3852 and L3851; replace faulty component(s).
- Current drain on the final device should be >3.5 A. for 25-Watt operation. If low current, go on to the next step.
- Remove L3851 from the board and check the base-emitter and base-collector junction diode drops. Normal voltage drop should be between 0.4 and 1.0 V. If either junction is outside this range, replace the final device.

NOTE: When replacing either the driver or final device, apply thermal compound on the heatsink surface. Torque the screws to the correct value; see the *ASTRO Digital Spectra and Digital Spectra Plus Mobile Radios Basic Service Manual* (6881076C20).

Testing the Antenna Switch and Harmonic Filter

Verify that most of this circuit is functioning properly by testing the receiver insertion loss as follows:

- Apply a low-level signal source at the antenna connector.
- Apply the conditions indicated in [Table 4-10 on page 4-30](#) for RX tests.
- Measure the power at the receive coax.
- If the difference between the input and output (insertion loss) is less than 1 dB, then the circuitry is functioning properly.
- Additional antenna switch tests are:
 - Check CR3920, CR3921, and CR3922 with an ohmmeter for forward and reverse continuity.
 - In the transmit mode, adjust control voltage for 28 Watts at the antenna connector. Check for less than 10 mW at the end of the receive input cable. If power exceeds 10 mW, then check CR3922 and associated circuitry. Receiver sensitivity can degrade if power at this port exceeds 10 mW.

- Check for proper DC current through the PIN diodes; correct current is indicated if approximately 1.5 V is present at the junction of C3900 and L3900 during transmit mode.

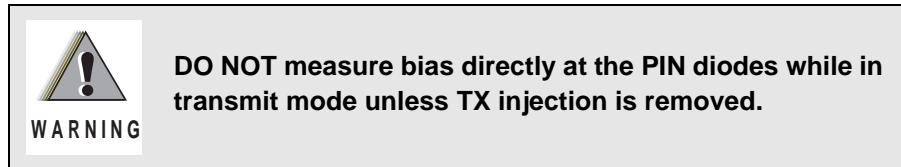

4.5.1.2.5 Power Control and Protection Circuitry

Localizing Problems to a Circuit

Power leveling and current limiting are set to values detailed in the *ASTRO Digital Spectra and Digital Spectra Plus Mobile Radios Basic Service Manual* (6881076C20). These values will vary from unit to unit, depending on the unique variations of each unit. If symptoms indicate that either of these circuits have failed, verify that the radio has been properly aligned before investigating the circuitry.

Temperature sense and control voltage limit are fixed by design and are not influenced by the alignment of the radio. If symptoms indicate that these circuits have failed, then troubleshoot the circuit.

The tests that follow are intended to provide a convenient means of verifying that a particular circuit is functioning properly. These tests will isolate the failure to a minimum number of components. Refer to the Theory of Operation and the schematic for information needed to identify the failed component(s).

Temperature Sense Circuit Test

Temporarily install a 6.8k ohm resistor in parallel with RT3876. Key the transmitter and monitor the output power. The power meter should read approximately one-half the rated power (12 Watts).

Control-Voltage-Limit Circuitry Test

Disconnect the transmitter injection from the internal transceiver chassis. This will require removal of the power amplifier assembly. With all other connections in normal condition, key the transmitter and monitor the control voltage. If the voltage exceeds 9.2 V, troubleshoot the control voltage limit circuitry.

Current-Limiting Circuitry Test

Refer to Chapter 6 of the *ASTRO Digital Spectra and Digital Spectra Plus Mobile Radios Basic Service Manual* (6881076C20) for current limit setting instructions. When ready to adjust current limit, decrease the relative current limit value with the keyboard per instructions. After several decrements, the current limit should begin to reduce power. After this test, reset the current limit to its original value. If the circuitry does not perform as indicated, troubleshoot the current limit circuitry.

Power-Leveling Circuitry Test

With the radio connected for power measurements, vary the line voltage from 12.5 to 16 V. The power should not vary more than 2 Watts. At a line voltage of 13.8 V, vary the frequency using the three test modes. If power varies more than 2 Watts, measure the detected voltage on P0853, pin 9. If this voltage varies more than 0.2 V over line and frequency variations, the power control circuitry (most of which is located on the command board) may be malfunctioning. If the detected voltage varies less than 0.2 V, the problem is likely in diode CR3900, the harmonic filter, the antenna switch, or the output coax. Check continuity through the 12-pin DC connector P0853 on the PA board; check digital/analog circuitry, and check 5-V regulator operation. See [Table 4-12 on page 4-34](#), DC Voltage Chart, for typical values.

With the radio connected for power measurements and a disconnected TX injection coax, the detected voltage at P0853, pin 9, should measure approximately 1.3 V.

NOTE: If any part of the power leveling circuitry is replaced, perform the power set procedure. See the *ASTRO Digital Spectra and Digital Spectra Plus Mobile Radios Basic Service Manual* (6881076C20) for details.

4.5.1.3 50 Watt Power Amplifiers

This information will help you troubleshoot the ASTRO Spectra radio. Use this information, along with the Theory of Operation, to diagnose and isolate the cause of failures. The principle tools needed to troubleshoot a circuit to the component level are the schematic and the Theory of Operation.

In addition to the schematic and theory, this section includes troubleshooting information that will help you test and check the circuits to localize and isolate problems.

Prior to troubleshooting, it is important to review the Theory of Operation, including specific precautions and troubleshooting methods. Because much of the radio's circuitry operates at high frequency, measurements must be taken very carefully. Notes and cautions are added to the text to alert the reader to this need in areas of greatest sensitivity. However, the need for extreme care does exist in all measurements and tests at high frequency.

4.5.1.3.1 General Troubleshooting and Repair Notes

Most of the common transmitter symptoms are caused by either failure of the power amplifier or a failure in the control circuitry. The initial troubleshooting effort should be toward isolating the problem to one of those two areas. If either the control voltage or keyed 9.4 V are zero, then the problem is likely to be in the control circuit. If those voltages are present, then the problem is more likely in the power amplifier circuit.

If, for diagnostic reasons, a chip component needs to be removed to facilitate testing, such as a series capacitor removed to allow for signal insertion, then the components (s) returned to the circuit should be new parts. The application of a soldering iron to many chip components will tend to cause leaching which could lead to failure.

After a PA board is replaced, or if any power control circuitry components are replaced, readjust the power according to instructions in the *ASTRO Digital Spectra and Digital Spectra Plus Mobile Radios Basic Service Manual* (6881076C20).

NOTE: Due to high operating frequencies, you must use specified Motorola parts when component replacement is necessary. Substitute components may not work. It is also critical that you use great care when replacing parts. Excessive solder or flux, longer than original leads on coax connectors, misorientation of parts, and other commonly benign imperfections may cause the radio's performance to degrade.

4.5.1.3.2 PA Functional Testing

To test the PA assembly for proper operation, perform the following steps:

1. Disassemble the PA assembly from the radio, leaving the power cable connected to the rear connector. Replace the PA shield and cover. Disconnect the coax connectors and the ribbon cable. Connect a power meter to the antenna port using minimum cable length.
 - a. When setting or measuring RF power, follow these guidelines to avoid measurement errors due to cable losses or non-50-ohm connector VSWR:
 - All cables should be very short and have Teflon dielectric.
 - Attenuators and 50 ohm loads should have at least 25dB return loss.
 - Mini UHF to 'N' adapter, P/N 58-803671321, should be used at the antenna connector. All other connectors should be 'N' type. No other adapters, barrel connectors, etc. should be used.
 - b. Maximum input level to the PA is 20 mW. Too much input power could result in damage to the LLA stage.
2. Apply the input power and DC voltages indicated in [Table 4-14](#) to the power amplifier assembly. To make the DC connections, use small spring clips or make a test adapter similar to that shown in [Figure 4-6 on page 4-40](#).

Table 4-14. DC Voltages and Input Power Chart

Test	Keyed 9.4 V	CONTROL VOLTAGE DRIVE	POWER IN (mW)	A+ (V)
Transmit	9.4	See note ^a	10	13.4
Receive	0	0	0	13.4

a. Set initially to zero. Increase value until power equals 28 watts or 9.2 V maximum. Do NOT exceed 9.2 V.

3. Apply the required input power via an adapter cable. For this application, non 'N' type connectors are acceptable.
4. With the applied control voltage initially at 0 V, slowly increase the voltage until power out equals 55 Watts. Power should rise smoothly with control voltage once the turn-on threshold is reached. Control voltage should not exceed 8.0 V.
5. If 8.0 V does not produce 55 Watts, then a failure exists in the power amplifier circuit.
6. Refer to the voltage chart (see [Table 4-15 on page 4-40](#)). Measure the indicated voltages. If they are not within the limits shown on chart, then a failure exists in the PA assembly.
7. If the voltages in the chart are correct, verify that the injection is at least 10 mW (see the VCO Troubleshooting Section).

8. If no failure is located from the previous checks, troubleshoot the power control circuitry.

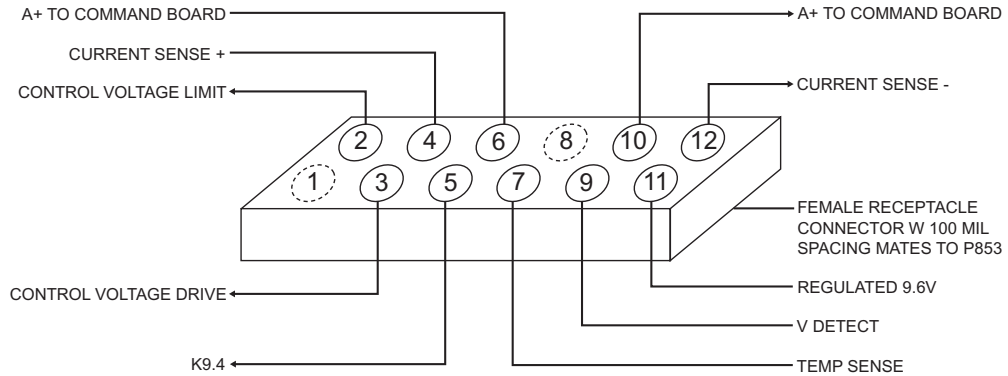

Figure 4-6. PA Test Adapter, 50 Watt Power Amplifier

Table 4-15. Power Control DC Voltage Chart

LOCATION	RX MODE			TX MODE			COMMENTS
	LOW	TYP	HI	LOW	TYP	HI	
P0853							
1	—	—	—	—	—	—	Key (no pin or wire)
2		0		0	2.0	3.2	Control Voltage Limit
3		0		2.0	7.0	9.2	Control Drive Voltage
4	10.8	13.8	16.6	10.4	13.4	16.2	Current Sense +
5	0	0	0	9.2	9.4	9.8	Keyed 9.4
6	10.8	13.8	16.6	10.4	13.4	16.2	A+ to Command Board
7		0			1.2		Temp Sense (cutback begins at 3.3 V)
8	—	—	—	—	—	v	Key (no pin)
9		0		1.5	3.5	5.0	Forward Detect Volt
10	10.8	13.8	16.6	10.4	13.4	16.2	A+ to Command Board
11	9.4	9.6	9.9	9.4	9.6	9.9	9.6-V Supply from Command Board
12	10.8			9.8	13.1	15.9	Current Sense - (voltage delta 150 mV)
U0500							
1	0	0	0	0	0	0	Ground
2		0			3.2		Control AMP Input
3	0	0	0	0	0	0	Control AMP Input (not used)

Table 4-15. Power Control DC Voltage Chart (Continued)

LOCATION	RX MODE			TX MODE			COMMENTS
	LOW	TYP	HI	LOW	TYP	HI	
4		0		0	2	3.2	Control Voltage Limit (cutback at 3.3 V)
5		0			0		N.C.
6	1.5	3.0	4.5	1.5	3.0	4.5	Power Set from D-A (max power at 1.5 V)
7		0	0	1.5	3.0	4.5	Power Set Buffer Out
8		0		1.3	3.5	6.0	Coupler Buffer Out
9		0		1.3	3.5	6.0	Forward Detect Voltage
10		0			0		Reflected Power Detect (not used)
11		0		1.3	3.5	6.0	Same as pin 8 (not used)
12		0		0	1.2	6.0	Thermister Buffer out (increases as PA gets hot)
13		0		0	1.2	6.0	Thermister Buffer in
14		5.0			5.0		5-V Sense Input (follows pin 20 \pm 0.1 V)
15	4.9	5.0	5.7	4.9	5.0	5.7	5-V Current Limit (limits at 5.7 V)
16	5.0	5.7	6.4	5.0	5.7	6.4	5-V Series Pass Drive (6.4 at max current)
17	9.5	9.6	9.9	9.5	9.6	9.9	9.6-V Sense Input
18		7			7		5-V Reg. Compensation Capacitor
19		5.7			5.7		N.C.
20	4.9	5.0	5.1	4.9	5.0	5.1	5-V Reference Input (UNSW5-V)
21		1.2			1.2		9.6-V Reg. Compensation Capacitor
22		0			0		N.C.
23		0.9	9.6		1.2	9.6	9.6-V Series Pass Drive
24		2.9			3.3		Regulator Enable/Compensation
25	—	—	—	—	—	—	9.6-V Programming (N.C.)
26		0			0		N.C.
27		13.6			13.6		N.C.
28	—	—	—	—	—	—	9.6-V Programming (N.C.)
29	—	—	—	—	—	—	9.6-V Programming (N.C.)
30	—	—	—	—	v	—	9.6-V Programming (N.C.)
31	0	0	0	0	0	0	Ground
32	10.8	13.6	16.5	10.0	13.0	16.0	Decoupled A+

Table 4-15. Power Control DC Voltage Chart (Continued)

LOCATION	RX MODE			TX MODE			COMMENTS
	LOW	TYP	HI	LOW	TYP	HI	
33	4.0	5.0			0	0.2	TX PA Enable (from U520-25)
34		0			1.3		Control AMP one-shot
35		0			0		Lock (5-V of Synth Out of Lock)
36		0			0.8		Control AMP one-shot
37	10.8	13.6	16.3	10.0	13.0	16.0	A+ (Current Sense +)
38	10.8	13.6	16.3	10.0	13.0	16.0	Current Sense - Voltage Delta 150 mV (30 Watt only)
39		0		9.2	9.4	9.8	Keyed 9.4-V in
40	1.5	3.0	4.5	1.5	3.0	4.5	Current Limit D-A (max current at 4.5 V)
41	0	0	0	0	0	0	Ground
42		0			2.2	9.6	Control AMP Output (Approx 1/2-V Control)
43		1.3			7.0		Loop Integrator Capacitor
44		2.1			3.2		Control AMP Reference
Q0500E		13.0			13.0		A+ - CR0500 Drop
Q0501C		12.3			12.3		VQ0500E - B/E Drop
Q0501E		0.2			0.2		V pin 23 - B/E Drop
Q0503E		0			1.5		V pin 42 - B/E Drop (TX)
Q0503C		13.6			9.0		
Q0504B		13.6			12.9		A+ - B/E Drop (TX)

4.5.1.3.3 Localizing Problems

Failure locations often can be determined by externally measured symptoms. Basic symptoms are noted below with probable failure locations.

1. Low Power and High Current
 - Check for improper load conditions caused by high VSWR external to the radio.
 - Check output coax and mini UHF connector.
 - Check harmonic filter.
 - Check output impedance-matching circuitry from the final device to the harmonic filter.
2. Low Power and Low Current
 - If control voltage drive is equal to 8.0 V, then check per the above.
 - If control voltage drive is less than 8.0 V, then check the control circuitry.
3. Power Intermittently Low (or Zero) and Current Less than 1 A. When Power Drops
 - Check LLA stage.

4. Power Zero and Current Greater Than 5 A.
 - Check harmonic filter, antenna switch, and matching circuits beyond final stage.
5. Power Zero and Current Between 2 and 5 A.
 - Check driver and/or final stages.
6. Power Zero and Current Less Than 1 A.
 - Check LLA/driver circuitry.

4.5.1.3.4 Isolating Failures

Methods of analyzing individual stages of the power amplifiers are detailed below. Most of the stages are Class C and must be analyzed under relatively high RF power levels. Generators capable of such levels may not be available in all service shops, therefore the tests below are arranged in order of ascending power. This tends to allow the preceding stage to be the source of RF power for testing the next stage.

Testing Low-Level Amplifier (LLA) Circuitry

The required DC and RF conditions are defined in [Table 4-15 on page 4-40](#). Measure LLA voltages according to [Table 4-16](#).

If the above DC bias conditions are correct, check to see if the LLA is providing drive power to the driver Q3804. Do so by checking Q3804's collector current under normal drive conditions, as follows:

- Remove R3810 and L3806 (Be sure to reinstall after testing).
- Solder wires to the remaining pads.
- Place an ammeter in series with the collector of Q3804.
- Check for 0.1 to 0.5 A. depending on the control voltage.

NOTE: With no RF drive to the input of the PA, the collector current of Q3804 should be zero.

Table 4-16. LLA and Pre-Driver Typical Voltages

CONTROL VOLTAGE	RF DRIVE OFF		RF DRIVE ON	
	9.2 V	6.0 V	9.2 V	6.0 V
Q3801	—	—	—	—
Base	0.7	0.7	0.7	0.5
Collector	8.3	9.0	8.0	8.8
Q3802	—	—	—	—
Base	7.7	8.4	7.5	8.2
Collector	2.0	1.4	2.3	1.2
Emitter	8.3	9.0	8.0	8.8
Q3806	—	—	—	—
Base	5.1	4.1	5.1	4.1
Collector	7.7	8.4	7.5	8.2
Emitter	4.5	3.4	4.5	3.4
Q3804	—	—	—	—
Base	0.5	0.5	0.0	0.2
Collector	13.8	13.8	13.3	13.4

If the above DC bias conditions are correct, check to see if the LLA is providing drive power to the pre-driver, Q3804. Do so by checking Q3804's collector current under normal drive conditions, as follows:

- Remove R3810 and L3806 (Be sure to reinstall after testing).
- Solder wires to the remaining pads.
- Place an ammeter in series with the collector of Q3804. Check for 0.1 to 0.5 A. depending the control voltage.

NOTE: With no RF drive to the input of the PA, Q3804's collector current should be zero.

If Q3804 draws no current under normal conditions, then check for a shorted or open input cable, or for defective parts in the input network or matching circuitry between Q3801 and Q3804. If all the above check out OK, then replace Q3801.

Testing Pre-Driver Circuitry

The pre-driver is a typical Class C stage, except the base is biased with resistors R3809 and R3806. The necessary conditions for proper operation of this stage are input drive power, and bias conditions as shown in [Table 4-16 on page 4-43](#).

NOTE: If it is necessary to replace Q3804, use a hot-air blower to remove and replace the part. It is important that the replacement device's case be properly soldered to its heatsink. Do so by flowing a small bead of solder around the rim of the device while it is clamped in the hot-air soldering device. The base and collector leads must be hand-soldered on the bottom of the board.

Troubleshooting the Driver Stage

- Make sure A+ is at the collector.
- Check for shorts and/or opens in the matching circuitry. Also look for faulty components.
- Measure the DC resistance from base to emitter. It should be less than 1 ohm. If not, check L3810 for proper soldering and replace if faulty.
- Check the current drain of the driver. It should be around 0.5 to 2.5 A. for 50-Watt operation. If current drain is low, go to next step.
- Unsolder the base lead. Making sure the lead is not touching the PC board, check the base-emitter and base-collector junction diode drops. Normal voltage drop should be between 0.4 and 1.0 V. If either junction reads outside this range, replace the driver device.
- Unsolder either L3854, R3875, or L3851 to isolate the driver and final stages. Measure the collector emitter DC resistance. If the resistance is below 5k ohms, then replace the driver device.

Troubleshooting the Final Device

- Make sure A+ is at the final's collector; if not, check for shorts and/or opens.
- Check the matching circuitry for shorts and/or opens. Also, check for faulty components.
- Measure the resistance from base to emitter; it should be less than 1 ohm. If not, check for proper soldering on L3852 and L3853; replace faulty component (s).
- Current drain on the final device should be >6 A. for 50-Watt operation. If low current, go on to the next step.
- Remove L3853 from the board and check the base-emitter and base-collector junction diode drops. Normal voltage drop should be between 0.4 and 1.0 V. If either junction is outside the range, replace the final device.

- Unsolder either L3859, R3875, or L3851 to isolate the driver and final stages. Measure the collector emitter DC resistances. If the resistance is below 5k ohms, then replace the driver device.

NOTE: The position of capacitors C3853 and C3854 is critical to the performance of the circuit. If they are removed for any reason, they must be re-installed as close to the cap of the final device as possible. When replacing either the driver or final device, apply thermal compound on the heatsink surface. Torque the screws to the correct value; see the *ASTRO Digital Spectra and Digital Spectra Plus Mobile Radios Basic Service Manual* (6881076C20).

Testing the Antenna Switch and Harmonic Filter

Verify that most of this circuit is functioning properly by testing the receiver insertion loss as follows:

- Apply a low-level signal source at the antenna connector.
- Apply the conditions indicated in [Table 4-14 on page 4-39](#) for RX tests.
- If the difference between the input and output (insertion loss) is less than 1 dB, then the circuitry is functioning properly.

Additional antenna switch tests are:

- Check CR3920, CR3921, and CR3922 with an ohm meter for forward and reverse continuity.
- In the transmit mode, adjust the control voltage for 55 Watts at the antenna connector. Check for less than 10 mW at the end of the receive input cable. If power exceeds 10 mW, then check CR3922 and associated circuitry. Receiver sensitivity can degrade if power at this port exceeds 10 mW.
- Check for proper DC current through the PIN diodes; correct current is indicated if approximately 1.5 V is present at the junction of C3900 and L3900 during the transmit mode.

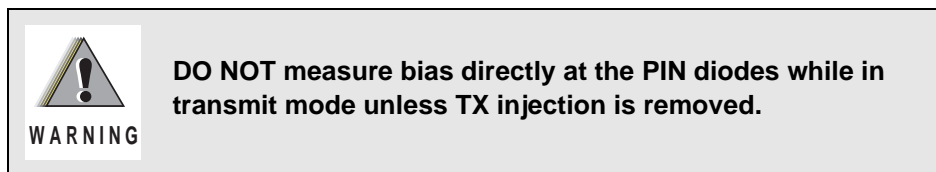

4.5.1.3.5 Power Control and Protection Circuitry

Localizing Problems to a Circuit

Power leveling and current limiting are set to values detailed in the *ASTRO Digital Spectra and Digital Spectra Plus Mobile Radios Basic Service Manual* (6881076C20). These values will vary from unit to unit, depending on the unique variations of each unit. If symptoms indicate that either of these circuits have failed, verify that the radio has been properly aligned before investigating the circuitry.

Temperature sense and control voltage limit are fixed by design and are not influenced by the alignment of the radio. If symptoms indicate that these circuits have failed, then troubleshoot the circuit.

The tests that follow are intended to provide a convenient means of verifying that a particular circuit is functioning properly. These tests will isolate the failure to a minimum number of components. Refer to the Theory of Operation and the schematic for information needed to identify the failed component(s).

Temperature Sense Circuit Test

Temporarily place a leaded 6.8k ohm resistor in parallel with RT3875. Key the transmitter and monitor the output power. The power meter should read approximately 1/2 the rated power (25 Watts).

Control-Voltage-Limit Circuitry Test

Disconnect the transmitter injection from the internal transceiver chassis. This will require removal of the power amplifier assembly. With all other connections in normal condition, key the transmitter and monitor the control voltage. If the voltage exceeds 9.0 V, troubleshoot the control voltage limit circuitry.

Current-Limiting Circuitry Test

When ready to adjust current limit, decrease the relative current limit value with the keyboard per instructions. After several decrements, the current limit should begin to reduce power. After this test, reset the current limit to its original value. If the circuitry does not perform as indicated, troubleshoot the current limit circuitry.

Power-Leveling Circuitry Test

With the radio connected for power measurements, vary the line voltage from 12.5 to 16 V. The power should not vary more than 12.5 to 16 V. The power should not vary more than 2 Watts. At a line voltage of 13.6 V, vary the frequency using the three test modes.

If power varies more than 2 Watts, measure the detected voltage on P0853, pin 9. If this voltage varies more than 0.2 V over line and frequency variations, the power control circuitry (most of which is located on the command board) may be malfunctioning. If the detected voltage varies less than 0.2 V, the problem is probably in diode CR3900, the harmonic filter, the antenna switch, or the output coax. Check continuity through the 12-pin connector P0853 on the PA board; check digital/analog circuitry, and check 5-V regulator operation. See [Table 4-15 on page 4-40](#) for typical values.

With the radio connected for power measurements and a disconnected TX injection coax, the detected voltage at P0853, pin 9, should measure approximately 1.3 V.

NOTE: If any part of the power leveling circuitry is replaced, perform the power set procedure. See the *ASTRO Digital Spectra and Digital Spectra Plus Mobile Radios Basic Service Manual* (6881076C20) for details.

4.5.2 UHF Band

4.5.2.1 High-Power Amplifier

This information will help you troubleshoot the Spectra radio. Use this information, along with the Theory of Operation, to diagnose and isolate the cause of failures. This section includes troubleshooting information that will help you test and check the circuits to localize and isolate problems.

Prior to troubleshooting, it is important to review the Theory of Operation, including specific precautions and troubleshooting methods. Because much of the radio's circuitry operates at UHF frequencies, measurements must be taken very carefully. Notes and cautions are added to the text to alert the reader to this need in areas of greatest sensitivity. However, the need for extreme care does exist in all measurements and tests at UHF frequencies.

4.5.2.1.1 General Troubleshooting and Repair Notes

Most of the common transmitter symptoms are not necessarily caused by failure of circuits on the PA board. Failure of command board or synthesizer circuits can disable the transmitter. The initial troubleshooting effort should be toward isolating the problem to one of these areas. If either the control voltage or keyed 9.4 V are zero, then the problem is likely to be in the control circuit or synthesizer. If those voltages are present, then the problem is more likely in the power amplifier circuit.

If, for diagnostic reasons, a chip component needs to be removed to facilitate testing, such as a series capacitor removed to allow for signal insertion, then the component(s) returned to the circuit should be new parts. The application of a soldering iron to many chip components will tend to cause leaching which could lead to failure.

If the harmonic filter is damaged and needs to be replaced, then removal and replacement requires the use of a hot-air source capable of reflowing the solder beneath the filter hybrid. When replacing it, add small amounts of fresh solder paste to the silver regions beneath the ceramic to assure adequate electrical ground contact. Save the original input and output connectors (J-straps); these are not included with the replacement kit. No tuning is required. The harmonic filter may be ordered separately, but if the PA kit is ordered a filter kit comes with the PA kit.

After a PA board is replaced, or if any power control circuitry components are replaced, readjust the power according to instructions in the *ASTRO Digital Spectra and Digital Spectra Plus Mobile Radios Basic Service Manual* (6881076C20).

NOTE: Due to high operating frequencies, you must use specified Motorola parts when component replacement is necessary. Substitute components may not work. It is also critical that you use great care when replacing parts. Excessive solder or flux, Longer than original leads on coax connectors, misorientation of parts, and other commonly benign imperfections, may cause the radio's performance to degrade.

Bench testing the high-power Spectra PA is most easily accomplished if a Spectra control head, control cable, and power cable are available on the test bench. This greatly simplifies the troubleshooting as several supply voltages are provided by the command board. Proper operation of the command board circuitry can be simultaneously verified.

Begin troubleshooting by connecting an RF power meter and appropriate power load to the antenna connector. Connect the control cable and the power cable. Make sure the ignition sense lead is also connected to the positive lead of the power supply. Note that a regulated DC power supply capable of at least 30 A. is necessary to power a high-power Spectra transmitter. Remove the radio bottom cover. Remove the PA shield by pulling straight up on the plastic handle. This must be done carefully, as the edge of the PA shield can damage components on the PA board if it is removed unevenly. Set the power supply to 13.4 V. The radio may now be turned on. All critical voltages may be measured at connector J1 from the top side of the PA board. A diagram of the connector pin-out as viewed from the top side of the PA board is shown in [Figure 4-7](#).

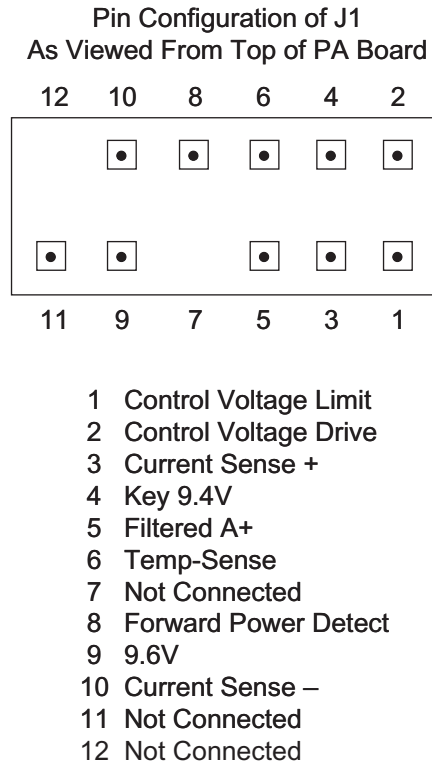

Figure 4-7. Connector Pin-Out—High-Power Amplifier

Table 4-17. Power Control DC Voltage Chart

LOCATION	RX MODE			TX MODE			COMMENTS
	LOW	TYP	HI	LOW	TYP	HI	
J1							
1		0		0	2.0	3.2	Control Voltage Limit
2		0		2.0	7.0	10.0	Drive Voltage
3	10.8	13.6	16.5	10.0	13.0	16.0	Current Sense +
4	0	0	0	9.2	9.4	9.8	Keyed 9.4
5	10.8	13.6	16.5	10.0	13.0	16.0	A+ to Command Board
6		0			1.2		Temp Sense (cutback begins at 3.3 V)
7	—	—	—	—	—	—	Key (no pin)
8		0		13.0	9.3	5.0	Forward Detect Voltage
9	10.8	13.6	16.5	10.0	13.0	16.0	A+ to Command Board
10	9.4	9.6	9.9	9.4	9.6	9.9	9.6-V Supply from Command Board
11	10.8	13.6	16.5	9.8	12.8	15.8	Current Sense - (voltage delta 150 mV)
12	—	—	—	—	—	—	Key (no pin or wire)
U0500							
1	0	0	0	0	0	0	Ground
2		0			3.2		Control AMP Input
3	0	0	0	0	0	0	Control AMP Input (not used)
4		0		0	2	3.2	Control Voltage Limit (cutback at 3.3 V)
5		9			0		N.C.
6	1.5	3.0	4.5	1.5	3.0	4.5	Power Set from D-A (max power at 1.5 V)
7		0		1.5	3.0	4.5	Power Set Buffer Out
8		0		1.3	3.5	6.0	Coupler Buffer Out
9		0		1.3	3.5	6.0	Forward Detect Volt
10		0			0		Reflected Power Detect (not used)
11		0		1.3	3.5	6.0	Same as pin 8 (not used)
12		0		0	1.2	6.0	Thermister Buffer out (increases as PA gets hot)
13		0		0	1.2	6.0	Thermister Buffer in
14		5.0			5.0		5-V Sense Input (follows pin 20 ±0.1 V)
15	4.9	5.0	5.7	4.9	5.0	5.7	5-V Current Limit (limits at 5.7 V)

Table 4-17. Power Control DC Voltage Chart (Continued)

LOCATION	RX MODE			TX MODE			COMMENTS
	LOW	TYP	HI	LOW	TYP	HI	
J1							
16	5.0	5.7	6.4	5.0	5.7	6.4	5-V Series Pass Drive (6.4 at max current)
17	9.5	9.6	9.9	9.5	9.6	9.9	9.6-V Sense Input
18		7			7		5-V Reg. Compensation Capacitor
19		5.7			5.7		N.C.
20	4.9	5.0	5.1	4.9	5.0	5.1	5-V Reference Input (UNSW5-V)
21		1.2			1.2		9.6-V Reg. Compensation Capacitor
22		0			0		N.C.
23		0.9	9.6		1.2	9.6	9.6-V Series Pass Drive
24		2.9			3.3		Regulator Enable/Compensation
25	v	—	—	—	—	—	9.6-V Programming (N.C.)
26		0			0		N.C.
27		13.6			13.6		N.C.
28	—	—	—	—	—	—	9.6-V Programming (N.C.)
29	—	—	—	—	—	—	9.6-V Programming (N.C.)
30	—	—	—	—	—	—	9.6-V Programming (N.C.)
31	0	0	0	0	0	0	Ground
32	10.8	13.6	16.5	10.0	13.0	16.0	Decoupled A+
33	4.0	5.0			0	0.2	$\overline{\text{TX PA Enable}}$ (from U520-25)
34		0			1.3		Control AMP one-shot
35		0			0		$\overline{\text{Lock}}$ (5-V of Synth Out of Lock)
36		0			0.8		Control AMP one-shot
37	10.8	13.6	16.3	10.0	13.0	16.0	A+ (Current Sense +)
38	10.8	13.6	16.3	10.0	13.0	16.0	Current Sense - Voltage Delta 150 mV
39		0		9.2	9.4	9.8	Keyed 9.4-V in
40	1.5	3.0	4.5	1.5	3.0	4.5	Current Limit D-A (max current at 4.5 V)
41	0	0	0	0	0	0	Ground
42		0			2.2	9.6	Control AMP Output (Approx 1/2-V Control)
43		1.3			7.0		Loop Integrator Capacitor

Table 4-17. Power Control DC Voltage Chart (Continued)

LOCATION	RX MODE			TX MODE			COMMENTS
	LOW	TYP	HI	LOW	TYP	HI	
J1							
44		2.1			3.2		Control AMP Reference
Q0500E		13.0			13.0		A+ - CR0500 Drop
Q0501C		12.3			12.3		VQ0500E - B/E Drop
Q0501E		0.2			0.2		V pin 23 - B/E Drop
Q0503E		0			1.5		V pin 42 - B/E Drop (TX)
Q0503C		13.6			9.0		
Q0504B		13.6			12.9		A+ - B/E Drop (TX)

Key the transmitter. The RF power meter should read at least 100 Watts if it is calibrated. Range 3 UHF radios will have power set to 78 Watts at modes above 470 MHz. R4 UHF radios will be set to 78 Watts on all modes. If power is low, the power set must be checked first before suspecting a defective PA or command board. This may be checked using a PC and RSS software. Alternatively, front panel programming may be used. Please refer to the *ASTRO Digital Spectra and Digital Spectra Plus Mobile Radios Basic Service Manual* (6881076C20) for programming instructions.

If correct power output can not be obtained by following the power set procedure outlined in the *ASTRO Digital Spectra and Digital Spectra Plus Mobile Radios Basic Service Manual* (6881076C20), it is possible that current limit may be improperly set. This can not be adjusted using front panel programming. A PC with RSS must be used. A simple way to check for current limit engagement is to temporarily short out the current sense resistor R5875 with a piece of 12- or 14-gauge wire. If full power is restored, then RSS must be used to properly set current limit.

If it is verified that both power set and current limit are not related to the power problem, then the synthesizer output must be checked. A milliwatt meter connected to the TX injection cable should indicate at least 30 mW of injection power during key-up. If this is not the case, refer to the RF Board and VCO troubleshooting procedures in this chapter.

If the command board and synthesizer are functioning properly, the PA must be defective. Details on troubleshooting each circuit of the PA follow.

4.5.2.1.2 PA Functional Testing

NOTE: When setting or measuring RF power at UHF, follow these guidelines to avoid measurement errors due to cable losses or non-50-ohm connector VSWR:

- All coaxial cables should be low loss and as short as possible.
- Attenuators and 50-ohm loads should have at least 25 dB return loss.
- Mini UHF to 'N' adapter, P/N 58803671321, should be used at the antenna connector. All other connectors should be 'N' type. No other adapters, barrel connectors, etc. should be used.

Maximum input level to the PA is 50 mW. Too much input power could result in damage to the LLA stage.

Methods of analyzing individual stages of the power amplifiers are detailed below. Most of the stages are Class-C and must be analyzed under relatively high RF power levels. The following information should help in isolation and repair of the majority of transmitter failures.

Testing Low-Level Amplifier (LLA) Circuitry

Proper operation of the LLA can be checked by monitoring the voltage across resistor R5805. The voltage should measure in the range of 0.4 to 1.2 V, depending on the value of control voltage. A 0.4-V reading corresponds to a low control voltage (4 to 5 V) and a 1.2-V reading corresponds to a high control voltage (up to control voltage limit).

Measure LLA voltages according to [Table 4-18](#). If the DC bias conditions are correct, check to see if the LLA is providing drive power to Q5803. Do so by checking Q5803 collector current under normal drive conditions, as follows:

- Remove R5810 and L5806 (Be sure to reinstall after testing).
- Solder wires to the remaining pads.
- Place an ammeter in series with Q5803 collector.
- Check for 0.2 to 0.5 A. (depending on control voltage).

NOTE: With no RF drive to the input of the PA, Q5803 collector current should be zero.

Table 4-18. LLA and 2nd Stage Typical Voltages

CONTROL VOLTAGE	RF DRIVE OFF		RF DRIVE ON	
	10.0 V	6.0 V	10.0 V	6.0 V
Q5801	—	—	—	—
Base	0.7	0.7	0.7	0.3
Collector	8.1	9.1	8.0	8.8
Q5800	—	—	—	—
Base	7.6	8.5	7.4	8.3
Collector	2.3	1.4	2.8	1.1
Emitter	8.1	9.1	8.0	8.8
Q5806	—	—	—	—
Base	6.4	3.8	6.4	3.9
Collector	7.6	8.5	7.4	8.3
Emitter	5.7	3.2	5.7	3.2
Q5803	—	—	—	—
Base	0.6	0.6	0.0	0.3
Collector	9.6	9.6	9.5	9.5

NOTE: The LLA voltages change with different control voltages. An example of LLA voltages with control voltage equal to 10.0 V and 6 V is shown.

If Q5803 draws no current under normal conditions, then check for short or open input cable, or for defective parts in the transmit injection filter or matching circuitry between Q5801 and Q5803.

Testing Second Stage Circuitry Q5803

The second stage is a typical class-C stage, except the base is biased with resistors R5809 and R5806. The necessary conditions for proper operation of this stage are input drive power, and bias conditions as shown in [Table 4-18](#).

NOTE: If it is necessary to replace Q5803, use a hot-air blower to remove and replace the part. It is important that the replacement device's case be properly soldered to its heatsink. Do so by flowing a small bead of solder around the rim of the device while it is clamped in the hot-air soldering device. The base and collector leads must be hand-soldered on the bottom side of the board.

Troubleshooting the Third Stage Q5850

- Make sure A+ is at the collector.
- Check for shorts and/or opens in the matching circuitry. Also look for faulty components (cracked parts or parts not properly soldered).
- Measure the DC resistance from base to emitter. It should be less than 1-ohm. If not, check L5851 and L5852 for proper soldering, and replace if faulty.
- Check the current drain of Q5850. Remove L5854 and R5850 and solder wires to the pads. With an ammeter connected to these wires, check the collector current drain during transmit. It should be around 1.5 to 2.0 A. If current drain is low, go to next step.
- Remove L5851 from the board and check the base-emitter and base-collector junction diode voltages using the diode check function of a multimeter. Normal voltage drop should be near 0.6 V. If either junction is open or short circuited replace the device.

Troubleshooting the Driver Stage Q5851

- Make sure A+ is at the driver's collector. Check for shorts and or opens.
- Check the matching circuitry for shorts and/or opens. Also, check for faulty components. (Cracked parts or parts not properly soldered.)
- Measure the resistance from base to emitter; it should be less than 1 ohm. If not, check for proper soldering on L5855 and L5857. Replace faulty component(s).
- Current drain for this stage should be close to 5 A. If low current, go to the next step.
- Remove L5857 from the board and check the base-emitter and base-collector junction diode drops. Normal voltage drops should be near 0.6 V. If either junction is open or shorted, replace the device.

NOTE: The position of capacitors C5861, C5862, C5863 and C5864 is critical to the performance of the circuit. If they are removed for any reason, they must be re-installed in the exact same physical location from which they were removed.

Analysis of the Final Amplifier Stage (Q5875 and Q5876)

Extreme care must be taken when troubleshooting the final amplifier due to the high RF currents and voltages present.

A visual inspection of the matching networks should be done first. Check for defective solder joints or burned components. Good soldering of the transistor device leads is essential. Make sure A+ voltage is reaching the collector of each final device.

Check the base-emitter and base-collector junctions of the final devices by removing L5877, L5876, and R5878. Using the diode check function of a multimeter, the junctions should have a forward voltage drop close to 0.6 V. Replace a final device if it has an open or shorted junction.

Capacitors C5885, C5886, C5887, and C5888 are placed on the bottom side of the PA board underneath the leads of the final devices. Extreme care should be used when replacing these parts. Exact positioning is critical. Inspect for solder shorts on these capacitors before installing the PA board in the radio chassis.

Installation of the PA board into the radio chassis must be done carefully. The PC board screws use a T-15 Torx bit and should be torqued to 6 to 8 inch-pounds. The device screws use a T-8 Torx bit and should be torqued to 6 to 8 inch-pounds. Always apply thermal compound to the area under the device flanges before installing the PA board.

Current drain of the final amplifier may be checked by measuring the voltage across R5875 during transmit. A voltage drop of 0.10 to 0.15 V indicates the finals are drawing 10 to 15 A., which is within the acceptable range.

Testing the Antenna Switch and Harmonic Filter

Use care when replacing the harmonic filter. Removal of the filter is best accomplished by heating the filter/PC board assembly with a heat gun or heat blower until the solder joint reflows.

Verify that the receive path of the antenna switch and the harmonic filter are functioning by testing the receiver insertion loss as follows:

- Apply a low-level signal source at the antenna connector.
- Verify the conditions indicated in [Table 4-17 on page 4-49](#) for RX tests.
- Measure the power at the receive coax.
- If the difference between the input and output (insertion loss) is less than 1 dB, then the circuitry is functioning properly. Additional antenna switch tests are:
 - Check CR5900, CR5902, CR5904, and CR5905 using the diode-check function of a multimeter. Note that CR5904 and CR5905 are on the bottom side of the board. These two diodes affect the receive path only and are unrelated to transmitter problems.
 - Check for proper DC current through the PIN diodes; correct current is indicated if approximately 1.5 V is present at the junction of R5900 and L5900 during transmit.

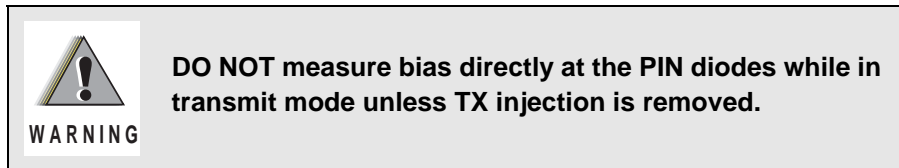

4.5.2.1.3 Power Control and Protection Circuitry

Localizing Problems to a Circuit

Power leveling and current limiting are set to values detailed in the *ASTRO Digital Spectra and Digital Spectra Plus Mobile Radios Basic Service Manual* (6881076C20). These values will vary from unit to unit, depending on the unique variations of each unit. If symptoms indicate that either of these circuits have failed, verify that the radio has been properly aligned before investigating the circuitry.

Temperature sense and control voltage limit are fixed by design and are not influenced by the alignment of the radio. If symptoms indicate that these circuits have failed, then troubleshoot the circuit.

The tests that follow are intended to provide a convenient means of verifying that a particular circuit is functioning properly. These tests will isolate the failure to a minimum number of components. Refer to the Theory of Operation and the schematic for information needed to identify the failed component(s).

Temperature Sense Circuit Test

Temporarily install a 2.2k ohm resistor in parallel with RT5875. Key the transmitter and monitor the output power. The power meter should read approximately one-half the rated power.

Control-Voltage-Limit Circuitry Test

Disconnect J5901 (transmitter injection) from the PA input. With all other connections in normal condition, key the transmitter and monitor the control voltage at J1 pin 2. If the voltage exceeds 10.0 V, troubleshoot the control voltage limit circuitry.

Current-Limiting Circuitry Test

When ready to adjust current limit, decrease the relative current limit value with the keyboard per instructions. After several decrements, the current limit should begin to reduce power in 0.5 to 1.0 Watt increments. After this test, reset the current limit to its original value. If the circuitry does not perform as indicated, troubleshoot the current limit circuitry.

Directional Coupler and Power-Leveling Test

The directional coupler combined with the RPCIC form a closed-loop power leveling circuit. This circuit keeps forward power essentially constant under variations of line voltage, frequency, and VSWR.

The directional coupler samples a small amount of forward power during transmit. This power is rectified by a detector diode CR5906. This rectified DC voltage is fed back to the RPCIC where it is compared to a reference voltage. An error voltage is generated which is ultimately translated into the control voltage via RPCIC circuitry and amplifiers Q503 and Q504 on the command board. Control voltage is routed to the LLA stage, thereby completing the feedback loop. In operation, the control loop tends to maintain the forward detected voltage constant versus frequency and line voltage variations. Proper operation can be observed by monitoring the forward detected voltage while varying the supply voltage from 13.4 to 16.1 V. Forward-detected voltage should not change more than a few hundredths of a volt. Note that the forward power may not necessarily be level if one of the other protection circuits such as temp-sense or current limit are engaged.

PA Voltage Protection Circuit

Some versions of the PA board may include a voltage protection circuit. This circuit is intended to prevent premature failure of a transmitter operated in extreme conditions. An example of an extreme condition would be operation at above normal battery voltages (greater than 15 V) combined with high temperatures (greater than 500°C or 122°F).

The circuit monitors the A+ voltage from the battery, and it is activated if the A+ voltage exceeds approximately 15 V. R5825 and R5823 form a voltage divider connected to A+. The divided A+ voltage is connected to the base of Q5805. The emitter of Q5805 is connected to Zener diode Z1. This 5-V Zener diode, combined with the voltage divider action of R5825 and R5823, sets the voltage "trip point" at which Q5805 turns on (A+ near 15 V). When Q5805 turns on, this provides a path for current to flow through the base-emitter junction of Q5802. Q5802 then acts as a switch to connect the K9.4 voltage supply to R5826 and the directional coupler circuit composed of C5924, R5916, R5905, and R5904. A fixed DC bias voltage is applied to the forward power detector.

This fixed DC bias voltage is summed with the rectified RF signal that is coupled from the output of the transmitter. Since the PA power control requires that the detected voltage is a constant value, the output power of the power amplifier must be reduced by an amount proportional to the applied DC bias. The values of R5916, R5905, and R5904 are chosen such that power is cut in half. The reduced output power decreases the current drain of the transmitter, and therefore reduces the internal temperature of the amplifier devices which increases their lifetime. The circuit disengages and full rated power is restored if the over-voltage condition is corrected.

Low-Voltage Current Drain Cutback

An additional circuit associated with the over-voltage protection circuit is the low-voltage current drain circuit. This circuit acts to reduce the transmitter current drain under conditions of low supply voltage. This action extends the available transmit time when, for example, the transmitter in a vehicular installation must be used when the engine is not running. Operation of this circuit is similar to the over-voltage circuit. R5819 and R5820 form a voltage divider which is connected to the base of transistor Q5804. If the A+ voltage drops below approximately 12 V, Q5804 will begin to conduct. This turns on Q5802, which supplies a DC bias voltage to the forward power detector as explained in the Theory of Operation for the over-voltage protection circuit. The transmitter output power is reduced by the power control, which results in reduced current drain and extended battery life.

NOTE: If any part of the power leveling circuitry is replaced, perform the power set procedure. See the *ASTRO Digital Spectra and Digital Spectra Plus Mobile Radios Basic Service Manual* (6881076C20) for details.

Miscellaneous Circuits and Notes

Diode CR5875 acts as a reverse-protect diode. This diode also protects from over-voltage conditions, as it has a Zener breakdown voltage of approximately 28 V. When replacing this diode, care must be taken to place the diode with the cathode marking ring down (towards the PC board).

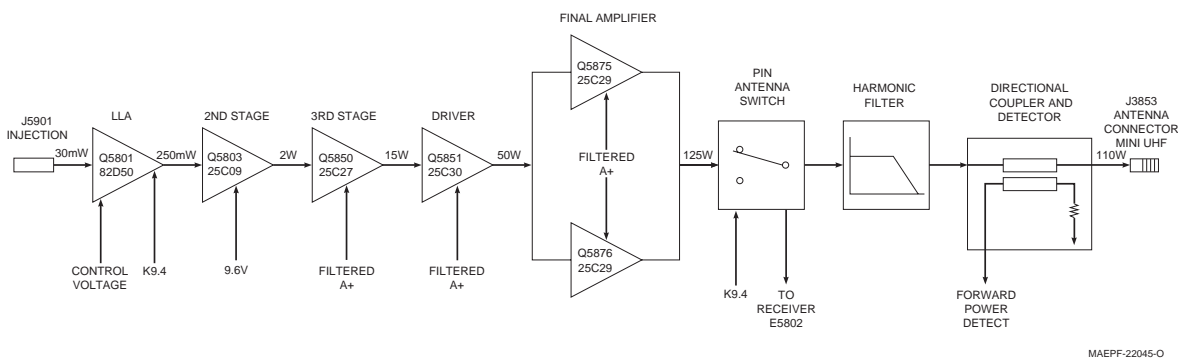

Figure 4-8. Block Diagram for Spectra High-Power Power Amplifier

4.5.2.2 40 Watt Power Amplifiers

This information will help you troubleshoot the Spectra radio. Use this information, along with the Theory of Operation, to diagnose and isolate the cause of failures. The principle tools needed to troubleshoot a circuit to the component level are the schematic and the Theory of Operation.

In addition to the schematic and theory, this section includes troubleshooting information that will help you test and check the circuits to localize and isolate problems.

Prior to troubleshooting, it is important to review the Theory of Operation, including specific precautions and troubleshooting methods. Because much of the radio's circuitry operates at UHF frequencies, measurements must be taken very carefully. Notes and cautions are added to the text to alert the reader to this need in areas of greatest sensitivity. However, the need for extreme care does exist in all measurements and tests at UHF frequencies.

4.5.2.2.1 General Troubleshooting and Repair Notes

Most of the common transmitter symptoms are caused by either failure of the power amplifier or a failure in the control circuitry. The initial troubleshooting effort should be toward isolating the problem to one of those two areas. If either the control voltage or keyed 9.4 V are zero, then the problem is likely to be in the control circuit. If those voltages are present, then the problem is more likely in the power amplifier circuit.

If, for diagnostic reasons, a chip component needs to be removed to facilitate testing, such as a series capacitor removed to allow for signal insertion, then the component(s) returned to the circuit should be new parts. The application of a soldering iron to many chip components will tend to cause leaching which could lead to failure.

If the harmonic filter is damaged and needs to be replaced, then removal and replacement requires the use of a hot-air source capable of reflowing the solder beneath the filter hybrid. When replacing it, add small amounts of fresh solder paste to the silver regions beneath the ceramic to assure adequate electrical ground contact. Save the original input and output connectors (J-straps); these are not included with the replacement kit. No tuning is required. The harmonic filter may be ordered separately, but if the PA kit is ordered, a filter kit comes with the PA kit.

After a PA board is replaced, or if any power control circuitry components are replaced, readjust the power according to instructions in the *ASTRO Digital Spectra and Digital Spectra Plus Mobile Radios Basic Service Manual* (6881076C20).

NOTE: Due to high operating frequencies, you must use specified Motorola parts when component replacement is necessary. Substitute components may not work. It is also critical that you use great care when replacing parts. Excessive solder or flux, longer than original leads on coax connectors, misorientation of parts, and other commonly benign imperfections may cause the radio's performance to degrade.

4.5.2.2.2 PA Functional Testing

Test the PA assembly for proper operation as follows:

1. Disassemble the PA assembly from the radio, leaving the power cable connected to the rear connector. Replace the PA shield and cover. Disconnect the coax connectors and the ribbon cable. Connect a power meter to the antenna port using minimum cable length.
 - When setting or measuring RF power at UHF, follow these guidelines to avoid measurement errors due to cable losses or non-50-ohm connector VSWR:
 - All cables should be very short and have Teflon dielectric.
 - Attenuators and 50-ohm loads should have at least 25 dB return loss.
 - Mini UHF to 'N' adapter, P/N 5880367B21, should be used at the antenna connector. All other connectors should be 'N' type. No other adapters, barrel connectors, etc. should be used.
 - Maximum input level to the PA is 50 mW. Too much input power could result in damage to the LLA stage.
2. Apply the input power and DC voltages indicated in [Table 4-19 on page 4-58](#) to the power amplifier assembly. To make the DC connections, use small spring--clips or make a test adapter similar to that shown in [Figure 4-9 on page 4-58](#).
3. Apply the required input power via an adapter cable. For this application, non N-type connectors are acceptable.
4. With the applied control voltage initially at 0 V, slowly increase the voltage until power out equals 46 Watts. Power should rise smoothly with control voltage once the turn-on threshold is reached. Control voltage should not exceed 10.0 V.
5. If 10.0 V does not produce 46 Watts, then a failure exists in the power amplifier circuit.
6. Refer to the voltage chart ([Table 4-20 on page 4-59](#)). Measure the indicated voltages. If they are not within the limits shown in the chart, then a failure exists in the PA assembly.
7. If the voltages in the chart are correct, verify that the injection is at least 30 mW. (See the VCO troubleshooting section.)

8. If no failure is located from the previous checks, troubleshoot the power control circuitry.

Table 4-19. DC Voltages and Input Power Chart

Test	Keyed 9.4 V	9.6 V	CONTROL VOLTAGE DRIVE	POWER IN (mW)	A+ (V)
Transmit	9.4	9.6	See note ^a	30	13.0
Receive	0	9.6	0	0	13.0

a. Set initially to zero. Increase value until power equals 46 Watts or 10.0 V maximum. Do NOT exceed 10.0 V.

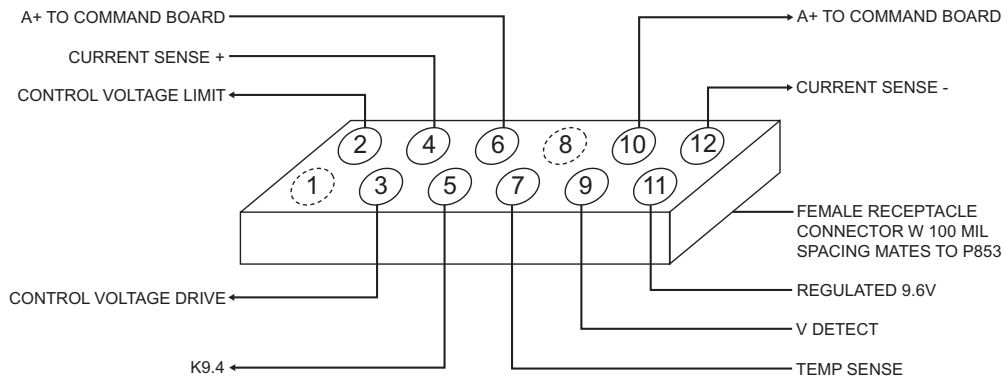

Figure 4-9. PA Test Adapter, 40 Watt Power Amplifier

Table 4-20. Power Control DC Voltage Chart

LOCATION	RX MODE			TX MODE			COMMENTS
	LOW	TYP	HI	LOW	TYP	HI	
P0853							
1	—	—	—	—	—	—	Key (no pin or wire)
2		0		0	2.0	3.2	Control Voltage Limit
3		0		2.0	7.0	10.0	Drive Voltage
4	10.8	13.6	16.5	10.0	13.0	16.0	Current Sense +
5	0	0	0	9.2	9.4	9.8	Keyed 9.4
6	10.8	13.6	16.5	10.0	13.0	16.0	A+ to Command Board
7		0			1.2		Temp Sense (cutback begins at 3.3 V)
8	—	—	—	—	—	—	Key (no pin)
9		0		13.0	9.3	5.0	Forward Detect Voltage
10	10.8	13.8	16.6	10.4	13.4	16.2	A+ to Command Board
11	9.4	9.6	9.9	9.4	9.6	9.9	9.6-V Supply from Command Board
12	10.8	13.6	16.5	9.8	12.8	15.8	Current Sense - (voltage delta 150 mV)
U0500							
1	0	0	0	0	0	0	Ground
2		0			3.2		Control AMP Input
3	0	0	0	0	0	0	Control AMP Input (not used)
4		0		0	2	3.2	Control Voltage Limit (cutback at 3.3 V)
5		0			0		N.C.
6	1.5	3.0	4.5	1.5	3.0	4.5	Power Set from D-A (max power at 1.5 V)
7		0		1.5	3.0	4.5	Power Set Buffer Out
8		0		1.3	3.5	6.0	Coupler Buffer Out
9		0		1.3	3.5	6.0	Forward Detect Voltage
10		0			0		Reflected Power Detect (not used)
11		0		1.3	3.5	6.0	Same as pin 8 (not used)
12		0		0	1.2	6.0	Thermister Buffer out (increases as PA gets hot)
13		0		0	1.2	6.0	Thermister Buffer in
14		5.0			5.0		5-V Sense Input (follows pin 20 ±0.1 V)

Table 4-20. Power Control DC Voltage Chart (Continued)

LOCATION	RX MODE			TX MODE			COMMENTS
	LOW	TYP	HI	LOW	TYP	HI	
15	4.9	5.0	5.7	4.9	5.0	5.7	5-V Current Limit (limits at 5.7 V)
16	5.0	5.7	6.4	5.0	5.7	6.4	5-V Series Pass Drive (6.4 at max current)
17	9.5	9.6	9.9	9.5	9.6	9.9	9.6-V Sense Input
18		7			7		5-V Reg. Compensation Capacitor
19		5.7			5.7		N.C.
20	4.9	5.0	5.1	4.9	5.0	5.1	5-V Reference Input (UNSW5-V)
21		1.2			1.2		9.6-V Reg. Compensation Capacitor
22		0			0		N.C.
23		0.9	9.6		1.2	9.6	9.6-V Series Pass Drive
24		2.9			3.3		Regulator Enable/Compensation
25	—	—	—	—	—	—	9.6-V Programming (N.C.)
26		0			0		N.C.
27		13.6			13.6		N.C.
28	—	—	—	—	—	—	9.6-V Programming (N.C.)
29	—	—	—	—	—	—	9.6-V Programming (N.C.)
30	—	—	—	—	—	—	9.6-V Programming (N.C.)
31	0	0	0	0	0	0	Ground
32	10.8	13.6	16.5	10.0	13.0	16.0	Decoupled A+
33	4.0	5.0			0	0.2	TX PA Enable (from U520-25)
34		0			1.3		Control AMP one-shot
35		0			0		Lock (5-V of Synth Out of Lock)
36		0			0.8		Control AMP one-shot
37	10.8	13.6	16.3	10.0	13.0	16.0	A+ (Current Sense +)
38	10.8	13.6	16.3	10.0	13.0	16.0	Current Sense - Voltage Delta 150 mV (30 Watt only)
39		0		9.2	9.4	9.8	Keyed 9.4-V in
40	1.5	3.0	4.5	1.5	3.0	4.5	Current Limit D-A (max current at 4.5 V)
41	0	0	0	0	0	0	Ground
42		0			2.2	9.6	Control AMP Output (Approx 1/2-V Control)

Table 4-20. Power Control DC Voltage Chart (Continued)

LOCATION	RX MODE			TX MODE			COMMENTS
	LOW	TYP	HI	LOW	TYP	HI	
43		1.3			7.0		Loop Integrator Capacitor
44		2.1			3.2		Control AMP Reference
Q0500E		13.0			13.0		A+ - CR0500 Drop
Q0501C		12.3			12.3		VQ0500E - B/E Drop
Q0501E		0.2			0.2		V pin 23 - B/E Drop
Q0503E		0			1.5		V pin 42 - B/E Drop (TX)
Q0503C		13.6			9.0		
Q0504B		13.6			12.9		A+ - B/E Drop (TX)

NOTE: For antenna switch transmit bias conditions, RF drive must be removed from PA.

Table 4-21. Antenna Switch DC Voltage Chart

LOCATION		TYPICAL RX	TYPICAL TX NO PRE- DRIVE	COMMENTS
CR5920	ANODE	0	1.6	
	CATHODE	0	0.8	
CR5921	ANODE	0	0.8	
	CATHODE	—	—	
CR5922	ANODE	0	<0.8	
	CATHODE	—	—	

4.5.2.2.3 Localizing Problems

Failure locations often can be determined by externally measured symptoms. Basic symptoms are noted below with probable failure locations.

1. Low Power and High Current
 - Check for improper load conditions caused by high VSWR external to the radio.
 - Check output coax and mini-UHF connector.
 - Check harmonic filter and J-straps for opens and/or shorts.
 - Check output impedance-matching circuitry from the final device to the harmonic filter.
2. Low Power and Low Current
 - If control voltage is equal to 10.0 V, then check per the above.
 - If control voltage is less than 10.0 V, then check the control circuitry.

3. Power Intermittently Low (or Zero) and Current Less than 1 A. When Power Drops
 - Check LLA stage.
4. Power Zero and Current Greater Than 2 A.
 - Check harmonic filter, antenna switch, matching circuits between driver and final stages, and matching circuits beyond final stage.
5. Power Zero and Current Less Than 1 A.
 - Check LLA/pre-driver circuitry.

4.5.2.2.4 Isolating Failures

Methods of analyzing individual stages of the power amplifiers are detailed below. Most of the stages are Class C and must be analyzed under relatively high RF power levels. Generators capable of such levels may not be available in all service shops, therefore the tests below are arranged in order of ascending power. This tends to allow the preceding stage to be the source of RF power for testing the next stage.

1. Testing Low-Level Amplifier (LLA) Circuitry

The required DC and RF conditions are defined in [Table 4-19 on page 4-58](#). Measure LLA voltages according to [Table 4-22](#).

If the above DC bias conditions are correct, check to see if the LLA is providing drive power to the pre-driver, Q5803. Do so by checking Q5803 collector current under normal drive conditions, as follows:

- Remove R5810 and L5806 (Be sure to reinstall after testing.)
- Solder wires to the remaining pads.
- Place an ammeter in series with Q5803 collector.
- Check for 0.2 to 0.5 A. (depending on control voltage).

NOTE: With no RFdrive to the input of the PA, Q5803 collector current should be zero.

Table 4-22. LLA and Pre-Driver Typical Voltages

CONTROL VOLTAGE	RF DRIVE OFF		RF DRIVE ON	
	10.0 V	6.0 V	10.0 V	6.0 V
Q5801	—	—	—	—
Base	0.7	0.7	0.7	0.3
Collector	8.1	9.1	8.0	8.8
Q5800	—	—	—	—
Base	7.6	8.5	7.4	8.3
Collector	2.3	1.4	2.8	1.1
Emitter	8.1	9.1	8.0	8.8
Q5806	—	—	—	—
Base	6.4	3.8	6.4	3.9
Collector	7.6	8.5	7.4	8.3
Emitter	5.7	3.2	5.7	3.2
Q5803	—	—	—	—
Base	0.6	0.6	0.0	0.3
Collector	9.6	9.6	9.5	9.5

NOTE: The LLA voltages change with different control voltages. An example of LLA voltages with control voltage equal to 10.0 V and 6 V is shown.

If Q5803 draws no current under normal conditions, then check for short or open input cable, or for defective parts in the transmit injection filter or matching circuitry between Q5801 and Q5803. If all of the above check out OK, then replace Q5803.

2. Testing Pre-Driver Circuitry.

The pre-driver is a typical class-C stage, except the base is biased with resistors R5809 and R5806. The necessary conditions for proper operation of this stage are input drive power, and bias conditions as shown in [Table 4-22 on page 4-62](#), above.

NOTE: If it is necessary to replace Q5803, use a hot-air blower to remove and replace the part. It is important that the replacement device's case be properly soldered to its heatsink. Do so by flowing a small bead of solder around the rim of the device while it is clamped in the hot-air soldering device. The base and collector leads must be hand-soldered on the bottom side of the board.

3. Troubleshooting the Driver Stage

- Make sure A+ is at the collector.
- Check for shorts and/or opens in the matching circuitry. Also look for faulty components. (Cracked parts or parts not properly soldered).
- Measure the DC resistance from base to emitter. It should be less than 1-ohm. If not, check L5851 and L5852 for proper soldering, and replace if faulty.
- Check the current drain of the driver. It should be around 1.5 to 2.0 A. for 40-Watt operation. If current drain is low, go to next step.
- Remove L5851 from the board and check the base-emitter and base-collector junction diode drops. Normal voltage drop should be between 0.4 and 1.0 V. If either junction reads outside this range, replace the driver device.

4. Troubleshooting the Final Device

- Make sure A+ is at the final's collector; if not, check for shorts and/or opens. If A+ is shorted, check C5877 and C5878 first for shorts, by lifting L5878 and measuring the resistance from collector to ground.
- Check the matching circuitry for shorts and/or opens. Also, check for faulty components. (Cracked parts or parts not properly soldered.)
- Measure the resistance from base to emitter; it should be less than 1 ohm. If not, check for proper soldering on L5875, L5876, and L5883; replace faulty component(s).
- Current drain on the final device should be >5 A. for 40-Watt operation. If low current, go on to the next step.
- Remove L5875 from the board and check the base-emitter and base-collector junction diode drops. Normal voltage drop should be between 0.4 and 1.0 V. If either junction is outside this range, replace the final device.

NOTE: The position of capacitors C5875, C5876, C5877, and C5878 is critical to the performance of the circuit. If they are removed for any reason, they must be re-installed as close to the cap of the final device as possible.

When replacing either the driver or final device, apply thermal compound on the heatsink surface. Torque the screws to the correct value; see the *ASTRO Digital Spectra and Digital Spectra Plus Mobile Radios Basic Service Manual* (6881076C20).

5. Testing the Antenna Switch and Harmonic Filter

Verify that most of this circuit is functioning properly by testing the receiver insertion loss as follows:

- Apply a low-level signal source at the antenna connector.
- Apply the conditions indicated in [Table 4-19 on page 4-58](#) for RX tests.
- Measure the power at the receive coax.
- If the difference between the input and output (insertion loss) is less than 1 dB, then the circuitry is functioning properly.

Additional antenna switch tests are:

- Check CR5920, CR5921, and CR5922 with an ohmmeter for forward and reverse continuity.
- In the transmit mode, adjust control voltage for 44 Watts at the antenna connector. Check for less than 10 mW at the end of the receive input cable. If power exceeds 10 mW, then check CR5922 and associated circuitry. Receiver sensitivity can degrade if power at this port exceeds 10 mW.
- Check for proper DC current through the PIN diodes; correct current is indicated if approximately 1.5 V is present at the junction of C5920 and L5920 during transmit mode.

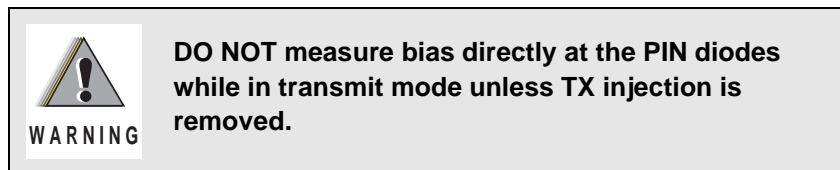

4.5.2.2.5 Power Control and Protection Circuitry

1. Localizing Problems to a Circuit

Power leveling and current limiting are set to values detailed in the *ASTRO Digital Spectra and Digital Spectra Plus Mobile Radios Basic Service Manual (6881076C20)*. These values will vary from unit to unit, depending on the unique variations of each unit. If symptoms indicate that either of these circuits have failed, verify that the radio has been properly aligned before investigating the circuitry.

Temperature sense and control voltage limit are fixed by design and are not influenced by the alignment of the radio. If symptoms indicate that these circuits have failed, then troubleshoot the circuit.

The tests that follow are intended to provide a convenient means of verifying that a particular circuit is functioning properly. These tests will isolate the failure to a minimum number of components. Refer to the Theory of Operation and the schematic for information needed to identify the failed component(s).

2. Temperature Sense Circuit Test

Temporarily install a 6.8k ohm resistor in parallel with RT5875. Key the transmitter and monitor the output power. The power meter should read approximately one-half the rated power (25 Watts).

3. Control-Voltage-Limit Circuitry Test

Disconnect J5901 (transmitter injection) from the internal transceiver chassis. This will require removal of the power amplifier assembly. With all other connections in normal condition, key the transmitter and monitor the control voltage at the node of R5811, C5814, L5808, and R5808. If the voltage exceeds 10.0 V, troubleshoot the control voltage limit circuitry.

4. Current-Limiting Circuitry Test

When ready to adjust current limit, decrease the relative current limit value with the keyboard per instructions. After several decrements, the current limit should begin to reduce power in 0.1- to 0.5-Watt increments. After this test, reset the current limit to its original value. If the circuitry does not perform as indicated, troubleshoot the current limit circuitry.

5. Power-Leveling Circuitry Test

With the radio connected for power measurements, vary the line voltage from 12.5 to 16 V. The power should not vary more than 2 Watts. At a line voltage of 13.6 V, vary the frequency using the three test modes. If power varies more than 2 Watts, measure the detected voltage on P0853, pin 9. If this voltage varies more than 0.2 V over line and frequency variations, the power control circuitry (most of which is located on the command board) may be malfunctioning. If the detected voltage varies less than 0.2 V, the problem is likely in diode CR5900, the harmonic filter, the antenna switch, or the output coax. Check continuity through the 12-pin DC connector P0853 on the PA board; check digital/analog circuitry, and check 5-V regulator operation. See [Table 4-20 on page 4-59](#) for typical values.

With the radio connected for power measurements and, disconnected TX injection coax, the detected voltage at P0853, pin 9, should measure approximately 1.3 V.

NOTE: If any part of the power leveling circuitry is replaced, perform the power set procedure. See the *ASTRO Digital Spectra and Digital Spectra Plus Mobile Radios Basic Service Manual* (6881076C20) for details.

4.5.3 800 MHz Band

4.5.3.1 15 Watt and 35 Watt Power Amplifiers

This information will help you troubleshoot the Spectra radio. Use this information, along with the Theory of Operation, to diagnose and isolate the cause of failures. The principle tools needed to troubleshoot a circuit to the component level are the schematic and the Theory of Operation.

In addition to the schematic and theory, this section includes troubleshooting information that will help you test and check the circuits to localize and isolate problems.

Prior to troubleshooting, it is important to review the Theory of Operation, including specific precautions and troubleshooting methods. Because much of the radio's circuitry operates at 800 MHz, measurements must be taken very carefully. Notes and cautions are added to the text to alert the reader to this need in areas of greatest sensitivity. However the need to extreme care does exist in all measurements and tests at 800 MHz.

4.5.3.1.1 General Troubleshooting and Repair Notes

Most of the common transmitter symptoms are caused by either failure of the power amplifier or a failure in the control circuitry. The initial troubleshooting effort should be toward isolating the problem to one of those two areas. If either the control voltage or keyed 9.4 V are zero, then the problem is likely to be in the control circuit. If those voltages are present, then the problem is more likely in the power amplifier circuit.

If for diagnostic reasons, a chip component needs to be removed to facilitate testing, such as a series capacitor removed to allow for signal insertion, then the component(s) returned to the circuit should be new parts. The application of a soldering iron to many chip components will tend to cause leaching which could lead to failure.

If the harmonic filter is damaged and needs to be replaced, then removal and replacement requires the use of a hot air source capable of reflowing the solder beneath the filter hybrid. When replacing it, add small amounts of fresh solder paste to the silver regions beneath the ceramic to assure adequate electrical ground contact. Save the original input and output connectors ('J' straps); these are not included with the replacement kit. No turning is required. The harmonic filter may be ordered separately, but if the PA kit is ordered, a filter kit comes with the PA kit.

The pass device may be ordered separately or may be received as part of the hardware kit-it is not part of the PA kit. The PA kit comes with all surface-mount components, including the harmonic filter hybrid, but the harmonic filter cover is not included. Neither does the PA kit include the Power Module, nor, on 35-Watt models, the final device and associated matching capacitors.

After a PA board is replaced, or if any power control circuitry components are replaced, readjust the power according to instructions in the *ASTRO Digital Spectra and Digital Spectra Plus Mobile Radios Basic Service Manual* (6881076C20).

NOTE: Due to the high frequency of operation, it is imperative that you use specified Motorola parts when component replacement is necessary. At these frequencies, second and third order properties of the components are very important and are part of the circuit's design. Substitute components may not work. It is also critical that you use great care when replacing parts. Excessive solder or flux, longer than original leads on coax connectors, misorientation of parts, and other commonly benign imperfections may cause the radio's performance to degrade.

4.5.3.1.2 PA Functional Testing

To test the PA assembly for proper operation, perform the following steps:

NOTE: The following instructions pertain to both the 15 Watt and 35 Watt power amplifiers. A distinction between the two PA's is given only where necessary.

1. Disassemble the PA assembly from the radio, leaving the power cable connected to the rear connector. Replace the 15-Watt PA shield (or the 35-Watt PA shield and cover). Disconnect the coax connectors and the ribbon cable. Connect a power meter to the antenna port using minimum cable length.

When setting or measuring RF power at 800 MHz, follow these guidelines to avoid measurement errors due to cable losses or non-50-ohm connector VSWR:

- All cables should be very short and have Teflon dielectric.
- Attenuators and 50-ohm loads should have at least 25 dB return loss.
- Mini UHF to 'N' adapter P/N 5880367B21, should be used at the antenna connector. All other connectors should be 'N' type. No other adapters, barrel connectors, etc. should be used.

Maximum input level to the PA is 200 mW. Over driving the buffer could result in damage to the PA buffer stage.

2. Apply the input power and DC voltages indicated in Table 4-23 to the power amplifier assembly. To make the DC connections, use small spring-clips or make a test adapter similar to that shown in Figure 4-10.

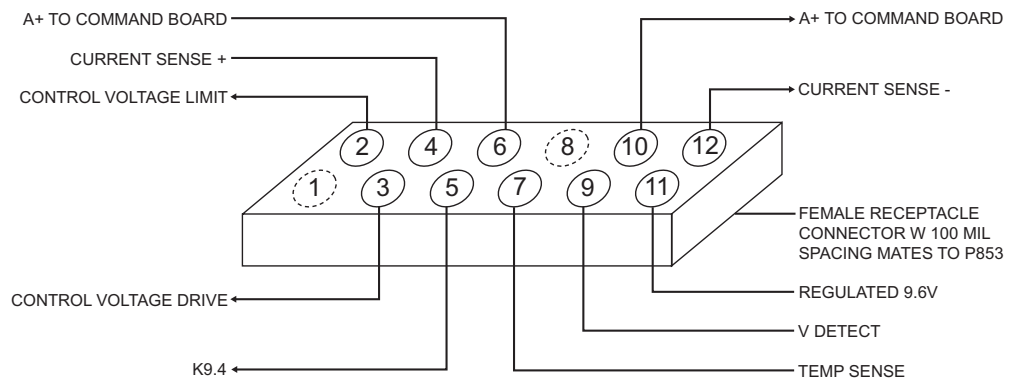

Figure 4-10. PA Test Adapter, 15 and 35 Watt Power Amplifier

Table 4-23. DC Voltages and Input Power Chart

Test	Keyed 9.4 V	9.6 V	CONTROL VOLTAGE DRIVE	POWER IN (mW)	A+ (V)
Transmit	9.4	9.6	See note ^a	0.1	13.0
Receive	0	9.6	0	0	13.0

a. Set initially to zero. Increase value until power equals 17 watts(15-Watt radio) or 38 Watts (35-Watt radio) or 11.0 V maximum.

3. Apply the required input power via adapter cable 30-80373B27 or equivalent. For this application, non N-type connectors are acceptable.
4. With the applied control voltage initially at 0 V slowly increase the voltage until power out equals 17 Watts (15-Watt radio) or 38 Watts (38-Watt radio) Power should rise smoothly with control voltage once the turn-on threshold is reached. Control voltage should no exceed 11.0 V.
5. If 11.0 V does not produce 17 (or 38) Watts, then a failure exists in the power amplifier circuit.
6. Refer to the voltage chart (see [Table 4-24](#)). Measure the indicated voltages. If they are not within the limits shown in the chart, then a failure exists in the PA assembly.
7. If the voltages in the chart are correct, verify that the injection is at least 75 mW. (See the VCO troubleshooting section.)
8. If no failure is located from the previous checks troubleshoot the power control circuitry.

Table 4-24. Power Control DC Voltage Chart

LOCATION	RX MODE			TX MODE			COMMENTS
	LOW	TYP	HI	LOW	TYP	HI	
P0853							
1	—	—	—	—	—	—	Key (no pin or wire)
2		0		0	2.0	3.2	Control Voltage Limit
3		0		2.0	7.0	13.0	Drive Voltage
4	10.8	13.6	16.5	10.0	13.0	16.0	Current Sense +
5	0	0	0	9.2	9.4	9.8	Keyed 9.4
6	10.8	13.6	16.5	10.8	13.6	16.5	A+ to Command Board
7		0			1.2		Temp Sense (cutback begins at 3.3 V)
8	—	—	—	—	—	—	Key (no pin)
9		0		1.3	3.5	6.0	Forward Detect Voltage
10	10.8	13.8	16.5	10.8	13.6	16.5	A+ to Command Board
11	9.4	9.6	9.9	9.4	9.6	9.9	9.6-V Supply from Command Board
12	20.8	13.6	16.5	10.0	13.0	16.0	Current Sense - (voltage delta 150 mV)
U0500							
1	0	0	0	0	0	0	Ground
2		0			3.2		Control AMP Input
3	0	0	0	0	0	0	Control AMP Input (not used)
4		0		0	2	3.2	Control Voltage Limit (cutback at 3.3 V)
5		0			0		N.C.
6	1.5	3.0	4.5	1.5	3.0	4.5	Power Set from D-A (max power at 1.5 V)

Table 4-24. Power Control DC Voltage Chart (Continued)

LOCATION	RX MODE			TX MODE			COMMENTS
	LOW	TYP	HI	LOW	TYP	HI	
7		0	0	1.5	3.0	4.5	Power Set Buffer Out
8		0		1.3	3.5	6.0	Coupler Buffer Out
9		0		1.3	3.5	6.0	Forward Detect Voltage
10		0			0		Reflected Power Detect (not used)
11		0		1.3	3.5	6.0	Same as pin 8 (not used)
12		0		0	1.2	6.0	Thermister Buffer out (increases as PA gets hot)
13		0		0	1.2	6.0	Thermister Buffer in
14		5.0			5.0		5-V Sense Input (follows pin 20 \pm 0.1 V)
15	4.9	5.0	5.7	4.9	5.0	5.7	5-V Current Limit (limits at 5.7 V)
16	5.0	5.7	6.4	5.0	5.7	6.4	5-V Series Pass Drive (6.4 at max current)
17	9.5	9.6	9.9	9.5	9.6	9.9	9.6-V Sense Input
18		7			7		5-V Reg. Compensation Capacitor
19		5.7			5.7		N.C.
20	4.9	5.0	5.1	4.9	5.0	5.1	5-V Reference Input (UNSW5-V)
21		1.2			1.2		9.6-V Reg. Compensation Capacitor
22		0			0		N.C.
23		0.9	9.6		1.2	9.6	9.6V Series Pass Drive
24		2.9			3.3		Regulator Enable/Compensation
25	—	—	—	—	—	—	9.6-V Programming (N.C.)
26		0			0		N.C.
27		13.6			13.6		N.C.
28	—	—	—	—	—	—	9.6-V Programming (N.C.)
29	—	—	—	—	—	—	9.6-V Programming (N.C.)
30	—	—	—	—	—	—	9.6-V Programming (N.C.)
31	0	0	0	0	0	0	Ground
32	10.8	13.6	16.5	10.0	13.0	16.0	Decoupled A+
33	4.0	5.0			0	0.2	TX PA Enable (from U520-25)
34		0			1.3		Control AMP one-shot
35		0			0		Lock (5-V of Synth Out of Lock)

Table 4-24. Power Control DC Voltage Chart (Continued)

LOCATION	RX MODE			TX MODE			COMMENTS
	LOW	TYP	HI	LOW	TYP	HI	
36		0			0.8		Control AMP one-shot
37	10.8	13.6	16.3	10.0	13.0	16.0	A+ (Current Sense +)
38	10.8	13.6	16.3	10.0	13.0	16.0	Current Sense - Voltage Delta 150 mV (35 Watt only)
39		0		9.2	9.4	9.8	Keyed 9.4-V in
40	1.5	3.0	4.5	1.5	3.0	4.5	Current Limit D-A (max current at 4.5 V)
41	0	0	0	0	0	0	Ground
42		0			2.2	9.6	Control AMP Output (Approx 1/2-V Control)
43		1.3			7.0		Loop Integrator Capacitor
44		2.1			3.2		Control AMP Reference
Q0500E		13.0			13.0		A+ - CR0500 Drop
Q0501C		12.3			12.3		VQ0500E - B/E Drop
Q0501E		0.2			0.2		V pin 23 - B/E Drop
Q0503E		0			1.5		V pin 42 - B/E Drop (TX)
Q0503C		13.6			9.0		
Q0504B		13.6			12.9		A+ - B/E Drop (TX)

NOTE: For antenna switch transmit bias conditions, RF drive must be removed from PA.

Table 4-25. Antenna Switch DC Voltage Chart

LOCATION		TYPICAL RX	TYPICAL TX NO PRE- DRIVE	COMMENTS
CR9920	ANODE	0	1.6	TX Series P.I.N. diode
	CATHODE	0	0.8	(on in TX mode)
CR9921	ANODE	0	0.8	TX Shunt P.I.N. diode
	CATHODE	—	—	(on in TX mode)
CR9922	ANODE	5.15V	<0.2	RX Series P.I.N. diode
	CATHODE	4.45V	8.7	(off in TX mode)
Q9920	COLLEC	5.15V	<0.2	

4.5.3.1.3 Localizing Problems

Failure locations often can be determined by externally measured symptoms. Basic symptoms are noted below with probable failure locations.

1. Low Power and High Current
 - Check for improper load conditions caused by high VSWR external to the radio.
 - Check output coax and mini-UHF connector.
 - Check harmonic filter and J-straps.
 - Check output impedance-matching circuitry from the final device to the harmonic filter.
2. Low Power and Low Current
 - If control voltage is greater than 10 V, then check per the above.
 - If control voltage is less than 10 V, then check the control circuitry.
3. Power Intermittently Low (or zero) and Current less than 1 A. when Power Drops
 - Check Buffer Stage.
4. Power Zero and Current greater than 5 A.
 - Check harmonic filter, antenna switch, and matching circuits beyond final stage.
5. Power Zero and Current between 2 and 5 A.
 - Check Power Module.
6. Power Zero and Current less than 1 A.
 - Check input coax.
 - Check Buffer Stage.

4.5.3.1.4 Isolating Failures

Methods of analyzing individual stages of the Power Amplifiers are detailed below. Most of the stages are Class C and must be analyzed under relatively high RF power levels. Generators capable of such levels may not be available in all service shops, therefore the tests below are arranged in order of increasing power. This tends to allow the preceding stage to be the source of RF power for testing the next stage. If adequate power sources are available, then any stage may be tested with external signal injection.

1. Testing Buffer Circuitry

The required DC and RF conditions are defined in [Table 4-23 on page 4-67](#). With no RF input applied, the collector voltage of Q9800 should be 9.4V. If not, check L9805, L9801, and the feed runners. The base voltage should be 0.6-V (0.7-V without RF). If not, check R9801, CR9800, and related adaptive bias circuitry.

To check for power out, remove R9805 and lift the output end of C9807. Solder the center conductor of a small-diameter 50-ohm, coax to the vacated pad on the buffer side. Solder the coax's shield to ground. Under the conditions specified in [Table 4-23 on page 4-67](#), the measured power should be at least 350 mW. After output power has been tested, replace the resistor and capacitor with new parts.

An alternate method of testing the buffer's power out is to carefully lift the input lead of the power module (pin 1) from the circuit board and replace it with the center conductor of a small-diameter coax. Solder the shield of the coax. Solder the shield of the coax to the adjacent ground pad.

To test the input VSWR of the circuit, apply 70 mW to the input. Using a directional coupler, verify that the reflected power is less than 20 mW.

2. Testing the Power Module (U9850)

The power module is a packaged gain block with 50-ohm input and output impedances. It has three gain stages, the first two of which have controlled voltage applied (for regulating power) and the final stage has A+ applied.

If the buffer stage has not been confirmed in "working order," an external 400 mW must be injected. Do this by carefully lifting pin 1 of the power module and soldering the center conductor of a small diameter coax to the pin. Solder the shield to the ground pad adjacent to pin 1. To this cable, inject 400 mW. (This application is not so critical to require an 'N' connector on the loose end of the coax.)

If the buffer stage is confirmed in "working order," then provide 100 mW drive to the buffer (K9.4-V must be applied) to drive the module.

To measure the output power from the module, remove the series DC blocking capacitor C9879 (15W) or C9856 (35W), then connect a 39 pF blocking capacitor from the center conductor of a small diameter coax to the vacated pad, and finally, ground the shield of the output coax. Use this coax to measure output power.

Control voltage (Pins 2 and 3) should be 10 V; A+ (pin 4) should be 13.0 V. Apply voltages through the DC connector on the PA board.

With either 100 mW applied to the buffer or 400 mW applied to the module input, the output power should be at least 15 Watts. If power out is less than 15 Watts, the module is defective and must be replaced.

NOTE: When replacing the module, apply thermal compound on the heatsink surface. Torque the screws to the correct value; see the *ASTRO Digital Spectra and Digital Spectra Plus Mobile Radios Basic Service Manual (6881076C20)*.

When testing is complete, replace any capacitors or resistors that were removed for testing with new parts.

3. Testing the Final Stage (35-Watt Models Only)

The final stage is capable of producing over 50 Watts. Be sure to protect power measuring equipment with series attenuation. 30 dB is usually adequate.

15 Watts are needed to drive the final stage. Because this may exceed the power available at 800 MHz in many repair facilities, these tests consider the module stage as the drive source for the final stage. Therefore, check out the module first to ensure that it operates properly.

In the course of testing the final stage with the module as the power source, begin with control voltage at zero and increase control voltage smoothly until output of the final stage reaches 40 Watts. If control voltage reaches 10 V, but the power out does not reach 40 Watts, the final stage is defective. Under normal conditions, the protection circuitry limits the power to the final stage to approximately 17 Watts maximum, protecting it from overdrive and damage. Under test conditions, however, the protection circuitry is disabled. Observe the above caution; the power module can produce in excess of 25 Watts.

Measure the output power by lifting the output side of C9856 and connecting to the center conductor of a small-diameter coax which has its shield grounded. If the output stage does not produce 40 Watts (at 10-V control voltage), then remove the RF drive and perform the following tests:

- Check continuity from the collector lead to the A+ connector on the back of the radio.
- Examine the solder connections on all leads of the device (Q9880) and the clamped mica capacitors.

NOTE: The position of the clamped capacitors adjacent to the device is critical to the performance of the circuit. If they are removed for any reason, they must be re-installed with their leads approximately 70 mil s (0.070 inches) from the final device cap.

4. Testing the Antenna Switch and Harmonic Filter

Verify that most of this circuit is functioning properly by testing the receiver insertion loss as follows:

- Apply a low-level signal source at the antenna connector.
- Apply the conditions indicated in [Table 4-23 on page 4-67](#) for RX tests.
- Measure the power at the receive coax.
- If the difference between the input and output (insertion loss) is less than 2 dB, then the circuitry is functioning properly.

Additional antenna switch tests are:

- Check CR9922 with an ohmmeter for forward and reverse continuity.
- In the transmit mode, adjust control voltage for 38 Watts at the antenna connector. Check for less than 10 mW at the end of the receive input cable. If power exceeds 10 mW, then check CR9922 and associated circuitry. Receiver sensitivity can degrade if power at this port exceeds 10 mW.
- Check for proper DC current through the PIN diodes; correct current is indicated if approximately 1.5 V is present at the junction of C9920 and L9920 during transmit mode.

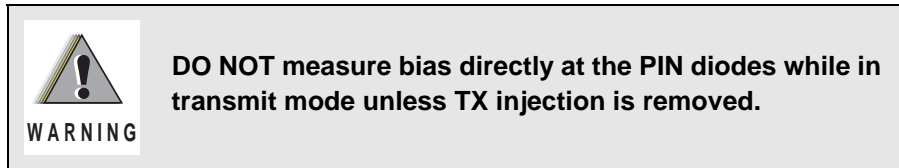

4.5.3.1.5 Power Control and Protection Circuitry

1. Localizing Problems to a Circuit

Power leveling and current limiting (35-Watt models only) are set to values detailed in the *ASTRO Digital Spectra and Digital Spectra Plus Mobile Radios Basic Service Manual* (6881076C20). These values will vary from unit to unit, depending on the unique variations of each unit. If symptoms indicate that either of these circuits have failed, verify that the radio has been properly aligned before investigating the circuitry.

Temperature sense, voltage control limit, and interstage drive limit (on 35-Watt models only) are fixed by design and are not influenced by the alignment of the radio. If symptoms indicate that these circuits have failed, then troubleshoot the circuit.

The tests that follow are intended to provide a convenient means of verifying that a particular circuit is functioning properly. These tests will isolate the failure to a minimum number of components. Refer to the Theory of Operation and the schematic for information needed to identify the failed component(s).

2. Temperature Sense Circuit Test

Temporarily install a 6.8k ohm resistor in parallel with RT9650. Key the transmitter and monitor the output power. The power meter should read approximately 1/2 the rated power (7.5 Watts or 17.5 Watts).

3. Control-Voltage-Limit Circuitry Test

Disconnect P9641 (Transmitter injection) from the internal transceiver chassis. This will require removal of the power amplifier assembly. With all other connections in normal condition, key the transmitter and monitor the control voltage on pin 2 of the power module. If the voltage exceeds 12.5 V, troubleshoot the control voltage limit circuitry.

4. Interstage Drive Limiter Circuitry Test (35-Watt models)

Check this circuit only when the final device Q9880) has failed. With the radio off, check CR9930 and associated components.

5. Current-Limiting Circuitry Test (35-Watt models)

When ready to adjust current limit, decrease the relative current limit value with the keyboard per instructions. After several decrements, the current limit should reduce power from 0.1 Watt to 0.5 Watt. After this test, reset the current limit. If the circuitry does not perform as indicated, troubleshoot the current limit circuitry.

6. Power-Leveling Circuitry Test

With the radio connected for power measurements, vary the line voltage from 12.5 to 16 V. The power should not vary more than 3 Watts. At a line voltage of 13.6 V, vary the frequency using the three test modes. If power varies more than 3 Watts, measure the detected voltage on P0853, pin 9. If this voltage varies more than 0.2 V over line and frequency variations, the power control circuitry (most of which is located on the command board) may be malfunctioning. If the detected voltage varies less than 0.2 V, the problem is likely in CR9900, the harmonic filter, the antenna switch, or the output coax. Check continuity through 12 pin DC connector P0853 on the PA board; check digital/analog circuitry, and check 5-V regulator operation. See [Table 4-24 on page 4-68](#) for typical values.

NOTE: If any part of the power leveling circuitry is replaced, perform the power set procedure. See the *ASTRO Digital Spectra and Digital Spectra Plus Mobile Radios Basic Service Manual* (6881076C20) for details.

Notes

Chapter 5 Troubleshooting Charts

5.1 Introduction

This chapter contains detailed troubleshooting flowcharts. These charts should be used as a guide in determining the problem areas. They are not a substitute for knowledge of circuit operation and astute troubleshooting techniques. It is advisable to refer to the related detailed circuit descriptions in the theory section prior to troubleshooting a radio.

5.2 List of Troubleshooting Charts

Most troubleshooting charts (see [Table 5-1](#)) end up by pointing to an IC to replace. **It is not always noted, but is good practice, to verify supplies and grounds to the affected IC, and trace continuity to the malfunctioning signal and related circuitry before replacing any IC.** For instance, if a clock signal is not available at a destination IC, continuity from the source IC should be checked before replacing the source IC.

Table 5-1. List of Troubleshooting Charts

Chart	Description	Page
Chart C.1	RF Board Back-End	5-3
Chart C.2	Command Board	5-4
Chart C.3	Radio Power-Up Fail	5-5
Chart C.4	Bootstrap Fail	5-6
Chart C.5	01/90, General Hardware Failure	5-7
Chart C.6	01/81, Host ROM Checksum Failure	5-7
Chart C.7	01/82, or 002, External EEPROM Checksum Failure	5-8
Chart C.8	01/84, SLIC Initialization Failure	5-8
Chart C.9	01/88, MCU (Host μ C) External SRAM Failure	5-9
Chart C.10	01/92, Internal EEPROM Checksum Failure	5-9
Chart C.11	02/A0, ADSIC Checksum Failure	5-10
Chart C.12	02/81, DSP ROM Checksum Failure	5-10
Chart C.13	02/88, DSP External SRAM Failure U414	5-11
Chart C.14	02/84, DSP External SRAM Failure U403	5-11
Chart C.15	02/82, DSP External SRAM Failure U402	5-12
Chart C.16	02/90, General DSP Hardware Failure	5-12
Chart C.17	09/10, Secure Hardware Failure	5-13
Chart C.18	09/90, Secure Hardware Failure	5-13
Chart C.19	No RX Audio	5-14

Table 5-1. List of Troubleshooting Charts (Continued)

Chart	Description	Page
Chart C.20	No TX Modulation	5-15
Chart C.21	Key Load Fail	5-16
Chart C.22	800 MHz Receiver Front-End Hybrid	5-17
Chart C.23	UHF Receiver Front-End Hybrid	5-17
Chart C.24	VHF Receiver Front-End Hybrid	5-18
Chart C.25	ASTRO Spectra Plus VOCON Power-Up Failure	5-19
Chart C.26	ASTRO Spectra Plus VOCON DC Supply Failure	5-20
Chart C.27	ASTRO Spectra Plus VOCON TX Modulation Failure Sheet 1 of 4	5-21
Chart C.28	ASTRO Spectra Plus VOCON TX Modulation Failure Sheet 2 of 4	5-22
Chart C.29	ASTRO Spectra Plus VOCON TX Modulation Failure Sheet 3 of 4	5-23
Chart C.30	ASTRO Spectra Plus VOCON TX Modulation Failure Sheet 4 of 4	5-24
Chart C.31	ASTRO Spectra Plus VOCON RX Audio Failure	5-24
Chart C.32	ASTRO Spectra Plus VOCON Secure Hardware Failure	5-25
Chart C.33	ASTRO Spectra Plus VOCON Key Load Fail	5-26

NOTE: The term μC is used in several of the following troubleshooting charts;
 $\mu\text{C} = \text{MCU}$.

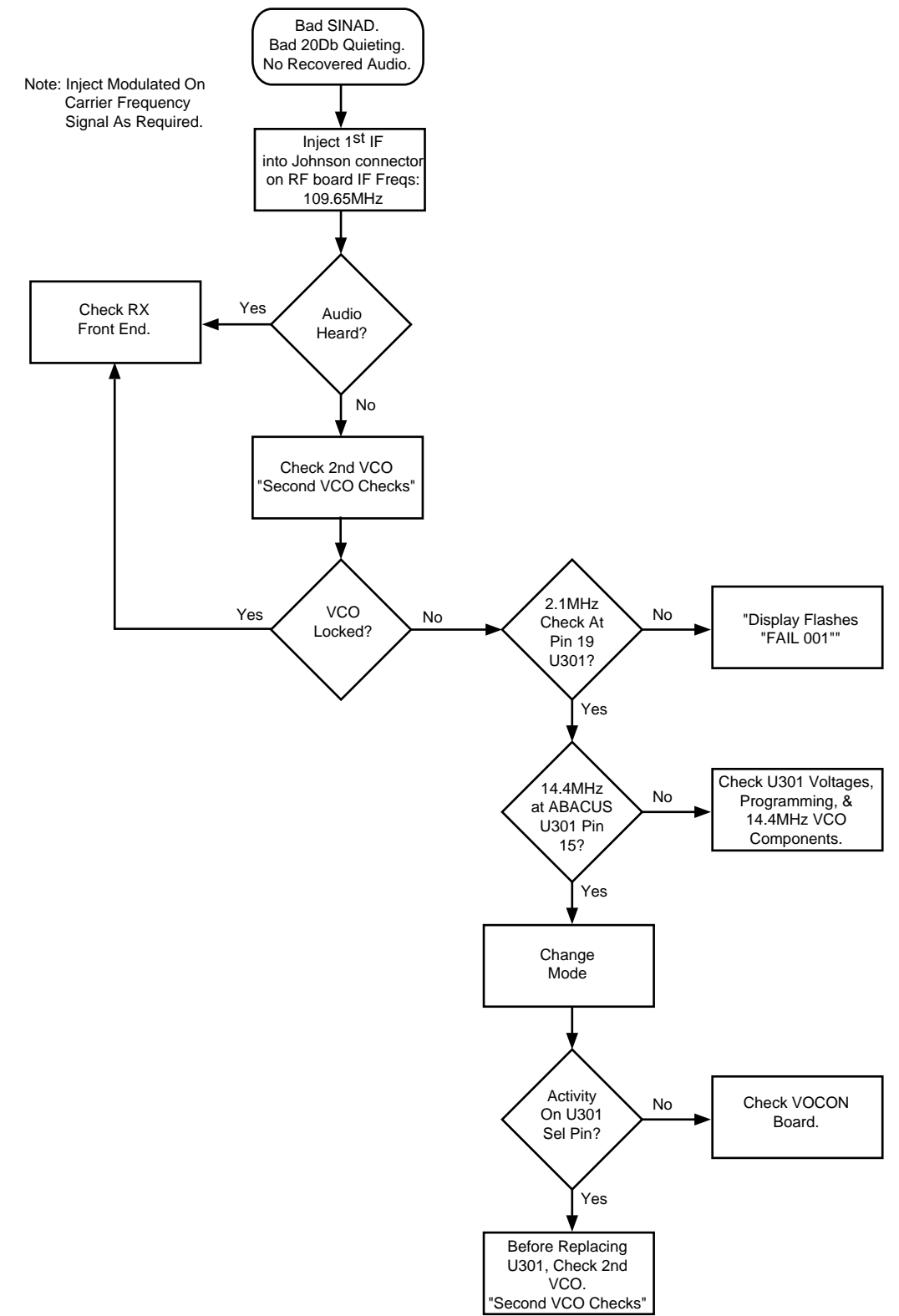

MAEPF-25192-A

Chart C.1 RF Board Back-End

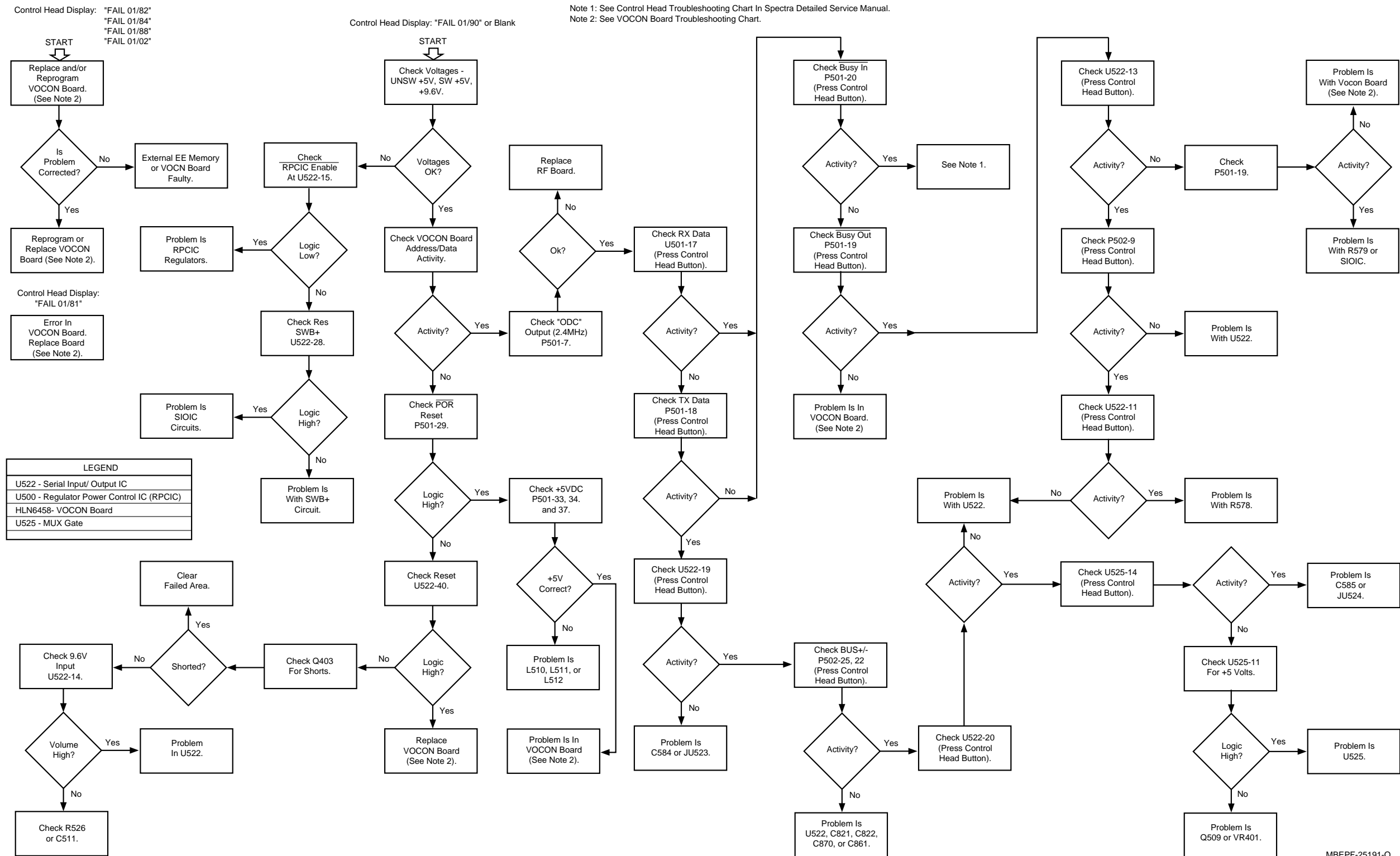

Chart C.2 Command Board

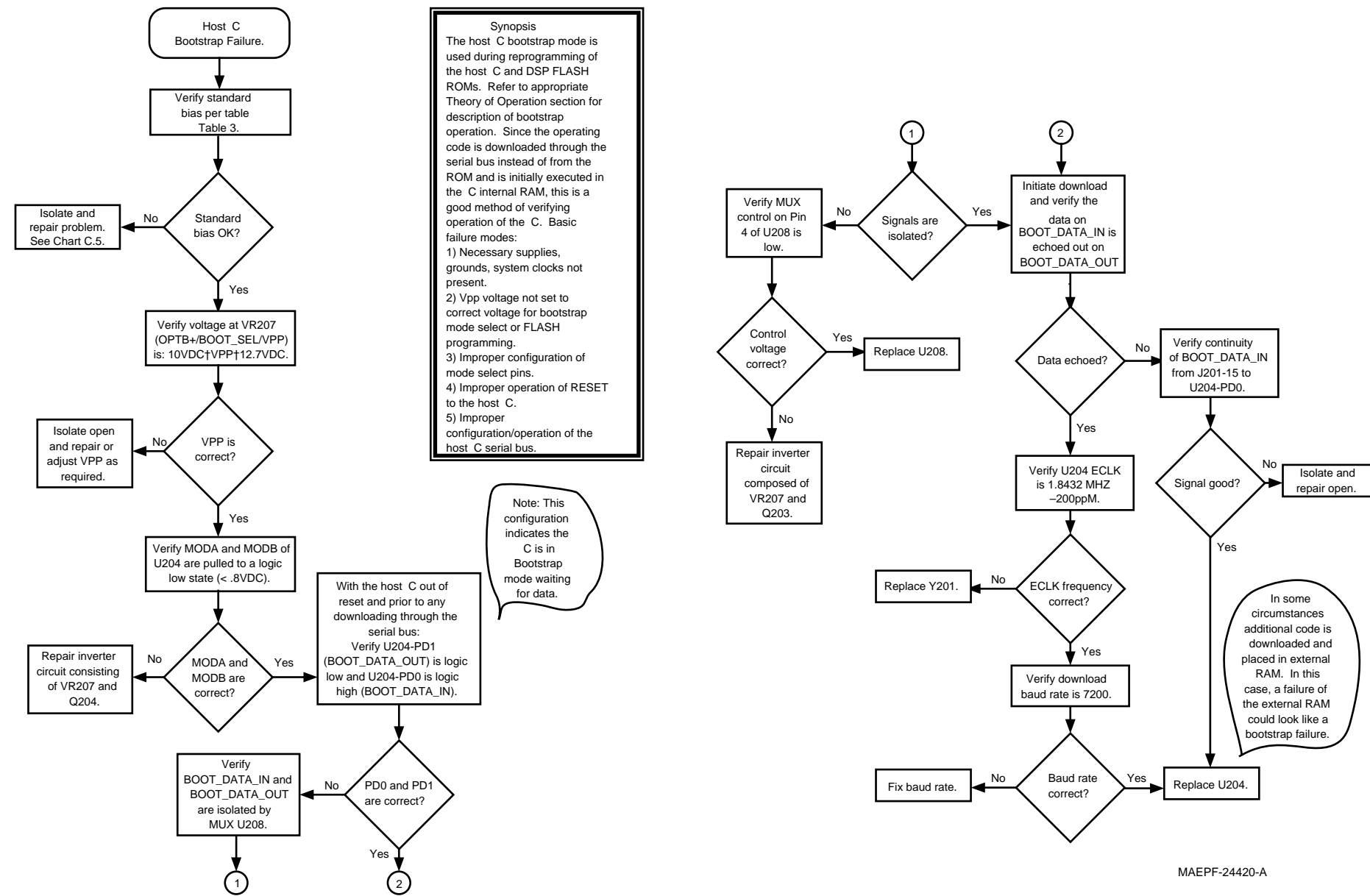
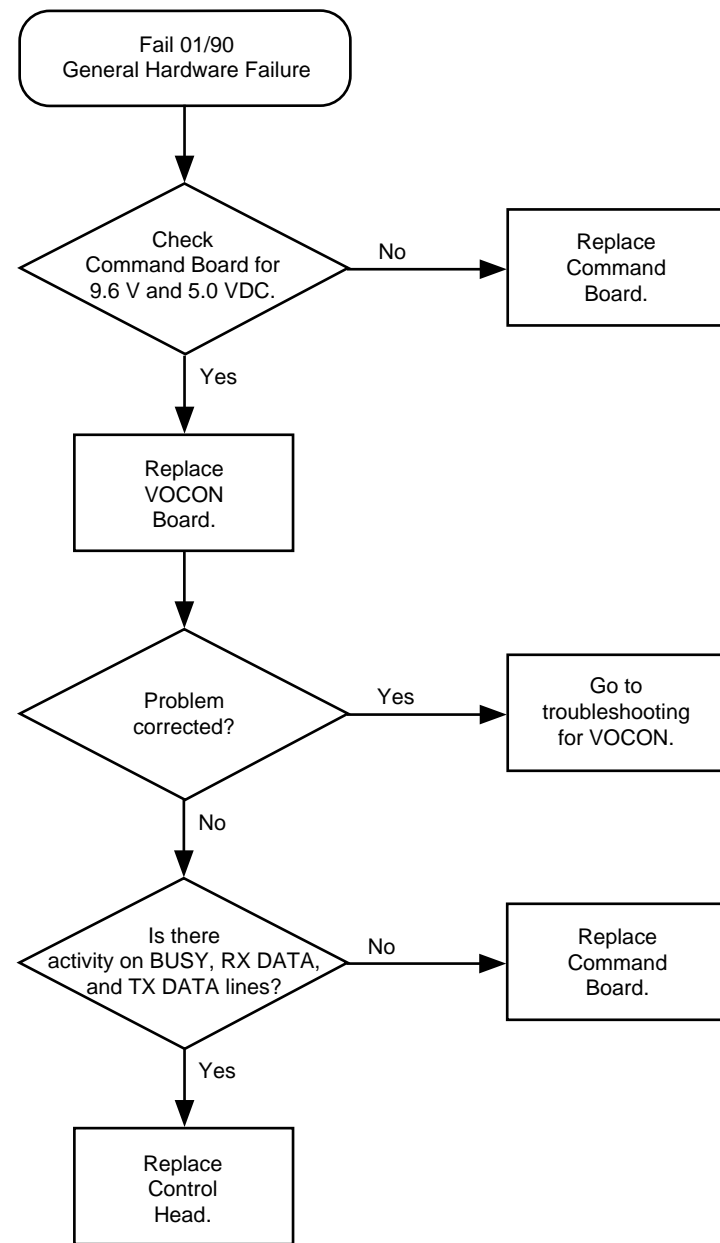
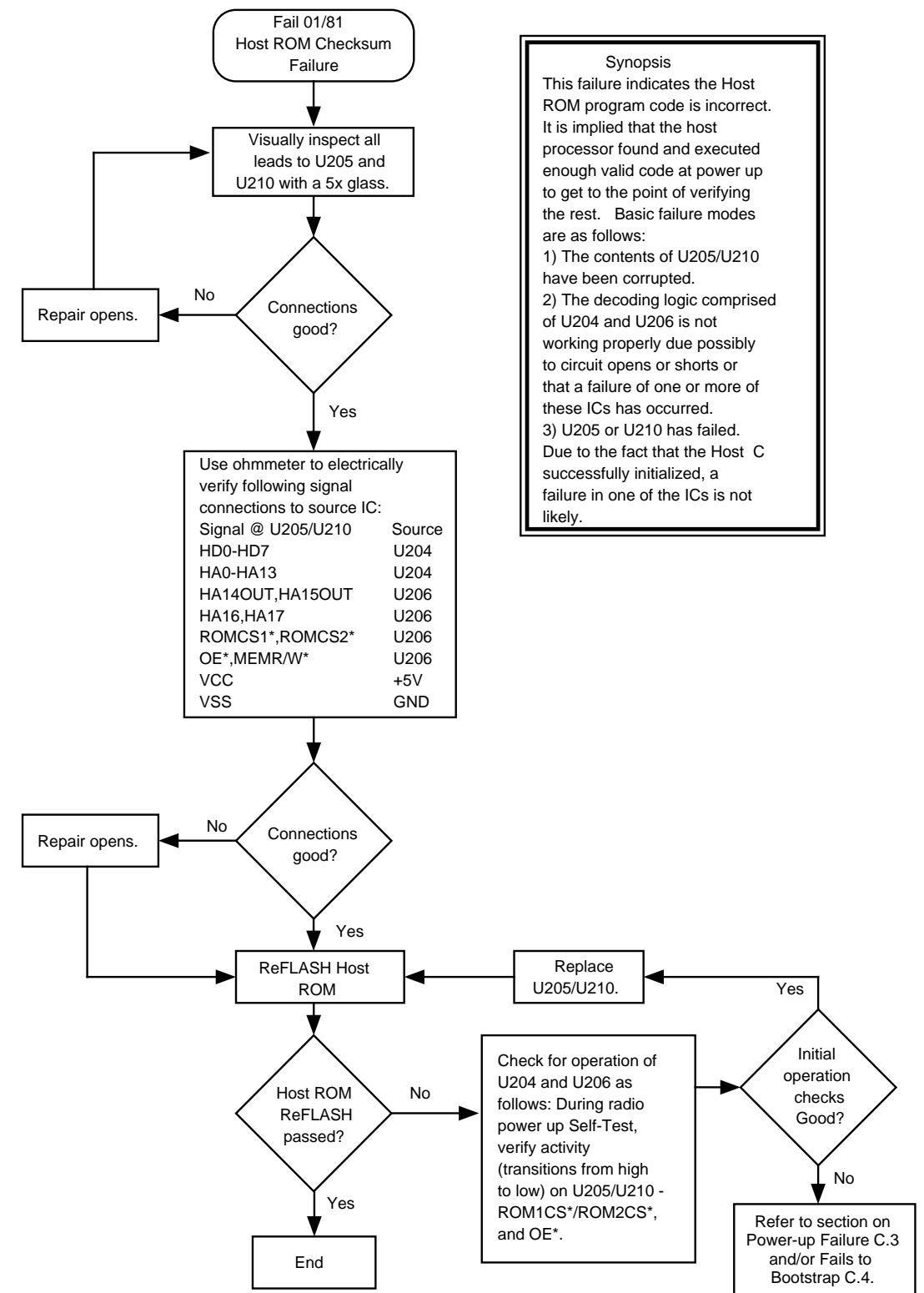

Chart C.4 Bootstrap Fail



MAEPF-25209-O

Chart C.5 01/90, General Hardware Failure



MAEPF-24421-A

Chart C.6 01/81, Host ROM Checksum Failure

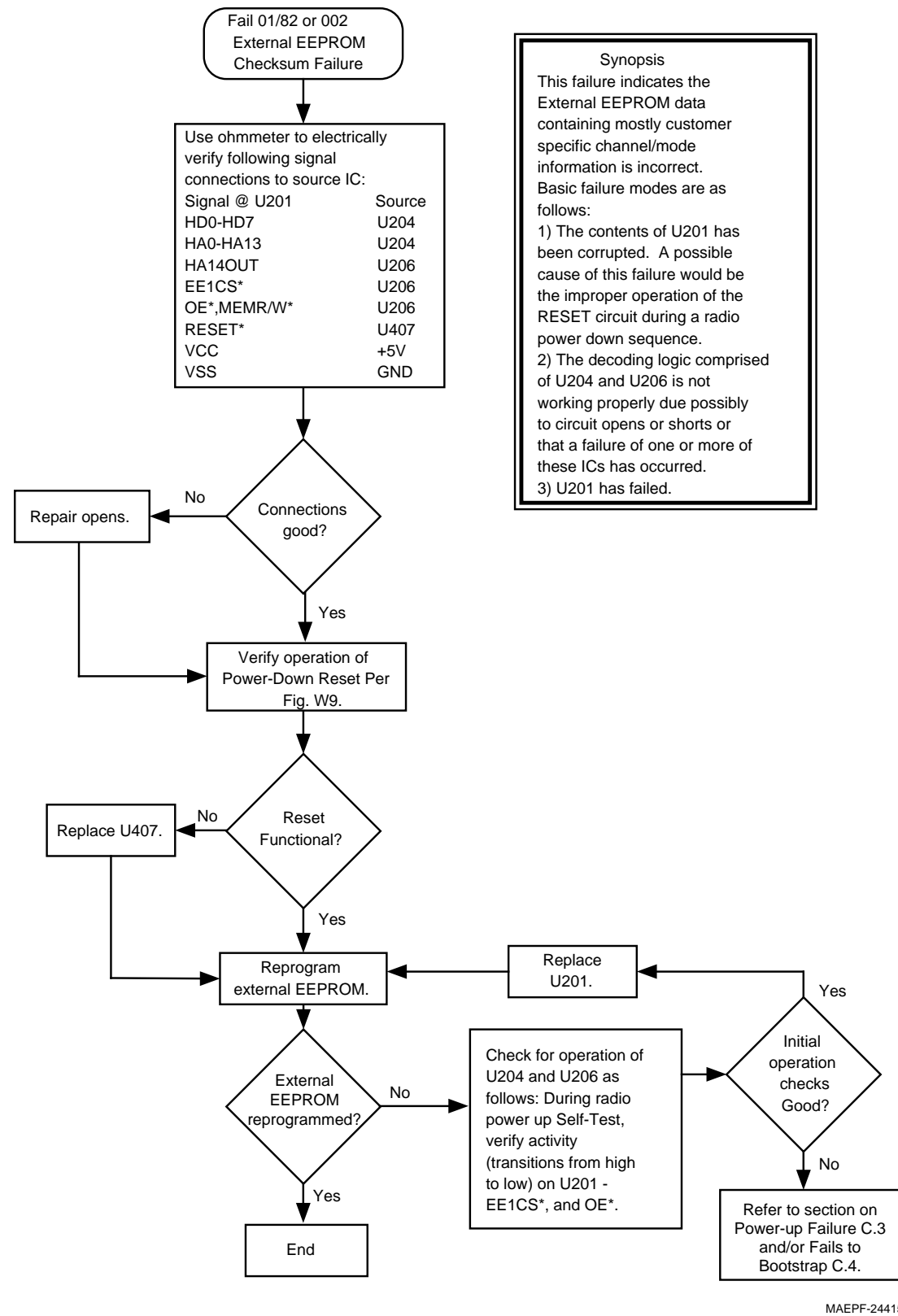

Chart C.7 01/82 or 002, External EEPROM Checksum Failure

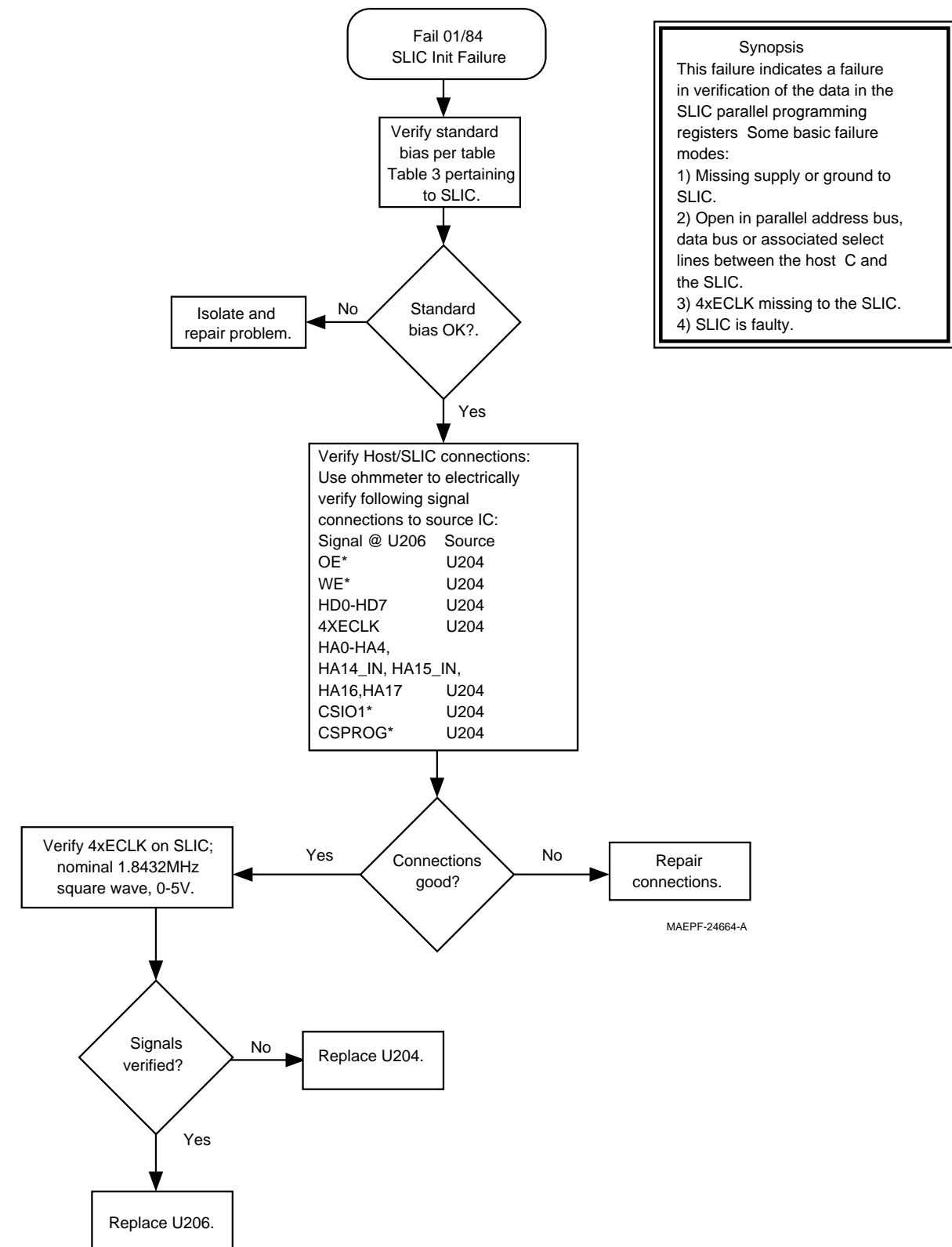
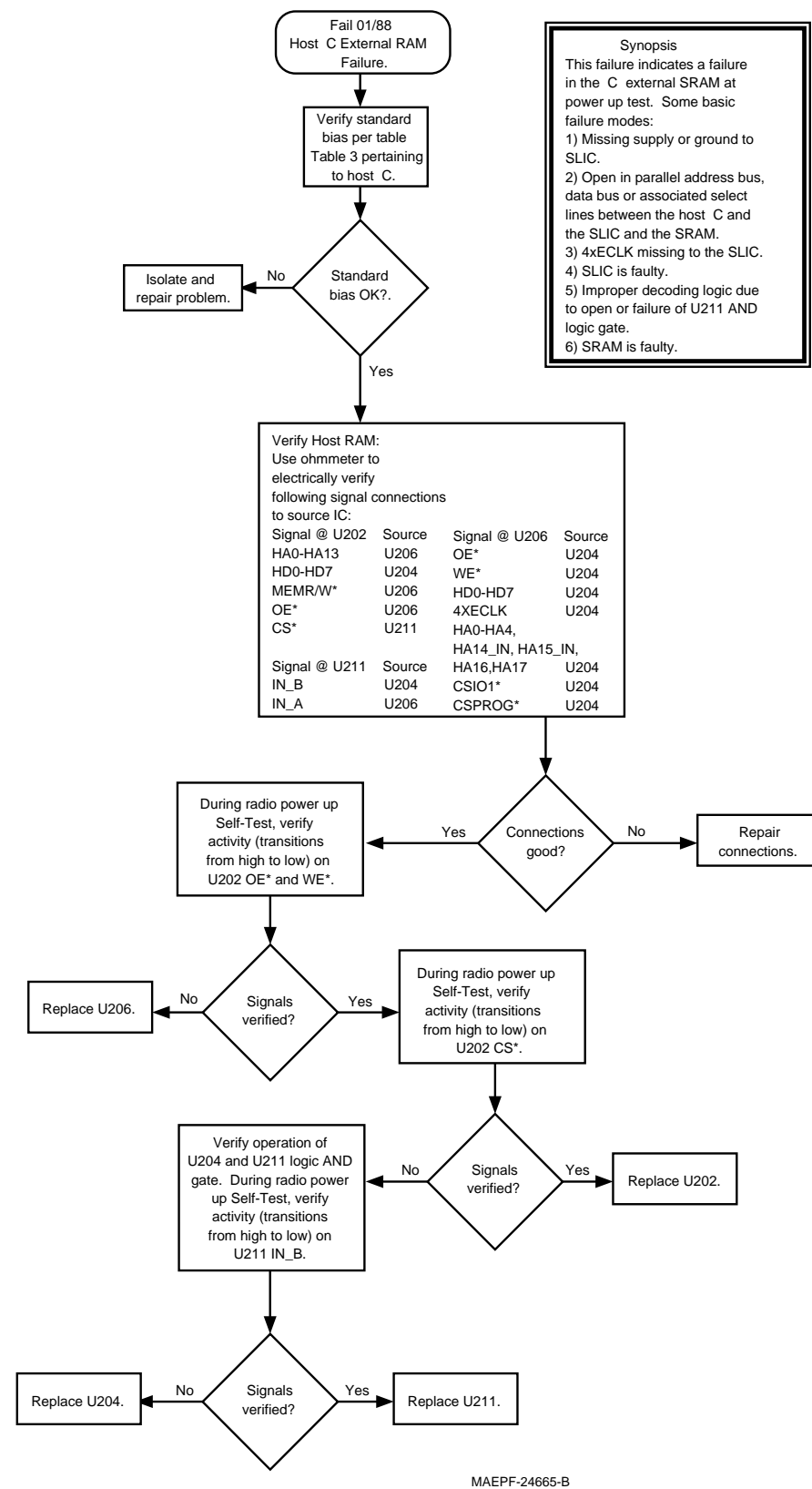
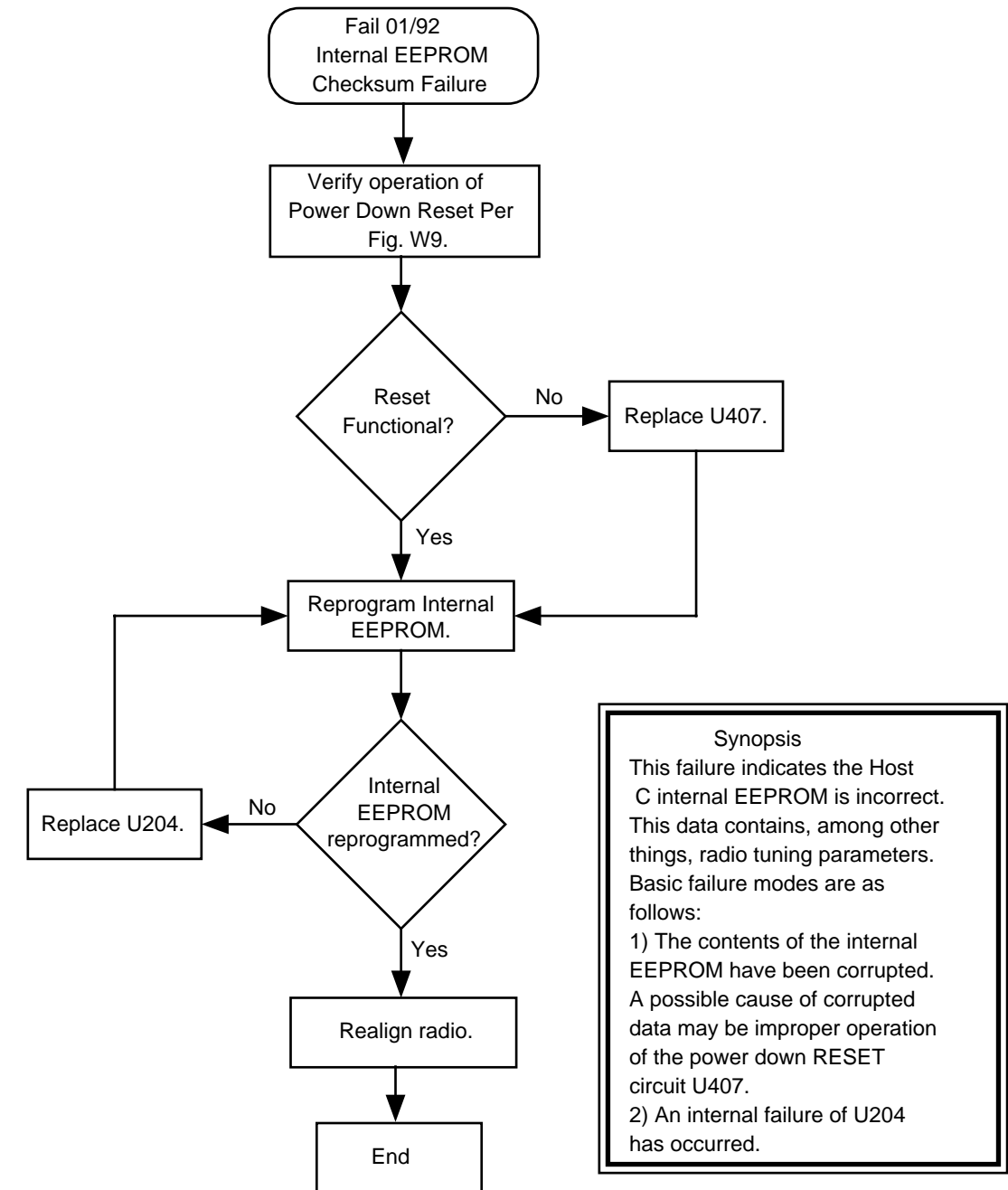

Chart C.8 01/84, SLIC Initialization Failure



MAEPF-24665-B

Chart C.9 01/88, MCU (Host mC) External SRAM Failure



MAEPF-24407-B

Chart C.10 01/92, Internal EEPROM Checksum Failure

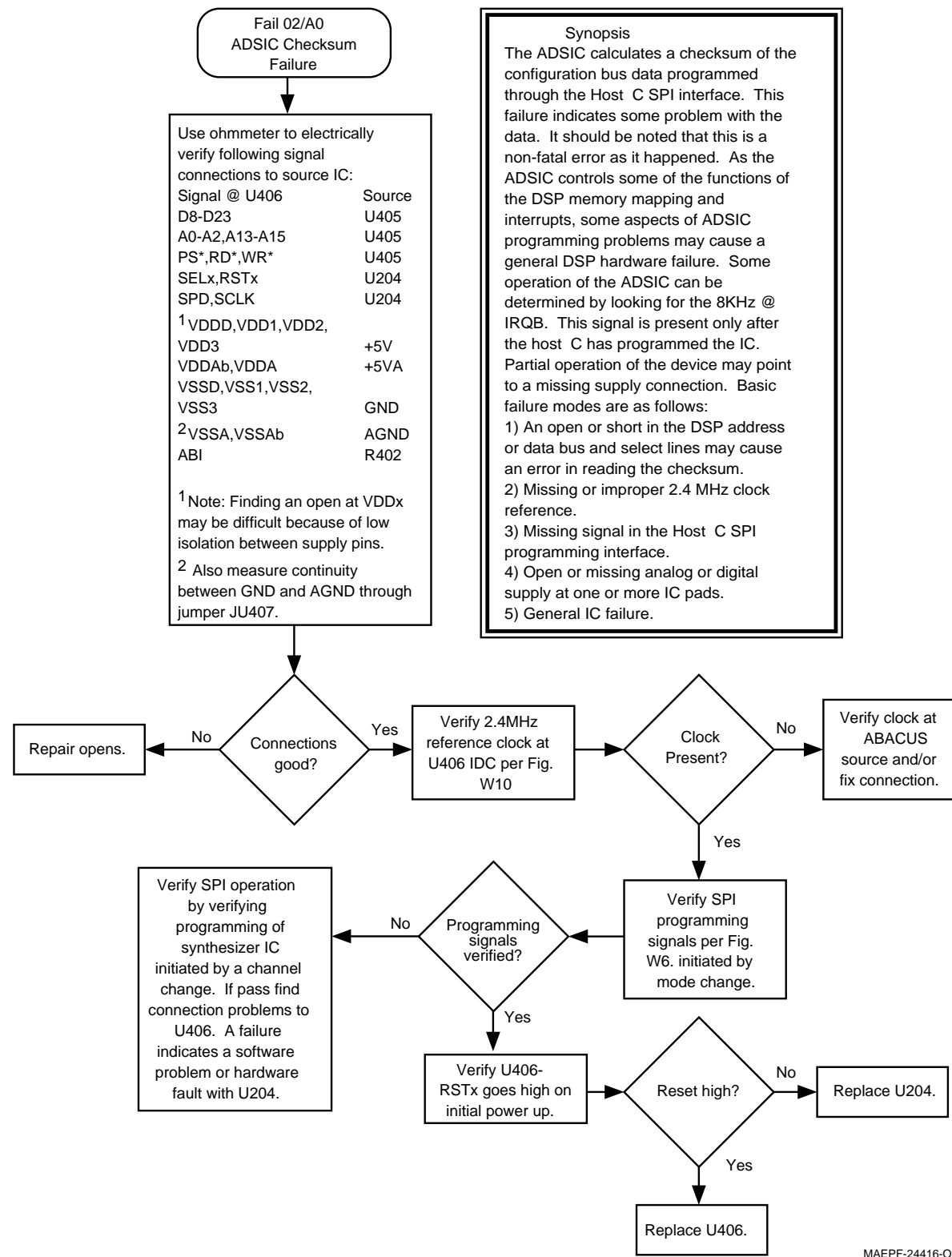

Chart C.11 02/A0, ADSIC Checksum Failure

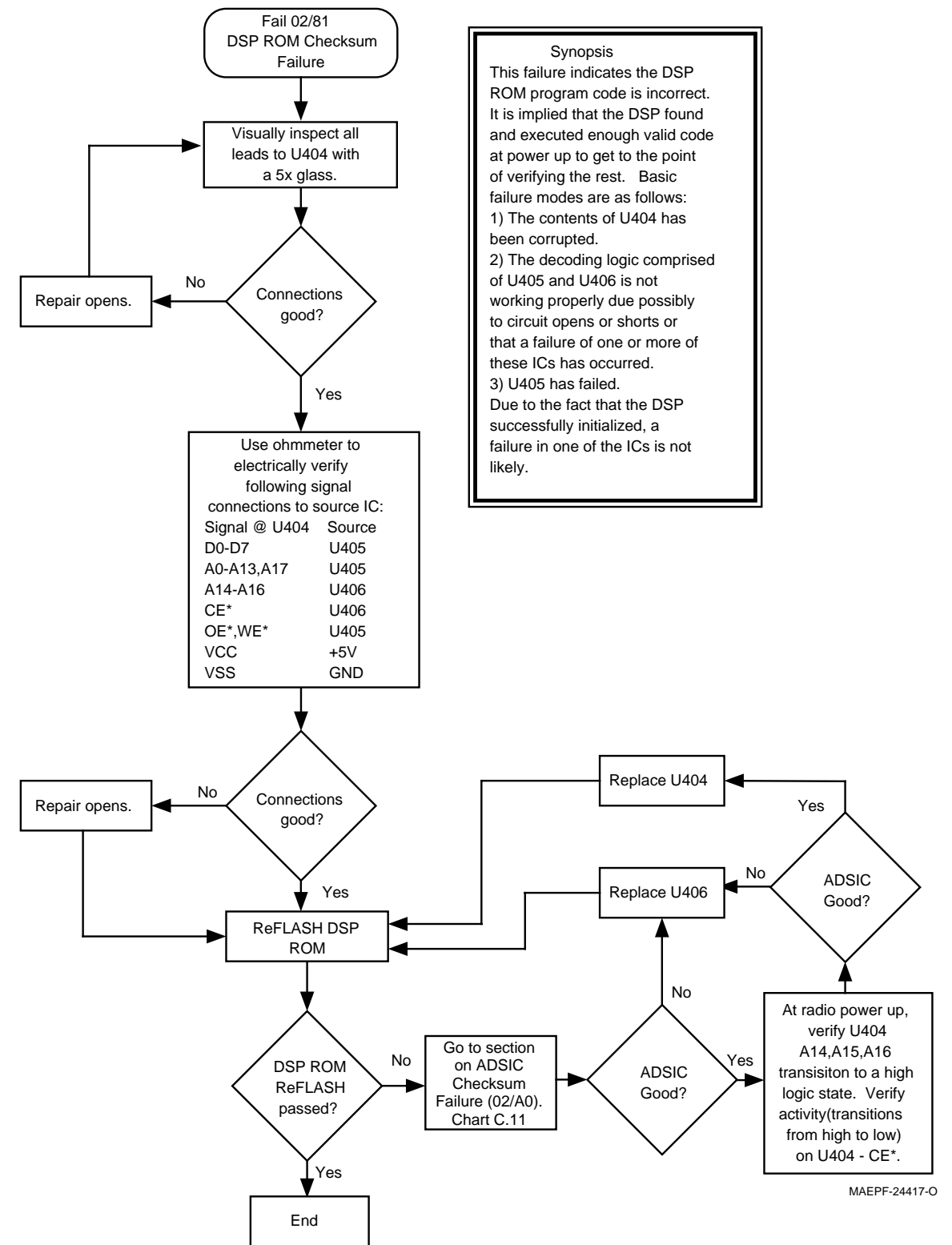
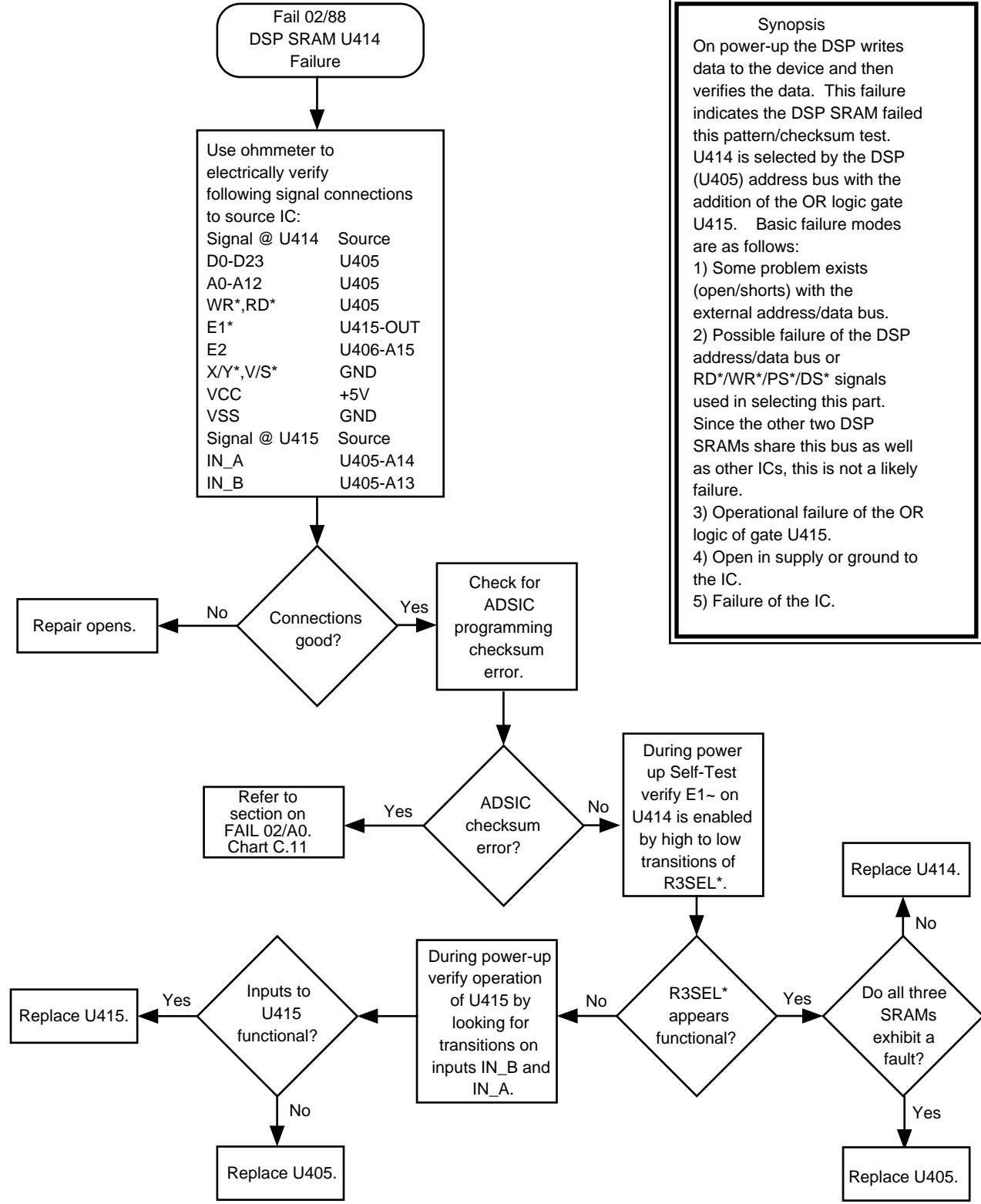
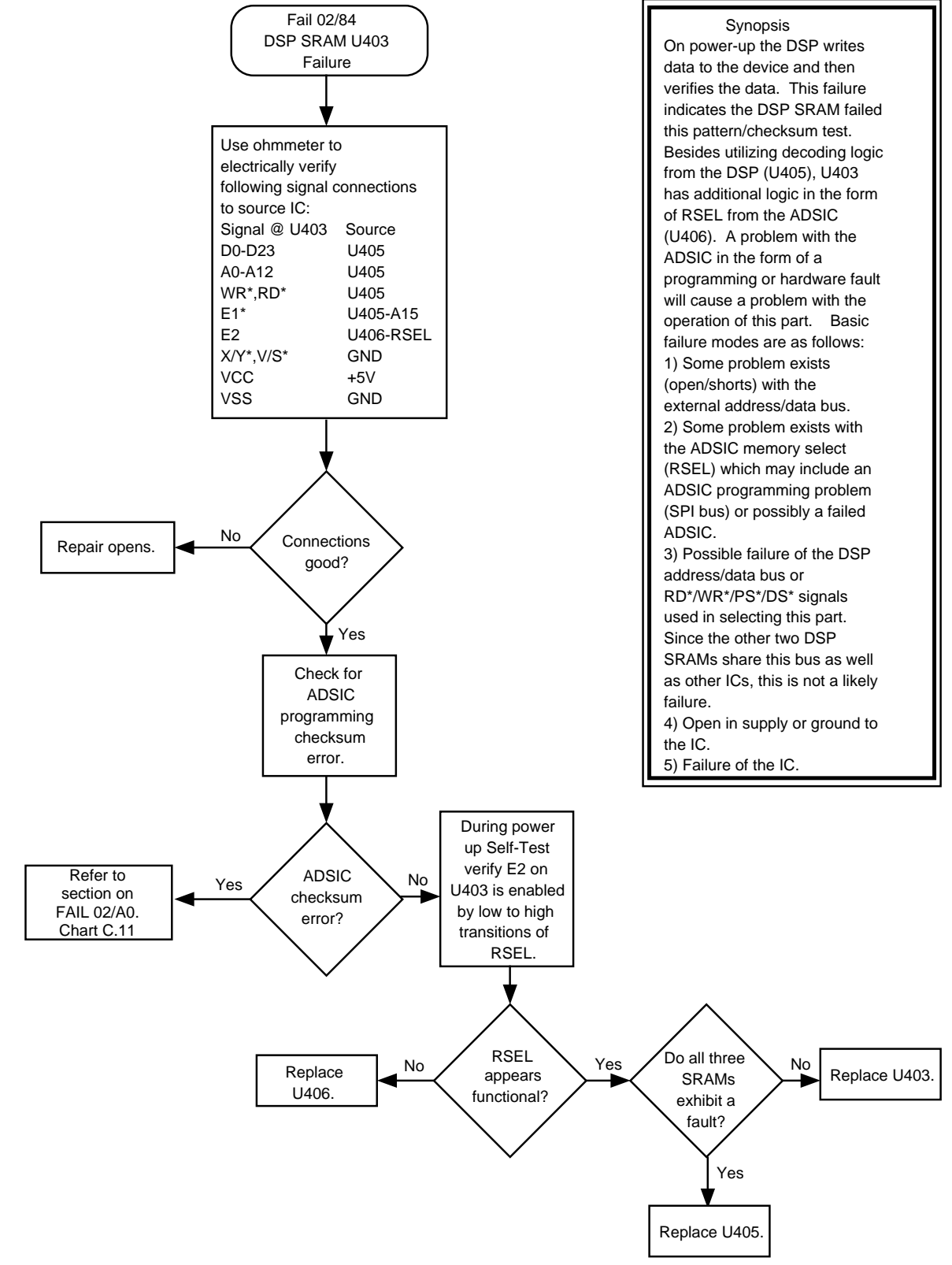

Chart C.12 02/81, DSP ROM Checksum Failure



MAEPF-24410-B

Chart C.13 02/88, DSP External SRAM Failure U414



MAEPF-24409-B

Chart C.14 02/84, DSP External SRAM Failure U403

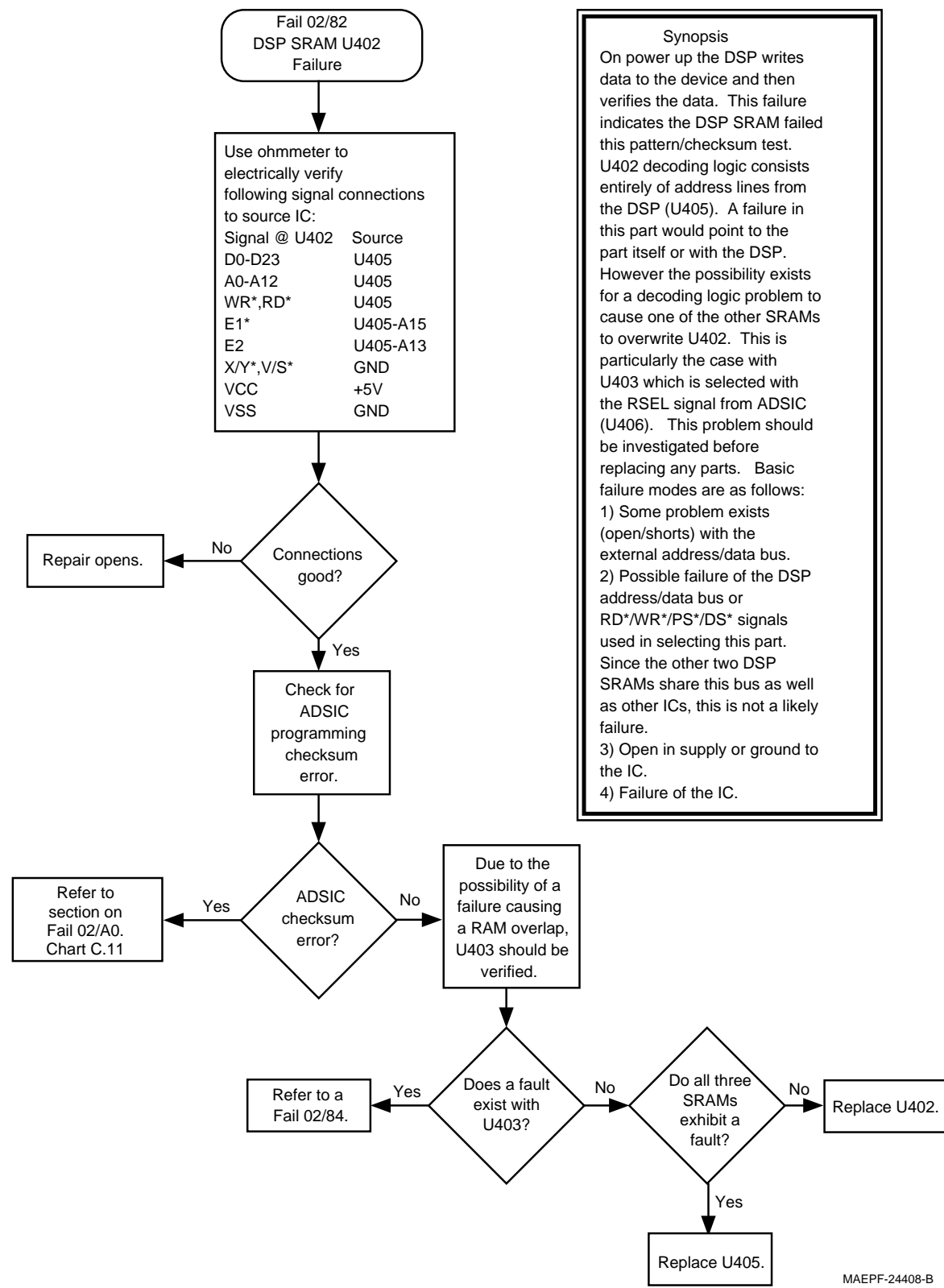

Chart C.15 02/82, DSP External SRAM Failure U402

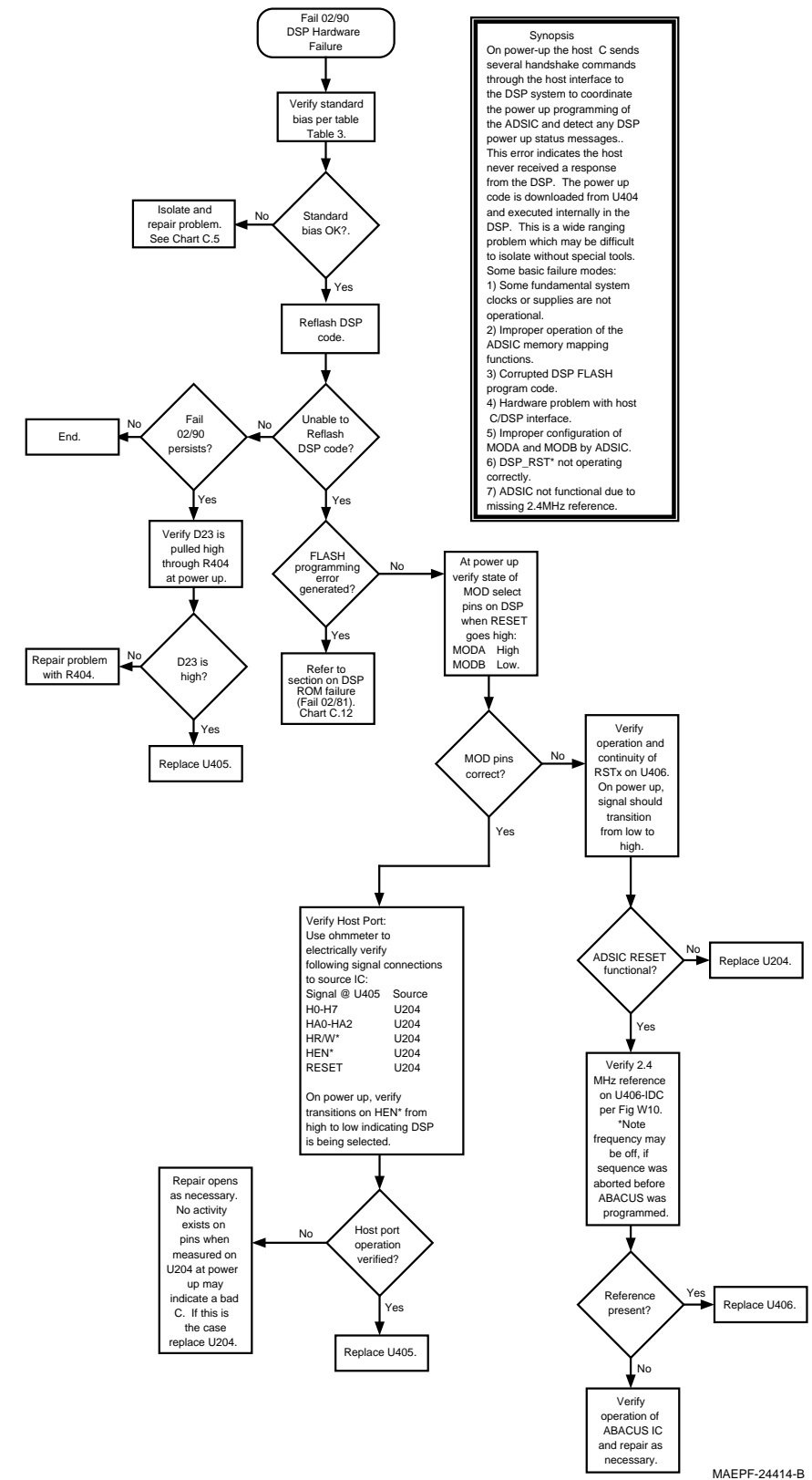

Chart C.16 02/90, General DSP Hardware Failure

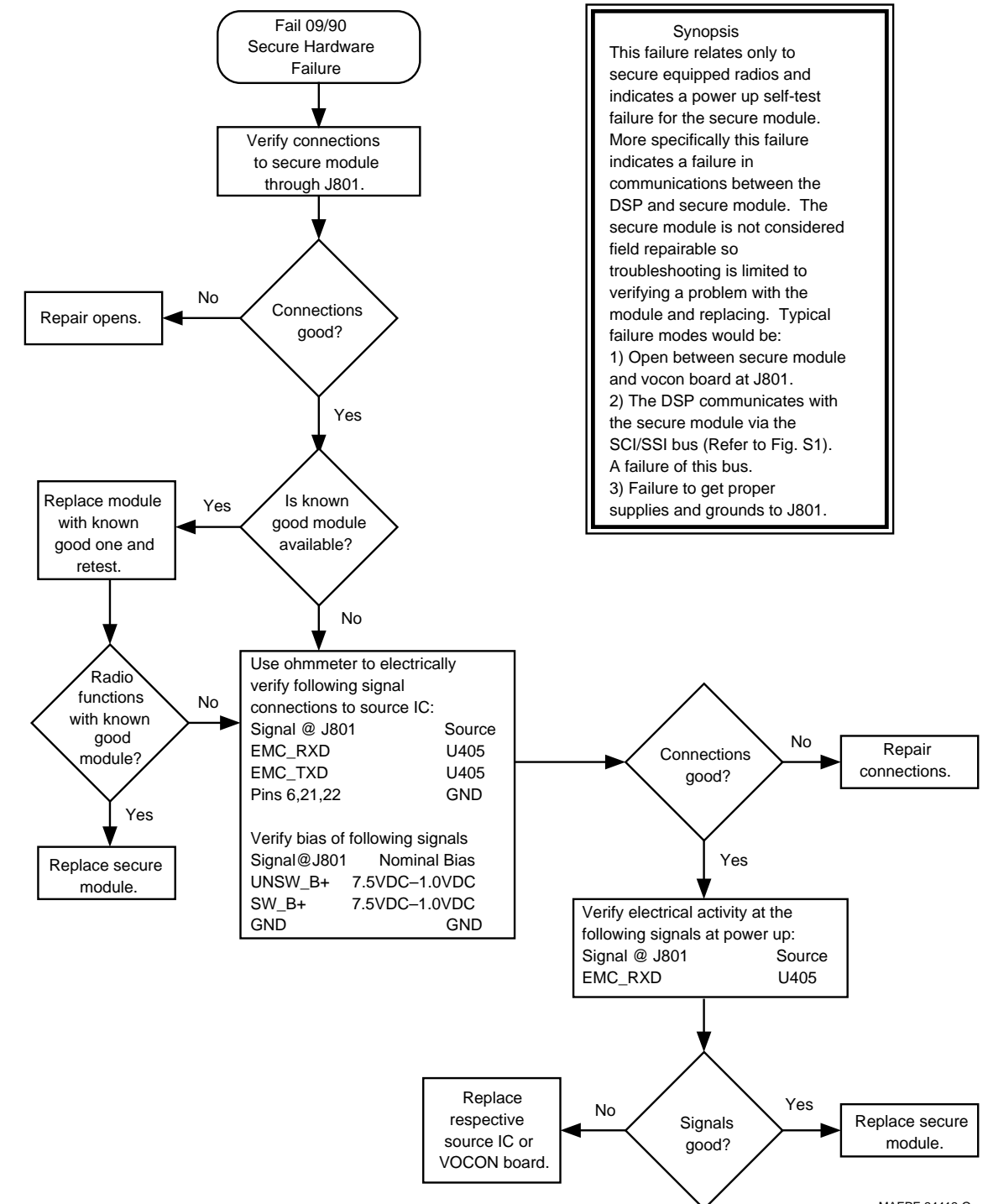
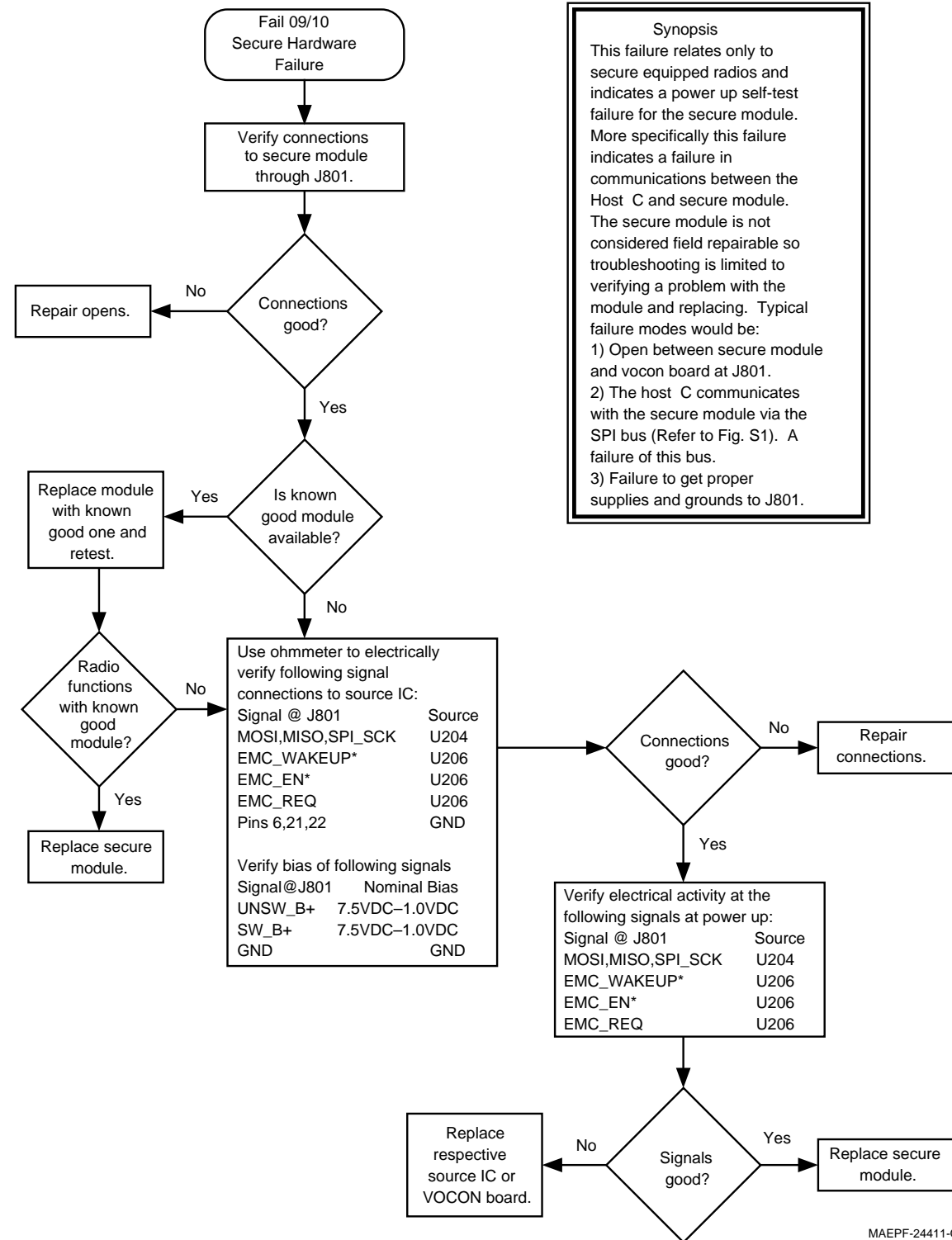
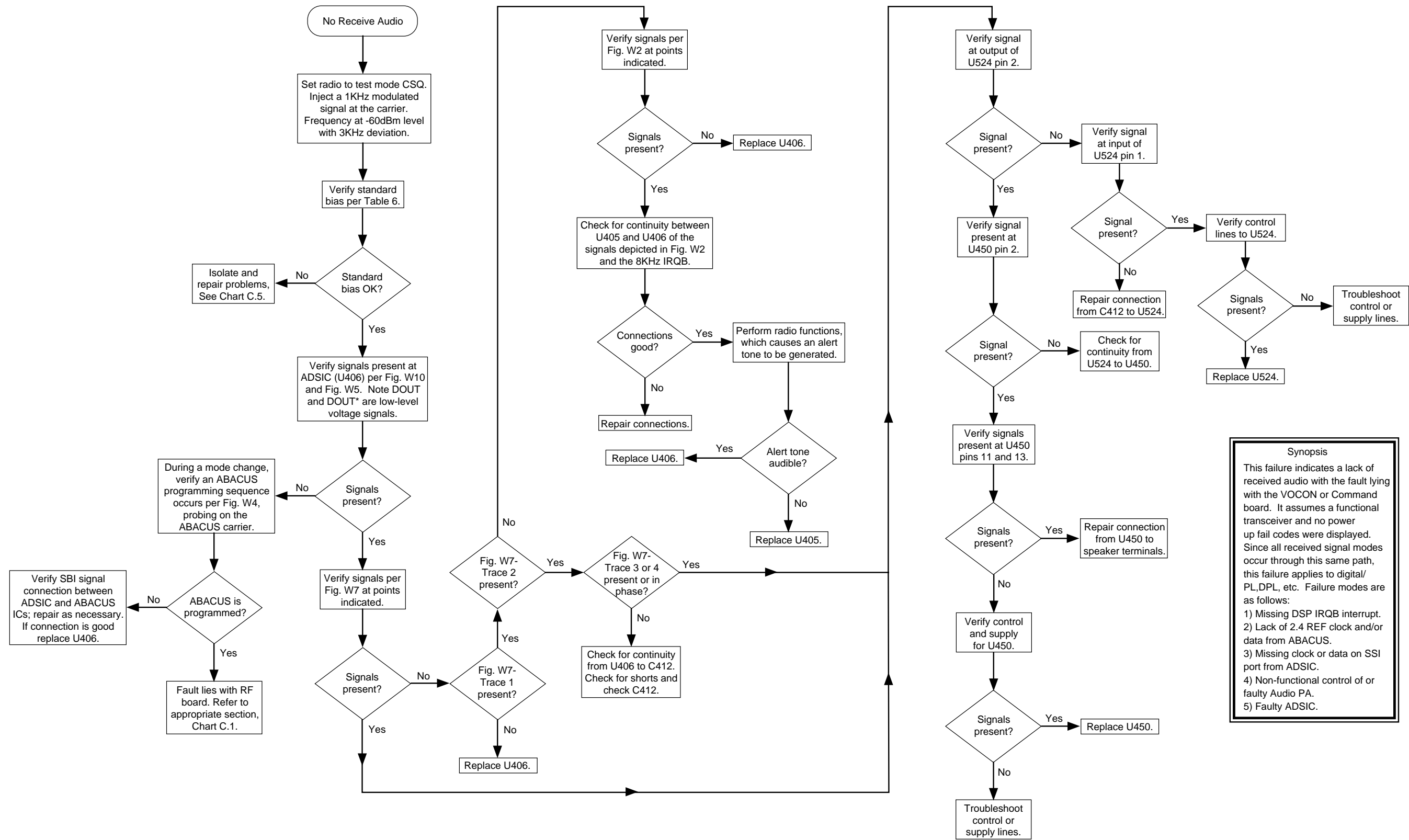

Chart C.17 09/10, Secure Hardware Failure

Chart C.18 09/90, Secure Hardware Failure



Synopsis
 This failure indicates a lack of received audio with the fault lying with the VOCON or Command board. It assumes a functional transceiver and no power up fail codes were displayed. Since all received signal modes occur through this same path, this failure applies to digital/PL,DPL, etc. Failure modes are as follows:
 1) Missing DSP IRQB interrupt.
 2) Lack of 2.4 REF clock and/or data from ABACUS.
 3) Missing clock or data on SSI port from ADSIC.
 4) Non-functional control of or faulty Audio PA.
 5) Faulty ADSIC.

Chart C.19 No RX Audio

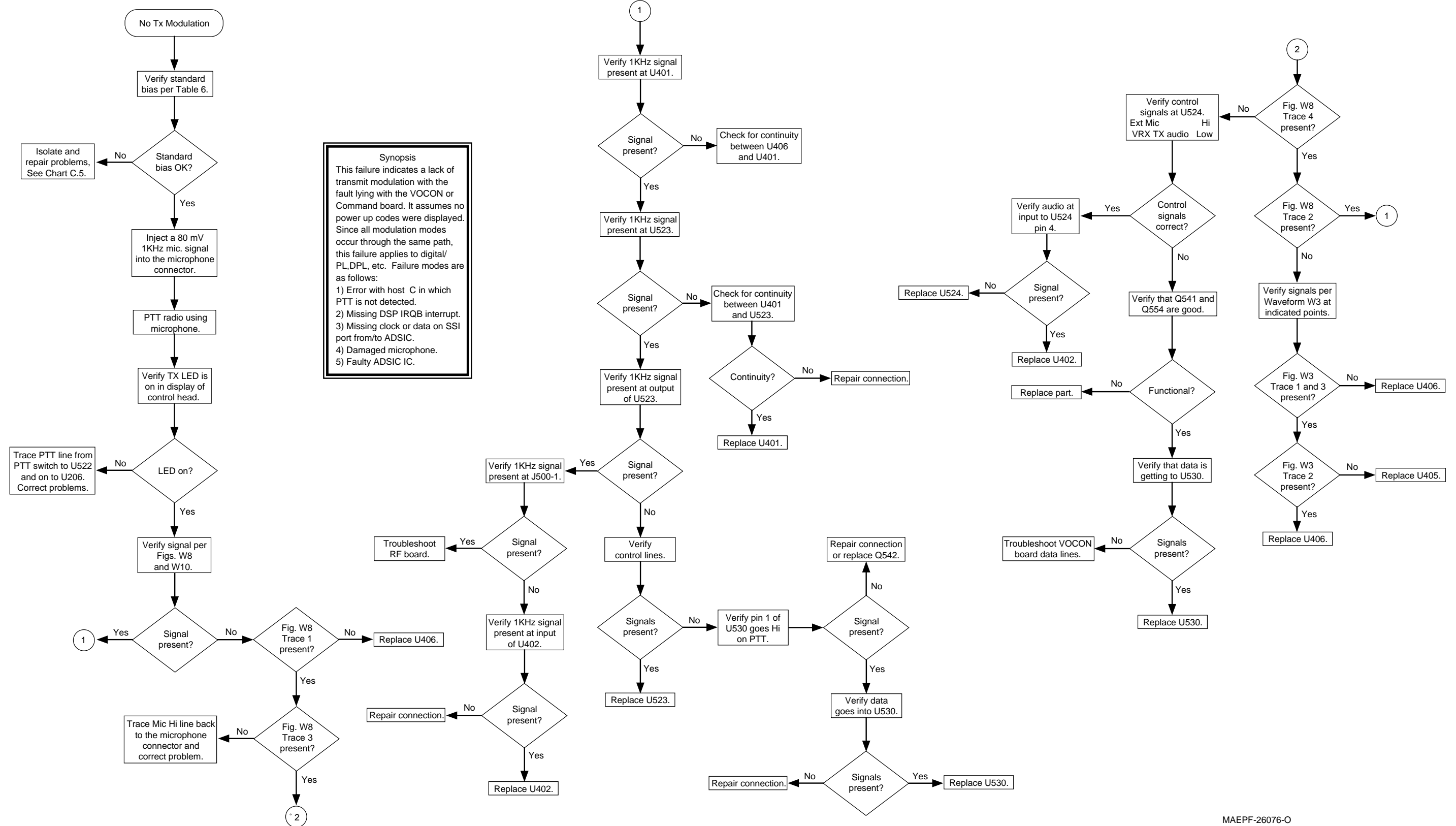

MAEPF-26076-O

Chart C.20 No TX Modulation

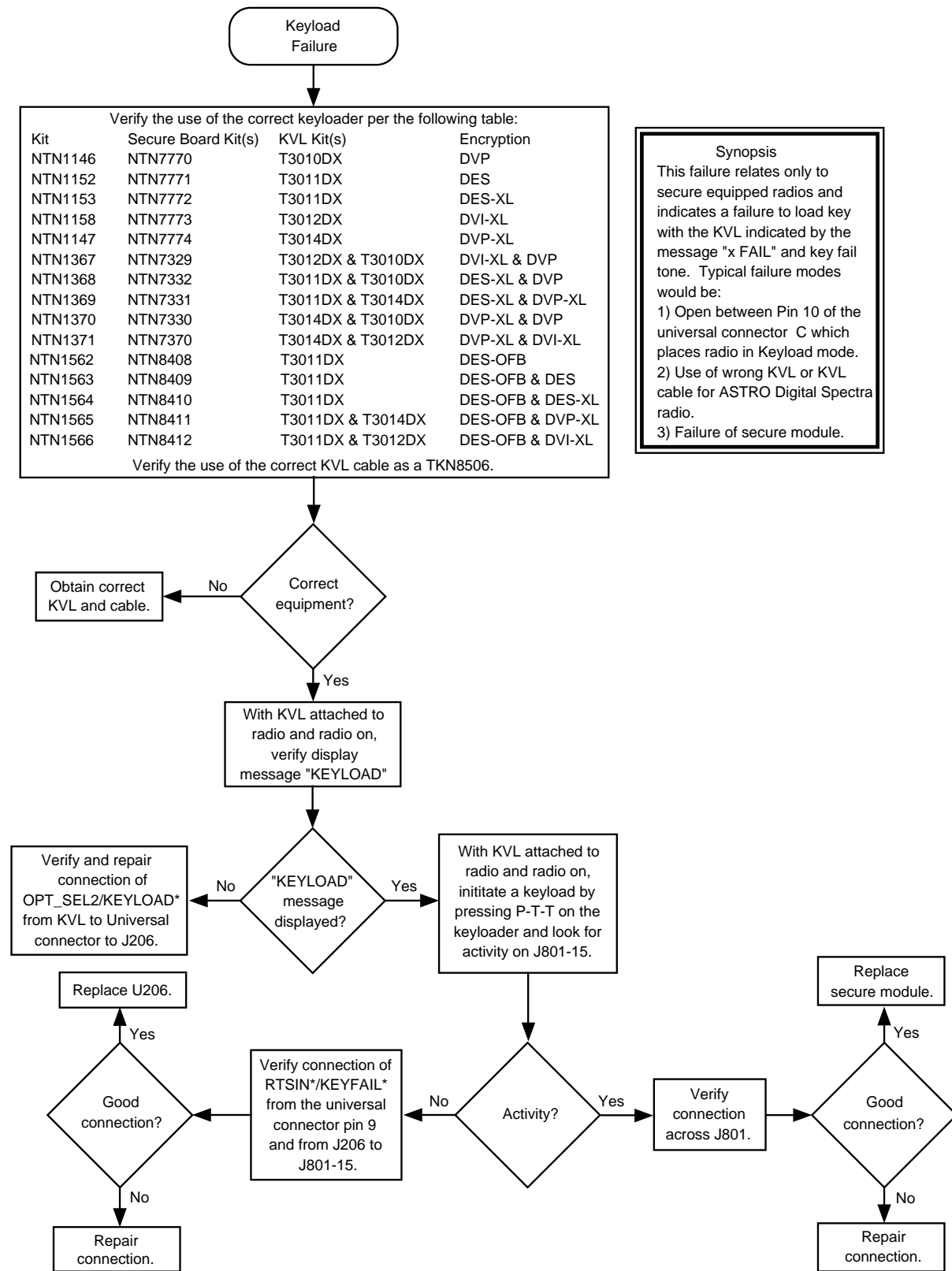

*MAEPF-24413-B

Chart C.21 Key Load Fail

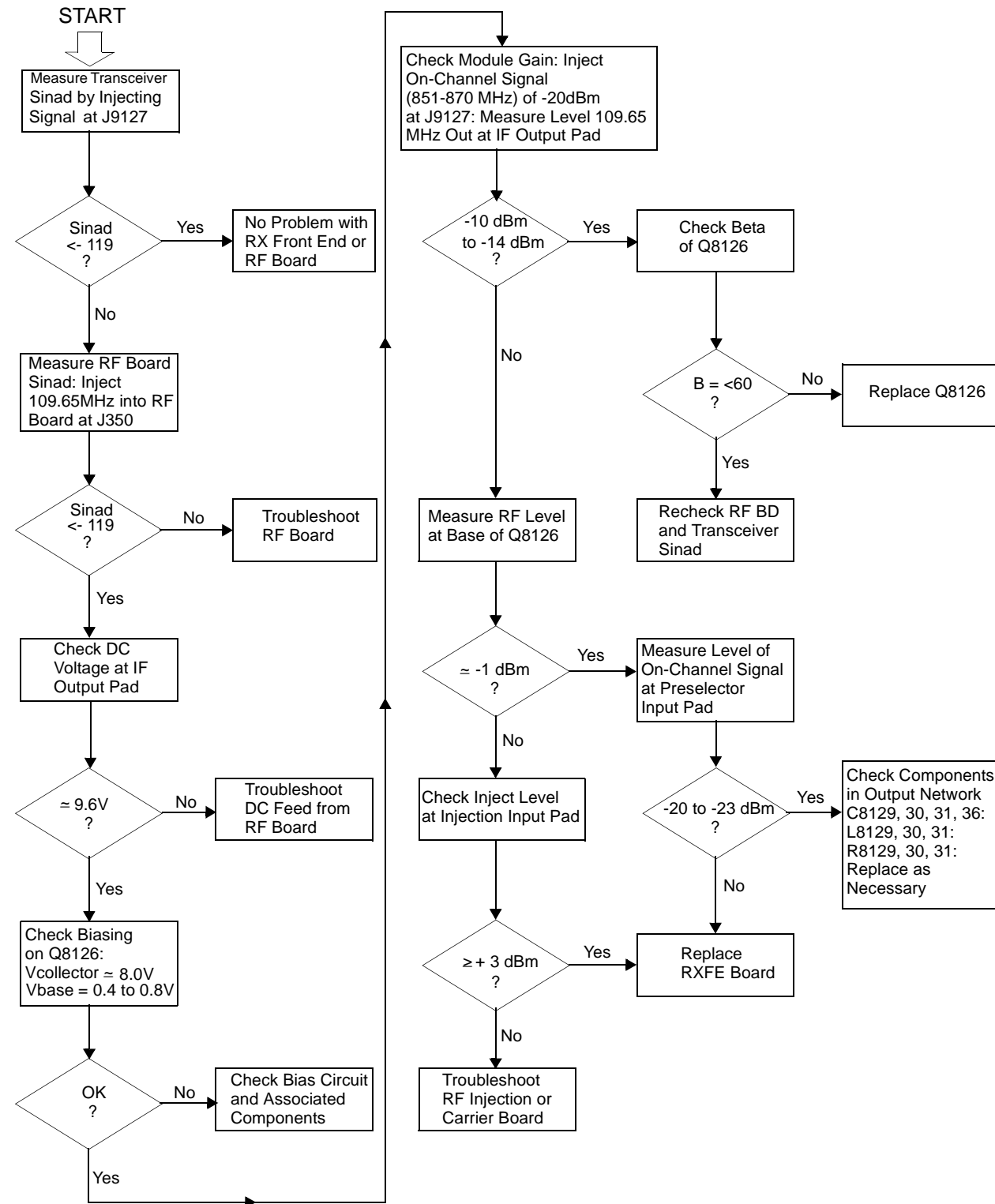

Chart C.22 800 MHz Receiver Front-End Hybrid

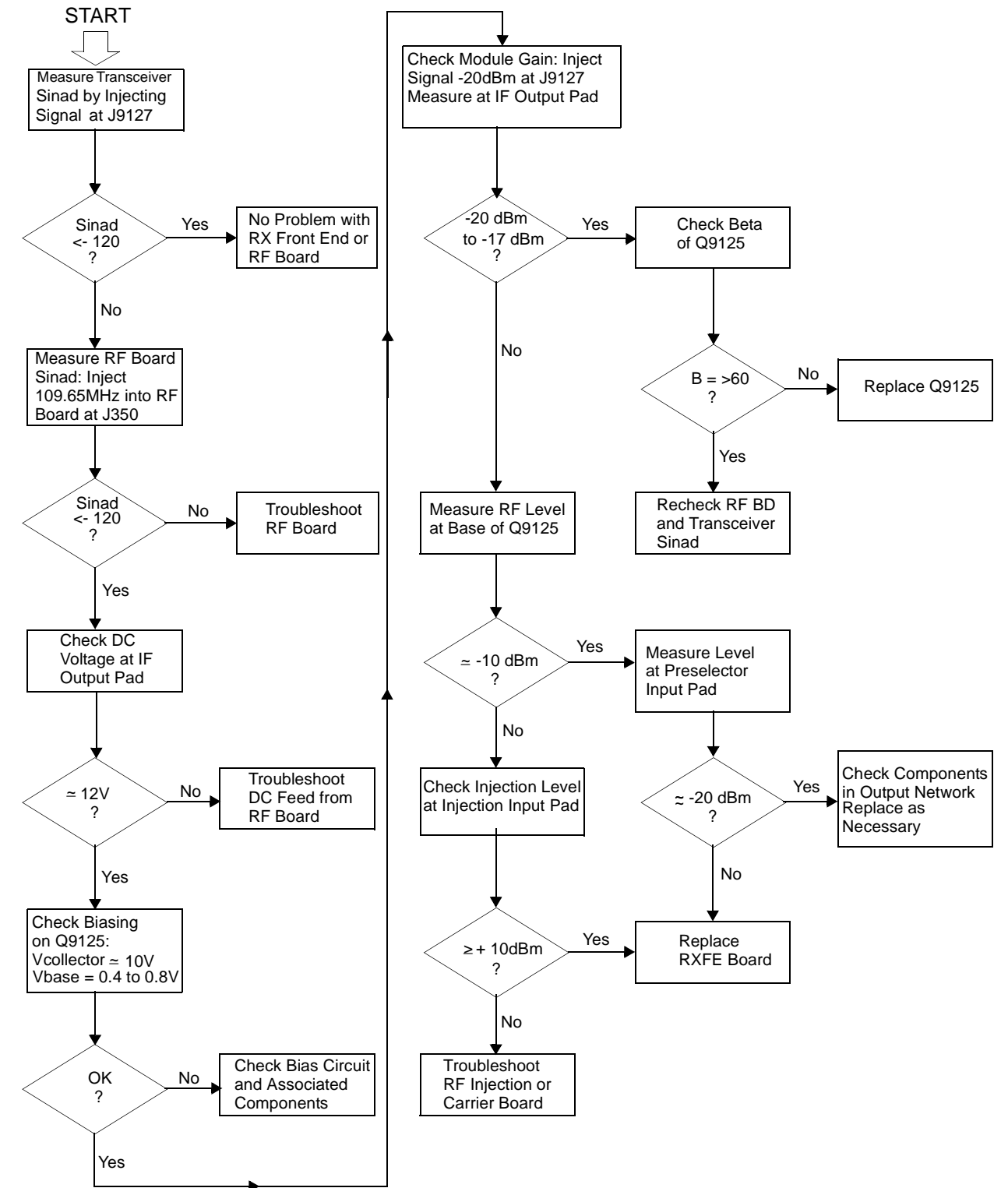

Chart C.23 UHF Receiver Front-End Hybrid

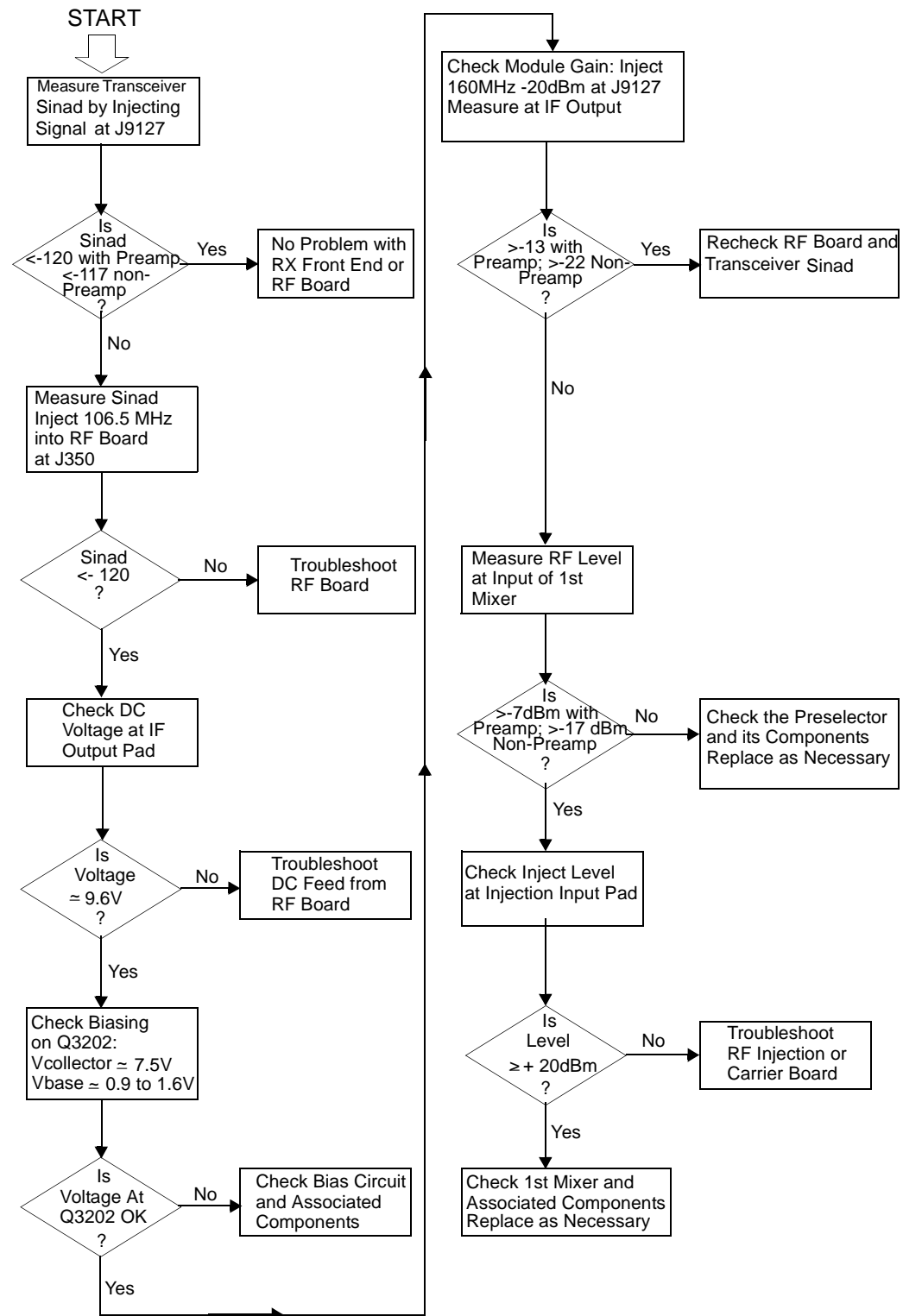

Chart C.24 VHF Receiver Front-End Hybrid

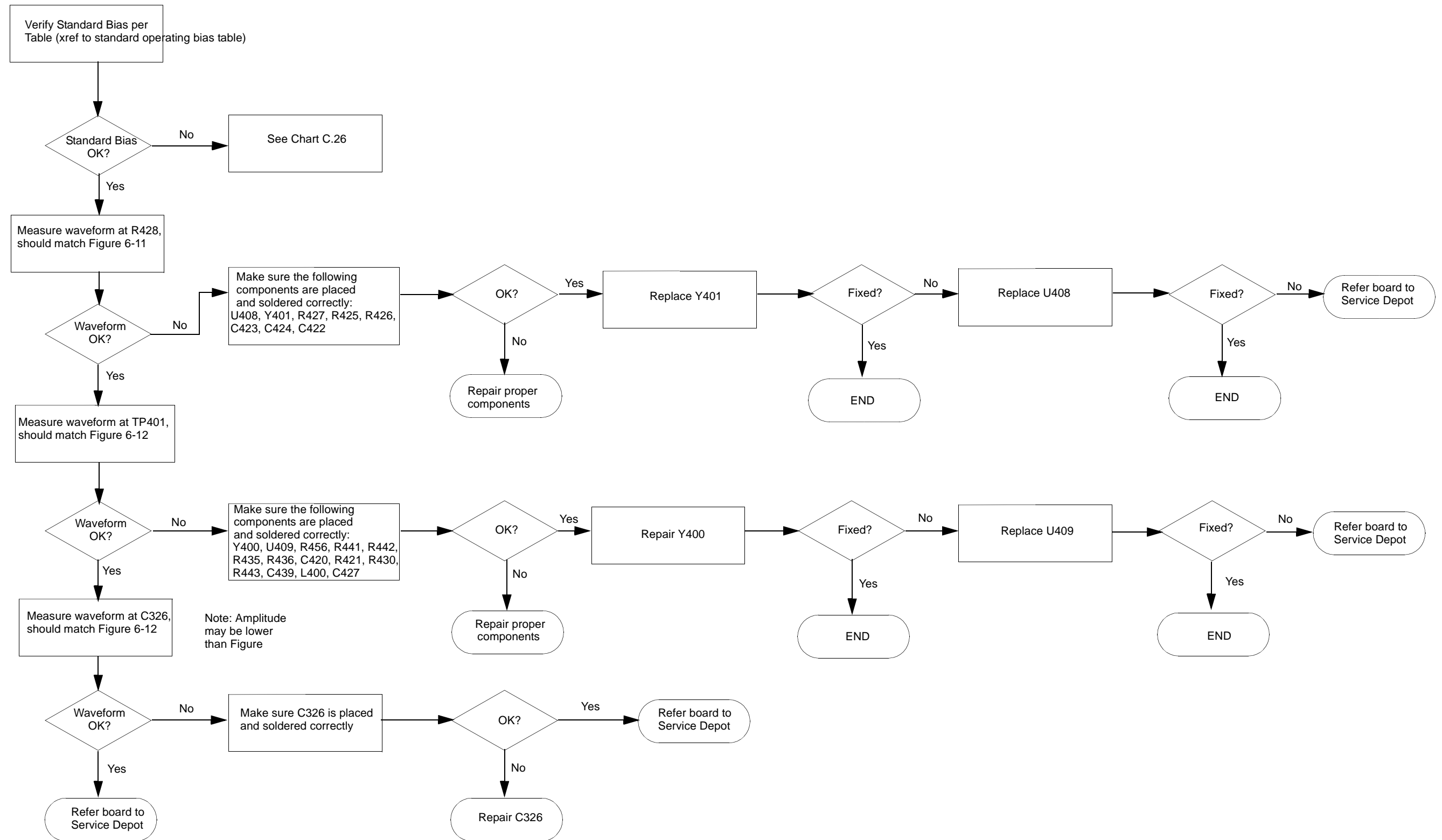

Chart C.25 ASTRO Spectra Plus VOCON Power-Up Failure

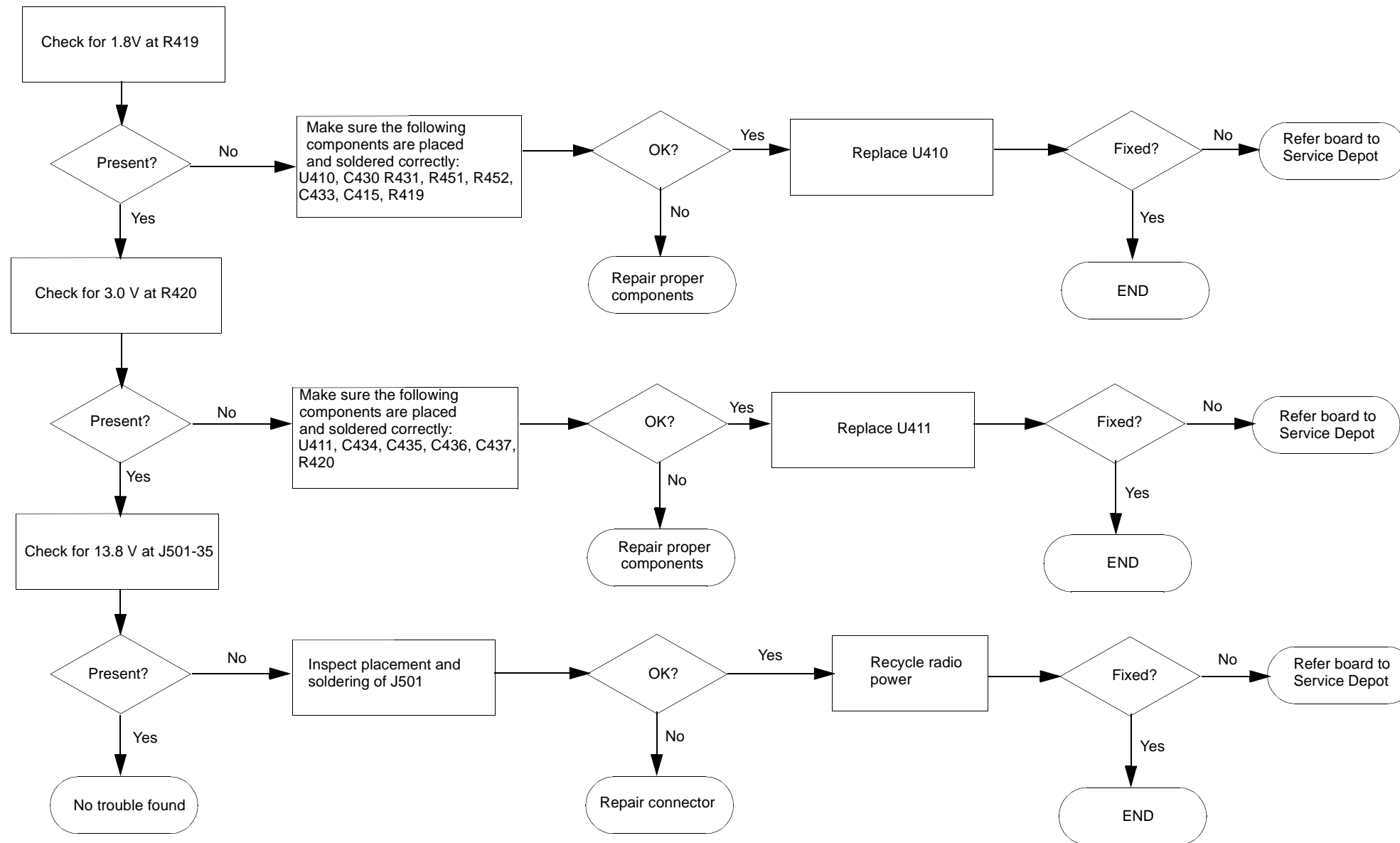

Chart C.26 ASTRO Spectra Plus VOCON DC Supply Failure

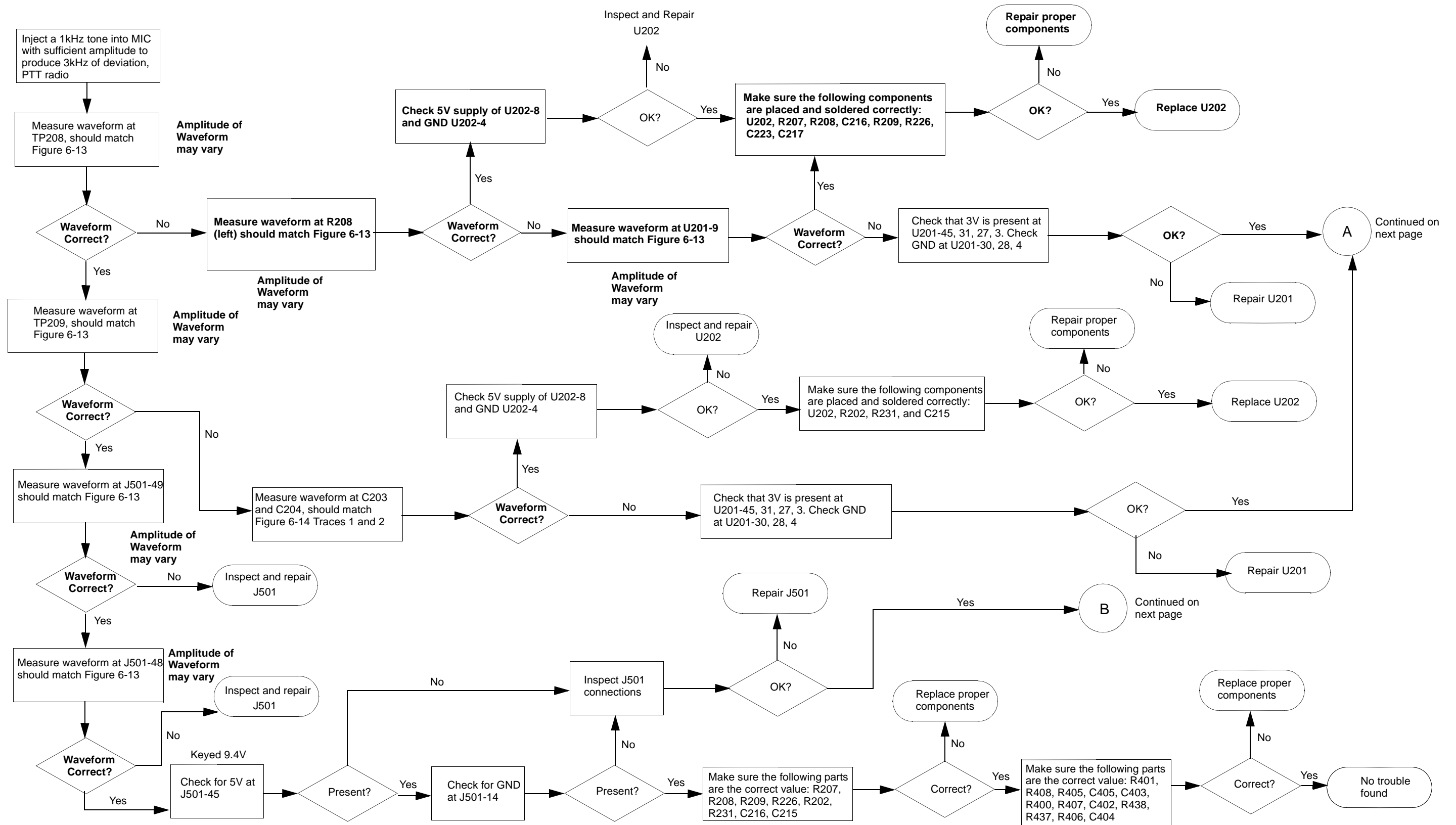

Chart C.27 ASTRO Spectra Plus VOCON TX Modulation Failure Sheet 1 of 4

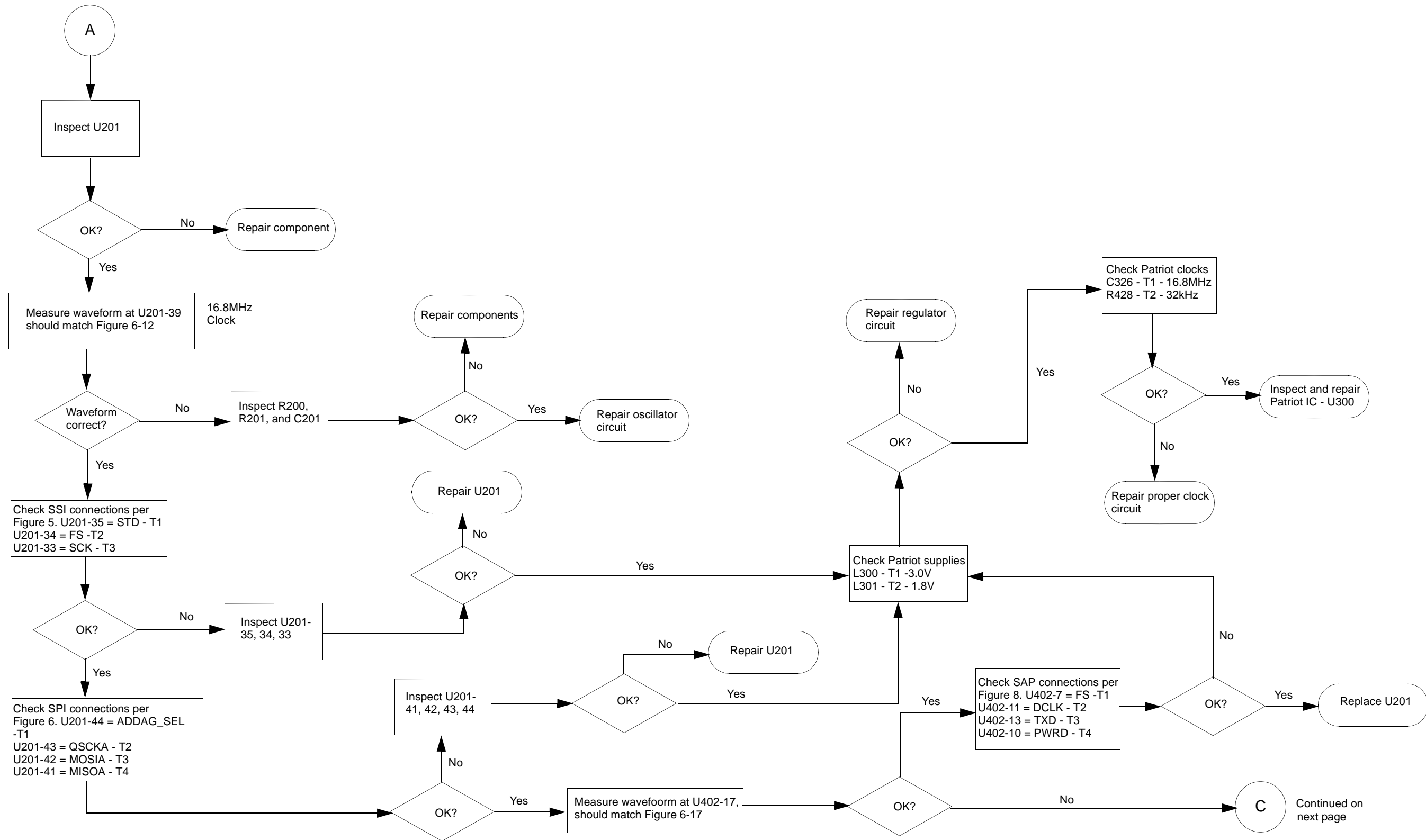

Chart C.28 ASTRO Spectra Plus VOCON TX Modulation Failure Sheet 2 of 4

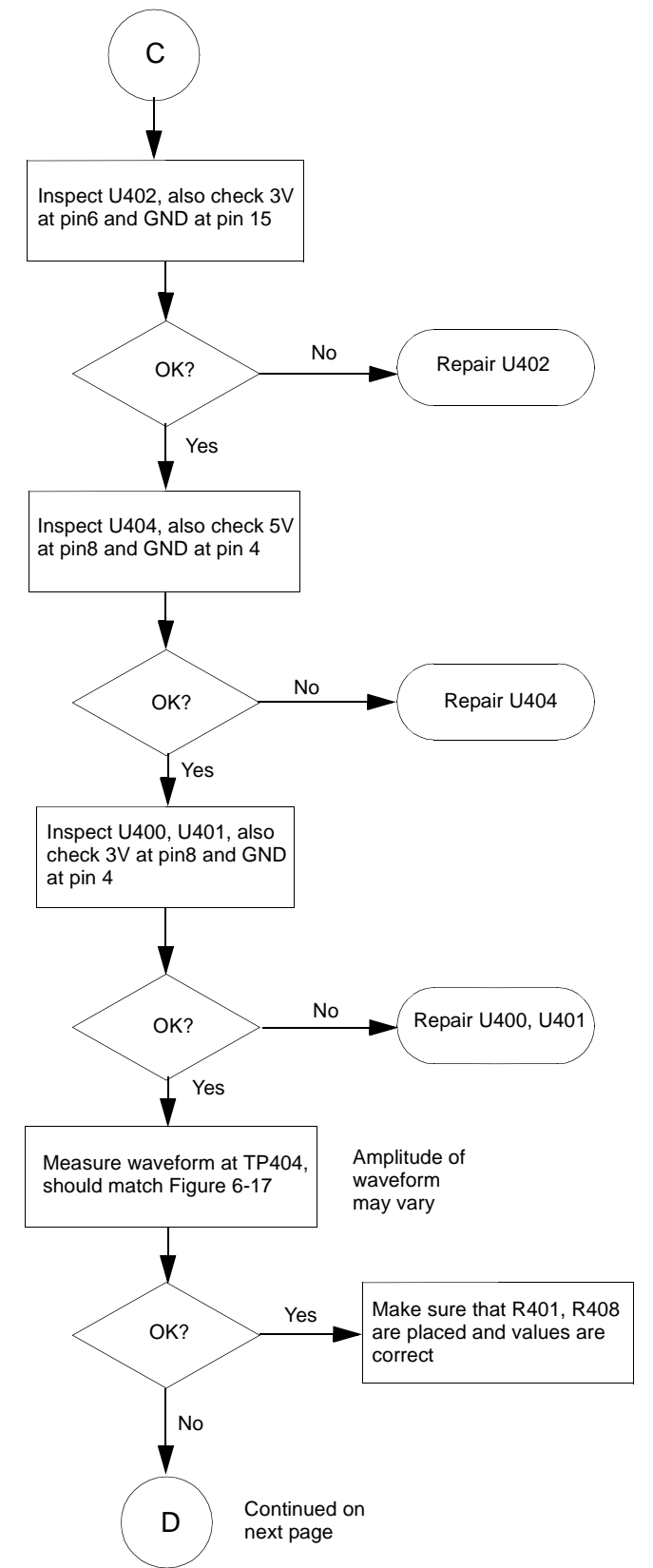
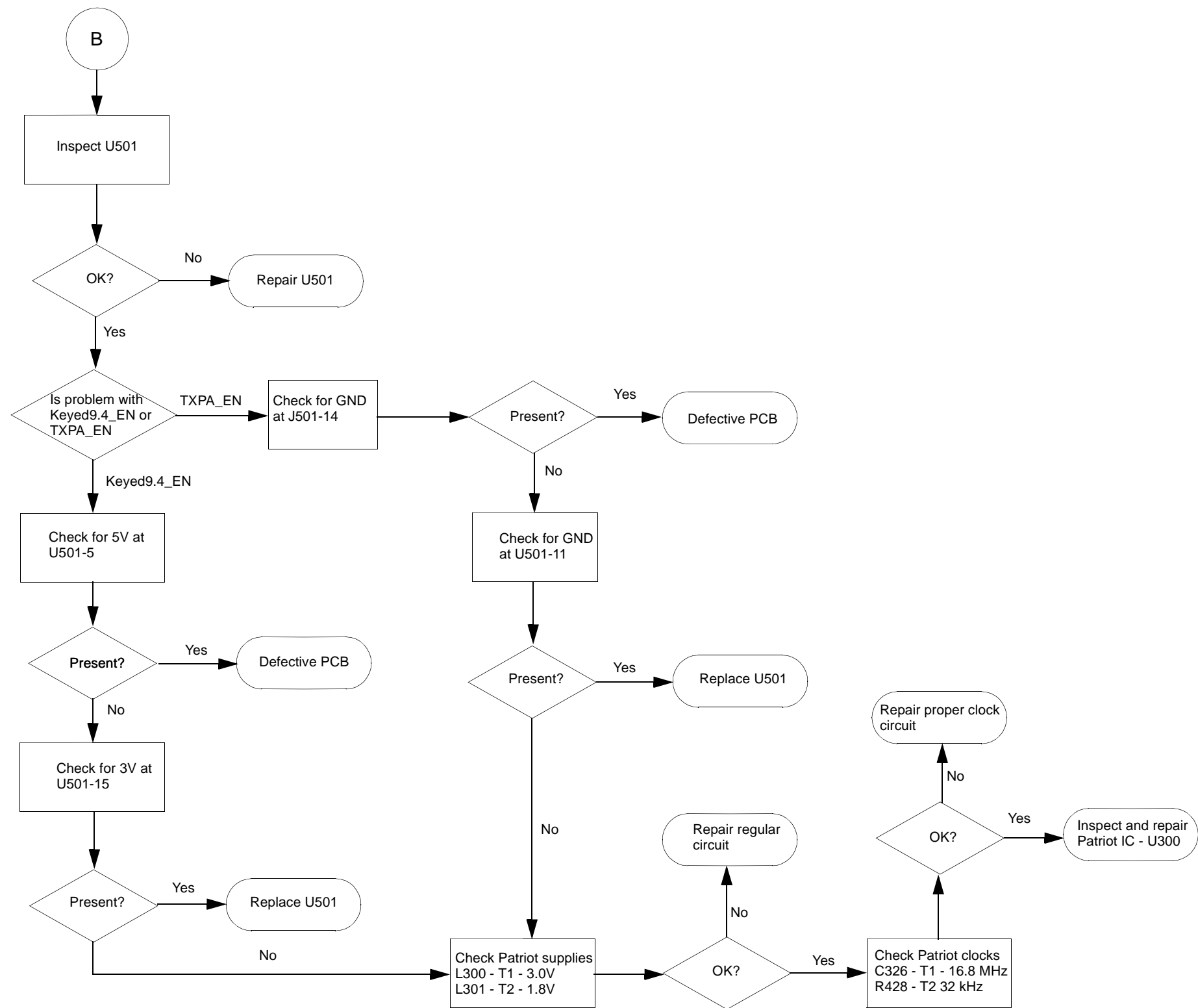

Chart C.29 ASTRO Spectra Plus VOCON TX Modulation Failure Sheet 3 of 4

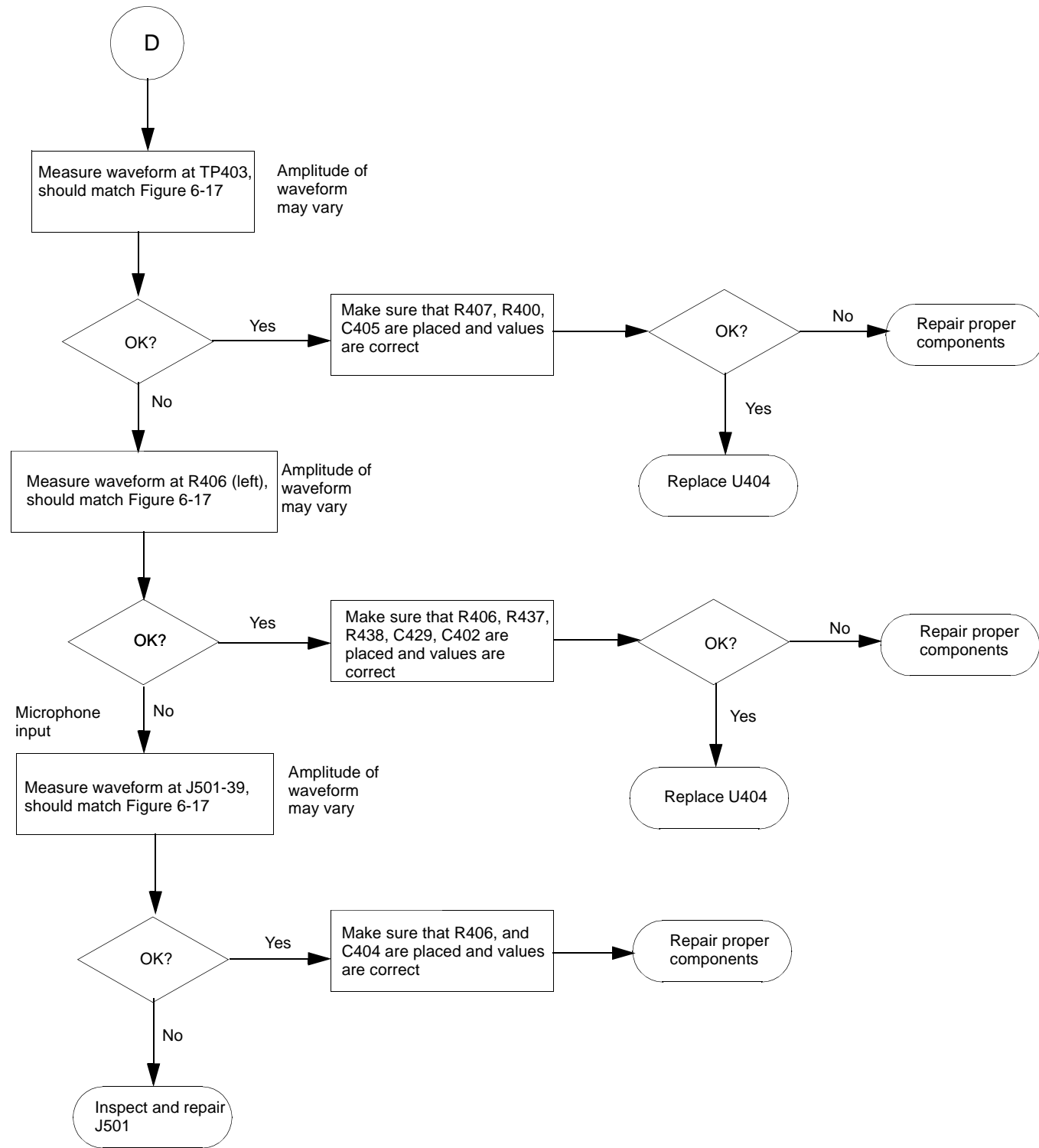

Chart C.30 ASTRO Spectra Plus VOCON TX Modulation Failure Sheet 4 of 4

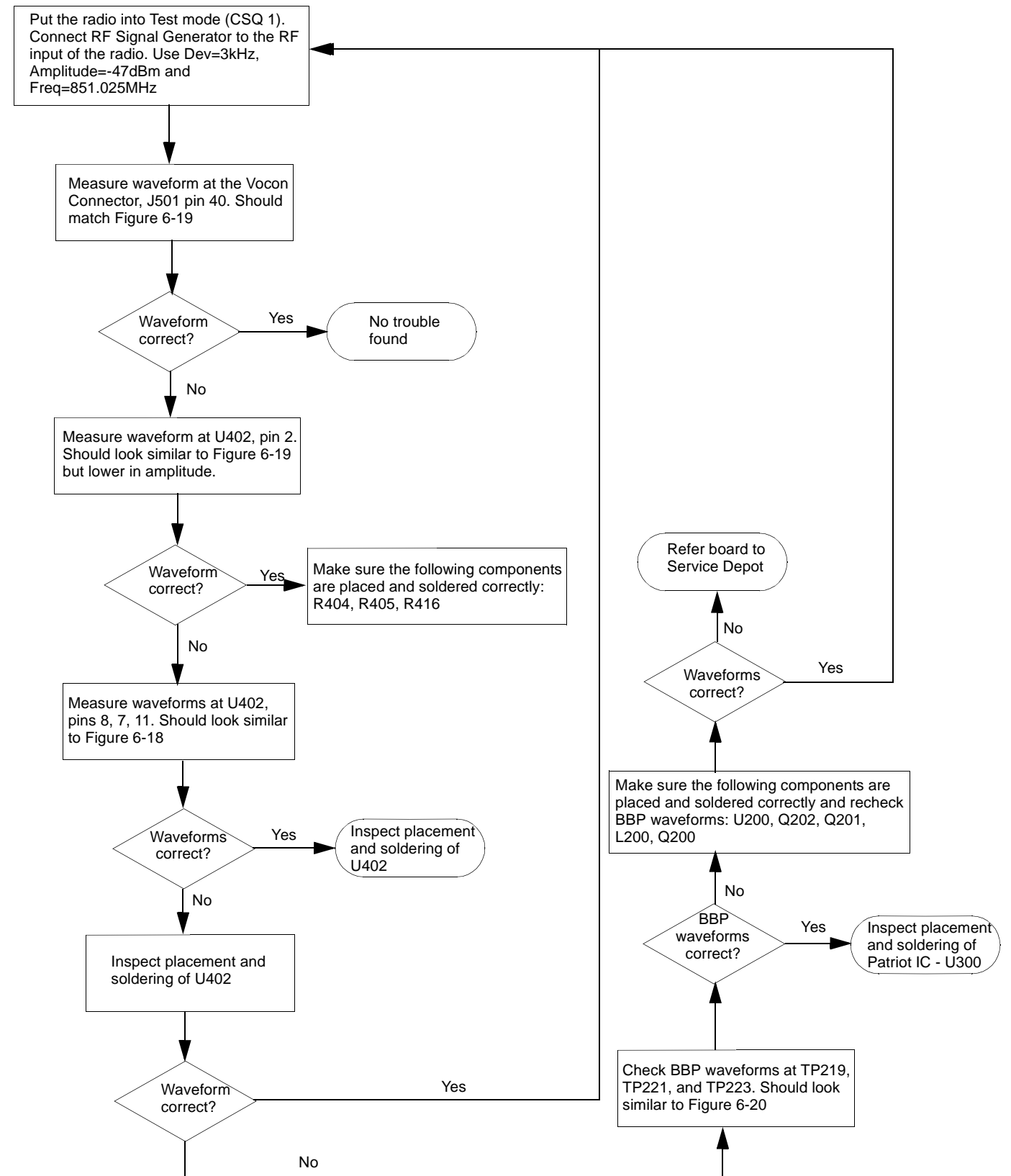

Chart C.31 ASTRO Spectra Plus VOCON RX Audio Failure

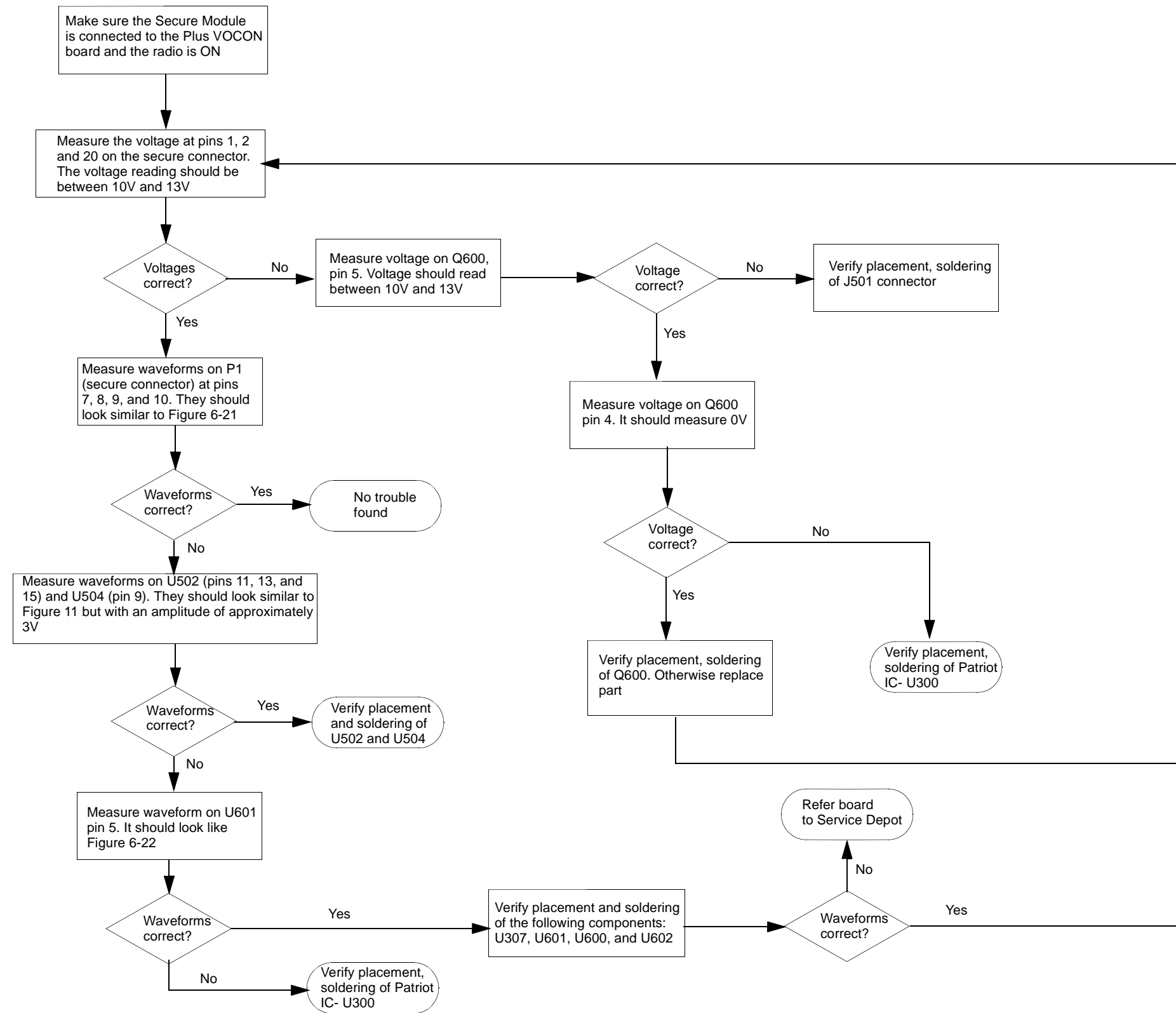
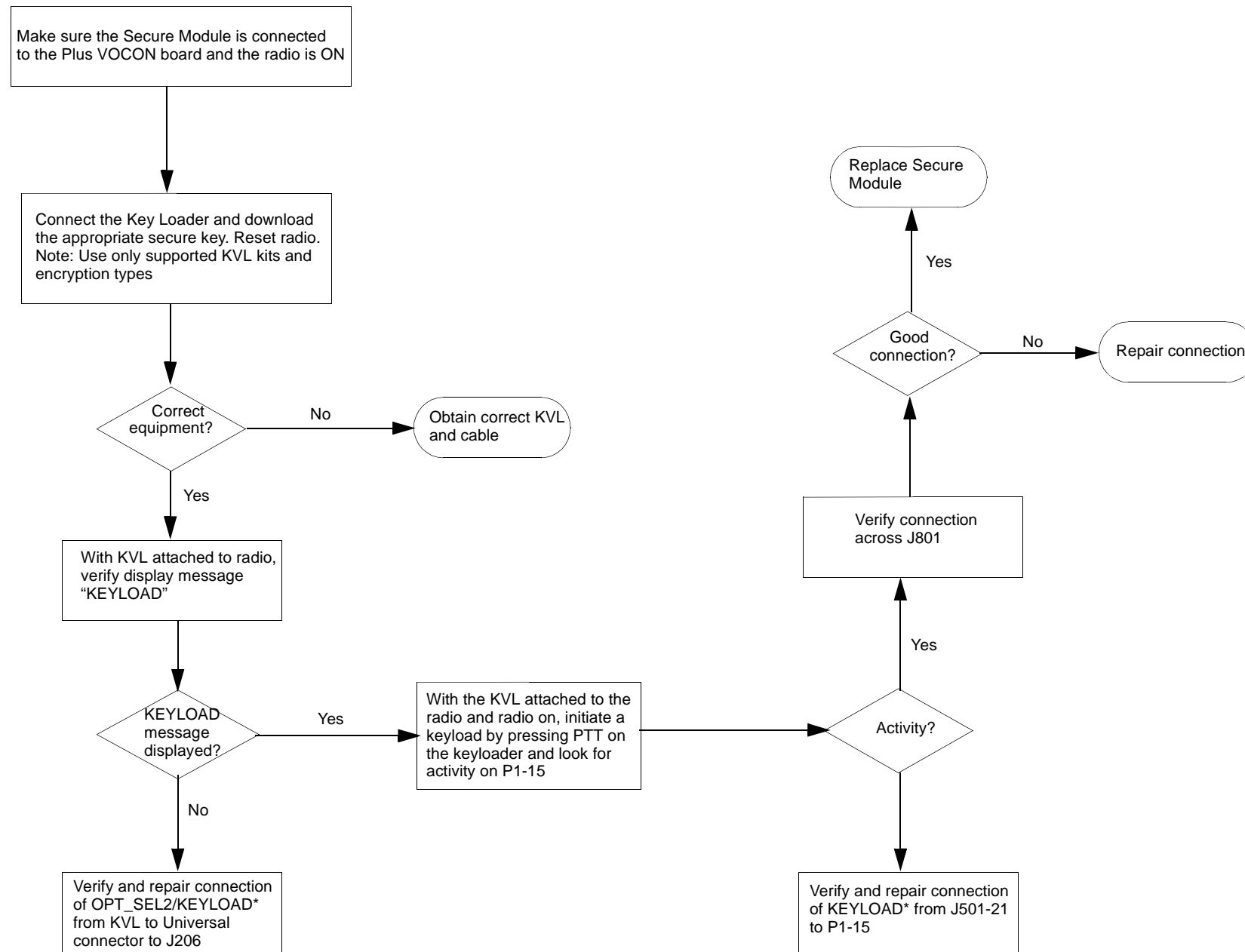

Chart C.32 ASTRO Spectra Plus VOCON Secure Hardware Failure



Synopsis

This failure relates only to secure equipped radios and indicates a failure to load a key with the KVL indicated by the message "xFail" and keyfail tone. Typical failure modes would be:

- 1) Keyload line not connected properly.
- 2) Use of wrong KVL or KVL cable.
- 3) Failure of Secure Module.

Chart C.33 ASTRO Spectra Plus VOCON Key Load Fail

Chapter 6 Troubleshooting Waveforms

6.1 Introduction

This chapter contains images of waveforms that might be useful in verifying operation of certain parts of the circuitry. These waveforms are for reference only; the actual data depicted will vary depending upon the operating conditions.

Table 6-1. List of Troubleshooting Waveforms

Waveform	Page
ASTRO Digital Spectra Waveforms	
Waveform W1: Power-On Reset Timing	6-2
Waveform W2: DSP SSI Port RX Mode	6-2
Waveform W3: DSP SSI Port TX Mode CSQ	6-3
Waveform W4: ABACUS Programming at Mode Change	6-3
Waveform W5: ABACUS/ADSIC Interface	6-4
Waveform W6: SPI Bus Programming ADSIC	6-4
Waveform W7: Receive Audio	6-5
Waveform W8: Transmit Audio	6-5
Waveform W9: Power-Down Reset	6-6
Waveform W10: ADSIC 2.4 MHz Reference	6-6
ASTRO Digital Spectra Plus VOCON Waveforms	
32 kHz Clock Waveform	6-7
16.8 MHz Clock Waveform	6-8
TX Modulation Out Waveform	6-8
Differential ADDAG Output Waveform	6-9
TX SSI Waveform	6-9
SPI Bus Waveform	6-10
TX 1 kHz Tone Waveform	6-10
Serial Audio Port Waveform	6-11
RX Audio Waveform	6-11
RX BBP Waveform	6-12
Secure Interface Waveform	6-12
8 kHz Frame Sync for Security Circuitry Waveform	6-13

6.2 ASTRO Digital Spectra Waveforms

Waveform W1: Power-On Reset Timing

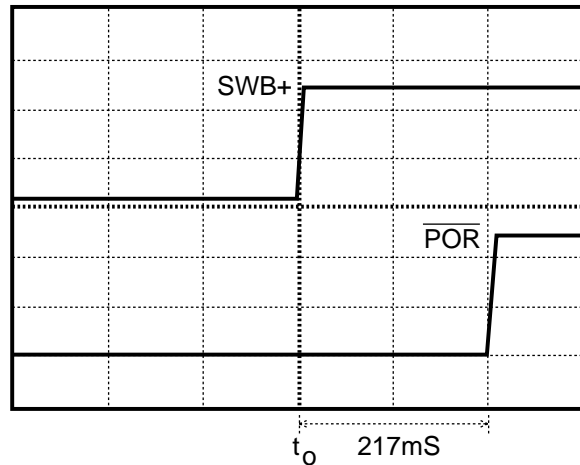

MAEPF-25187-O

Waveform W2: DSP SSI Port RX Mode

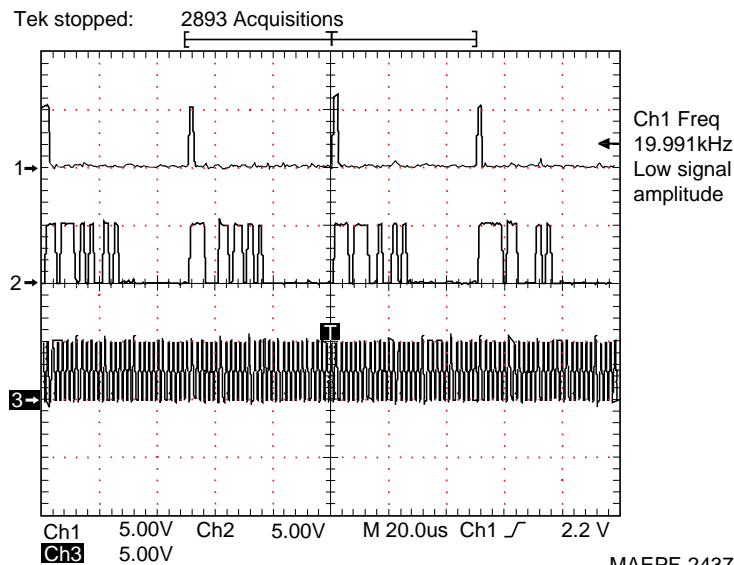

MAEPF-24377-O

W2: DSP SSI Port RX mode.
 Receiving
 1KHz tone @ 3KHz deviation, -60dBm.
 Trace 1 - RFS
 Trace 2 - RXD
 Trace 3 - SCKR (2.4/0.600MHz)

Note 1: Typically SCKR is a 2.4 MHz clock. In low power modes, as shown here, SCKR is 600KHz.

Waveform W3: DSP SSI Port TX Mode CSQ

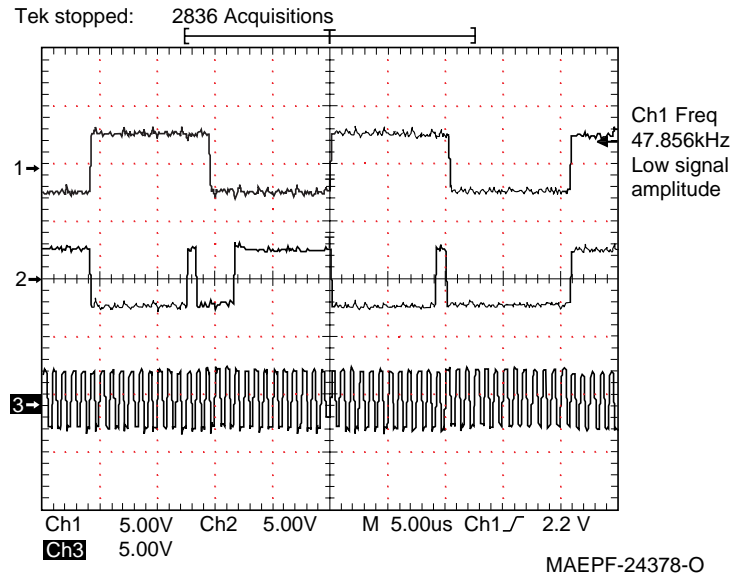

W3: DSP SSI Port TX mode CSQ.
Trace 1 - SC2
Trace 2 - STD
Trace 3 - SCK (1.2MHz)

Waveform W4: ABACUS Programming at Mode Change

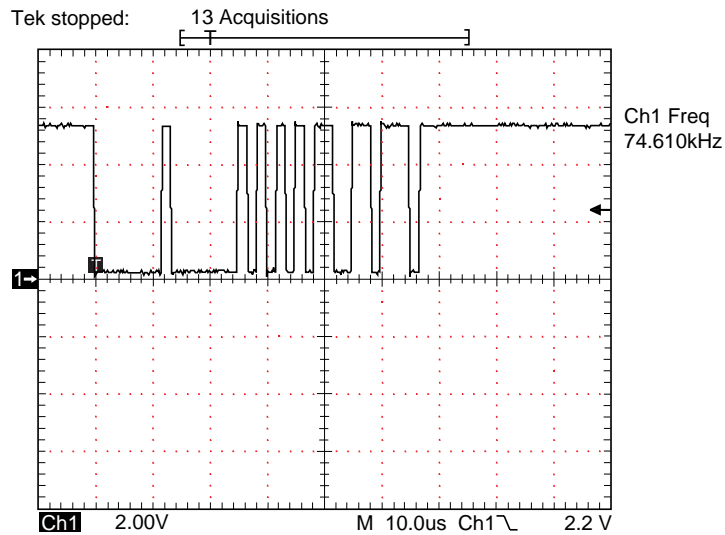

W4: ABACUS programming captured during mode change.
Trace 1 - (ADSIC) SBI

Waveform W5: ABACUS/ADSIC Interface

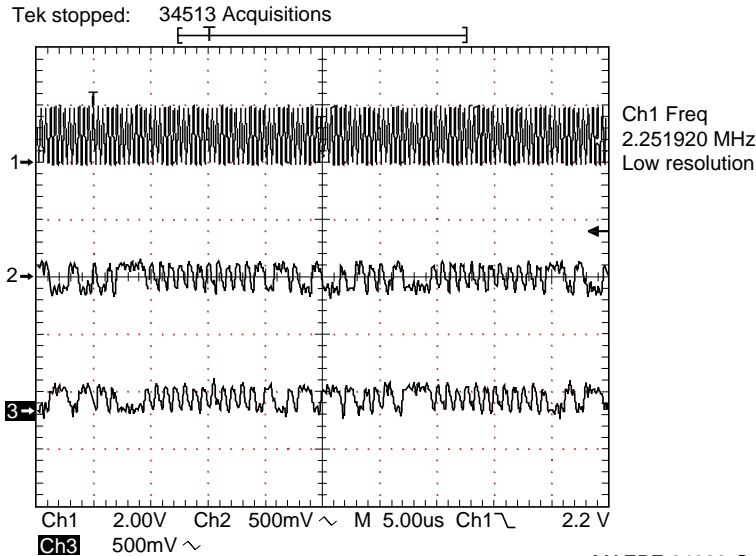

MAEPF-24380-O

W5: ABACUS/ADSIC Interface.
 Receiving 1KHz tone @ 3KHz deviation,
 -60dbm.
 Trace 1 -IDC (2.4MHz)
 Trace 2 - DOUT²
 TRACE 3 - DOUT*

Note 2: Since these signals are a differential current loop these voltages are very low.

Waveform W6: SPI Bus Programming ADSIC

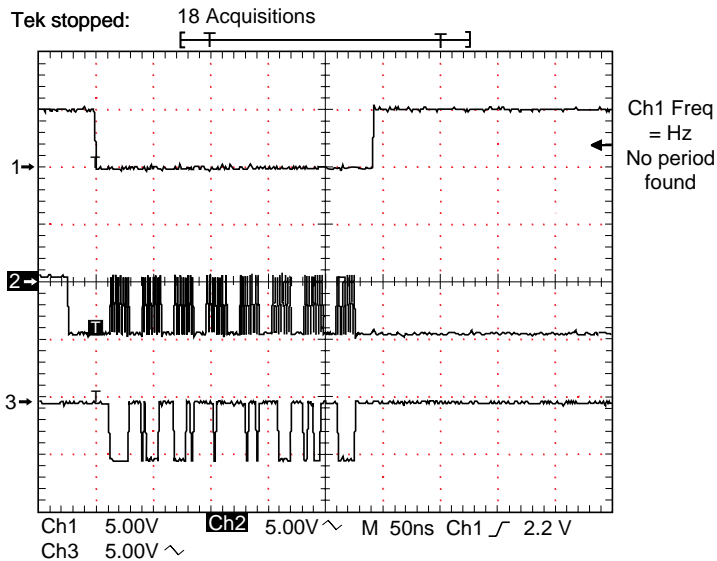

MAEPF-24381-O

W6: SPI Bus Programming ADSIC.
 Trace 1 - ADSIC_SEL*
 Trace 2 - SPI_SCK
 Trace 3 - MOSI
 Note: These waveforms are typical to any device on the SPI bus.

Waveform W7: Receive Audio

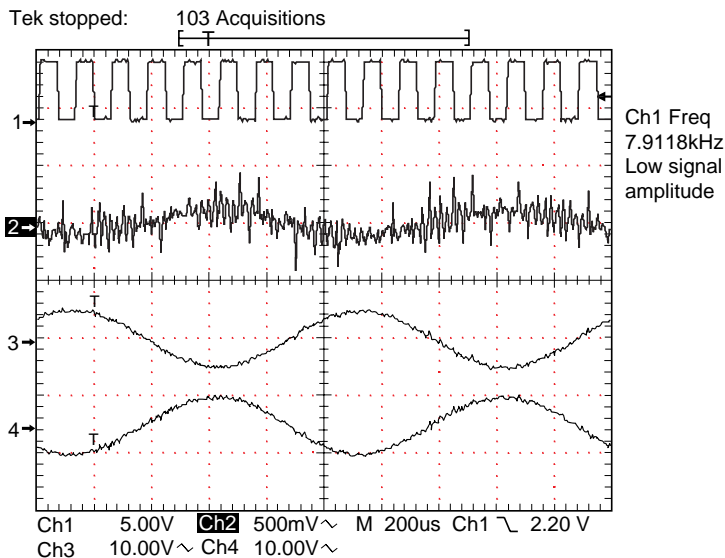

W7: Receive audio: Receiving
 1KHz tone @ 3KHz deviation, -60dBm. Volume set to rated audio.
 Trace 1 - IRQB @ DSP (8KHz)
 Trace 2 - SD0 @ C412 on Command Board
 Trace 3 - SPKR_LOW Out of U450
 Trace 4 - SPKR_HI Out of U450³

Note 3: Actual level is dependent upon volume setting.

MAEPF-26077-O

Waveform W8: Transmit Audio

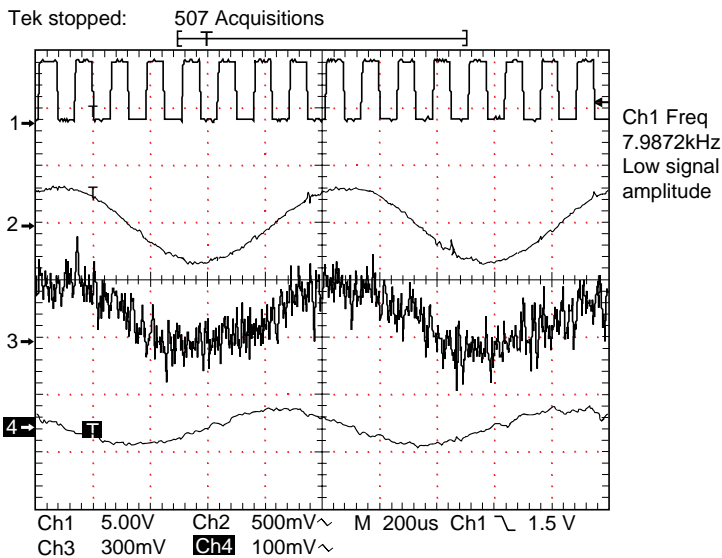

W8: Transmit Audio. 1KHz Tone
 which provides 3KHz deviation.
 Trace 1 - IRQB @ DSP (8KHz)
 Trace 2 - MODIN
 Trace 3 - MIC @ node P502/R415
 Trace 4 - MAI @ U406

MAEPF-26078-O

Waveform W9: Power-Down Reset

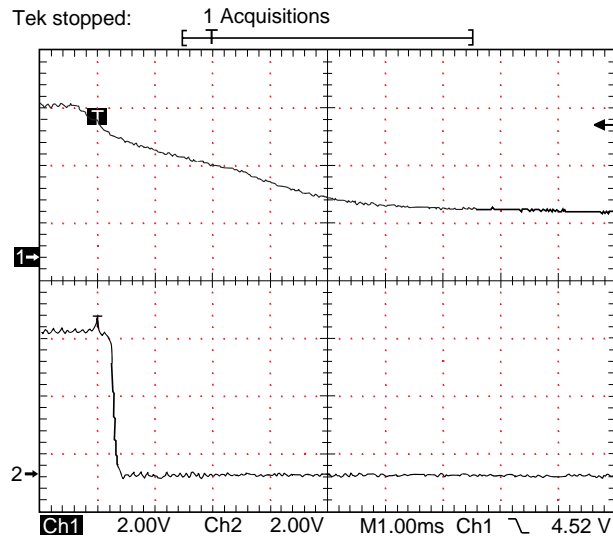

W9: Power Down Reset. MAEPF-24384-O
Trace 1 - +5V @ U407 (VDD)
Trace 2 - Reset @ U407 (OUT)

Waveform W10: ADSIC 2.4 MHz Reference

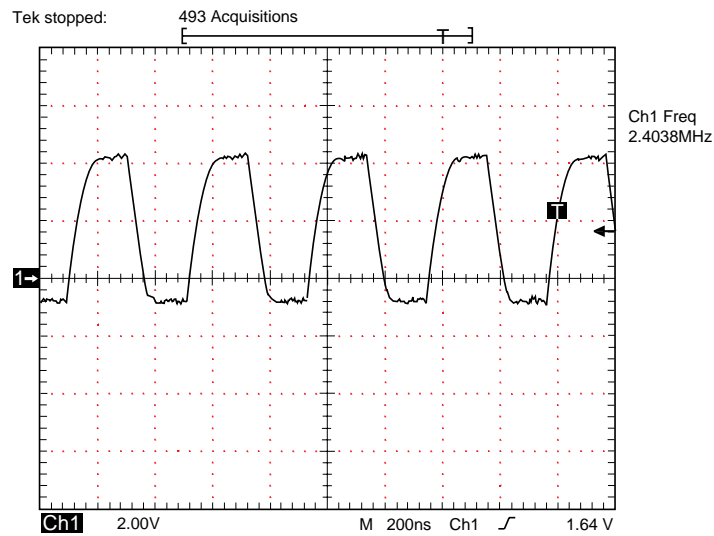

W10 ADSIC 2.4 MHz Reference MAEPF-24385-O
Trace 1 - IDC @ U406

6.3 ASTRO Digital Spectra Plus VOCON Board Waveforms

This section contains images of waveforms specific to the ASTRO Digital Spectra Plus VOCON board. These waveforms might be useful in verifying operation of certain parts of the circuitry. These waveforms are for reference only; the actual data depicted will vary depending upon the operating conditions.

32 kHz Clock Waveform

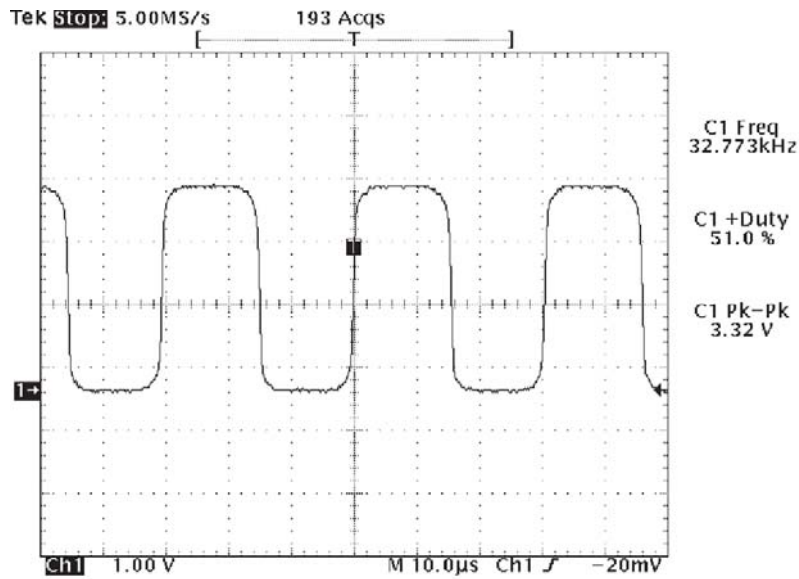

Trace 1 — R428 — 32 kHz Clock

16.8 MHz Clock Waveform

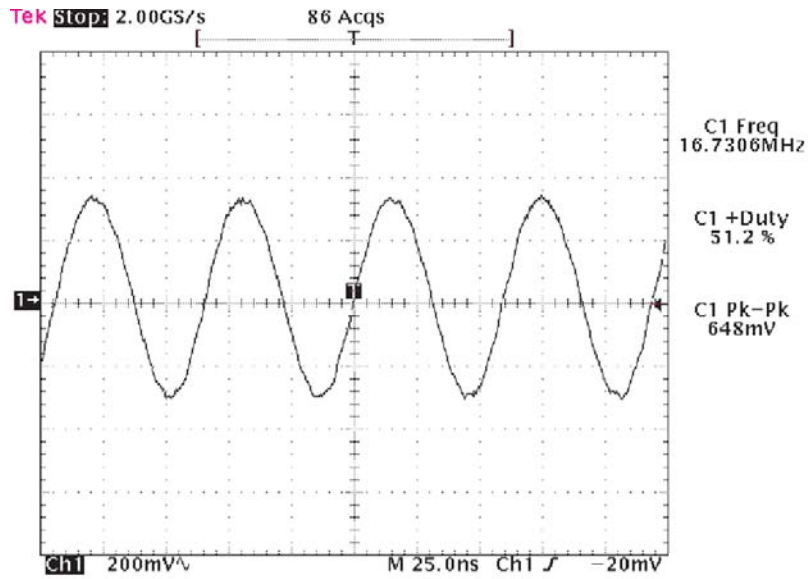

Trace 1 — TP401 — 16.8 MHz Clock

TX Modulation Out Waveform

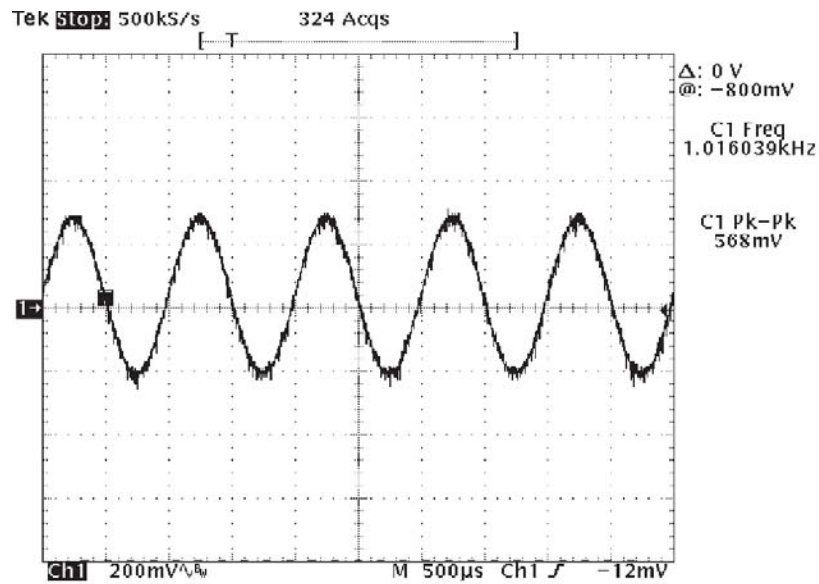

Transmitting
1 kHz tone at 85mVrms into microphone
Trace 1 — U201 — 9

Differential ADDAG Output Waveform

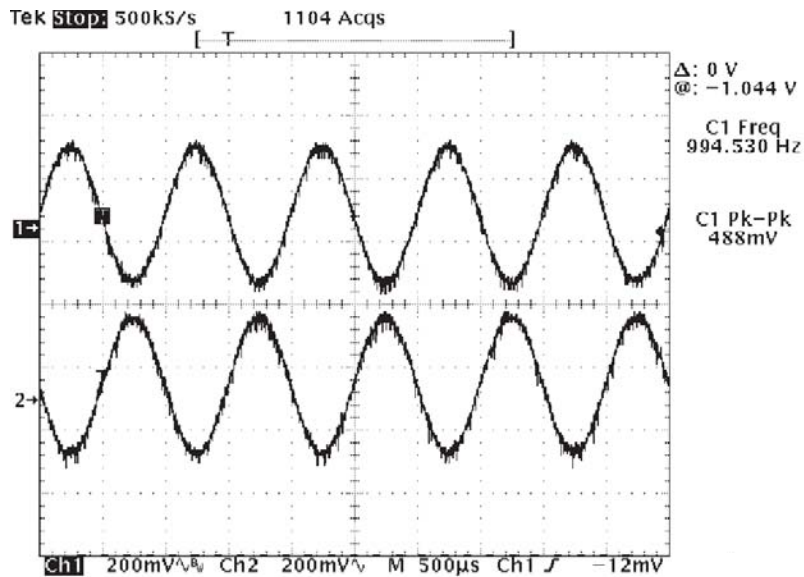

Transmitting
 1 kHz tone at 85mVrms into microphone
 Trace 1 — U201 — 4
 Trace 2 — U201 — 5

TX SSI Waveform

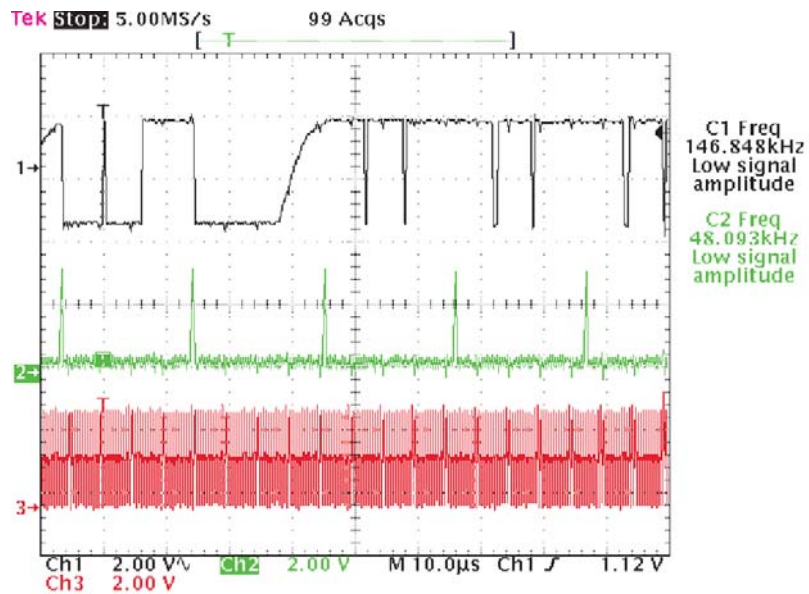

Transmitting
 1 kHz tone at 85mVrms into microphone
 Trace 1 — U201 — 33 - Data
 Trace 2 — U201 — 35 - Frame Sync
 Trace 3 — U201 — 34 - Clock

SPI Bus Waveform

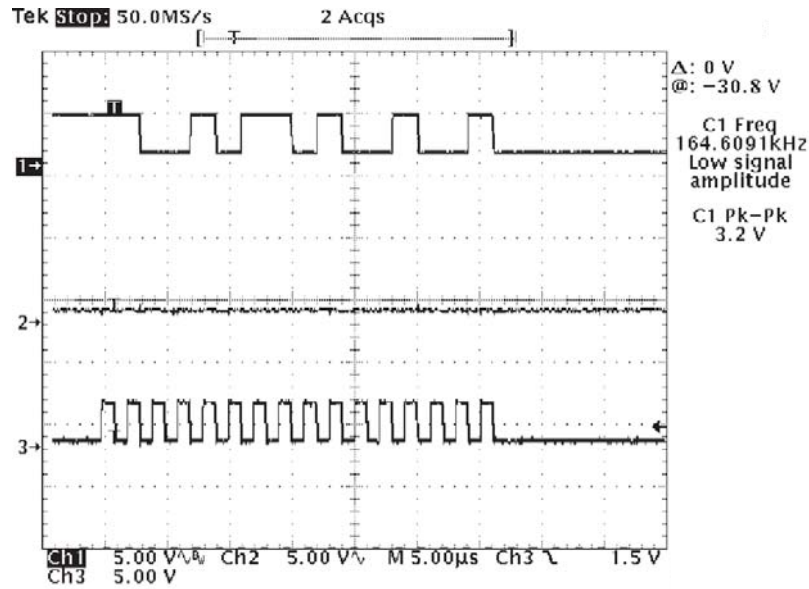

Radio Power Up
Trace 1 — U201 — 41 - Data
Trace 2 — U201 — 43 - Chip Select
Trace 3 — U201 — 42 - Clock

TX 1 kHz Tone Waveform

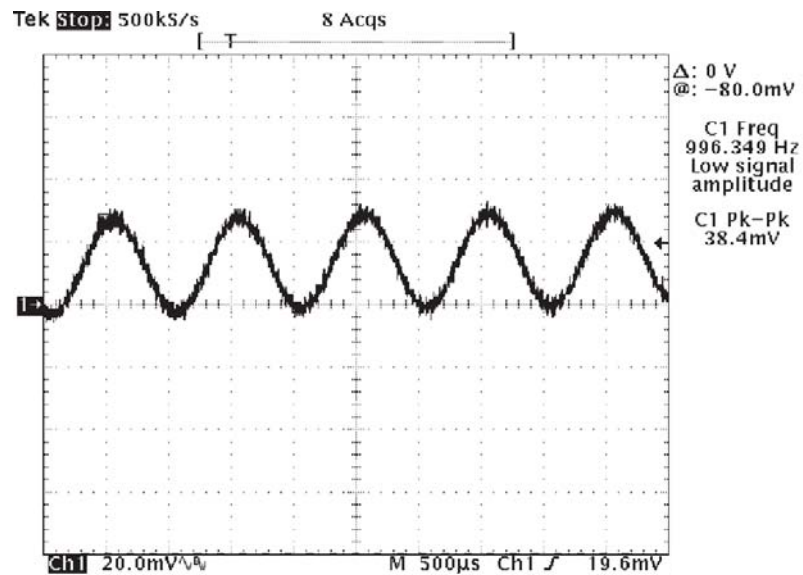

Transmitting
1 kHz tone at 85mVrms into microphone
Trace 1 — U402 — 17

Serial Audio Port Waveform

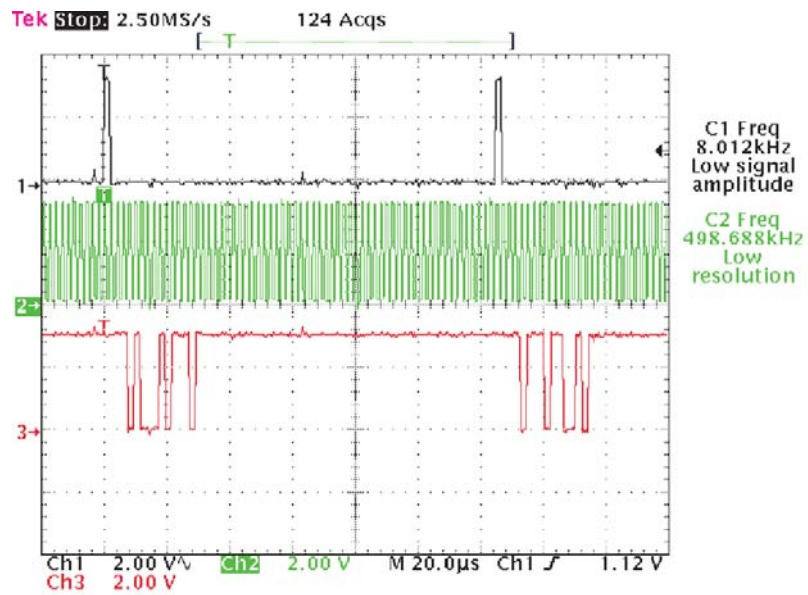

Transmitting
 1 kHz tone at 85mVrms into microphone
 Trace 1 — U402 — 7 - Frame Sync
 Trace 2 — U402 — 11 - Clock
 Trace 3 — U402 — 13 - Data

RX Audio Waveform

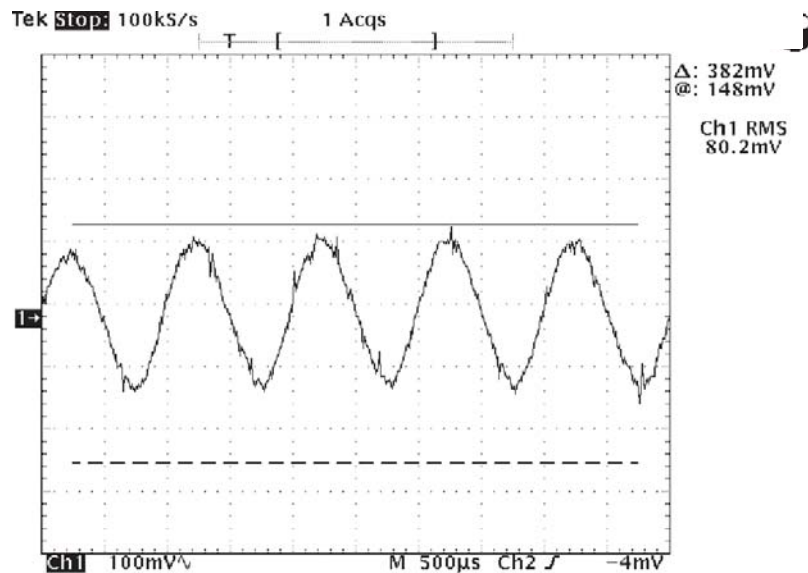

Receiving
 1 kHz tone at 3 kHz Dev, -47dBm
 Trace 1 — U402 — 2

RX BBP Waveform

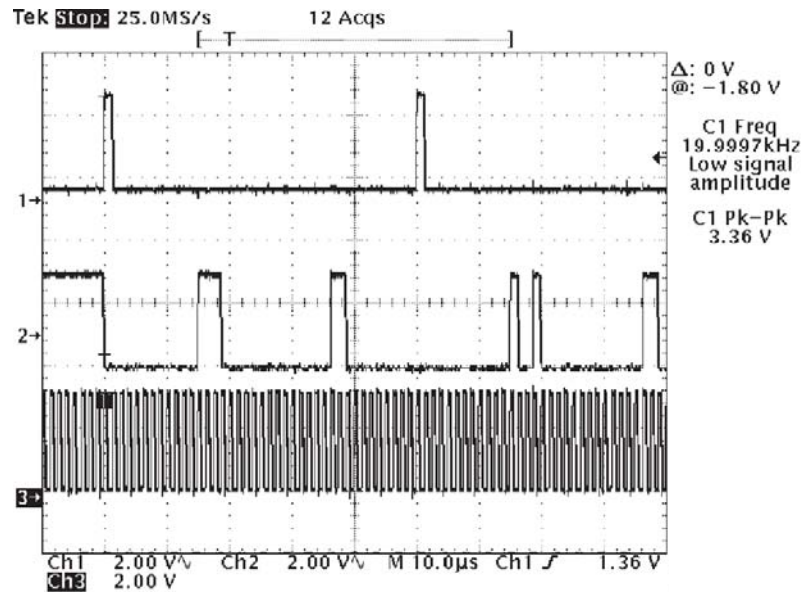

Receiving
 1 kHz tone at 3 kHz Dev, -47dBm
 Trace 1 — TP221 — Frame Sync
 Trace 2 — TP223 — Data
 Trace 3 — TP219 — Clock

Secure Interface Waveform

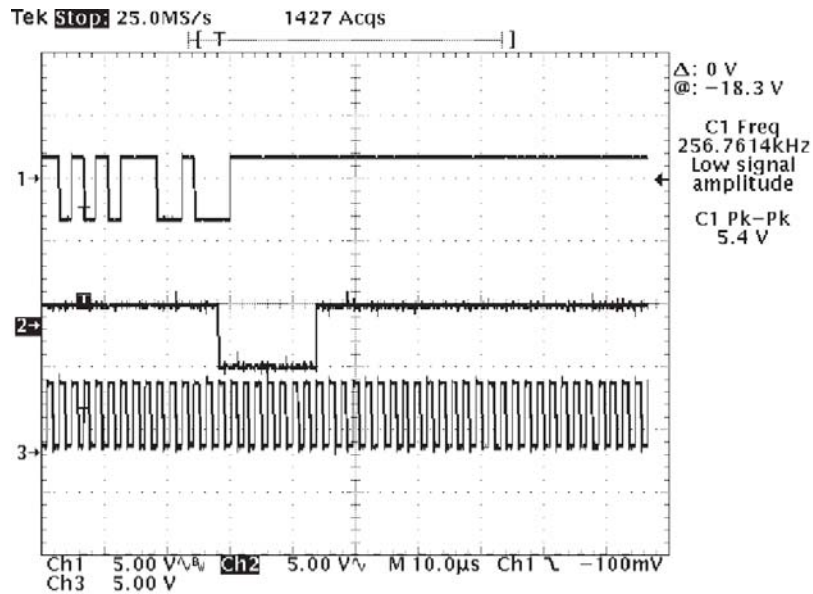

Receiving
 1 kHz tone at 3 kHz Dev, -47dBm Secure Mode
 Trace 1 — P1 — 8 - Data
 Trace 2 — P1 — 10 - SS
 Trace 3 — P1 — 9 - Clock

8 kHz Frame Sync for Security Circuitry Waveform

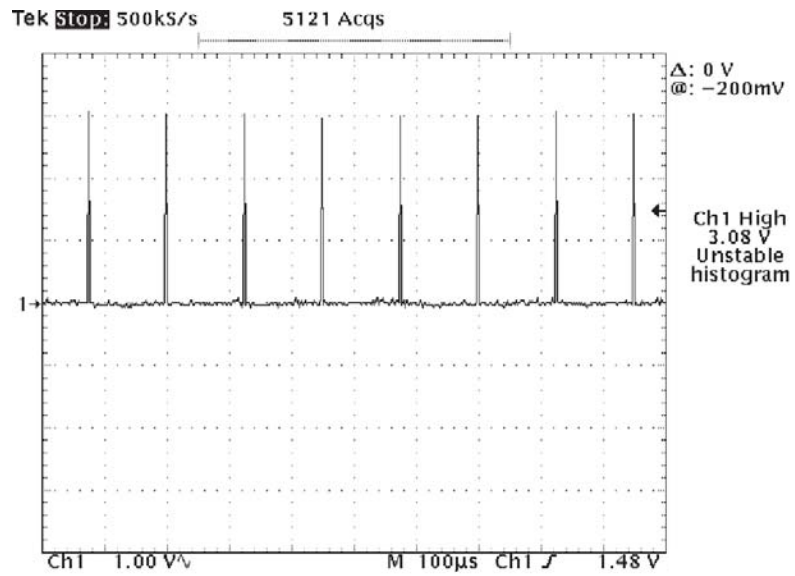

Receiving
1 kHz tone at 3 kHz Dev, -47dBm Secure Mode
Trace 1 — U601 — 5

Notes

Chapter 7 Schematics, Component Location Diagrams and Parts Lists

7.1 List of Schematics and Component Location Diagrams

The following table lists the schematics and component location diagrams contained in this chapter.

Table 7-1. List of Schematics and Component Location Diagrams

Figure Title	Page
ASTRO Spectra Radio Interconnection	7-4
HRN4009B/HRN6014A VHF RF Board, HRN4010B/HRN6020A UHF RF Board, and HRN6019A 800 MHz RF Board Schematic	7-5
HRN4009B/HRN6014A VHF RF Board, HRN4010B/HRN6020A UHF RF Board, and HRN6019A 800 MHz RF Board Component Location Diagrams	7-6
HRN4009C/HRN6014C VHF RF Board Schematic Diagram	7-9
HRN4009C/HRN6014C VHF RF Board Component Location Diagrams	7-10
HRN4009E/HRN6014D VHF RF Board, HRN4010D/HRN6020C UHF RF Board, and HRN6019C 800 MHz RF Board Schematic Diagram (Sheet 1 of 2)	7-12
HRN4009E/HRN6014D VHF RF Board, HRN4010D/HRN6020C UHF RF Board, and HRN6019C 800 MHz RF Board Schematic Diagram (Sheet 2 of 2)	7-13
HRN4009E/HRN6014D VHF RF Board, HRN4010D/HRN6020C UHF RF Board, and HRN6019C 800 MHz RF Component Location Diagram	7-14
HLN5558E/F/G, HLN6529C/D/E/F/G, HLN6560C/D/E/F/G/H, and HLN6562C/D/E/F/G/H Command Board Schematic Diagram	7-17
HLN5558E/F/G, HLN6529C/D/E, HLN6560C/D/E/F/G/H, and HLN6562C/D/E/F/G/H Command Board Component Location Diagrams	7-18
HLN5558H/J, HLN6529H, HLN6560J, and HLN6562J Command Board Schematic Diagram	7-21
HLN5558H/J, HLN6529H, HLN6560J, and HLN6562J Component Location Diagram	7-22
HLN6458D VOCON Board Schematic (Sheet 1 of 2)	7-26
HLN6458D VOCON Board Schematic (Sheet 2 of 2)	7-27
HLN6458D VOCON Board Component Location Diagrams (Sheet 1 of 2)	7-28

Table 7-1. List of Schematics and Component Location Diagrams (Continued)

Figure Title	Page
HLN6458D VOCON Board Component Location Diagrams (Sheet 2 of 2)	7-29
HLN6458E VOCON Board Schematic (Sheet 1 of 2)	7-32
HLN6458E VOCON Board Schematic (Sheet 2 of 2)	7-33
HLN6458E VOCON Board Component Location Diagrams (Sheet 1 of 2)	7-34
HLN6458E VOCON Board Component Location Diagrams (Sheet 2 of 2)	7-35
HLN6458F/G VOCON Board Schematic (Sheet 1 of 2)	7-38
HLN6458F/G VOCON Board Schematic (Sheet 2 of 2)	7-39
HLN6458F/G VOCON Board Component Location Diagrams (Sheet 1 of 2)	7-40
HLN6458F/G VOCON Board Component Location Diagrams (Sheet 2 of 2)	7-41
HLN6458H VOCON Board Schematic (Sheet 1 of 2)	7-44
HLN6458H VOCON Board Schematic (Sheet 2 of 2)	7-45
HLN6458H VOCON Board Component Location Diagrams	7-46
ASTRO Spectra Plus VOCON Top Level Schematic (Sheet 1 of 2)	7-49
ASTRO Spectra Plus VOCON Top Level Schematic (Sheet 2 of 2)	7-50
HLN6837A ASTRO Spectra Plus RF Interface Schematic (Sheet 1 of 2)	7-51
HLN6837A ASTRO Spectra Plus RF Interface Schematic (Sheet 2 of 2)	7-52
HLN6837A ASTRO Spectra Plus Digital/USB Schematic (Sheet 1 of 2)	7-53
HLN6837A ASTRO Spectra Plus Digital/USB Schematic (Sheet 2 of 2)	7-54
HLN6837A ASTRO Spectra Plus Audio/DC Schematic	7-55
HLN6837A ASTRO Spectra Plus Voltage Conversion Schematic	7-56
HLN6837A ASTRO Spectra Plus Secure Interface Schematic	7-57

Table 7-1. List of Schematics and Component Location Diagrams (Continued)

Figure Title	Page
HLN6837A ASTRO Spectra Plus VOCON Component Location Diagram, Top View	7-58
HLN6837A ASTRO Spectra Plus VOCON Component Location Diagram, Bottom View	7-59
HLN6837C ASTRO Spectra Plus VOCON Top Level Schematic (Sheet 1 of 2)	7-62
HLN6837C ASTRO Spectra Plus VOCON Top Level Schematic (Sheet 2 of 2)	7-63
HLN6837C ASTRO Spectra Plus Digital/Memory Schematic (Sheet 1 of 2)	7-64
HLN6837C ASTRO Spectra Plus Digital/Memory Schematic (Sheet 2 of 2)	7-65
HLN6837C ASTRO Spectra Plus Audio/DC Discrete Schematic	7-66
HLN6837C ASTRO Spectra Plus RF Interface Schematic	7-67
HLN6837C ASTRO Spectra Plus Secure Schematic	7-68
HLN6837C ASTRO Spectra Plus VTrans/USB Schematic	7-69
HLN6837C ASTRO Spectra Plus VOCON Component Location Diagram, Top View	7-70
HLN6837C ASTRO Spectra Plus VOCON Component Location Diagram, Bottom View	7-71
HLD6061D and HLD6062D VHF VCO Hybrid Schematic	7-75
HLD6061D and HLD6062D VHF VCO Hybrid Component Location Diagram	7-76
HLD4342B and HLD4343B VHF VCO Carrier Schematic Diagram	7-78
HLD4342D and HLD4343D VHF VCO Carrier Schematic Diagram	7-79
HLD4342B/HLD4343B VHF VCO Carrier Component Location Diagram	7-80
HLD4342D/HLD4343D VHF VCO Carrier Component Location Diagram	7-81
UHF VCO Ranges 1, 2, 3, and 4 Hybrid Schematic	7-84
HLE6101A UHF VCO Range 1 Hybrid and HLE6102A Range 2 Hybrid Component Location Diagram	7-85

Table 7-1. List of Schematics and Component Location Diagrams (Continued)

Figure Title	Page
HLE6103B UHF VCO Range 3 Hybrid and HLE6104B Range 4 Hybrid Component Location Diagram	7-87
UHF VCO Ranges 1, 2, 3, and 4 Schematic Diagram	7-89
HLE6045B Range 1 and HLE6046B Range 2 UHF VCO Component Location Diagram	7-90
HLE6000D Range 3 and HLE6041D Range 4 UHF VCO Component Location Diagrams	7-91
HLF6080B 800 MHz VCO Schematic Diagram	7-93
HLF6080B 800 MHz VCO Component Location Diagram	7-94
HRD6001E/6002E/6011E/6012E VHF Receiver Front-End Schematic	7-96
HRD6001E/6002E/6011E/6012E VHF Component Location Diagram	7-97
HRD6001G/6002G/6011G/6012G VHF Receiver Front-End Schematic	7-101
HRD6001G/6002G/6011G/6012G VHF Receiver Front-End Component Location Diagram	7-102
HRE6001B/6002C/6003B/6004B/6011B/6012B/6014B UHF Receiver Front-End Preamp and Standard Schematics	7-104
HRE6001B/6002C/6003B/6004B/6011B/6012B/6014B UHF Receiver Front-End Hybrid Component Location Diagram	7-105
HRF6004B/C 800 MHz Receiver Front-End Schematic Diagram	7-108
HRF6004B/C 800 MHz Receiver Front-End Component Location Diagram	7-109
HLD6022C VHF 50 Watt PA Schematic	7-111
HLD6022C VHF 50-Watt PA Component Location Diagram, Side 1	7-112
HLD6022C VHF 50-Watt PA Component Location Diagram, Side 2	7-113
HLD6064C VHF Range 1 and HLD6063D Range 2 100-Watt PA Schematic	7-115
HLD6064C VHF Range 1 and HLD6063D Range 2 100-Watt PA Component Location Diagram, Side 1	7-116

Table 7-1. List of Schematics and Component Location Diagrams (Continued)

Figure Title	Page
HLD6064C VHF Range 1 and HLD6063D Range 2 100-Watt PA Component Location Diagram, Side 2	7-117
HLD6032B/HLD6066B VHF 25-Watt PA Schematic	7-119
HLD6032B/HLD6066B VHF 25-Watt PA Component Location Diagram, Side 1	7-120
HLD6032B/HLD6066B VHF 25-Watt PA Component Location Diagram, Side 2	7-121
HLE6062B and HLE6071B UHF 25-Watt PA Schematic	7-124
HLE6062B UHF 25-Watt PA Component Location Diagram, Side 1	7-125
HLE6062B UHF 25-Watt PA Component Location Diagram, Side 2	7-126
HLE6043C, HLE6044C, and HLE6049B UHF 40-Watt PA Schematic	7-128
HLE6043C, HLE6044C, and HLE6049B UHF 40-Watt PA Component Location Diagram, Side 1	7-129
HLE6043C, HLE6044C, and HLE6049B UHF 40-Watt PA Component Location Diagram, Side 2	7-130
HLE6039C, HLE6040C, and HLE6051C UHF 100-Watt PA Schematic	7-134
HLE6039C, HLE6040C, and HLE6051C UHF 100-Watt PA Component Location Diagram, Side 1	7-135
HLE6039C, HLE6040C, and HLE6051C UHF 100-Watt PA Component Location Diagram, Side 2	7-136
HLF6078B 800 MHz 15-Watt PA Schematic	7-141
HLF6078B 800 MHz 15-Watt PA Component Location Diagram, Side 1	7-142
HLF6078B 800 MHz 15-Watt PA Component Location Diagram, Side 2	7-143
HLF6077D 800 MHz 35-Watt PA Schematic	7-145
HLF6077D 800 MHz 35-Watt PA Component Location Diagram, Side 1	7-146
HLF6077D 800 MHz 35-Watt PA Component Location Diagram, Side 2	7-147

7.2 RF Section

Table 7-2. J500 Command Board to RF Board

J500 Pin #	Description	To RF Board
1	SW +5V	J500B-1
2	REF TUNE	J500B-2
3	DOUT*	J500B-3
4	DOUT	J500B-4
5	SBI	J500B-5
6	N/C	J500B-6
7	ODC	J500B-7
8	GND	J500B-8
9	GND	J500B-9
10	SW +9.6V	J500B-10
11	MOD OUT	J500B-11
12	A+	J500B-12
13	GND	J500B-13
14	LOCK DET*	J500B-14
15	KEYED +9.4V	J500B-15
16	ROSC/PSC_CE*	J500B-16
17	REF MOD	J500B-17
18	MOSI	J500B-18
19	SCLK	J500B-19
20	SYN SEL*	J500B-20
21	N/C	J500B-21
22	GND	J500B-22
23	GND	J500B-23
24	GND	J500B-24

Table 7-3. P502 Command Board to Control Head Interconnect Board

P502 Pin #	Description	To Intcon Board
1	SW +9.6V	N/C
2	PTT*/P RESET	N/C
3	EMERGENCY	N/C
4	SPARE 2	N/C
5	DISC AUDIO 2	N/C
6	N/C	J103-27
7	GND	J103-3
8	VRS RX AUDIO	N/C
9	BUSY	J103-25
10	GND	N/C
11	LH RESET	J103-23
12	VRS TX AUDIO	N/C
13	DISC AUDIO	N/C
14	VIP OUT 1	J103-8
15	P RS DATA	J103-21
16	BOOT/VPP	J103-20
17	VO 2	J103-19
18	VO 1	J103-18
19	RX/RS232	N/C
20	TX/RS232	N/C
21	IGN SW B+	J103-11
22	BUS-	J103-10
23	KEYFAIL*/TX	J103-9
24	PTTB/VIP IN 1	N/C
25	BUS+	J103-22
26	CTS/RS232	N/C
27	VIP OUT 2	J103-7
28	GND	J103-6
29	HUB/BUSY	N/C
30	A+	J103-5
31	SW B+	J103-4
32	KEYED SLOT	—
33	RTS/RS232	N/C
34	SPEAKER LOW	N/C
35	SPEAKER HIGH	N/C
36	UNSW +5V	N/C

Table 7-3. P502 Command Board to Control Head Interconnect Board (Continued)

P502 Pin #	Description	To Intcon Board
37	SW +5V	N/C
38	VIP IN 2	N/C

Table 7-4. P503 Command Board to RF Power Amplifier Board

P503 Pin #	Description	To RF PA Board
1	CONT VOLT LIMIT	P853-2
2	CONT VOLT DRIVE	P853-3
3	CURRENT SENSE +	P853-4
4	KEYED +9.4V	P853-5
5	A+	P853-6
6	TEMP SENSE	P853-7
7	KEYED SLOT	P853-8
8	FWD DET VOLT	P853-9
9	A+	P853-10
10	SW +9.6V	P853-11
11	CURRENT SENSE-	P853-12
12	GND	J2-8
13	MIC HI/RESET/RTS RS232	J2-15
14	SPEAKER LOW	J2-7
15	BUS+	J2-14
16	SPEAKER HIGH	J2-6
17	PTT*/TX RS232	J2-13
18	IGN/SW B+	J2-5
19	V_OUT 1	J2-12
20	SW B+	J2-4
21	DISC AUD/RX RS232	J2-11
22	V_OUT 2	J2-3
23	BUS-	J2-10
24	EMERGENCY	J2-2
25	BUSY	J2-9

Table 7-5. Configuring Command Board Jumpers for Non-RS232 Operation

Jumper	Function			
	MIC HI	PTT	DISC AUD	VRS TX
JU518		OUT		
JU519			OUT	
JU520				OUT
JU521	OUT			
JU513	IN			
JU500		IN		
JU528			IN	
JU515				IN

Table 7-6. J501 Command Board to VOCON Board

J501 Pin #	Description	Command Board	VOCON Board
1	DOUT*	J500-3	U406-H3
2	DOUT	J500-4	U406-K3
3	GROUND	P503-12	GROUND
4	GROUND	P503-12	GROUND
5	CTSOUT*	U526-13	CTSOUT*
6	SBI	J500-5	U406-J3
7	DOC	J500-7	U406-F3
8	SPI SCK	J500-19	U204-G5
9	MOSI	J500-18	U204-J6
10	LOCK DET*	J500-14	U206-K2
11	SYN SEL*	J500-20	U204-H7
12	ROSC/PSC CE*	J500-16	U204-F6
13	DA SEL*	U502-25	U204-H5
14	TXPA EN*	U500-33	U206-G9
15	5V EN*	CR401	U206-F8
16	EMERG	Q507	U204-A3
17	BOOT DATA IN	U525-14	U206-J2/ U204-J7
18	BOOT DATA OUT	U522-19	U204-G6
19	BUSY OUT	U522-13	U206-K8
20	SB9600 BUSY	U522-11	U204-J3
21	KEYFAIL*	U525-1	U206-J8/J801-15

Table 7-6. J501 Command Board to VOCON Board

J501 Pin #	Description	Command Board	VOCON Board
22	VIP OUT1	P502-14	U206-E7
23	VIP OUT2	P502-27	U206-J3
24	VIP IN1	Q512	U206-A7
25	VIP IN2	A513	U206-D5
26	MOB IRQ*	U522-24	U206-B4
27	LHRST0*	U522-8	U206-B7
28	LHRST1	Q511	U206-A8
29	POR*	U522-40	U206-C9/ U409-2
30	INT PTT*	U522-38	U206-H2
31	OPTB+/BOOT SEL/ VPP	P502-16	CR201
32	TAMPER	GND	J801-6
33	+5V	Q502	+5V
34	+5V	Q502	+5V
35	B+ SENSE	P502-31	B+ SENSE
36	KG BACKUP	JU527	J801-23
37	+5VA	U500-14	+5VA
38	UNSW B+	Q508	UNSW B+
39	MAI	U524	U406-C1
40	SDO	U524-1	U406-B5
41	LATCH SEL*	U530-12	U206-G8
42	RTSIN*	U526-14	U206-J8
43	RS232 DATA OUT	U526-15	U206-A5
44	SPKREN	Q401	U206-G4
45	MICEN	Q404	U206-G7
46	GROUND	P503-12	GROUND
47	GROUND DIGITAL	P503-12	GRD DIGITAL
48	REFMOD	U401-5	U406-B1
49	MODIN	U401-3/ JU530	U406-B2
50	RS232 DATA IN	U526-16	U206-B2

Table 7-7. J801 VOCON Board to Encryption Board

J801 Pin #	Description	To Encryption Board
1	SW B+	J401-17
2	SW B+	J401-17
3	EMC RXO	U405-B7
4	EMC TXO	U405-A7
5	N/C	
6	GROUND	
7	MISO	U204-H6
8	MOSI	U204-J6 J601-1
9	SPI SCK	U204-G5 J601-2
10	EMC EN*	U206-D6
11	EMC REQ*	U206-H3
12	EMC MAKEUP*	U206-K7
13	N/C	
14	N/C	
15	KEYFAIL*/RTSIN*	U206-J8
16	N/C	
17	N/C	
18	N/C	
19	N/C	
20	UNSW B+	J401-19
21	GROUND	
22	GROUND	
23	N/C	
24	N/C	
25	N/C	

Table 7-8. J601 RF Board to VCO Board

J601 Pin #	Description	To VCO Board
1	SYNTH-FDBK	P601-1
2	+9.6V	P601-2
3	POS-S.L.	P601-3
4	NEG-S.L.	P601-4
5	KEYED-9.4V	P601-5
6	DATA	P601-6
7	CLOCK	P601-7
8	SEL	P601-8
9	AUX-2	P601-9
10	VCO-MOD	P601-10
11	AUX-1	P601-11
12	S.F.8.6V	P601-12

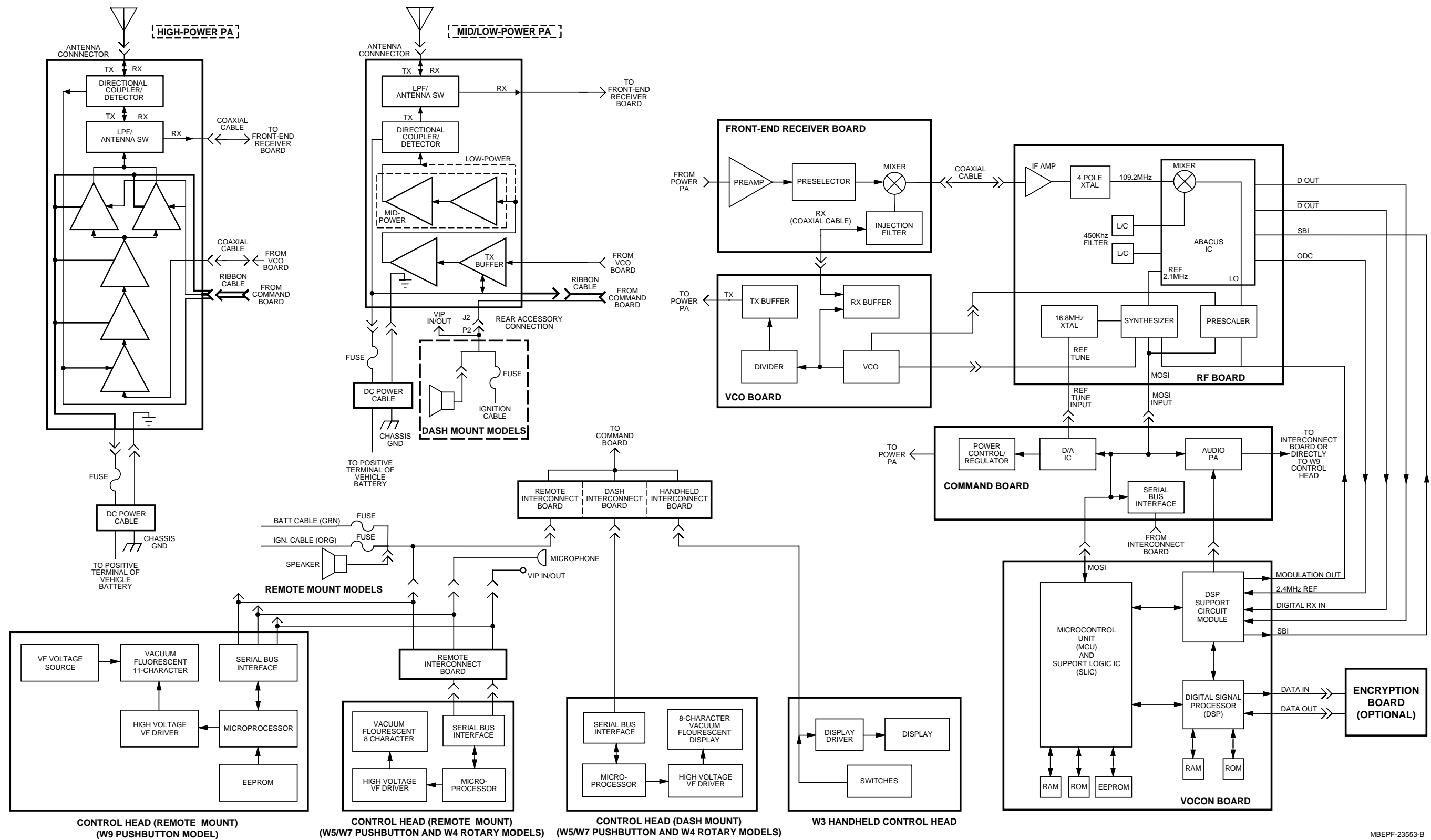

MBEPF-23553-B

ASTRO Spectra Radio Interconnection

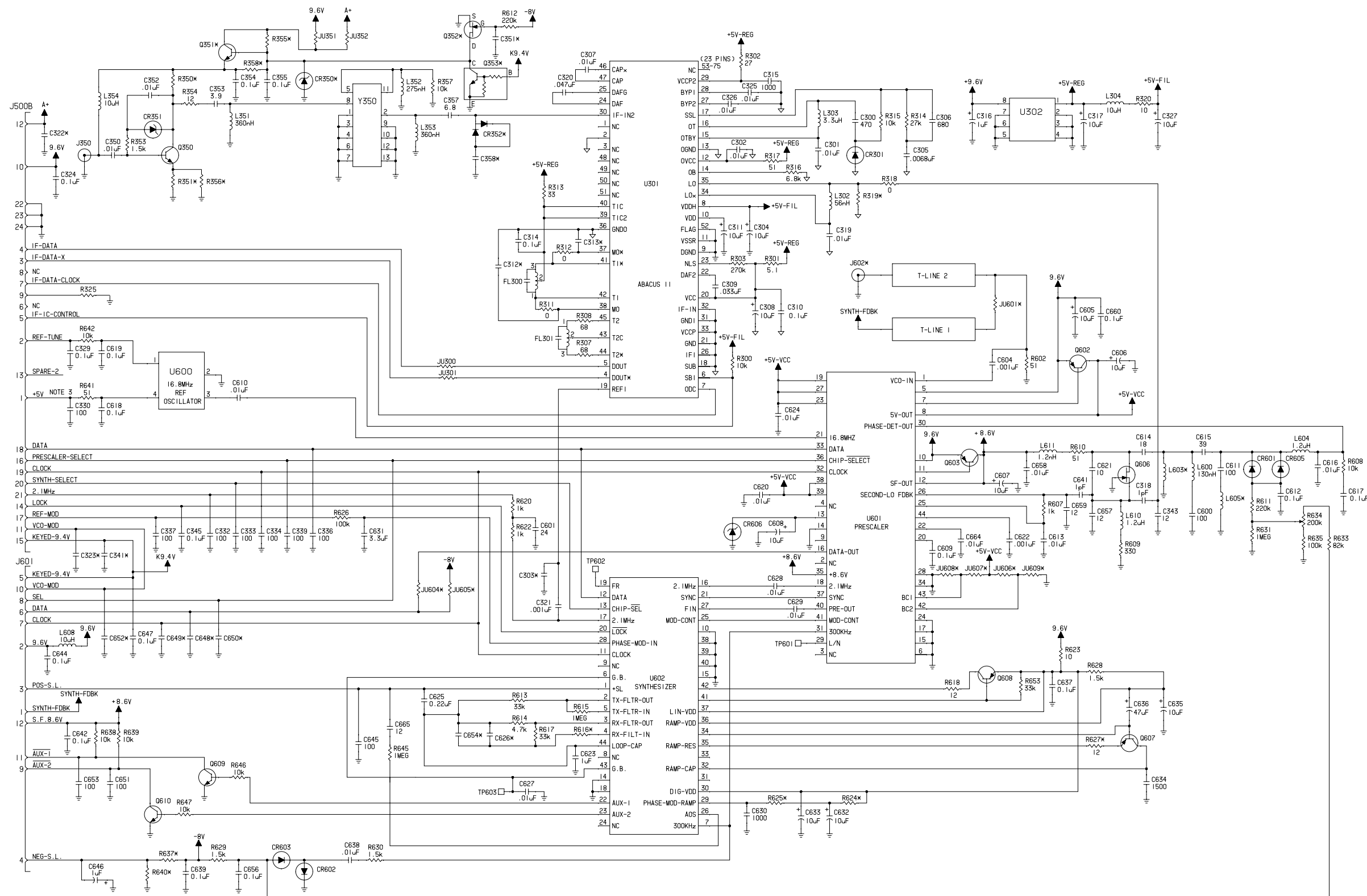

- NOTES:
- 1) ALL RESISTANCE IN OHMS, ALL CAPACITANCE IN PICOFARADS UNLESS NOTED OTHERWISE.
 - 2) * DENOTES BAND DEPENDENT PART.
 - 3) THIS 5V SOURCE ORIGINATES ON THE COMMAND BOARD. IT IS NOT COMMON TO ANY OTHER 5V SOURCE ON THIS BOARD.
 - 4) A NUMBER OF PARTS ON THIS BOARD WERE DESIGNED IN AS CONTINGENCIES FOR ENHANCEMENT. IF A PART IS MARKED WITH AN ASTERISK, BUT DOES NOT HAVE AN ENTRY IN THE TABLE OR IN THE KIT PARTS LIST, IT IS ONE OF THESE CONTINGENCY PARTS.

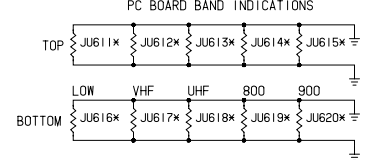

COMPONENT VALUE TABLE FOR BAND DEPENDENT PARTS

PART DESC.	VHF VALUE	UHF VALUE	800 VALUE
J605	OUT	IN (O)	IN (O)
J606	OUT	IN (O)	OUT
J607	IN (O)	OUT	IN (O)
J608	OUT	IN (O)	OUT
J609	IN (O)	OUT	IN (O)
R624	10k	4.7k	4.7k
R625	22k	6.8k	1.5k
R627	4.7k	2.2k	1.8k
R616	22k	12k	10k
C654	1500	UNUSED	1500
C626	1500	1500	1500
J351	IN	OUT	IN
J352	OUT	IN	OUT
R350	120	220	120
R351	18	27	18
R355	0	10k	0
R356	2.2	120	2.2
R359	2.2	15V	2.2
C351	0.1	0.1	0.1
C355	0.1	2.2	0.1
R612	220k	220k	1M
R640	220k	220k	1M
J601	IN	IN	IN
C341	100	100	100

MAEPF-27086-0

HRN4009B/HRN6014A VHF RF Board, HRN4010B/HRN6020A UHF RF Board, and HRN6019A 800 MHz RF Board Schematic

HRN4009B, HRN6014A VHF RF Board
 HRN4010B, HRN6020A UHF RF Board
 HRN6019A 800 MHz RF Board
 Electrical Parts List

ITEM	MOTOROLA PART NUMBER	DESCRIPTION
		CAPACITOR, Fixed: unless otherwise stated
C300	2113740B65	470pF
C301, 302	2113741N45	.01μF
C303	-----	Not Placed
C304	2311049J26	10pF
C305	2113741B41	6800pF
C306	2113740B69	680pF
C307	2113741N45	.01μF
C308	2311049J26	10pF
C309	2113741N57	.033μF
C310	2113741N69	0.1μF
C311	2311049J26	10pF
C312, 313	-----	Not Placed
C314	2113741N69	0.1μF
C315	2113740B73	1000pF
C316	2113743G21	1.0μF (VHF Bd)
	or 2311049A37	1.0μF (UHF and 800MHz Bds)
C317	2311049J26	10pF
C318	2113740B31	18pF
C319	2113741N45	.01μF
C320	2113741N61	.047μF
C321	2113741N21	1000pF
C322	2113741N69	0.1μF (Placed on UHF Bd Only)
C323	-----	Not Placed
C324	2113741N69	0.1μF
C325, 326	2113741N45	.01μF
C327	2311049J26	10pF
C328	-----	Not Placed
C329	2113741N69	0.1μF
C330	2113740B49	100pF
C332 thru 334	2113740B49	100pF
C336, 337	2113740B49	100pF
C339	2113740B49	100pF
C341	2113740B49	100pF (Placed on VHF Bd Only)
C343	2113740B27	12pF
C345	2113741N69	0.1μF
C350	2113741N45	.01μF
C351	2113741N69	0.1μF (Placed on UHF Bd Only)
C352	2113741N45	.01μF
C353	2113740B15	3.9pF (VHF Bd)
	or 2113740B13	3.3pF (UHF Bd)
	or 2113740B19	5.6pF (800MHz Bd)
C354	2113741N69	0.1μF
C355	2113741N69	0.1μF (VHF and 800MHz Bds)
	or 2311049J04	2.2μF (UHF Bd)
C357	2113740B17	4.7pF (VHF Bd))

ITEM	MOTOROLA PART NUMBER	DESCRIPTION
	or 2113740B13	3.3pF (UHF and 800 MHz Bds)
C358	2113741N69	0.1μF (Placed on VHF Bd Only)
C600	2113740B49	100pF
C601	2113740B34	24pF
C604	2113741N21	1000pF
C605	2380090M06	10pF
C606, 607	2311049J26	10pF
C608	2380090M06	10pF
C609	2113741N69	0.1μF
C610	2113741N45	.01μF
C611	-----	Not Placed
C612	2113741N69	0.1μF
C613	2113741N45	.01μF
C614	2113740B31	18pF
C615	2113740B39	39pF
C616	2113741N45	.01μF
C617 thru 619	2113741N69	0.1μF
C620	2113741N45	.01μF
C621	2113740B25	10pF
C622	2113741N21	1000pF
C623	0880027B09	100pF
C624	2113741N45	.01μF
C625	2113741D28	0.22μF
C626	2113740B76	1500pF (VHF and UHF Bds)
	or 2113741N45	.01μF (800MHz Bd)
C627 thru 629	2113741N45	.01μF
C630	2113740B73	1000pF (VHF Bd)
	or -----	Not Placed (UHF Bd)
	or 2113740B76	1500pF (800MHz Bd)
C631	2311049J07	3.3pF
C632	2380090M06	10pF
C633	2311049J26	10pF
C634	2113740B76	1500pF
C635	2380090M06	10pF
C636	2380090M07	47pF
C637	2113741N69	0.1μF
C638	2113741N45	.01μF
C639	2113741N69	0.1μF
C641	2113740B01	1.0pF
C642	2113741N69	0.1μF
C644	2113741N69	0.1μF
C645	2113740B49	100pF (VHF and UHF Bds)
	or 2113741N45	.01μF (800MHz Bd)
C646	2113743G21	1.0μF (VHF Bd)
	or 2311049A37	1.0μF (UHF and 800MHz Bds)
C647	2113741N69	0.1μF
C648 thru 650	-----	Not Placed
C651	2113740B49	100pF
C652	2113740B49	100pF (Placed on UHF Bd Only)
C653	2113740B49	100pF
C654	2113740B76	1500pF (VHF Bd)

ITEM	MOTOROLA PART NUMBER	DESCRIPTION
	or -----	Not Placed (UHF Bd)
	or 2113741N45	.01μF (800MHz Bd)
C656	2113741N69	0.1μF
C657	2113740B27	12pF
C658	2113741N45	.01μF
C659	2113740B27	12pF
C660	2113741N69	0.1μF
C664	2113741N45	.01μF
C665	2113740B27	12pF
CR301	4880006E09	Varactor
CR350	-----	Not Placed (VHF and 800MHz Bds)
	or 4813830A28	(UHF Bd)
CR351	4882958R39	(VHF and 800MHz Bds)
	or 4882958R78	(UHF Bd)
CR352	4880154K03	Dual; Schottky (VHF Bd)
	or -----	Not Placed (UHF and 800MHz Bds)
CR601	4880006E09	Varactor
CR602, 603	4811058B11	
CR605	-----	Not Placed
CR606	4813830A28	
E301	2680003M03	Ferrite Bead
E302	2680004M03	Ferrite Bead
E602	2680006M02	Ferrite Bead
FL300, 301	9185128U02	FILTER: See Note 2. LC; 450kHz
J350	0980110M01	Receptacle, Coaxial
J500	0980104M02	Receptacle, Bottom-Entry
J601	0980103N02	Sockets, 12-Position
J602	-----	Not Placed
JU300, 301	0611077A01	0W
JU351	0611077A01	0W (Placed on UHF and 800MHz Bds Only)
JU352	0611077A01	0W (Placed on UHF Bd Only)
JU601	0611077A01	0W
JU604	-----	Not Placed
JU605	0611077A01	0W (Placed on VHF and 800MHz Bds Only)
JU606	0611077A01	0W (Placed on UHF Bd Only)
JU607	0611077A01	0W (Placed on VHF and 800MHz Bds Only)
JU608	0611077A01	0W (Placed on UHF Bd Only)
JU609	0611077A01	0W (Placed on VHF and 800MHz Bds Only)

ITEM	MOTOROLA PART NUMBER	DESCRIPTION
JU611	-----	Not Placed
JU612	0611077A01	0W (Placed on VHF Bd Only)
JU613	0611077A01	0W (Placed on UHF Bd Only)
JU614	0611077A01	0W (Placed on 800MHz Bd Only)
JU615, 616	-----	Not Placed
JU617	0611077A01	0W (Placed on VHF Bd Only)
JU618	0611077A01	0W (Placed on UHF Bd Only)
JU619	0611077A01	0W (Placed on 800MHz Bd Only)
JU620	-----	Not Placed
L302	2411087A11	COIL, RF: unless otherwise stated .056μH (Placed on UHF Bd Only)
L303	2411087A32	3.3μH
L304	2480140E16	10μH
L351	2480140E11	360nH (VHF and UHF Bds)
	or 2405452C78	295nH (800MHz Bd)
L352	2405452C78	295nH (VHF Bd)
	or 2480140E15	275nH (UHF and 800MHz Bds)
L353	2405452C78	295nH (VHF Bd)
	or 2405452C90	400nH (UHF and 800MHz Bds)
L354	2480140E16	10μH
L600	2480140E06	130nH
L603	-----	Not Placed
L604	2480140E01	1.2μH
L605	-----	Not Placed
L608	2480140E16	10μH
L610, 611	2480140E01	1.2μH
Q350	4802000P02	TRANSISTOR: See Note 1. NPN
Q351	4880052M01	NPN; Darlington (Placed on UHF Bd Only)
Q352	4884235R02	SOT (Placed on UHF Bd Only)
Q353	4880048M01	NPN (Placed on UHF Bd Only)
Q602, 603	4805128M27	SOT89
Q606	4884235R02	SOT
Q607	4880182D48	PNP
Q608	4880141L01	PNP; SOT23
Q609, 610	4880141L02	NPN; SOT23
R300	0611077A98	RESISTOR: Ohms ±5%; 1/8W unless otherwise stated 10k
R301	0611077A19	5.1
R302	0611077A36	27
R303	0611077B33	270k
R307, 308	0611077A46	68
R311, R312	0611077A01	0
R313	0611077A38	33
R314	0611077B09	27k
R315	0611077A98	10k

ITEM	MOTOROLA PART NUMBER	DESCRIPTION
R316	0611077A94	6.8k
R317	0611077A43	51
R318	0611077A01	0
R319	-----	Not Placed
R320	0611077A26	10
R325	-----	Not Placed
R350	0611077A58 or 0611077A58	220 (VHF and 800MHz Bds) 120 (UHF Bd)
R351	0611077A26 or 0611077A36	10 (VHF and 800MHz Bds) 27 (UHF Bd)
R353	0611077A78	1.5k
R354	0611077A28	12
R355	0611077A01 or 0611077A98	0 (VHF and 800MHz Bds) 10k (UHF Bd)
R356	0611077A38 or 0611077A52	33 (VHF and 800MHz Bds) 120 (UHF Bd)
R357	0611077A98	10k
R358	0611077A10	2.2 (Placed on VHF and 800MHz Bds Only)
R602	0611077A43	51
R607	0611077A74	1k
R608	0611077A98	10k
R609	0611077A62	330
R610	0611077A43	51
R611	0611077B31	220k
R612	0611077B31	220k (Placed on UHF Bd only)
R613	0611077B11	33k
R614	0611077A90	4.7k
R615	0611077B47	1M
R616	0611077B07 or 0611077B01 or 0611077A98	22k (VHF Bd) 12k (UHF Bd) 10k (800MHz Bd)
R617	0611077B11	33k
R618	0611077A28	12
R620	0611077A74	1k
R622	0611077A74	1k
R623	0611077A26	10
R624	0611077A98 or 0611077A90	10k (VHF Bd) 4.7k (UHF and 800MHz Bds)
R625	0611077B07 or 0611077A96 or 0611077A78	22k (VHF Bd) 8.2k (UHF Bd) 1.5k (800MHz Bd)
R626	0611077B23	100k
R627	0611077A90 or 0611077A82 or 0611077A80	4.7k (VHF Bd) 2.2k (UHF Bd) 1.8k (800MHz Bd)
R628 thru 630	0611077A78	1.5k
R631	0611077B47	1M
R633	0611077B21	82k
R634	1880273N01	Potentiometer
R635	0611077B23	100k

ITEM	MOTOROLA PART NUMBER	DESCRIPTION
R637	0611077B31 or 0611077B47	220k (VHF and UHF Bds) 1M (800MHz Bd)
R638, 639	0611077A98	10k
R640	0611077B31 or 0611077B47	220k (VHF and UHF Bds) 1M (800MHz Bd)
R641	0611077A43	51
R642	0611077A98	10k
R645	0611077B47	1M
R646, 647	0611077A98	10k
R648	-----	Not Placed
R653	0611077B11	33k
INTEGRATED CIRCUIT MODULE: See Note 1.		
U301	5105835U90	Hybrid, ABACUS (800MHz Bd)
U302	5105469E90	5V Regulator
U600	5180291B09 or 5180291B11	Reference Oscillator; 16.8MHz (VHF and UHF Bds) Reference Oscillator; 16.8MHz (800MHz Bd)
U601	5180057S09	Prescaler
U602	5180057S10	Synthesizer
CRYSTAL: See Note 1.		
Y350	9180084M01	109.65MHz
MISCELLANEOUS:		
	2605256X01	Shield, Filter
	7580094M06	Pad, VF Shock
	8405884V02	Circuit Board

Notes:

- For optimum performance, order replacement diodes, transistors, and circuit modules by Motorola part number only.
- When ordering crystals, specify carrier frequency, crystal type number, and Motorola part number.
- Part value notations:
 $p=10^{-12}$
 $n=10^{-9}$
 $\mu=10^{-6}$
 $m=10^{-3}$
 $k=10^3$
 $M=10^6$
- ITEM refers to the component reference designator.
- The RF Board Kits use a 6-layer printed circuit board.

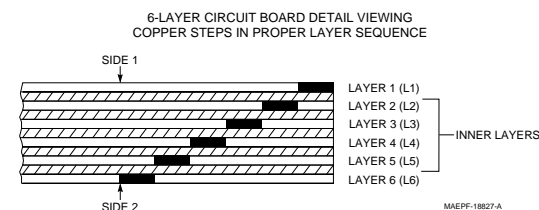

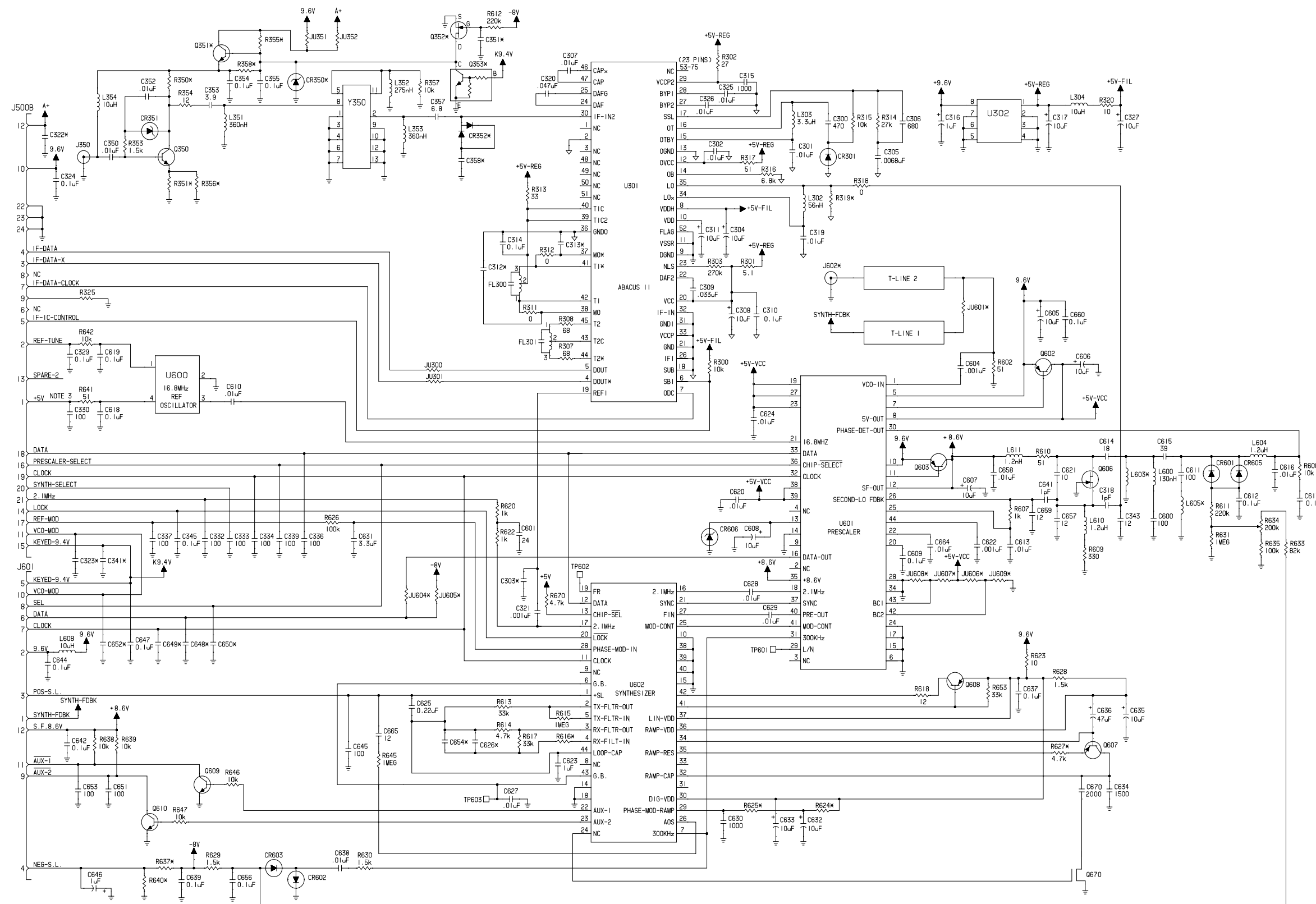

- NOTES:
- 1) ALL RESISTANCE IN OHMS, ALL CAPACITANCE IN PICOFARADS UNLESS NOTED OTHERWISE.
 - 2) * DENOTES BAND DEPENDENT PART. (SEE TABLE AND PARTS LIST.)
 - 3) THIS 5V SOURCE ORIGINATES ON THE COMMAND BOARD. IT IS NOT COMMON TO ANY OTHER 5V SOURCE ON THIS BOARD.
 - 4) A NUMBER OF PARTS ON THIS BOARD WERE DESIGNED IN AS CONTINGENCIES FOR ENHANCEMENT. IF A PART IS MARKED WITH AN ASTERISK, BUT DOES NOT HAVE AN ENTRY IN THE TABLE OR IN THE KIT PARTS LIST, IT IS ONE OF THESE CONTINGENCY PARTS.

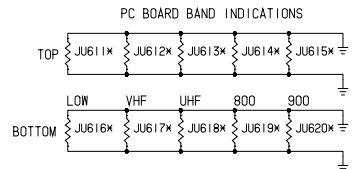

COMPONENT VALUE TABLE FOR BAND DEPENDENT PARTS

PART DESC.	VHF VALUE	UHF VALUE	800 VALUE
JU605	OUT	IN (O)	IN (O)
JU606	OUT	IN (O)	OUT
JU607	IN (O)	OUT	IN (O)
JU608	OUT	IN (O)	OUT
JU609	IN (O)	OUT	IN (O)
R624	10k	4.7k	4.7k
R625	22k	6.8k	1.5k
R627	4.7k	2.2k	1.8k
R616	22k	12k	10k
R654	1500	UNUSED	1500
R626	1500	1500	1500
JU351	IN	OUT	IN
JU352	OUT	IN	OUT
R350	120	220	120
R351	18	27	18
R355	0	10k	0
R356	2.2	120	2.2
R358	0.1	15V	0.1
C351	0.1	0.1	0.1
C355	0.1	2.2	0.1
R612	220k	220k	220k
Q351	NPN		
Q352	J310		
Q353	NPN		
R637	220k	220k	1M
R640	220k	220k	1M
JU601	IN	IN	IN
C341	100		

MAEPF-27089-O

HRN4009C/HRN6014C VHF RF Board Schematic Diagram

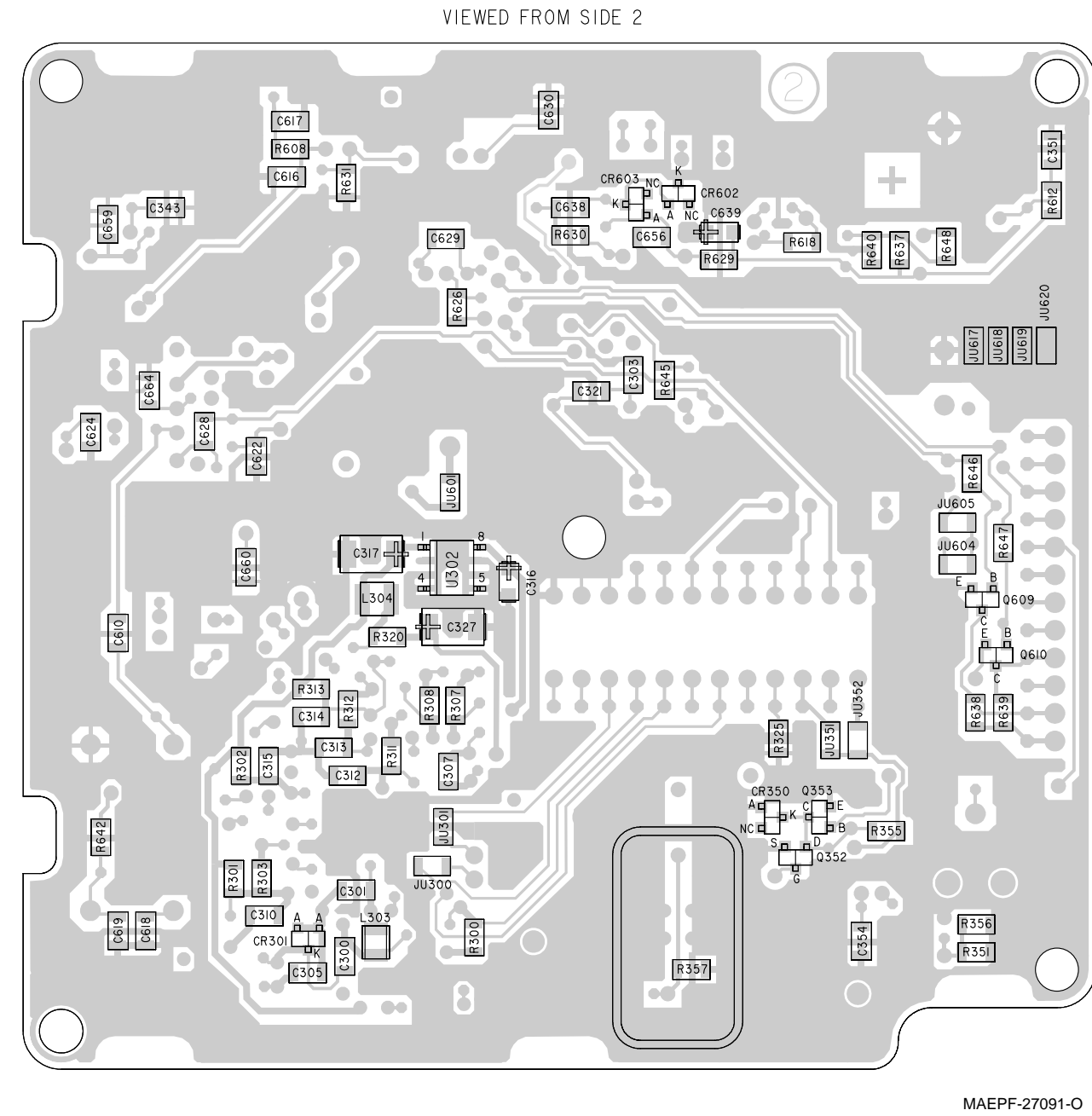
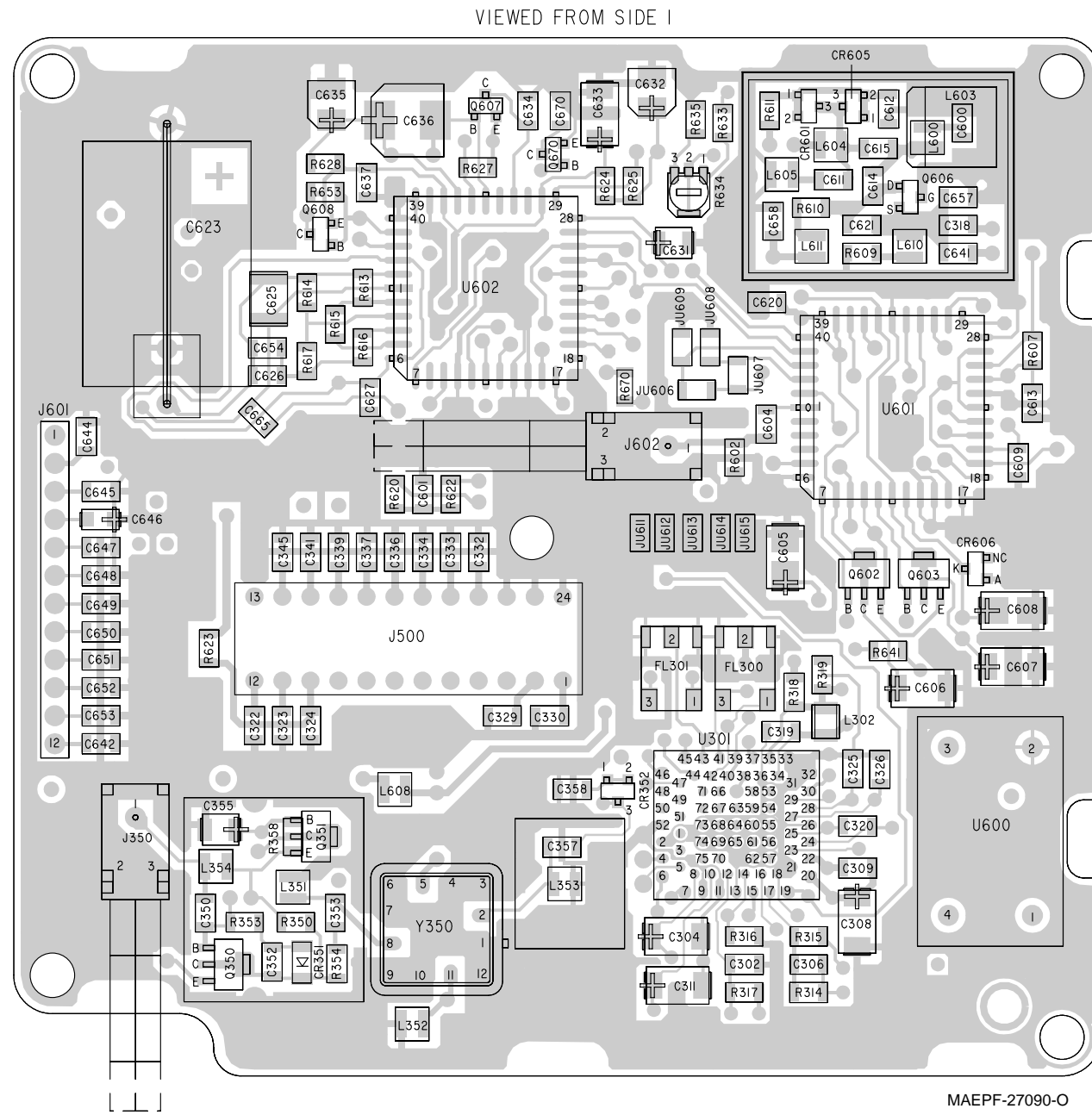

HRN4009C/HRN6014C VHF RF Board Component Location Diagrams

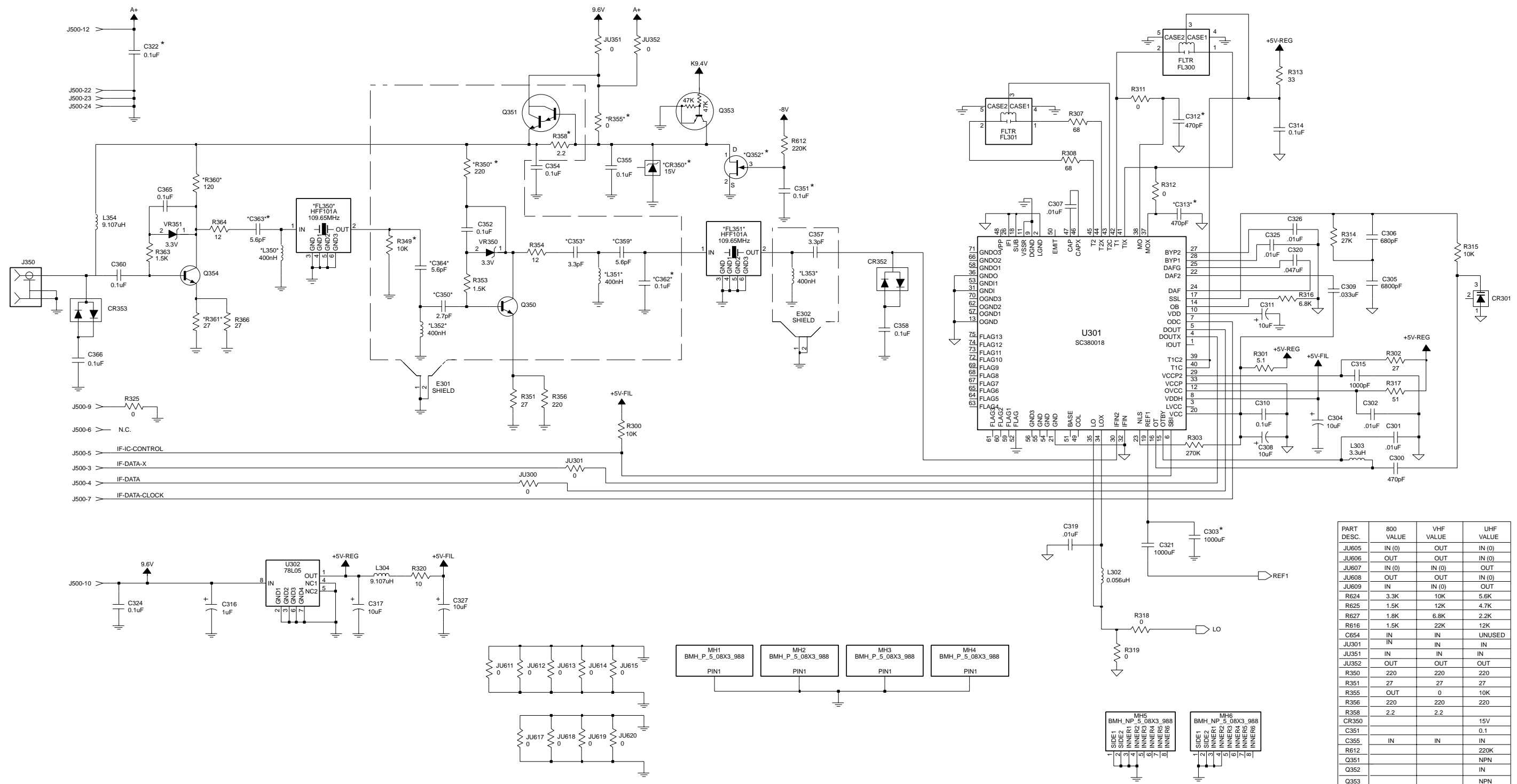

HRN4009E/HRN6014D VHF RF Board, HRN4010D/HRN6020C UHF RF Board, and HRN6019C 800 MHz RF Board Schematic Diagram (Sheet 1 of 2)

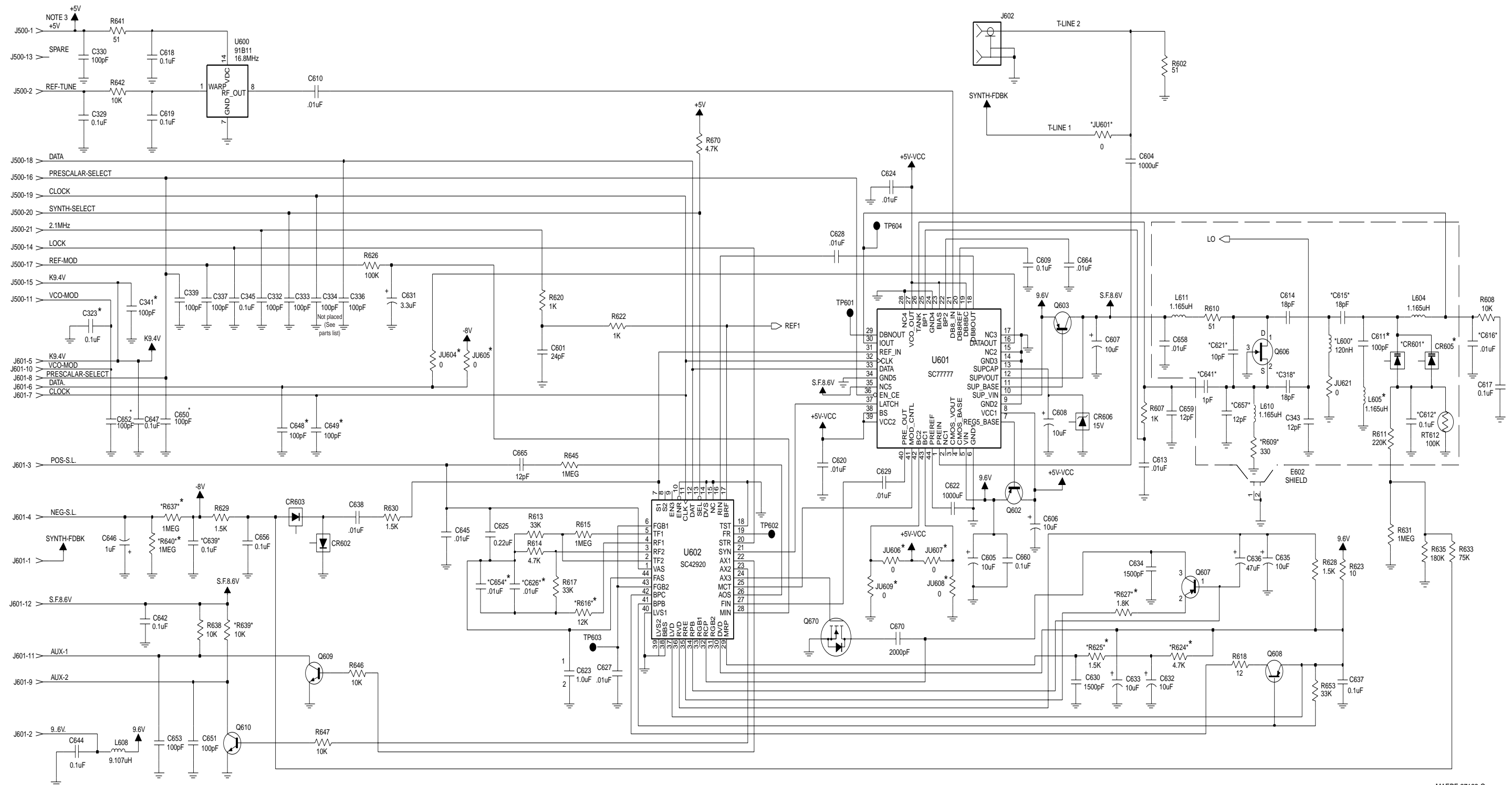

MAEPF-27122-0
SHEET 2

HRN4009E/HRN6014D VHF RF Board, HRN4010D/HRN6020C UHF RF Board, and HRN6019C 800 MHz RF Board Schematic Diagram (Sheet 2 of 2)

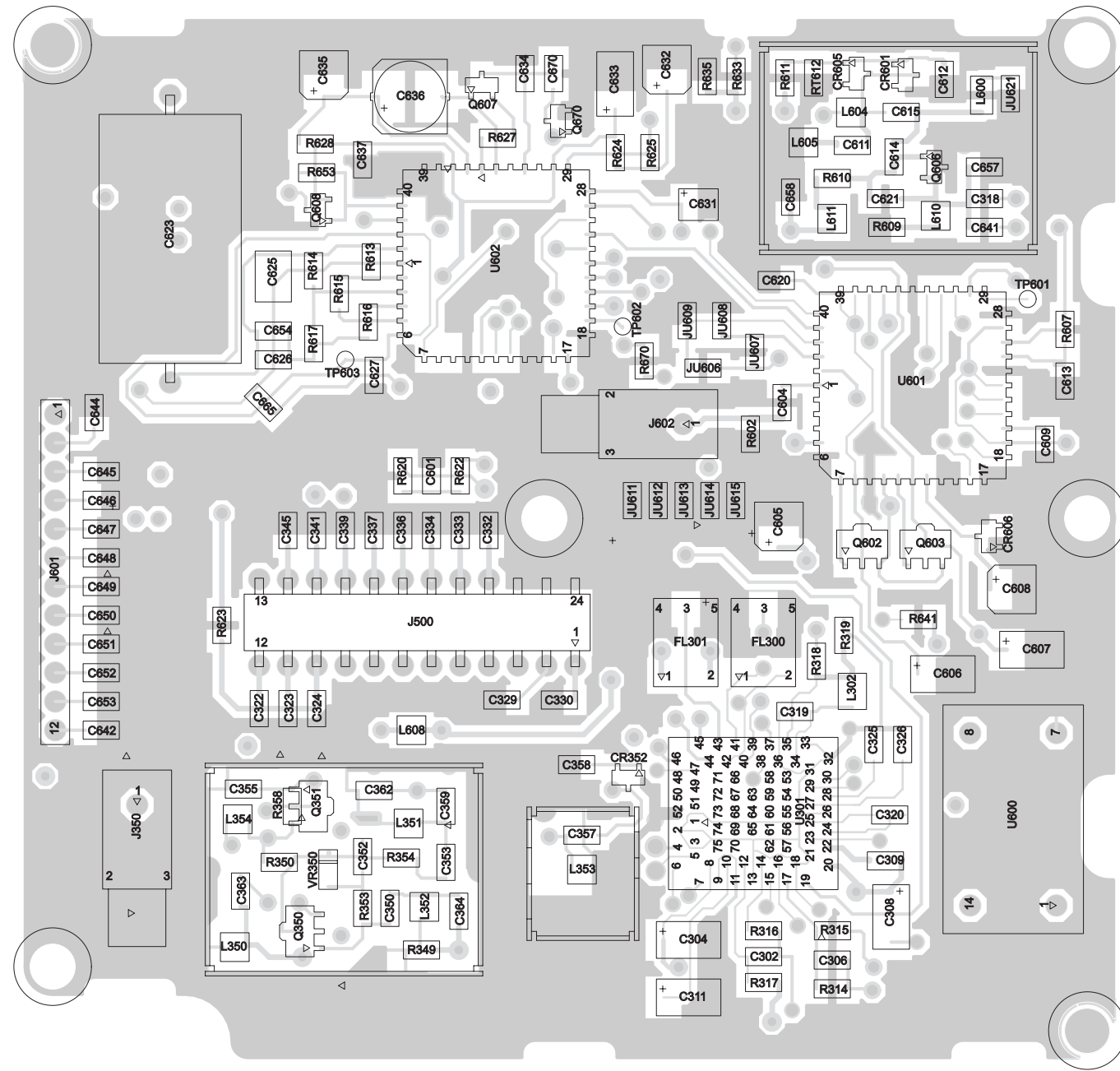

Side 1

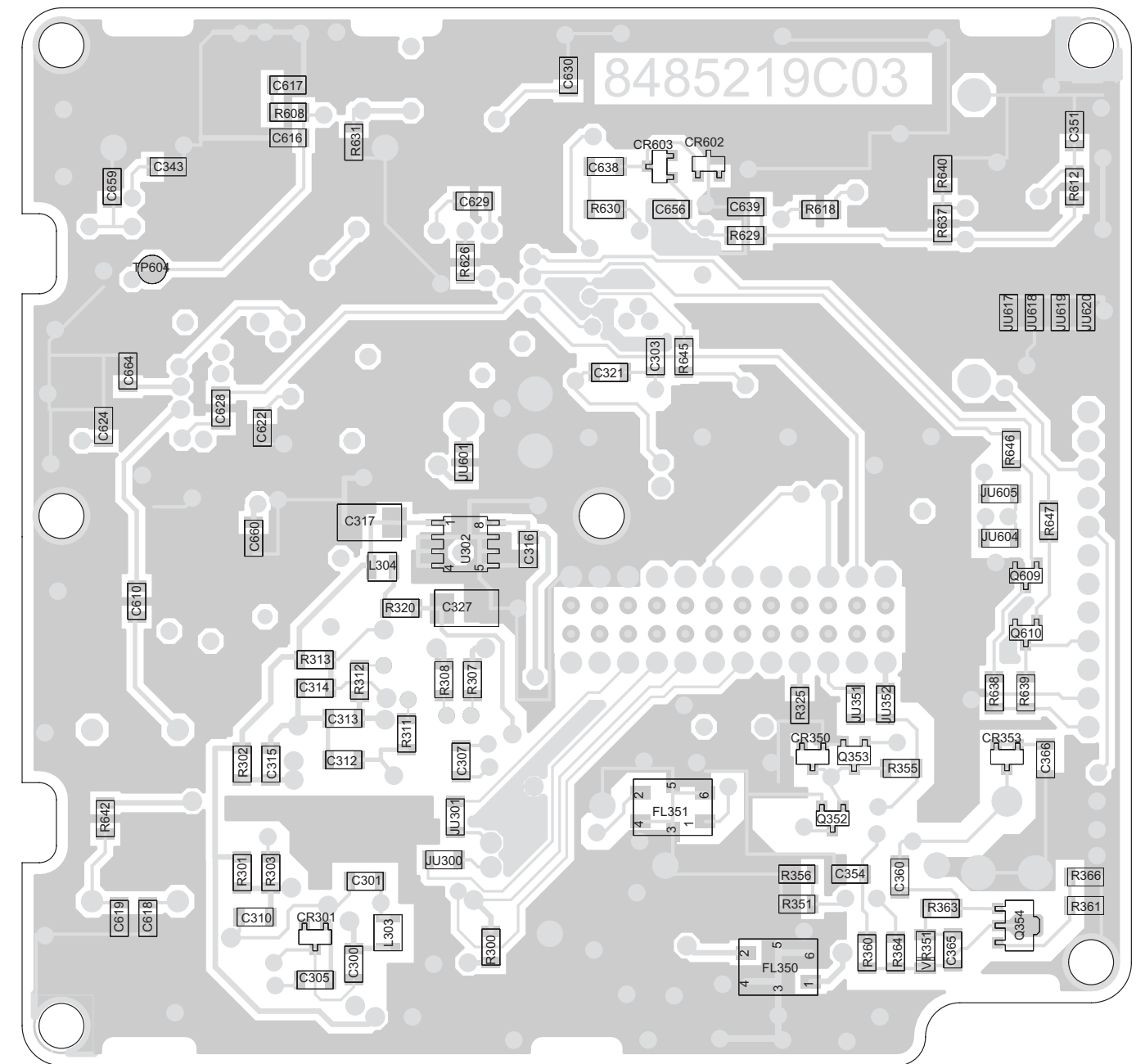

Side 2

HRN4009E/HRN6014D VHF RF Board, HRN4010D/HRN6020C UHF RF Board, and HRN6019C 800 MHz RF Component Location Diagram

**HRN4009E and HRN6014D VHF RF Board, HRN6010D
and HRN6020C UHF RF Board, and HRN6019C 800
MHz RF Board Parts Lists**

ITEM	MOTOROLA PART NUMBER	DESCRIPTION
		CAPACITOR, Fixed: unless otherwise stated
C300	2113740B65	470pF
C301, 302	2113741N45	.01µF
C303	-----	Not Placed
C304	2311049J26	10pF
C305	2113741B41	6800pF
C306	2113740B69	680pF
C307	2113741N45	.01µF
C308	2311049J26	10pF
C309	2113741N57	.033µF
C310	2113741N69	0.1µF
C311	2311049J26	10pF
C312, 313	-----	Not Placed
C314	2113741N69	0.1µF
C315	2113740B73	1000pF
C316	2311049A37	1.0µF
C317	2311049J26	10pF
C318	2113740B31	18pF
C319	2113741N45	.01µF
C320	2113741N61	.047µF
C321	2113741N21	1000pF
C322, 323	2113741N69	0.1µF (Placed on UHF Bd Only)
C324	2113741N69	0.1µF
C325, 326	2113741N45	.01µF
C327	2311049J26	10pF
C329	2113741N69	0.1µF
C330	2113740B49	100pF
C332, 333	2113740B49	100pF
C334	2113740B49	100pF/Not Placed (see Note 6)
C336, 337	2113740B49	100pF
C339	2113740B49	100pF
C341	2113740B49	100pF (Placed on VHF Bd Only)
C343	2113740B27	12pF
C345	2113741N69	0.1µF
C350	2113740B09	2.2pF
C351	2113741N69	0.1µF (Placed on UHF Bd Only)
C352	2113741N69	0.1µF
C353	2113740B13	3.3pF
C354, 355	2113741N69	0.1µF
C357	2113740B13	3.3pF
C358	2113741N69	0.1µF
C359	2113740B19	5.6pF
C360	2113741N69	0.1µF
C361, 362	-----	Not Placed
C363	2113740B07	1.8pF (Placed on VHF and 800MHz Bds Only)
C364	2113740B11 or 2113740B19	2.7pF (VHF Bd) 5.6pF (UHF and 800MHz Bds)
C365, 366	2113741N69	0.1µF
C600	2113740B49	100pF
C601	2113740B34	24pF
C604	2113741N21	1000pF
C605	2380090M06	10pF
C606, 607	2311049J26	10pF
C608	2380090M06	10pF
C609	2113741N69	0.1µF

ITEM	MOTOROLA PART NUMBER	DESCRIPTION
C610	2113741N45	.01µF
C611	-----	Not Placed
C612	2113741N69	0.1µF
C613	2113741N45	.01µF
C614	2113740B31	18pF
C615	2113740B39	39pF
C616	2113741N45	.01µF
C617 thru 619	2113741N69	0.1µF
C620	2113741N45	.01µF
C621	2113740B25	10pF
C622	2113741N21	1000pF
C623	0880027B09	100pF
C624	2113741N45	.01µF
C625	2113741D28	0.22µF
C626	2113741N45	.01µF (Placed on UHF Bd Only)
C627 thru 629	2113741N45	.01µF
C630	2113740B76	1500pF
C631	2311049J07	3.3pF
C632	2380090M06	10pF
C633	2311049J26	10pF
C634	2113740B76	1500pF
C635	2380090M06	10pF
C636	2380090M07	47pF
C637	2113741N69	0.1µF
C638	2113741N45	.01µF
C639	2113741N69	0.1µF
C641	2113740B01	1.0pF
C642	2113741N69	0.1µF
C644	2113741N69	0.1µF
C645	2113741N45	.01µF
C646	2311049A37	1.0µF
C647	2113741N69	0.1µF
C648 thru 650	-----	Not Placed
C651	2113740B49	100pF
C652	2113740B49	100pF (Placed on UHF Bd Only)
C653	2113740B49	100pF
C654	2113741N45	.01µF (VHF and 800MHz Bds) or ----- Not Placed (UHF Bd)
C656	2113741N69	0.1µF
C657	2113740B27	12pF
C658	2113741N45	.01µF
C659	2113740B27	12pF
C660	2113741N69	0.1µF
C664	2113741N45	.01µF
C665	2113740B27	12pF
C670	2113740B79	2000pF (Placed on VHF Bd Only)
CR301	4880006E09	DIODE: See Note 1. Varactor
CR350	4880140L20	(Placed on UHF Bd Only)
CR352	4880154K03	Dual; Schottky (Placed on VHF Bd Only)
CR353	4880154K03	Dual; Schottky
CR601	4880006E09	Varactor
CR602, 603	4811058B11	
CR605	-----	Not Placed
CR606	4813830A28	
E301	2680006M02	CORE: Ferrite Bead
E302	2680004M03	Ferrite Bead

ITEM	MOTOROLA PART NUMBER	DESCRIPTION
E303	2605261V01	Ferrite Bead (Placed on 800MHz Bd Only)
E602	2680006M02	Ferrite Bead
FL300, 301	9185128U02	FILTER: See Note 2. LC; 450kHz
FL350, 351	4885230C01	Crystal, 109.65 MHz
J350	0980110M01	JACK: Receptacle, Coaxial
J500	0980104M02	Receptacle, Bottom-Entry
J601	0980103N02	Sockets, 12-Position
J602	-----	Not Placed
JU300, 301	0611077A01	JUMPER: 0Ω
JU351	0611077A01	0Ω (Placed on VHF and 800MHz Bds Only)
JU352	0611077A01	0Ω (Placed on UHF Bd Only)
JU601	0611077A01	0Ω
JU604	-----	Not Placed
JU605	0611077A01	0Ω (Placed on UHF and 800MHz Bds Only)
JU606	0611077A01	0Ω (Placed on UHF Bd Only)
JU607	0611077A01	0Ω (Placed on VHF and 800MHz Bds Only)
JU608	0611077A01	0Ω (Placed on UHF Bd Only)
JU609	0611077A01	0Ω (Placed on VHF and 800MHz Bds Only)
JU611	-----	Not Placed
JU612	0611077A01	0Ω (Placed on VHF Bd Only)
JU613	0611077A01	0Ω (Placed on UHF Bd Only)
JU614	0611077A01	0Ω (Placed on 800MHz Bd Only)
JU615	-----	Not Placed
JU617	0611077A01	0Ω (Placed on VHF Bd Only)
JU618	0611077A01	0Ω (Placed on UHF Bd Only)
JU619	0611077A01	0Ω (Placed on 800MHz Bd Only)
JU620	-----	Not Placed
L302	-----	COIL, RF: unless otherwise stated Not Placed
L303	2411087A32	3.3µH
L304	2480140E16	10µH
L350	2405423A12	470nH
L351	2405423A11 or 2405452C90	390nH (VHF and UHF Bds) 400nH (800MHz Bd)
L352	2405423A12	470nH
L353	2405423A11 or 2405423A12	390nH (VHF Bd) 470nH (UHF and 800MHz Bds)
L354	2480140E16	10µH
L600	2480140E06	130nH
L603	-----	Not Placed
L604	2480140E01	1.2µH
L605	-----	Not Placed
L608	2480140E16	10µH
L610, 611	2480140E01	1.2µH
Q350	4802000P02	TRANSISTOR: See Note 1. NPN
Q351	4880052M01	NPN; Darlington (Placed on UHF Bd Only)
Q352	4884235R02	SOT (Placed on UHF Bd Only)

ITEM	MOTOROLA PART NUMBER	DESCRIPTION
Q353	4880048M01	NPN (Placed on UHF Bd Only)
Q354	4802000P02	NPN
Q602, 603	4805128M27	SOT89
Q606	4884235R02	SOT
Q607	4880182D48	PNP
Q608	4880141L01	PNP; SOT23
Q609, 610	4880141L02	NPN; SOT23
Q670	4805218N11	SOT (Placed on VHF Bd Only)
R300	0611077A98	RESISTOR: Ohms ±5%; 1/8W unless otherwise stated
R301	0611077A19	10k
R302	0611077A36	5.1
R303	0611077B33	27
R307, 308	0611077A46	270k
R311	0611077A01	68
R312	0611077A01	0
R313	0611077A01	0 (Placed on UHF and 800MHz Bds Only)
R314	0611077A38 or 0611077A74	33 (VHF Bd) 1k (UHF and 800MHz Bds)
R315	0611077B09	27k
R316	0611077A98	10k
R317	0611077A94	6.8k
R318	0611077A43	51
R319	0611077A01	0
R320	-----	Not Placed
R325	0611077A26	10
R350	-----	Not Placed
R355	0611077A58	220
R356	0611077A36	27
R357	0611077A78	1.5k
R358	0611077A28	12
R359	0611077A01	0 (VHF and 800MHz Bds)
R360	0611077A98 or 0611077A58	10k (UHF Bd) 220 (VHF Bd)
R361	0611077A58	220 (VHF Bd)
R362	0611077A52	120 (UHF and 800MHz Bds)
R363	0611077A32	18 (VHF Bd)
R364	0611077A36	27 (UHF and 800MHz Bds)
R365	0611077A78	1.5k
R366	0611077A28	12
R602	0611077A36	27
R607	0611077A43	51
R608	0611077A74	1k
R609	0611077A98	10k
R610	0611077A62	330
R611	0611077A43	51
R612	0611077B31	220k
R613	0611077B11	220k (Placed on UHF Bd only)
R614	0611077B11	33k
R615	0611077A90	4.7k
R616	0611077B47	1M
R617	0611077B07	22k (VHF Bd)
R618	0611077A98 or 0611077A98	10k (UHF and 800MHz Bds)
R619	0611077B11	33k
R620	0611077A28	12
R621	0611077A74	1k
R622	0611077A74	1k

ITEM	MOTOROLA PART NUMBER	DESCRIPTION
R623	0611077A26	10
R624	0611077A98 or 0611077A90	10k (VHF Bd) 4.7k (UHF and 800MHz Bds)
R625	0611077B01 or 0611077A78	12k (VHF Bd) 1.5k (UHF and 800MHz Bds)
R626	0611077B23	100k
R627	0611077A94 or 0611077A80	6.8k (VHF Bd) 1.8 (UHF and 800MHz Bds)
R628 thru 630	0611077A78	1.5k
R631	0611077B47	1M
R633	0611077B21	82k
R634	1880273N01	Potentiometer
R635	0611077B23	100k
R637	0611077B47	1M
R638, 639	0611077A98	10k
R640	0611077B47	1M (Placed on VHF and 800MHz Bds Only)
R641	0611077A43	51
R642	0611077A98	10k
R645	0611077B47	1M
R646, 647	0611077A98	10k
R653	0611077B11	33k
R670	0611077A90	4.7k (Placed on VHF Bd Only) : :
RT612	0680149M02	THERMISTOR: 100k (Placed on UHF and 800MHz Bds Only) INTEGRATED CIRCUIT MODULE: See Note 1.
U301	5105835U90	Hybrid, ABACUS (VHF and 800MHz Bds)
U302	5105469E90	5V Regulator
U600	5180291B11	Reference Oscillator; 16.8MHz
U601	5180057S09	Prescaler
U602	5180057S10	Synthesizer (Placed on VHF and 800MHz Bds Only)
VR350, 351	4882958R39	DIODE: Zener, 3.3V
Y350	9180084M01	CRYSTAL: See Note 2. 109.65MHz
	2605256X01	Shield, Filter
	7580094M06	Pad, VF Shock
	8485219C02	Circuit Board

Notes:

- For optimum performance, order replacement diodes, transistors, and circuit modules by Motorola part number only.
- When ordering crystals, specify carrier frequency, crystal frequency, crystal type number, and Motorola part number.
- Part value notations:
 $p=10^{-12}$ $m=10^{-3}$
 $n=10^{-9}$ $k=10^3$
 $\mu=10^{-6}$ $M=10^6$
- ITEM refers to the component reference designator.

- The RF Board Kits use a 6-layer printed circuit board.

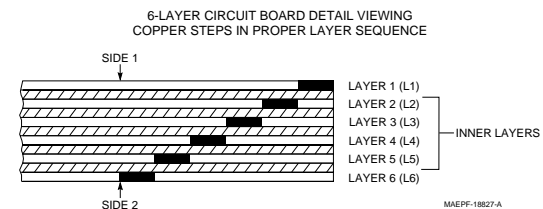

- C334 is Not Placed in the following kits. Earlier kits contain the 100pF capacitor.
HRN4009F,G
HRN6014E-G
HRN4010E,F
HRN6020D-F
HRN6019D-F.

7.3 Command Board Section

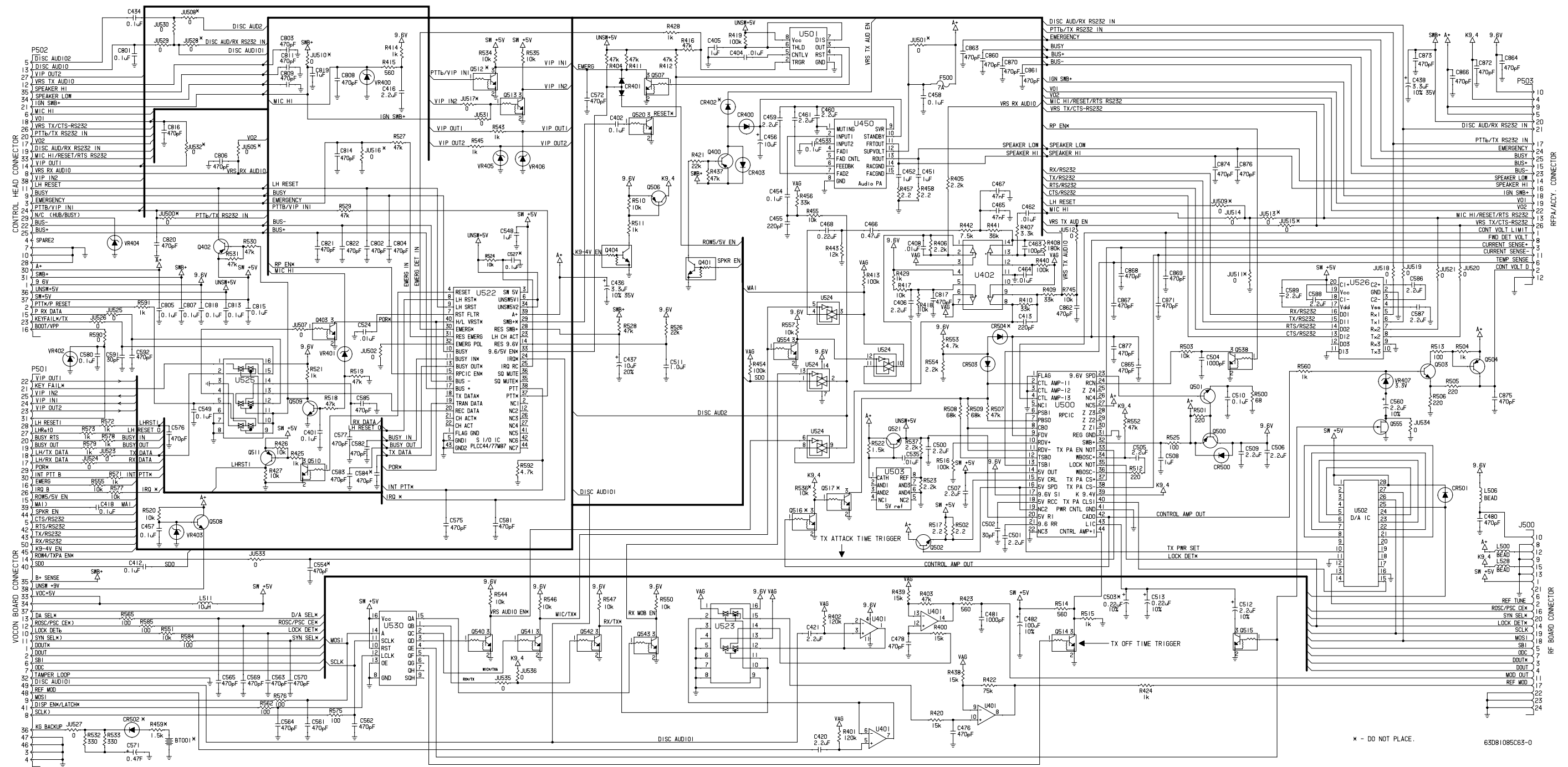

HLN5558E/F/G, HLN6529C/D/E/F/G, HLN6560C/D/E/F/G/H, and HLN6562C/D/E/F/G/H Command Board Schematic Diagram

VIEWED FROM SIDE 1

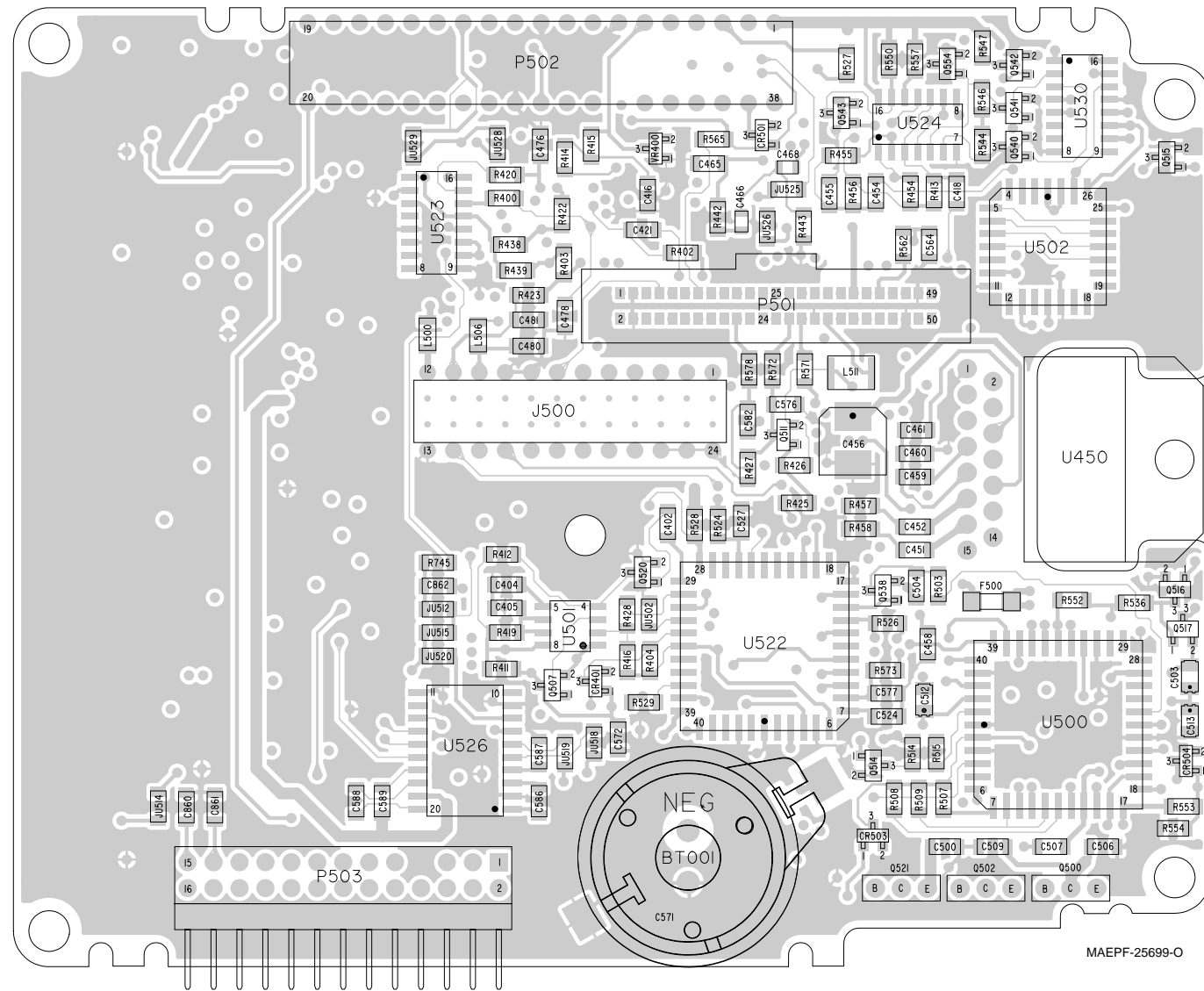

VIEWED FROM SIDE 2

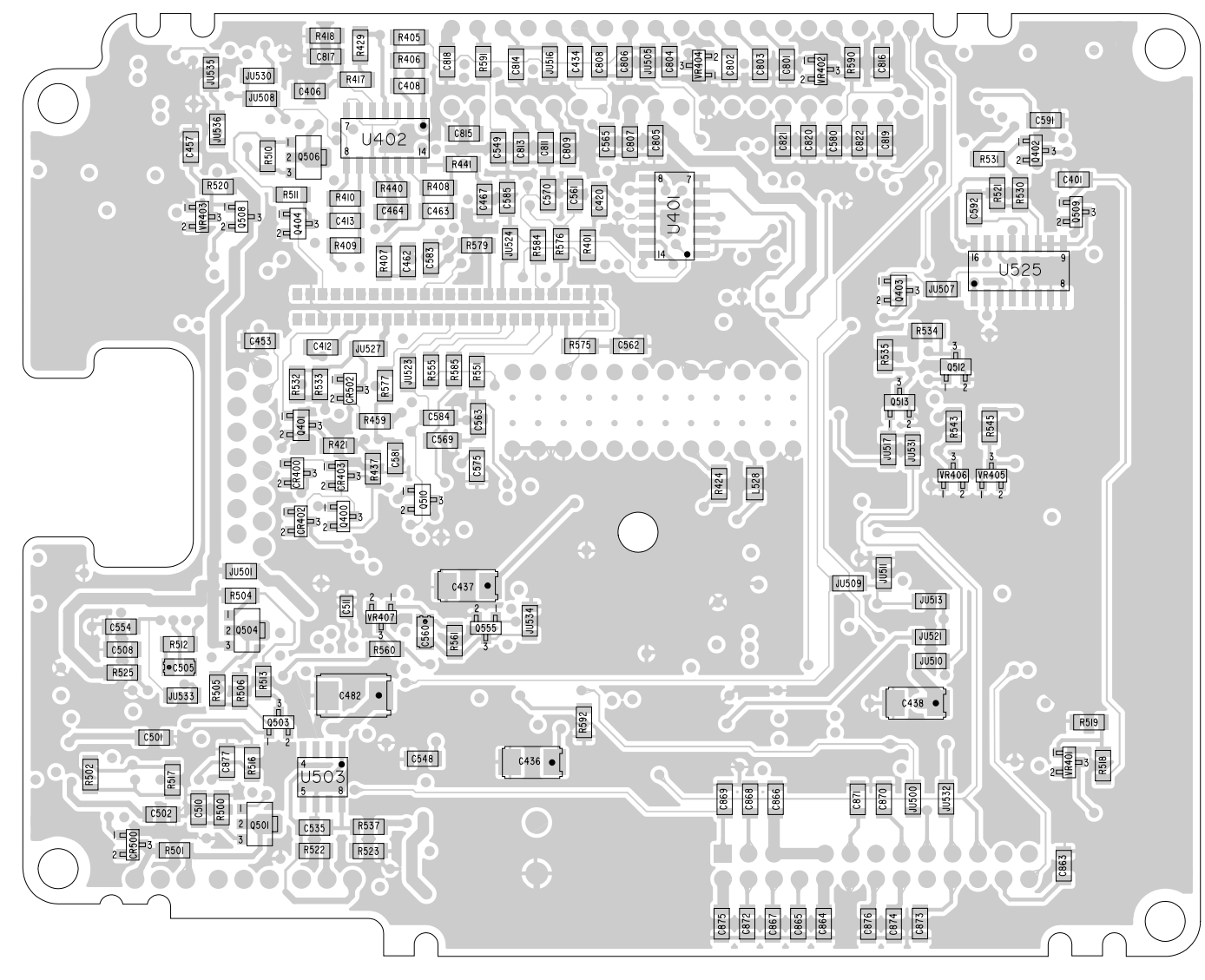

HLN5558E/F/G, HLN6529C/D/E, HLN6560C/D/E/F/G/H, and HLN6562C/D/E/F/G/H Command Board Component Location Diagrams

Command Boards Reference Designator and Part Number Comparison Chart

The following table lists those reference designators common to the various command board kits and the part numbers assigned to those designators for each kit and version.

Ref Des	HLN5558G Part Number	HLN6529G Part Number	HLN6560H Part Number	HLN6562H Part Number
C512	2311049A40	2311049A40	2311049A54	2311049A40
C562	2113740B65	2113740B65	NOTPLACED	NOTPLACED
C571	2105285X01	NOTPLACED	2105285X01	2105285X01
JU500	NOTPLACED	NOTPLACED	0611077A01	0611077A01
JU513	NOTPLACED	NOTPLACED	0611077A01	0611077A01
JU518	0611077A01	0611077A01	NOTPLACED	NOTPLACED
JU519	0611077A01	0611077A01	NOTPLACED	0611077A01
JU521	0611077A01	0611077A01	NOTPLACED	NOTPLACED
JU528	NOTPLACED	NOTPLACED	0611077A01	NOTPLACED
JU532	NOTPLACED	NOTPLACED	NOTPLACED	0611077A01
R561	0611077B29	NOTPLACED	0611077B29	NOTPLACED

HLN5558E/F/G, HLN6529C/D/E, HLN6560C/D/E/F/G/H, and HLN6562C/D/E/F/G/H Parts List

ITEM	MOTOROLA PART NUMBER	DESCRIPTION
C401, 402	2113741N69	0.1µF
C404	2113741N45	.01µF
C405	2113743G21	1µF
C406	2113743G24	2.2µF
C408	2113741N45	.01µF
C412	2113741N69	0.1µF
C413	2113740B57	220pF
C416	2113743G24	2.2µF
C418	2113741N69	0.1µF
C420, 421	2113743G24	2.2µF
C434	2113741N69	0.1µF
C436	2311049J09	3.3µF
C437	2311049J26	10µF
C438	2311049J09	3.3µF
C451, 452	2113743G21	1µF
C453, 454	2113741N69	0.1µF
C455	2113740B57	220pF
C456	2380090M24	10µF
C457, 458	2113741N69	0.1µF
C459 thru 461	2113743G24	2.2µF
C462	2113741B51	.018µF (HLN5558F/G and HLN6529D/E)
	or 2113741N45	.01µF (HLN5558E and HLN6529C)
C463	2113740B49	100pF (HLN5558E and HLN6529C)

ITEM	MOTOROLA PART NUMBER	DESCRIPTION
	or 2113740B59	270pF (HLN5558F/G and HLN6529D/E)
C464	2113741N45	.01µF
C465	2113741B61	.047µF (not placed on HLN5558F/G and HLN6529D/E)
C466	2113743F14	0.47µF
C467	2113741B61	.047µF (Not placed on HLN5558F/G and HLN6529D/E)
C468	2113743F08	0.22µF
C476	2113740B65	470pF
C478	2113740B65	470pF
C480	2113740B65	470pF
C481	2113741N21	1000pF
C482	2311049C07	100µF
C500, 501	2113743G24	2.2µF
C502	2113740B36	30pF
C503	2113743G21	1µF (Not placed on HLN5558F/G and HLN6529E)
C504	2113741N21	1000pF
C505	2311049A40	3.3µF
C506, 507	2113743G24	2.2µF
C508	2113743G21	1µF
C509	2113743G24	2.2µF
C510	2113741N69	0.1µF
C511	2113743F16	1µF
C512	2311049A40	3.3µF
C513	2311049A03	0.22µF
C524	2113741N45	.01µF
C527	2113741N69	0.1µF
C535	2113741N45	.01µF
C548	2113743G21	1µF

ITEM	MOTOROLA PART NUMBER	DESCRIPTION
C549	2113741N69	0.1µF
C554	2113740B65	470pF
C560	2311049A40	2.2µF
C561 thru 565	2113740B65	470pF
C569, 570	2113740B65	470pF
C571	2105285X01	0.47F (Not placed on HLN6529C/D/E)
C572	2113740B65	470pF
C575 thru 577	2113740B65	470pF
C580	2113741N69	0.1µF
C581 thru 583	2113740B65	470pF
C584	-----	Not Placed
C585	2113740B65	470pF
C586 thru 589	2113743G24	2.2µF
C591	2113740B36	30pF
C592	2113740B65	470pF
C801	2113741N69	0.1µF
C802 thru 804	2113740B65	470pF
C805	2113741N69	0.1µF
C806	2113740B65	470pF
C807	2113741N69	0.1µF
C808, 809	2113740B65	470pF
C811	2113740B65	470pF
C813	2113741N69	0.1µF
C814	2113740B65	470pF
C815	2113741N69	0.1µF
C816, 817	2113740B65	470pF
C818	2113741N69	0.1µF
C819	2113743G21	1µF
C820 thru 822	2113740B65	470pF
C860 thru 877	2113740B65	470pF

ITEM	MOTOROLA PART NUMBER	DESCRIPTION
CR400	4813833C10	DIODE: See Note 1. Dual Not Placed
CR401	4813833C03	
CR402	-----	
CR403	4813833C10	
CR500, 501	4813833C10	
CR502	-----	Not Placed
CR503	4813833C10	Not Placed
CR504	-----	
F500	6505663R06	FUSE: 7A
J500	0980104M02	JACK: Receptacle, Bottom Entry
JU500, 501	-----	JUMPER: Not Placed Not Placed Not Placed 0Ω Not Placed 0Ω Not Placed 0Ω Not Placed 0Ω Not Placed 0Ω
JU505	-----	
JU508 thru 511	-----	
JU512	0611077A01	
JU513	-----	
JU514	0611077A01	
JU515 thru 517	-----	
JU518 thru 521	0611077A01	
JU523 thru 527	0611077A01	
JU528	-----	
JU529 thru 531	0611077A01	
JU532	-----	
JU533	0611077A01	

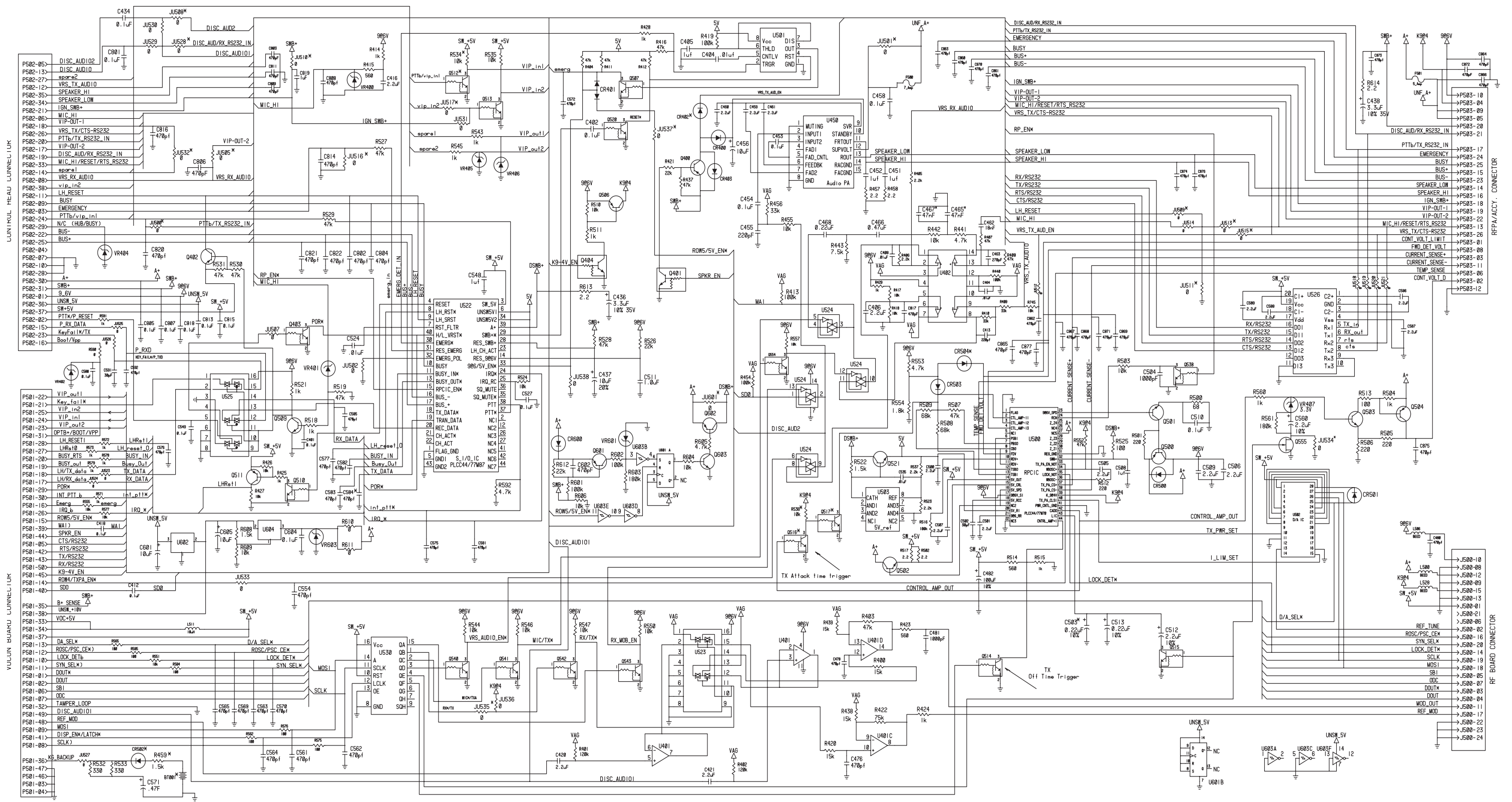

HLN5558H/J, HLN6529H, HLN6560J, and HLN6562J Command Board Schematic Diagram

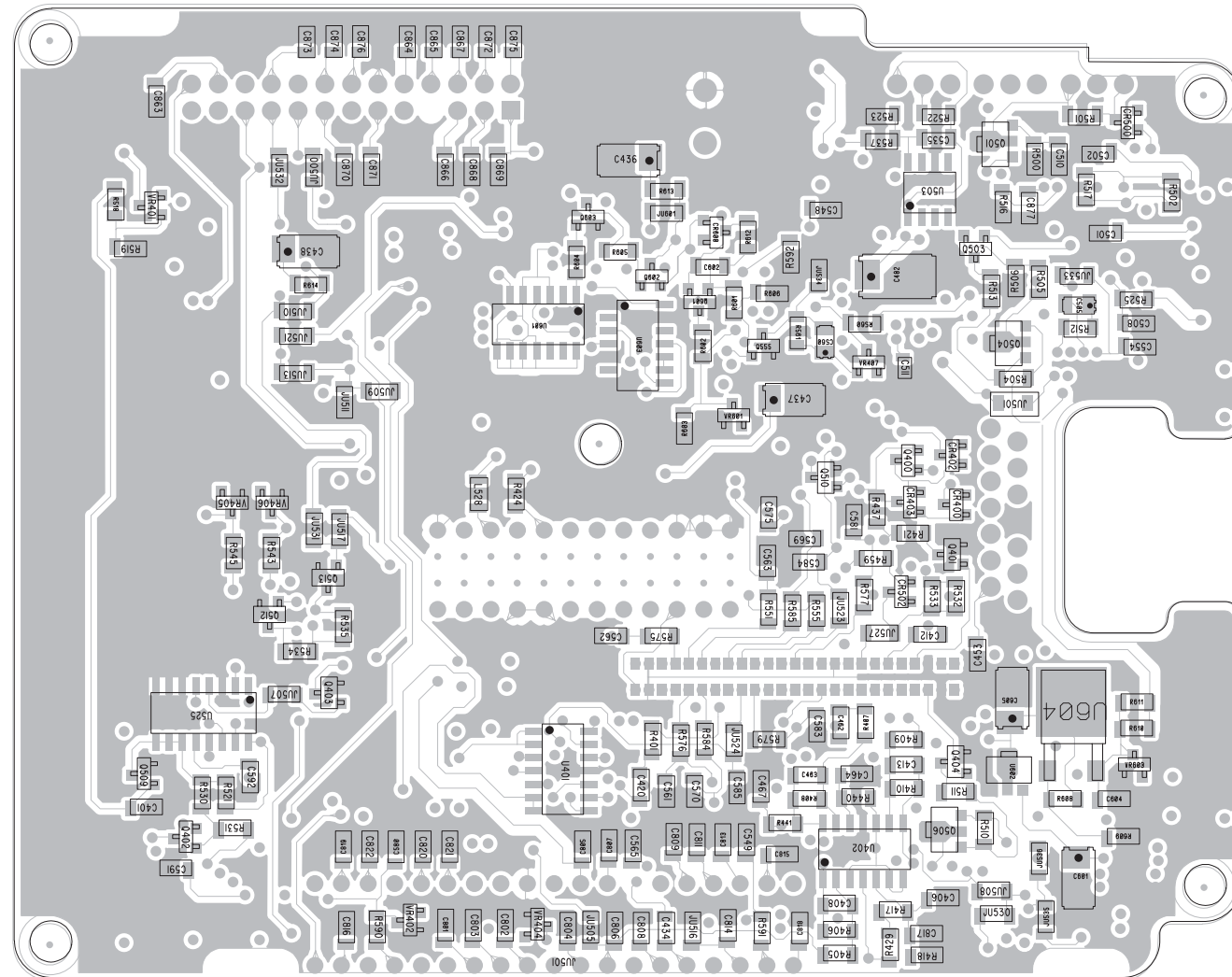

side 1

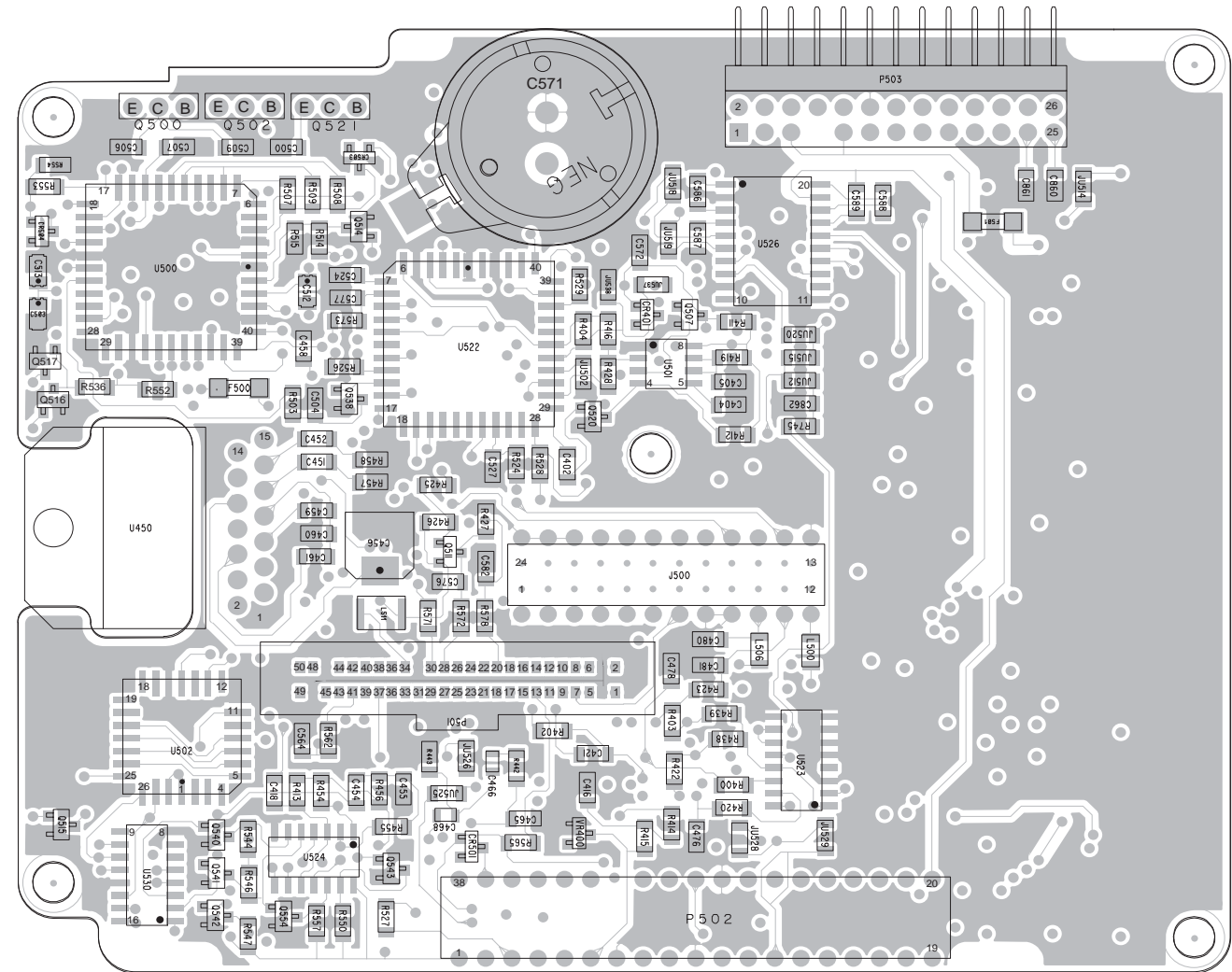

side 2

HLN5558H/J, HLN6529H, HLN6560J, and HLN6562J Component Location Diagram

Command Boards Reference Designator and Part Number Comparison Chart

The following table lists those reference designators common to the various command board kits and the part numbers assigned to those designators for each kit and version.

Ref Des	HLN5558J Part Number	HLN6529H Part Number	HLN6560J Part Number	HLN6562J Part Number
C571	2105285X01	NOTPLACED	2105285X01	2105285X01
JU500	NOTPLACED	NOTPLACED	0611077A01	0611077A01
JU513	NOTPLACED	NOTPLACED	0611077A01	0611077A01
JU518	0611077A01	0611077A01	NOTPLACED	NOTPLACED
JU519	0611077A01	0611077A01	NOTPLACED	0611077A01
JU521	0611077A01	0611077A01	NOTPLACED	NOTPLACED
JU528	NOTPLACED	NOTPLACED	0611077A01	NOTPLACED
JU532	NOTPLACED	NOTPLACED	NOTPLACED	0611077A01

HLN5558H/J, HLN6529H, HLN6560J, and HLN6562J Parts List

ITEM	MOTOROLA PART NUMBER	DESCRIPTION
BT001	-----	NOTPLACED
C401	2113741N69	CAP CHIP CL2 X7R 10% 100000
C402	2113741N69	CAP CHIP CL2 X7R 10% 100000
C404	2113741N45	CAP CHIP CL2 X7R 10% 10000
C405	2113743G21	CER CHIP CAP 1.0 UF
C406	2113743G24	CAP CHIP 2.2 UF 16V +80- 20%
C408	2113741N45	CAP CHIP CL2 X7R 10% 10000
C412	2113741N69	CAP CHIP CL2 X7R 10% 100000
C413	2113740B57	CAP CHIP REEL CL1 +/-30 220
C416	2113743G24	CAP CHIP 2.2 UF 16V +80- 20%
C418	2113741N69	CAP CHIP CL2 X7R 10% 100000
C420	2113743G24	CAP CHIP 2.2 UF 16V +80- 20%
C421	2113743G24	CAP CHIP 2.2 UF 16V +80- 20%
C434	2113741N69	CAP CHIP CL2 X7R 10% 100000
C436	2311049J09	CAP TANT CHIP 3.3 10 35
C437	2311049J26	CAP TANT CHIP 10 20 16

ITEM	MOTOROLA PART NUMBER	DESCRIPTION
C438	2311049J09	CAP TANT CHIP 3.3 10 35
C451 & C452	2113743G21	CER CHIP CAP 1.0 UF
C453	2113741N69	CAP CHIP CL2 X7R 10% 100000
C454	2113741N69	CAP CHIP CL2 X7R 10% 100000
C455	2113740B57	CAP CHIP REEL CL1 +/-30 220
C456	2380090M24	CAP ALU 10 20 50V SURF MT
C458	2113741N69	CAP CHIP CL2 X7R 10% 100000
C459 thru C461	2113743G24	CAP CHIP 2.2 UF 16V +80- 20%
C462	2113741B51	CAP CHIP CL2 X7R REEL 18000
C463	2113740B59	CAP CHIP REEL CL1 +/-30 270
C464	2113741N45	CAP CHIP CL2 X7R 10% 10000
C465	-----	NOTPLACED
C466	2113743F14	CAP CHIP .470UF +80 - 20% Y5V
C467	-----	NOTPLACED
C468	2113743F08	CER CHIP CAP .220UF
C476, C478 & C480	2113740B65	CAP CHIP REEL CL1 +/-30 470
C481	2113741N21	CAP CHIP CL2 X7R 10% 1000
C482	2311049A28	CAP TANT CHIP 100UF 6V

ITEM	MOTOROLA PART NUMBER	DESCRIPTION
C500 & C501	2113743G24	CAP CHIP 2.2 UF 16V +80- 20%
C502	2113740B36	CAP CHIP REEL CL1 +/-30 30
C503	-----	NOTPLACED
C504	2113741N21	CAP CHIP CL2 X7R 10% 1000
C505	2311049A40	CAP TANT CHIP 2.2 10 10
C506 & C507	2113743G24	CAP CHIP 2.2 UF 16V +80- 20%
C508	2113743G21	CER CHIP CAP 1.0 UF
C509	2113743G24	CAP CHIP 2.2 UF 16V +80- 20%
C510	2113741N69	CAP CHIP CL2 X7R 10% 100000
C511	2113743F16	CAP CHIP 1.0 UF 16V +80- 20%
C512	2311049A40	CAP TANT CHIP 2.2 10 10
C513	2311049A03	CAP TANT CHIP A/P .22 10 35
C524	2113741N45	CAP CHIP CL2 X7R 10% 10000
C527	2113741N69	CAP CHIP CL2 X7R 10% 100000
C535	2113741N45	CAP CHIP CL2 X7R 10% 10000
C548	2113743G21	CER CHIP CAP 1.0 UF
C549	2113741N69	CAP CHIP CL2 X7R 10% 100000

ITEM	MOTOROLA PART NUMBER	DESCRIPTION
C554	2113740B65	CAP CHIP REEL CL1 +/-30 470
C560	2311049A40	CAP TANT CHIP 2.2 10 10
C561	2113740B65	CAP CHIP REEL CL1 +/-30 470
C562	2113740B65	CAP CHIP REEL CL1 +/-30 470 ^{1 and 5} NOTPLACED ^{2, 3, and 4}
C563	2113740B65	CAP CHIP REEL CL1 +/-30 470
C564	2113740B65	CAP CHIP REEL CL1 +/-30 470
C565	2113740B65	CAP CHIP REEL CL1 +/-30 470
C569	2113740B65	CAP CHIP REEL CL1 +/-30 470
C570	2113740B65	CAP CHIP REEL CL1 +/-30 470
C571	2105285X01	CAP GOLD F SERIES (.47 FARAD) ^{1, 2, 4, and 5} NOT PLACED ³
C572	2113740B65	CAP CHIP REEL CL1 +/-30 470
C575	2113740B65	CAP CHIP REEL CL1 +/-30 470
C576	2113740B65	CAP CHIP REEL CL1 +/-30 470
C577	2113740B65	CAP CHIP REEL CL1 +/-30 470
C580	2113741N69	CAP CHIP CL2 X7R 10% 100000

ITEM	MOTOROLA PART NUMBER	DESCRIPTION
C581	2113740B65	CAP CHIP REEL CL1 +/-30 470
C582	2113740B65	CAP CHIP REEL CL1 +/-30 470
C583	2113740B65	CAP CHIP REEL CL1 +/-30 470
C584	-----	NOTPLACED
C585	2113740B65	CAP CHIP REEL CL1 +/-30 470
C586 thru C589	2113743G24	CAP CHIP 2.2 UF 16V +80-20%
C591	2113740B36	CAP CHIP REEL CL1 +/-30 30
C592	2113740B65	CAP CHIP REEL CL1 +/-30 470
C601	2311049J26	CAP TANT CHIP 10 20 16 2, 3, 4, and 5
C602	2113740B65	CAP CHIP REEL CL1 +/-30 470
C604	2113741N69	CAP CHIP CL2 X7R 10% 100000
C605	2311049J26	CAP TANT CHIP 10 20 16 2, 3, 4, and 5
C801	2113741N69	CAP CHIP CL2 X7R 10% 100000
C802 thru C804	2113740B65	CAP CHIP REEL CL1 +/-30 470
C805	2113741N69	CAP CHIP CL2 X7R 10% 100000
C806	2113740B65	CAP CHIP REEL CL1 +/-30 470
C807	2113741N69	CAP CHIP CL2 X7R 10% 100000
C808, C809 & C811	2113740B65	CAP CHIP REEL CL1 +/-30 470
C813	2113741N69	CAP CHIP CL2 X7R 10% 100000
C814	2113740B65	CAP CHIP REEL CL1 +/-30 470
C815	2113741N69	CAP CHIP CL2 X7R 10% 100000
C816 & C817	2113740B65	CAP CHIP REEL CL1 +/-30 470
C818	2113741N69	CAP CHIP CL2 X7R 10% 100000
C819	2113743G21	CER CHIP CAP 1.0 UF
C820 thru C822	2113740B65	CAP CHIP REEL CL1 +/-30 470
C860 thru C877	2113740B65	CAP CHIP REEL CL1 +/-30 470
CR400	4813833C10	DIODE GEN PUR 70V MMBD6050

ITEM	MOTOROLA PART NUMBER	DESCRIPTION
CR401	4813833C03	DIODE DUAL 70V 'A1X' BAW56LT1
CR402	-----	NOTPLACED
CR403, CR500 & CR501	4813833C10	DIODE GEN PUR 70V MMBD6050
CR502	-----	NOTPLACED
CR503	4813833C10	DIODE GEN PUR 70V MMBD6050
CR504	-----	NOTPLACED
CR600	4813833C10	DIODE GEN PUR 70V MMBD6050
F500	6505663R06	FUSE 7 AMP
F501	6505663R03	FUSE 5 AMP
J500	0980104M02	RECEPTACLE BOTTOM ENTRY
JU500	-----	NOTPLACED ^{1, 2, and 3}
	0611077A01	RES CHIP JUMPER ^{4 and 5}
JU501	-----	NOTPLACED
JU502	0611077A01	RES CHIP JUMPER
JU505	-----	NOTPLACED
JU507	0611077A01	RES CHIP JUMPER
JU508 thru JU511	-----	NOTPLACED
JU512	0611077A01	RES CHIP JUMPER
JU513	-----	NOTPLACED ^{1, 2, and 3}
	0611077A01	RES CHIP JUMPER ^{4 and 5}
JU514	0611077A01	RES CHIP JUMPER
JU515 thru JU517	-----	NOTPLACED
JU518	0611077A01	RES CHIP JUMPER ^{1, 2, and 3}
	-----	NOTPLACED ^{4 and 5}
JU519	0611077A01	RES CHIP JUMPER ^{1, 2, 3, and 5}
	-----	NOTPLACED ⁴
JU520	0611077A01	RES CHIP JUMPER
JU521	0611077A01	RES CHIP JUMPER ^{1, 2, and 3}
	-----	NOTPLACED ^{4 and 5}
JU523 thru JU527	0611077A01	RES CHIP JUMPER
JU528	-----	NOTPLACED ^{1, 2, 3, and 5}
	0611077A01	RES CHIP JUMPER ⁴
JU529 thru JU531	0611077A01	RES CHIP JUMPER
JU532	-----	NOTPLACED
JU533	0611077A01	RES CHIP JUMPER
JU534, JU535	-----	NOTPLACED
JU536	0611077A01	RES CHIP JUMPER
JU537	-----	NOTPLACED
JU538	0611077A01	RES CHIP JUMPER

ITEM	MOTOROLA PART NUMBER	DESCRIPTION
JU601	-----	NOTPLACED
L500 & L506	2480067M01	CHK RF CHIP BEAD INDUCTOR 28MZ
L511	2413924A13	IND CHIP 10.0 UH 10%
L528	2480067M01	CHK RF CHIP BEAD INDUCTOR 28MZ
P501	2805515W01	CONN PLUG
P502	0980103M02	RECEPTACLE RIGHT ANGLE
P503	2880267M01	PLUG RIGHT ANGLE HDR 26 POS
Q400	4880141L01	TSTR PNP SOT23 LO PROFILE TAPE
Q401	4880048M01	TSTR NPN DIG 47K/47K
Q402	4880141L01	TSTR PNP SOT23 LO PROFILE TAPE
Q403 & Q404	4880048M01	TSTR NPN DIG 47K/47K
Q500	4813822D39	TSTR PNP 60V 7A 2N5194
Q501	4880053M02	TSTR NPN MXT2222A
Q502	4880182D46	TSTR NPN 2N5190
Q503	4880141L02	TSTR NPN SOT23 LO PROFILE TAPE
Q504 & Q506	4805128M27	TSTR SOT89 BSR33 LH
Q507	4880048M01	TSTR NPN DIG 47K/47K
Q508	4805218N50	TSTR SOT BCW 60B (RH)
Q509	4805128M12	TSTR SOT BCW 60B (RH)
Q510	4880048M01	TSTR NPN DIG 47K/47K
Q511	4880141L01	TSTR PNP SOT23 LO PROFILE TAPE
Q512	-----	NOTPLACED
Q513 thru Q515	4880048M01	TSTR NPN DIG 47K/47K
Q516 & Q517	-----	NOTPLACED
Q520	4880048M01	TSTR NPN DIG 47K/47K
Q521	4880182D46	TSTR NPN 2N5190
Q538	4880048M01	TSTR NPN DIG 47K/47K
Q540 thru Q543	4880048M01	TSTR NPN DIG 47K/47K
Q554	4880048M01	TSTR NPN DIG 47K/47K
Q555	4805218N11	XISTOR SOT RH BST82
Q601 & Q602	4880141L01	TSTR PNP SOT23 LO PROFILE TAPE
Q603	4805128M12	TSTR SOT BCW 60B (RH) 2, 3, 4, and 5
R400	0611077B03	RES CHIP 15K 5 1/8W
R401 & R402	0611077B25	RES CHIP 120K 5 1/8W
R403 & R404	0611077B15	RES CHIP 47K 5 1/8W
R405 & R406	0611077A82	RES CHIP 2200 5 1/8
R407 & R408	0611077B15	RES CHIP 47K 5 1/8W

ITEM	MOTOROLA PART NUMBER	DESCRIPTION
R409 & R410	0611077B11	RES CHIP 33K 5 1/8W
R411 & R412	0611077B15	RES CHIP 47K 5 1/8W
R413	0611077B23	RES CHIP 100K 5 1/8W
R414	0611077A74	RES CHIP 1000 5 1/8
R415	0611077A68	RES CHIP 560 5 1/8W
R416	0611077B15	RES CHIP 47K 5 1/8W
R417 & R418	0611077A98	RES CHIP 10K 5 1/8W
R419	0611077B23	RES CHIP 100K 5 1/8W
R420	0611077B03	RES CHIP 15K 5 1/8W
R421	0611077B07	RES CHIP 22K 5 1/8W
R422	0611077B20	RES CHIP 75K 5 1/8W
R423	0611077A68	RES CHIP 560 5 1/8W
R424 & R425	0611077A74	RES CHIP 1000 5 1/8
R426 & R427	0611077A98	RES CHIP 10K 5 1/8W
R428 & R429	0611077A74	RES CHIP 1000 5 1/8
R437	0611077B15	RES CHIP 47K 5 1/8W
R438 & R439	0611077B03	RES CHIP 15K 5 1/8W
R440	0611077B23	RES CHIP 100K 5 1/8W
R441	0611077A90	RES CHIP 4700 5 1/8
R442	0611077A98	RES CHIP 10K 5 1/8W
R443	0611077A95	RES CHIP 7500 5 1/8
R454	0611077B23	RES CHIP 100K 5 1/8W
R455	0611077A98	RES CHIP 10K 5 1/8W
R456	0611077B11	RES CHIP 33K 5 1/8W
R457 & R458	0611077A10	RES CHIP 2.2 5 1/8W
R459	-----	NOTPLACED
R500	0611077A46	RES CHIP 68 5 1/8W
R501	0611077A58	RES CHIP 220 5 1/8W
R502	0611077A10	RES CHIP 2.2 5 1/8W
R503	0611077A98	RES CHIP 10K 5 1/8W
R504	0611077A74	RES CHIP 1000 5 1/8
R505 & R506	0611077A58	RES CHIP 220 5 1/8W
R507	0611077B15	RES CHIP 47K 5 1/8W
R508 & R509	0611077B19	RES CHIP 68K 5 1/8W
R510	0611077A98	RES CHIP 10K 5 1/8W
R511	0611077A74	RES CHIP 1000 5 1/8
R512	0611077A58	RES CHIP 220 5 1/8W
R513	0611077A50	RES CHIP 100 5 1/8W
R514	0611077A68	RES CHIP 560 5 1/8W
R515	0611077A74	RES CHIP 1000 5 1/8
R516	0611077B23	RES CHIP 100K 5 1/8W
R517	0611077A10	RES CHIP 2.2 5 1/8W
R518	0611077A74	RES CHIP 1000 5 1/8
R519	0611077B15	RES CHIP 47K 5 1/8W
R521	0611077A74	RES CHIP 1000 5 1/8
R522	0611077A78	RES CHIP 1500 5 1/8
R523	0611077A82	RES CHIP 2200 5 1/8
R524	0611077A98	RES CHIP 10K 5 1/8W
R525	0611077A50	RES CHIP 100 5 1/8W
R526	0611077B07	RES CHIP 22K 5 1/8W
R527	0611077B15	RES CHIP 47K 5 1/8W

ITEM	MOTOROLA PART NUMBER	DESCRIPTION
R528 thru R531	0611077B15	RES CHIP 47K 5 1/8W
R532 & R533	0611077A62	RES CHIP 330 5 1/8W
R534	-----	NOTPLACED
R535	0611077A98	RES CHIP 10K 5 1/8W
R536	-----	NOTPLACED
R537	0611077A82	RES CHIP 2200 5 1/8
R543	0611077A74	RES CHIP 1000 5 1/8
R544	0611077A98	RES CHIP 10K 5 1/8W
R545	0611077A74	RES CHIP 1000 5 1/8
R546 & R547	0611077A98	RES CHIP 10K 5 1/8W
R550 & R551	0611077A98	RES CHIP 10K 5 1/8W
R552	0611077B15	RES CHIP 47K 5 1/8W
R553	0611077A90	RES CHIP 4700 5 1/8
R554	0611077A80	RES CHIP 1800 5 1/8
R555 & R557	0611077A98	RES CHIP 10K 5 1/8W
R560	0611077A74	RES CHIP 1000 5 1/8
R561	0611077B29	RES CHIP 180K 5 1/8W
R562 & R565	0611077A50	RES CHIP 100 5 1/8W
R571 thru R573	0611077A74	RES CHIP 1000 5 1/8
R575 & R576	0611077A50	RES CHIP 100 5 1/8W
R577	0611077A98	RES CHIP 10K 5 1/8W
R578 & R579	0611077A74	RES CHIP 1000 5 1/8
R584 & R585	0611077A50	RES CHIP 100 5 1/8W
R590	0611077A01	RES CHIP JUMPER
R591	0611077A74	RES CHIP 1000 5 1/8
R592	0611077A90	RES CHIP 4700 5 1/8
R601 & R602	0611077B23	RES CHIP 100K 5 1/8W
R603	0611077B29	RES CHIP 180K 5 1/8W
R604	0611077A98	RES CHIP 10K 5 1/8W
R605	0611077A90	RES CHIP 4700 5 1/8
R606	0611077A98	RES CHIP 10K 5 1/8W
R608	0611077A78	RES CHIP 1500 5 1/8
R609	0611077A98	RES CHIP 10K 5 1/8W
R610	-----	NOTPLACED
R611	0611077A01	RES CHIP JUMPER
R612	0611077B07	RES CHIP 22K 5 1/8W
R613 & R614	0611077A10	RES CHIP 2.2 5 1/8W
R745	0611077A98	RES CHIP 10K 5 1/8W
U401 & U402	5183222M49	IC AMP _3403_
U450	5180065C19	IC AUDIO PA 4.5 AMP 22W
U500	5180057S01	IC REG/PWR CONT 13" REEL
U501	5113815G02	IC TIMER 555 1455
U502	5180057S02	IC CMOS CUST DA CONV 13" REEL
U503	5180056M02	IC 2.5V PRGMBLE PREC REF SO 8
U522	5180057S04	IC CUST SER I/O 13" REEL

ITEM	MOTOROLA PART NUMBER	DESCRIPTION
U523	5113806A20	IC MUX/DEMUX,TRIPLE 2-CHNL
U524	5182400T11	IC HCMOS 04M52 QUAD SW
U525	5113806A20	IC MUX/DEMUX,TRIPLE 2-CHNL
U526	5113811A11	IC RS-232-C DVR/RCVR SNGL SUP
U530	5105492X76	IC 8 BIT SHIFT REGISTER
U601	5113806A05	IC FLIP-FLOP,DUAL D
U602	5105625U41	IC +5V REGULATOR
U603	5113806A37	IC SCHMITT TRIGGER,HEX
U604	5113816A19	IC ADJ LO DROPOUT POS REG .8A
VR400	4813830A28	DIODE 15V 5% 225MW MMBZ5245B_
VR401	4813830A24	DIODE 11V 5% 225MW MMBZ5241B_
VR402	4813830A28	DIODE 15V 5% 225MW MMBZ5245B_
VR404 thru VR406	4813830A28	DIODE 15V 5% 225MW MMBZ5245B_
VR407	4805129M27	DIODE MMBZ5226 RH
VR601	4813830A14	DIODE 5.1V 5% 225MW MMBZ5231B_
VR603	-----	NOTPLACED
	8485758A04	BD CKT COMMAND

Notes:

1. Valid in HLN6558H
2. Valid in HLN5558J
3. Valid in HLN6529J
4. Valid in HLN6560J
5. Valid in HLN6562J

7.4 VOCON Section

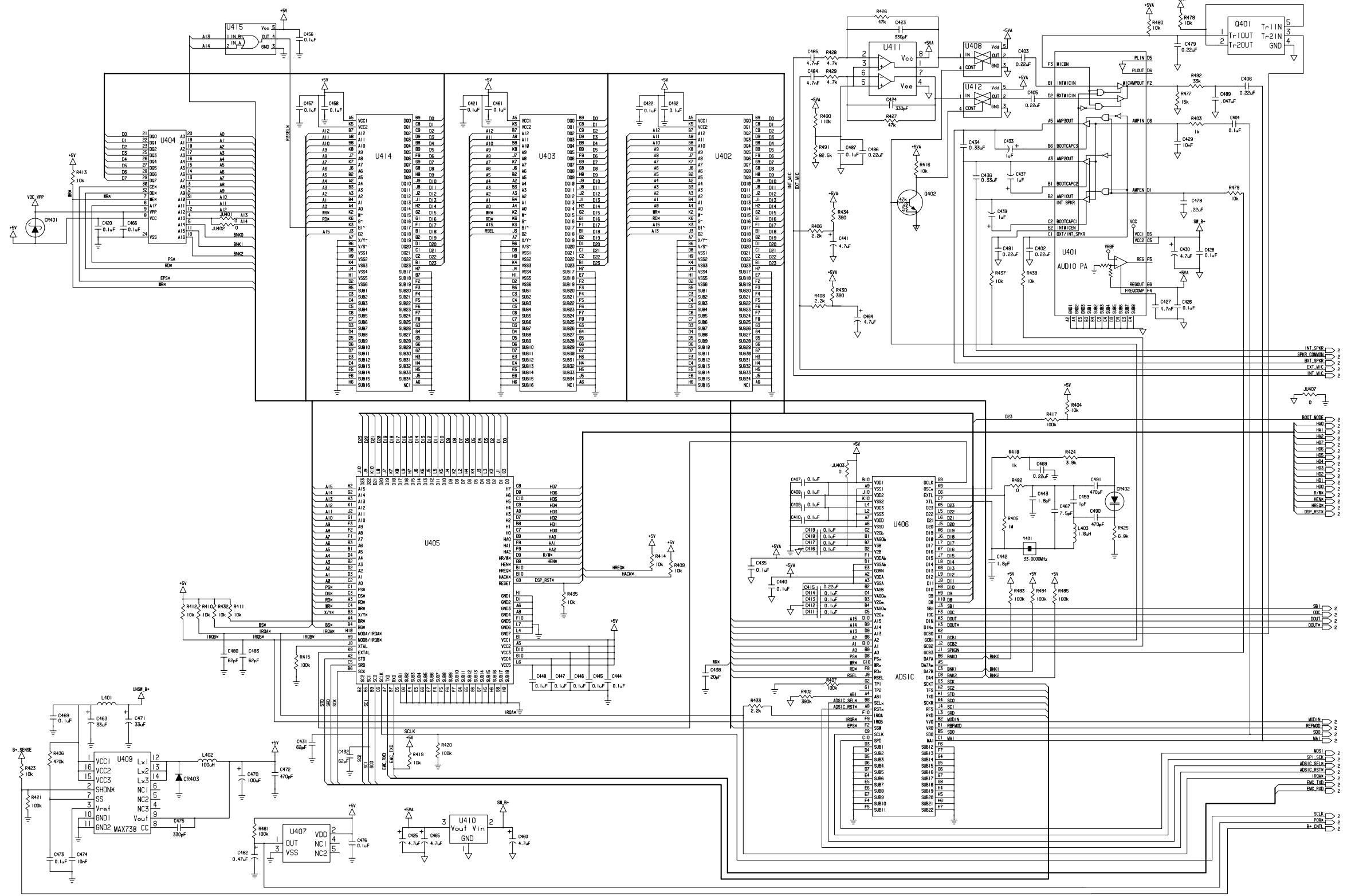

HLN6458D VOCON Board Schematic (Sheet 1 of 2)

6381087C40-0

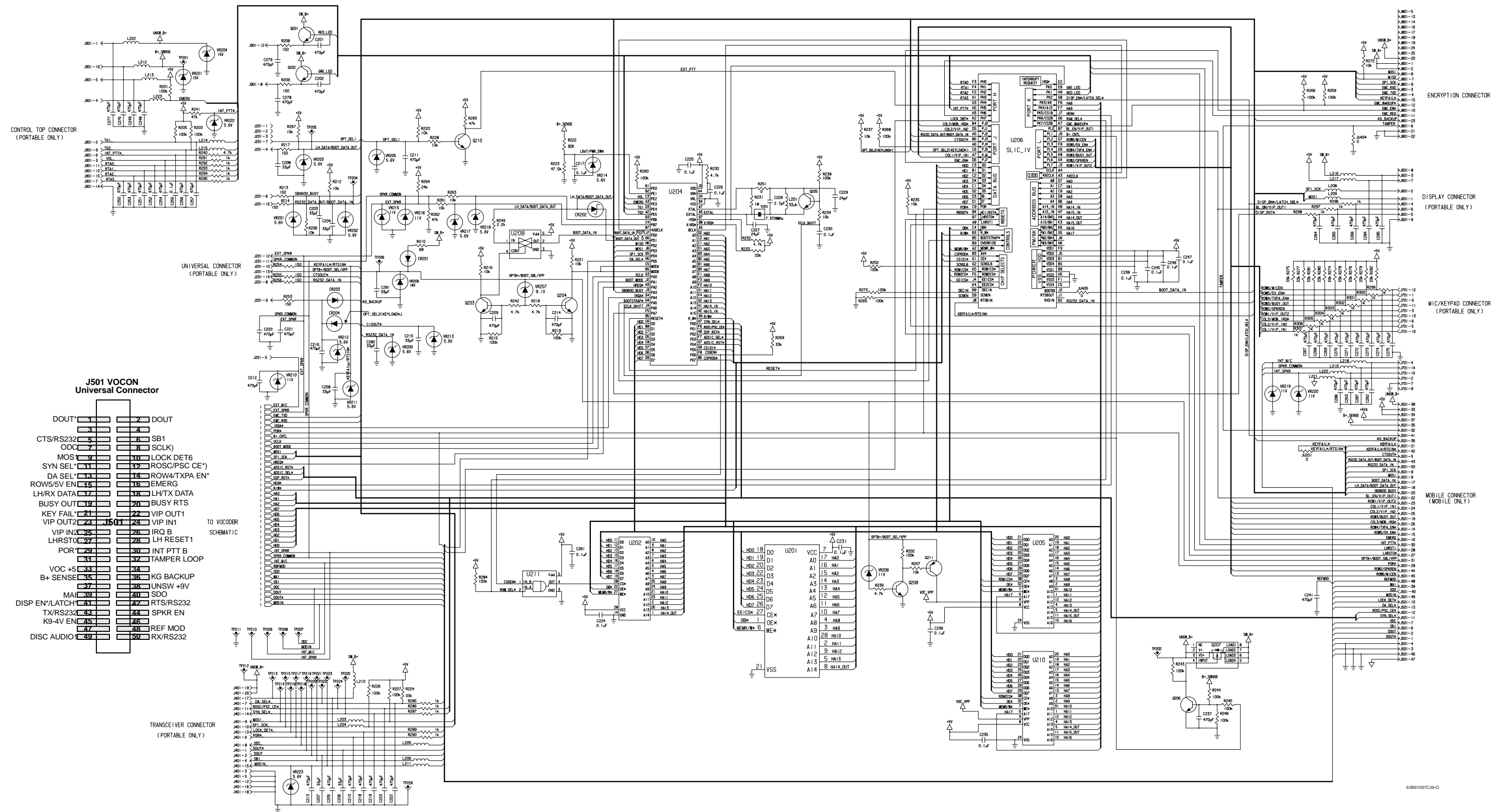

HLN6458D VOCON Board Schematic (Sheet 2 of 2)

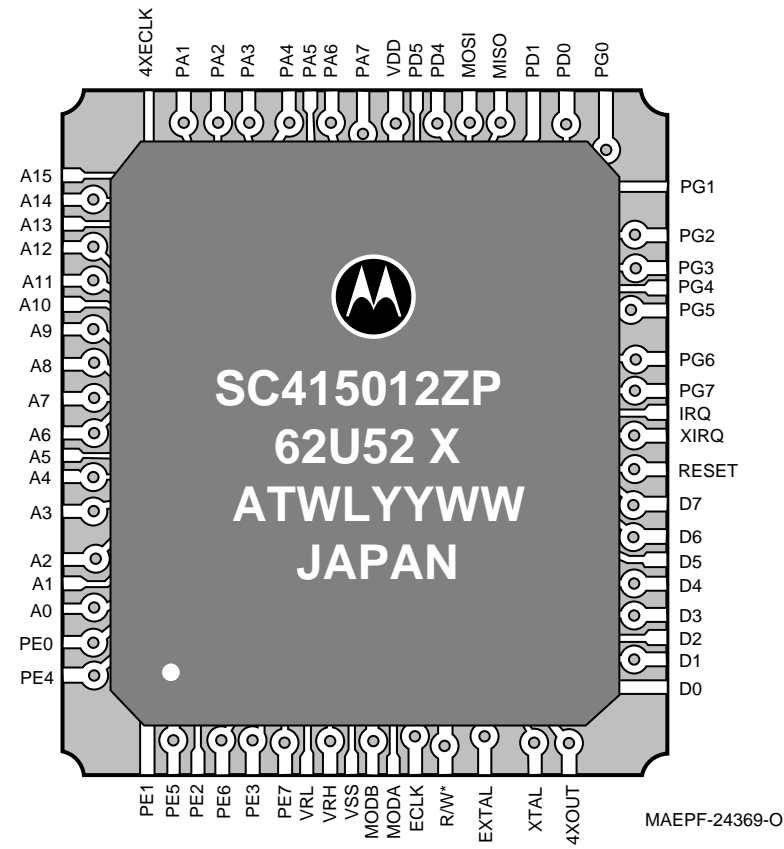

U204 - MCU

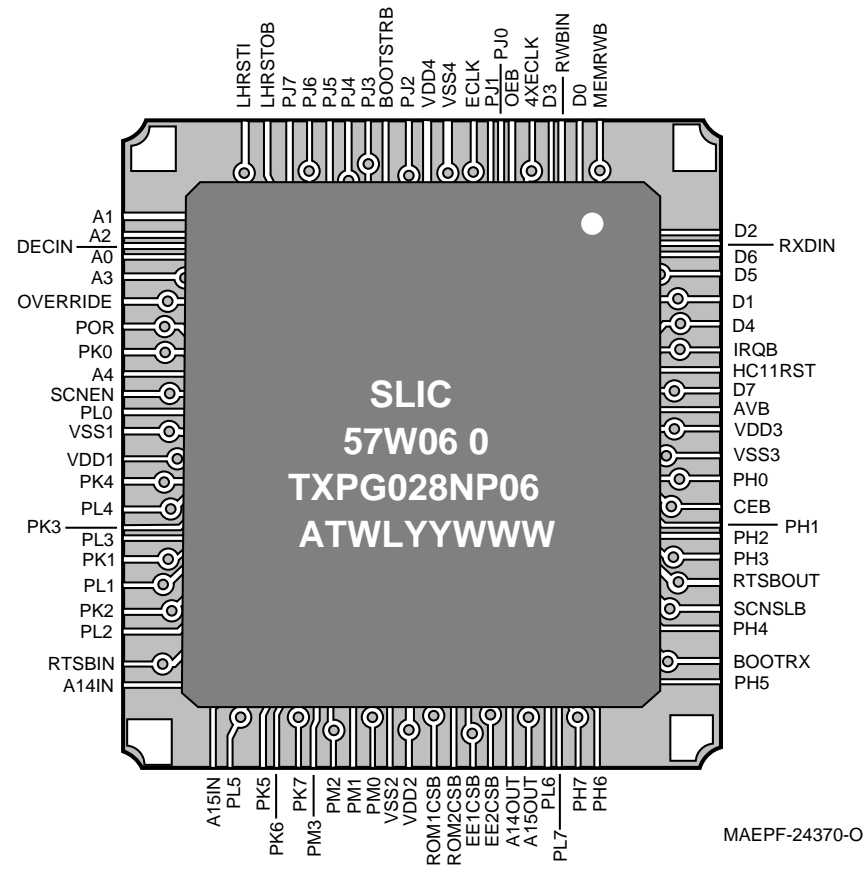

U206 - SLIC

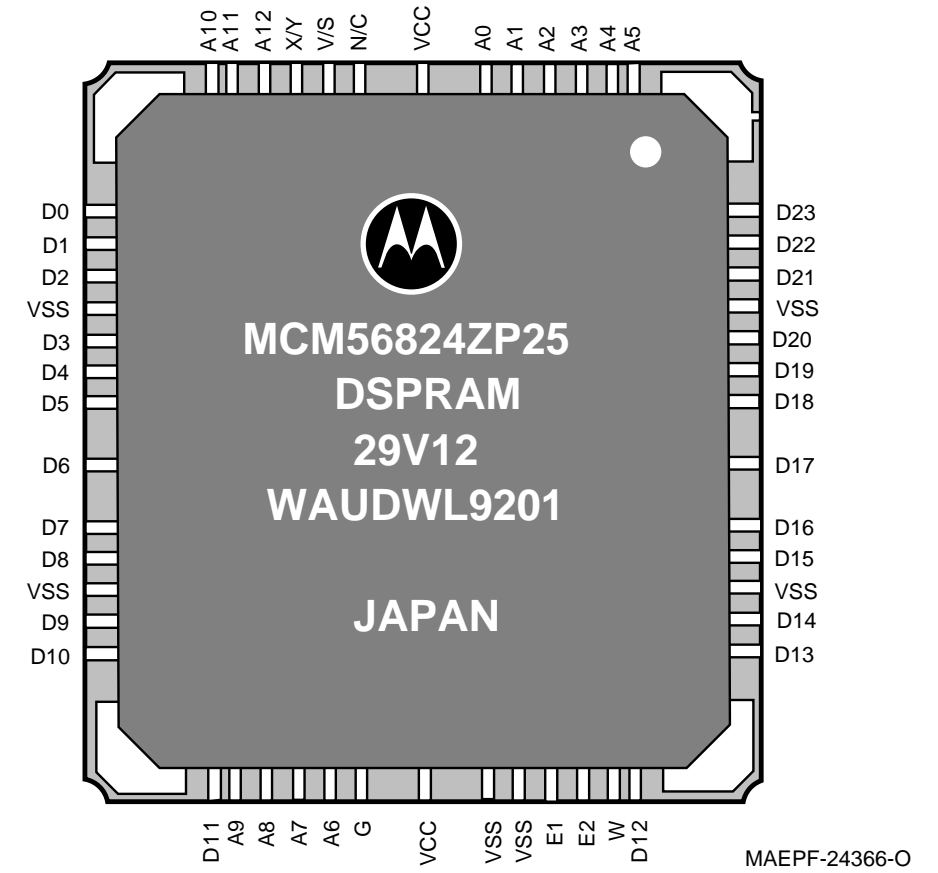

U402, U403, U414 - DSP SRAM

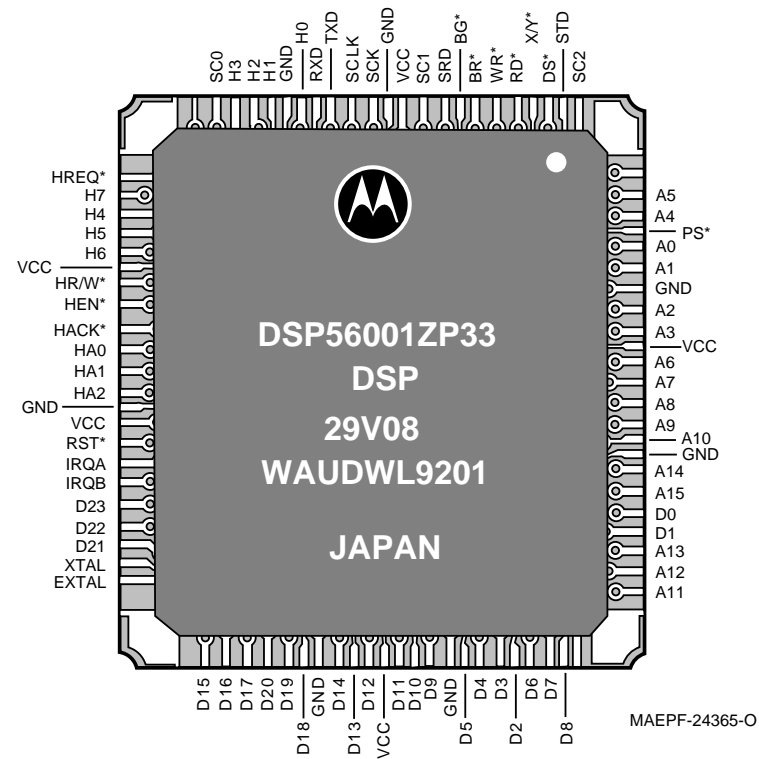

U405 - DSP

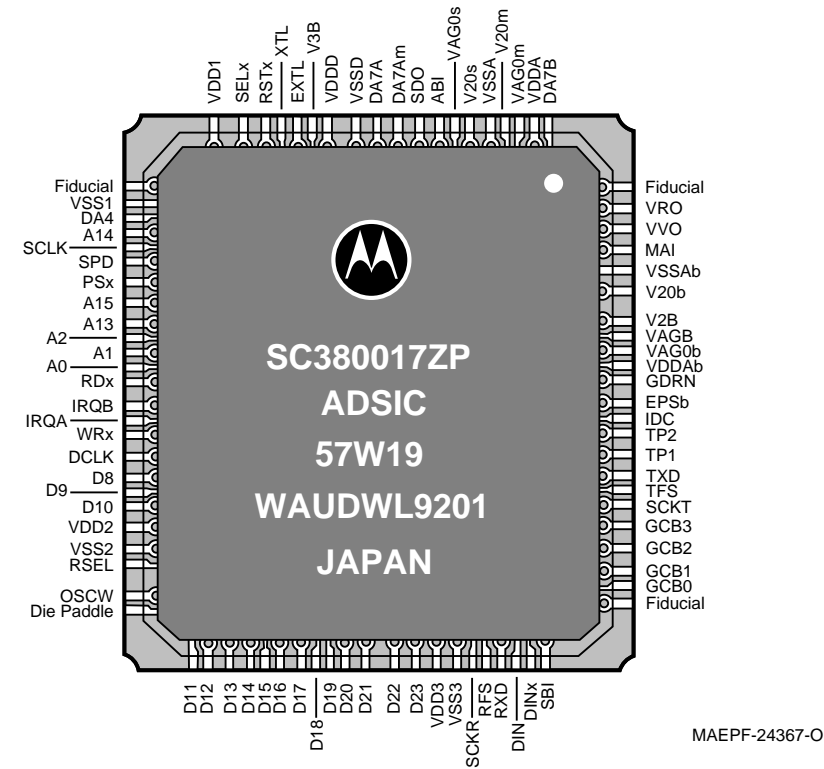

VIEWS FROM SIDE 1

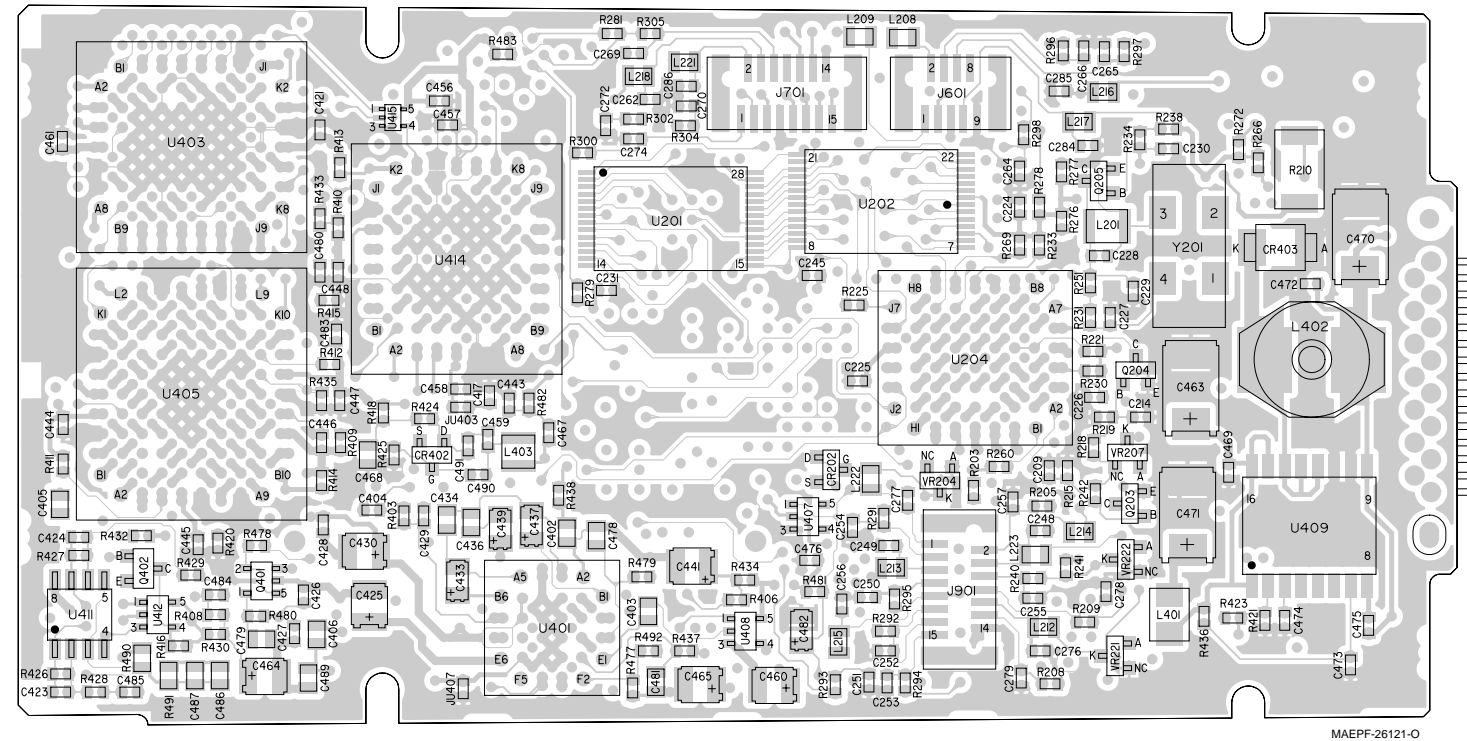

VIEWS FROM SIDE 2

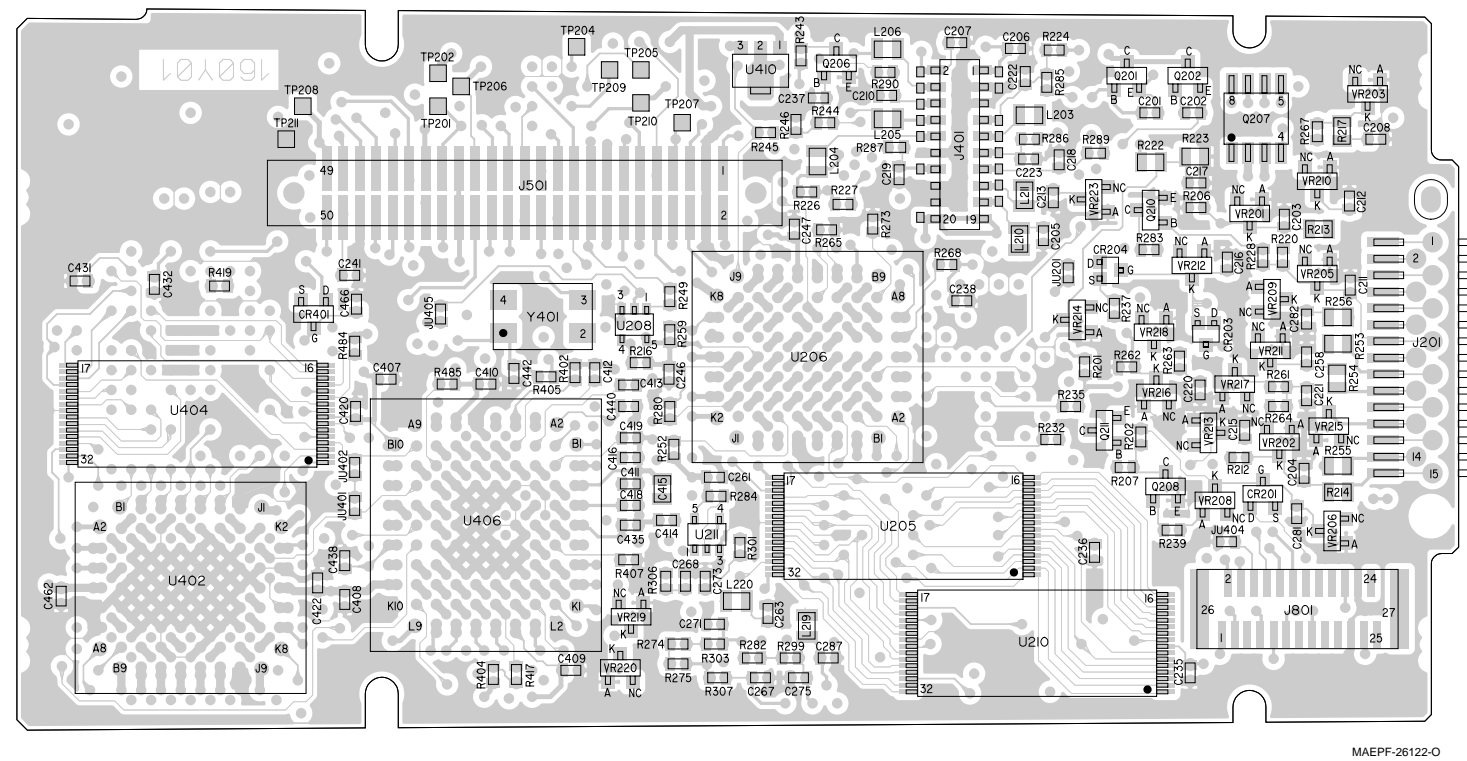

HLN6458D VOCON Board Parts List

ITEM	MOTOROLA PART NUMBER	DESCRIPTION
C201	-----	NOTPLACED
C202	-----	NOTPLACED
C203 & C204	2113930F39	CAP CER CHP 33 PF 50V 5%
C205 thru C213	-----	NOTPLACED
C214	2113931F17	CAP CER CHP 470 PF 5% 50V
C215	2113930F39	CAP CER CHP 33 PF 50V 5%
C216	-----	NOTPLACED
C217	2113932K15	CAP CER .100 UF +80/-20% 16V
C218	-----	NOTPLACED
C219	2113931F17	CAP CER CHP 470 PF 5% 50V
C220 & C221	-----	NOTPLACED
C222 & C223	2113931F17	CAP CER CHP 470 PF 5% 50V
C224 thru C226	2113932K15	CAP CER .100 UF +80/-20% 16V
C227	2113930F36	CAP CER CHP 24 PF 50V 5%
C228	-----	NOTPLACED
C229	2113930F36	CAP CER CHP 24 PF 50V 5%
C230 & C231	2113932K15	CAP CER .100 UF +80/-20% 16V
C235 & C236	2113932K15	CAP CER .100 UF +80/-20% 16V
C237	2113931F17	CAP CER CHP 470 PF 5% 50V
C238	2113932K15	CAP CER .100 UF +80/-20% 16V
C241	2113931F17	CAP CER CHP 470 PF 5% 50V
C245 thru C247	2113932K15	CAP CER .100 UF +80/-20% 16V
C248	2113931F17	CAP CER CHP 470 PF 5% 50V
C249 thru C257	-----	NOTPLACED
C258	2113930F39	CAP CER CHP 33 PF 50V 5%
C261	2113932K15	CAP CER .100 UF +80/-20% 16V
C262 & C263	-----	NOTPLACED
C264	2113931F17	CAP CER CHP 470 PF 5% 50V

ITEM	MOTOROLA PART NUMBER	DESCRIPTION
C265 thru C267	-----	NOTPLACED
C268	2113931F17	CAP CER CHP 470 PF 5% 50V
C269 & C270	2113931F17	CAP CER CHP 470 PF 5% 50V
C271 & C272	-----	NOTPLACED
C273	2113931F17	CAP CER CHP 470 PF 5% 50V
C274 thru C279	-----	NOTPLACED
C281 & C282	2113930F39	CAP CER CHP 33 PF 50V 5%
C284 thru C287	-----	NOTPLACED
C402 thru C406	-----	NOTPLACED
C407 thru C414	2113932K15	CAP CER .100 UF +80/-20% 16V
C415	2113743A23	CAP CHIP .220 UF 10% X7R
C416 thru C422	2113932K15	CAP CER .100 UF +80/-20% 16V
C423 thru C434	-----	NOTPLACED
C435	2113932K15	CAP CER .100 UF +80/-20% 16V
C436 & C437	-----	NOTPLACED
C438	2113930F34	CAP CER CHP 20 PF 50V 5%
C439	-----	NOTPLACED
C440	2113932K15	CAP CER .100 UF +80/-20% 16V
C441	-----	NOTPLACED
C442 & C443	2113930F09	CAP 1.8 PF 50V +/-0.1 PF 50V
C444 thru C448	2113932K15	CAP CER .100 UF +80/-20% 16V
C456 thru C458	2113932K15	CAP CER .100 UF +80/-20% 16V
C459	2113930F03	CAP 1.0 PF 50V +/-0.1 PF 50V
C460	-----	NOTPLACED
C461 & C462	2113932K15	CAP CER .100 UF +80/-20% 16V
C463 thru C465	-----	NOTPLACED
C466	2113932K15	CAP CER .100 UF +80/-20% 16V
C467	2113930F24	C-P 7.5 PF 50V +/- .25 PF 50V
C468	2113743A23	CAP CHIP .220 UF 10% X7R

ITEM	MOTOROLA PART NUMBER	DESCRIPTION
C469	-----	NOTPLACED
C470	2311049C07	CAP TANT CHIP 100UF 10V 10%
C471 thru C475	-----	NOTPLACED
C476	2113932K15	CAP CER .100 UF +80/-20% 16V
C478 & C479	-----	NOTPLACED
C480	2113930F46	CAP CER CHP 62 PF 50V 5%
C481	-----	NOTPLACED
C482	2311049A05	CAP TANT CHIP A/P .47 10 25
C483	2113930F46	CAP CER CHP 62 PF 50V 5%
C484 thru C489	-----	NOTPLACED
C490	2113931F17	CAP CER CHP 470 PF 5% 50V
C491	2113931F17	CAP CER CHP 470 PF 5% 50V
CR201	-----	NOTPLACED
CR202	4884939C35	DIODE HOT CAR 39C35 4V
CR203 & CR204	-----	NOTPLACED
CR401	4884939C35	DIODE HOT CAR 39C35 4V
CR402	4813825A06	PIN DIODE 35V
CR403	-----	NOTPLACED
J201 & J401	-----	NOTPLACED
J501	0905516W02	CONN RECEPTACLE
J601 & J701	-----	NOTPLACED
J801	0913915A11	RECP SMT LOPRO 25 POS
J901	-----	NOTPLACED
JU201 & JU401	-----	NOTPLACED
JU402 thru JU404	0662057B47	CHIP RES 0 OHMS +/- .050 OHMS
JU405	-----	NOTPLACED
JU407	0662057B47	CHIP RES 0 OHMS +/- .050 OHMS
L201	2460578C43	INDUCTOR CHIP 33.0UH 10%
L203 thru L206	-----	NOTPLACED
L208 thru L223	-----	NOTPLACED
L401 & L402	-----	NOTPLACED
L403	2462587E71	CHIPINDUCTOR 1800 NH 5%

ITEM	MOTOROLA PART NUMBER	DESCRIPTION
Q201 thru Q203	-----	NOTPLACED
Q204 thru Q206	4805128M12	TSTR SOT BCW 60B (RH)
Q207	4805718V01	XSTR IC PKG
Q208	4805128M12	TSTR SOT BCW 60B (RH)
Q210	-----	NOTPLACED
Q211	4805128M40	TSTR BCW61BB LH 48G26
Q401 & Q402	-----	NOTPLACED
R201 thru R203	0662057A97	CHIP RES 100K OHMS 5%
R205	0662057A97	CHIP RES 100K OHMS 5%
R206	-----	NOTPLACED
R207	0662057A73	CHIP RES 10K OHMS 5%
R208 thru R210	-----	NOTPLACED
R212	0662057A73	CHIP RES 10K OHMS 5%
R213 thru R217	-----	NOTPLACED
R218	0662057A65	CHIP RES 4700 OHMS 5%
R219	0662057A97	CHIP RES 100K OHMS 5%
R220	-----	NOTPLACED
R221	0662057A73	CHIP RES 10K OHMS 5%
R222	0662057G08	CHIP RES 82.5 K OHMS 1%
R223	0662057R92	RES CHIP 47.5K .1W 1%
R224	0662057A85	CHIP RES 33K OHMS 5%
R225	0662057B47	CHIP RES 0 OHMS +/- .050 OHMS
R226 & R227	0662057A97	CHIP RES 100K OHMS 5%
R228	-----	NOTPLACED
R230	0662057A65	CHIP RES 4700 OHMS 5%
R231	0662057B22	CHIP RES 1.0 MEG OHMS 5%
R232	0662057A65	CHIP RES 4700 OHMS 5%
R233	0662057A85	CHIP RES 33K OHMS 5%
R234 & R235	0662057A73	CHIP RES 10K OHMS 5%
R237	0662057A73	CHIP RES 10K OHMS 5%
R238	0662057A97	CHIP RES 100K OHMS 5%
R239	0662057A65	CHIP RES 4700 OHMS 5%
R240 thru R242	-----	NOTPLACED
R243 thru R246	0662057A97	CHIP RES 100K OHMS 5%
R249	-----	NOTPLACED
R251	0662057B47	CHIP RES 0 OHMS +/- .050 OHMS
R252	0662057A97	CHIP RES 100K OHMS 5%
R253 thru R256	-----	NOTPLACED

ITEM	MOTOROLA PART NUMBER	DESCRIPTION
R259 & R260	0662057A97	CHIP RES 100K OHMS 5%
R261	0662057A73	CHIP RES 10K OHMS 5%
R262	0662057A89	CHIP RES 47K OHMS 5%
R263	0662057A73	CHIP RES 10K OHMS 5%
R263	-----	NOTPLACED
R264	0662057A82	CHIP RES 24K OHMS 5%
R265 & R266	0662057A97	CHIP RES 100K OHMS 5%
R267	0662057A73	CHIP RES 10K OHMS 5%
R268	0662057A97	CHIP RES 100K OHMS 5%
R269	0662057A85	CHIP RES 33K OHMS 5%
R272	0662057A73	CHIP RES 10K OHMS 5%
R273	0662057A97	CHIP RES 100K OHMS 5%
R274 thru R282	0662057A85	CHIP RES 33K OHMS 5%
R283	-----	NOTPLACED
R284	0662057A97	CHIP RES 100K OHMS 5%
R285 thru R287	-----	NOTPLACED
R289 thru R307	-----	NOTPLACED
R402	0662057B12	CHIP RES 390K OHMS 5%
R403	-----	NOTPLACED
R404	0662057A73	CHIP RES 10K OHMS 5%
R405	0662057B22	CHIP RES 1.0 MEG OHMS 5%
R406	-----	NOTPLACED
R407	0662057A97	CHIP RES 100K OHMS 5%
R408	-----	NOTPLACED
R409 thru R414	0662057A73	CHIP RES 10K OHMS 5%
R415	0662057A97	CHIP RES 100K OHMS 5%
R416	-----	NOTPLACED
R417	0662057A97	CHIP RES 100K OHMS 5%
R418	0662057A49	CHIP RES 1000 OHMS 5%
R419	0662057A73	CHIP RES 10K OHMS 5%
R420	0662057A97	CHIP RES 100K OHMS 5%
R421 & R423	-----	NOTPLACED
R424	0662057A63	CHIP RES 3900 OHMS 5%
R425	0662057A69	CHIP RES 6800 OHMS 5%
R426 thru R430	-----	NOTPLACED
R432	0662057A73	CHIP RES 10K OHMS 5%
R433	0662057A57	CHIP RES 2200 OHMS 5%
R434	-----	NOTPLACED
R435	0662057A73	CHIP RES 10K OHMS 5%
R436 thru R438	-----	NOTPLACED
R477 thru R480	-----	NOTPLACED

ITEM	MOTOROLA PART NUMBER	DESCRIPTION
R481	0662057A97	CHIP RES 100K OHMS 5%
R482	0662057B47	CHIP RES 0 OHMS +/- .050 OHMS
R483 thru R485	0662057A97	CHIP RES 100K OHMS 5%
R490 thru R492	-----	NOTPLACED
U201	5105625U33	IC 32KX8 EE EPROM 28 PIN TSOP
U202	5105662U54	HYBRID 32K X 8 SRAM TESTED
U204	5105662U52	HYBRID CC HC11F1
U205	5105625U73	IC 256K X8 FLS ROM NIN TSOP SD
U206	5105835U80	CC SLIC5 GLOBTOP DIE 91W30 86P
U208	-----	NOTPLACED
U210	5105625U73	IC 256K X8 FLS ROM NIN TSOP SD
U211	5105279V65	IC
U401	-----	NOTPLACED
U402 & U403	5105329V12	HYBRID CC BUMPED TEST 5596E99
U404	5105625U73	IC 256K X8 FLS ROM NIN TSOP SD
U405	5105457W70	CC OMPAC DSP56001A
U406	5105457W19	CC ADSIC ABACUS/DSP SUP/OMPAC
U407	5105492X73	IC 4.2V VOLTAGE DETECTOR
U408 thru U412	-----	NOTPLACED
U414	5105329V12	HYBRID CC BUMPED TEST 5596E99
U415	5105492X05	IC SNG HI SPD L-MOS OR GATE
VR201 thru VR203	4813830A15	DIODE 5.6V 5% 225MW MMBZ5232B_
VR204 & VR205	-----	NOTPLACED
VR206	4813830A31	DIODE 18V 5% 225MW MMBZ5248B_
VR207	4813830A22	DIODE 9.1V 5% 225MW MMBZ5239B_
VR208	4813830A24	DIODE 11V 5% 225MW MMBZ5241B_
VR209	4813830A15	DIODE 5.6V 5% 225MW MMBZ5232B_
VR210	-----	NOTPLACED
VR211 thru VR214	4813830A15	DIODE 5.6V 5% 225MW MMBZ5232B_
VR215 thru VR223	-----	NOTPLACED

ITEM	MOTOROLA PART NUMBER	DESCRIPTION
Y201	4805574W01	XTAL PRL RESONANCE 7.3728 MHZ
Y401	4805573W01	CRYSTAL SERIAL RESONANCE

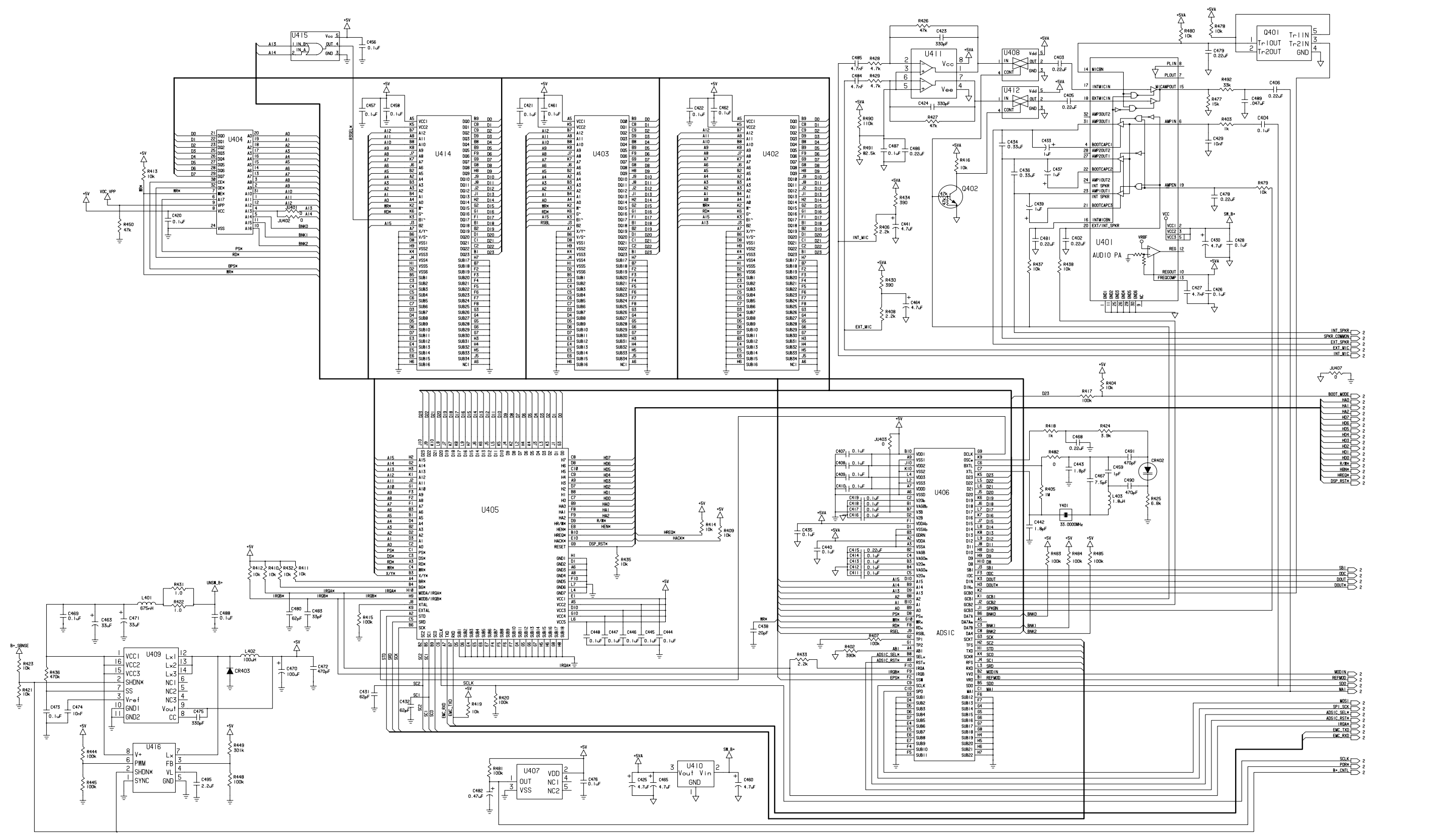

HLN6458E VOCON Board Schematic (Sheet 1 of 2)

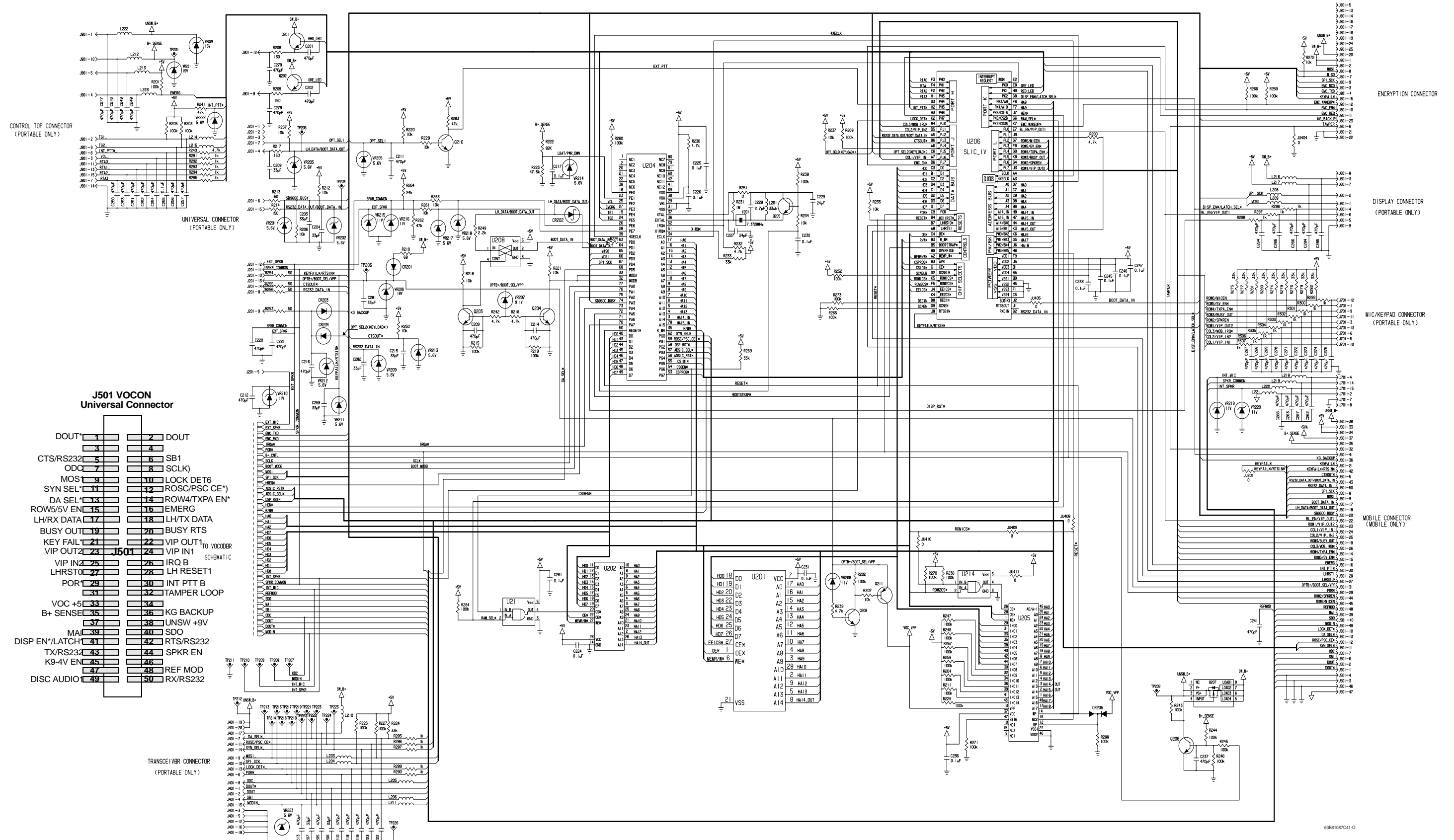

J501 VOCON Universal Connector

DOUT ⁺ 1	2	DOUT
3	4	
CTS/RS232 5	6	SB1
ODQ 7	8	SCLK
MOS 9	10	LOCK DET6
SYN SEL ⁺ 11	12	ROSC/PSC CE ⁺
DA SEL ⁺ 13	14	ROW4/TPXA EN ⁺
ROW5/5V EN 15	16	EMERG
LH/RX DATA 17	18	LH/TX DATA
BUSY OUT 19	20	BUSY RTS
KEY FAIL 21	22	VIP OUT1
VIP OUT2 23	24	VIP IN1 TO VOCCODR SCHEMATIC
VIP IN2 25	26	IRQ B
LHRSTO 27	28	LH RESET1
POR 29	30	INT PTT B
31	32	TAMPER LOOP
VOC +5 33	34	KG BACKUP
B+ SENSE 35	36	UNSW +9V
37	38	SDO
MAI 39	40	RTS/RS232
DISP EN/LATCH 41	42	SPKR EN
TX/RS232 43	44	REF MOD
K9-4V EN 45	46	RX/RS232
47	48	
49	50	

HLN6458E VOCON Board Schematic (Sheet 2 of 2)

VIEWED FROM SIDE 1

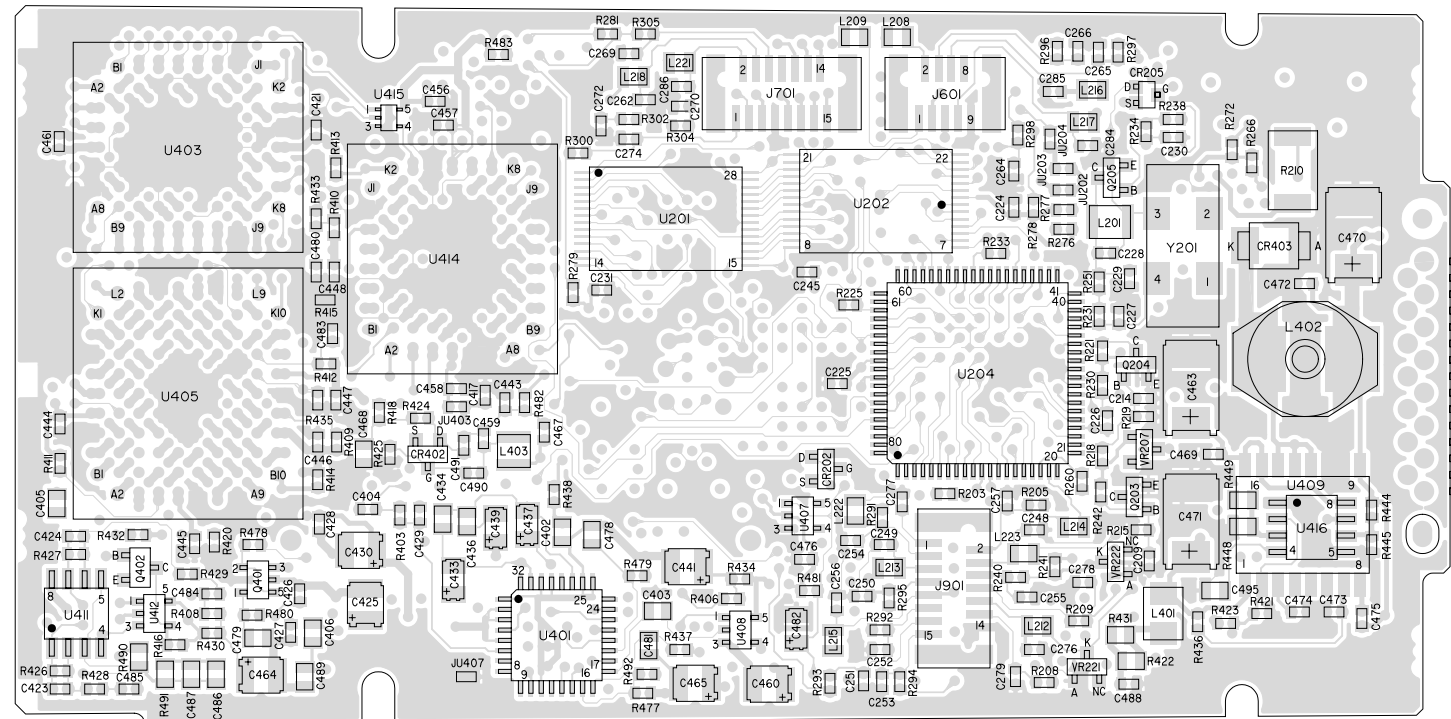

MAEPF-26123-O

VIEWED FROM SIDE 2

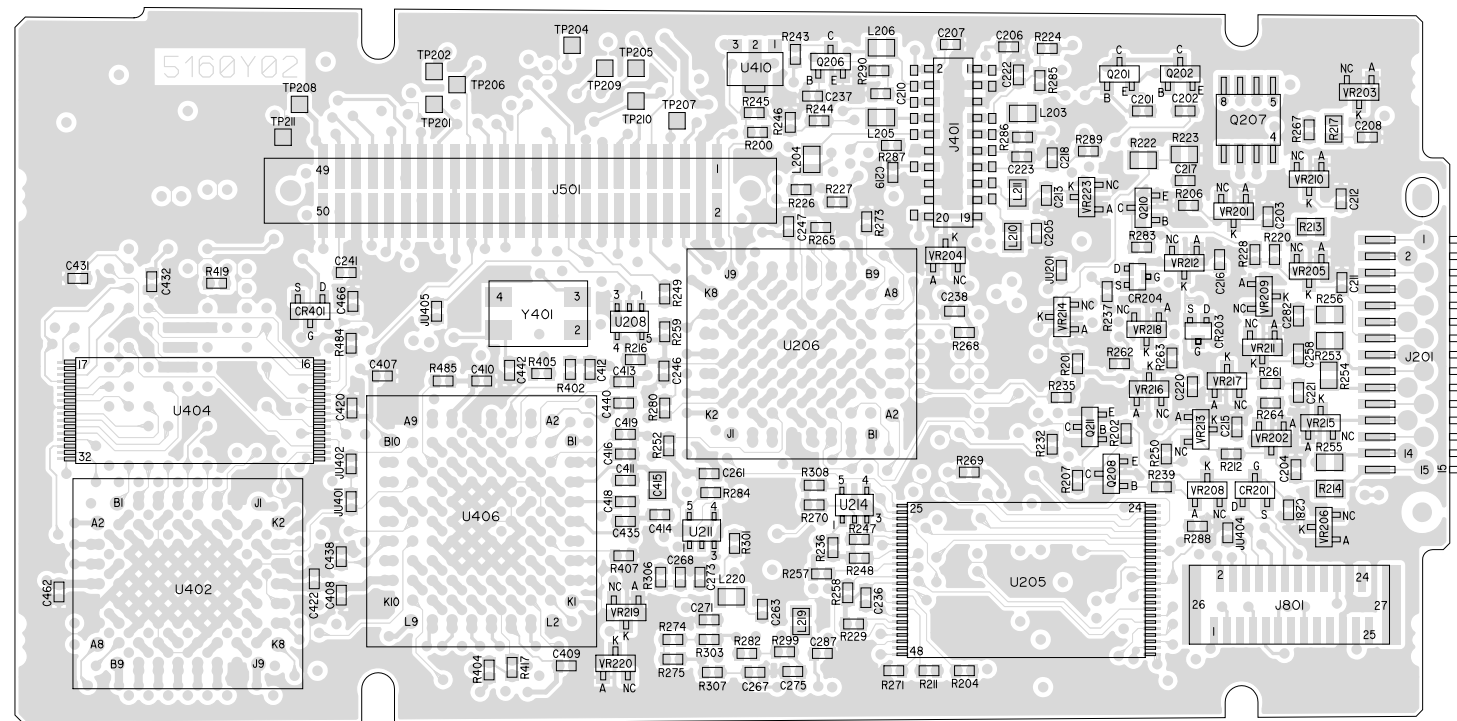

MAEPF-26124-O

HLN6458E VOCON Board Component Location Diagrams (Sheet 2 of 2)

ITEM	MOTOROLA PART NUMBER	DESCRIPTION
U211	5105279V65	AND Gate
U214	5105279V65	AND Gate
U401	-----	Not Placed
U402, 403	5105329V12	8k x 24 DSPRAM
U404	5105625U73	FLASH (TSOP)
U405	5105457W70	Digital Signal Processor
U406	5105457W19	ADSIC (ABACUS/DSP Support IC)
U407	5105492X73	Voltage Detector XSX
U408 thru 412	-----	Not Placed
U414	5105329V12	8k x 24 DSPRAM
U415	5105492X05	OR Gate
U416	-----	Not Placed
		DIODE: See Note 1.
VR201 thru 203	4813830A15	Zener, 5.6V
VR204, 205	-----	Not Placed
VR206	4813830A31	Zener, 18V
VR207	4813830A22	Zener, 9.1V
VR208	4813830A24	Zener, 11V
VR209	4813830A15	Zener, 5.6V
VR210	-----	Not Placed
VR211 thru 214	4813830A15	Zener, 5.6V
VR215 thru 223	-----	Not Placed
		CRYSTAL: See Note 2.
Y201	4805574W01	7.3728MHz
Y401	4805573W01	33MHz
		MISCELLANEOUS:
	8405160Y02	Printed Circuit Board

Notes:

- For optimum performance, order replacement diodes, transistors, and circuit modules by Motorola part number only.
- When ordering crystals, specify carrier frequency, crystal frequency, crystal type number, and Motorola part number.
- Part value notations:
 $p=10^{-12}$
 $n=10^{-9}$
 $\mu=10^{-6}$
 $m=10^{-3}$
 $k=10^3$
 $M=10^6$
- ITEM refers to the component reference designator. SIDE refers to the location of the component on the board; S1=Side 1, S2=Side 2.
- The VOCON Board Kit uses a 6-layer printed circuit board.

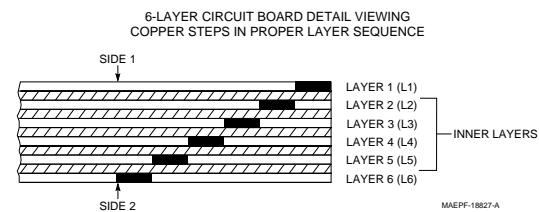

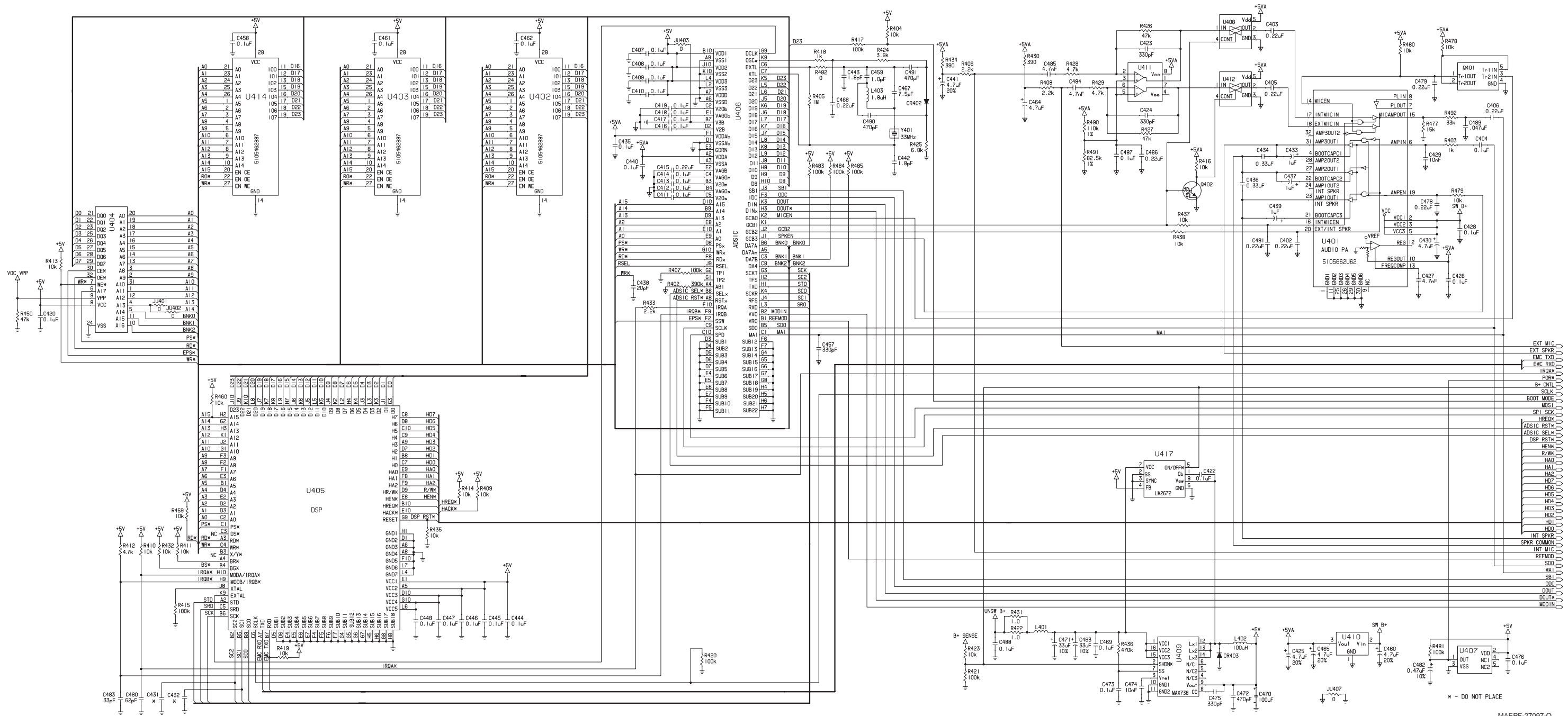

HLN6458F/G VOCON Board Schematic (Sheet 1 of 2)

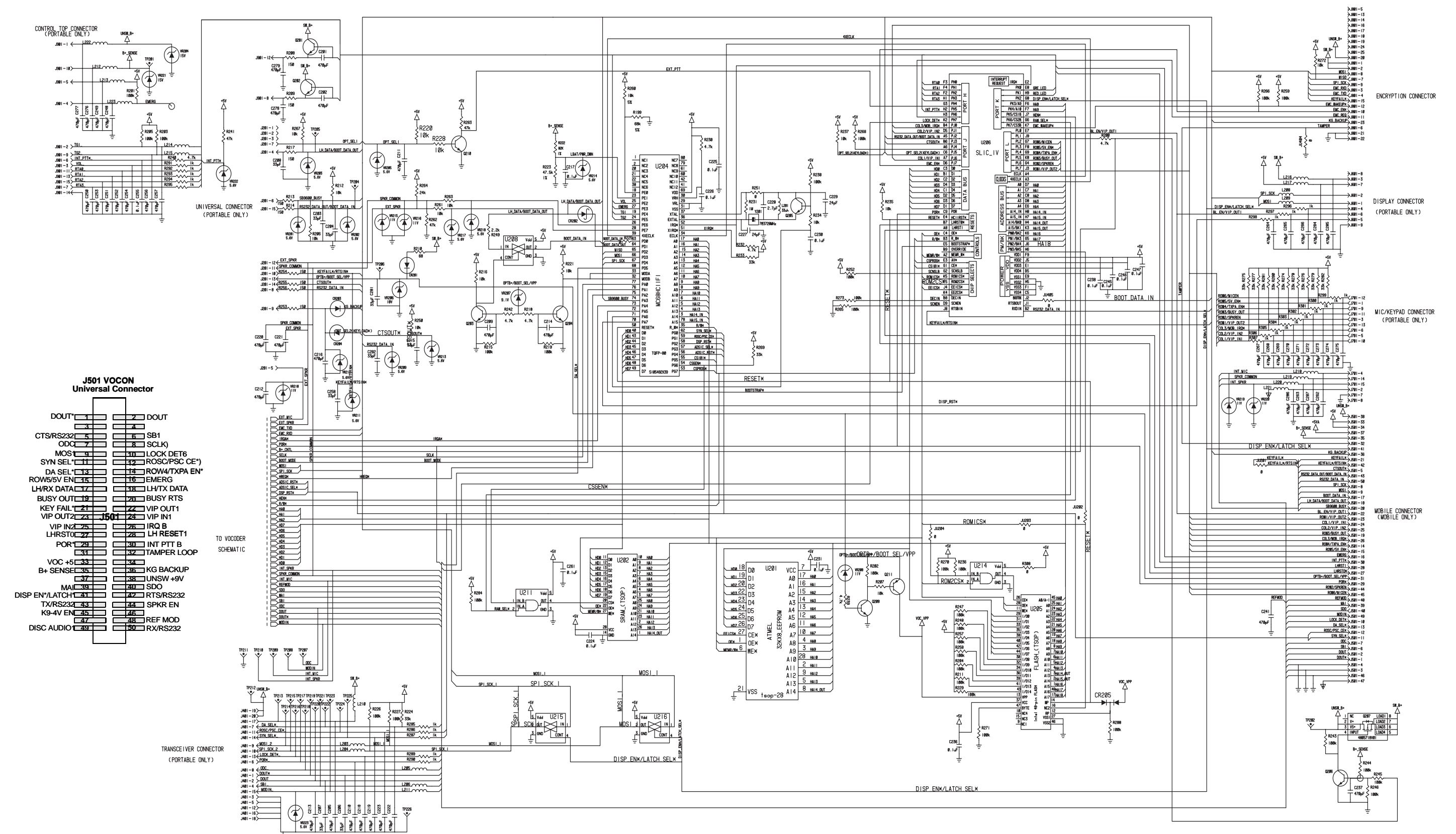

HLN6458F/G VOCON Board Schematic (Sheet 2 of 2)

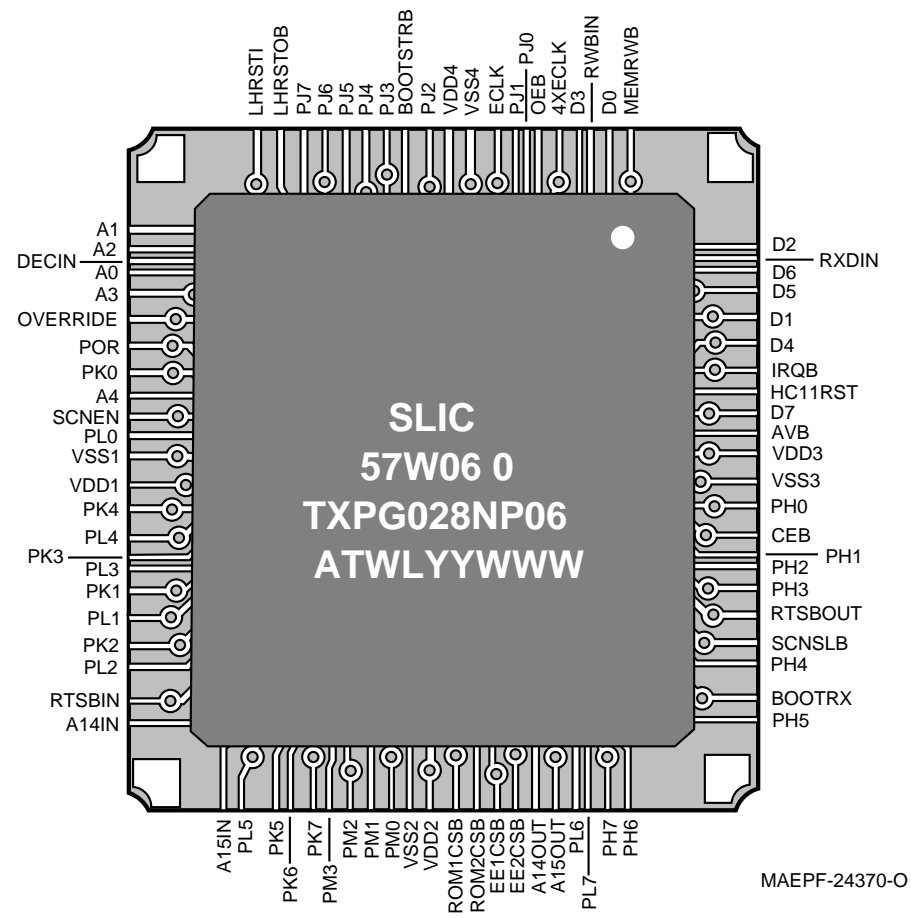

U206 - SLIC

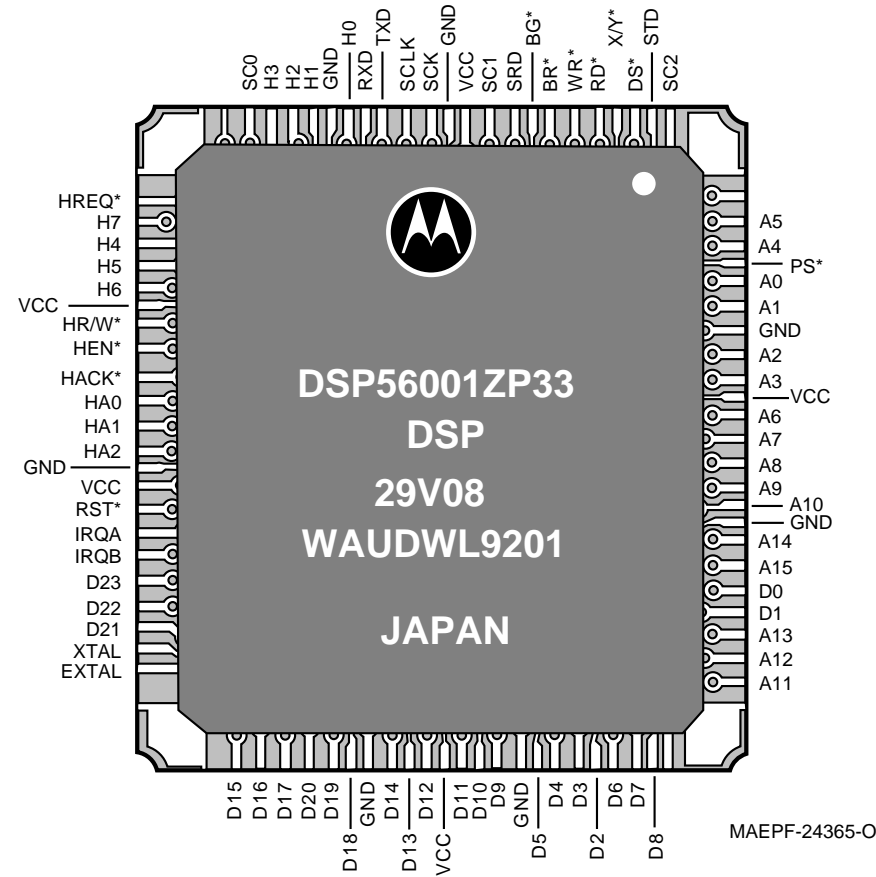

U405 - DSP

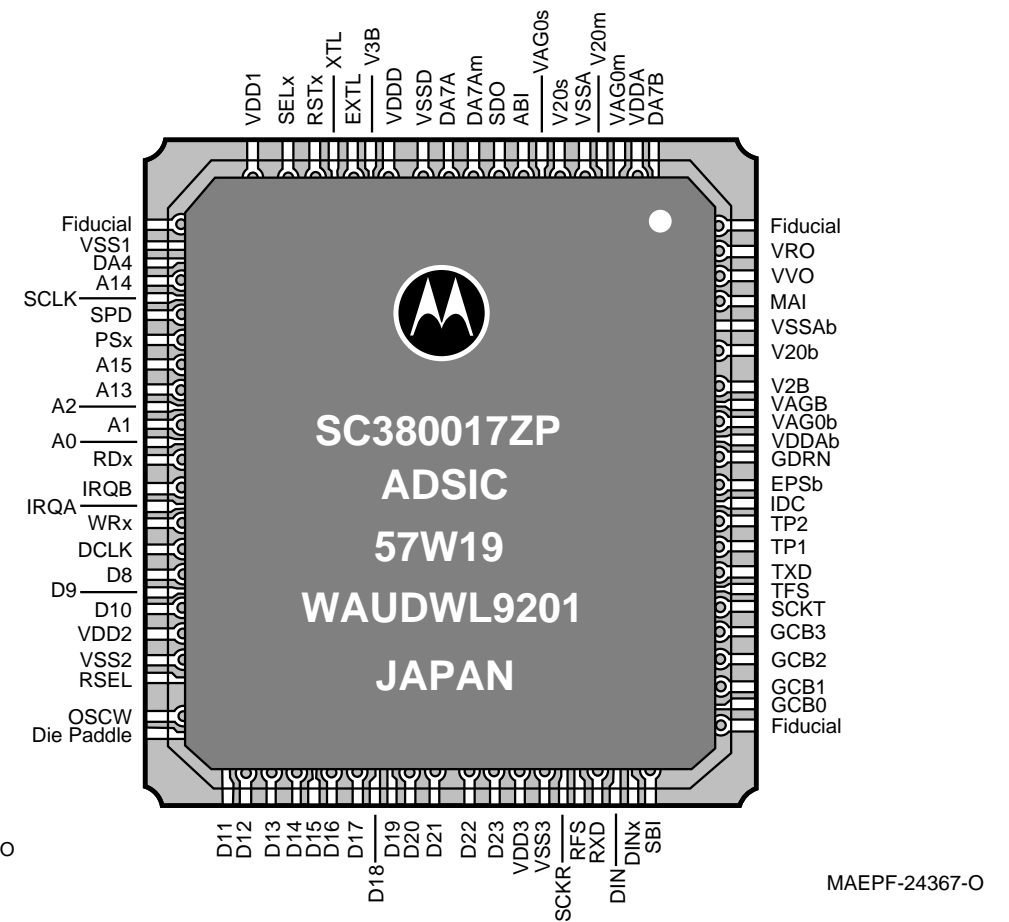

U406 - ADSIC

VIEWED FROM SIDE 1

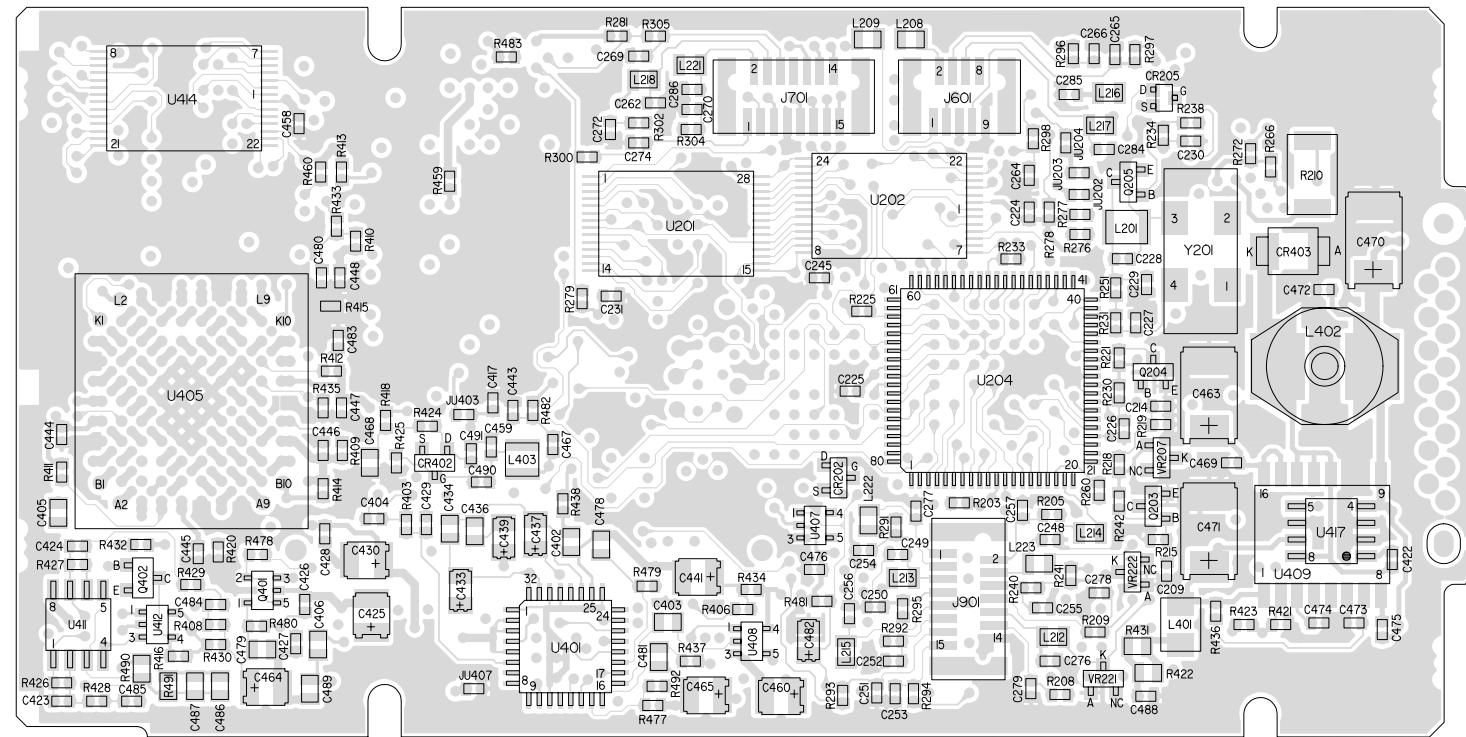

MAEPF-27095-O

VIEWED FROM SIDE 2

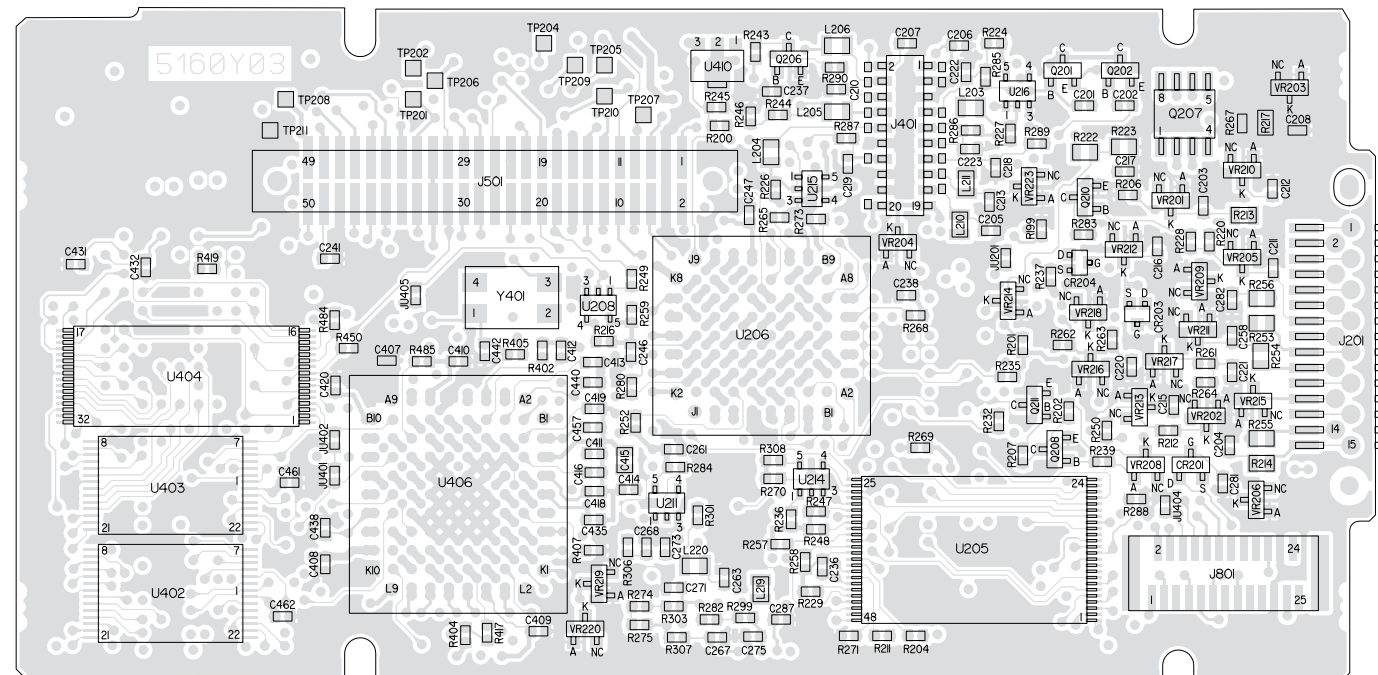

MAEPF-27096-O

HLN6458F/G VOCON Board Component Location Diagrams (Sheet 2 of 2)

HLN6458F/G VOCON Board Parts List

ITEM	MOTOROLA PART NUMBER	DESCRIPTION
C201 & C202	-----	NOTPLACED
C203 & C204	2113930F39	CAP CER CHP 33 PF 50V 5%
C205 thru C213	-----	NOTPLACED
C214	2113931F17	CAP CER CHP 470 PF 5% 50V
C215	2113930F39	CAP CER CHP 33 PF 50V 5%
C216	-----	NOTPLACED
C217	2113932K15	CAP CER .100 UF +80/-20% 16V
C218	-----	NOTPLACED
C219	2113931F17	CAP CER CHP 470 PF 5% 50V
C220 & C222	-----	NOTPLACED
C222 & C223	2113931F17	CAP CER CHP 470 PF 5% 50V
C224 thru C226	2113932K15	CAP CER .100 UF +80/-20% 16V
C227	2113930F36	CAP CER CHP 24 PF 50V 5%
C228	-----	NOTPLACED
C229	2113930F36	CAP CER CHP 24 PF 50V 5%
C230 & C231	2113932K15	CAP CER .100 UF +80/-20% 16V
C236	2113932K15	CAP CER .100 UF +80/-20% 16V
C237	2113931F17	CAP CER CHP 470 PF 5% 50V
C238	2113932K15	CAP CER .100 UF +80/-20% 16V
C241	2113931F17	CAP CER CHP 470 PF 5% 50V
C245 thru C247	2113932K15	CAP CER .100 UF +80/-20% 16V
C248	2113931F17	CAP CER CHP 470 PF 5% 50V
C249 thru C257	-----	NOTPLACED
C258	2113930F39	CAP CER CHP 33 PF 50V 5%
C261	2113932K15	CAP CER .100 UF +80/-20% 16V
C262 thru C264	-----	NOTPLACED
C264	2113931F17	CAP CER CHP 470 PF 5% 50V
C265 thru C268	-----	NOTPLACED
C268	2113931F17	CAP CER CHP 470 PF 5% 50V

ITEM	MOTOROLA PART NUMBER	DESCRIPTION
C269	-----	NOTPLACED
C269 & C270	2113931F17	CAP CER CHP 470 PF 5% 50V
C271 thru C273	-----	NOTPLACED
C273	2113931F17	CAP CER CHP 470 PF 5% 50V
C274 thru C279	-----	NOTPLACED
C281 & C282	2113930F39	CAP CER CHP 33 PF 50V 5%
C284 thru C287	-----	NOTPLACED
C402 thru C406	-----	NOTPLACED
C407 thru C414	2113932K15	CAP CER .100 UF +80/-20% 16V
C415	2113743A23	CAP CHIP .220 UF 10% X7R
C416 thru C420	2113932K15	CAP CER .100 UF +80/-20% 16V
C422 thru C434	-----	NOTPLACED
C435	2113932K15	CAP CER .100 UF +80/-20% 16V
C436 & C437	-----	NOTPLACED
C438	2113930F34	CAP CER CHP 20 PF 50V 5%
C439	-----	NOTPLACED
C440	2113932K15	CAP CER .100 UF +80/-20% 16V
C441	-----	NOTPLACED
C442 & C443	2113930F09	CAP 1.8 PF 50V +/-0.1 PF 50V
C444 thru C448	2113932K15	CAP CER .100 UF +80/-20% 16V
C457	2113931F13	CAP CER CHP 330 PF 5% 50V
C458	2113932K15	CAP CER .100 UF +80/-20% 16V
C459	2113930F03	CAP 1.0 PF 50V +/-0.1 PF 50V
C460	-----	NOTPLACED
C461 & C462	2113932K15	CAP CER .100 UF +80/-20% 16V
C463 thru C465	-----	NOTPLACED
C467	2113930F24	C~P 7.5 PF 50V +/-0.25 PF 50V
C468	2113743A23	CAP CHIP .220 UF 10% X7R
C469	-----	NOTPLACED
C470	2311049C07	CAP TANT CHIP 100UF 10V 10%

ITEM	MOTOROLA PART NUMBER	DESCRIPTION
C471 thru C475	-----	NOTPLACED
C476	2113932K15	CAP CER .100 UF +80/-20% 16V
C478 & C479	-----	NOTPLACED
C480	2113930F46	CAP CER CHP 62 PF 50V 5%
C481	-----	NOTPLACED
C482	2311049A05	CAP TANT CHIP A/P .47 10 25
C483	2113930F39	CAP CER CHP 33 PF 50V 5%
C484 thru C489	-----	NOTPLACED
C490 & C491	2113931F17	CAP CER CHP 470 PF 5% 50V
CR201	-----	NOTPLACED
CR202	4884939C35	DIODE HOT CAR 39C35 4V
CR203 & CR204	-----	NOTPLACED
CR205	4805218N57	DIODE DUAL
CR402	4813825A06	PIN DIODE 35V
CR403	-----	NOTPLACED
J201 & J401	-----	NOTPLACED
J501	0905516W02	CONN RECEPTACLE
J601 & J701	-----	NOTPLACED
J801	0913915A11	RECP SMT LOPRO 25 POS
J901	-----	NOTPLACED
JU201	-----	NOTPLACED
JU202	0662057B47	CHIP RES 0 OHMS +/-0.050 OHMS
JU203	-----	NOTPLACED
JU204	0662057B47	CHIP RES 0 OHMS +/-0.050 OHMS
JU401	-----	NOTPLACED
JU402 thru JU404	0662057B47	CHIP RES 0 OHMS +/-0.050 OHMS
JU405	-----	NOTPLACED
JU407	0662057B47	CHIP RES 0 OHMS +/-0.050 OHMS
L201	2460578C43	INDUCTOR CHIP 33.0UH 10%
L203 thru L206	-----	NOTPLACED
L208 thru L223	-----	NOTPLACED
L401 & L402	-----	NOTPLACED
L403	2462587E71	CHIPINDUCTOR 1800 NH 5%
Q201 thru Q203	-----	NOTPLACED
Q204 thru Q206	4805128M12	TSTR SOT BCW 60B (RH)
Q207	4805718V01	XSTR IC PKG

ITEM	MOTOROLA PART NUMBER	DESCRIPTION
Q208	4805128M12	TSTR SOT BCW 60B (RH)
Q210	-----	NOTPLACED
Q211	4805128M40	TSTR BCW61BB LH 48G26
Q401 & Q402	-----	NOTPLACED
R199	-----	NOTPLACED
R200	0662057A65	CHIP RES 4700 OHMS 5%
R201 thru R205	0662057A97	CHIP RES 100K OHMS 5%
R206	-----	NOTPLACED
R207	0662057A73	CHIP RES 10K OHMS 5%
R208 thru R210	-----	NOTPLACED
R211	0662057A97	CHIP RES 100K OHMS 5%
R212	0662057A73	CHIP RES 10K OHMS 5%
R213 thru R217	-----	NOTPLACED
R218	0662057A65	CHIP RES 4700 OHMS 5%
R219	0662057A97	CHIP RES 100K OHMS 5%
R220	-----	NOTPLACED
R221	0662057A73	CHIP RES 10K OHMS 5%
R222	0662057G08	CHIP RES 82.5 K OHMS 1%
R223	0662057R92	RES CHIP 47.5K .1W 1%
R224	0662057A85	CHIP RES 33K OHMS 5%
R225	0662057B47	CHIP RES 0 OHMS +/-0.050 OHMS
R226	0662057A97	CHIP RES 100K OHMS 5%
R227	0662057A97	CHIP RES 100K OHMS 5%
R228	-----	NOTPLACED
R229	0662057A97	CHIP RES 100K OHMS 5%
R230	0662057A65	CHIP RES 4700 OHMS 5%
R231	0662057B22	CHIP RES 1.0 MEG OHMS 5%
R232	0662057A65	CHIP RES 4700 OHMS 5%
R233	0662057A85	CHIP RES 33K OHMS 5%
R234 & R235	0662057A73	CHIP RES 10K OHMS 5%
R236	0662057A97	CHIP RES 100K OHMS 5%
R237	0662057A73	CHIP RES 10K OHMS 5%
R238	0662057A97	CHIP RES 100K OHMS 5%
R239	0662057A65	CHIP RES 4700 OHMS 5%
R240 thru R242	-----	NOTPLACED
R243 thru R248	0662057A97	CHIP RES 100K OHMS 5%
R249	-----	NOTPLACED
R250	0662057A73	CHIP RES 10K OHMS 5%
R251	0662057B47	CHIP RES 0 OHMS +/-0.050 OHMS
R252	0662057A97	CHIP RES 100K OHMS 5%
R253 thru R256	-----	NOTPLACED

ITEM	MOTOROLA PART NUMBER	DESCRIPTION
R257 thru R260	0662057A97	CHIP RES 100K OHMS 5%
R261	0662057A73	CHIP RES 10K OHMS 5%
R262	0662057A89	CHIP RES 47K OHMS 5%
R263	0662057A73 -----	CHIP RES 10K OHMS 5% ¹ NOTPLACED ²
R264	0662057A82	CHIP RES 24K OHMS 5%
R265 & R266	0662057A97	CHIP RES 100K OHMS 5%
R267	0662057A73	CHIP RES 10K OHMS 5%
R268	0662057A97	CHIP RES 100K OHMS 5%
R269	0662057A85	CHIP RES 33K OHMS 5%
R270	0662057A97	CHIP RES 100K OHMS 5%
R271	0662057A97	CHIP RES 100K OHMS 5%
R272	0662057A73	CHIP RES 10K OHMS 5%
R273	0662057A97	CHIP RES 100K OHMS 5%
R274	0662057A85 -----	CHIP RES 33K OHMS 5% ¹ NOTPLACED ²
R275	0662057A85	CHIP RES 33K OHMS 5%
R276	0662057A85	CHIP RES 33K OHMS 5%
R277	0662057A85	CHIP RES 33K OHMS 5%
R278	0662057A85	CHIP RES 33K OHMS 5%
R279	0662057A85	CHIP RES 33K OHMS 5%
R280	0662057A85	CHIP RES 33K OHMS 5%
R281	0662057A85	CHIP RES 33K OHMS 5%
R282	0662057A85	CHIP RES 33K OHMS 5%
R283	NOTPLACED	64AM DUMMY PART NUMBER
R284	0662057A97	CHIP RES 100K OHMS 5%
R285	NOTPLACED	64AM DUMMY PART NUMBER
R286	NOTPLACED	64AM DUMMY PART NUMBER
R287	NOTPLACED	64AM DUMMY PART NUMBER
R288	0662057A97	CHIP RES 100K OHMS 5%
R289	NOTPLACED	64AM DUMMY PART NUMBER
R290	NOTPLACED	64AM DUMMY PART NUMBER
R291	NOTPLACED	64AM DUMMY PART NUMBER
R292	NOTPLACED	64AM DUMMY PART NUMBER
R293	NOTPLACED	64AM DUMMY PART NUMBER
R294	NOTPLACED	64AM DUMMY PART NUMBER
R295	NOTPLACED	64AM DUMMY PART NUMBER
R296 thru R307	-----	NOTPLACED

ITEM	MOTOROLA PART NUMBER	DESCRIPTION
R308	0662057B47	CHIP RES 0 OHMS +/- .050 OHMS
R402	0662057B12	CHIP RES 390K OHMS 5%
R403	-----	NOTPLACED
R404	0662057A73	CHIP RES 10K OHMS 5%
R405	0662057B22	CHIP RES 1.0 MEG OHMS 5%
R406	-----	NOTPLACED
R407	0662057A97	CHIP RES 100K OHMS 5%
R408	-----	NOTPLACED
R409 thru R411	0662057A73	CHIP RES 10K OHMS 5%
R412	0662057A65	CHIP RES 4700 OHMS 5%
R413 & R414	0662057A73	CHIP RES 10K OHMS 5%
R415	0662057A97	CHIP RES 100K OHMS 5%
R416	-----	NOTPLACED
R417	0662057A97	CHIP RES 100K OHMS 5%
R418	0662057A49	CHIP RES 1000 OHMS 5%
R419	0662057A73	CHIP RES 10K OHMS 5%
R420	0662057A97	CHIP RES 100K OHMS 5%
R421 thru R423	-----	NOTPLACED
R424	0662057A63	CHIP RES 3900 OHMS 5%
R425	0662057A69	CHIP RES 6800 OHMS 5%
R426 thru R431	-----	NOTPLACED
R432	0662057A73	CHIP RES 10K OHMS 5%
R433	0662057A57	CHIP RES 2200 OHMS 5%
R434	-----	NOTPLACED
R435	0662057A73	CHIP RES 10K OHMS 5%
R436 thru R438	-----	NOTPLACED
R450	0662057A89	CHIP RES 47K OHMS 5%
R459 & R460	0662057A73	CHIP RES 10K OHMS 5%
R477 thru R480	-----	NOTPLACED
R481	0662057A97	CHIP RES 100K OHMS 5%
R482	0662057B47	CHIP RES 0 OHMS +/- .050 OHMS
R483 thru R485	0662057A97	CHIP RES 100K OHMS 5%
R490 thru R492	-----	NOTPLACED
U201	5105109Z72	IC 32X8 EEPROM 28 PIN TSOP
U202	5185963A21 5185748L01	IC, 32K X 8 SRAM ¹ 32K X 8 SRAM 28 PIN TSOP ²
U204	5113802A75	HC11F1 MICROPROCESSOR (TAPE/REEL)

ITEM	MOTOROLA PART NUMBER	DESCRIPTION
U205	5185963A84	IC 512K X 16/1M X 8 SMART VLTG
U206	5105835U80	CC SLIC5 GLOBTOP DIE 91W30 86P
U208	-----	NOTPLACED
U211 & U214	5105279V65	IC
U215 & U216	-----	NOTPLACED
U401	-----	NOTPLACED
U402	5105462G87 5185963A18	IC 32K X 8 LW PWR SRAM TSOP ¹ IC 32K X 8 LW PWR SRAM TSOP ²
U403	5105462G87 5185963A18	IC 32K X 8 LW PWR SRAM TSOP ¹ IC 32K X 8 LW PWR SRAM TSOP ²
U404	5105625U73	IC 256K X8 FLS ROM NIN TSOP SD
U405	5105457W70	CC OMPAC DSP56001A
U406	5105457W19	CC ADSIC ABACUS/DSP SUP/OMPAC
U407	5105492X73	IC 4.2V VOLTAGE DETECTOR
U408 thru U412	-----	NOTPLACED
U414	5105462G87 518963A18	IC 32K X 8 LW PWR SRAM TSOP ¹ IC 32K X 8 LW PWR SRAM TSOP ²
U417	-----	NOTPLACED
VR201 thru VR203	4813830A15	DIODE 5.6V 5% 225MW MMBZ5232B_
VR204 & VR205	-----	NOTPLACED
VR206	4813830A31	DIODE 18V 5% 225MW MMBZ5248B_
VR207	4813830A22	DIODE 9.1V 5% 225MW MMBZ5239B_
VR208	4813830A24	DIODE 11V 5% 225MW MMBZ5241B_
VR209	4813830A15	DIODE 5.6V 5% 225MW MMBZ5232B_
VR210	-----	NOTPLACED
VR211	4813830A15	DIODE 5.6V 5% 225MW MMBZ5232B_
VR212 thru VR214	4813830A15	DIODE 5.6V 5% 225MW MMBZ5232B_
VR215 thru VR223	-----	NOTPLACED
Y201	4805574W01	XTAL PRL RESONANCE 7.3728 MHZ

ITEM	MOTOROLA PART NUMBER	DESCRIPTION
Y401	4805573W01	CRYSTAL SERIAL RESONANCE
	8405160Y03	BD CKT VOCON CTRL

Notes:

1. Valid in HLN6458F only.
2. Valid in HLN6458G only.

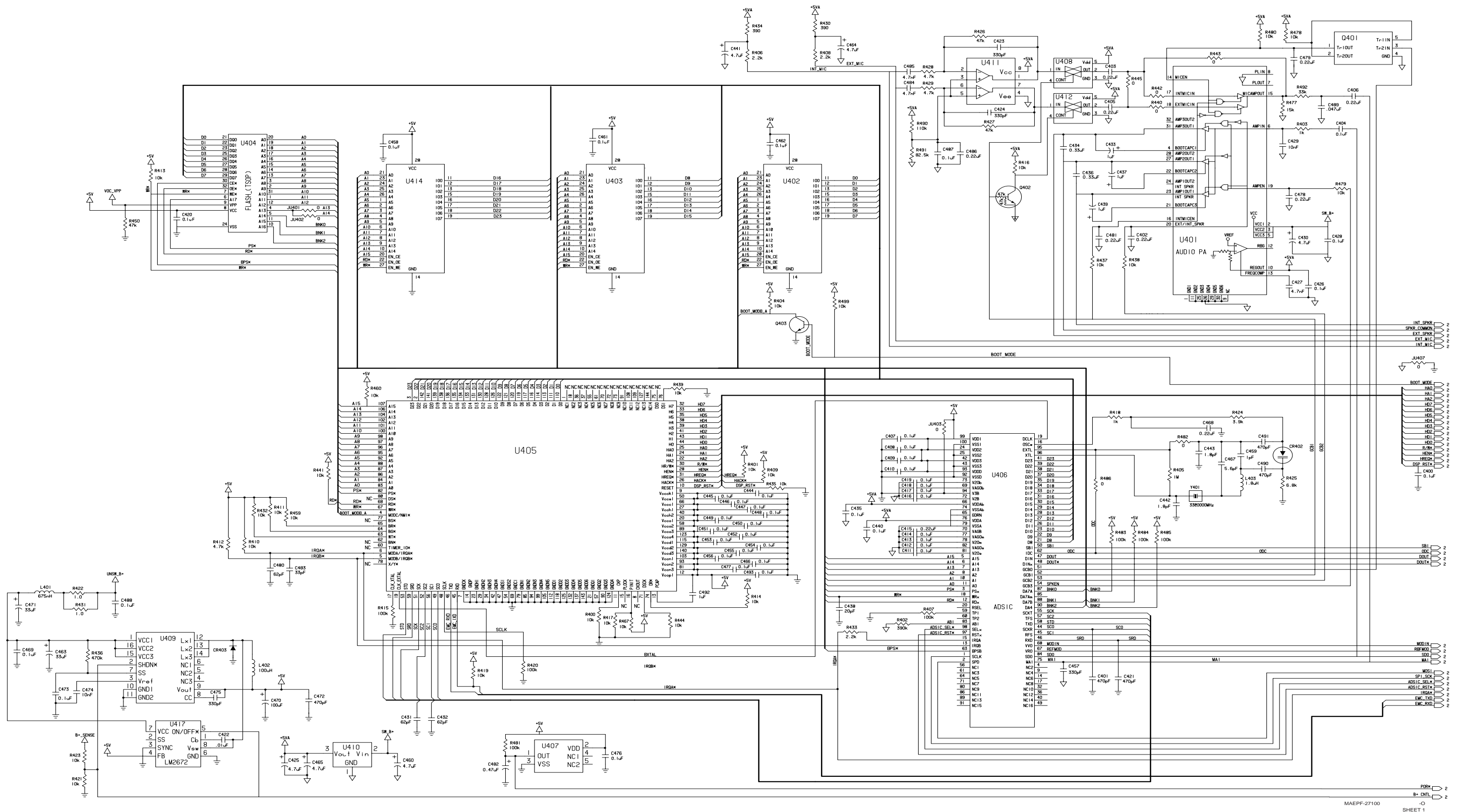

HLN6458H VOCON Board Schematic (Sheet 1 of 2)

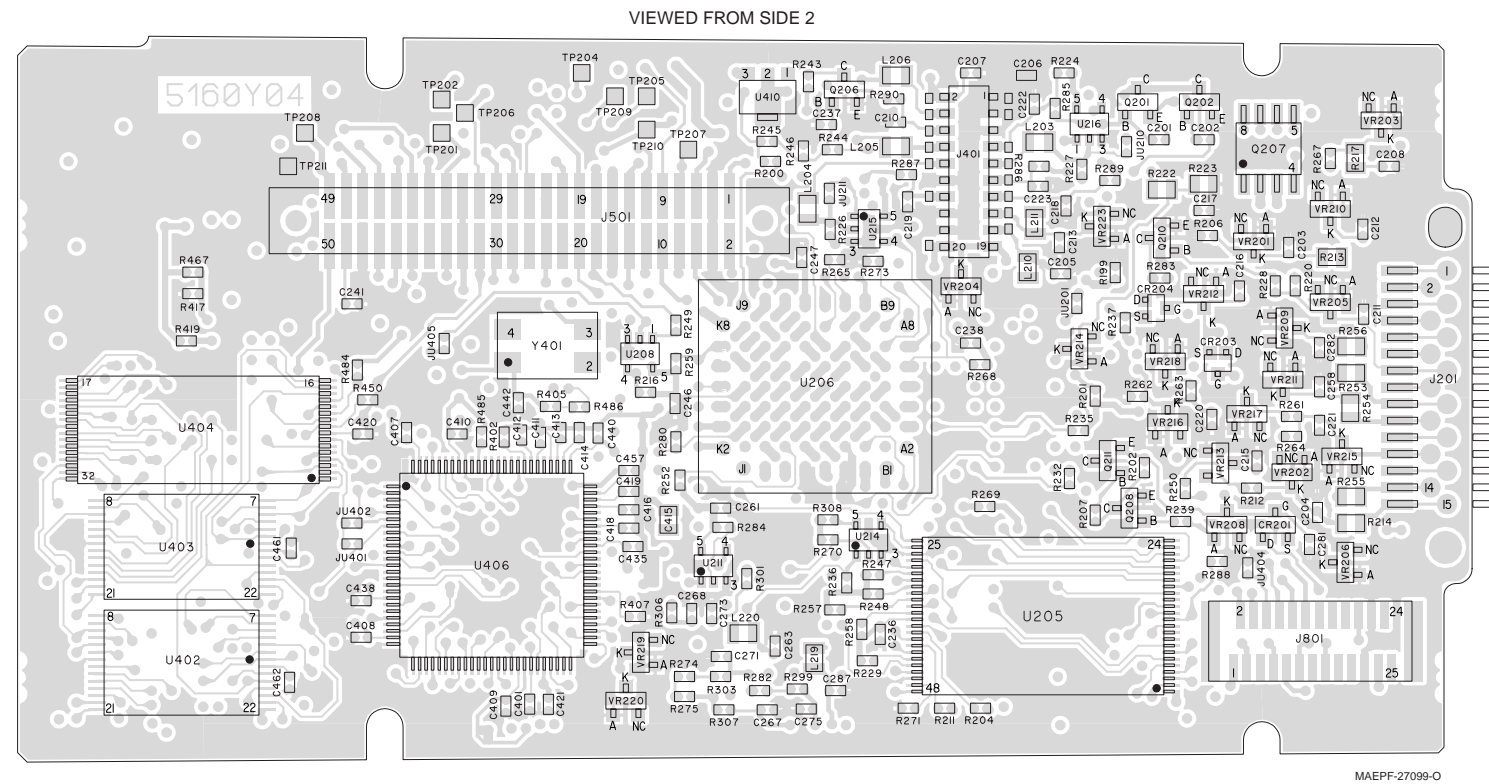
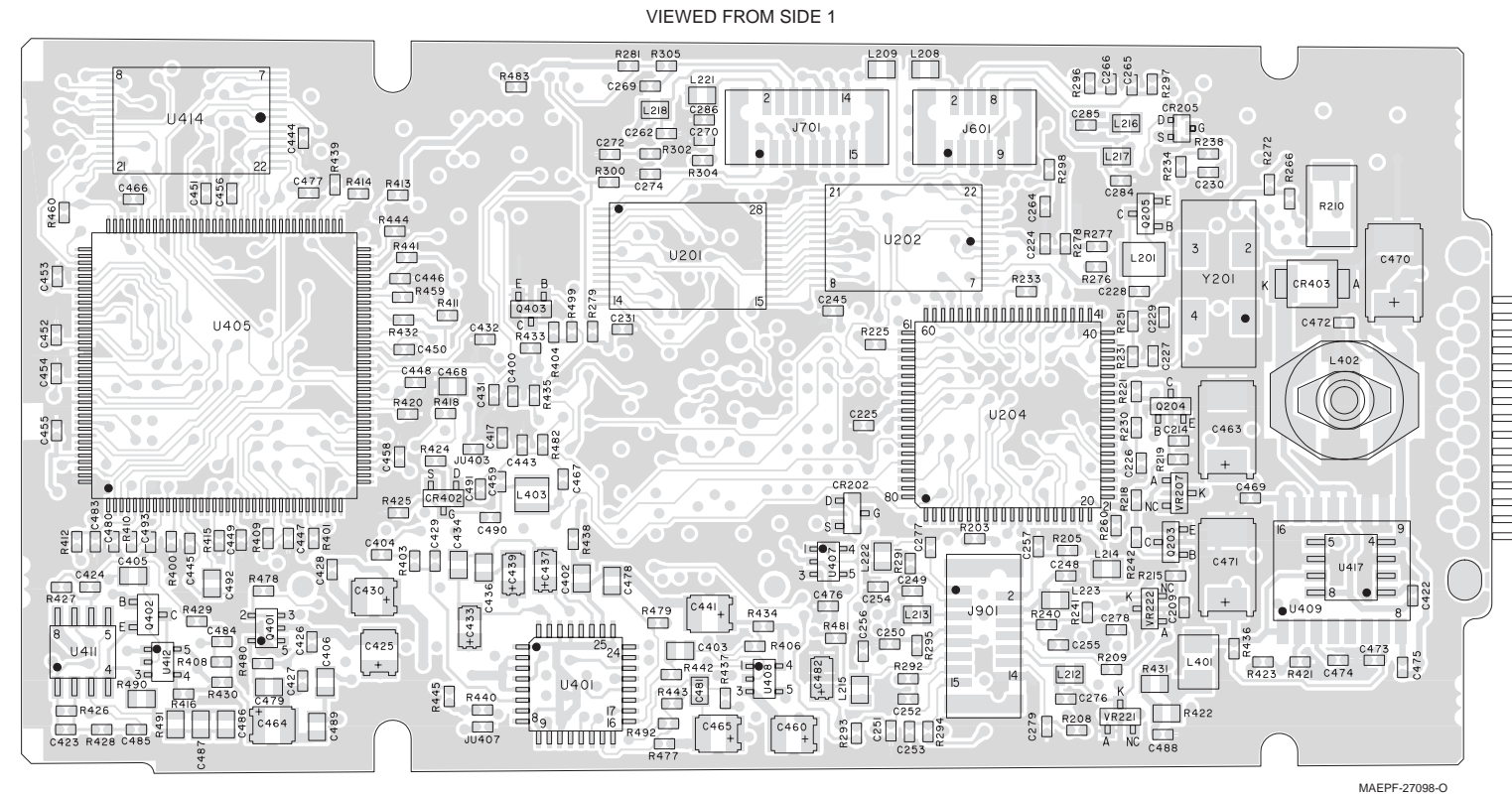
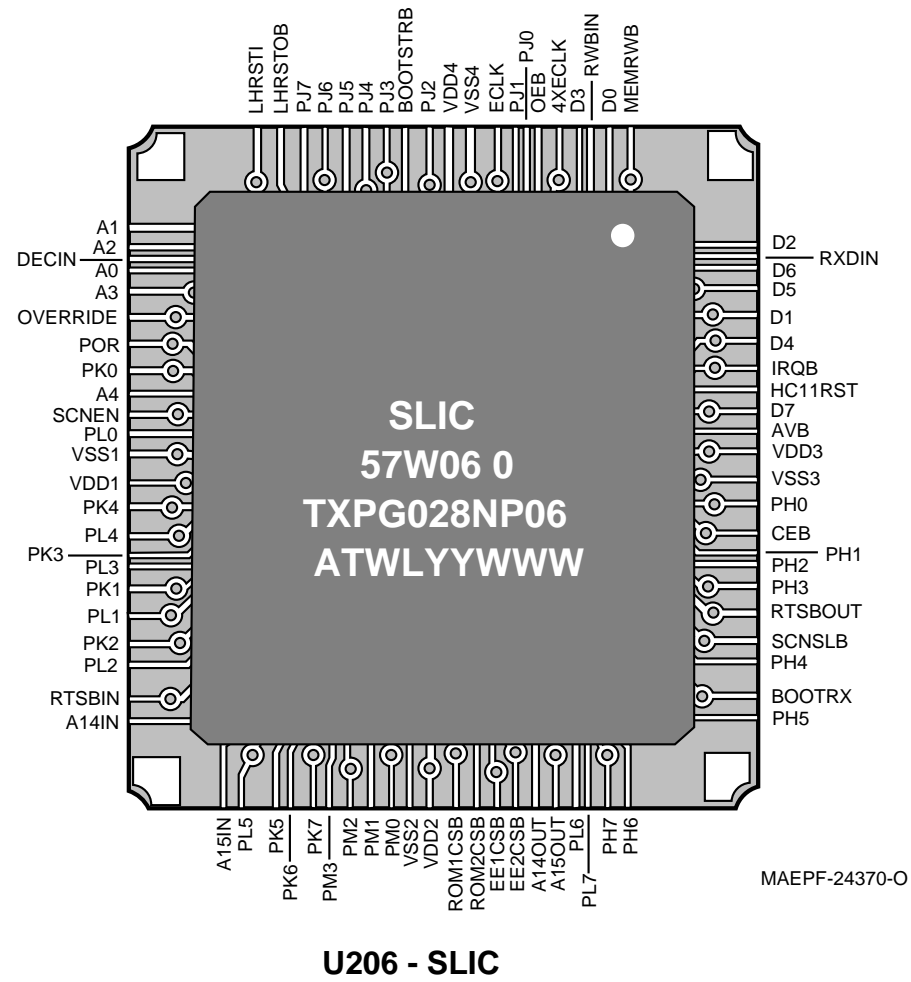

HLN6458H VOCON Board Component Location Diagrams

HLN6458H VOCON Board Electrical Parts List

ITEM	MOTOROLA PART NUMBER	DESCRIPTION
		CAPACITOR, Fixed: unless otherwise stated
C201, 202	-----	Not Placed
C203, 204	2113930F39	33pF
C205 thru 213	-----	Not Placed
C214	2113931F17	470pF
C215	2113930F39	33pF
C216	-----	Not Placed
C217	2113932K15	0.1µF
C218	-----	Not Placed
C219	2113931F17	470pF
C220, 221	-----	Not Placed
C222, 223	2113931F17	470pF
C224 thru 226	2113932K15	0.1µF
C227	2113930F36	24pF
C228	-----	Not Placed
C229	2113930F36	24pF
C230, 231	2113932K15	0.1µF
C236	2113932K15	0.1µF
C237	2113931F17	470pF
C238	2113932K15	0.1µF
C241	2113931F17	470pF
C245 thru 247	2113932K15	0.1µF
C248	2113931F17	470pF
C249 thru 257	-----	Not Placed
C258	2113930F39	33pF
C261	2113932K15	0.1µF
C262 thru 269	-----	Not Placed
C270	2113931F17	470pF
C271 thru 279	-----	Not Placed
C281, 282	2113930F39	33pF
C284 thru 287	-----	Not Placed
C400	2113932K15	0.1µF
C401	2113931F17	470pF
C402 thru 406	-----	Not Placed
C407 thru 414	2113932K15	0.1µF
C415	2113743A23	0.22µF

ITEM	MOTOROLA PART NUMBER	DESCRIPTION
C416 thru 420	2113932K15	0.1µF
C421	2113931F17	470pF
C422 thru 434	-----	Not Placed
C435	2113932K15	0.1µF
C436, 437	-----	Not Placed
C438	2113930F34	20pF
C439	-----	Not Placed
C440	2113732K15	0.1µF
C441	-----	Not Placed
C442, 443	2113930F09	1.8pF
C444 thru 456	2113932K15	0.1µF
C457	2113931F13	330pF
C458	2113932K15	0.1µF
C459	2113930F03	1pF
C460	-----	Not Placed
C461, 462	2113932K15	0.1µF
C463 thru 465	-----	Not Placed
C466	2113932K15	0.1µF
C467	2113930F21	5.6pF
C468	2113743A23	0.22µF
C469	-----	Not Placed
C470	2311049C07	100µF
C471 thru 475	-----	Not Placed
C476, 477	2113932K15	0.1µF
C478, 479	-----	Not Placed
C480	2113930F46	62pF
C481	-----	Not Placed
C482	2311049A05	0.47µF
C483	2113930F39	33pF
C484 thru 489	-----	Not Placed
C490, 491	2113931F17	470pF
C492	-----	Not Placed
C493	2113932K15	0.1µF
		DIODE: See Note 1.
CR201	-----	Not Placed
CR202	4884939C35	Hot Carrier, 4V
CR203, 204	-----	Not Placed

ITEM	MOTOROLA PART NUMBER	DESCRIPTION
CR205	4805212N57	Dual Diode
CR402	4813825A06	PIN, 35V
CR403	-----	Not Placed
		JACK:
J201	-----	Not Placed
J401	-----	Not Placed
J501	0905516W02	Connector, Receptacle
J601	-----	Not Placed
J701	-----	Not Placed
J801	0913915A11	Connector, 25-Position
J901	-----	Not Placed
		JUMPER:
JU201	-----	Not Placed
JU210, 211	-----	Not Placed
JU401	-----	Not Placed
JU402 thru 404	0662057B47	0 Ohm
JU405	-----	Not Placed
JU407	0662057B47	0 Ohm
		COIL, RF: unless otherwise stated
L201	2460578C43	33µH
L203 thru 206	-----	Not Placed
L208 thru 223	-----	Not Placed
L401, 402	-----	Not Placed
L403	2462587E71	1.8µH
		TRANSISTOR: See Note 1.
Q201 thru 203	-----	Not Placed
Q204 thru 206	4805128M12	NPN
Q207	4805718V01	PNP
Q208	4805128M12	NPN
Q210	-----	Not Placed
Q211	4805128M40	PNP
Q401, 402	-----	Not Placed
Q403	4805128M12	NPN

ITEM	MOTOROLA PART NUMBER	DESCRIPTION
		RESISTOR: W±5%; 1/8W unless otherwise stated
R199	-----	Not Placed
R200	0662057A65	4.7k
R201, 202	0662057A97	100k
R203	-----	Not Placed
R204	0662057A97	100k
R205, 206	-----	Not Placed
R207	0662057A73	10k
R208 thru 210	-----	Not Placed
R211	0662057A97	100k
R212	0662057A73	10k
R213 thru 217	-----	Not Placed
R218	0662057A65	4.7k
R219	0662057A97	100k
R220	-----	Not Placed
R221	0662057A73	10k
R222	0662057G08	82.5k
R223	0662057R92	47.5k
R224	0662057A85	33k
R225	0662057B47	0
R226, 227	0662057A97	100k
R228	-----	Not Placed
R229	0662057A97	100k
R230	0662057A65	4.7k
R231	0662057B22	1M
R232	0662057A65	4.7k
R233	0662057A85	33k
R234, 235	0662057A73	10k
R236	0662057A97	100k
R237	0662057A73	10k
R238	0662057A97	100k
R239	0662057A65	4.7k
R240 thru 242	-----	Not Placed
R243 thru 248	0662057A97	100k
R249	-----	Not Placed
R250	0662057A73	10k

ITEM	MOTOROLA PART NUMBER	DESCRIPTION
R251	0662057B47	0
R252	0662057A97	100k
R253 thru 256	-----	Not Placed
R257 thru 260	0662057A97	100k
R261	0662057A73	10k
R262	0662057A89	47k
R263	-----	Not Placed
R264	0662057A82	24k
R265, 266	0662057A97	100k
R267	0662057A73	10k
R268	0662057A97	100k
R269	0662057A85	33k
R270, 271	0662057A97	100k
R272	0662057A73	10k
R273	0662057A97	100k
R274	-----	Not Placed
R275 thru 282	0662057A85	33k
R283	-----	Not Placed
R284	0662057A97	100k
R285 thru 287	-----	Not Placed
R288	0662057A97	100k
R289 thru 307	-----	Not Placed
R308	0662057B47	0
R400, 401	0662057A73	10k
R402	0662057B12	390k
R403	-----	Not Placed
R404	0662057A73	10k
R405	0662057B22	1M
R406	-----	Not Placed
R407	0662057A97	100k
R408	-----	Not Placed
R409 thru 411	0662057A73	10k
R412	0662057A65	4.7k
R413, 414	0662057A73	10k
R415	0662057A97	100k
R416	-----	Not Placed
R417	0662057A97	100k
R418	0662057A49	1k

ITEM	MOTOROLA PART NUMBER	DESCRIPTION
R419	0662057A73	10k
R420	0662057A97	100k
R421 thru 423	-----	Not Placed
R424	0662057A63	3.9k
R425	0662057A69	6.8k
R426 thru 431	-----	Not Placed
R432	0662057A73	10k
R433	0662057A57	2.2k
R434	-----	Not Placed
R435	0662057A73	10k
R436 thru 438	-----	Not Placed
R436 thru 438	-----	Not Placed
R439	0662057A73	10k
R440	-----	Not Placed
R441	0662057A73	10k
R442, 443	-----	Not Placed
R444	0662057A73	10k
R445	-----	Not Placed
R450	0662057A89	47k
R459, 460	0662057A73	10k
R467	-----	Not Placed
R477 thru 480	-----	Not Placed
R481	0662057A97	100k
R482	0662057B47	0
R483 thru 485	0662057A97	100k
R486	-----	Not Placed
R490 thru 492	-----	Not Placed
R499	0662057A73	10k
		INTEGRATED CIRCUIT MODULE: See Note 1.
U201	5105109Z72	32k x 8 EEPROM
U202	5185748L01	SRAM (Static RAM), 32k x 8
U204	5113802A75	Microprocessor
U205	5185963A84	FLASH
U206	5185765B19	SLIC (Support-Logic IC)
U208	-----	Not Placed
U211	5105279V65	AND Gate

ITEM	MOTOROLA PART NUMBER	DESCRIPTION
U214	5105279V65	AND Gate
U215, 216	5105750U28	Switch, Bilateral CMOS
U401	-----	Not Placed
U402, 403	5185963A18	8k x 24 DSPRAM
U404	5105130C54	FLASH ROM, 256k x 8
U405	5105457W66	DSP (Digital Signal Processor)
U406	5185963A10	ADSIC (ABACUS/DSP Support IC)
U407	5105492X73	Voltage DetectorXSX
U408 thru 412	-----	Not Placed
U414	5185963A18	8k x 24 DSPRAM
U417	-----	Not Placed
		DIODE: See Note 1.
VR201 thru 203	4813830A15	Zener, 5.6V
VR204, 205	-----	Not Placed
VR206	4813830A31	Zener, 18V
VR207	4813830A22	Zener, 9.1V
VR208	4813830A24	Zener, 11V
VR209	4813830A15	Zener, 5.6V
VR210	-----	Not Placed
VR211 thru 214	4813830A15	Zener, 5.6V
VR215 thru 223	-----	Not Placed
		CRYSTAL: See Note 2.
Y201	4805574W01	7.3728MHz
Y401	4805573W01	33MHz
		MISCELLANEOUS:
	8405160Y04	Printed Circuit Board

Notes:

- For optimum performance, order replacement diodes, transistors, and circuit modules by Motorola part number only.
- When ordering crystals, specify carrier frequency, crystal frequency, crystal type number, and Motorola part number.
- Part value notations:
 $p=10^{-12}$
 $n=10^{-9}$
 $\mu=10^{-6}$
 $m=10^{-3}$
 $k=10^3$
 $M=10^6$
- ITEM refers to the component reference designator. SIDE refers to the location of the component on the board; S1=Side 1, S2=Side 2.
- The VOCON Board Kit uses a 6-layer printed circuit board.

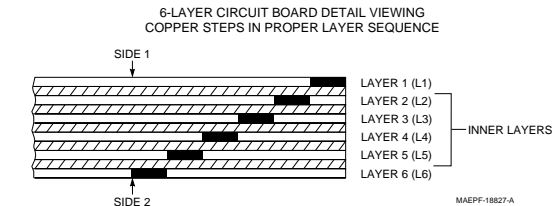

7.5 ASTRO Spectra Plus VOCON Section

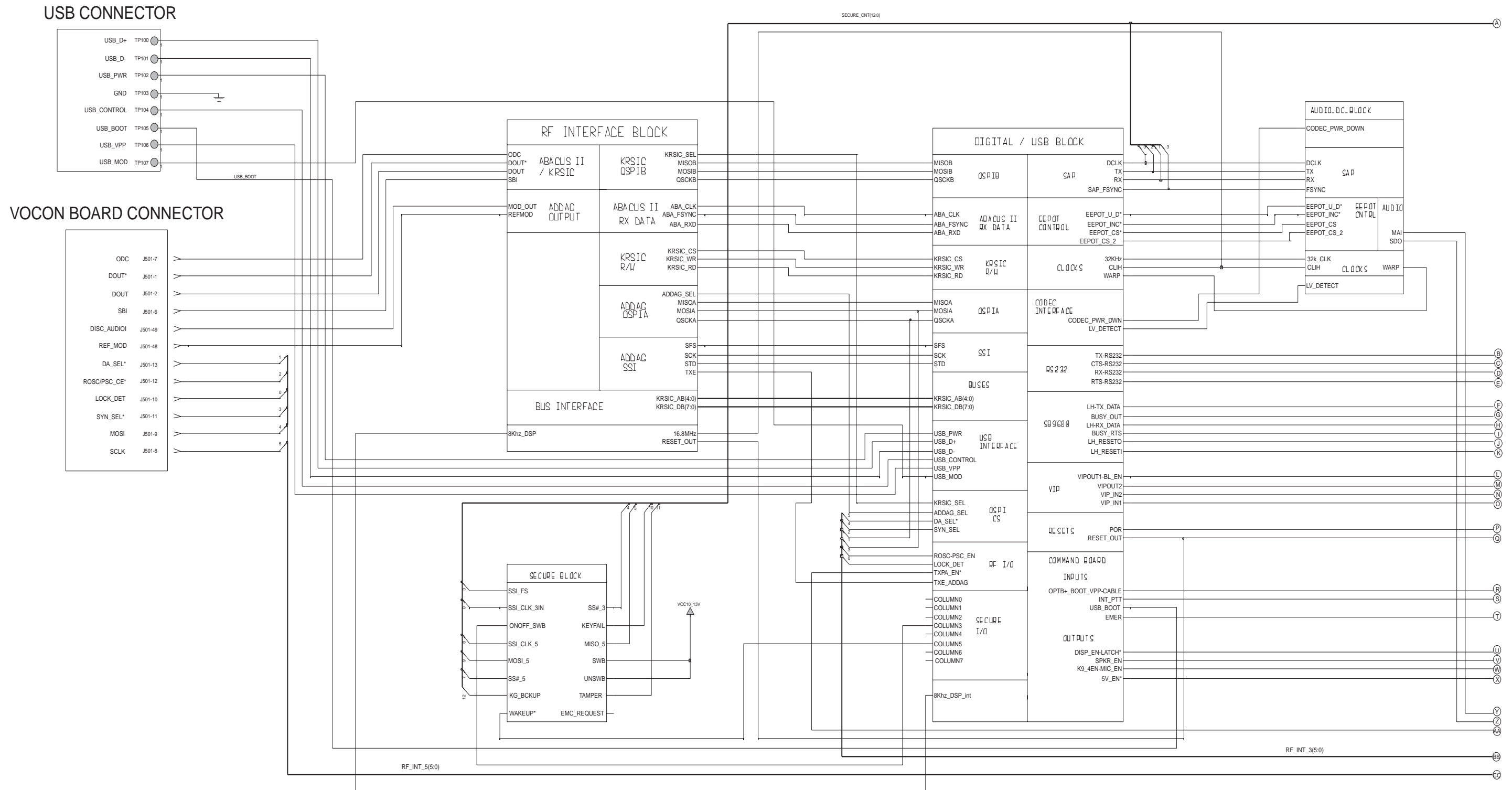

ASTRO Spectra Plus VOCON Top Level Schematic (Sheet 1 of 2)

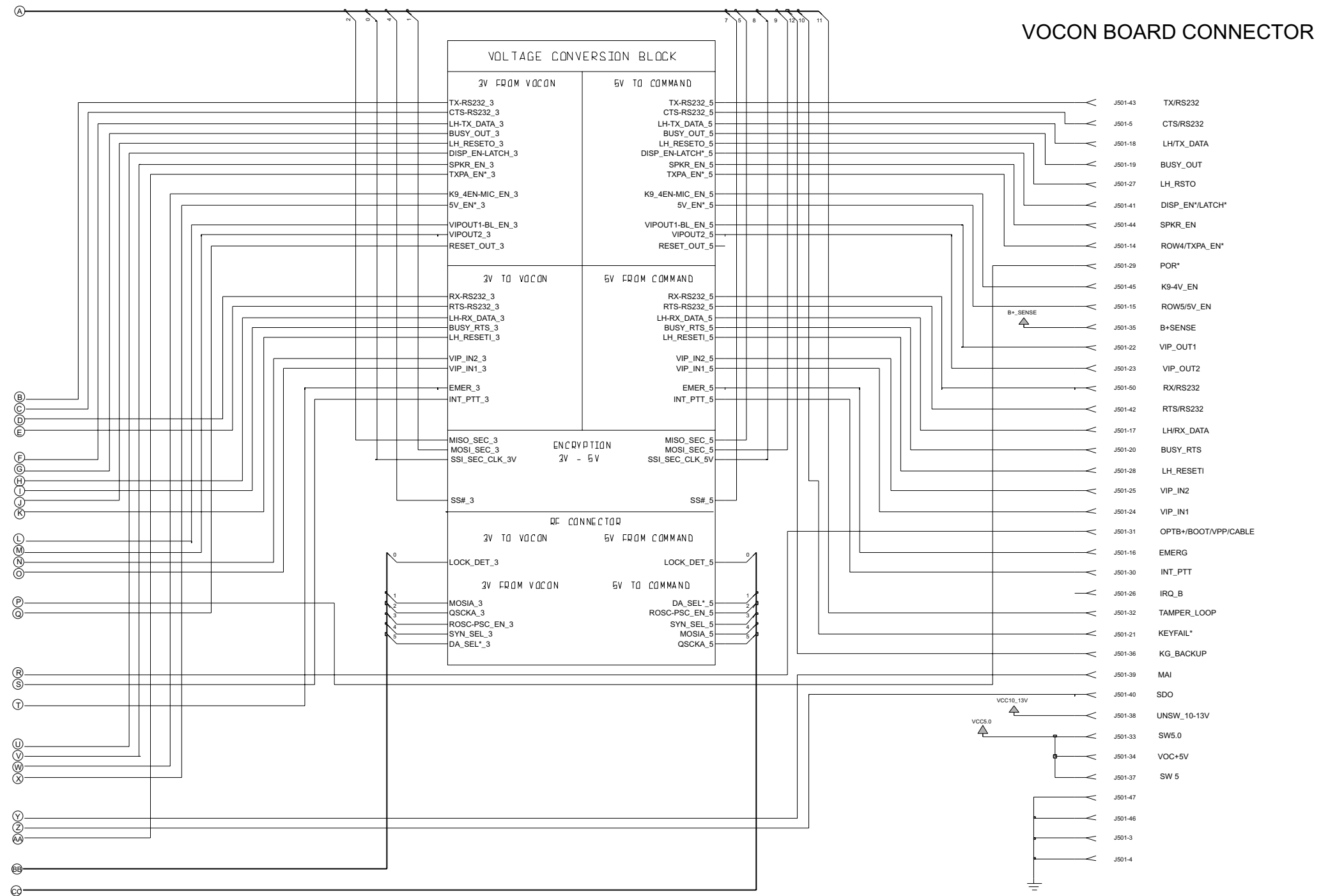

ASTRO Spectra Plus VOCON Top Level Schematic (Sheet 2 of 2)

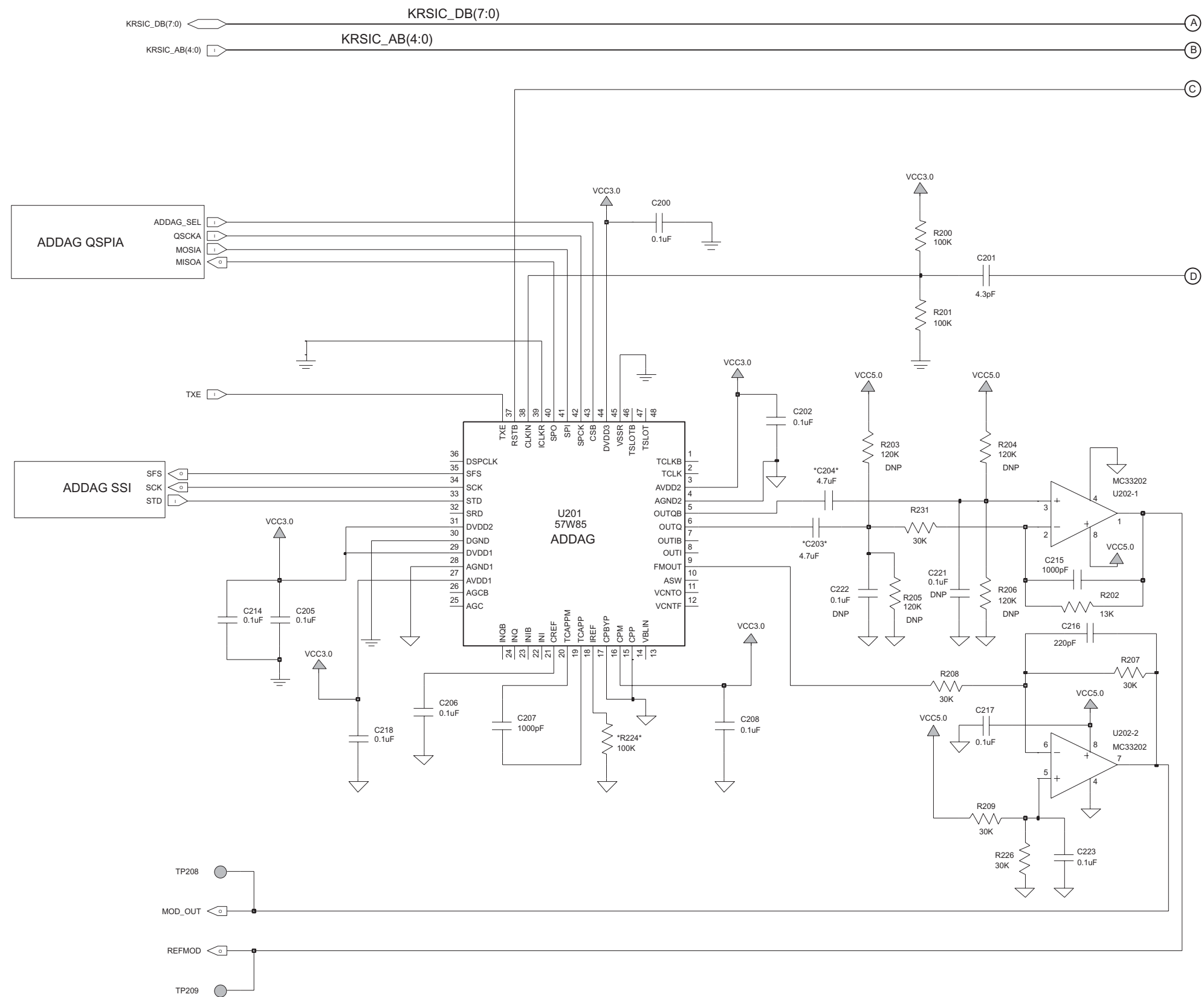

HLN6837A ASTRO Spectra Plus RF Interface Schematic (Sheet 1 of 2)

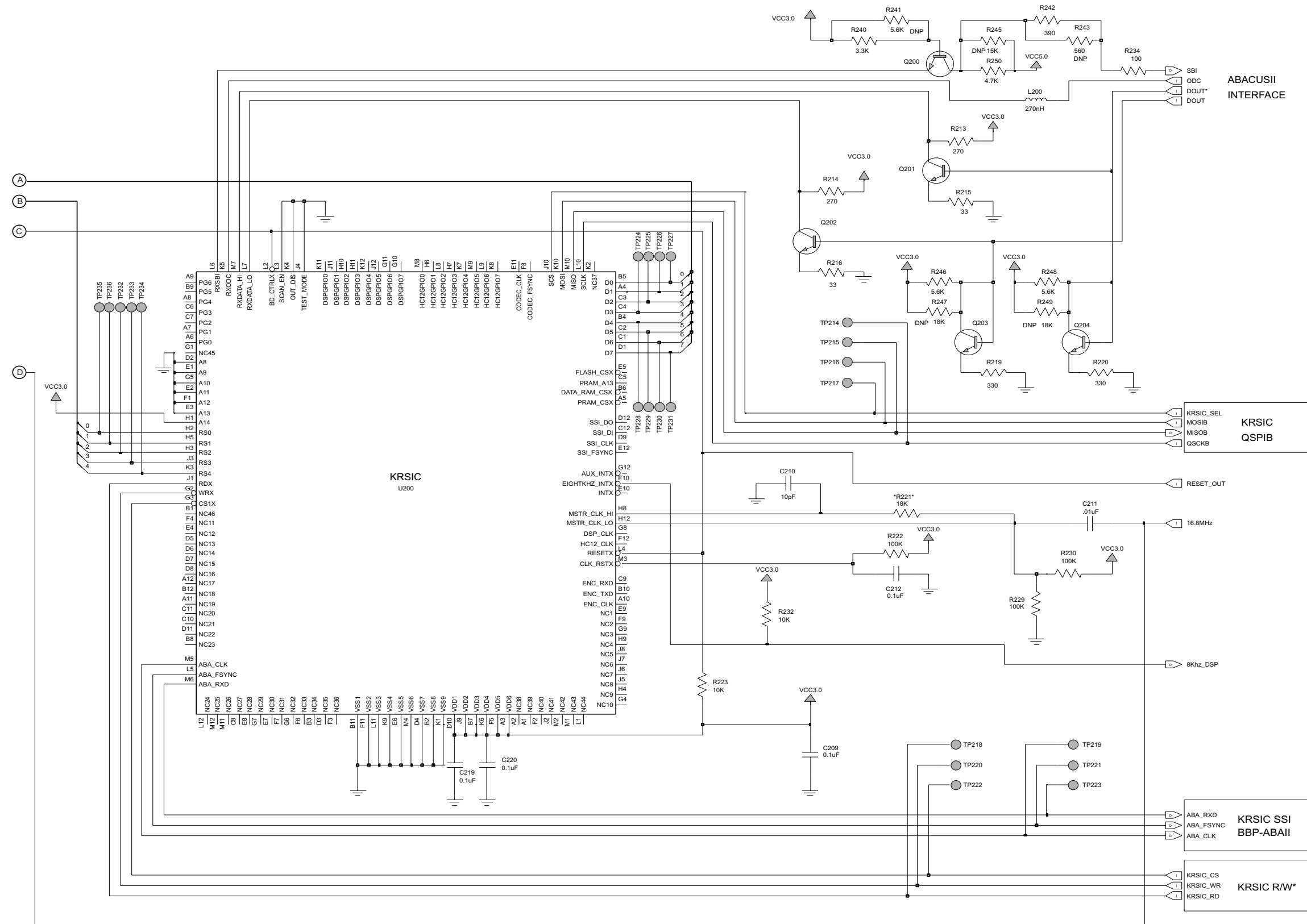

HLN6837A ASTRO Spectra Plus RF Interface Schematic (Sheet 2 of 2)

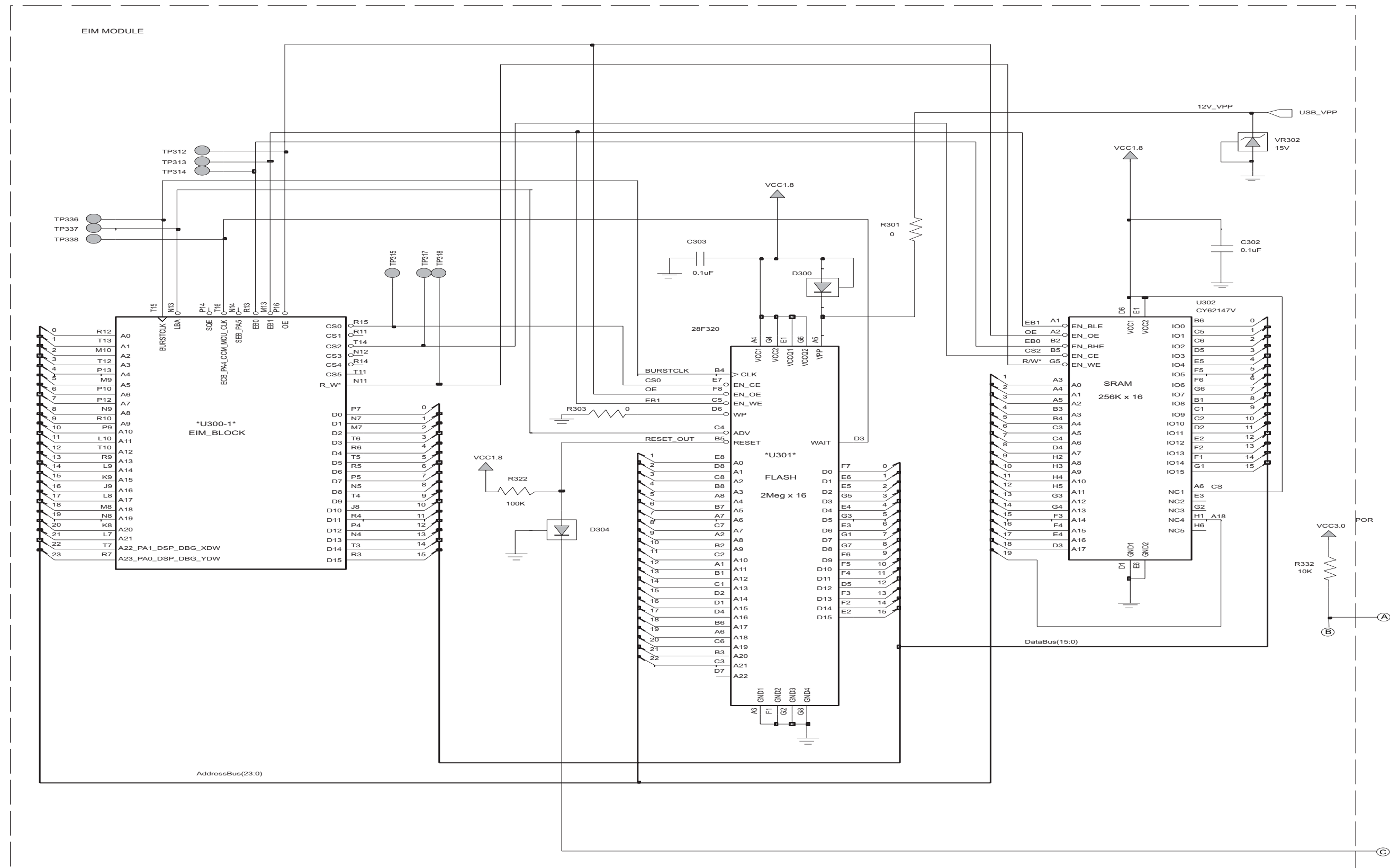

HLN6837A ASTRO Spectra Plus Digital/USB Schematic (Sheet 1 of 2)

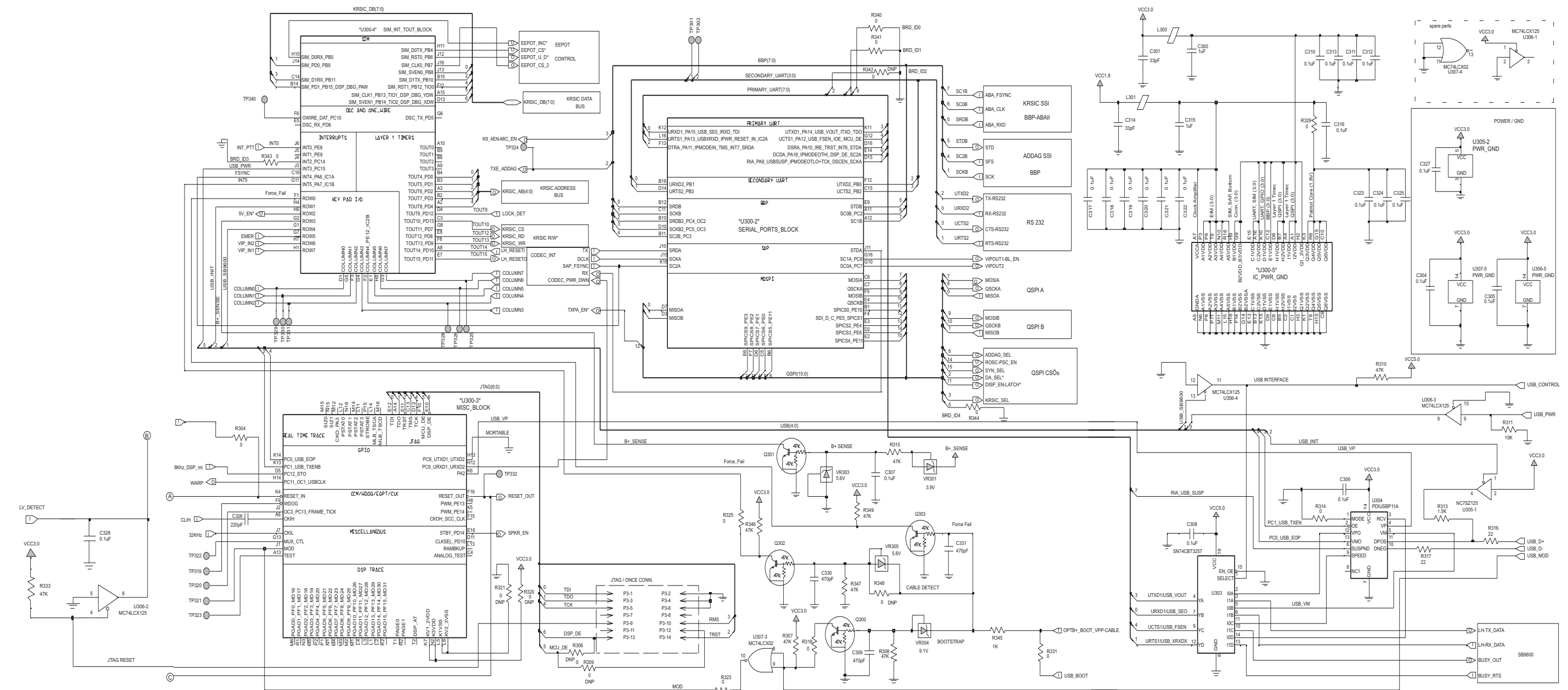

HLN6837A ASTRO Spectra Plus Digital/USB Schematic (Sheet 2 of 2)

AUDIO DC BLOCK

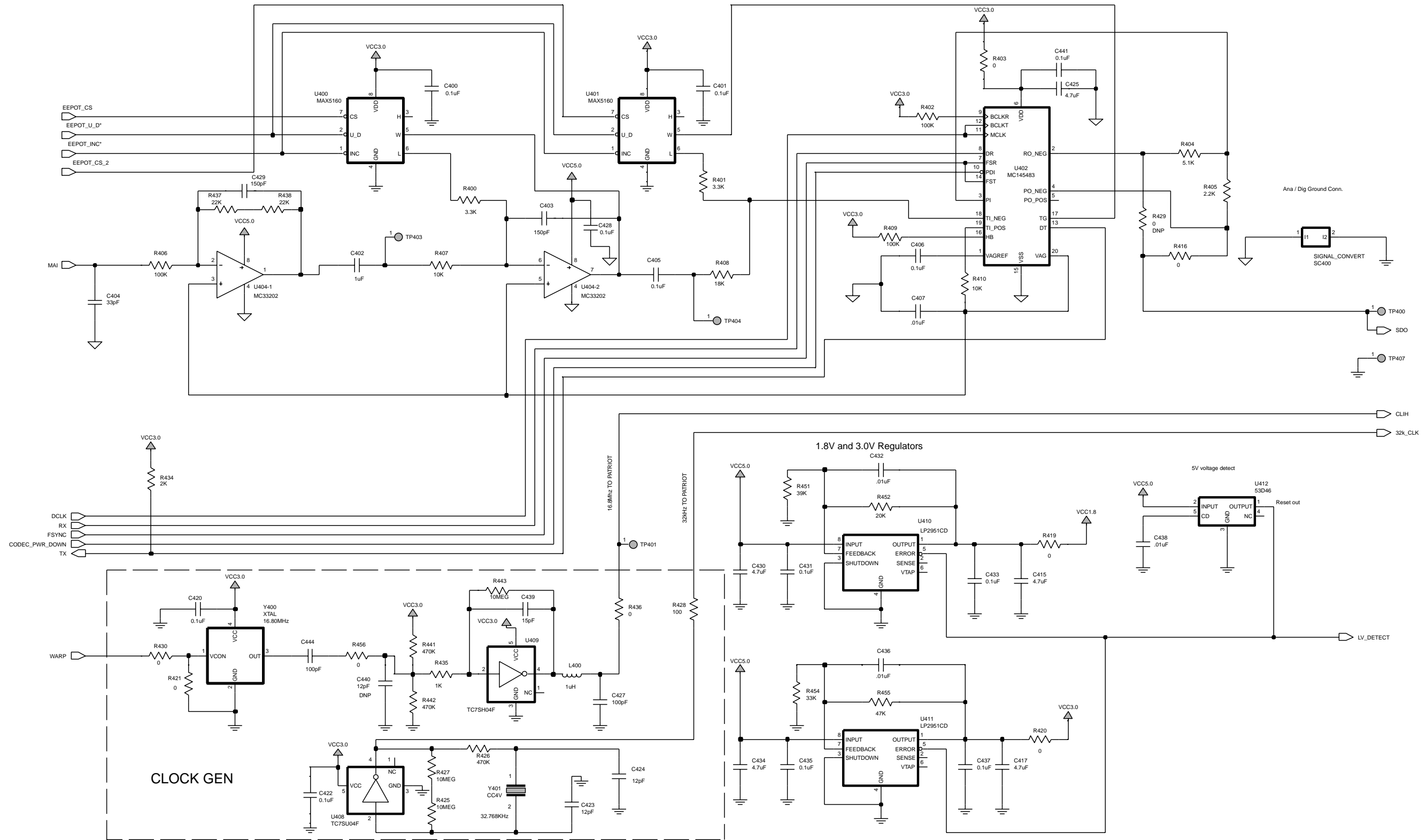

HLN6837A ASTRO Spectra Plus Audio/DC Schematic

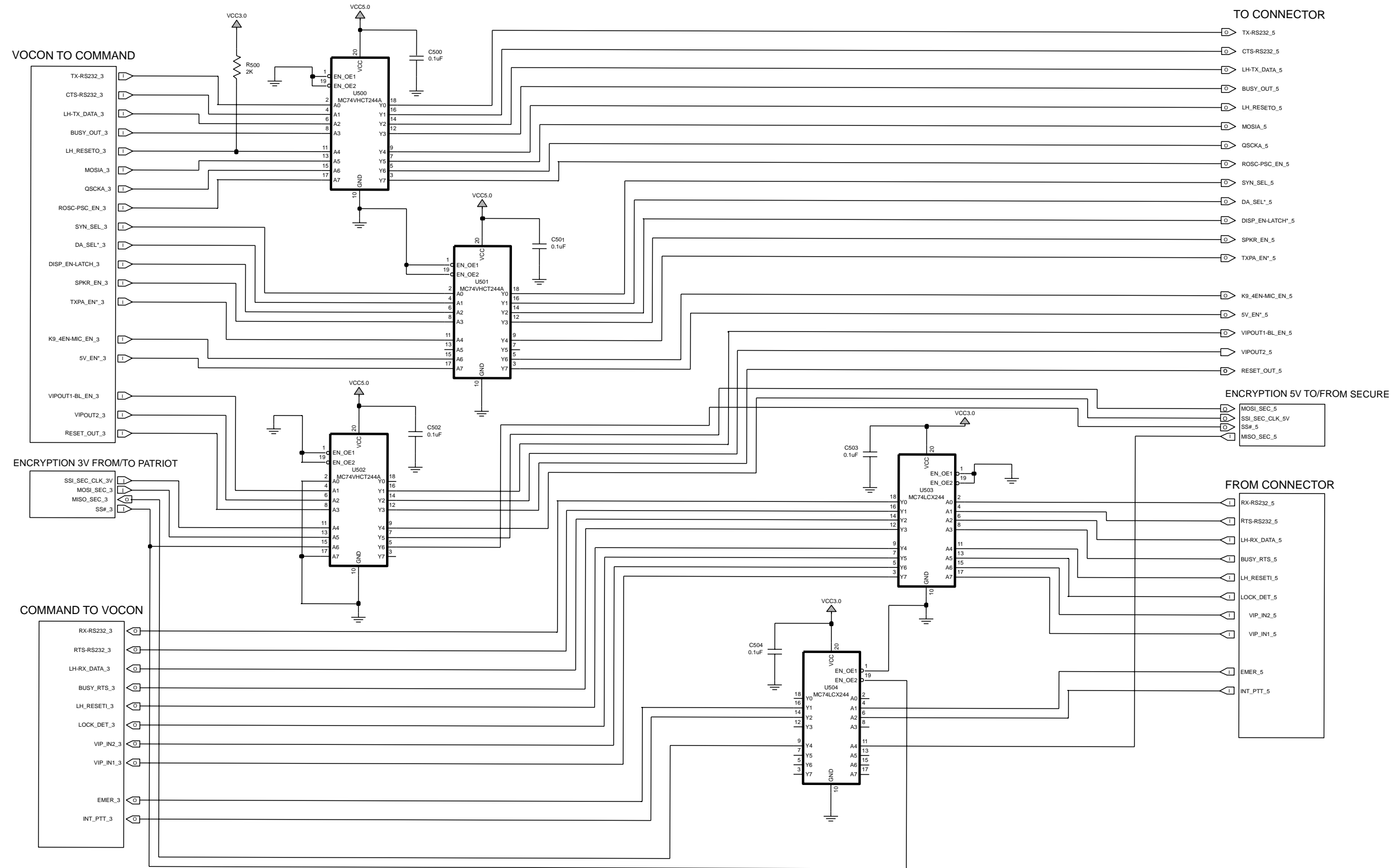

HLN6837A ASTRO Spectra Plus Voltage Conversion Schematic

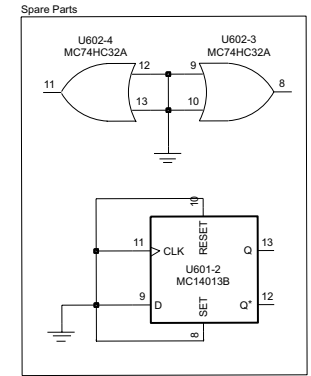
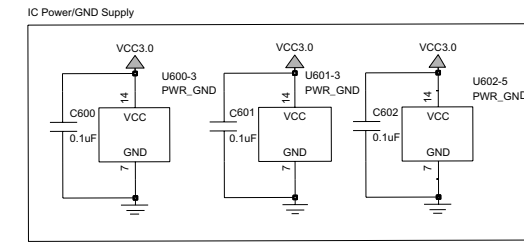
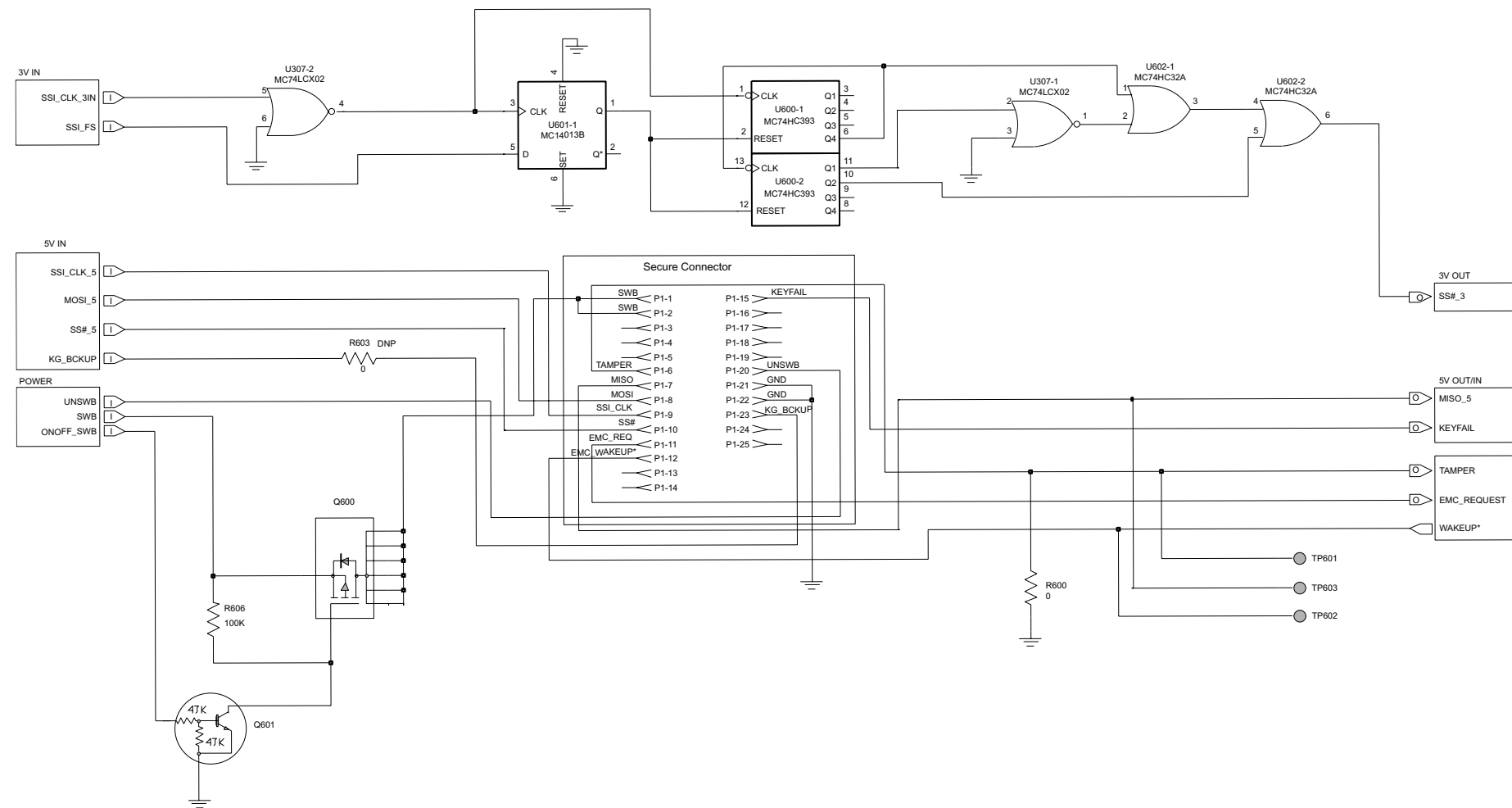

HLN6837A ASTRO Spectra Plus Secure Interface Schematic

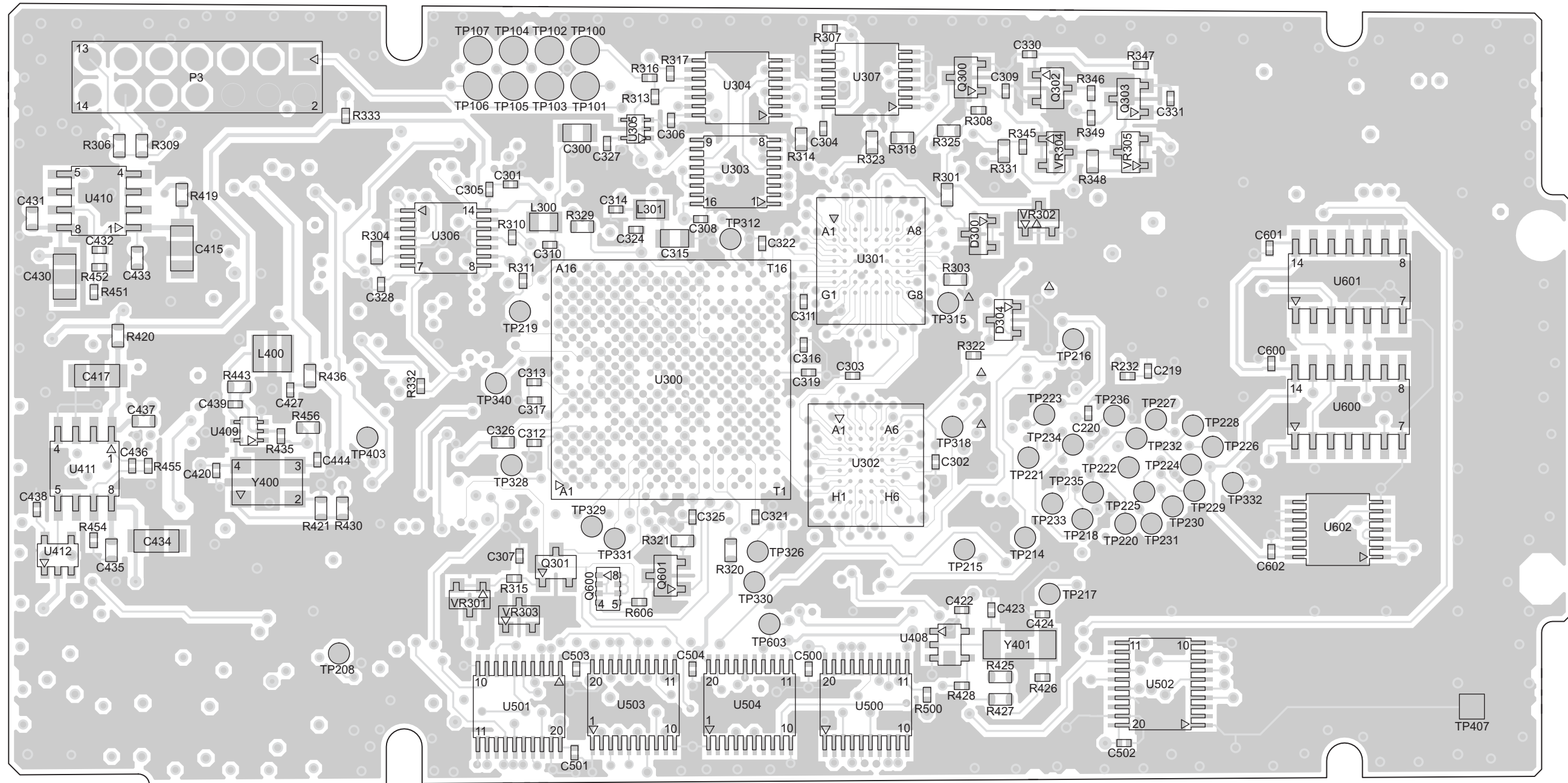

HLN6837A ASTRO Spectra Plus VOCON Component Location Diagram, Top View

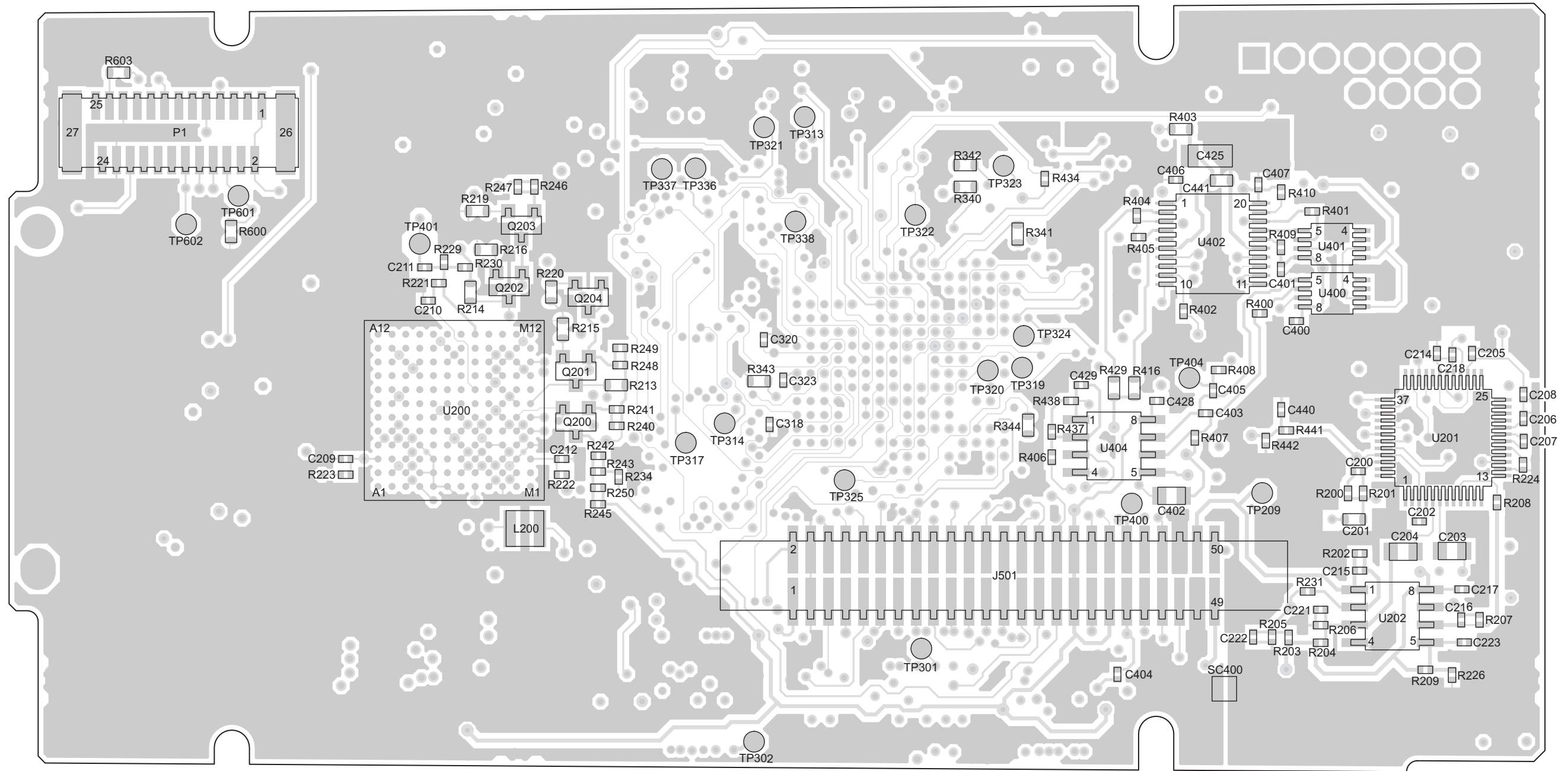

HLN6837A ASTRO Spectra Plus VOCON Component Location Diagram, Bottom View

HLN6837A ASTRO Spectra Plus VOCON Electrical Parts List

ITEM	MOTOROLA PART NUMBER	DESCRIPTION
C200	2113743M24	CAP CHIP 100000 PF +80-20% Y5V
C201	2113930F18	CAP 4.3 PF 50V +/- .25 PF 50V
C202	2113743M24	CAP CHIP 100000 PF +80-20% Y5V
C203	0662057C01	CHIP RES 0 OHMS +.050 OHMS
C204	0662057C01	CHIP RES 0 OHMS +.050 OHMS
C205	2113743M24	CAP CHIP 100000 PF +80-20% Y5V
C206	2113743M24	CAP CHIP 100000 PF +80-20% Y5V
C207	2113743L17	CAP CHIP 1000 PF 10% X7R
C208	2113743M24	CAP CHIP 100000 PF +80-20% Y5V
C209	2113743M24	CAP CHIP 100000 PF +80-20% Y5V
C210	2113743N26	CAP CHIP 10.0 PF 5% COG
C211	2113743L41	CAP CHIP 10000 PF 10% X7R
C212	2113743M24	CAP CHIP 100000 PF +80-20% Y5V
C214	2113743M24	CAP CHIP 100000 PF +80-20% Y5V
C215	2113743L33	CAP CHIP 4700 PF 10% X7R
C216	2113743L09	CAP CHIP 470 PF 10% X7R
C217	2113743M24	CAP CHIP 100000 PF +80-20% Y5V
C218	2113743M24	CAP CHIP 100000 PF +80-20% Y5V
C219	2113743M24	CAP CHIP 100000 PF +80-20% Y5V
C220	2113743M24	CAP CHIP 100000 PF +80-20% Y5V
C221 - C222	-----	NOTPLACED
C223	2113743M24	CAP CHIP 100000 PF +80-20% Y5V
C300	2113928E01	CAP CER CHIP 1.0 UF 10 % 10V
C301	2113743N38	CAP CHIP 33.0 PF 5% COG
C302	2113743M24	CAP CHIP 100000 PF +80-20% Y5V
C303	2113743M24	CAP CHIP 100000 PF +80-20% Y5V
C304	2113743M24	CAP CHIP 100000 PF +80-20% Y5V

ITEM	MOTOROLA PART NUMBER	DESCRIPTION
C305	2113743M24	CAP CHIP 100000 PF +80-20% Y5V
C306	2113743M24	CAP CHIP 100000 PF +80-20% Y5V
C307	2113743M24	CAP CHIP 100000 PF +80-20% Y5V
C308	2113743M24	CAP CHIP 100000 PF +80-20% Y5V
C309	2113743L09	CAP CHIP 470 PF 10% X7R
C310	2113743M24	CAP CHIP 100000 PF +80-20% Y5V
C311	2113743M24	CAP CHIP 100000 PF +80-20% Y5V
C312	2113743M24	CAP CHIP 100000 PF +80-20% Y5V
C313	2113743M24	CAP CHIP 100000 PF +80-20% Y5V
C314	2113743N38	CAP CHIP 33.0 PF 5% COG
C315	2113928E01	CAP CER CHIP 1.0 UF 10 % 10V
C316	2113743M24	CAP CHIP 100000 PF +80-20% Y5V
C317	2113743M24	CAP CHIP 100000 PF +80-20% Y5V
C318	2113743M24	CAP CHIP 100000 PF +80-20% Y5V
C319	2113743M24	CAP CHIP 100000 PF +80-20% Y5V
C320	2113743M24	CAP CHIP 100000 PF +80-20% Y5V
C321	2113743M24	CAP CHIP 100000 PF +80-20% Y5V
C322	2113743M24	CAP CHIP 100000 PF +80-20% Y5V
C323	2113743M24	CAP CHIP 100000 PF +80-20% Y5V
C324	2113743M24	CAP CHIP 100000 PF +80-20% Y5V
C325	2113743M24	CAP CHIP 100000 PF +80-20% Y5V
C326	2113930F59	CAP CER CHP 220 PF 50V 5%
C327	2113743M24	CAP CHIP 100000 PF +80-20% Y5V
C328	2113743M24	CAP CHIP 100000 PF +80-20% Y5V
C330	2113743L09	CAP CHIP 470 PF 10% X7R
C331	2113743L09	CAP CHIP 470 PF 10% X7R
C400	2113743M24	CAP CHIP 100000 PF +80-20% Y5V

ITEM	MOTOROLA PART NUMBER	DESCRIPTION
C401	2113743M24	CAP CHIP 100000 PF +80-20% Y5V
C402	2113928E01	CAP CER CHIP 1.0 UF 10 % 10V
C403	2113743N54	CAP CHIP 150 PF 5% COG
C404	2113743N38	CAP CHIP 33.0 PF 5% COG
C405	2113743M24	CAP CHIP 100000 PF +80-20% Y5V
C406	2113743M24	CAP CHIP 100000 PF +80-20% Y5V
C407	2113743L41	CAP CHIP 10000 PF 10% X7R
C415	2185802B01	CAP 10V 4.7UF
C417	2185802B01	CAP 10V 4.7UF
C420	2113743M24	CAP CHIP 100000 PF +80-20% Y5V
C422	2113743M24	CAP CHIP 100000 PF +80-20% Y5V
C423	2113743N28	CAP CHIP 12.0 PF 5% COG
C424	2113743N28	CAP CHIP 12.0 PF 5% COG
C425	2185802B01	CAP 10V 4.7UF
C427	2113743N50	CAP CHIP 100 PF 5% COG
C428	2113743M24	CAP CHIP 100000 PF +80-20% Y5V
C429	2113743N54	CAP CHIP 150 PF 5% COG
C430	2185802B01	CAP 10V 4.7UF
C431	2113932E20	CAP CER CHP .10 UF 10% 16V
C432	2113743L41	CAP CHIP 10000 PF 10% X7R
C433	2113932E20	CAP CER CHP .10 UF 10% 16V
C434	2185802B01	CAP 10V 4.7UF
C435	2113932E20	CAP CER CHP .10 UF 10% 16V
C436	2113743L41	CAP CHIP 10000 PF 10% X7R
C437	2113932E20	CAP CER CHP .10 UF 10% 16V
C438	2113743L41	CAP CHIP 10000 PF 10% X7R
C439	2113743N30	CAP CHIP 15.0 PF 5% COG
C440		NOTPLACED
C441	2113932E20	CAP CER CHP .10 UF 10% 16V
C444	2113743N50	CAP CHIP 100 PF 5% COG
C500	2113743M24	CAP CHIP 100000 PF +80-20% Y5V
C501	2113743M24	CAP CHIP 100000 PF +80-20% Y5V
C502	2113743M24	CAP CHIP 100000 PF +80-20% Y5V
C503	2113743M24	CAP CHIP 100000 PF +80-20% Y5V
C504	2113743M24	CAP CHIP 100000 PF +80-20% Y5V

ITEM	MOTOROLA PART NUMBER	DESCRIPTION
C600	2113743M24	CAP CHIP 100000 PF +80-20% Y5V
C601	2113743M24	CAP CHIP 100000 PF +80-20% Y5V
C602	2113743M24	CAP CHIP 100000 PF +80-20% Y5V
D300	4805129M90	DIODE SOT PKGD
D304	4805129M90	DIODE SOT PKGD
J501	0905516W02	CONN RECEPTACLE
L200	2462587N58	CHIP IND 270 NH 5%
L300	2480067M02	CHK RF CHIP BEAD INDUCTOR
L301	2480067M02	CHK RF CHIP BEAD INDUCTOR
L400	2462587N68	CHIP IND 1000 NH 5%
P1	0913915A11	RECP SMT LOPRO 25 POS
P3		NOTPLACED
PCB	8485146D01	PCB, ASTRO/SPECTRA PLUS VOCON
Q200	4813824A10	TSTR NPN 40V .2A GEN PURP
Q201	4805128M12	TSTR SOT BCW 60B (RH)
Q202	4805128M12	TSTR SOT BCW 60B (RH)
Q203	4805128M12	TSTR SOT BCW 60B (RH)
Q204	4805128M12	TSTR SOT BCW 60B (RH)
Q300	4880048M01	TSTR NPN DIG 47K/47K
Q301	4880048M01	TSTR NPN DIG 47K/47K
Q302	4880048M01	TSTR NPN DIG 47K/47K
Q303	4880048M01	TSTR NPN DIG 47K/47K
Q600	4885844C02	XSTR P-CH MOSFET 30V 80MOHM@4.5V
Q601	4880048M01	TSTR NPN DIG 47K/47K
R200	0662057N23	RES. CHIP 100K 5% 20X40
R201	0662057N23	RES. CHIP 100K 5% 20X40
R202	0662057M81	RES. CHIP 2000 5% 20X40
R203 - R206	-----	NOTPLACED
R207	0662057N05	RES. CHIP 18K 5% 20X40
R208	0662057N10	RES. CHIP 30K 5% 20X40
R209	0662057N10	RES. CHIP 30K 5% 20X40
R213	0662057A35	CHIP RES 270 OHMS 5%
R214	0662057A35	CHIP RES 270 OHMS 5%
R215	0662057A13	CHIP RES 33 OHMS 5%
R216	0662057A13	CHIP RES 33 OHMS 5%
R219	0662057A37	CHIP RES 330 OHMS 5%
R220	0662057A37	CHIP RES 330 OHMS 5%
R221	0662057N05	RES. CHIP 18K 5% 20X40
R222	0662057N23	RES. CHIP 100K 5% 20X40

ITEM	MOTOROLA PART NUMBER	DESCRIPTION
R223	0662057M98	RES. CHIP 10K 5% 20X40
R224	0662057N23	RES. CHIP 100K 5% 20X40
R226	0662057N10	RES. CHIP 30K 5% 20X40
R229	0662057N23	RES. CHIP 100K 5% 20X40
R230	0662057N23	RES. CHIP 100K 5% 20X40
R231	0662057N10	RES. CHIP 30K 5% 20X40
R232	0662057M98	RES. CHIP 10K 5% 20X40
R234	0662057M50	RES. CHIP 100 5% 20X40
R240	0662057M86	RES. CHIP 3300 5X 20X40
R241	-----	NOTPLACED
R242	0662057M64	RES. CHIP 390 5% 20X40
R243	-----	NOTPLACED
R245 - R249	-----	NOTPLACED
R250	0662057M90	RES. CHIP 4700 5% 20X40
R301	0662057B47	CHIP RES 0 OHMS +/-0.050 OHMS
R303	0662057B47	CHIP RES 0 OHMS +/-0.050 OHMS
R304	0662057B47	CHIP RES 0 OHMS +/-0.050 OHMS
R306	-----	NOTPLACED
R307	0662057N15	RES. CHIP 47K 5% 20X40
R308	0662057N15	RES. CHIP 47K 5% 20X40
R309		NOTPLACED
R310	0662057N15	RES. CHIP 47K 5% 20X40
R311	0662057M98	RES. CHIP 10K 5% 20X40
R313	0662057M78	RES. CHIP 1500 5% 20X40
R314	0662057B47	CHIP RES 0 OHMS +/-0.050 OHMS
R315	0662057N15	RES. CHIP 47K 5% 20X40
R316	0662057M34	RES. CHIP 22 5% 20X40
R317	0662057M34	RES. CHIP 22 5% 20X40
R318	0662057B47	CHIP RES 0 OHMS +/-0.050 OHMS
R320 - R321	-----	NOTPLACED
R322	0662057N23	RES. CHIP 100K 5% 20X40
R323	0662057B47	CHIP RES 0 OHMS +/-0.050 OHMS
R325	0662057B47	CHIP RES 0 OHMS +/-0.050 OHMS
R329	0662057B47	CHIP RES 0 OHMS +/-0.050 OHMS
R331	0662057B47	CHIP RES 0 OHMS +/-0.050 OHMS

ITEM	MOTOROLA PART NUMBER	DESCRIPTION
R332	0662057M98	RES. CHIP 10K 5% 20X40
R333	0662057N15	RES. CHIP 47K 5% 20X40
R340	0662057B47	CHIP RES 0 OHMS +/-0.050 OHMS
R341	0662057B47	CHIP RES 0 OHMS +/-0.050 OHMS
R342	-----	NOTPLACED
R343	0662057B47	CHIP RES 0 OHMS +/-0.050 OHMS
R344	0662057B47	CHIP RES 0 OHMS +/-0.050 OHMS
R345	0662057M74	RES. CHIP 1000 5% 20X40
R346	0662057N15	RES. CHIP 47K 5% 20X40
R347	0662057N15	RES. CHIP 47K 5% 20X40
R348	-----	NOTPLACED
R349	0662057N15	RES. CHIP 47K 5% 20X40
R400	0662057M86	RES. CHIP 3300 5X 20X40
R401	0662057M86	RES. CHIP 3300 5X 20X40
R402	0662057N23	RES. CHIP 100K 5% 20X40
R403	0662057B47	CHIP RES 0 OHMS +/-0.050 OHMS
R404	0662057M91	RES CHIP 5100 5% 20X40
R405	0662057M82	RES. CHIP 2200 5% 20X40
R406	0662057N23	RES. CHIP 100K 5% 20X40
R407	0662057M98	RES. CHIP 10K 5% 20X40
R408	0662057N05	RES. CHIP 18K 5% 20X40
R409	0662057N23	RES. CHIP 100K 5% 20X40
R410	0662057M98	RES. CHIP 10K 5% 20X40
R416	0662057B47	CHIP RES 0 OHMS +/-0.050 OHMS
R419	0662057B47	CHIP RES 0 OHMS +/-0.050 OHMS
R420	0662057B47	CHIP RES 0 OHMS +/-0.050 OHMS
R421	0662057B47	CHIP RES 0 OHMS +/-0.050 OHMS
R425	0662057B46	CHIP RES 10.0 MEG OHMS 5%
R426	0662057N39	RES. CHIP 470K 5% 20X40
R427	0662057B46	CHIP RES 10.0 MEG OHMS 5%
R428	0662057M50	RES. CHIP 100 5% 20X40
R429	-----	NOTPLACED
R430	0662057B47	CHIP RES 0 OHMS +/-0.050 OHMS
R434	0662057M81	RES. CHIP 2000 5% 20X40
R435	0662057M74	RES. CHIP 1000 5% 20X40

ITEM	MOTOROLA PART NUMBER	DESCRIPTION
R436	0662057B47	CHIP RES 0 OHMS +/-0.050 OHMS
R437	0662057N07	RES. CHIP 22K 5% 20X40
R438	0662057N07	RES. CHIP 22K 5% 20X40
R441	0662057N39	RES. CHIP 470K 5% 20X40
R442	0662057N39	RES. CHIP 470K 5% 20X40
R443	0662057B46	CHIP RES 10.0 MEG OHMS 5%
R451	0662057N13	RES. CHIP 39K 5% 20X40
R452	0662057N06	RES. CHIP 20K 5% 20X40
R454	0662057N11	RES. CHIP 33K 5% 20X40
R455	0662057N15	RES. CHIP 47K 5% 20X40
R456	0662057B47	CHIP RES 0 OHMS +/-0.050 OHMS
R500	0662057M81	RES. CHIP 2000 5% 20X40
R600	0662057B47	CHIP RES 0 OHMS +/-0.050 OHMS
R603	-----	NOTPLACED
R606	0662057N23	RES. CHIP 100K 5% 20X40
SC400	-----	NOTPLACED
U200	5185963A50	IC CMOS KRSIC
U201	5105457W85	CC ADDAG IC
U202	5113818A14	IC DL OP AMP RAIL TO RAIL
U300	5109841C69	IC 256 BGA 17X17 PACKAGE PATRIOT
U301	5185368C95	IC BURST FLASH 32MB
U302	5185130C38	IC SRAM 4MG
U303	5105109Z31	IC QUAD 2:1 MUX/DEMUX
U304	5185368C53	IC USB TRANSCEIVER 14 PIN TSSOP14
U305	5109522E53	IC SNGL BUF NC7S125P5X SC70
U306	5113837A15	IC 3.3V QUAD BUFFER
U307	5113837A02	IC NOR QUAD 2 IN MC 74LCX02DTR
U400	5185368C55	ICDIGITAL EEPOT 8 PIN S08
U401	5185368C55	ICDIGITAL EEPOT 8 PIN S08
U402	5105109Z38	3 VOLT LINEAR PCM CODEC FILTER
U404	5113818A14	IC DL OP AMP RAIL TO RAIL
U408	5185623B01	HIGH SPEED CMOS INVERTER
U409	5185353D93	IC AHCMOS SINGER GATE BUFFERED INVERTER
U410	5185353D55	IC VOLTAGE REGULATOR 100MZ ADJ
U411	5185353D55	IC VOLTAGE REGULATOR 100MZ ADJ

ITEM	MOTOROLA PART NUMBER	DESCRIPTION
U412	5185353D46	IF 4.3V VOLTAGE DETECTOR
U500	5113805C01	IC LN DRVR/RCVR 3V
U501	5113805C01	IC LN DRVR/RCVR 3V
U502	5113805C01	IC LN DRVR/RCVR 3V
U503	5113837A07	IC LINE DRVR OCT3 MC74LCX244DT
U504	5113837A07	IC LINE DRVR OCT3 MC74LCX244DT
U600	5113805B16	IC CNTR DL 4 STAGE BIN HC393D
U601	5113806A05	IC FLIP-FLOP,DUAL D
U602	5113805B44	IC OR QUAD 2-IN
VR301	4813830A11	DIODE 3.9V 5% 225MW MMBZ5228B_
VR302	4813830A28	DIODE 15V 5% 225MW MMBZ5245B_
VR303	4813830A15	DIODE 5.6V 5% 225MW MMBZ5232B_
VR304	4813830A22	DIODE 9.1V 5% 225MW MMBZ5239B_
VR305	4813830A15	DIODE 5.6V 5% 225MW MMBZ5232B_
Y400	4885071E01	MODULE REFERENCE OSCILLATOR 16.8 MHZ 5X3.2 MM
Y401	4809995L05	XTAL QUARTZ 32.768KHZ CC4V-T1

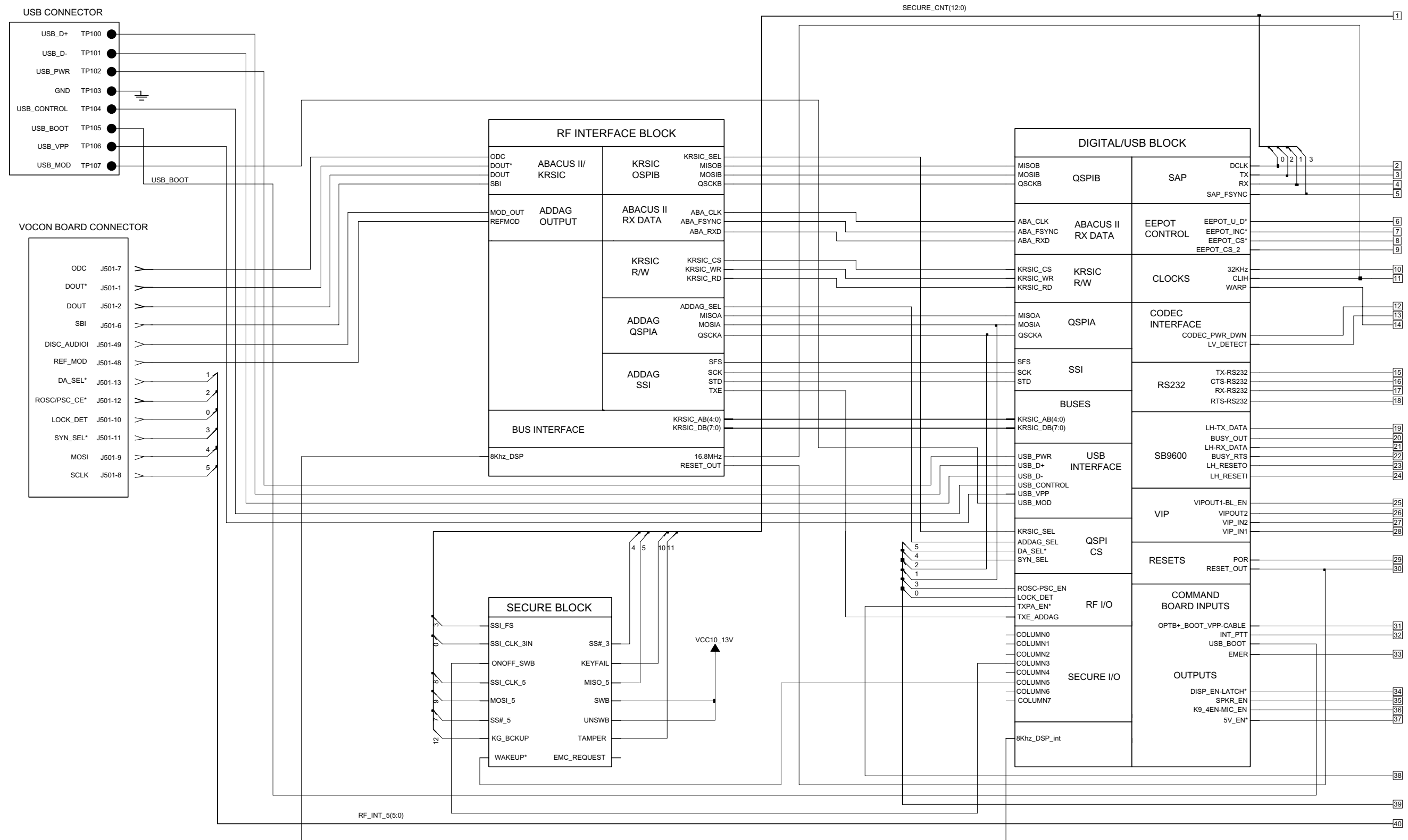

63B81096C39-O
SHEET 1

HLN6837C ASTRO Spectra Plus VOCON Top Level Schematic (Sheet 1 of 2)

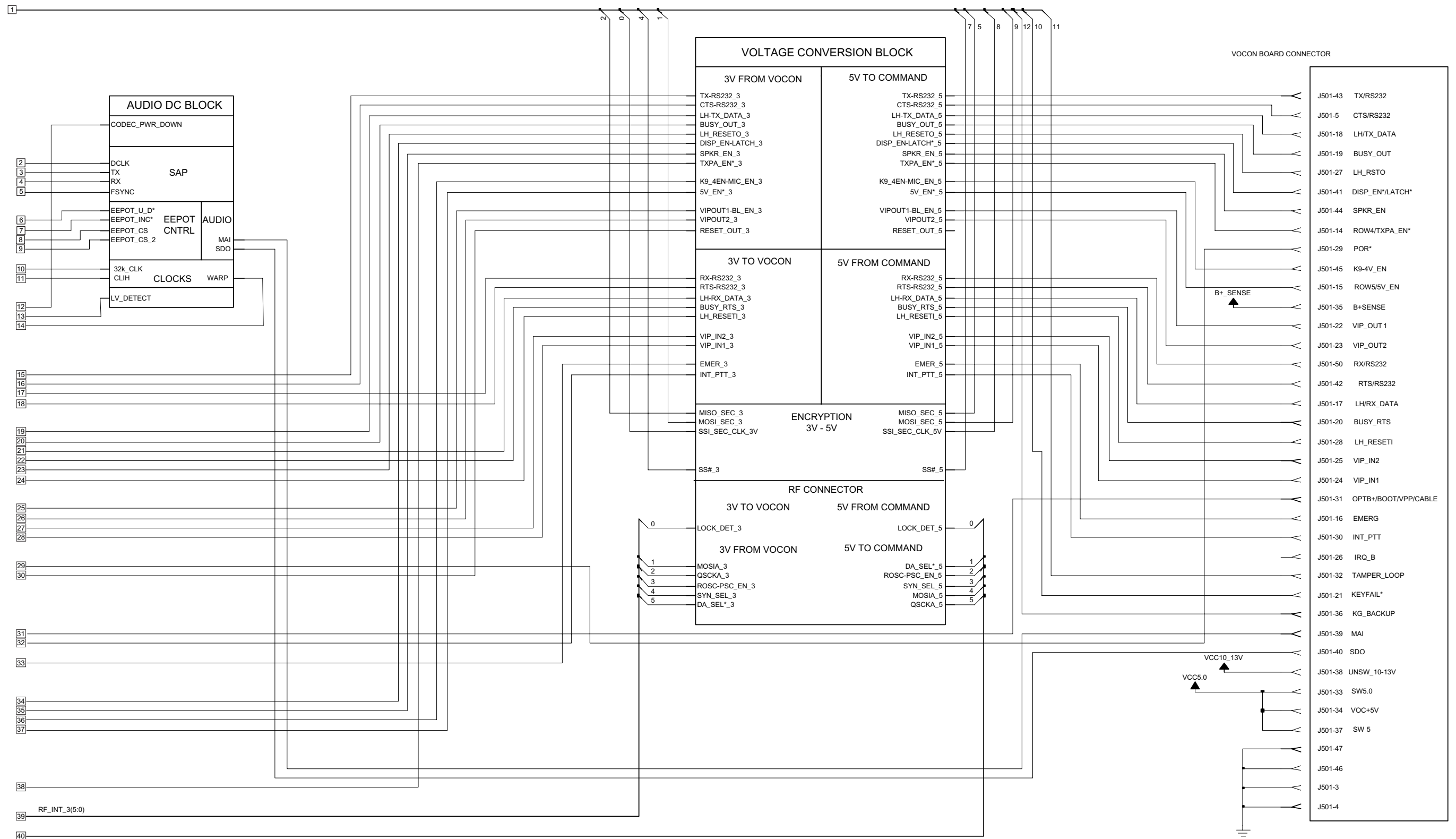

63B81096C39-0 SHEET 2

HLN6837C ASTRO Spectra Plus VOCON Top Level Schematic (Sheet 2 of 2)

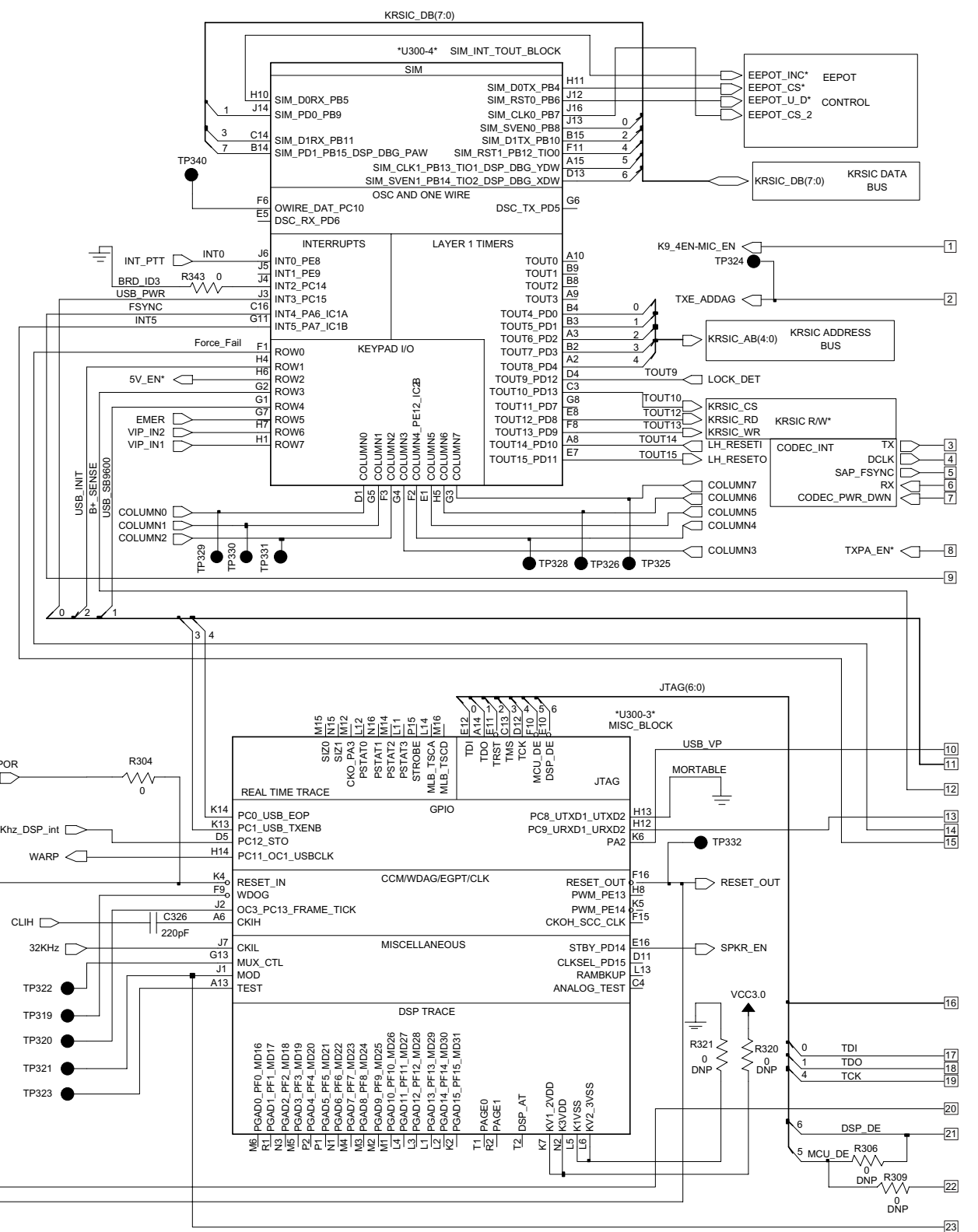
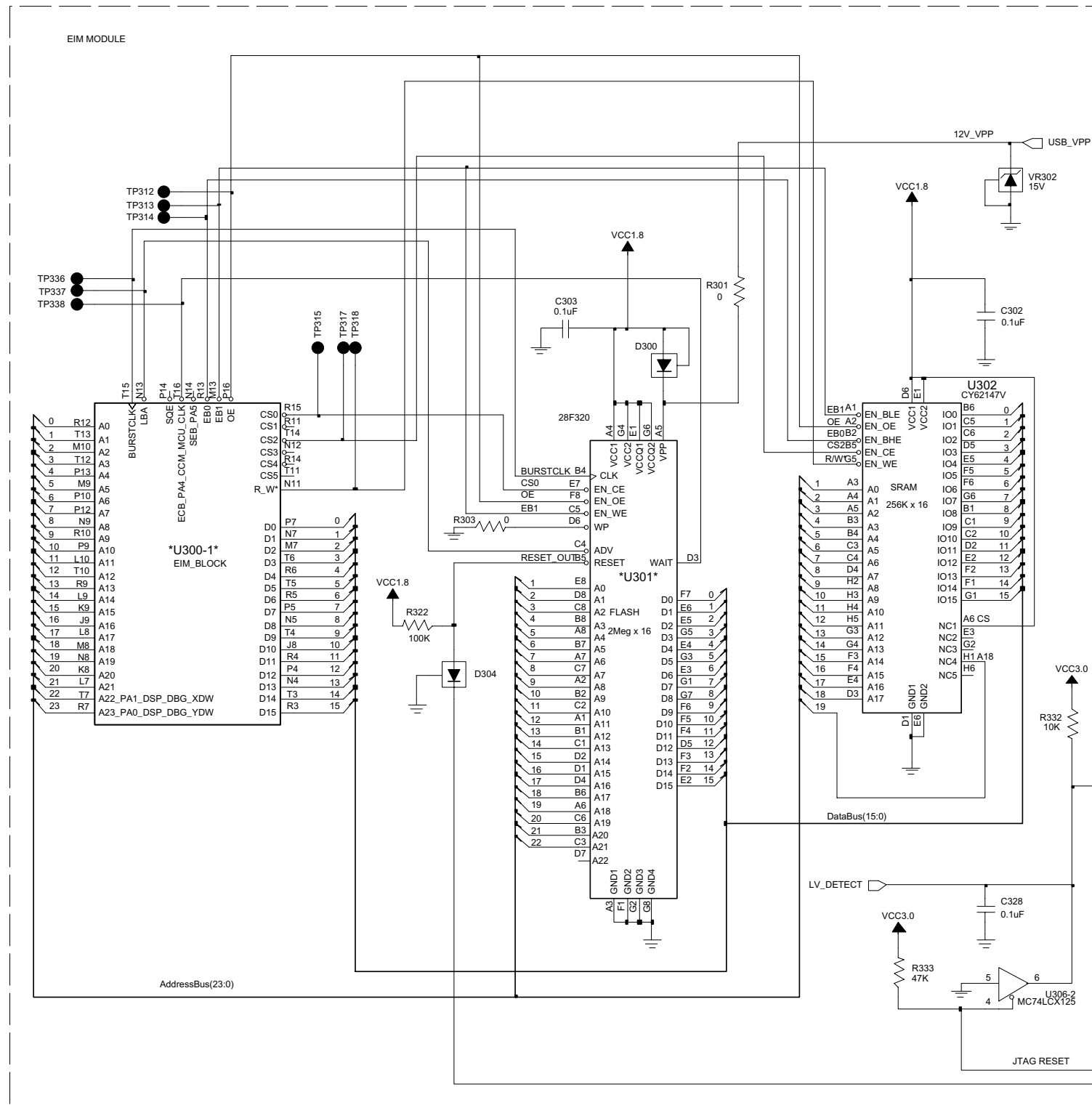

HLN6837C ASTRO Spectra Plus Digital/Memory Schematic (Sheet 1 of 2)

63B81096C42-0 SHEET 1

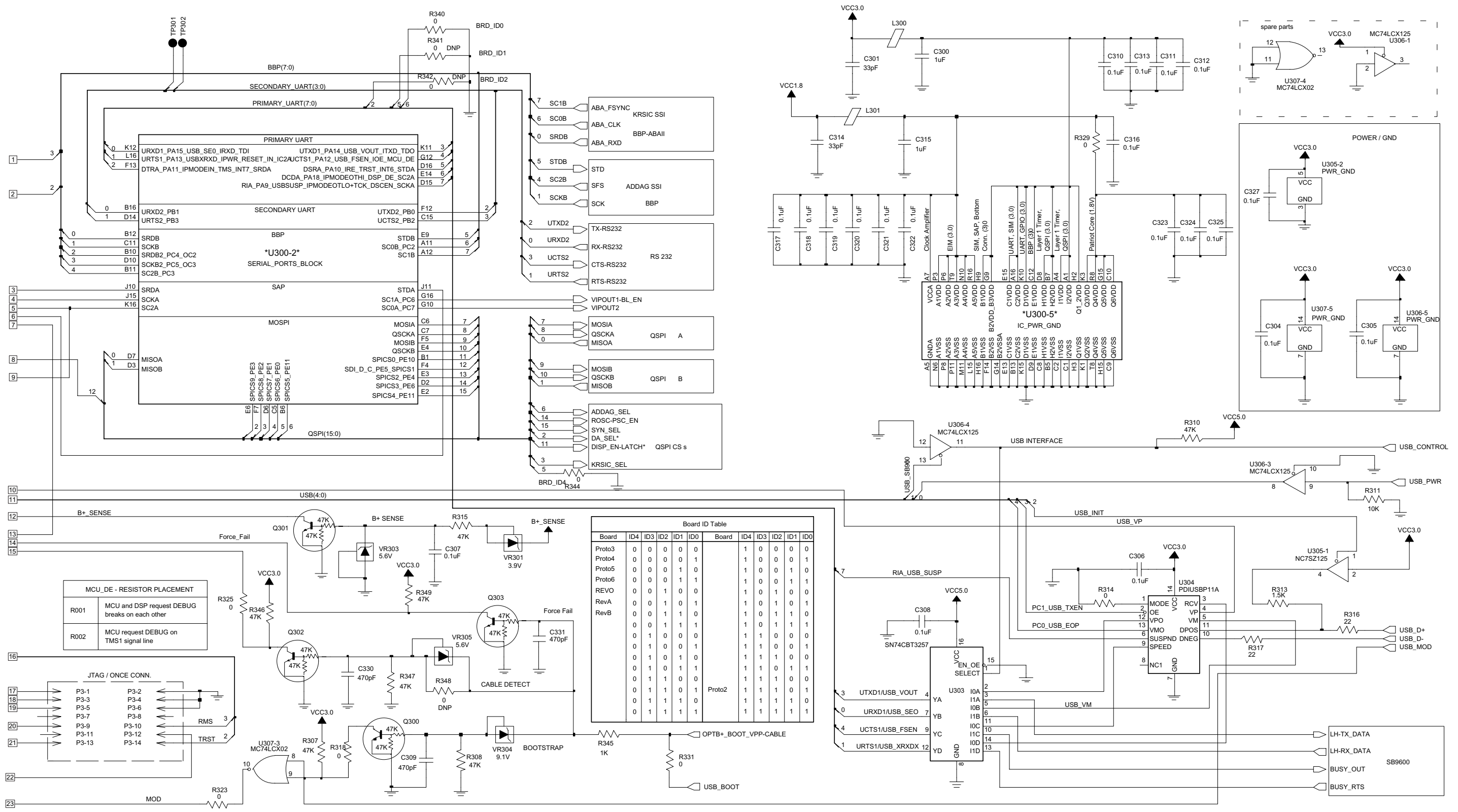

HLN6837C ASTRO Spectra Plus Digital/Memory Schematic (Sheet 2 of 2)

AUDIO DC BLOCK DISCRETE

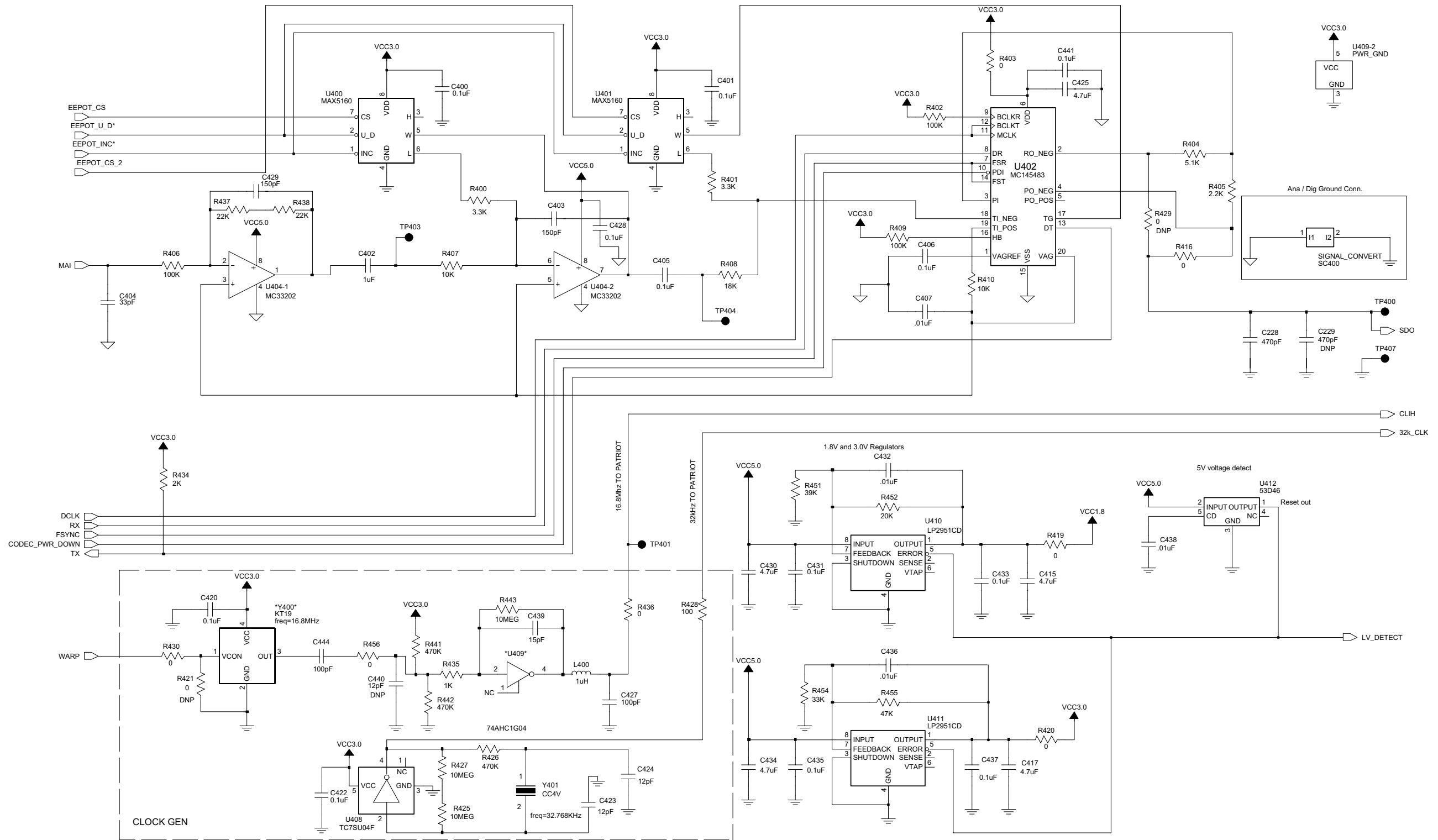

63B81096C44-O

HLN6837C ASTRO Spectra Plus Audio/DC Discrete Schematic

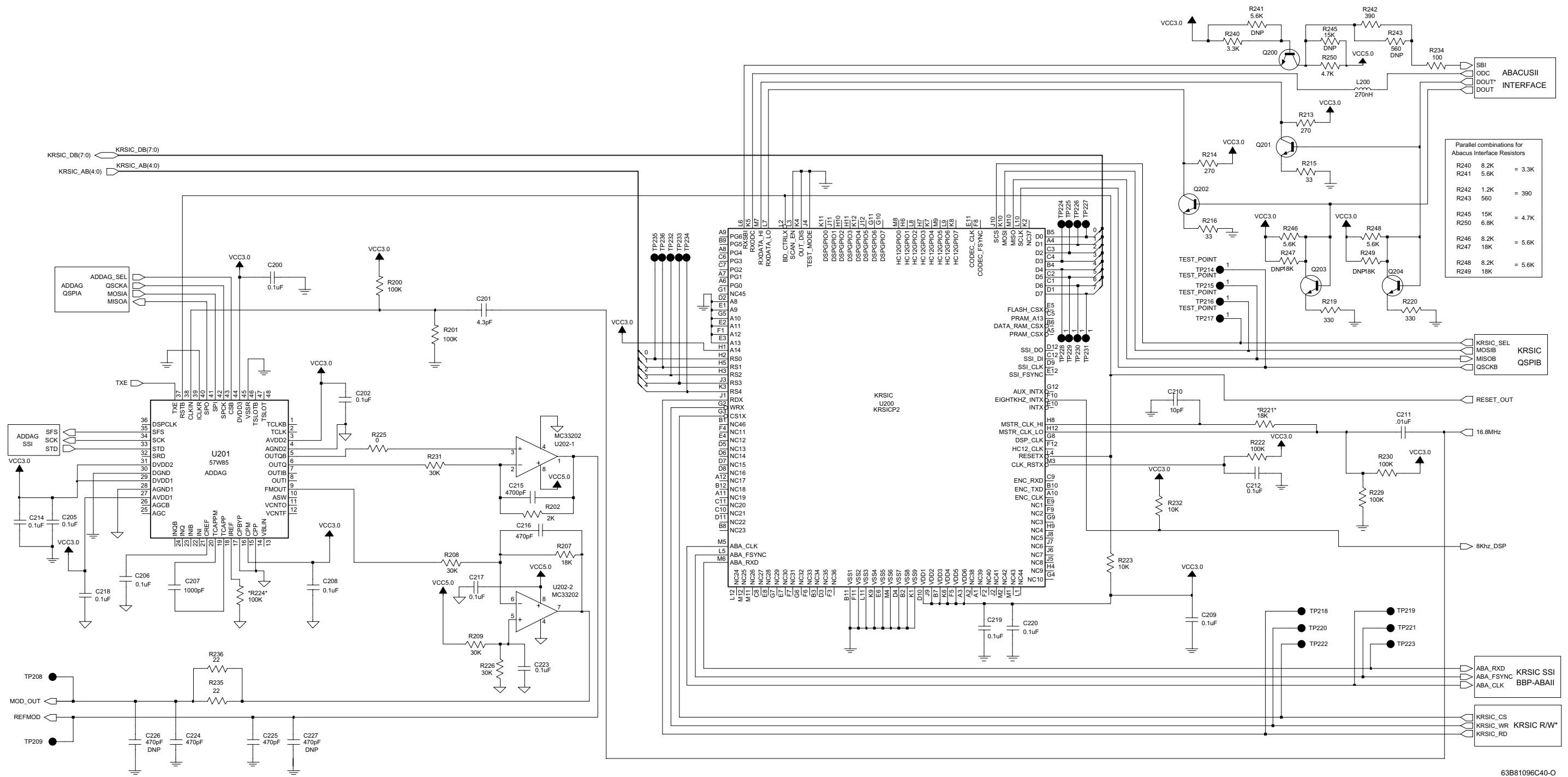

63B81096C40-0

HLN6837C ASTRO Spectra Plus RF Interface Schematic

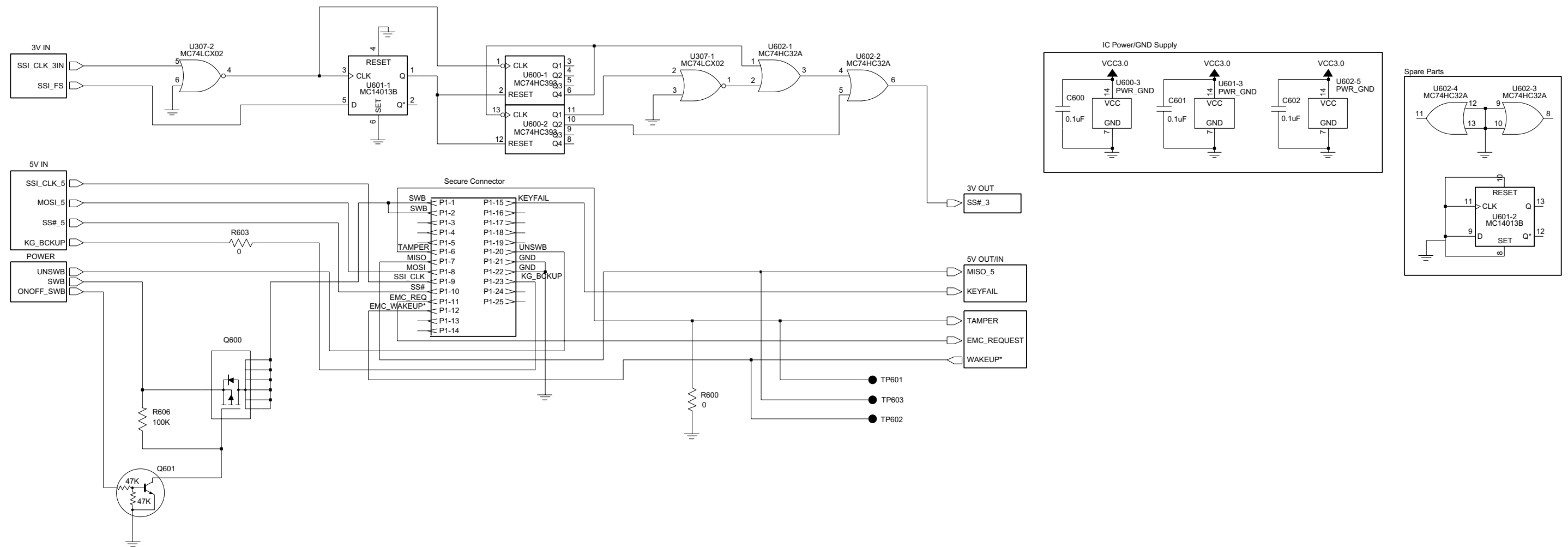

63B81096C41-0

HLN6837C ASTRO Spectra Plus Secure Schematic

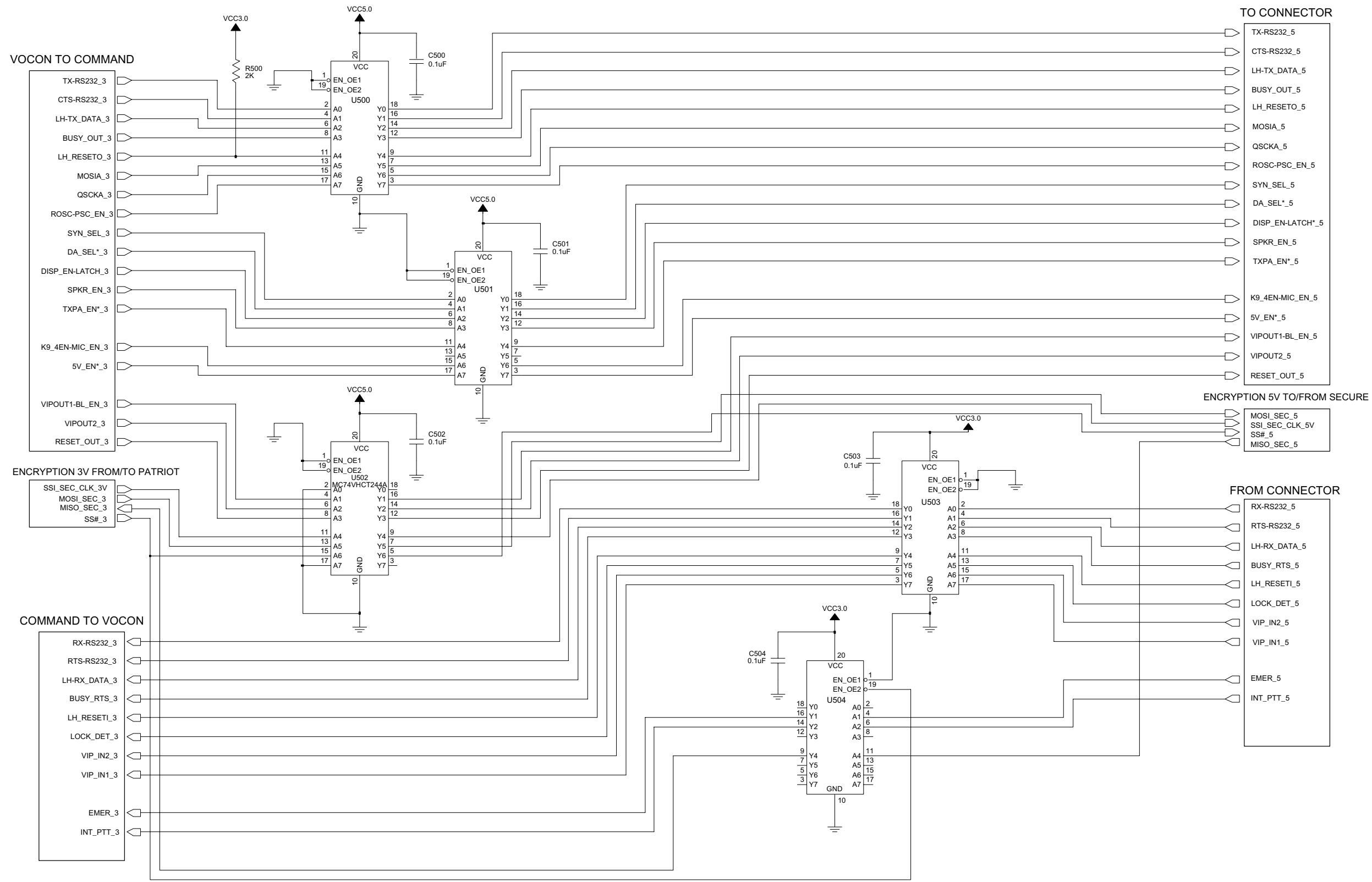

63B81096C45-0

HLN6837C ASTRO Spectra Plus VTrans/USB Schematic

VIEWED FROM SIDE 1

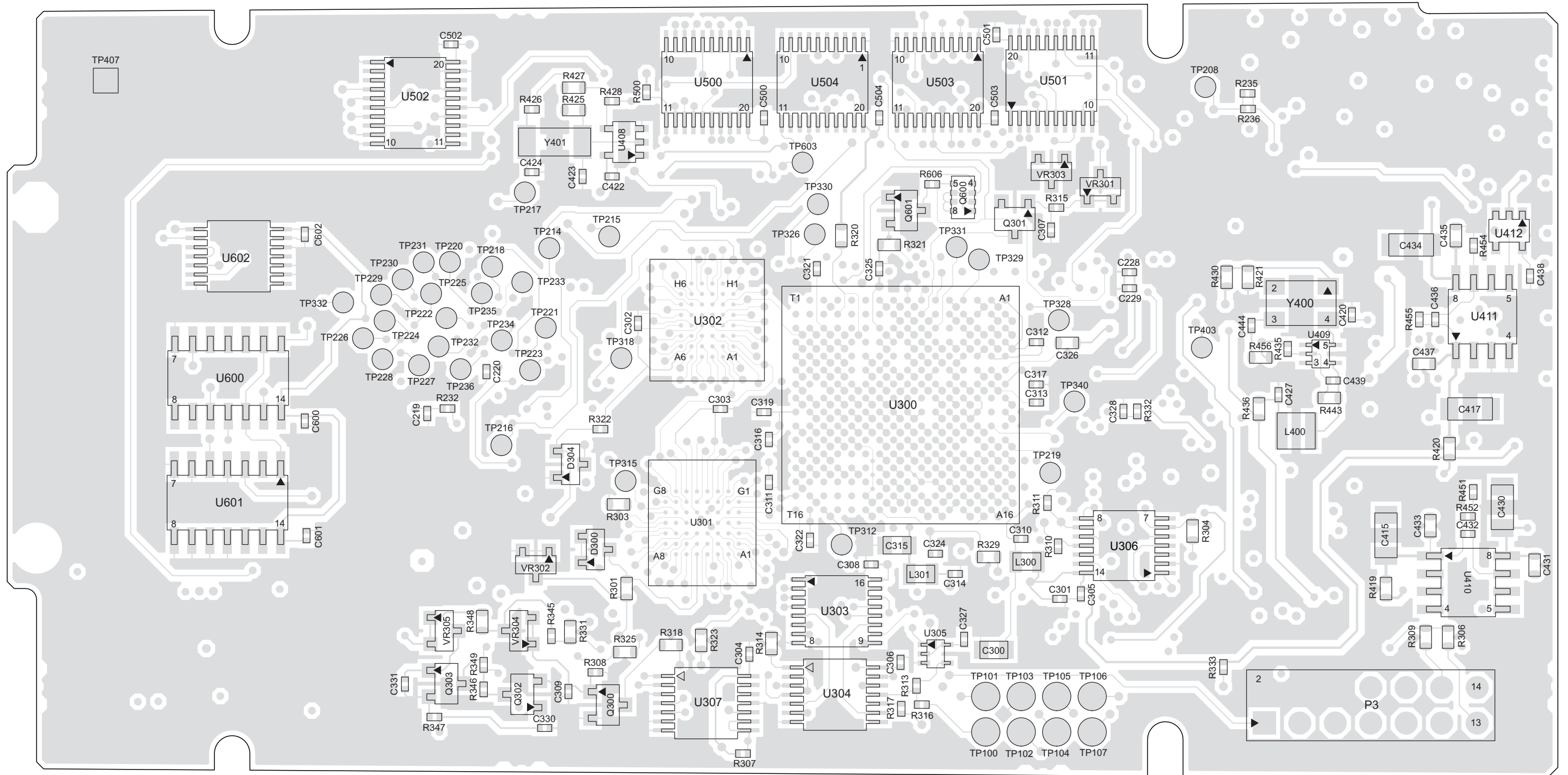

MAEPF-27511-O

HLN6837C ASTRO Spectra Plus VOCON Component Location Diagram, Top View

VIEWED FROM SIDE 2

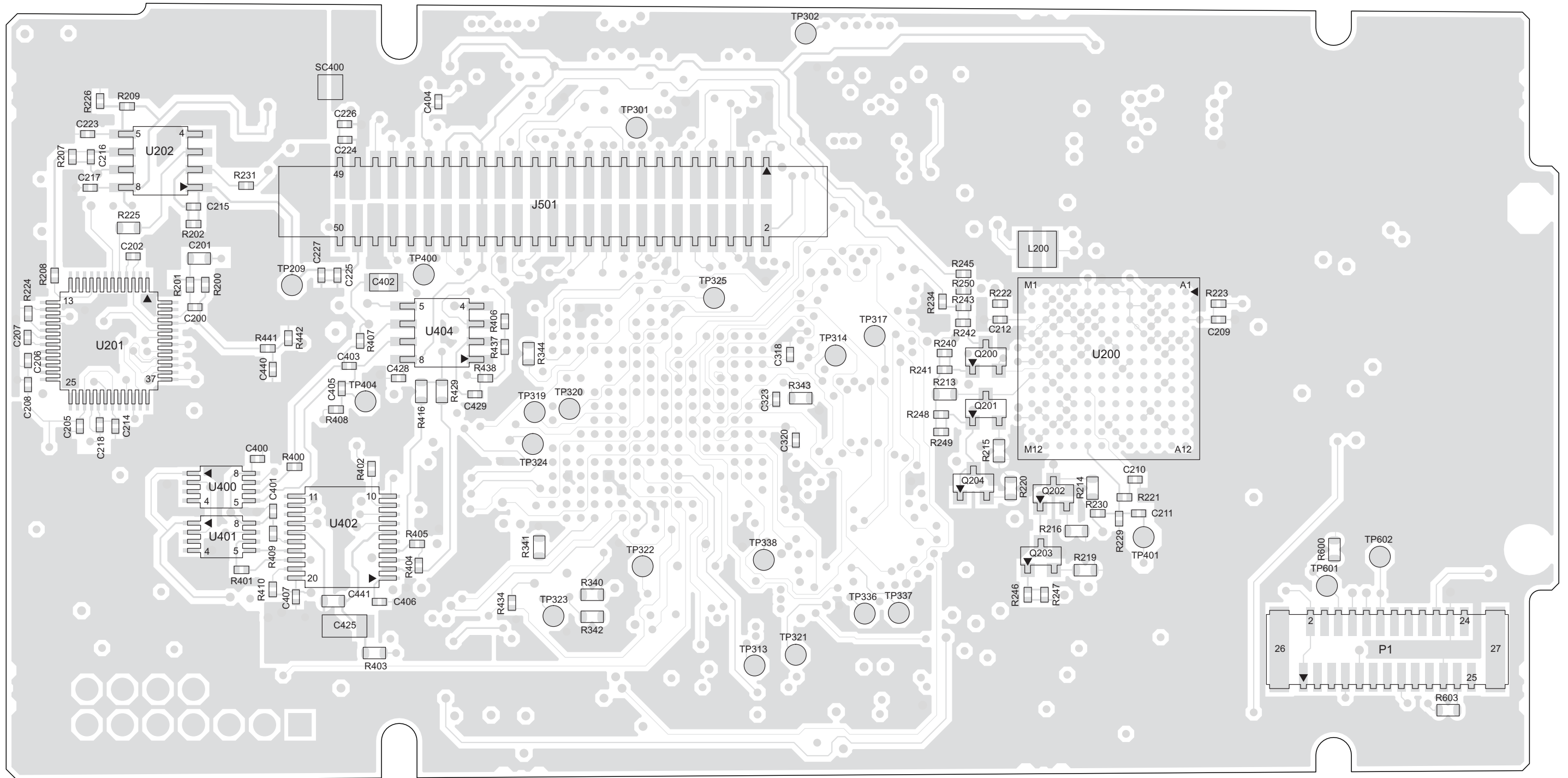

MAEPF-27512-O

HLN6837C ASTRO Spectra Plus VOCON Component Location Diagram, Bottom View

HLN6837C ASTRO Spectra Plus VOCON Electrical Parts List

ITEM	MOTOROLA PART NUMBER	DESCRIPTION
C200	2113743M24	CAP CHIP 100000 PF +80-20% Y5V
C201	2113740F18	CAP CHIP REEL CL1 +/-30 4.3
C202	2113743M24	CAP CHIP 100000 PF +80-20% Y5V
C205	2113743M24	CAP CHIP 100000 PF +80-20% Y5V
C206	2113743M24	CAP CHIP 100000 PF +80-20% Y5V
C207	2113743L17	CAP CHIP 1000 PF 10% X7R
C208	2113743M24	CAP CHIP 100000 PF +80-20% Y5V
C209	2113743M24	CAP CHIP 100000 PF +80-20% Y5V
C210	2113743N26	CAP CHIP 10.0 PF 5% COG
C211	2113743L41	CAP CHIP 10000 PF 10% X7R
C212	2113743M24	CAP CHIP 100000 PF +80-20% Y5V
C214	2113743M24	CAP CHIP 100000 PF +80-20% Y5V
C215	2113743L33	CAP CHIP 4700 PF 10% X7R
C216	2113743L09	CAP CHIP 470 PF 10% X7R
C217	2113743M24	CAP CHIP 100000 PF +80-20% Y5V
C218	2113743M24	CAP CHIP 100000 PF +80-20% Y5V
C219	2113743M24	CAP CHIP 100000 PF +80-20% Y5V
C220	2113743M24	CAP CHIP 100000 PF +80-20% Y5V
C223	2113743M24	CAP CHIP 100000 PF +80-20% Y5V
C224	2113743L09	CAP CHIP 470 PF 10% X7R
C225	2113743L09	CAP CHIP 470 PF 10% X7R
C226	-----	NOTPLACED
C227	-----	NOTPLACED
C228	2113743L09	CAP CHIP 470 PF 10% X7R
C229	-----	NOTPLACED
C300	2113928E01	CAP CER CHIP 1.0 UF 10 % 10V
C301	2113743N38	CAP CHIP 33.0 PF 5% COG
C302	2113743M24	CAP CHIP 100000 PF +80-20% Y5V
C303	2113743M24	CAP CHIP 100000 PF +80-20% Y5V

ITEM	MOTOROLA PART NUMBER	DESCRIPTION
C304	2113743M24	CAP CHIP 100000 PF +80-20% Y5V
C305	2113743M24	CAP CHIP 100000 PF +80-20% Y5V
C306	2113743M24	CAP CHIP 100000 PF +80-20% Y5V
C307	2113743M24	CAP CHIP 100000 PF +80-20% Y5V
C308	2113743M24	CAP CHIP 100000 PF +80-20% Y5V
C309	2113743L09	CAP CHIP 470 PF 10% X7R
C310	2113743M24	CAP CHIP 100000 PF +80-20% Y5V
C311	2113743M24	CAP CHIP 100000 PF +80-20% Y5V
C312	2113743M24	CAP CHIP 100000 PF +80-20% Y5V
C313	2113743M24	CAP CHIP 100000 PF +80-20% Y5V
C314	2113743N38	CAP CHIP 33.0 PF 5% COG
C315	2113928E01	CAP CER CHIP 1.0 UF 10 % 10V
C316	2113743M24	CAP CHIP 100000 PF +80-20% Y5V
C317	2113743M24	CAP CHIP 100000 PF +80-20% Y5V
C318	2113743M24	CAP CHIP 100000 PF +80-20% Y5V
C319	2113743M24	CAP CHIP 100000 PF +80-20% Y5V
C320	2113743M24	CAP CHIP 100000 PF +80-20% Y5V
C321	2113743M24	CAP CHIP 100000 PF +80-20% Y5V
C322	2113743M24	CAP CHIP 100000 PF +80-20% Y5V
C323	2113743M24	CAP CHIP 100000 PF +80-20% Y5V
C324	2113743M24	CAP CHIP 100000 PF +80-20% Y5V
C325	2113743M24	CAP CHIP 100000 PF +80-20% Y5V
C326	2113740F59	CAP CHIP REEL CL1 +/-30 220
C327	2113743M24	CAP CHIP 100000 PF +80-20% Y5V
C328	2113743M24	CAP CHIP 100000 PF +80-20% Y5V
C330	2113743L09	CAP CHIP 470 PF 10% X7R
C331	2113743L09	CAP CHIP 470 PF 10% X7R

ITEM	MOTOROLA PART NUMBER	DESCRIPTION
C400	2113743M24	CAP CHIP 100000 PF +80-20% Y5V
C401	2113743M24	CAP CHIP 100000 PF +80-20% Y5V
C402	2113928E01	CAP CER CHIP 1.0 UF 10 % 10V
C403	2113743N54	CAP CHIP 150 PF 5% COG
C404	2113743N38	CAP CHIP 33.0 PF 5% COG
C405	2113743M24	CAP CHIP 100000 PF +80-20% Y5V
C406	2113743M24	CAP CHIP 100000 PF +80-20% Y5V
C407	2113743L41	CAP CHIP 10000 PF 10% X7R
C415	2185802B01	CAP 10V 4.7UF
C417	2185802B01	CAP 10V 4.7UF
C420	2113743M24	CAP CHIP 100000 PF +80-20% Y5V
C422	2113743M24	CAP CHIP 100000 PF +80-20% Y5V
C423	2113743N28	CAP CHIP 12.0 PF 5% COG
C424	2113743N28	CAP CHIP 12.0 PF 5% COG
C425	2185802B01	CAP 10V 4.7UF
C427	2113743N50	CAP CHIP 100 PF 5% COG
C428	2113743M24	CAP CHIP 100000 PF +80-20% Y5V
C429	2113743N54	CAP CHIP 150 PF 5% COG
C430	2185802B01	CAP 10V 4.7UF
C431	2113743E20	CAP CHIP .10 UF 10%
C432	2113743L41	CAP CHIP 10000 PF 10% X7R
C433	2113743E20	CAP CHIP .10 UF 10%
C434	2185802B01	CAP 10V 4.7UF
C435	2113743E20	CAP CHIP .10 UF 10%
C436	2113743L41	CAP CHIP 10000 PF 10% X7R
C437	2113743E20	CAP CHIP .10 UF 10%
C438	2113743L41	CAP CHIP 10000 PF 10% X7R
C439	2113743N30	CAP CHIP 15.0 PF 5% COG
C440	-----	NOTPLACED
C441	2113743E20	CAP CHIP .10 UF 10%
C444	2113743N50	CAP CHIP 100 PF 5% COG
C500	2113743M24	CAP CHIP 100000 PF +80-20% Y5V
C501	2113743M24	CAP CHIP 100000 PF +80-20% Y5V
C502	2113743M24	CAP CHIP 100000 PF +80-20% Y5V
C503	2113743M24	CAP CHIP 100000 PF +80-20% Y5V

ITEM	MOTOROLA PART NUMBER	DESCRIPTION
C504	2113743M24	CAP CHIP 100000 PF +80-20% Y5V
C600	2113743M24	CAP CHIP 100000 PF +80-20% Y5V
C601	2113743M24	CAP CHIP 100000 PF +80-20% Y5V
C602	2113743M24	CAP CHIP 100000 PF +80-20% Y5V
D300	4805129M90	DIODE SOT PKGD
D304	4805129M90	DIODE SOT PKGD
J501	0905516W02	CONN RECEPTACLE
L200	2462587N58	CHIP IND 270 NH 5%
L300	2480067M02	CHK RF CHIP BEAD INDUCTOR
L301	2480067M02	CHK RF CHIP BEAD INDUCTOR
L400	2462587N68	CHIP IND 1000 NH 5%
P1	0913915A11	RECP SMT LOPRO 25 POS
P3	-----	NOTPLACED
PCB	8485146D03	PCB ASTRO SPECTRA PLUS VOCON
Q200	4813824A10	TSTR NPN 40V .2A GEN PURP
Q201	4805128M12	TSTR SOT BCW 60B (RH)
Q202	4805128M12	TSTR SOT BCW 60B (RH)
Q203	4805128M12	TSTR SOT BCW 60B (RH)
Q204	4805128M12	TSTR SOT BCW 60B (RH)
Q300	4880048M01	TSTR NPN DIG 47K/47K
Q301	4880048M01	TSTR NPN DIG 47K/47K
Q302	4880048M01	TSTR NPN DIG 47K/47K
Q303	4880048M01	TSTR NPN DIG 47K/47K
Q600	4885844C02	XSTR P-CH MOSFET 30V 80MOHM@4.5V
Q601	4880048M01	TSTR NPN DIG 47K/47K
R200	0662057N23	RES. CHIP 100K 5% 20X40
R201	0662057N23	RES. CHIP 100K 5% 20X40
R202	0662057M81	RES. CHIP 2000 5% 20X40
R207	0662057N05	RES. CHIP 18K 5% 20X40
R208	0662057N10	RES. CHIP 30K 5% 20X40
R209	0662057N10	RES. CHIP 30K 5% 20X40
R213	0662057A35	CHIP RES 270 OHMS 5%
R214	0662057A35	CHIP RES 270 OHMS 5%
R215	0662057A13	CHIP RES 33 OHMS 5%
R216	0662057A13	CHIP RES 33 OHMS 5%
R219	0662057A37	CHIP RES 330 OHMS 5%
R220	0662057A37	CHIP RES 330 OHMS 5%
R221	0662057N05	RES. CHIP 18K 5% 20X40
R222	0662057N23	RES. CHIP 100K 5% 20X40

ITEM	MOTOROLA PART NUMBER	DESCRIPTION
R223	0662057M98	RES. CHIP 10K 5% 20X40
R224	0662057N23	RES. CHIP 100K 5% 20X40
R225	0662057B47	CHIP RES 0 OHMS +/-0.050 OHMS
R226	0662057N10	RES. CHIP 30K 5% 20X40
R229	0662057N23	RES. CHIP 100K 5% 20X40
R230	0662057N23	RES. CHIP 100K 5% 20X40
R231	0662057N10	RES. CHIP 30K 5% 20X40
R232	0662057M98	RES. CHIP 10K 5% 20X40
R234	0662057M50	RES. CHIP 100 5% 20X40
R235	0662057M34	RES. CHIP 22 5% 20X40
R236	0662057M34	RES. CHIP 22 5% 20X40
R240	0662057M86	RES. CHIP 3300 5X 20X40
R241	-----	NOTPLACED
R242	0662057M64	RES. CHIP 390 5% 20X40
R243	-----	NOTPLACED
R245	-----	NOTPLACED
R246	0662057M92	RES. CHIP 5600 5% 20X40
R247	-----	NOTPLACED
R248	0662057M92	RES. CHIP 5600 5% 20X40
R249	-----	NOTPLACED
R250	0662057M90	RES. CHIP 4700 5% 20X40
R301	0662057B47	CHIP RES 0 OHMS +/-0.050 OHMS
R303	0662057B47	CHIP RES 0 OHMS +/-0.050 OHMS
R304	0662057B47	CHIP RES 0 OHMS +/-0.050 OHMS
R306	-----	NOTPLACED
R307	0662057N15	RES. CHIP 47K 5% 20X40
R308	0662057N15	RES. CHIP 47K 5% 20X40
R309	-----	NOTPLACED
R310	0662057N15	RES. CHIP 47K 5% 20X40
R311	0662057M98	RES. CHIP 10K 5% 20X40
R313	0662057M78	RES. CHIP 1500 5% 20X40
R314	0662057B47	CHIP RES 0 OHMS +/-0.050 OHMS
R315	0662057N15	RES. CHIP 47K 5% 20X40
R316	0662057M34	RES. CHIP 22 5% 20X40
R317	0662057M34	RES. CHIP 22 5% 20X40
R318	0662057B47	CHIP RES 0 OHMS +/-0.050 OHMS
R320	-----	NOTPLACED
R321	-----	NOTPLACED
R322	0662057N23	RES. CHIP 100K 5% 20X40

ITEM	MOTOROLA PART NUMBER	DESCRIPTION
R323	0662057B47	CHIP RES 0 OHMS +/-0.050 OHMS
R325	0662057B47	CHIP RES 0 OHMS +/-0.050 OHMS
R329	0662057B47	CHIP RES 0 OHMS +/-0.050 OHMS
R331	0662057B47	CHIP RES 0 OHMS +/-0.050 OHMS
R332	0662057M98	RES. CHIP 10K 5% 20X40
R333	0662057N15	RES. CHIP 47K 5% 20X40
R340	0662057B47	CHIP RES 0 OHMS +/-0.050 OHMS
R341	-----	NOTPLACED
R342	-----	NOTPLACED
R343	0662057B47	CHIP RES 0 OHMS +/-0.050 OHMS
R344	0662057B47	CHIP RES 0 OHMS +/-0.050 OHMS
R345	0662057M74	RES. CHIP 1000 5% 20X40
R346	0662057N15	RES. CHIP 47K 5% 20X40
R347	0662057N15	RES. CHIP 47K 5% 20X40
R348	-----	NOTPLACED
R349	0662057N15	RES. CHIP 47K 5% 20X40
R400	0662057M86	RES. CHIP 3300 5X 20X40
R401	0662057M86	RES. CHIP 3300 5X 20X40
R402	0662057N23	RES. CHIP 100K 5% 20X40
R403	0662057B47	CHIP RES 0 OHMS +/-0.050 OHMS
R404	0662057M91	RES CHIP 5100 5% 20X40
R405	0662057M82	RES. CHIP 2200 5% 20X40
R406	0662057N23	RES. CHIP 100K 5% 20X40
R407	0662057M98	RES. CHIP 10K 5% 20X40
R408	0662057N05	RES. CHIP 18K 5% 20X40
R409	0662057N23	RES. CHIP 100K 5% 20X40
R410	0662057M98	RES. CHIP 10K 5% 20X40
R416	0662057B47	CHIP RES 0 OHMS +/-0.050 OHMS
R419	0662057B47	CHIP RES 0 OHMS +/-0.050 OHMS
R420	0662057B47	CHIP RES 0 OHMS +/-0.050 OHMS
R421	-----	NOTPLACED
R425	0662057B46	CHIP RES 10.0 MEG OHMS 5%
R426	0662057N39	RES. CHIP 470K 5% 20X40
R427	0662057B46	CHIP RES 10.0 MEG OHMS 5%
R428	0662057M50	RES. CHIP 100 5% 20X40

ITEM	MOTOROLA PART NUMBER	DESCRIPTION
R429	-----	NOTPLACED
R430	0662057B47	CHIP RES 0 OHMS +/-0.050 OHMS
R434	0662057M81	RES. CHIP 2000 5% 20X40
R435	0662057M74	RES. CHIP 1000 5% 20X40
R436	0662057B47	CHIP RES 0 OHMS +/-0.050 OHMS
R437	0662057N07	RES. CHIP 22K 5% 20X40
R438	0662057N07	RES. CHIP 22K 5% 20X40
R441	0662057N39	RES. CHIP 470K 5% 20X40
R442	0662057N39	RES. CHIP 470K 5% 20X40
R443	0662057B46	CHIP RES 10.0 MEG OHMS 5%
R451	0662057N13	RES. CHIP 39K 5% 20X40
R452	0662057N06	RES. CHIP 20K 5% 20X40
R454	0662057N11	RES. CHIP 33K 5% 20X40
R455	0662057N15	RES. CHIP 47K 5% 20X40
R456	0662057B47	CHIP RES 0 OHMS +/-0.050 OHMS
R500	0662057M81	RES. CHIP 2000 5% 20X40
R600	0662057B47	CHIP RES 0 OHMS +/-0.050 OHMS
R603	0662057B47	CHIP RES 0 OHMS +/-0.050 OHMS
R606	0662057N23	RES. CHIP 100K 5% 20X40
U200	5185963A50	IC CMOS KRSIC
U201	5105457W85	CC ADDAG IC
U202	5113818A14	IC DL OP AMP RAIL TO RAIL
U300	5109841C69	IC 256 BGA 17X17 PACKAGE PATRIOT
U301	5185368C95	IC BURST FLASH 32MB
U302	5185130C38	IC SRAM 4MG
U303	5105109Z31	IC QUAD 2:1 MUX/DEMUX
U304	5185368C53	IC USB TRANSCEIVER 14 PIN TSSOP14
U305	5109522E53	IC SNGL BUF NC7S125P5X SC70
U306	5113837A15	IC 3.3V QUAD BUFFER
U307	5113837A02	IC NOR QUAD 2 IN MC 74LCX02DTR
U400	5185368C55	ICDIGITAL EEPOT 8 PIN S08
U401	5185368C55	ICDIGITAL EEPOT 8 PIN S08
U402	5105109Z38	3 VOLT LINEAR PCM CODEC FILTER
U404	5113818A14	IC DL OP AMP RAIL TO RAIL
U408	5185623B01	HIGH SPEED CMOS INVERTER

ITEM	MOTOROLA PART NUMBER	DESCRIPTION
U409	5185353D93	IC AHCMOS SINGER GATE BUFFERED INVERTER
U410	5185353D55	IC VOLTAGE REGULATOR 100MZ ADJ
U411	5185353D55	IC VOLTAGE REGULATOR 100MZ ADJ
U412	5185353D46	IF 4.3V VOLTAGE DETECTOR
U500	5113805C01	IC LN DRVR/RCVR 3V
U501	5113805C01	IC LN DRVR/RCVR 3V
U502	5113805C01	IC LN DRVR/RCVR 3V
U503	5113837A07	IC LINE DRVR OCT3 MC74LCX244DT
U504	5113837A07	IC LINE DRVR OCT3 MC74LCX244DT
U600	5113805B16	IC CNTR DL 4 STAGE BIN HC393D
U601	5113806A05	IC FLIP-FLOP,DUAL D
U602	5113805B44	IC OR QUAD 2-IN
VR301	4813830A11	DIODE 3.9V 5% 225MW MMBZ5228B_
VR302	4813830A28	DIODE 15V 5% 225MW MMBZ5245B_
VR303	4813830A15	DIODE 5.6V 5% 225MW MMBZ5232B_
VR304	4813830A22	DIODE 9.1V 5% 225MW MMBZ5239B_
VR305	4813830A15	DIODE 5.6V 5% 225MW MMBZ5232B_
Y400	4885071E01	MODULE REFERENCE OSCILLATOR 16.8 MHZ 5X3.2 MM
Y401	4809995L05	XTAL QUARTZ 32.768KHZ CC4V-T1

Notes

7.6 VCO Section

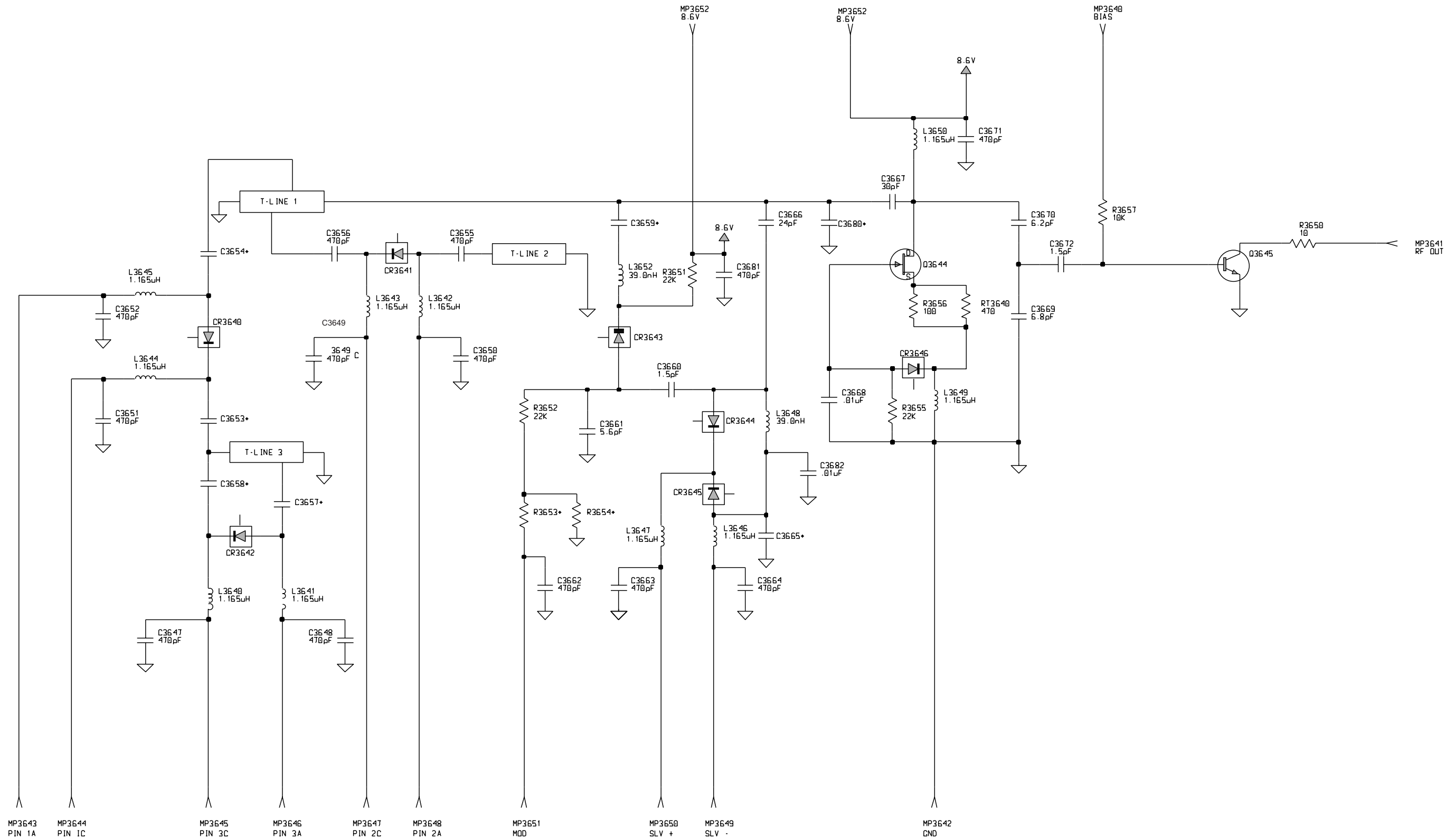

HLD6061D and HLD6062D VHF VCO Hybrid Schematic

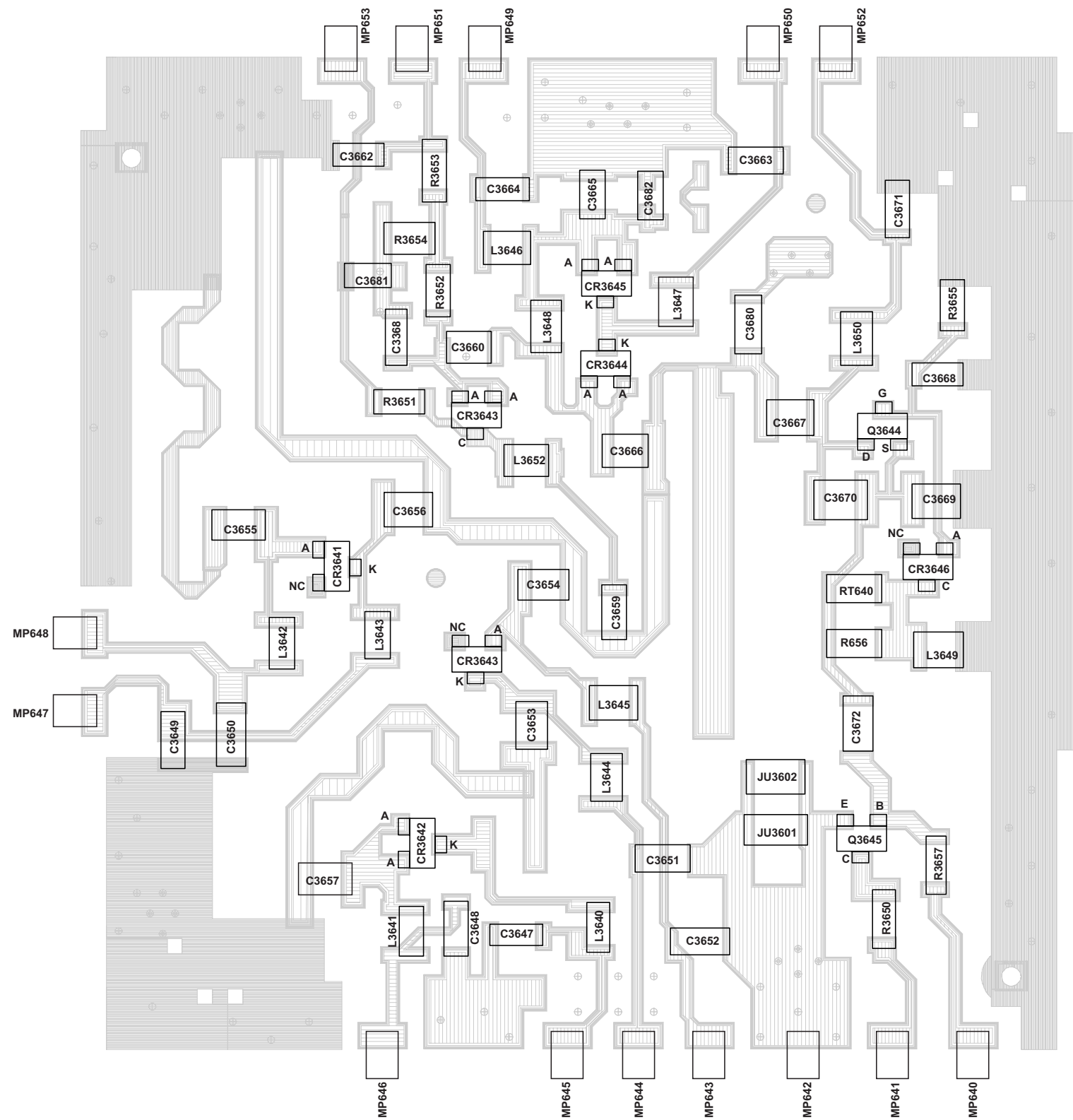

HLD6061D and HLD6062D VHF VCO Hybrid Component Location Diagram

HLD6061D and HLD6062D Parts List

ITEM	MOTOROLA PART NUMBER	DESCRIPTION
C3647 thru C3652	2113740B65	CAP CHIP REEL CL1 +/-30 470
C3653	2113740B73 2113740B65	CAP CHIP REEL CL1 +/-30 1000 ¹ CAP CHIP REEL CL1 +/-30 470 ²
C3654	2113740B69 2111078B59	CAP CHIP REEL CL1 +/-30 680 ¹ CAP CHIP RF 470 5 NPO 100V ²
C3655 & C3656	2111078B59	CAP CHIP RF 470 5 NPO 100V
C3657	2111078B59 2113740B65	CAP CHIP RF 470 5 NPO 100V ¹ CAP CHIP REEL CL1 +/-30 470 ²
C3658	2111078B59 2113740B65	CAP CHIP RF 470 5 NPO 100V ¹ CAP CHIP REEL CL1 +/-30 470 ²
C3659	2113740B11 2113740B09	CAP CHIP REEL CL1 +/-30 2.7 ¹ CAP CHIP REEL CL1 +/-30 2.2 ²
C3660	2113740B11	CAP CHIP REEL CL1 +/-30 2.7
C3661	2113740B19	CAP CHIP REEL CL1 +/-30 5.6
C3662 & C3663	2113740B65	CAP CHIP REEL CL1 +/-30 470
C3664	2113741N45	CAP CHIP CL2 X7R 10% 10000
C3665	2111078B59 2111078B31	CAP CHIP RF 470 5 NPO 100V ¹ CAP CHIP RF 36 5 NPO 100V ²
C3666	2111078B23	CAP CHIP RF 24 5 NPO 100V
C3667	2111078B31	CAP CHIP RF 36 5 NPO 100V
C3668	2113741N45	CAP CHIP CL2 X7R 10% 10000
C3669	2111078B05	CAP CHIP RF 4.7 .25 NPO 100V
C3670	2111078B11	CAP CHIP RF 8.2 .5 NPO 100V
C3671	2113740B65	CAP CHIP REEL CL1 +/-30 470
C3672	2113740B05	CAP CHIP REEL CL1 +/-30 1.5

ITEM	MOTOROLA PART NUMBER	DESCRIPTION
C3680	2113740B01 -----	CAP CHIP REEL CL1 +/-30 1.0 ¹ NOTPLACED ²
C3681	2113740B65	CAP CHIP REEL CL1 +/-30 470
C3682	2113741N45	CAP CHIP CL2 X7R 10% 10000
CR3640	4805656W04	DIODE SOT 23 PIN
CR3641 & CR3642	4880142L01	DIODE PIN SOT 23 MMBV 3401
CR3643	4880006E09	DIODE VARACTOR MMBV109 350MW
CR3644 & CR3645	4880006E13	DIODE VAR SI SMBV1050 350MW
CR3646	4813825A05	DIODE 30V HOT CARRIER MMBD301L
JU3601	----- 0611077A01	NOTPLACED ¹ RES CHIP JUMPER ²
JU3602	0611077A01 -----	RES CHIP JUMPER ¹ NOTPLACED ²
L3640 thru L3647	2480140E01	INDUCTOR CHIP 1.2 UH
L3648	2405452C87	COIL CHIP INDUCTOR 39 5
L3649 & L3650	2480140E01	INDUCTOR CHIP 1.2 UH
L3652	2405452C87	COIL CHIP INDUCTOR 39 5
MP3640 thru MP3653	0780299L01	FRAME LEAD J STRAP
Q3644	4880141L06	TSTR NC MOS FET SOT23 TGR MMBF
Q3645	4813827A03	TSTR NPN SML SIG MMBR901LT1 7X
R3650	0611077A26	RES CHIP 10 5 1/8W
R3651 & R3652	0611077B07	RES CHIP 22K 5 1/8W
R3653	0611077B03	RES CHIP 15K 5 1/8W
R3654	0611077B23 -----	RES CHIP 100K 5 1/8W ¹ NOTPLACED ²
R3655	0611077B07	RES CHIP 22K 5 1/8W
R3656	0611077A50	RES CHIP 100 5 1/8W
R3657	0611077A66	RES CHIP 470 5 1/8W
RT3640	0680149M01	THERMISTOR CHIP 470 OHMS
	1280954T43	SPECTRA VHF VCO ASSEMBLY

Notes:

1. Valid in HLD6061D only.
2. Valid in HLD6062D only.

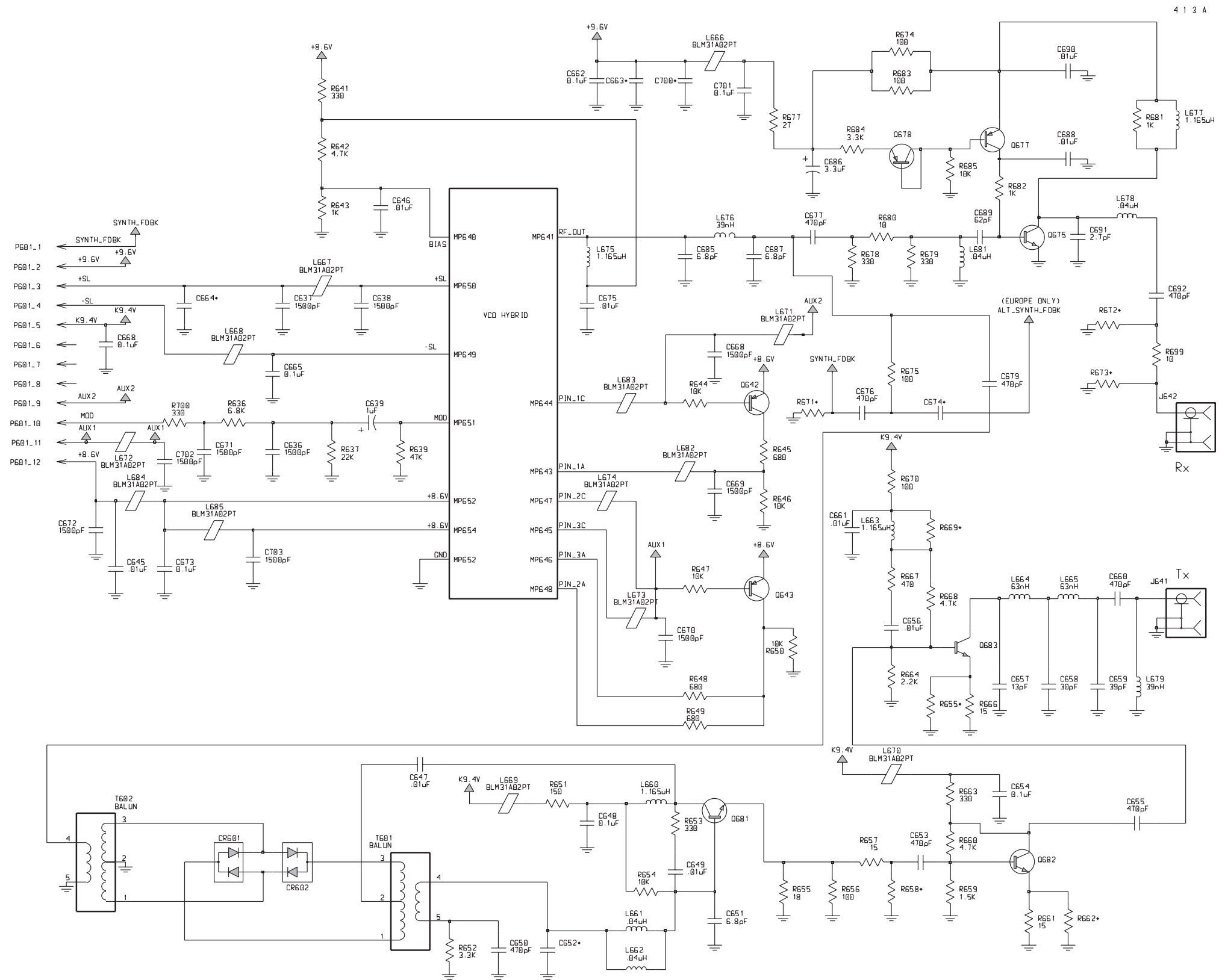

HLD4342B and HLD4343B VHF VCO Carrier Schematic Diagram

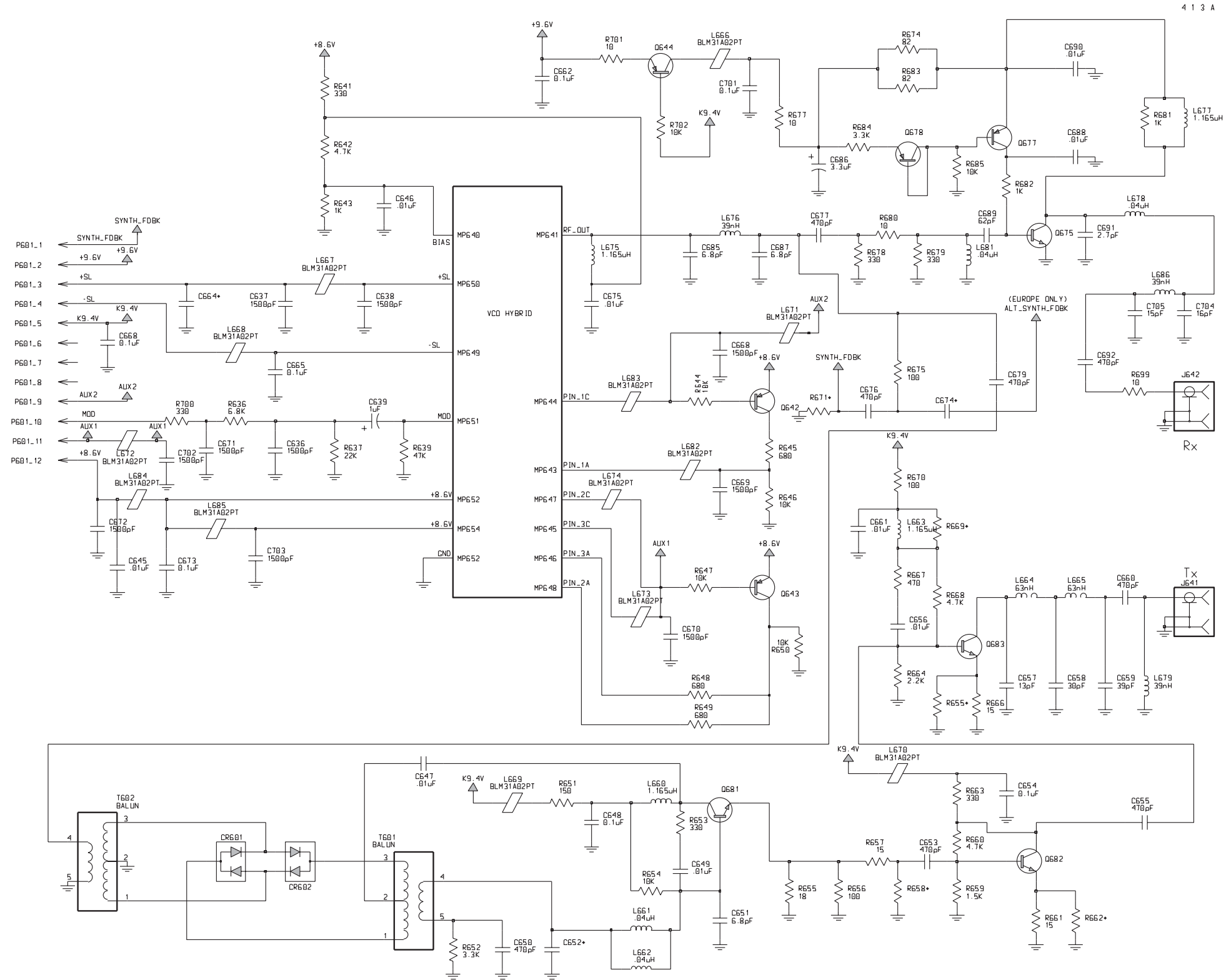

HLD4342D and HLD4343D VHF VCO Carrier Schematic Diagram

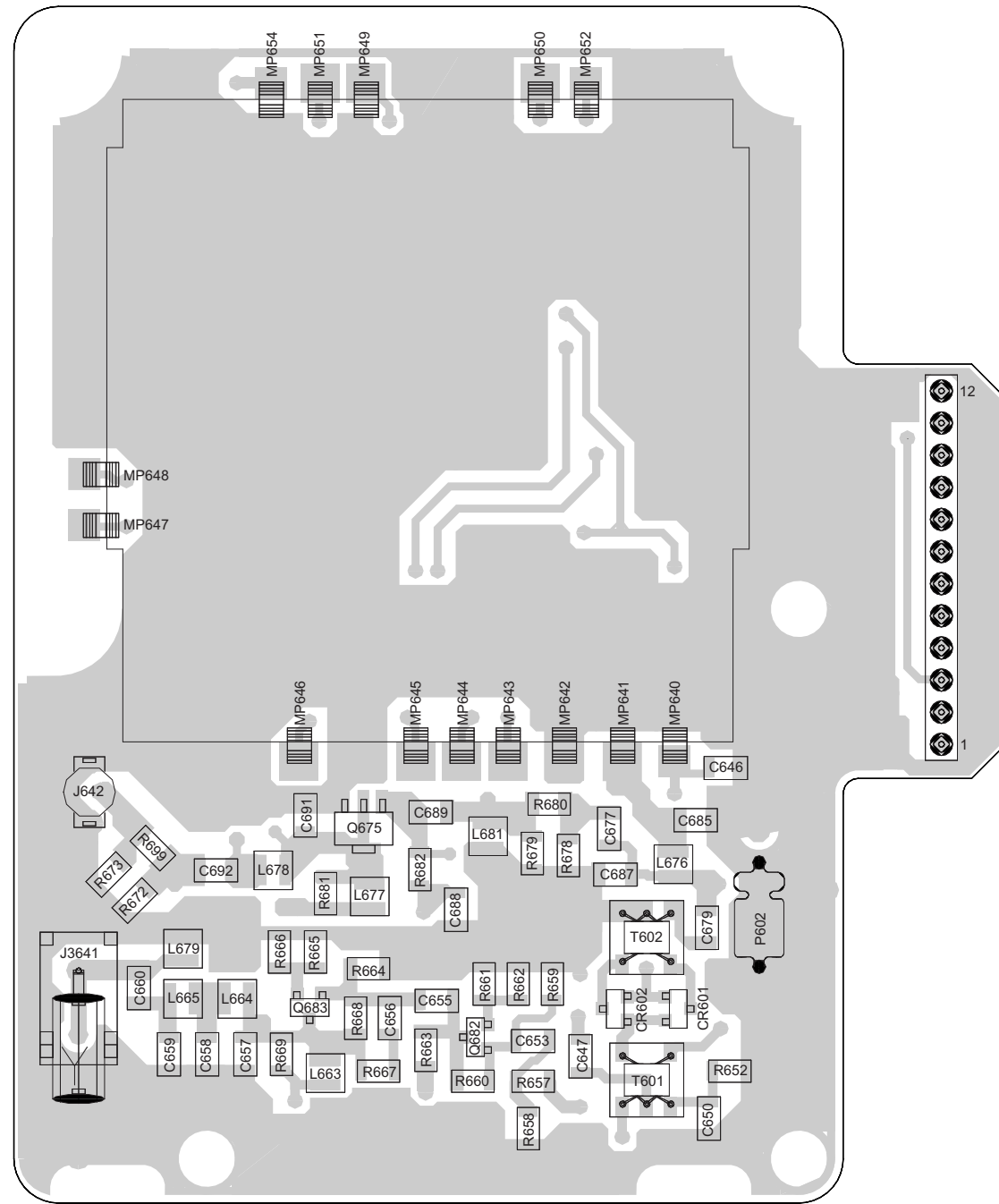

Side 1

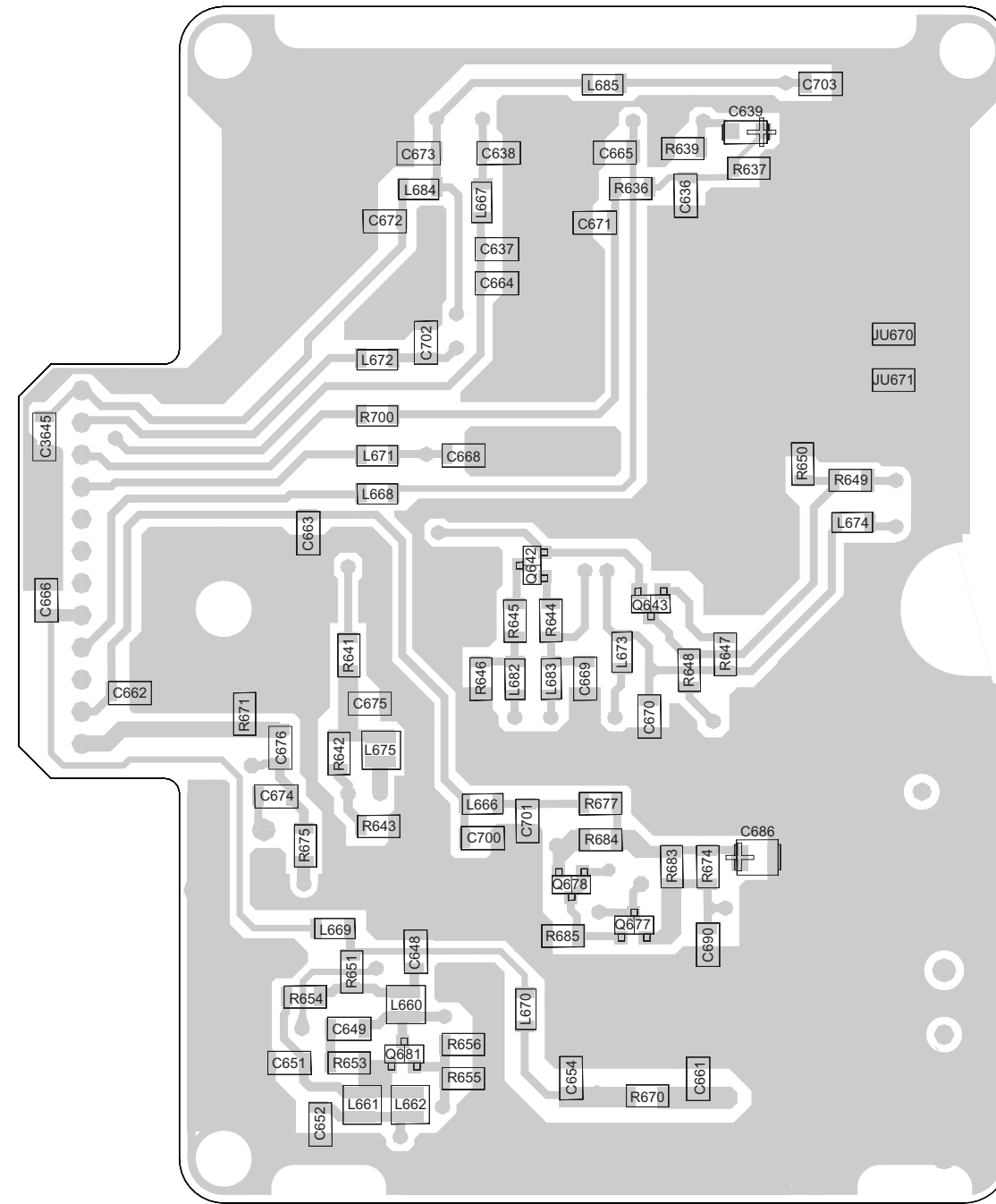

Side 2

HLD4342B/HLD4343B VHF VCO Carrier Component Location Diagram

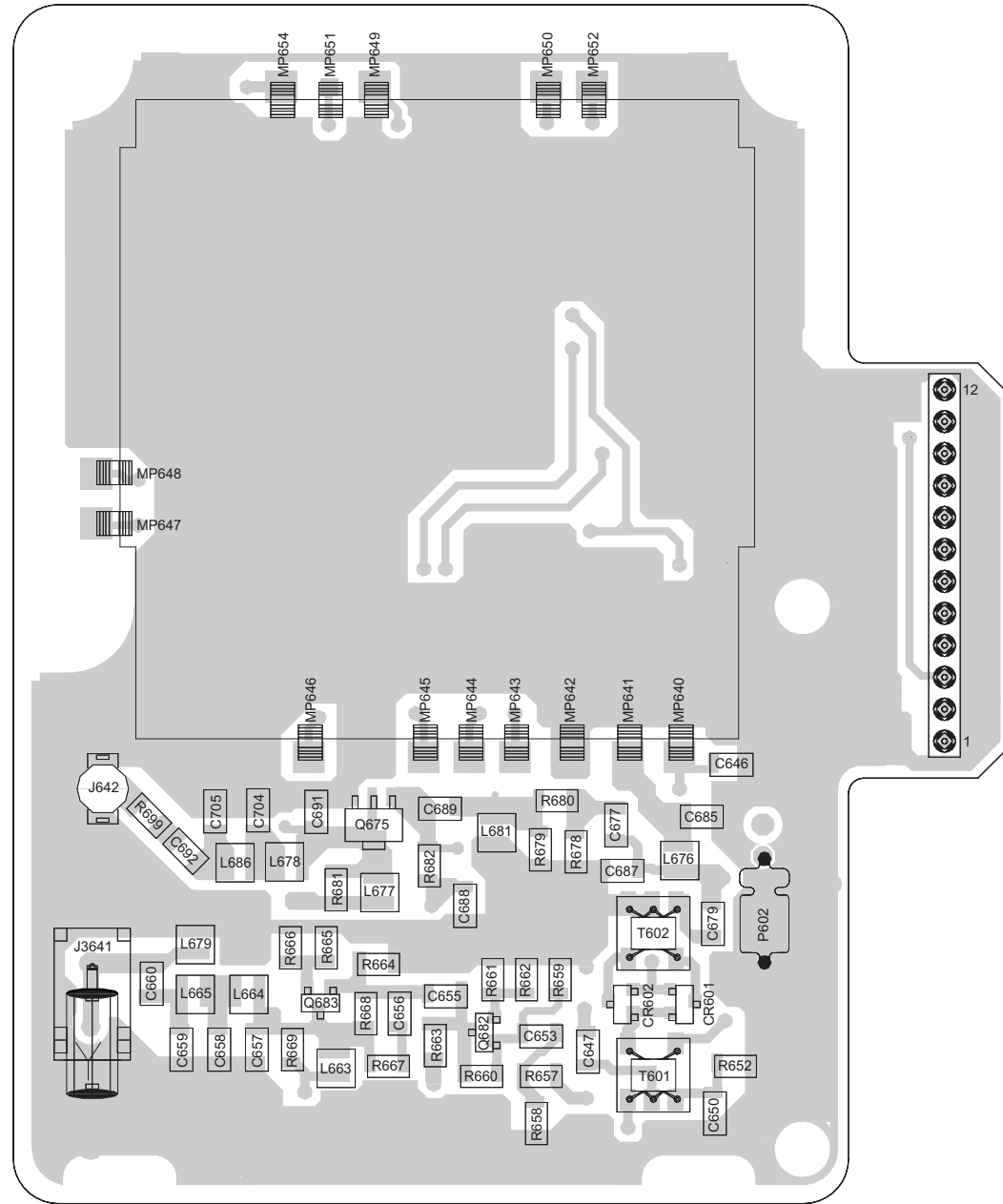

Side 1

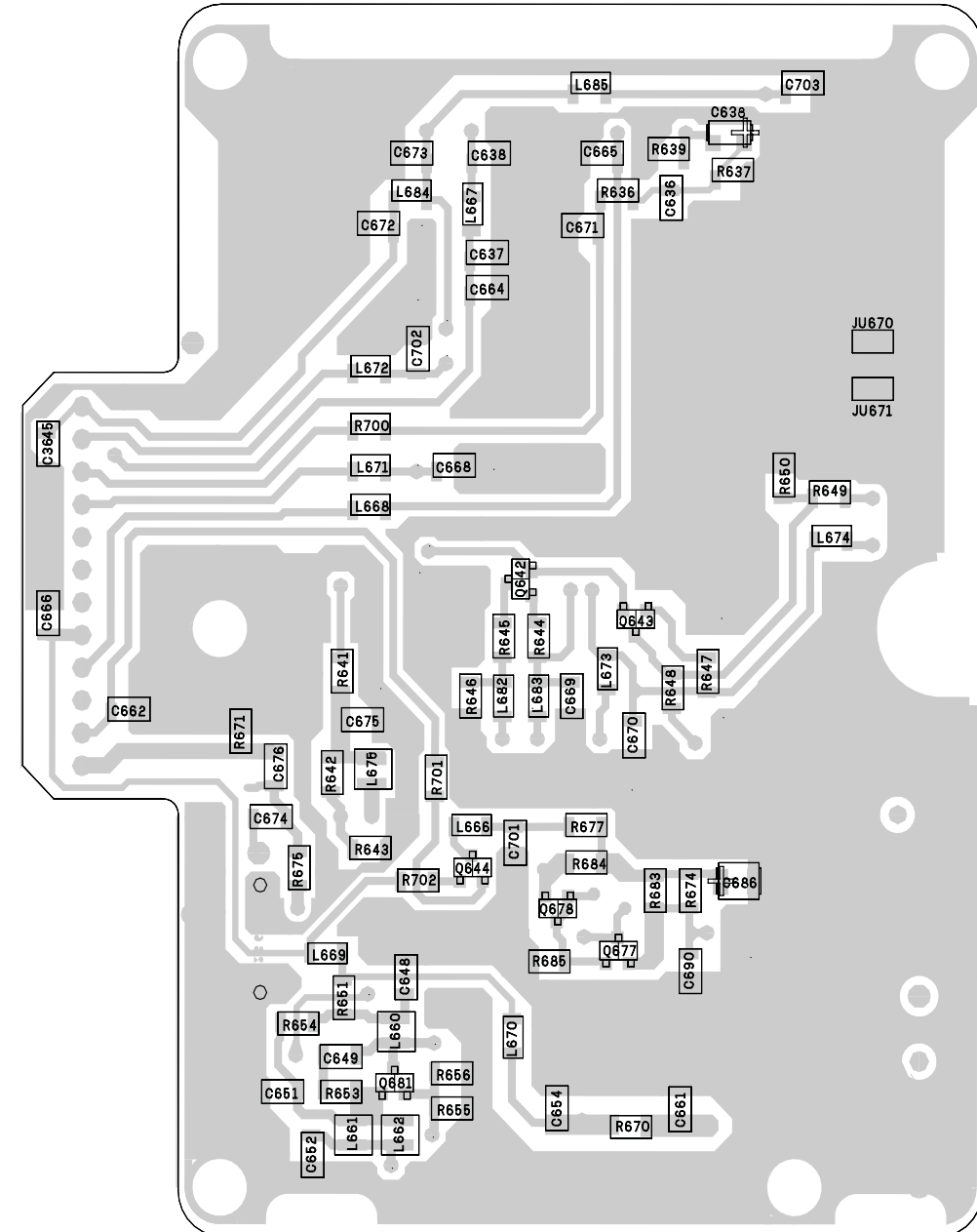

Side 2

HLD4342D/HLD4343D VHF VCO Carrier Component Location Diagram

HLD4342B and HLD4343B VHF VCO Parts List

ITEM	MOTOROLA PART NUMBER	DESCRIPTION
C3645	2113741N45	CAP CHIP CL2 X7R 10% 10000
C3655	2113740B65	CAP CHIP REEL CL1 +/-30 470
C3656	2113741N45	CAP CHIP CL2 X7R 10% 10000
C3657	2113740B28	CAP CHIP REEL CL1 +/-30 13
C3658	2113740B36	CAP CHIP REEL CL1 +/-30 30
C3659	2113740B39	CAP CHIP REEL CL1 +/-30 39
C3660	2113740B65	CAP CHIP REEL CL1 +/-30 470
C636	2113741N21	CAP CHIP CL2 X7R 10% 1000
C637 & C638	2113740B76	CAP CHIP REEL CL1 +/-30 1500
C639	2311049A37	CAP TANT CHIP 1 20 20
C646 & C647	2113741N45	CAP CHIP CL2 X7R 10% 10000
C648	2113741N69	CAP CHIP CL2 X7R 10% 100000
C649	2113741N45	CAP CHIP CL2 X7R 10% 10000
C650	2113740B65	CAP CHIP REEL CL1 +/-30 470
C651	2113740B21	CAP CHIP REEL CL1 +/-30 6.8
C652	-----	NOTPLACED
C653	2113740B65	CAP CHIP REEL CL1 +/-30 470
C654	2160521H41	CAP CHIP 220K 80 20 25V Y5V
C661	2113741N45	CAP CHIP CL2 X7R 10% 10000
C662	2113741N69	CAP CHIP CL2 X7R 10% 100000
C663 & C664	-----	NOTPLACED
C665	2113741N69	CAP CHIP CL2 X7R 10% 100000
C666	2160521H41	CAP CHIP 220K 80 20 25V Y5V
C668 thru C672	2113740B76	CAP CHIP REEL CL1 +/-30 1500
C673	2113741N69	CAP CHIP CL2 X7R 10% 100000
C674	----- 2113740B65	NOTPLACED ¹ CAP CHIP REEL CL1 +/-30 470 ²
C675	2113741N45	CAP CHIP CL2 X7R 10% 10000
C676	2113740B65 -----	CAP CHIP REEL CL1 +/-30 470 ¹ NOTPLACED ²
C677 & C679	2113740B65	CAP CHIP REEL CL1 +/-30 470
C685	2113740B21	CAP CHIP REEL CL1 +/-30 6.8
C686	2311049J07	CAP TANT CHIP 3.3 10 20
C687	2113740B21	CAP CHIP REEL CL1 +/-30 6.8

ITEM	MOTOROLA PART NUMBER	DESCRIPTION
C688	2113741N45	CAP CHIP CL2 X7R 10% 10000
C689	2113740B44	CAP CHIP REEL CL1 +/-30 62
C690	2113741N45	CAP CHIP CL2 X7R 10% 10000
C691	2113740B11	CAP CHIP REEL CL1 +/-30 2.7
C692	2113740B65	CAP CHIP REEL CL1 +/-30 470
C700	-----	NOTPLACED
C701	2113741N69	CAP CHIP CL2 X7R 10% 100000
C702 & C703	2113740B76	CAP CHIP REEL CL1 +/-30 1500
CR601 & CR602	4880154K03	DIODE DUAL SCHOTTKY MIXER
J3641	0980110M01	RECP COAX PCB MOUNT
J642	0980212N03	RECP COAX PCB MOUNT
JU670 & JU671	-----	NOTPLACED
L3663	2480140E01	INDUCTOR CHIP 1.2 UH
L3664 & L3665	2480140E04	INDUCTOR CHIP 65 NH
L660	2480140E01	INDUCTOR CHIP 1.2 UH
L661 & L662	2480140E03	INDUCTOR CHIP 50 NH
L666 thru L674	2480067M01	CHK RF CHIP BEAD INDUCTOR 28MZ
L675	2480140E01	INDUCTOR CHIP 1.2 UH
L676	2405452C87	COIL CHIP INDUCTOR 39 5
L677	2480140E01	INDUCTOR CHIP 1.2 UH
L678	2480140E03	INDUCTOR CHIP 50 NH
L679	2405452C87	COIL CHIP INDUCTOR 39 5
L681	2480140E03	INDUCTOR CHIP 50 NH
L682 thru L685	2480067M01	CHK RF CHIP BEAD INDUCTOR 28MZ
P0601	2880099M02	PLUG VERTICAL
P0602	----- 4280088P01	NOTPLACED ¹ CLIP COAX ²
Q3683	4813827A03	TSTR NPN SML SIG MMBR901LT1 7X
Q642 & Q643	4880141L01	TSTR PNP SOT23 LO PROFILE TAPE
Q675	4802000P02	NEC SILICON TR 2SC3357 RE
Q677 & Q678	4880141L01	TSTR PNP SOT23 LO PROFILE TAPE
Q681	4813827A03	TSTR NPN SML SIG MMBR901LT1 7X
Q682	4813827A03	TSTR NPN SML SIG MMBR901LT1 7X
R3663	0611077A62	RES CHIP 330 5 1/8W
R3664	0611077A82	RES CHIP 2200 5 1/8
R3665	-----	NOTPLACED
R3666	0611077A30	RES CHIP 15 5 1/8W
R3667	0611077A66	RES CHIP 470 5 1/8W

ITEM	MOTOROLA PART NUMBER	DESCRIPTION
R3668	0611077A90	RES CHIP 4700 5 1/8
R3669	-----	NOTPLACED
R636	0611077A94	RES CHIP 6800 5 1/8
R637	0611077B07	RES CHIP 22K 5 1/8W
R639	0611077B15	RES CHIP 47K 5 1/8W
R641	0611077A58	RES CHIP 220 5 1/8W
R642	0611077A90	RES CHIP 4700 5 1/8
R643	0611077A74	RES CHIP 1000 5 1/8
R644	0611077A98	RES CHIP 10K 5 1/8W
R645	0611077A58	RES CHIP 220 5 1/8W
R646 & R647	0611077A98	RES CHIP 10K 5 1/8W
R648 & R649	0611077A70	RES CHIP 680 5 1/8W
R650	0611077A98	RES CHIP 10K 5 1/8W
R651	0611077A54	RES CHIP 150 5 1/8W
R652	0611077A86	RES CHIP 3300 5 1/8
R652	-----	NOTPLACED
R653	0611077A62	RES CHIP 330 5 1/8W
R654	0611077A98	RES CHIP 10K 5 1/8W
R655	0611077A32	RES CHIP 18 5 1/8W
R656	0611077A50	RES CHIP 100 5 1/8W
R657	0611077A30	RES CHIP 15 5 1/8W
R658	-----	NOTPLACED
R659	0611077A78	RES CHIP 1500 5 1/8
R660	0611077A90	RES CHIP 4700 5 1/8
R661	0611077A30	RES CHIP 15 5 1/8W
R662	-----	NOTPLACED
R670	0611077A50	RES CHIP 100 5 1/8W
R671	-----	NOTPLACED
R672	-----	NOTPLACED ¹
R673	----- 0611077A58	NOTPLACED ¹ RES CHIP 220 5 1/8W ² RES CHIP 220 5 1/8W ²
R674 & R675	0611077A50	RES CHIP 100 5 1/8W
R677	0611077A36	RES CHIP 27 5 1/8W
R678 & R679	0611077A62	RES CHIP 330 5 1/8W
R680	0611077A26	RES CHIP 10 5 1/8W
R681 & R682	0611077A74	RES CHIP 1000 5 1/8
R683	0611077A50	RES CHIP 100 5 1/8W
R684	0611077A86	RES CHIP 3300 5 1/8
R685	0611077A98	RES CHIP 10K 5 1/8W
R699	0611077A38	RES CHIP 33 5 1/8W
R700	0611077A62	RES CHIP 330 5 1/8W
T601 & T602	2405548Q06	TRANSFORMER, RF
	1280954T43	SPECTRA VHF VCO ASSEMBLY

Notes:

- Valid in HLD4342B
- Valid in HLD4343B

HLD4342D and HLD4343D VHF VCO Parts List

ITEM	MOTOROLA PART NUMBER	DESCRIPTION
C3645	2113741N45	CAP CHIP CL2 X7R 10% 10000
C3655	2113740B65	CAP CHIP REEL CL1 +/-30 470
C3656	2113741N45	CAP CHIP CL2 X7R 10% 10000
C3657	2113740B28	CAP CHIP REEL CL1 +/-30 13
C3658	2113740B36	CAP CHIP REEL CL1 +/-30 30
C3659	2113740B39	CAP CHIP REEL CL1 +/-30 39
C3660	2113740B65	CAP CHIP REEL CL1 +/-30 470
C636	2113740B76	CAP CHIP REEL CL1 +/-30 1500 ¹
C637 & C638	2113740B76	CAP CHIP REEL CL1 +/-30 1500
C639	2311049A37	CAP TANT CHIP 1 20 20
C646 & C647	2113741N45	CAP CHIP CL2 X7R 10% 10000
C648	2113741N69	CAP CHIP CL2 X7R 10% 100000
C649	2113741N45	CAP CHIP CL2 X7R 10% 10000
C650	2113740B65	CAP CHIP REEL CL1 +/-30 470
C651	2113740B21	CAP CHIP REEL CL1 +/-30 6.8
C652	-----	NOTPLACED
C653	2113740B65	CAP CHIP REEL CL1 +/-30 470
C654	2113741N69	CAP CHIP CL2 X7R 10% 100000 ¹
C661	2113741N45	CAP CHIP CL2 X7R 10% 10000
C662	2113741N69	CAP CHIP CL2 X7R 10% 100000
C663	-----	NOTPLACED ²
C664	-----	NOTPLACED
C665 & C666	2113741N69	CAP CHIP CL2 X7R 10% 100000
C668 & C669	2113740B76	000CAP CHIP REEL CL1 +/-30 1500
C670 thru C672	2113740B76	CAP CHIP REEL CL1 +/-30 1500
C673	2113741N69	CAP CHIP CL2 X7R 10% 100000

ITEM	MOTOROLA PART NUMBER	DESCRIPTION
C674	----- 2113740B65	NOTPLACED ¹ CAP CHIP REEL CL1 +/-30 470 ²
C675	2113741N45	CAP CHIP CL2 X7R 10% 10000
C676	2113740B65 -----	CAP CHIP REEL CL1 +/-30 470 ¹ NOTPLACED ²
C677 & C679	2113740B65	CAP CHIP REEL CL1 +/-30 470
C685	2113740B21	CAP CHIP REEL CL1 +/-30 6.8
C686	2311049J07	CAP TANT CHIP 3.3 10 20
C687	2113740B21	CAP CHIP REEL CL1 +/-30 6.8
C688	2113741N45	CAP CHIP CL2 X7R 10% 10000
C689	2113740B44	CAP CHIP REEL CL1 +/-30 62
C690	2113741N45	CAP CHIP CL2 X7R 10% 10000
C691	2113740B11	CAP CHIP REEL CL1 +/-30 2.7
C692	2113740B65	CAP CHIP REEL CL1 +/-30 470
C700	-----	NOTPLACED ²
C701	2113741N69	CAP CHIP CL2 X7R 10% 100000
C702 & C703	2113740B76	CAP CHIP REEL CL1 +/-30 1500
C704	2113740B30	CAP CHIP REEL CL1 +/-30 16
C705	2113740B29	CAP CHIP REEL CL1 +/-30 15
CR601 & CR602	4880154K03	DIODE DUAL SCHOTTKY MIXER
J3641	0980110M01	RECP COAX PCB MOUNT
J642	0980212N03	RECP COAX PCB MOUNT
JU670 & JU671	-----	NOTPLACED
L3663	2480140E01	INDUCTOR CHIP 1.2 UH
L3664 & L3665	2480140E04	INDUCTOR CHIP 65 NH
L660	2480140E01	INDUCTOR CHIP 1.2 UH
L661 & L662	2480140E03	INDUCTOR CHIP 50 NH
L666 thru L674	2480067M01	CHK RF CHIP BEAD INDUCTOR 28MZ
L675	2480140E01	000INDUCTOR CHIP 1.2 UH
L676	2405452C87	COIL CHIP INDUCTOR 39 5
L677	2480140E01	INDUCTOR CHIP 1.2 UH
L678	2480140E03	INDUCTOR CHIP 50 NH

ITEM	MOTOROLA PART NUMBER	DESCRIPTION
L679	2405452C87	COIL CHIP INDUCTOR 39 5
L681	2480140E03	INDUCTOR CHIP 50 NH
L682 thru L685	2480067M01	CHK RF CHIP BEAD INDUCTOR 28MZ
L686	2405452C87	COIL CHIP INDUCTOR 39 5 ¹
P0601	2880099M02	PLUG VERTICAL
P0602	----- 4280088P01	NOTPLACED ¹ CLIP COAX ²
Q3683	4813827A03	TSTR NPN SML SIG MMBR901LT1 7X
Q642 & Q643	4880141L01	TSTR PNP SOT23 LO PROFILE TAPE
Q644	4880141L01	TSTR PNP SOT23 LO PROFILE TAPE ¹
Q675	4802000P02	NEC SILICON TR 2SC3357 RE
Q677 & Q678	4880141L01	TSTR PNP SOT23 LO PROFILE TAPE
Q681 & Q682	4813827A03	TSTR NPN SML SIG MMBR901LT1 7X
R3663	0611077A62	RES CHIP 330 5 1/8W
R3664	0611077A82	RES CHIP 2200 5 1/8
R3665	-----	NOTPLACED
R3666	0611077A30	RES CHIP 15 5 1/8W
R3667	0611077A66	RES CHIP 470 5 1/8W
R3668	0611077A90	RES CHIP 4700 5 1/8
R3669	-----	NOTPLACED
R636	0611077A94	RES CHIP 6800 5 1/8
R637	0611077B07	RES CHIP 22K 5 1/8W
R639	0611077B15	RES CHIP 47K 5 1/8W
R641	0611077A58	RES CHIP 220 5 1/8W
R642	0611077A90	RES CHIP 4700 5 1/8
R643	0611077A74	RES CHIP 1000 5 1/8
R644	0611077A98	RES CHIP 10K 5 1/8W
R645	0611077A58	RES CHIP 220 5 1/8W
R646 & R647	0611077A98	RES CHIP 10K 5 1/8W
R648 & R649	0611077A70	RES CHIP 680 5 1/8W
R650	0611077A98	RES CHIP 10K 5 1/8W
R651	0611077A54	RES CHIP 150 5 1/8W
R652	0611077A86 -----	RES CHIP 3300 5 1/8 ¹ NOTPLACED ²
R653	0611077A62	RES CHIP 330 5 1/8W
R654	0611077A98	RES CHIP 10K 5 1/8W
R655	0611077A32	RES CHIP 18 5 1/8W
R656	0611077A50	RES CHIP 100 5 1/8W
R657	0611077A30	RES CHIP 15 5 1/8W
R658	-----	NOTPLACED
R659	0611077A78	RES CHIP 1500 5 1/8
R660	0611077A90	RES CHIP 4700 5 1/8
R661	0611077A30	RES CHIP 15 5 1/8W

ITEM	MOTOROLA PART NUMBER	DESCRIPTION
R662	-----	NOTPLACED
R670	0611077A50	RES CHIP 100 5 1/8W
R671	-----	NOTPLACED
R672 & R673	0611077A58	RES CHIP 220 5 1/8W ²
R674	0611077A48	RES CHIP 82 5 1/8W
R675	0611077A50	RES CHIP 100 5 1/8W
R677	0611077A26	RES CHIP 10 5 1/8W
R678 & R679	0611077A62	RES CHIP 330 5 1/8W
R680	0611077A26	RES CHIP 10 5 1/8W
R681	0611077A74	RES CHIP 1000 5 1/8
R682	0611077A74	RES CHIP 1000 5 1/8
R683	0611077A48	RES CHIP 82 5 1/8W
R684	0611077A86	RES CHIP 3300 5 1/8
R685	0611077A98	RES CHIP 10K 5 1/8W
R699	0611077A43	RES CHIP 10 5 1/8W
R700	0611077A62	RES CHIP 330 5 1/8W
R701	0611077A26	RES CHIP 10 5 1/8W
R702	0611077A98	RES CHIP 10K 5 1/8W ¹
T601	2405548Q06	TRANSFORMER, RF
T602	2405548Q06	TRANSFORMER, RF
	1280954T43	SPECTRA VHF VCO ASSEMBLY

Notes:

- Valid in HLD4342D only.
- Valid in HLD4343D only.

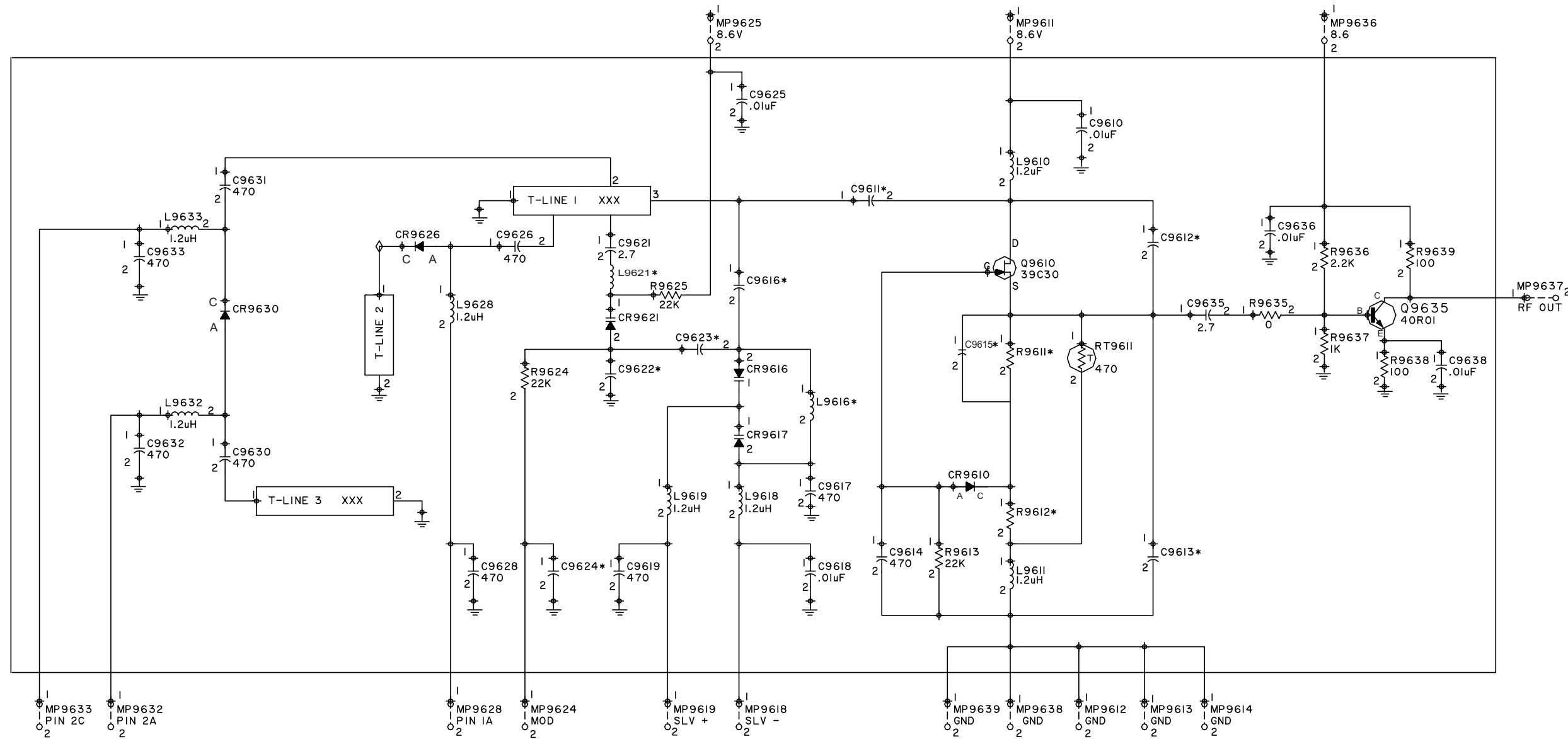

AUX1 =1= LO BS=PIN 1 OFF
 =0= HI BS=PIN 1 ON
 AUX2 =1= TX =PIN 2 OFF
 =0= RX =PIN 2 ON

* = SEE PARTS LISTS

GXW-5851

UHF VCO Ranges 1, 2, 3, and 4 Hybrid Schematic

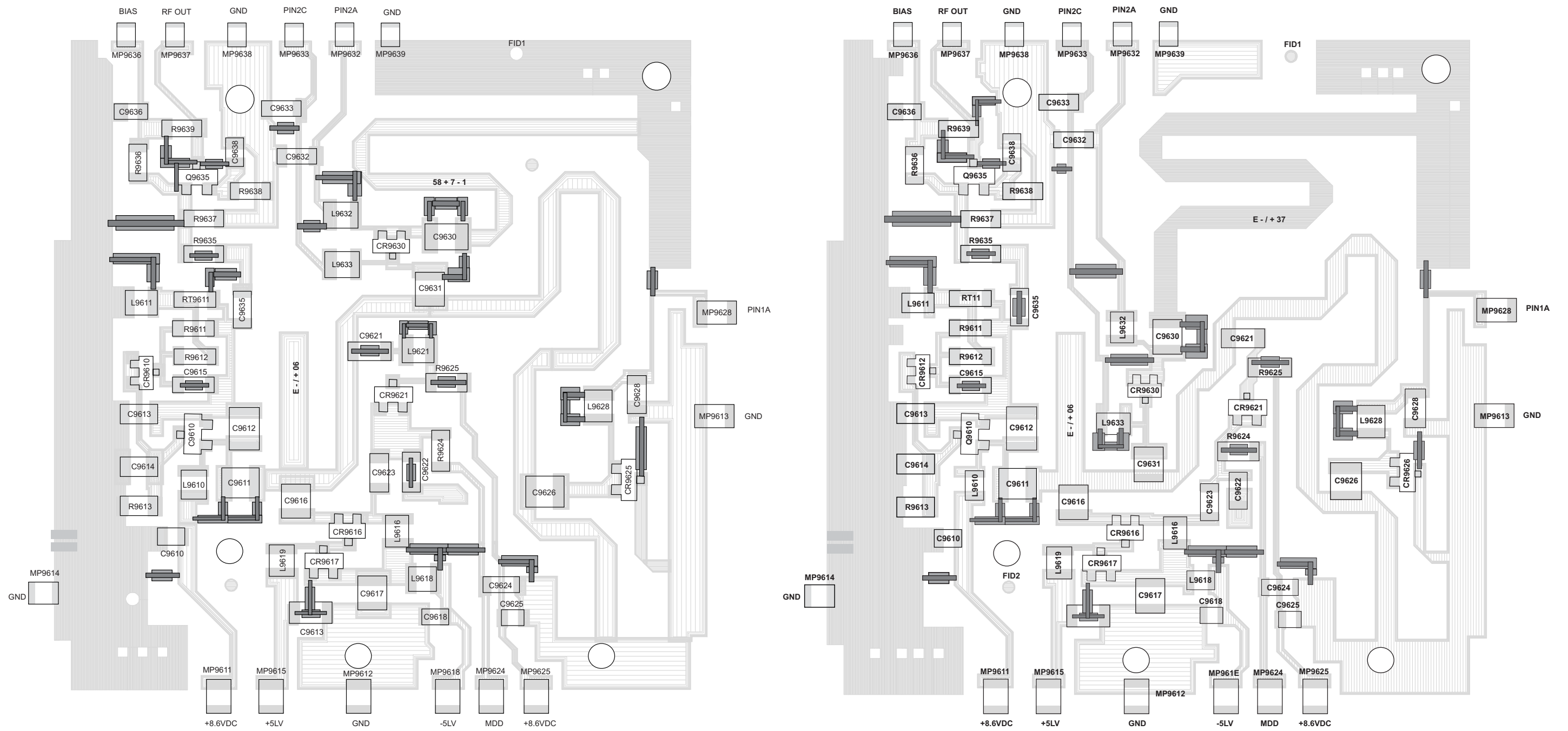

Note: These components are shown for reference only. Hybrid assemblies are not considered repairable.

HLE6101A UHF VCO Range 1 Hybrid and HLE6102A Range 2 Hybrid Component Location Diagram

**HLE6101A UHF VCO Range 1 Hybrid and HLE6102A
UHF VCO Range 2 Hybrid Parts List**

ITEM	MOTOROLA PART NUMBER	DESCRIPTION
C9610	2111059B11	CAP CHIP 21D84547A11 A/I
C9611	2111078B29	CAP CHIP RF 33 5 NPO 100V ¹
	2111078B27	CAP CHIP RF 30 5 NPO 100V ²
C9612	2111078B14	CAP CHIP RF 11 5 NPO 100V
C9613	2111078B20	CAP CHIP RF 18 5 NPO 100V
C9614	2111078B59	CAP CHIP RF 470 5 NPO 100V
C9615	2113740B65	CAP CHIP REEL CL1 +/-30 470
C9616	2111078B14	CAP CHIP RF 11 5 NPO 100V ¹
	2111078B15	CAP CHIP RF 12 5 NPO 100V ²
C9617	2111078B59	CAP CHIP RF 470 5 NPO 100V
C9618	2111059B11	CAP CHIP 21D84547A11 A/I
C9619	2113740B65	CAP CHIP REEL CL1 +/-30 470
C9621	2113740B07	CAP CHIP REEL CL1 +/-30 1.8 ¹
	2113740B11	CAP CHIP REEL CL1 +/-30 2.7 ²
C9622	2113740B29	CAP CHIP REEL CL1 +/-30 15 ¹
	2113740B27	CAP CHIP REEL CL1 +/-30 12 ²
C9623	2113740B05	CAP CHIP REEL CL1 +/-30 1.5
C9624	2113740B76	CAP CHIP REEL CL1 +/-30 1500
C9625	2111059B11	CAP CHIP 21D84547A11 A/I
C9626	2111078B59	CAP CHIP RF 470 5 NPO 100V
C9628	2113740B65	CAP CHIP REEL CL1 +/-30 470
C9630 & C9631	2111078B59	CAP CHIP RF 470 5 NPO 100V
C9632 & C9633	2113740B65	CAP CHIP REEL CL1 +/-30 470
C9635	2113740B11	CAP CHIP REEL CL1 +/-30 2.7
C9636 & C9638	2111059B11	CAP CHIP 21D84547A11 A/I
CR9610	4813825A05	DIODE 30V HOT CARRIER MMBD301L
CR9616 & CR9617	4880006E13	DIODE VAR SI SMBV1050 350MW

ITEM	MOTOROLA PART NUMBER	DESCRIPTION
CR9621	4880006E13	DIODE VAR SI SMBV1050 350MW
CR9626 & CR9630	4880142L01	DIODE PIN SOT 23 MMBV 3401
L9610 & L9611	2480140E01	INDUCTOR CHIP 1.2 UH
L9616	2480140E04	INDUCTOR CHIP 65 NH
L9618 & L9619	2480140E01	INDUCTOR CHIP 1.2 UH
L9621	2480140E03	INDUCTOR CHIP 50 NH ¹
L9628, L9632, & L9633	2480140E01	INDUCTOR CHIP 1.2 UH
MP9611 thru MP9614,	0780299L01	FRAME LEAD J STRAP
MP9618 & M9619	0780299L01	FRAME LEAD J STRAP
MP9624 & M9625	0780299L01	FRAME LEAD J STRAP
MP9628	0780299L01	FRAME LEAD J STRAP
MP9632 & M9633	0780299L01	FRAME LEAD J STRAP
MP9636 thru M9639	0780299L01	FRAME LEAD J STRAP
Q9610	4880141L06	TSTR NC MOS FET SOT23 TGR MMBF
Q9635	4813827A03	TSTR NPN SML SIG MMBR901LT1 7X
R9611	0611077A46	RES CHIP 68 5 1/8W
R9612	0611077A32	RES CHIP 18 5 1/8W
R9613	0611077B07	RES CHIP 22K 5 1/8W
R9624 & R9625	0611077B07	RES CHIP 22K 5 1/8W
R9635	0611077A01	RES CHIP JUMPER
R9636	0611077A82	RES CHIP 2200 5 1/8
R9637	0611077A74	RES CHIP 1000 5 1/8
R9638 & R9639	0611077A50	RES CHIP 100 5 1/8W
RT9611	0680149M01	THERMISTOR CHIP 470 OHMS
	8480034P02	HYBRID CKT BD UHF VCO R1

Notes:

- Valid in HLE6101A only.
- Valid in HLE6102A only.

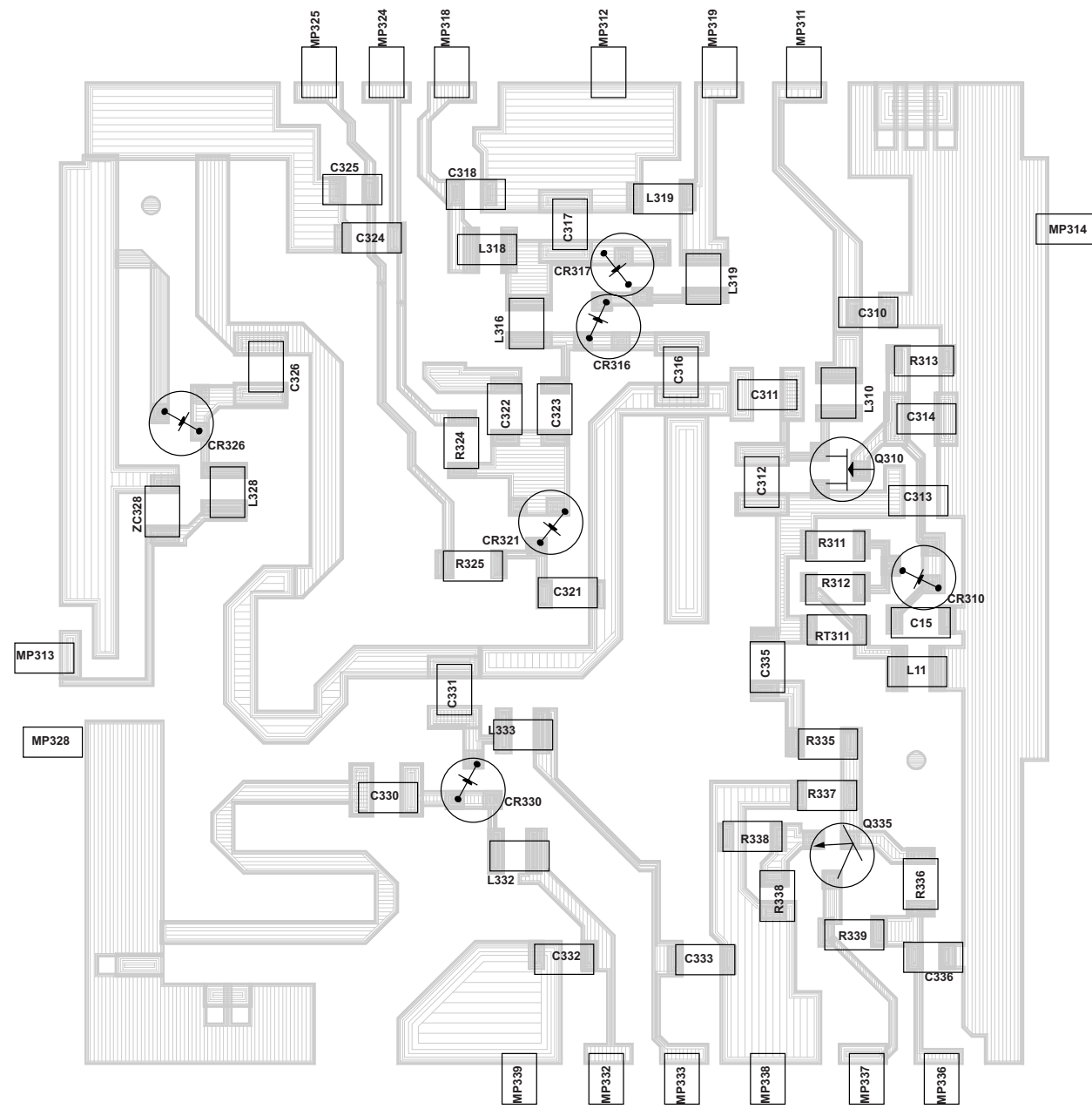

Range 3

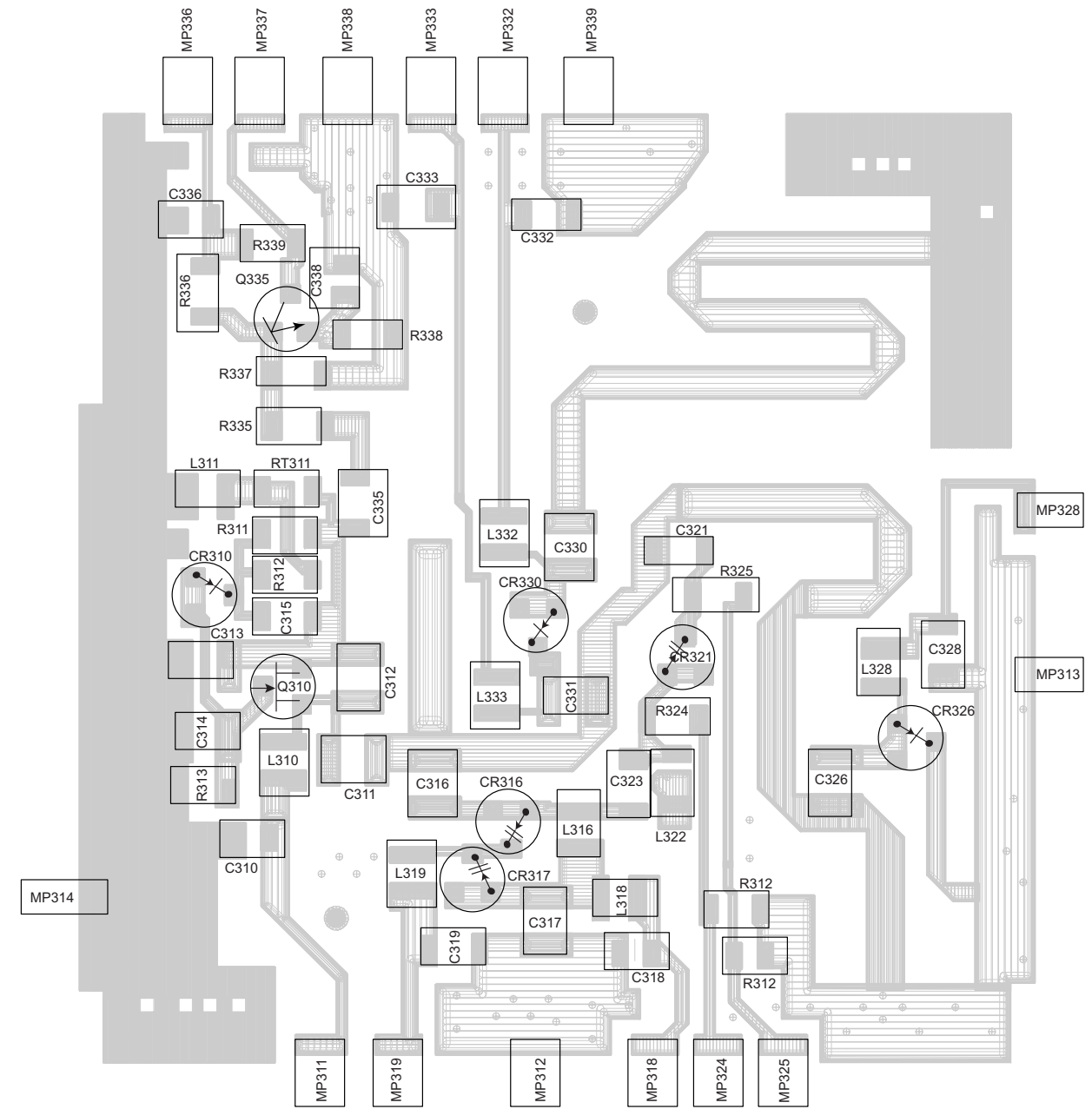

Range 4

HLE6103B UHF VCO Range 3 Hybrid and HLE6104B Range 4 Hybrid Component Location Diagram

**HLE6103B UHF VCO Range 3 Hybrid and HLE6104B
UHF VCO Range 4 Hybrid Parts List**

ITEM	MOTOROLA PART NUMBER	DESCRIPTION
C9610	2111059B11	CAP CHIP 21D84547A11 A/I
C9611	2111078B22	CAP CHIP RF 22 5 NPO 100V
C9612 & C9613	2111078B15	CAP CHIP RF 12 5 NPO 100V
C9614	2111078B59	CAP CHIP RF 470 5 NPO 100V
C9615	2113740B65	CAP CHIP REEL CL1 +/-30 470 2
C9616	2111078B18 2111078B14	CAP CHIP RF 15 5 NPO 100V ¹ CAP CHIP RF 11 5 NPO 100V ²
C9617	2111078B59	CAP CHIP RF 470 5 NPO 100V
C9618	2111059B11	CAP CHIP 21D84547A11 A/I
C9619	2113740B65	CAP CHIP REEL CL1 +/-30 470
C9621	2113740B11	CAP CHIP REEL CL1 +/-30 2.7
C9622	2113740B15 2113740B31	CAP CHIP REEL CL1 +/-30 3.9 ¹ CAP CHIP REEL CL1 +/-30 18 ²
C9623	2113740B05	CAP CHIP REEL CL1 +/-30 1.5
C9624	2113740B76	CAP CHIP REEL CL1 +/-30 1500
C9625	2111059B11	CAP CHIP 21D84547A11 A/I
C9626	2111078B59	CAP CHIP RF 470 5 NPO 100V
C9628	2113740B65	CAP CHIP REEL CL1 +/-30 470
C9630 & C9631	2111078B59	CAP CHIP RF 470 5 NPO 100V
C9632	2113740B65	CAP CHIP REEL CL1 +/-30 470
C9633	2113740B65	CAP CHIP REEL CL1 +/-30 470
C9635	2113740B11	CAP CHIP REEL CL1 +/-30 2.7
C9636 & C9638	2111059B11	CAP CHIP 21D84547A11 A/I
CR9610	4813825A05	DIODE 30V HOT CARRIER MMBD301L
CR9616	4880006E13	DIODE VAR SI SMBV1050 350MW
CR9617 & CR9621	4880006E13	DIODE VAR SI SMBV1050 350MW
CR9626 & CR9630	4880154K05	DIODE CMN CATH DUAL PIN SOT23
L9610 & L9611	2480140E01	INDUCTOR CHIP 1.2 UH
L9616	2480140E06 2480140E04	INDUCTOR CHIP 130 NH ¹ INDUCTOR CHIP 65 NH ²
L9618 & L8619	2480140E01	INDUCTOR CHIP 1.2 UH
L9628	2480140E01	INDUCTOR CHIP 1.2 UH
L9632 & L9633	2480140E01	INDUCTOR CHIP 1.2 UH
MP9611 thru MP9614	0780299L01	FRAME LEAD J STRAP

ITEM	MOTOROLA PART NUMBER	DESCRIPTION
MP9618 & MP9619	0780299L01	FRAME LEAD J STRAP
MP9624 & MP9625	0780299L01	FRAME LEAD J STRAP
MP9628	0780299L01	FRAME LEAD J STRAP
MP9632 & MP9633	0780299L01	FRAME LEAD J STRAP
MP9636 thru MP9639	0780299L01	FRAME LEAD J STRAP
Q9610	4880141L06	TSTR NC MOS FET SOT23 TGR MMBF
Q9635	4813827A03	TSTR NPN SML SIG MMBR901LT1 7X
R9611	0611077A32 0611077A43	RES CHIP 18 5 1/8W ¹ RES CHIP 51 5 1/8W ²
R9612	0611077A46 0611077A43	RES CHIP 68 5 1/8W ¹ RES CHIP 51 5 1/8W ²
R9613	0611077B07	RES CHIP 22K 5 1/8W
R9624 & R9625	0611077B07	RES CHIP 22K 5 1/8W
R9635	0611077A01	RES CHIP JUMPER
R9636	0611077A82	RES CHIP 2200 5 1/8
R9637	0611077A74	RES CHIP 1000 5 1/8
R9638	0611077A50	RES CHIP 100 5 1/8W
R9639	0611077A50	RES CHIP 100 5 1/8W
RT9611	0680149M01 8480036P02	THERMISTOR CHIP 470 OHMS BD CKT HYBRID

Notes:

1. Valid in HLE6103B only.
2. Valid in HLE6104B only.

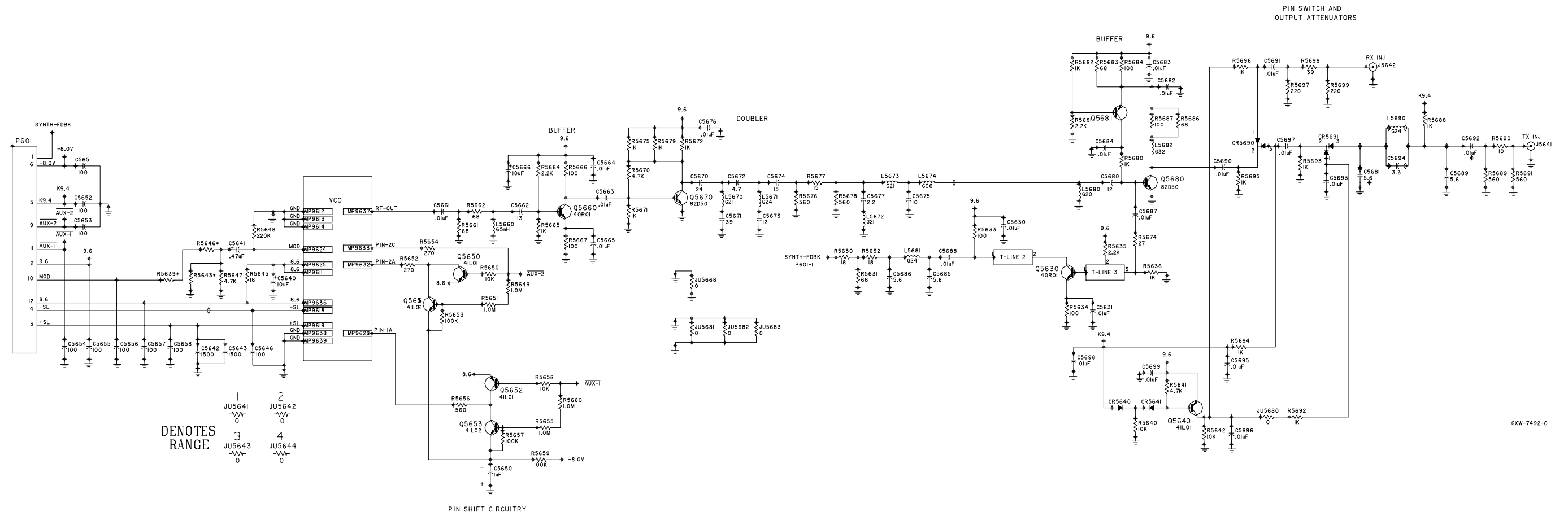

UHF VCO Ranges 1, 2, 3, and 4 Schematic Diagram

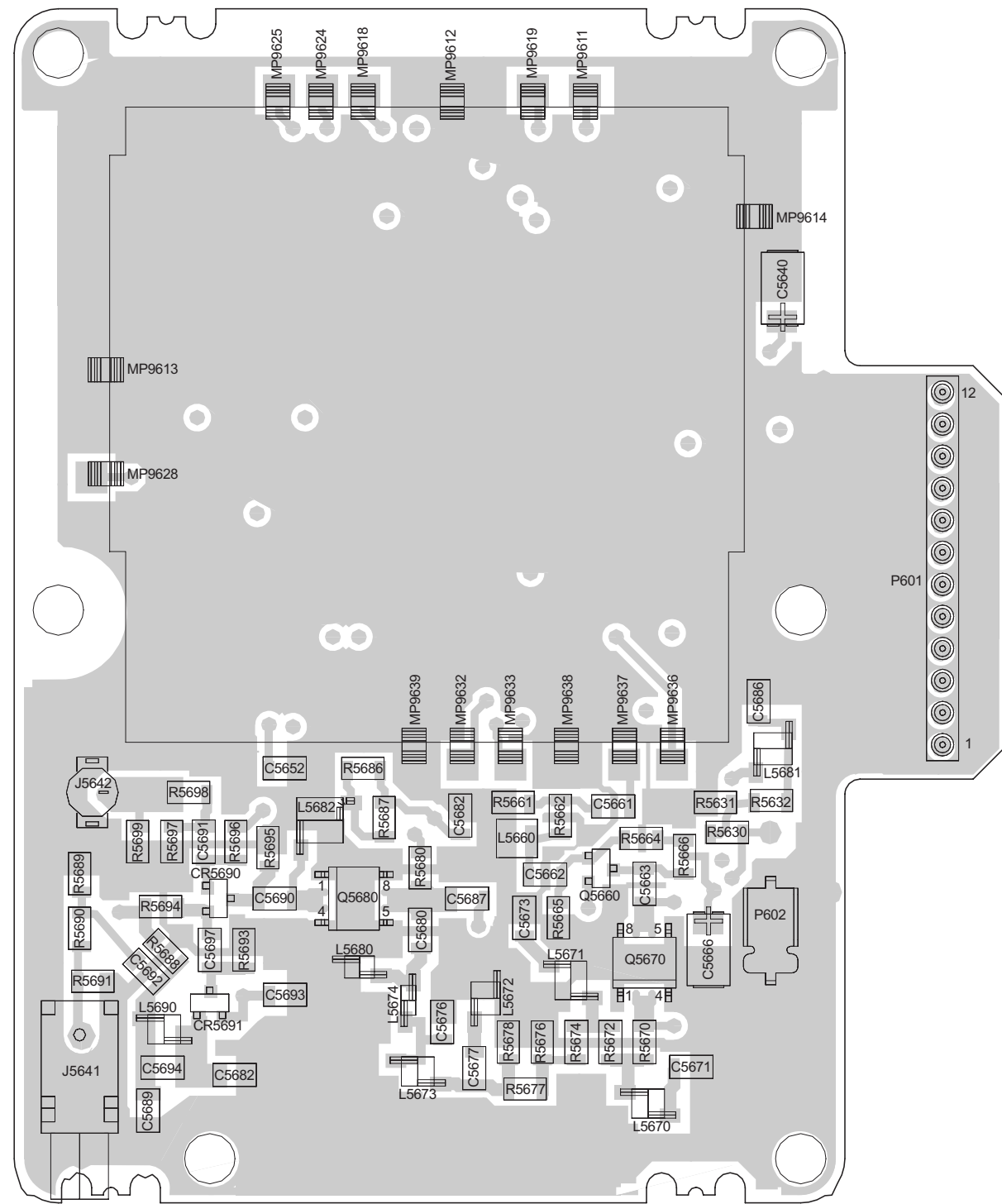

Side 1

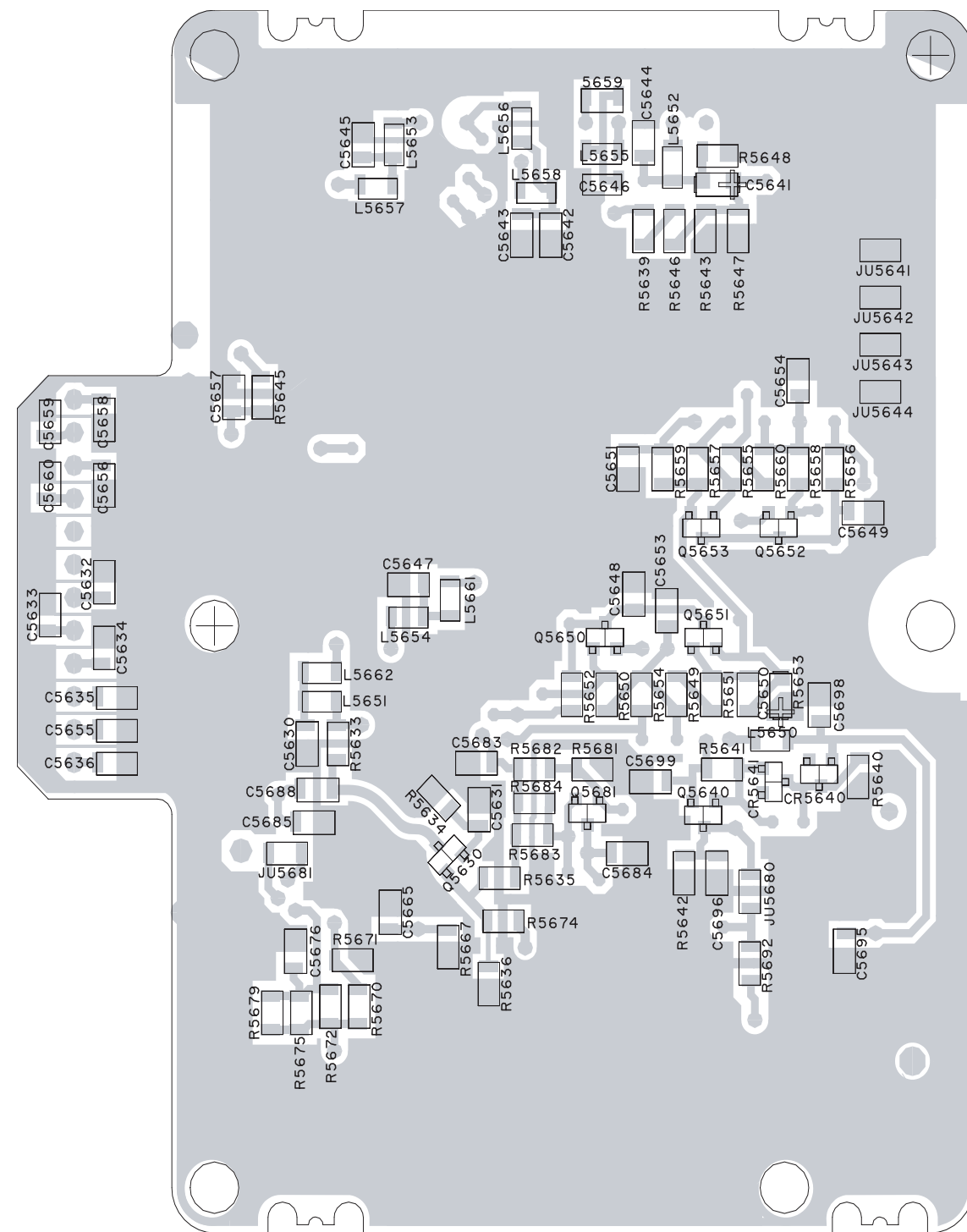

Side 2

HLE6045B Range 1 and HLE6046B Range 2 UHF VCO Component Location Diagram

HLE6000D and HLE6041D UHF VCO Parts List

ITEM	MOTOROLA PART NUMBER	DESCRIPTION
C5630 & C5631	2113741N45	CAP CHIP CL2 X7R 10% 10000
C5640	2311049J26	CAP TANT CHIP 10 20 16
C5641	2311049A35	CAP TANT CHIP 0.47 20 25
C5642 & C5643	2113740B76	CAP CHIP REEL CL1 +/-30 1500
C5646	2113740B49	CAP CHIP REEL CL1 +/-30 100
C5650	2311049A37	CAP TANT CHIP 1 20 20
C5651 thru C5658	2113740B49	CAP CHIP REEL CL1 +/-30 100
C5661	2113741N45	CAP CHIP CL2 X7R 10% 10000
C5662	2113740B28	CAP CHIP REEL CL1 +/-30 13
C5663 thru C5665	2113741N45	CAP CHIP CL2 X7R 10% 10000
C5666	2311049J26	CAP TANT CHIP 10 20 16
C5670	2113740B34	CAP CHIP REEL CL1 +/-30 24
C5671	2113740B39	CAP CHIP REEL CL1 +/-30 39
C5672	2113740B17	CAP CHIP REEL CL1 +/-30 4.7
C5673	2113740B27	CAP CHIP REEL CL1 +/-30 12
C5674	2113740B29	CAP CHIP REEL CL1 +/-30 15
C5675	2113740B25	CAP CHIP REEL CL1 +/-30 10
C5676	2113741N45	CAP CHIP CL2 X7R 10% 10000
C5677	2113740B09	CAP CHIP REEL CL1 +/-30 2.2
C5680	2113740B27	CAP CHIP REEL CL1 +/-30 12
C5682 thru C5684	2113741N45	CAP CHIP CL2 X7R 10% 10000
C5685 & C5686	2113740B19	CAP CHIP REEL CL1 +/-30 5.6
C5687 & C5688	2113741N45	CAP CHIP CL2 X7R 10% 10000
C5690 thru C5693	2113741N45	CAP CHIP CL2 X7R 10% 10000
C5695 thru C5699	2113741N45	CAP CHIP CL2 X7R 10% 10000
CR5640 & CR5641	4880066M01	DIODE SIGNAL RLS4148
CR5690 & CR5691	4880154K05	DIODE CMN CATH DUAL PIN SOT23
J5641	0980110M01	RECP COAX PCB MOUNT

ITEM	MOTOROLA PART NUMBER	DESCRIPTION
J5642	0980212N03	RECP COAX PCB MOUNT
JU5641 & JU5642	-----	NOTPLACED
JU5643	0611077A01	RES CHIP JUMPER ¹ NOTPLACED ²
JU5644	-----	NOTPLACED ¹ RES CHIP JUMPER ²
JU5668	0611077A01	RES CHIP JUMPER
JU5669	-----	NOTPLACED
JU5680 thru Ju5683	0611077A01	RES CHIP JUMPER
L5660	2480140E04	INDUCTOR CHIP 65 NH
L5670	2480091G21	COIL AIRWOUND
L5671	2480091G24	COIL AIRWOUND
L5672 & L5673	2480091G21	COIL AIRWOUND
L5674	2480091G06	COIL AIRWOUND
L5680	2480091G20	COIL AIRWOUND
L5681	2480091G24	COIL AIRWOUND
L5682	2480091G32	COIL AIRWOUND
L5683	-----	NOTPLACED
MP5655	1180117M01	ADHESIVE PREFORM VCO
MP5676	1580223N02	COVER SHIELD
P0601	2880099M02	PLUG VERTICAL
Q5630	4813827A03	TSTR NPN SML SIG MMBR901LT1 7X
Q5640 & Q5650	4880141L01	TSTR PNP SOT23 LO PROFILE TAPE
Q5651	4880141L02	TSTR NPN SOT23 LO PROFILE TAPE
Q5652	4880141L01	TSTR PNP SOT23 LO PROFILE TAPE
Q5653	4880141L02	TSTR NPN SOT23 LO PROFILE TAPE
Q5660	4813827A03	TSTR NPN SML SIG MMBR901LT1 7X
Q5670 & Q5680	4880182D50	TSTR SI SORF 4V 750MW 960MHZ
Q5681	4880141L01	TSTR PNP SOT23 LO PROFILE TAPE
R5630	0611077A32	RES CHIP 18 5 1/8W
R5631	0611077A46	RES CHIP 68 5 1/8W
R5632	0611077A32	RES CHIP 18 5 1/8W
R5633	0611077A50	RES CHIP 100 5 1/8W
R5634	0611077A50	RES CHIP 100 5 1/8W
R5635	0611077A82	RES CHIP 2200 5 1/8
R5636	0611077A74	RES CHIP 1000 5 1/8
R5639	0611077A01	RES CHIP JUMPER ¹ RES CHIP 6800 5 1/8 ²
R5640	0611077A98	RES CHIP 10K 5 1/8W
R5641	0611077A90	RES CHIP 4700 5 1/8

ITEM	MOTOROLA PART NUMBER	DESCRIPTION
R5642	0611077A98	RES CHIP 10K 5 1/8W
R5643	0611077B07 0611077A90	RES CHIP 22K 5 1/8W ¹ RES CHIP 4700 5 1/8 ²
R5645	0611077A32	RES CHIP 18 5 1/8W
R5646	0611077B19	RES CHIP 68K 5 1/8W
R5647	0611077A90	RES CHIP 4700 5 1/8
R5648	0611077B31	RES CHIP 220K 5 1/8W
R5649	0611077B47	RES CHIP 1 MEG 5 1/8W
R5650	0611077A98	RES CHIP 10K 5 1/8W
R5651	0611077B47	RES CHIP 1 MEG 5 1/8W
R5652	0611077A60	RES CHIP 270 5 1/8W
R5653	0611077B23	RES CHIP 100K 5 1/8W
R5654	0611077A60	RES CHIP 270 5 1/8W
R5655	0611077B47	RES CHIP 1 MEG 5 1/8W
R5656	0611077A68	RES CHIP 560 5 1/8W
R5657	0611077B23	RES CHIP 100K 5 1/8W
R5658	0611077A98	RES CHIP 10K 5 1/8W
R5659	0611077B23	RES CHIP 100K 5 1/8W
R5660	0611077B47	RES CHIP 1 MEG 5 1/8W
R5661 & R5662	0611077A46	RES CHIP 68 5 1/8W
R5664	0611077A82	RES CHIP 2200 5 1/8
R5665	0611077A74	RES CHIP 1000 5 1/8
R5666 & R5667	0611077A50	RES CHIP 100 5 1/8W
R5670	0611077A90	RES CHIP 4700 5 1/8
R5671 & R5672	0611077A74	RES CHIP 1000 5 1/8
R5674	0611077A36	RES CHIP 27 5 1/8W
R5675	0611077A74	RES CHIP 1000 5 1/8
R5676	0611077A68	RES CHIP 560 5 1/8W
R5677	0611077A30	RES CHIP 15 5 1/8W
R5678	0611077A68	RES CHIP 560 5 1/8W
R5679 & R5680	0611077A74	RES CHIP 1000 5 1/8
R5681	0611077A82	RES CHIP 2200 5 1/8
R5682	0611077A74	RES CHIP 1000 5 1/8
R5683	0611077A46	RES CHIP 68 5 1/8W
R5684	0611077A50	RES CHIP 100 5 1/8W
R5686	0611077A46	RES CHIP 68 5 1/8W
R5687	0611077A50	RES CHIP 100 5 1/8W
R5688	0611077A74	RES CHIP 1000 5 1/8
R5689	0611077A68	RES CHIP 560 5 1/8W
R5690	0611077A26	RES CHIP 10 5 1/8W
R5691	0611077A68	RES CHIP 560 5 1/8W
R5692 thru R5696	0611077A74	RES CHIP 1000 5 1/8
R5697	0611077A58	RES CHIP 220 5 1/8W
R5698	0611077A40	RES CHIP 39 5 1/8W
R5699	0611077A58	RES CHIP 220 5 1/8W
	3280247N01	GASKET VCO

ITEM	MOTOROLA PART NUMBER	DESCRIPTION
	8480208N37	BD CKT UHF VCO CAR BFRPNL
	8480208N07	BD CKT UHF VCO CAR BFR

Notes:

1. Valid in HLE6000D only.
2. Valid in HLE6041D only.

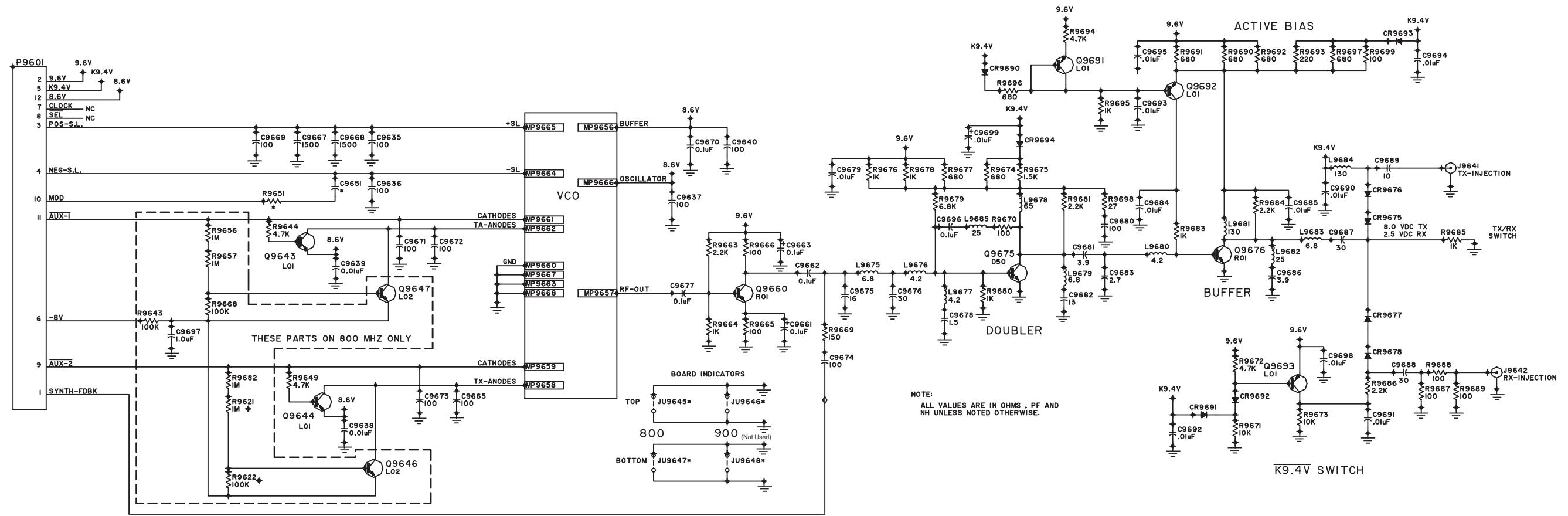

6XW-6402-A

HLF6080B 800 MHz VCO Schematic Diagram

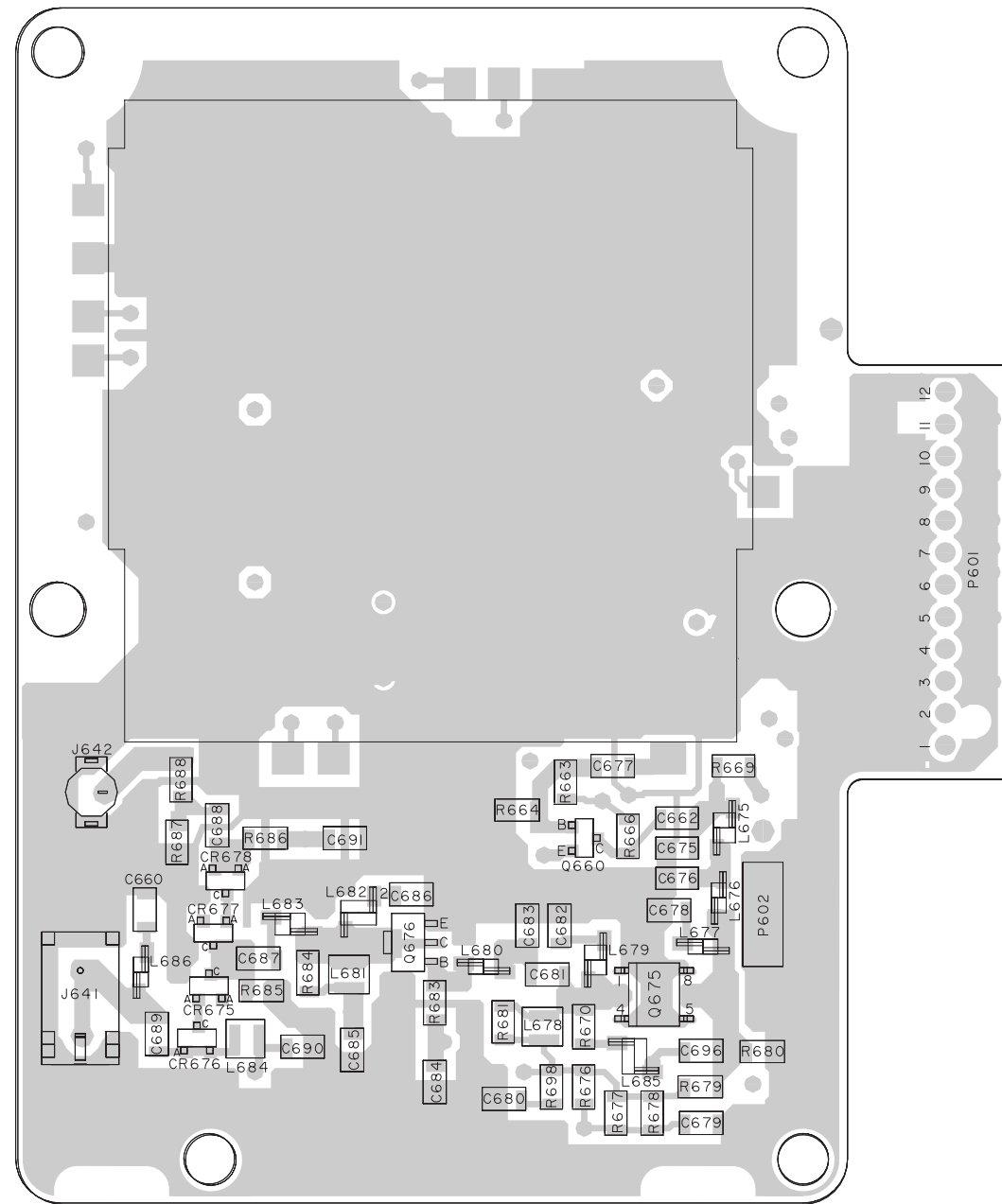

Side 1

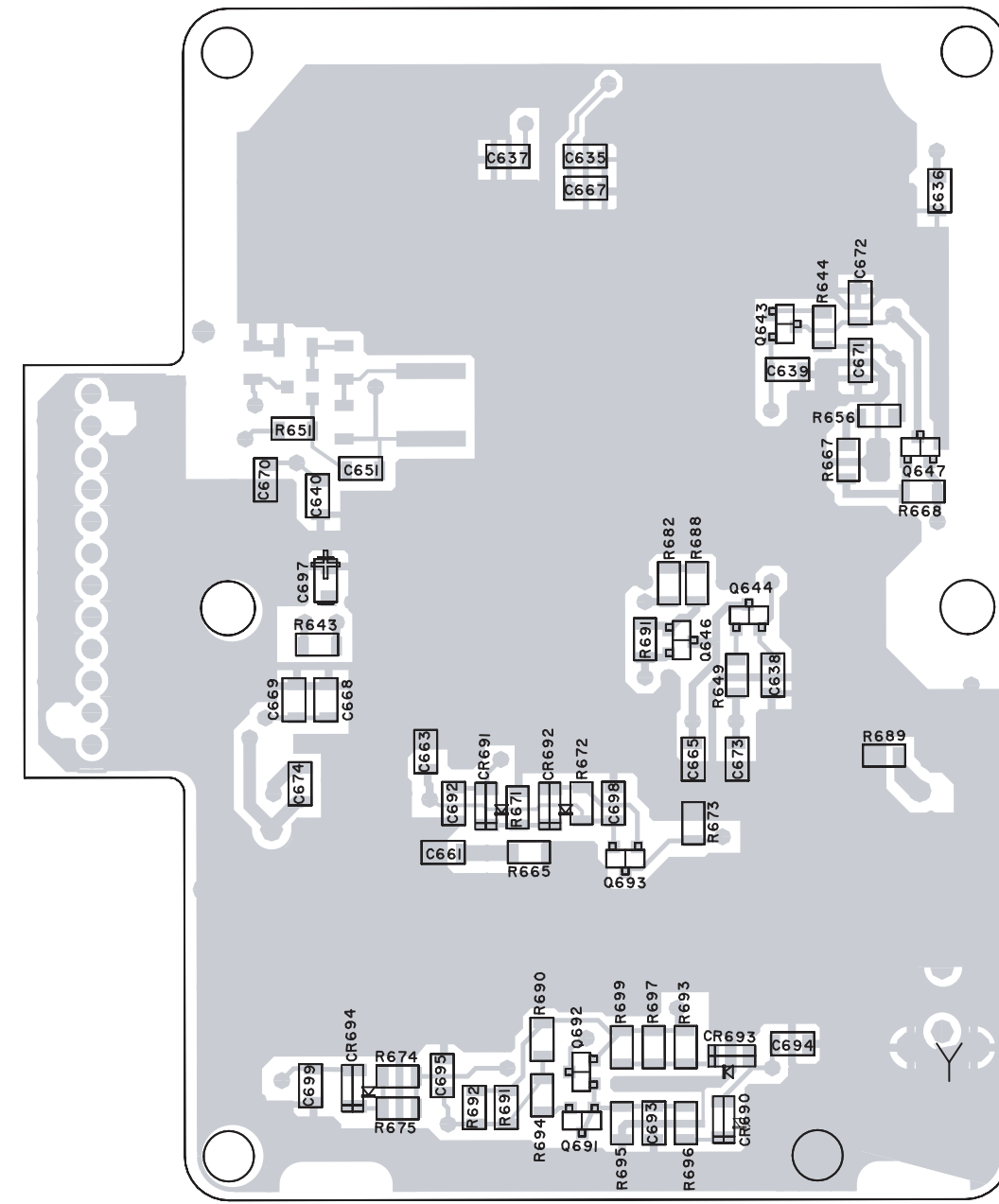

Side 2

HLF6080B 800 MHz VCO Component Location Diagram

HLF6080B 800 MHz VCO Parts List

ITEM	MOTOROLA PART NUMBER	DESCRIPTION
C635 thru C637	2113740B49	CAP CHIP REEL CL1 +/-30 100
C638 & C639	2113741N45	CAP CHIP CL2 X7R 10% 10000
C640	2113740B49	CAP CHIP REEL CL1 +/-30 100
C649	2113741N69	CAP CHIP CL2 X7R 10% 100000
C650	-----	NOTPLACED
C651	2113740B69	CAP CHIP REEL CL1 +/-30 680
C660	-----	NOTPLACED
C661 thru C663	2113741N69	CAP CHIP CL2 X7R 10% 100000
C665	2113740B49	CAP CHIP REEL CL1 +/-30 100
C666	-----	NOTPLACED
C667 & C668	2113740B76	CAP CHIP REEL CL1 +/-30 1500
C669	2113740B49	CAP CHIP REEL CL1 +/-30 100
C670	2113741N69	CAP CHIP CL2 X7R 10% 100000
C671 thru C674	2113740B49	CAP CHIP REEL CL1 +/-30 100
C675	2113740B30	CAP CHIP REEL CL1 +/-30 16
C676	2113740B36	CAP CHIP REEL CL1 +/-30 30
C677	2113741N69	CAP CHIP CL2 X7R 10% 100000
C678	2113740B05	CAP CHIP REEL CL1 +/-30 1.5
C679	2113741N45	CAP CHIP CL2 X7R 10% 10000
C680	2113740B49	CAP CHIP REEL CL1 +/-30 100
C681	2113740B15	CAP CHIP REEL CL1 +/-30 3.9
C682	2113740B28	CAP CHIP REEL CL1 +/-30 13
C683	2113740B11	CAP CHIP REEL CL1 +/-30 2.7
C684	2113741N45	CAP CHIP CL2 X7R 10% 10000
C685	2111078B27	CAP CHIP RF 30 5 NPO 100V
C686	2113740B15	CAP CHIP REEL CL1 +/-30 3.9
C687 & C688	2113740B36	CAP CHIP REEL CL1 +/-30 30
C689	2113740B25	CAP CHIP REEL CL1 +/-30 10
C690 & C691	2111078B27	CAP CHIP RF 30 5 NPO 100V
C692 thru C695	2113741N45	CAP CHIP CL2 X7R 10% 10000
C696	2113741N69	CAP CHIP CL2 X7R 10% 100000
C697	2311049A37	CAP TANT CHIP 1 20 20
C698 & C699	2113741N45	CAP CHIP CL2 X7R 10% 10000
CR675 thru CR678	4880142L01	DIODE PIN SOT 23 MMBV 3401

ITEM	MOTOROLA PART NUMBER	DESCRIPTION
CR690 thru CR694	4880066M01	DIODE SIGNAL RLS4148
E9677	8480154P01	BD CKT 800 VCO CARRIER
E9677	8480154P31	BD CKT 800 VCO CARRIER PNL
J641	0980110M01	RECP COAX PCB MOUNT
J642	0980212N03	RECP COAX PCB MOUNT
JU645	0611077A01	RES CHIP JUMPER
JU646	-----	NOTPLACED
JU647	0611077A01	RES CHIP JUMPER
JU648	-----	NOTPLACED
L675	2480091G20	COIL AIRWOUND
L676	2480091G06	COIL AIRWOUND
L677	2480091G06	COIL AIRWOUND
L678	2480140E04	INDUCTOR CHIP 65 NH
L679	2480091G20	COIL AIRWOUND
L680	2480091G06	COIL AIRWOUND
L681	2480140E06	INDUCTOR CHIP 130 NH
L682	2480091G01	COIL AIRWOUND
L683	2480091G20	COIL AIRWOUND
L684	2480140E06	INDUCTOR CHIP 130 NH
L685	2480091G01	COIL AIRWOUND
L686	-----	NOTPLACED
MP9655	1180117M01	ADHESIVE PREFORM VCO
MP9676	1580223N02	COVER SHIELD
P601	2880099M02	PLUG VERTICAL
Q643	4880141L01	TSTR PNP SOT23 LO PROFILE TAPE
Q644	4880141L01	TSTR PNP SOT23 LO PROFILE TAPE
Q645	-----	NOTPLACED
Q646	4880141L02	TSTR NPN SOT23 LO PROFILE TAPE
Q647	4880141L02	TSTR NPN SOT23 LO PROFILE TAPE
Q660	4813827A03	TSTR NPN SML SIG MMBR901LT1 7X
Q675	4880182D50	TSTR SI SORF 4V 750MW 960MHZ
Q676	4802000P02	NEC SILICON TR 2SC3357 RE
Q691 thru Q693	4880141L01	TSTR PNP SOT23 LO PROFILE TAPE
R621	0611077B47	RES CHIP 1 MEG 5 1/8W
R622	0611077B23	RES CHIP 100K 5 1/8W
R643	0611077B23	RES CHIP 100K 5 1/8W
R644 & R649	0611077A90	RES CHIP 4700 5 1/8
R650	NOTPLACED	64AM DUMMY PART NUMBER
R651	0611077A94	RES CHIP 6800 5 1/8
R656 & R657	0611077B47	RES CHIP 1 MEG 5 1/8W

ITEM	MOTOROLA PART NUMBER	DESCRIPTION
R662	-----	NOTPLACED
R663	0611077A82	RES CHIP 2200 5 1/8
R664	0611077A74	RES CHIP 1000 5 1/8
R665 & R666	0611077A50	RES CHIP 100 5 1/8W
R668	0611077B23	RES CHIP 100K 5 1/8W
R669	0611077A54	RES CHIP 150 5 1/8W
R670	0611077A50	RES CHIP 100 5 1/8W
R671	0611077A98	RES CHIP 10K 5 1/8W
R672	0611077A90	RES CHIP 4700 5 1/8
R673	0611077A98	RES CHIP 10K 5 1/8W
R674	0611077A70	RES CHIP 680 5 1/8W
R675	0611077A78	RES CHIP 1500 5 1/8
R676	0611077A74	RES CHIP 1000 5 1/8
R677	0611077A70	RES CHIP 680 5 1/8W
R678	0611077A74	RES CHIP 1000 5 1/8
R679	0611077A94	RES CHIP 6800 5 1/8
R680	0611077A74	RES CHIP 1000 5 1/8
R681	0611077A82	RES CHIP 2200 5 1/8
R682	0611077B47	RES CHIP 1 MEG 5 1/8W
R683	0611077A74	RES CHIP 1000 5 1/8
R684	0611077A82	RES CHIP 2200 5 1/8
R685	0611077A74	RES CHIP 1000 5 1/8
R686	0611077A82	RES CHIP 2200 5 1/8
R687	0611077A50	RES CHIP 100 5 1/8W
R688	0611077A46	RES CHIP 68 5 1/8W
R689	0611077A50	RES CHIP 100 5 1/8W
R690	0611077A70	RES CHIP 680 5 1/8W
R691 & R692	0611077A70	RES CHIP 680 5 1/8W
R693	0611077A58	RES CHIP 220 5 1/8W
R694	0611077A90	RES CHIP 4700 5 1/8
R695	0611077A74	RES CHIP 1000 5 1/8
R696 & R697	0611077A70	RES CHIP 680 5 1/8W
R698	0611077A36	RES CHIP 27 5 1/8W
R699	0611077A50	RES CHIP 100 5 1/8W
	3280247N01	GASKET VCO

7.7 RX Front-End Section

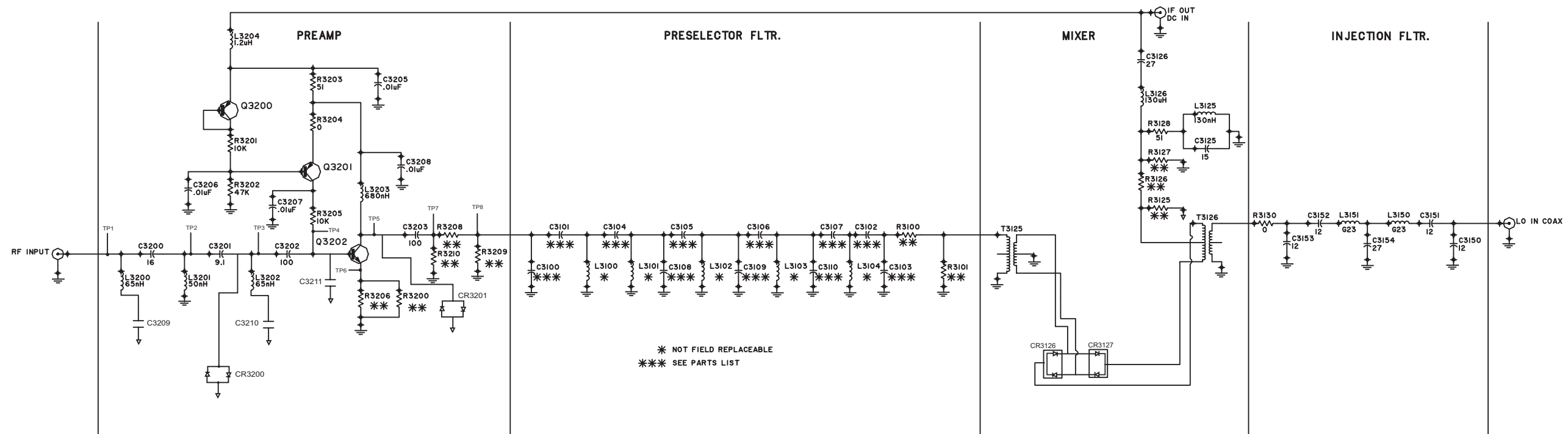

NOTE:
ALL RESISTANCE IN OHMS. ALL CAPACITANCE
IN PICO FARADS UNLESS OTHERWISE NOTED.

GXW-5910-B

HRD6001E/6002E/6011E/6012E VHF Receiver Front-End Schematic

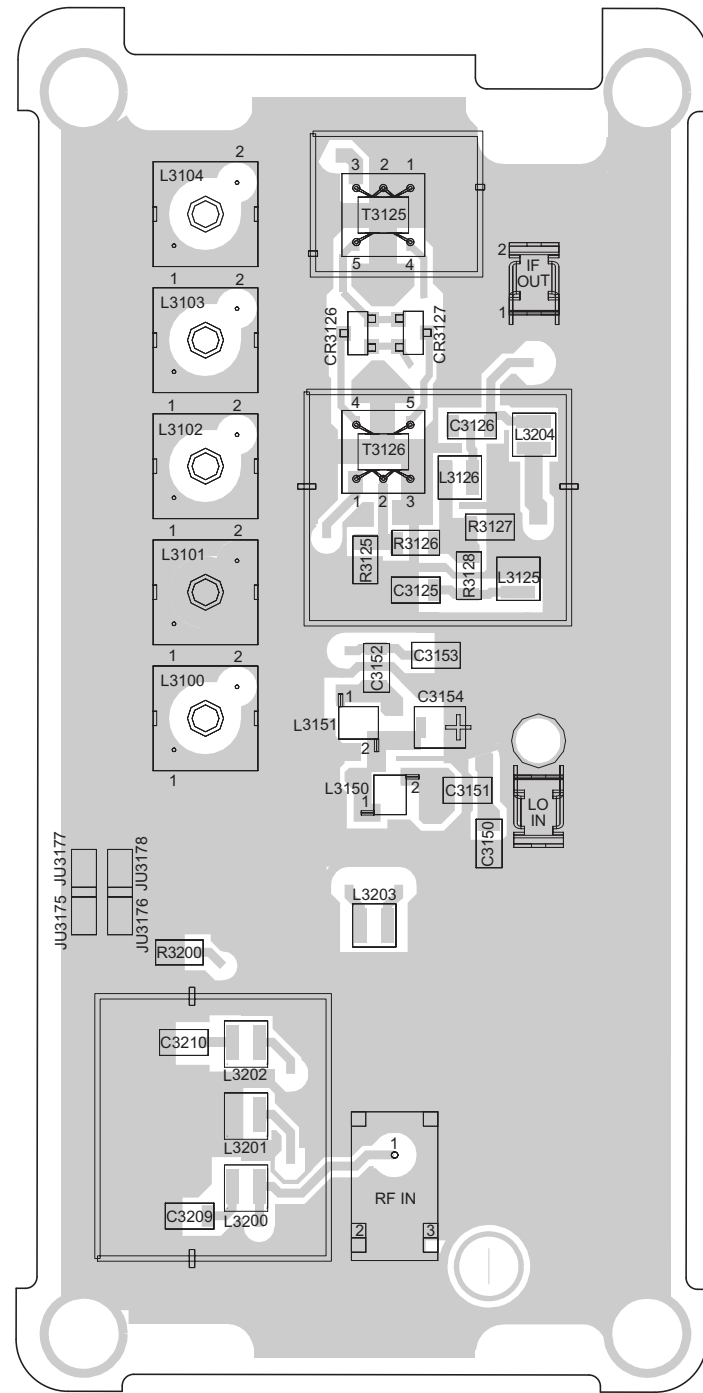

Side 1

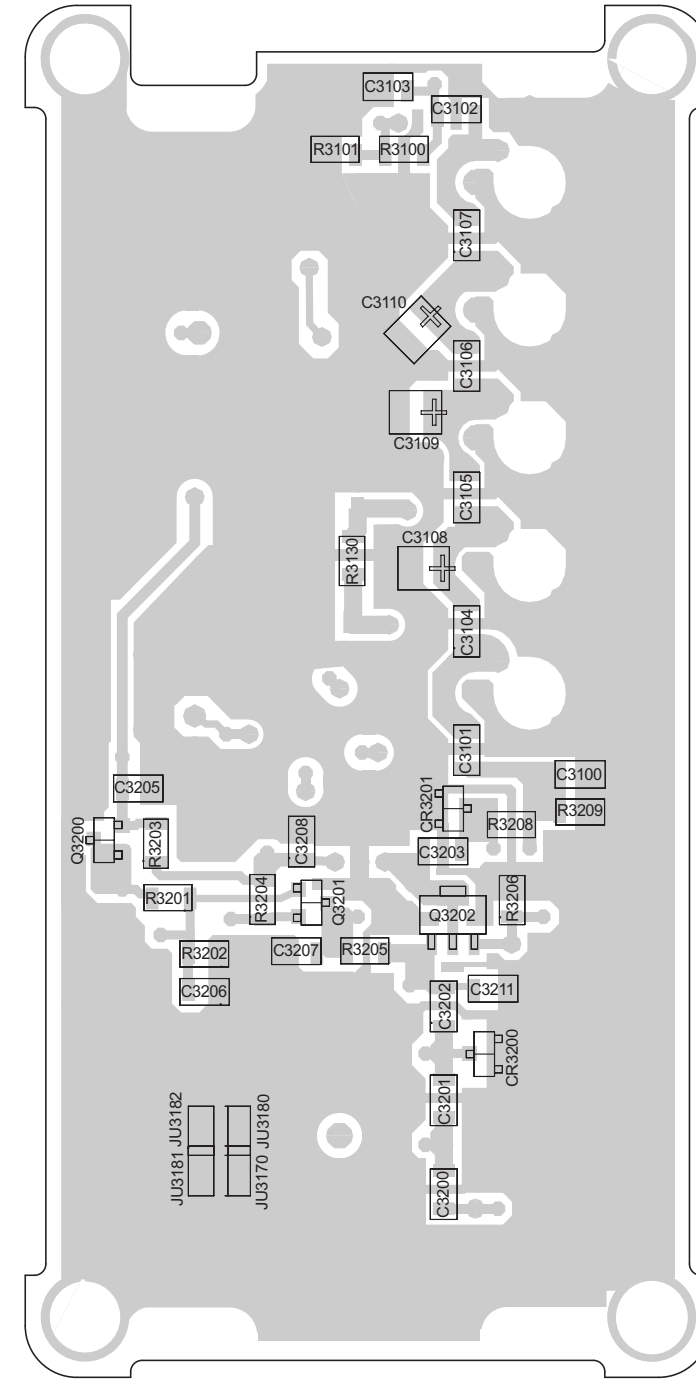

Side 2

HRD6001E/6002E/6011E/6012E VHF Component Location Diagram

HRD6001E VHF RXFE Parts List

ITEM	MOTOROLA PART NUMBER	DESCRIPTION
C3100 & C3101	2113740B34	CAP CHIP REEL CL1 +/-30 24
C3102	2113740B30	CAP CHIP REEL CL1 +/-30 16
C3103	2113740B34	CAP CHIP REEL CL1 +/-30 24
C3104	2113740B11	CAP CHIP REEL CL1 +/-30 2.7
C3105 & C3106	2113740B09	CAP CHIP REEL CL1 +/-30 2.2
C3107	2113740B11	CAP CHIP REEL CL1 +/-30 2.7
C3108 thru C3110	2111078B15	CAP CHIP RF 12 5 NPO 100V
C3125	2113740B29	CAP CHIP REEL CL1 +/-30 15
C3126	2113740B35	CAP CHIP REEL CL1 +/-30 27
C3150 thru C3153	2113740B27	CAP CHIP REEL CL1 +/-30 12
C3154	2111078B25	CAP CHIP RF 27 5 NPO 100V
C3200	2113740B30	CAP CHIP REEL CL1 +/-30 16
C3201	2113740B24	CAP CHIP REEL CL1 +/-30 9.1
C3202 & C3203	2113740B49	CAP CHIP REEL CL1 +/-30 100
C3205 thru C3208	2113741N45	CAP CHIP CL2 X7R 10% 10000
C3209 & C3210	0611077A01	RES CHIP JUMPER
CR3125	4880236E17	DIODE QUAD RING
CR3200 & CR3201	4880154K03	DIODE DUAL SCHOTTKY MIXER
E3103 & E3104	2980014A03	CLIP COAX TERMINAL
E3105 & E3106	2680003M03	SHLD HI IF TIN PLATED
E3107	2680004M03	SHLD OUTPUT MATCH TIN PLATED
J3102	0980110M01	RECP COAX PCB MOUNT
JU3175 & JU3178	0611077A01	RES CHIP JUMPER
JU3180 & JU3181	0611077A01	RES CHIP JUMPER
L3100 thru L3104	2480148M07	IND 4 1/2 TURNS FER CORE 82NH
L3125 & L3126	2480140E06	INDUCTOR CHIP 130 NH
L3150 & L3151	2480091G23	COIL AIRWOUND
L3200	2480140E04	INDUCTOR CHIP 65 NH
L3201	2480140E03	INDUCTOR CHIP 50 NH
L3202	2480140E04	INDUCTOR CHIP 65 NH
L3203	2480140E07	INDUCTOR CHIP 680 NH
L3204	2480140E01	INDUCTOR CHIP 1.2 UH

ITEM	MOTOROLA PART NUMBER	DESCRIPTION
Q3200 & Q3201	4880141L01	TSTR PNP SOT23 LO PROFILE TAPE
Q3202	4802000P02	NEC SILICON TR 2SC3357 RE
R3100	0611077A26	RES CHIP 10 5 1/8W
R3101 & R3125	0611077A70	RES CHIP 680 5 1/8W
R3126	0611077A26	RES CHIP 10 5 1/8W
R3127	0611077A70	RES CHIP 680 5 1/8W
R3128	0611077A43	RES CHIP 51 5 1/8W
R3130	0611077A01	RES CHIP JUMPER
R3200	0611077A43	RES CHIP 51 5 1/8W
R3201	0611077A98	RES CHIP 10K 5 1/8W
R3202	0611077B15	RES CHIP 47K 5 1/8W
R3203	0611077A43	RES CHIP 51 5 1/8W
R3204	0611077A01	RES CHIP JUMPER
R3205	0611077A98	RES CHIP 10K 5 1/8W
R3206	0611077A46	RES CHIP 68 5 1/8W
R3208	0611077A26	RES CHIP 10 5 1/8W
R3209	0611077A72	RES CHIP 820 5 1/8W
T3125	2405548Q06	TRANSFORMER, RF
T3126	2405548Q06	TRANSFORMER, RF
W3101	3080037R05	CABLE ASSEMBLY
W3103	3080152M07	CBL COAX ASSEMBLY
	1280954T42	SPECTRA VHF FRONT END ASSEM
	MXW7635	HRD6001B/6011B PL
	8480067S32	PCB VHF RX PNL
	5480072G01	LABEL BD CKT PRD

HRD6002E Parts List

ITEM	MOTOROLA PART NUMBER	DESCRIPTION
C3100	2113740B31	CAP CHIP REEL CL1 +/-30 18
C3101	2113740B35	CAP CHIP REEL CL1 +/-30 27
C3102	2113740B31	CAP CHIP REEL CL1 +/-30 18
C3103	2113740B35	CAP CHIP REEL CL1 +/-30 27
C3104	211374B009	CAP CHIP REEL CL1 +/-30 2.2 ³
	2113740B11	CAP CHIP REEL CL1 +/-30 2.7
C3105 thru C3106	2113740B11	CAP CHIP REEL CL1 +/-30 2.7
C3107	2113740B13	CAP CHIP REEL CL1 +/-30 3.3
C3108	2111078B16	CAP CHIP RF 13 5 NPO 100V ³
	2111078B19	CAP CHIP RF 16 5 NPO 100V
C3109 & C3110	2111078B16	CAP CHIP RF 13 5 NPO 100V
C3125	2113740B29	CAP CHIP REEL CL1 +/-30 15
C3126	2113740B35	CAP CHIP REEL CL1 +/-30 27
C3150 thru C3153	2113740B27	CAP CHIP REEL CL1 +/-30 12
C3154	2111078B25	CAP CHIP RF 27 5 NPO 100V
C3200	2113740B25	CAP CHIP REEL CL1 +/-30 10 ³
	2113740B30	CAP CHIP REEL CL1 +/-30 16
C3201	2113740B23	CAP CHIP REEL CL1 +/-30 8.2 ³
	2113740B24	CAP CHIP REEL CL1 +/-30 9.1
C3202	2113740B49	CAP CHIP REEL CL1 +/-30 100
	2113740B65	CAP CHIP REEL CL1 +/-30 470 ³
C3203	2113740B49	CAP CHIP REEL CL1 +/-30 100
C3205 thru C3208	2113741N45	CAP CHIP CL2 X7R 10% 10000
C3209	2113740B31	CAP CHIP REEL CL1 +/-30 18 ³
C3210	2113740B32	CAP CHIP REEL CL1 +/-30 20 ³
CR3125	4880236E17	DIODE QUAD RING ¹
CR3126 & C3127	4880154K03	DIODE DUAL SCHOTTKY MIXER ⁴
CR3200 & CR3201	4880154K03	DIODE DUAL SCHOTTKY MIXER ⁴
E3103 & E3104	2980014A03	CLIP COAX TERMINAL ⁶
E3105 & E3106	2680003M03	SHLD HI IF TIN PLATED ⁶
E3107	2680004M03	SHLD OUTPUT MATCH TIN PLATED ⁶

ITEM	MOTOROLA PART NUMBER	DESCRIPTION
J3102	0980110M01	RECP COAX PCB MOUNT
JU3175	0611077A01	RES CHIP JUMPER ³
JU3177 & JU3178	-----	NOTPLACED
JU3176, JU3179, & JU3181 ³	0611077A01	RES CHIP JUMPER
JU3180 & JU3181	-----	NOTPLACED ³
JU3182	0611077A01	RES CHIP JUMPER ³
JU3209 & JU3210	0611077A01	RES CHIP JUMPER ²
L3100 thru L3104	2480148M04	IND 3 1/2 TURNS FER CORE 62NH
L3125 & L3126	2480140E06	INDUCTOR CHIP 130 NH
L3150 & L3151	2480091G23	COIL AIRWOUND
L3200	2480140E04	INDUCTOR CHIP 65 NH
	2480140E06	INDUCTOR CHIP 130 NH ³
L3201	2480140E03	INDUCTOR CHIP 50 NH
L3202	2480140E04	INDUCTOR CHIP 65 NH
	2480140E06	INDUCTOR CHIP 130 NH ³
L3203	2480140E07	INDUCTOR CHIP 680 NH
	2480140E06	INDUCTOR CHIP 130 NH ³
L3204	2480140E01	INDUCTOR CHIP 1.2 UH
M3000 & M3001	2980014A03	CLIP COAX TERMINAL ³
Q3200	4880141L01	TSTR PNP SOT23 LO PROFILE TAPE
Q3201	4880141L01	TSTR PNP SOT23 LO PROFILE TAPE
Q3202	4882971R01	TSTR NPN 71R01 RF
	4802000P02	NEC SILICON TR 2SC3357 RE ⁷
R3100	0611077A26	RES CHIP 10 5 1/8W
R3101	0611077A70	RES CHIP 680 5 1/8W
R3125	0611077A70	RES CHIP 680 5 1/8W
	0611077A68	RES CHIP 560 5 1/8W ³
R3126	0611077A26	RES CHIP 10 5 1/8W
R3127	0611077A70	RES CHIP 680 5 1/8W
	0611077A68	RES CHIP 560 5 1/8W ³
R3128	0611077A43	RES CHIP 51 5 1/8W
R3130	0611077A01	RES CHIP JUMPER
R3131 & R3132	-----	NOTPLACED ³
R3200	0611077A43	RES CHIP 51 5 1/8W
R3201	0611077A98	RES CHIP 10K 5 1/8W
R3202	0611077B15	RES CHIP 47K 5 1/8W
R3203	0611077A43	RES CHIP 51 5 1/8W
R3204	0611077A01	RES CHIP JUMPER
R3205	0611077A98	RES CHIP 10K 5 1/8W
R3206	0611077A36	RES CHIP 27 5 1/8W ⁵

ITEM	MOTOROLA PART NUMBER	DESCRIPTION
R3208	0611077A26 0611077A32	RES CHIP 10 5 1/8W RES CHIP 18 5 1/8W ¹
R3209	0611077A68 0611077A72	RES CHIP 560 5 1/8W RES CHIP 820 5 1/8W ⁴
R3210	0611077A68 0611077A72	RES CHIP 560 5 1/8W ⁴ RES CHIP 820 5 1/8W ³
SH1	2680003M03	SHLD HI IF TIN PLATED ³
SH2	2680004M03	SHLD OUTPUT MATCH TIN PLATED ³
SH3	2680003M03	SHLD HI IF TIN PLATED ³
T3125	2405548Q06	TRANSFORMER, RF ⁶
T3126	2405548Q06	TRANSFORMER, RF
T3127	2405548Q06	TRANSFORMER, RF ³
W3101	3080037R05	CABLE ASSEMBLY ⁶
W3103	3080152M07	CBL COAX ASSEMBLY ⁶
	1280954T42	SPECTRA VHF FRONT END ASSEM

- Notes:
 1. Valid in HRD6002C only.
 2. Valid in HRD6002E only.
 3. Valid in HRD6002G only.
 4. Not valid in HRD6002C.
 5. Not valid in HRD6002E
 6. Not valid in HRD6002G
 7. Valid in HRD6002E and HRD6002G only.

HRD6011E Parts List

ITEM	MOTOROLA PART NUMBER	DESCRIPTION
C3100 & C3101	2113740B34	CAP CHIP REEL CL1 +/-30 24
C3102	2113740B30	CAP CHIP REEL CL1 +/-30 16
C3103	2113740B34	CAP CHIP REEL CL1 +/-30 24
C3104	2113740B11	CAP CHIP REEL CL1 +/-30 2.7
C3105 & C3106	2113740B09	CAP CHIP REEL CL1 +/-30 2.2
C3107	2113740B11	CAP CHIP REEL CL1 +/-30 2.7
C3108	2111078B16	CAP CHIP RF 13 5 NPO 100V
C3109	2111078B15	CAP CHIP RF 12 5 NPO 100V
C3110	2111078B16	CAP CHIP RF 13 5 NPO 100V
C3125	2113740B29	CAP CHIP REEL CL1 +/-30 15
C3126	2113740B35	CAP CHIP REEL CL1 +/-30 27
C3150 thru C3153	2113740B27	CAP CHIP REEL CL1 +/-30 12
C3154	2111078B25	CAP CHIP RF 27 5 NPO 100V
C3200	2113740B30	CAP CHIP REEL CL1 +/-30 16
C3201	2113740B24	CAP CHIP REEL CL1 +/-30 9.1

ITEM	MOTOROLA PART NUMBER	DESCRIPTION
C3202 & C3203	2113740B49	CAP CHIP REEL CL1 +/-30 100
C3205 thru C3208	2113741N45	CAP CHIP CL2 X7R 10% 10000
C3209 & C3210	0611077A01	RES CHIP JUMPER ¹
CR3125	4880236E17	DIODE QUAD RING
CR3200	4880154K03	DIODE DUAL SCHOTTKY MIXER ¹
CR3201	4880154K03	DIODE DUAL SCHOTTKY MIXER ¹
E3103 & E3104	2980014A03	CLIP COAX TERMINAL
E3105 & E3106	2680003M03	SHLD HI IF TIN PLATED
E3107	2680004M03	SHLD OUTPUT MATCH TIN PLATED
J3102	0980110M01	RECP COAX PCB MOUNT
JU3177 & JU3178	0611077A01	RES CHIP JUMPER
JU3180 & JU3182	0611077A01	RES CHIP JUMPER
L3100 thru L3104	2480148M07	IND 4 1/2 TURNS FER CORE 82NH
L3125 & L3126	2480140E06	INDUCTOR CHIP 130 NH
L3150 & L3151	2480091G23	COIL AIRWOUND
L3200	2480140E04	INDUCTOR CHIP 65 NH
L3201	2480140E03	INDUCTOR CHIP 50 NH
L3202	2480140E04	INDUCTOR CHIP 65 NH
L3203	2480140E07	INDUCTOR CHIP 680 NH
L3204	2480140E01	INDUCTOR CHIP 1.2 UH
Q3200 & Q3201	4880141L01	TSTR PNP SOT23 LO PROFILE TAPE
Q3202	4882971R01	TSTR NPN 71R01 RF
R3100 & R3126	0611077A01	RES CHIP JUMPER
R3128	0611077A43	RES CHIP 51 5 1/8W
R3130	0611077A01	RES CHIP JUMPER
R3201	0611077A98	RES CHIP 10K 5 1/8W
R3202	0611077B15	RES CHIP 47K 5 1/8W
R3203	0611077A43	RES CHIP 51 5 1/8W
R3204	0611077A01	RES CHIP JUMPER
R3205	0611077A98	RES CHIP 10K 5 1/8W
R3206 & R3208	0611077A26	RES CHIP 10 5 1/8W
R3209	0611077A72	RES CHIP 820 5 1/8W
R3210	0611077A72	RES CHIP 820 5 1/8W ²
T3125	2405548Q06	TRANSFORMER, RF
T3126	2405548Q06	TRANSFORMER, RF
W3101	3080037R05	CABLE ASSEMBLY

ITEM	MOTOROLA PART NUMBER	DESCRIPTION
W3103	3080152M07	CBL COAX ASSEMBLY
	1280954T42	SPECTRA VHF FRONT END ASSEM

- Notes:
 1. Valid in HRD6011D only.
 2. Valid in HRD6011C only.

HRD6012E Parts List

ITEM	MOTOROLA PART NUMBER	DESCRIPTION
C3100	2113740B31	CAP CHIP REEL CL1 +/-30 18
C3101	2113740B35	CAP CHIP REEL CL1 +/-30 27
C3102	2113740B31	CAP CHIP REEL CL1 +/-30 18
C3103	2113740B35	CAP CHIP REEL CL1 +/-30 27
C3104	2113740B09	CAP CHIP REEL CL1 +/-30 2.2 ³
	2113740B11	CAP CHIP REEL CL1 +/-30 2.7
C3105 thru C3106	2113740B11	CAP CHIP REEL CL1 +/-30 2.7
C3107	2113740B13	CAP CHIP REEL CL1 +/-30 3.3
C3108	2111078B16	CAP CHIP RF 13 5 NPO 100V ³
	2111078B19	CAP CHIP RF 16 5 NPO 100V
C3109 & C3110	2111078B16	CAP CHIP RF 13 5 NPO 100V
C3125	2113740B29	CAP CHIP REEL CL1 +/-30 15
C3126	2113740B35	CAP CHIP REEL CL1 +/-30 27
C3150 thru C3153	2113740B27	CAP CHIP REEL CL1 +/-30 12
C3154	2111078B25	CAP CHIP RF 27 5 NPO 100V
C3200	2113740B25	CAP CHIP REEL CL1 +/-30 10 ³
	2113740B30	CAP CHIP REEL CL1 +/-30 16
C3201	2113740B24	CAP CHIP REEL CL1 +/-30 9.1
	2113740B25	CAP CHIP REEL CL1 +/-30 10 ³
C3202	2113740B49	CAP CHIP REEL CL1 +/-30 100
	2113740B65	CAP CHIP REEL CL1 +/-30 470 ³
C3203	2113740B49	CAP CHIP REEL CL1 +/-30 100
C3205 thru C3208	2113741N45	CAP CHIP CL2 X7R 10% 10000
C3209	0611077A01 2113740B31	RES CHIP JUMPER CAP CHIP REEL CL1 +/-30 18 ³

ITEM	MOTOROLA PART NUMBER	DESCRIPTION
C3210	0611077A01 2113740B32	RES CHIP JUMPER CAP CHIP REEL CL1 +/-30 20 ³
CR3125	4880236E17	DIODE QUAD RING ¹
CR3126 & CR3127	4880154K03	DIODE DUAL SCHOTTKY MIXER ⁴
CR3200 & CR3201	4880154K03	DIODE DUAL SCHOTTKY MIXER
E3103 & E3104	2980014A03	CLIP COAX TERMINAL ⁵
E3105 & E3106	2680003M03	SHLD HI IF TIN PLATED ⁵
E3107	2680004M03	SHLD OUTPUT MATCH TIN PLATED ⁵
J3102	0980110M01	RECP COAX PCB MOUNT
JU3175	-----	NOTPLACED ³
JU3176 & JU3177	0611077A01	RES CHIP JUMPER
JU3178	-----	NOTPLACED ³
JU3179	0611077A01	RES CHIP JUMPER
JU3180	-----	NOTPLACED ³
JU3181	0611077A01	RES CHIP JUMPER ³
JU3182	0611077A01 -----	RES CHIP JUMPER NOTPLACED ³
L3100 thru L3104	2480148M04	IND 3 1/2 TURNS FER CORE 62NH
L3125 & L3126	2480140E06	INDUCTOR CHIP 130 NH
L3150 & L3151	2480091G23	COIL AIRWOUND
L3200	2480140E04 2480140E06	INDUCTOR CHIP 65 NH INDUCTOR CHIP 130 NH ³
L3201	2480140E03	INDUCTOR CHIP 50 NH
L3202	2480140E04 2480140E06	INDUCTOR CHIP 65 NH INDUCTOR CHIP 130 NH ³
L3203	2480140E06 2480140E07	INDUCTOR CHIP 130 NH ³ INDUCTOR CHIP 680 NH
L3204	2480140E01	INDUCTOR CHIP 1.2 UH
M3000 & M3001	2980014A03	CLIP COAX TERMINAL ³
Q3200 & Q3201	4880141L01	TSTR PNP SOT23 LO PROFILE TAPE
Q3202	4880141L01	TSTR PNP SOT23 LO PROFILE TAPE ²
	4802000P02	NEC SILICON TR 2SC3357 RE ³
	4882971R01	TSTR NPN 71R01 RF ¹
R3101, R31127 & R3125	-----	NOTPLACED ³
R3100 & R3126	0611077A01	RES CHIP JUMPER
R3128	0611077A43	RES CHIP 51 5 1/8W

ITEM	MOTOROLA PART NUMBER	DESCRIPTION
R3130	0611077A01	RES CHIP JUMPER
R3131 & R3132	-----	NOTPLACED ³
R3200	-----	NOTPLACED ³
R3201	0611077A98	RES CHIP 10K 5 1/8W
R3202	0611077B15	RES CHIP 47K 5 1/8W
R3203	0611077A43	RES CHIP 51 5 1/8W
R3204	0611077A01	RES CHIP JUMPER
R3205	0611077A98	RES CHIP 10K 5 1/8W
R3206	0611077A10 0611077A26	RES CHIP 2.2 5 1/8W ³ RES CHIP 10 5 1/8W
R3208	0611077A26	RES CHIP 10 5 1/8W
R3209	0611077A72	RES CHIP 820 5 1/8W
R3210	-----	NOTPLACED ³
SH1	2680003M03	SHLD HI IF TIN PLATED ³
SH2	2680004M03	SHLD OUTPUT MATCH TIN PLATED ³
SH3	2680003M03	SHLD HI IF TIN PLATED ³
T3125	2405548Q06	TRANSFORMER, RF ⁵
T3126	2405548Q06	TRANSFORMER, RF
T3127	2405548Q06	TRANSFORMER, RF ³
W3101	3080037R05	CABLE ASSEMBLY ⁵
W3103	3080152M07	CBL COAX ASSEMBLY ⁵
	8480067S02	PCB VHF RX ¹
	8480067S32	PCB VHF RX PNL ²
	1280954T42	SPECTRA VHF FRONT END ASSEM

Notes:

1. Valid in HRD6012D only.
2. Valid in HRD6012E only.
3. Valid in HRD6012G only.
4. Not valid in HRD6012D.
5. Noy valid in HRD6012G.

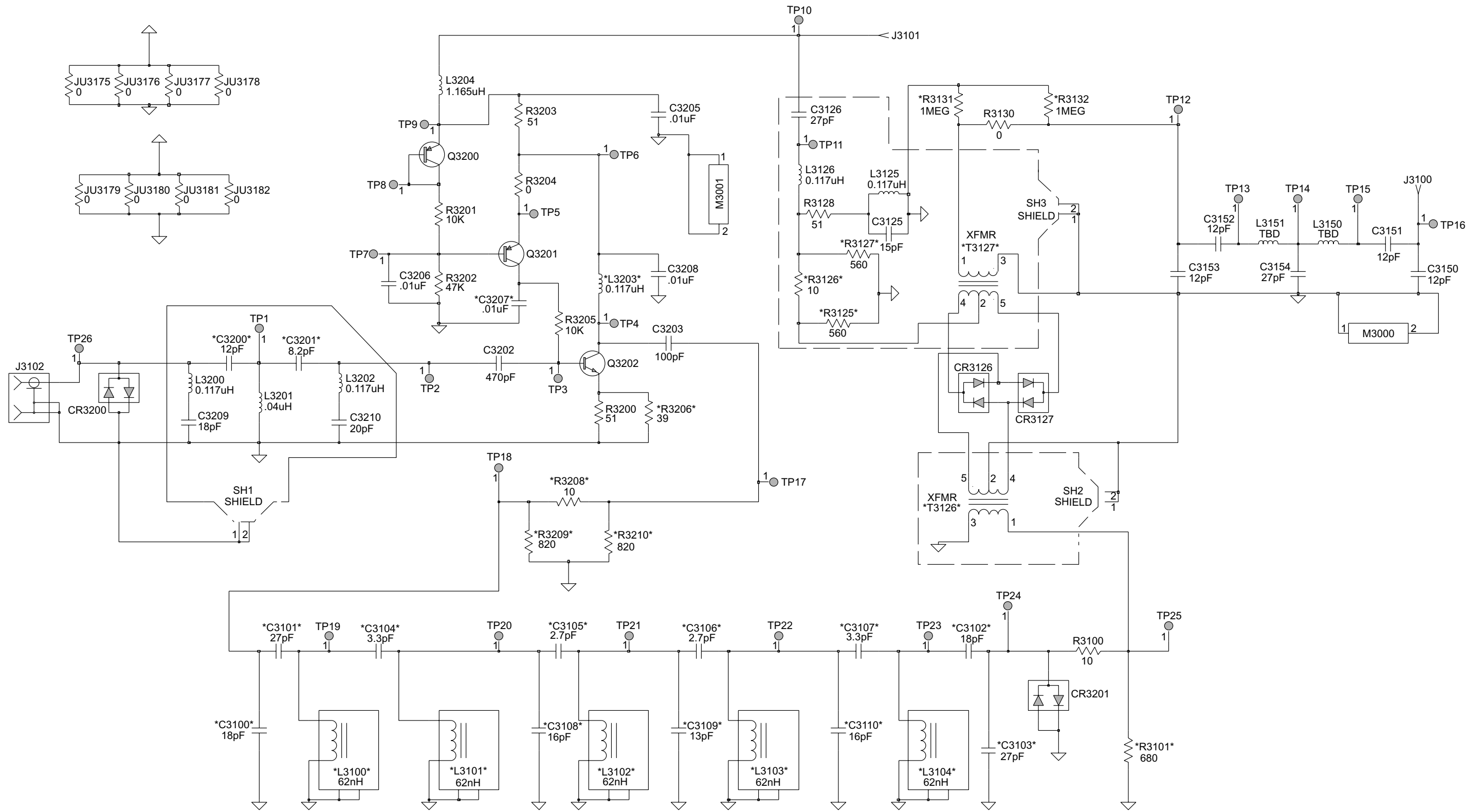

HRD6001G/6002G/6011G/6012G VHF Receiver Front-End Schematic

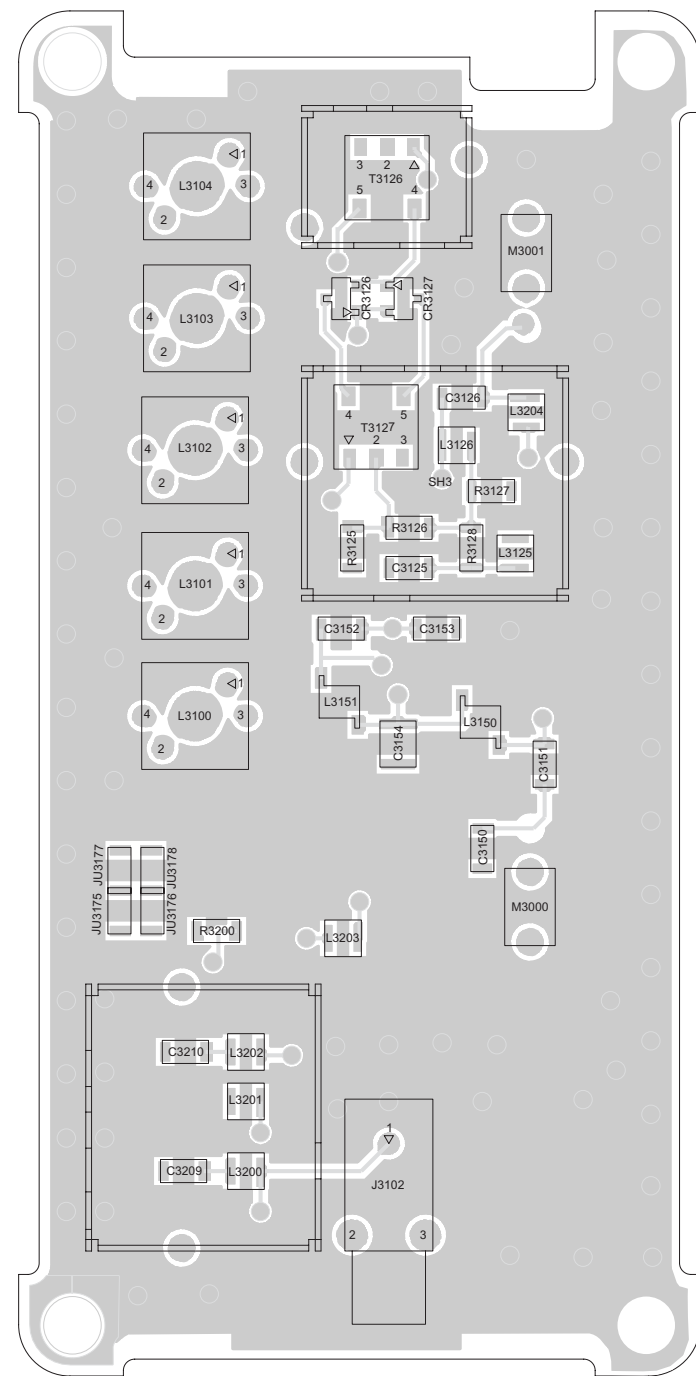

Side 1

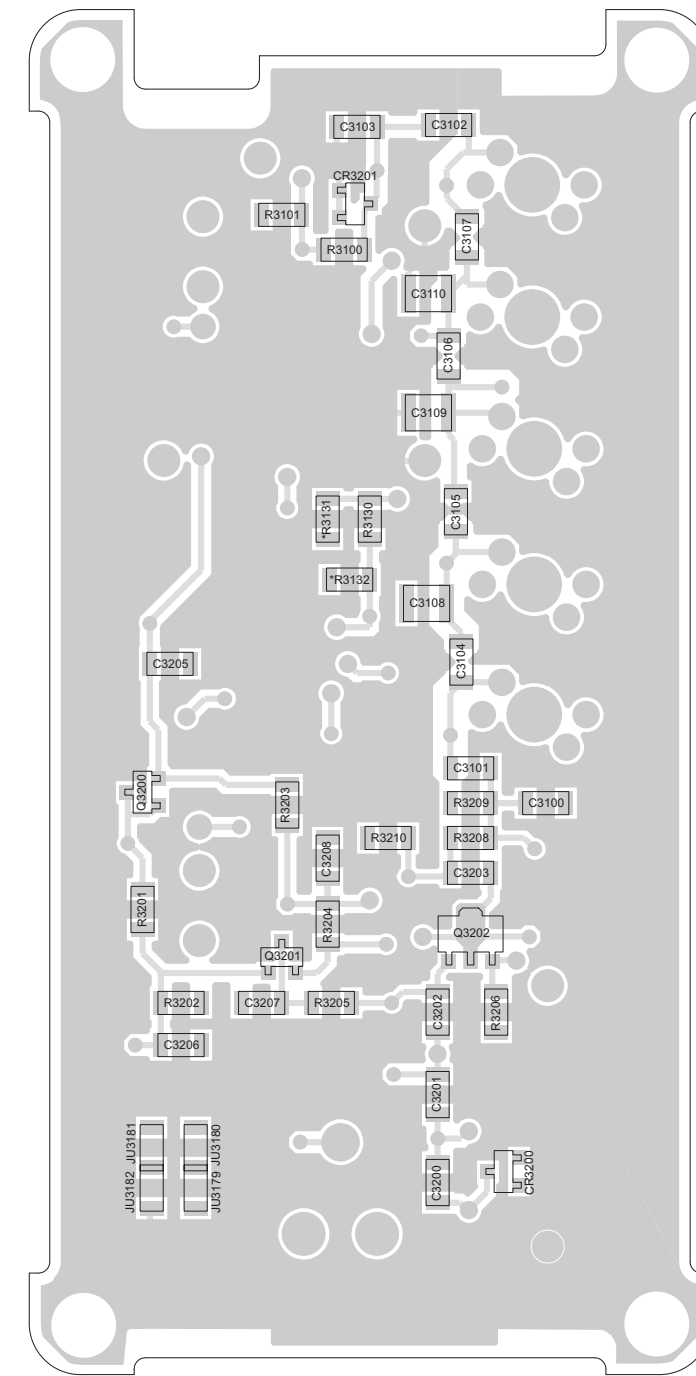

Side 2

HRD6001G/6002G/6011G/6012G VHF Receiver Front-End Component Location Diagram

HRD6001G/HRD6002G/HRD6011G/HRD6012G VHF RXFE
Parts List

ITEM	MOTOROLA PART NUMBER	DESCRIPTION
C3100	2113740B35 ¹ 2113740B31 ² 2113740B35 ³ 2113740B31 ⁴	CAP CHIP REEL CL1 +/-30 27
C3101	2113740B32 ¹ 2113740B35 ² 2113740B32 ³ 2113740B35 ⁴	CAP CHIP REEL CL1 +/-30 20
C3102	2113740B32 ¹ 2113740B31 ² 2113740B34 ³ 2113740B31 ⁴	CAP CHIP REEL CL1 +/-30 20
C3103	2113740B31 ¹ 2113740B35 ² 2113740B31 ³ 2113740B35 ⁴	CAP CHIP REEL CL1 +/-30 18
C3104	2113740B13 ¹ 2113740B09 ² 2113740B13 ³ 2113740B09 ⁴	CAP CHIP REEL CL1 +/-30 3.3
C3105 & C3106	2113740B11	CAP CHIP REEL CL1 +/-30 2.7
C3107	2113740B11 ¹ 2113740B13 ² 2113740B11 ³ 2113740B13 ⁴	CAP CHIP REEL CL1 +/-30 2.7
C3108 & C3109	2111078B15 ¹ 2111078B16 ² 2111078B15 ³ 2111078B16 ⁴	CAP CHIP RF 12 5 NPO 100V
C3110	2111078B15 ¹ 2111078B16 ² 2111078B15 ³ 2111078B16 ⁴	CAP CHIP RF 12 5 NPO 100V
C3125	2113740B29	CAP CHIP REEL CL1 +/-30 15
C3126	2113740B35	CAP CHIP REEL CL1 +/-30 27
C3150 thru C3153	2113740B27	CAP CHIP REEL CL1 +/-30 12
C3154	2111078B25	CAP CHIP RF 27 5 NPO 100V
C3200	2113740B27 ¹ 2113740B25 ² 2113740B27 ³ 2113740B25 ⁴	CAP CHIP REEL CL1 +/-30 12
C3201	2113740B23 ¹ 2113740B23 ² 2113740B23 ³ 2113740B25 ⁴	CAP CHIP REEL CL1 +/-30 8.2
C3202	2113740B65	CAP CHIP REEL CL1 +/-30 470

ITEM	MOTOROLA PART NUMBER	DESCRIPTION
C3203	2113740B49	CAP CHIP REEL CL1 +/-30 100
C3205	2113741N45	CAP CHIP CL2 X7R 10% 10000
C3206	2113741N45	CAP CHIP CL2 X7R 10% 10000
C3207	2113741N45	CAP CHIP CL2 X7R 10% 10000
C3208	2113741N45	CAP CHIP CL2 X7R 10% 10000
C3209	2113740B31	CAP CHIP REEL CL1 +/-30 18
C3210	2113740B32	CAP CHIP REEL CL1 +/-30 20
CR3126 & CR3127	4880154K03	DIODE DUAL SCHOTTKY MIXER
CR3200 & CR3201	4880154K03	DIODE DUAL SCHOTTKY MIXER
J3102	0980110M01	RECP COAX PCB MOUNT
JU3175	0611077A01 ¹ 0611077A01 ² NOTPLACED ³ NOTPLACED ⁴	RES CHIP JUMPER
JU3176	NOTPLACED ¹ 0611077A01 ² NOTPLACED ³ 0611077A01 ⁴	RES CHIP JUMPER
JU3177	NOTPLACED ¹ NOTPLACED ² 0611077A01 ³ 0611077A01 ⁴	RES CHIP JUMPER
JU3178	0611077A01 ¹ NOTPLACED ² 0611077A01 ³ NOTPLACED ⁴	RES CHIP JUMPER
JU3179	NOTPLACED ¹ 0611077A01 ² NOTPLACED ³ 0611077A01 ⁴	RES CHIP JUMPER
JU3180	0611077A01 ¹ NOTPLACED ² 0611077A01 ³ NOTPLACED ⁴	RES CHIP JUMPER
JU3181	NOTPLACED ¹ NOTPLACED ² 0611077A01 ³ 0611077A01 ⁴	RES CHIP JUMPER
JU3182	0611077A01 ¹ 0611077A01 ² NOTPLACED ³ NOTPLACED ⁴	RES CHIP JUMPER
L3100 thru L3104	2480148M04	IND 3 1/2 TURNS FER CORE 62NH

ITEM	MOTOROLA PART NUMBER	DESCRIPTION
L3125 & L3126	2480140E06	INDUCTOR CHIP 130 NH
L3150 & L3151	2480091G23	COIL AIRWOUND
L3200	2480140E06	INDUCTOR CHIP 130 NH
L3201	2480140E03	INDUCTOR CHIP 50 NH
L3202 & L3203	2480140E06	INDUCTOR CHIP 130 NH
L3204	2480140E01	INDUCTOR CHIP 1.2 UH
M3000	2980014A03	CLIP COAX TERMINAL
M3001	2980014A03	CLIP COAX TERMINAL
Q3200	4880141L01	TSTR PNP SOT23 LO PROFILE TAPE
Q3201	4880141L01	TSTR PNP SOT23 LO PROFILE TAPE
Q3202	4802000P02	NEC SILICON TR 2SC3357 RE
R3100	0611077A26 ¹ 0611077A26 ² 0611077A01 ³ 0611077A01 ⁴	RES CHIP 10 5 1/8W
R3101	0611077A70 ¹ 0611077A70 ² NOTPLACED ³ NOTPLACED ⁴	RES CHIP 680 5 1/8W
R3125	0611077A68 ¹ 0611077A68 ² NOTPLACED ³ NOTPLACED ⁴	RES CHIP 560 5 1/8W
R3126	0611077A26 ¹ 0611077A26 ² 0611077A01 ³ 0611077A01 ⁴	RES CHIP 10 5 1/8W
R3127	0611077A68 ¹ 0611077A68 ² NOTPLACED ³ NOTPLACED ⁴	RES CHIP 560 5 1/8W
R3128	0611077A43	RES CHIP 51 5 1/8W
R3130	0611077A01	RES CHIP JUMPER
R3131 & R3132	NOTPLACED	-----
R3200	0611077A43 ¹ 0611077A43 ² NOTPLACED ³ NOTPLACED ⁴	RES CHIP 51 5 1/8W
R3201	0611077A98	RES CHIP 10K 5 1/8W
R3202	0611077B15	RES CHIP 47K 5 1/8W
R3203	0611077A43	RES CHIP 51 5 1/8W
R3204	0611077A01	RES CHIP JUMPER
R3205	0611077A98	RES CHIP 10K 5 1/8W
R3206	0611077A36 ¹ 0611077A36 ² 0611077A10 ³ 0611077A10 ⁴	RES CHIP 27 5 1/8W

ITEM	MOTOROLA PART NUMBER	DESCRIPTION
R3208	0611077A26	RES CHIP 10 5 1/8W
R3209	0611077A72	RES CHIP 820 5 1/8W
R3210	0611077A72 ¹ 0611077A72 ² NOTPLACED ³ NOTPLACED ⁴	RES CHIP 820 5 1/8W
SH1	2680003M03	SHLD HI IF TIN PLATED
SH2	2680004M03	SHLD OUTPUT MATCH TIN PLATED
SH3	2680003M03	SHLD HI IF TIN PLATED
T3126 & T3127	2405548Q06	TRANSFORMER, RF

Notes:

1. Valid in HRD6001G.
2. Valid in HRD6002G.
3. Valid in HRD6011G.
4. Valid in HRD6012G.

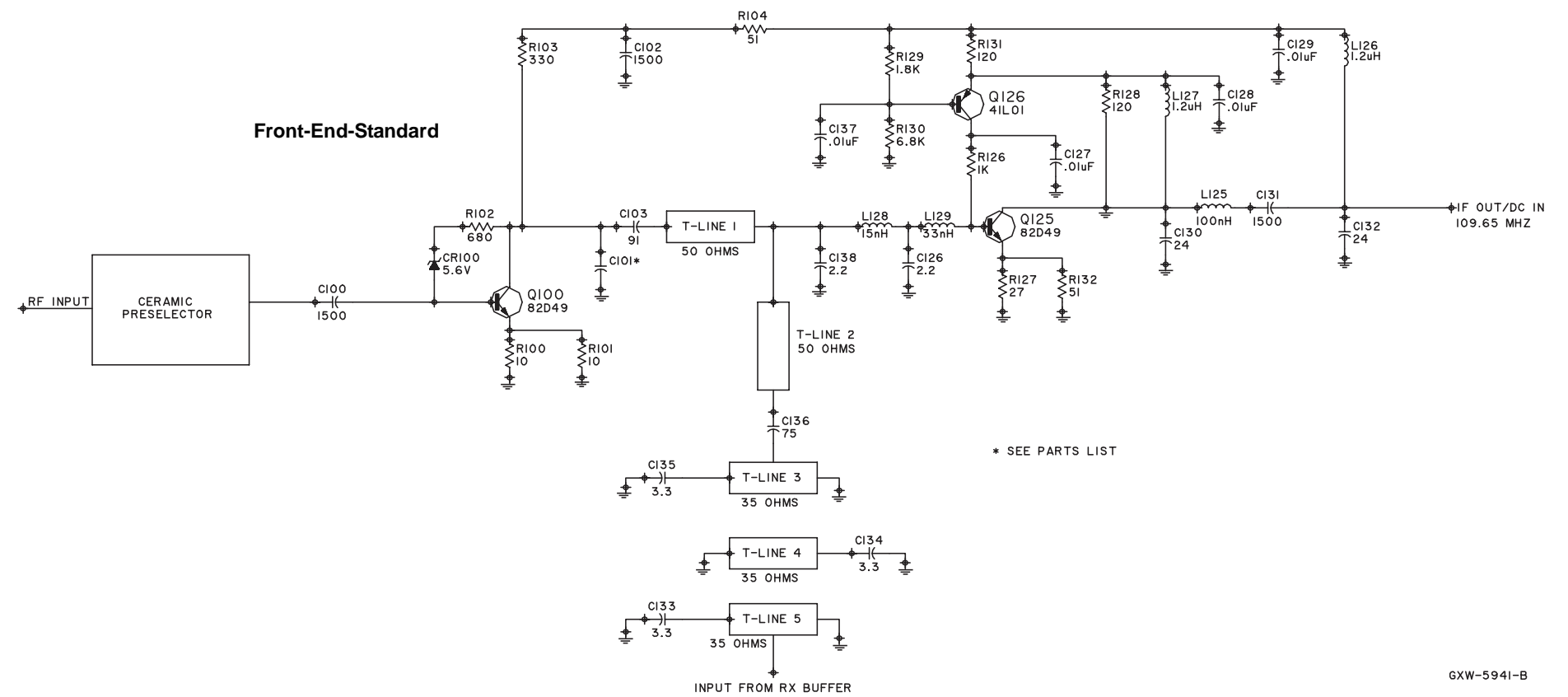
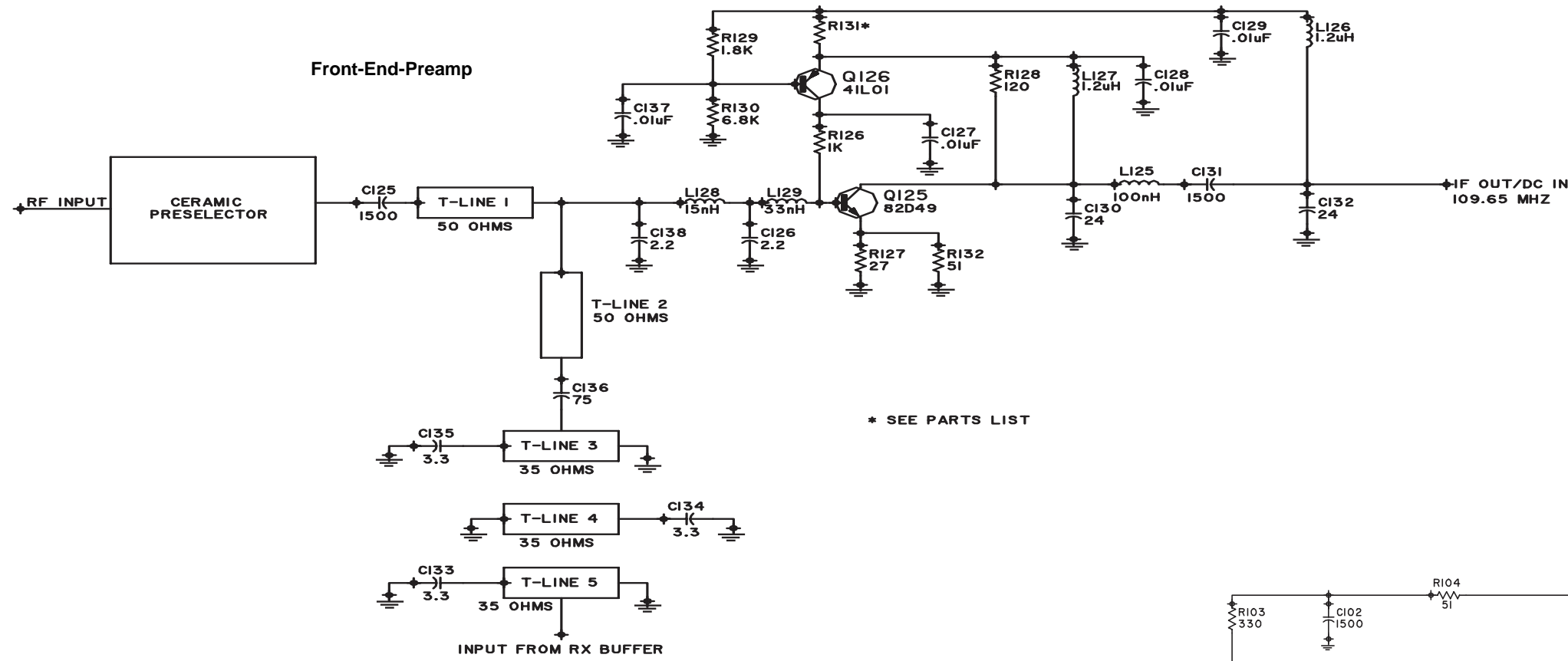

HRE6001B/6002C/6003B/6004B/6011B/6012B/6014B UHF Receiver Front-End Preamp and Standard Schematics

GXW-5941-B

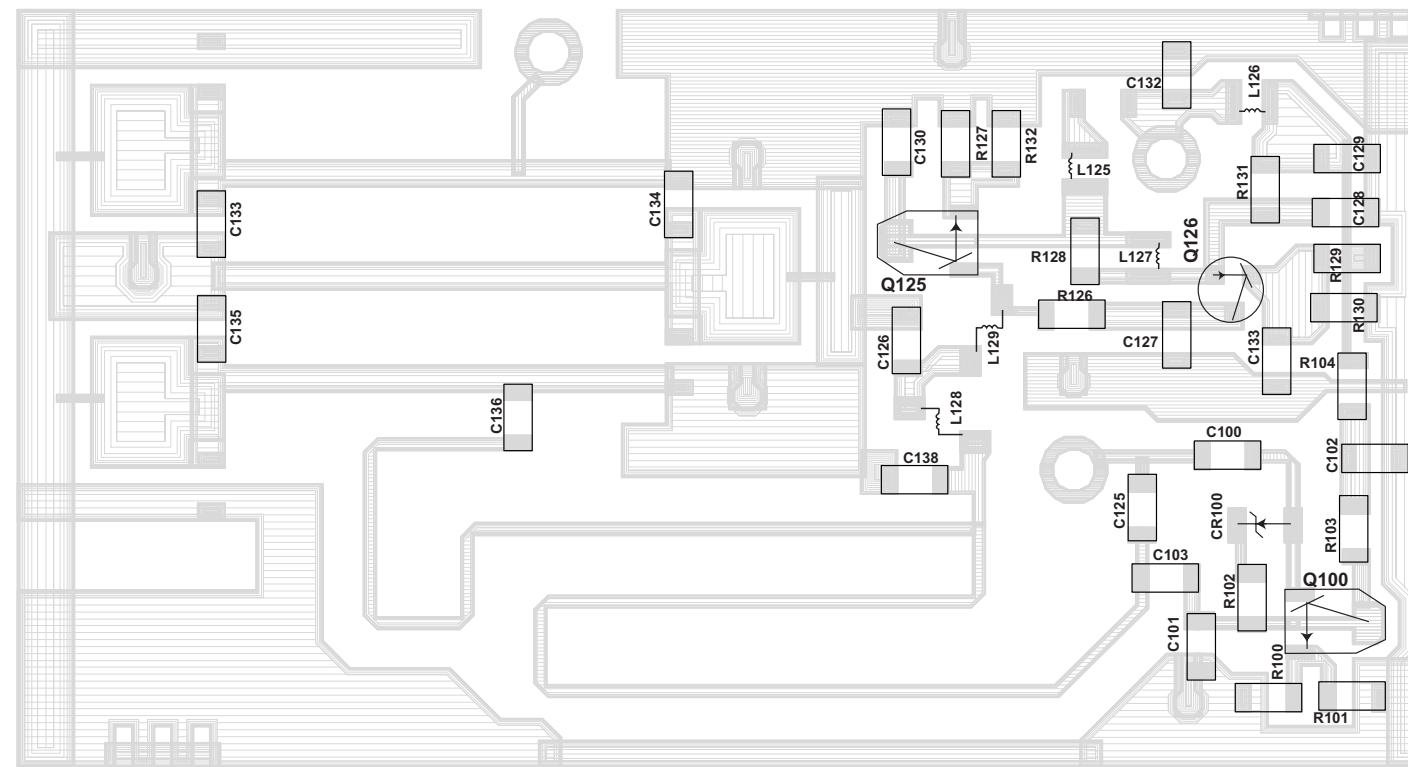

HRE6001B/6002C/6003B/6004B/6011B/6012B/6014B UHF Receiver Front-End Hybrid Component Location Diagram

HRE6011B UHF RXFE Pre-Amp Parts List

ITEM	MOTOROLA PART NUMBER	DESCRIPTION
C100	2113740B76	CAP CHIP REEL CL1 +/-30 1500
C101	2113740B19	CAP CHIP REEL CL1 +/-30 5.6
C102	2113740B76	CAP CHIP REEL CL1 +/-30 1500
C103	2113740B48	CAP CHIP REEL CL1 +/-30 91
C126	2113740B11	CAP CHIP REEL CL1 +/-30 2.7
C127 thru C129	2113741N45	CAP CHIP CL2 X7R 10% 10000
C130	2113740B34	CAP CHIP REEL CL1 +/-30 24
C131	2113740B76	CAP CHIP REEL CL1 +/-30 1500
C132	2113740B34	CAP CHIP REEL CL1 +/-30 24
C133 thru C135	2113740B17	CAP CHIP REEL CL1 +/-30 4.7
C136	2113740B46	CAP CHIP REEL CL1 +/-30 75
C137	2113741N45	CAP CHIP CL2 X7R 10% 10000
C138	2113740B17	CAP CHIP REEL CL1 +/-30 4.7
CR100	4882958R78	DIODE 48R82958R01 A/P 5.6V
E125	2680015P02	SHLD RXFE UHF TIN PLATED
E126	2680002M02	SHLD INJ FLTR TIN PLATED
HY126	9180209N01	FLTR BANDPASS CERAMIC 417 MHZ
JU5125	-----	PART NOT USED
L125	2480140E10	INDUCTOR CHIP 100NH
L126 & L127	2480140E01	INDUCTOR CHIP 1.2 UH
L128	2480091G21	COIL AIRWOUND
L129	2480091G33	COIL AIRWOUND
MP126	0780091P01	BRACKET RX FE UHF
MP127	0780214N01	FRAME PRESELECTOR LEAD
MP128	4280191N01	CLIP RECEIVER GROUNDING
MP129	4280013P01	RETAINER WIRE
MP130	4380025P01	SPACER WIRE
Q100 & Q125	4802000P02	NEC SILICON TR 2SC3357 RE
Q126	4880141L01	TSTR PNP SOT23 LO PROFILE TAPE
R100 & R101	0611077A26	RES CHIP 10 5 1/8W
R102	0611077A70	RES CHIP 680 5 1/8W

ITEM	MOTOROLA PART NUMBER	DESCRIPTION
R103	0611077A62	RES CHIP 330 5 1/8W
R104	0611077A43	RES CHIP 51 5 1/8W
R126	0611077A74	RES CHIP 1000 5 1/8
R127	0611077A36	RES CHIP 27 5 1/8W
R128	0611077A52	RES CHIP 120 5 1/8W
R129	0611077A80	RES CHIP 1800 5 1/8
R130	0611077A94	RES CHIP 6800 5 1/8
R131	0611077A50	RES CHIP 100 5 1/8W
R132	0611077A43	RES CHIP 51 5 1/8W
W128	3080152M07	CBL COAX ASSEMBLY
W642	3080037R05	CABLE ASSEMBLY
	8480241N02	HYBRID CKT BD UHF F/E
	0980212N02	RECP COAX PCB MOUNT

HRE6012B UHF RXFE Pre-Amp Parts List

ITEM	MOTOROLA PART NUMBER	DESCRIPTION
C100	2113740B76	CAP CHIP REEL CL1 +/-30 1500
C101	2113740B19	CAP CHIP REEL CL1 +/-30 5.6
C102	2113740B76	CAP CHIP REEL CL1 +/-30 1500
C103	2113740B48	CAP CHIP REEL CL1 +/-30 91
C126	2113740B09	CAP CHIP REEL CL1 +/-30 2.2
C127 thru C129	2113741N45	CAP CHIP CL2 X7R 10% 10000
C130	2113740B34	CAP CHIP REEL CL1 +/-30 24
C131	2113740B76	CAP CHIP REEL CL1 +/-30 1500
C132	2113740B34	CAP CHIP REEL CL1 +/-30 24
C132	2113740B76	CAP CHIP REEL CL1 +/-30 1500
C133 & C134	2113740B13	CAP CHIP REEL CL1 +/-30 3.3
C135	2113740B13	CAP CHIP REEL CL1 +/-30 3.3
C136	2113740B46	CAP CHIP REEL CL1 +/-30 75
C137	2113741N45	CAP CHIP CL2 X7R 10% 10000
C138	2113740B09	CAP CHIP REEL CL1 +/-30 2.2
CR100	4882958R78	DIODE 48R82958R01 A/P 5.6V
E125	2680015P02	SHLD RXFE UHF TIN PLATED
E126	2680002M02	SHLD INJ FLTR TIN PLATED
HY126	9180209N02	FLTR BANDPASS CERAMIC 455 MHZ
L125	2480140E10	INDUCTOR CHIP 100NH

ITEM	MOTOROLA PART NUMBER	DESCRIPTION
L126 & L127	2480140E01	INDUCTOR CHIP 1.2 UH
L128	2480091G21	COIL AIRWOUND
L129	2480091G33	COIL AIRWOUND
MP126	0780091P01	BRACKET RX FE UHF
MP127	0780214N01	FRAME PRESELECTOR LEAD
MP128	4280191N01	CLIP RECEIVER GROUNDING
MP129	4280013P01	RETAINER WIRE
MP130	4380025P01	SPACER WIRE
Q100 & Q125	4802000P02	NEC SILICON TR 2SC3357 RE
Q126	4880141L01	TSTR PNP SOT23 LO PROFILE TAPE
R100 & R101	0611077A26	RES CHIP 10 5 1/8W
R102	0611077A70	RES CHIP 680 5 1/8W
R103	0611077A62	RES CHIP 330 5 1/8W
R104	0611077A43	RES CHIP 51 5 1/8W
R126	0611077A74	RES CHIP 1000 5 1/8
R127	0611077A36	RES CHIP 27 5 1/8W
R128	0611077A52	RES CHIP 120 5 1/8W
R129	0611077A80	RES CHIP 1800 5 1/8
R130	0611077A94	RES CHIP 6800 5 1/8
R131	0611077A50	RES CHIP 100 5 1/8W
R132	0611077A43	RES CHIP 51 5 1/8W
W128	3080152M07	CBL COAX ASSEMBLY
	0980212N02	RECP COAX PCB MOUNT
	3080037R05	CABLE ASSEMBLY
	0180757T43	SHLD W/CONTACT
	8480241N02	HYBRID CKT BD UHF F/E

HRE6014B UHF RXFE Pre-Amp Parts List

ITEM	MOTOROLA PART NUMBER	DESCRIPTION
C100	2113740B76	CAP CHIP REEL CL1 +/-30 1500
C101	2113740B19	CAP CHIP REEL CL1 +/-30 5.6
C102	2113740B76	CAP CHIP REEL CL1 +/-30 1500
C103	2113740B48	CAP CHIP REEL CL1 +/-30 91
C126	2113740B09	CAP CHIP REEL CL1 +/-30 2.2
C127 thru C129	2113741N45	CAP CHIP CL2 X7R 10% 10000
C130	2113740B34	CAP CHIP REEL CL1 +/-30 24
C131	2113740B76	CAP CHIP REEL CL1 +/-30 1500
C132	2113740B34	CAP CHIP REEL CL1 +/-30 24

ITEM	MOTOROLA PART NUMBER	DESCRIPTION
C133 thru C135	2113740B13	CAP CHIP REEL CL1 +/-30 3.3
C136	2113740B46	CAP CHIP REEL CL1 +/-30 75
C137	2113741N45	CAP CHIP CL2 X7R 10% 10000
C138	2113740B09	CAP CHIP REEL CL1 +/-30 2.2
CR100	4882958R78	DIODE 48R82958R01 A/P 5.6V
E125	2680015P02	SHLD RXFE UHF TIN PLATED
E126	2680002M02	SHLD INJ FLTR TIN PLATED
HY126	9180209N04	FLTR BANDPASS CERAMIC 497 MHZ
L125	2480140E10	INDUCTOR CHIP 100NH
L126 & L127	2480140E01	INDUCTOR CHIP 1.2 UH
L128	2480091G21	COIL AIRWOUND
L129	2480091G33	COIL AIRWOUND
MP126	0780091P01	BRACKET RX FE UHF
MP127	0780214N01	FRAME PRESELECTOR LEAD
MP128	4280191N01	CLIP RECEIVER GROUNDING
MP129	4280013P01	RETAINER WIRE
MP130	4380025P01	SPACER WIRE
Q100 & Q125	4802000P02	NEC SILICON TR 2SC3357 RE
Q126	4880141L01	TSTR PNP SOT23 LO PROFILE TAPE
R100	0611077A26	RES CHIP 10 5 1/8W
R101	0611077A26	RES CHIP 10 5 1/8W
R102	0611077A70	RES CHIP 680 5 1/8W
R103	0611077A62	RES CHIP 330 5 1/8W
R104	0611077A43	RES CHIP 51 5 1/8W
R126	0611077A74	RES CHIP 1000 5 1/8
R127	0611077A36	RES CHIP 27 5 1/8W
R128	0611077A52	RES CHIP 120 5 1/8W
R129	0611077A80	RES CHIP 1800 5 1/8
R130	0611077A94	RES CHIP 6800 5 1/8
R131	0611077A50	RES CHIP 100 5 1/8W
R132	0611077A43	RES CHIP 51 5 1/8W
W128	3080152M07	CBL COAX ASSEMBLY
W642	3080037R05	CABLE ASSEMBLY
	0980212N02	RECP COAX PCB MOUNT
	8480241N02	HYBRID CKT BD UHF F/E

HRE6001B and HRE6002C UHF RXFE Standard Parts List

ITEM	MOTOROLA PART NUMBER	DESCRIPTION
C125	2113740B76	CAP CHIP REEL CL1 +/-30 1500
C126	2113740B09 2113740B11	CAP CHIP REEL CL1 +/-30 2.7 ² CAP CHIP REEL CL1 +/-30 2.7 ¹
C127	2113741N45	CAP CHIP CL2 X7R 10% 10000 ¹
C128 & C129	2113741N45	CAP CHIP CL2 X7R 10% 10000
C130	2113740B34	CAP CHIP REEL CL1 +/-30 24
C131	2113740B76	CAP CHIP REEL CL1 +/-30 1500
C132	2113740B34	CAP CHIP REEL CL1 +/-30 24
C133 thru C135	2113740B13 2113740B17	CAP CHIP REEL CL1 +/-30 3.3 ² CAP CHIP REEL CL1 +/-30 4.7 ¹
C136	2113740B46	CAP CHIP REEL CL1 +/-30 75
C137	2113741N45	CAP CHIP CL2 X7R 10% 10000
C138	2113740B09 2113740B17	CAP CHIP REEL CL1 +/-30 2.2 ² CAP CHIP REEL CL1 +/-30 4.7 ¹
E125	2680015P02	SHLD RXFE UHF TIN PLATED
E126	2680002M02	SHLD INJ FLTR TIN PLATED
HY126	9180209N02	FLTR BANDPASS CERAMIC 455 MHZ ²
HY5126	9180209N01	FLTR BANDPASS CERAMIC 417 MHZ ¹
JU125	0611077A01	RES CHIP JUMPER ¹
JU5125	-----	PART NOT USED ¹
L125	2480140E10	INDUCTOR CHIP 100NH
L126 & L127	2480140E01	INDUCTOR CHIP 1.2 UH
L128	2480091G21	COIL AIRWOUND
L129	2480091G33	COIL AIRWOUND
MP127	0780214N01	FRAME PRESELECTOR LEAD
MP128	4280191N01	CLIP RECEIVER GROUNDING
MP129	4280013P01	RETAINER WIRE
MP130	4380025P01	SPACER WIRE
MP156	0780091P01	BRACKET RX FE UHF
Q125	4802000P02	NEC SILICON TR 2SC3357 RE
Q126	4880141L01	TSTR PNP SOT23 LO PROFILE TAPE

ITEM	MOTOROLA PART NUMBER	DESCRIPTION
R126	0611077A74	RES CHIP 1000 5 1/8
R127	0611077A36	RES CHIP 27 5 1/8W ¹
R128	0611077A52	RES CHIP 120 5 1/8W
R129	0611077A80	RES CHIP 1800 5 1/8
R130	0611077A90 0611077A94	RES CHIP 4700 5 1/8 ¹ RES CHIP 6800 5 1/8 ²
R131	0611077A46 0611077A50	RES CHIP 68 5 1/8W ¹ RES CHIP 100 5 1/8W ²
R132	0611077A43	RES CHIP 51 5 1/8W
W128	3080152M07	CBL COAX ASSEMBLY
W642	3080037R05	CABLE ASSEMBLY
	8480241N02	HYBRID CKT BD UHF F/E

Notes:

- Valid in HRE6001B only.
- Valid in HRE6002C only.

HRE6003B and HRE6004B UHF RXFE Standard Parts List

ITEM	MOTOROLA PART NUMBER	DESCRIPTION
C100, C101 & C103	-----	NOTPLACED
C125	2113740B76	CAP CHIP REEL CL1 +/-30 1500
C126	2113740B09	CAP CHIP REEL CL1 +/-30 2.2
C127 thru C129	2113741N45	CAP CHIP CL2 X7R 10% 10000
C130	2113740B34	CAP CHIP REEL CL1 +/-30 24
C131	2113740B76	CAP CHIP REEL CL1 +/-30 1500
C132	2113740B34	CAP CHIP REEL CL1 +/-30 24
C133 thru C135	2113740B13	CAP CHIP REEL CL1 +/-30 3.3
C136	2113740B46	CAP CHIP REEL CL1 +/-30 75
C137	2113741N45	CAP CHIP CL2 X7R 10% 10000
C138	2113740B09	CAP CHIP REEL CL1 +/-30 2.2
CR100	-----	NOTPLACED
E125	2680015P02	SHLD RXFE UHF TIN PLATED
E126	2680002M02	SHLD INJ FLTR TIN PLATED
HY126	9180209N03 9180209N04	FLTR BANDPASS CERAMIC 465 MHZ ¹ FLTR BANDPASS CERAMIC 497 MHZ ²
L125	2480140E10	INDUCTOR CHIP 100NH
L126	2480140E01	INDUCTOR CHIP 1.2 UH
L127	2480140E01	INDUCTOR CHIP 1.2 UH

ITEM	MOTOROLA PART NUMBER	DESCRIPTION
L128	2480091G21	COIL AIRWOUND
L129	2480091G33	COIL AIRWOUND
MP126	0780091P01	BRACKET RX FE UHF
MP127	0780214N01	FRAME PRESELECTOR LEAD
MP128	4280191N01	CLIP RECEIVER GROUNDING
MP129	4280013P01	RETAINER WIRE
MP130	4380025P01	SPACER WIRE
Q100	-----	NOTPLACED
Q125	4802000P02	NEC SILICON TR 2SC3357 RE
Q126	4880141L01	TSTR PNP SOT23 LO PROFILE TAPE
R100 thru R104	-----	NOTPLACED
R126	0611077A74	RES CHIP 1000 5 1/8
R127	0611077A36	RES CHIP 27 5 1/8W
R128	0611077A52	RES CHIP 120 5 1/8W
R129	0611077A80	RES CHIP 1800 5 1/8
R130	0611077A94	RES CHIP 6800 5 1/8
R131	0611077A50	RES CHIP 100 5 1/8W
R132	0611077A26 0611077A43	RES CHIP 10 5 1/8W ² RES CHIP 51 5 1/8W ¹
W128	3080152M07	CBL COAX ASSEMBLY
W642	3080037R05	CABLE ASSEMBLY
	0980212N02	RECP COAX PCB MOUNT
	0980110M01	RECP COAX PCB MOUNT
	8480241N02	HYBRID CKT BD UHF F/E

Notes:

- Valid in HRE6003B only.
- Valid in HRE6004B only.

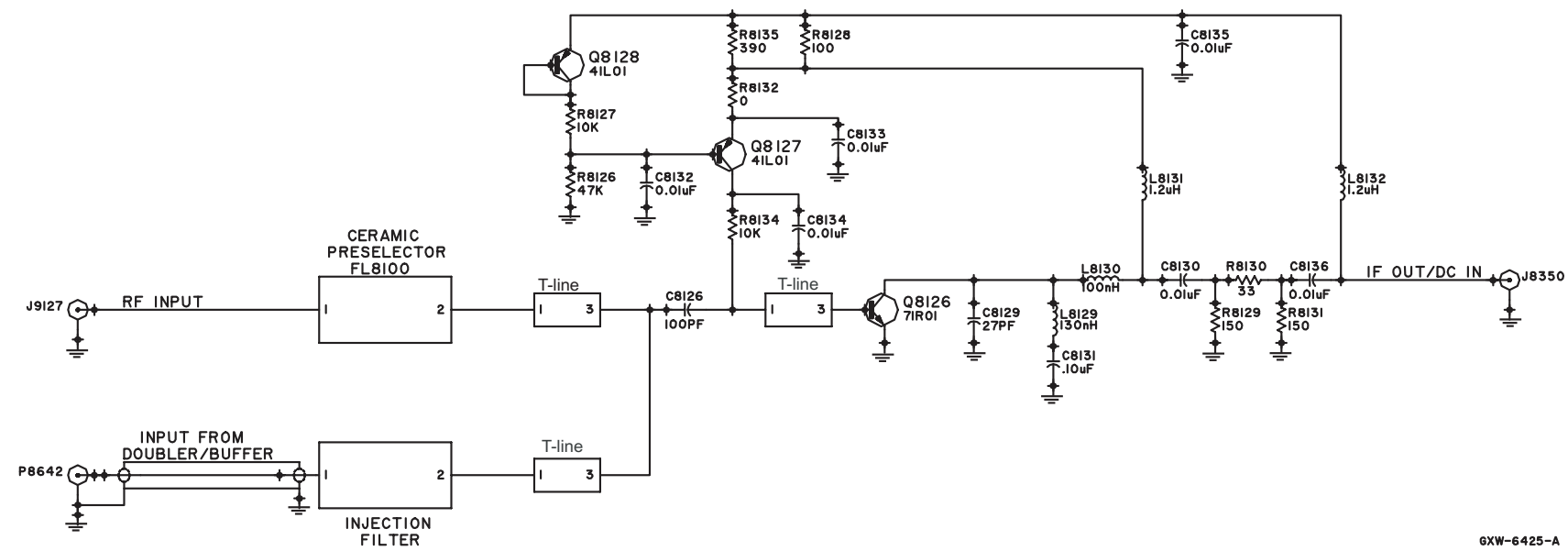

HRF6004B/C 800 MHz Receiver Front-End Schematic Diagram

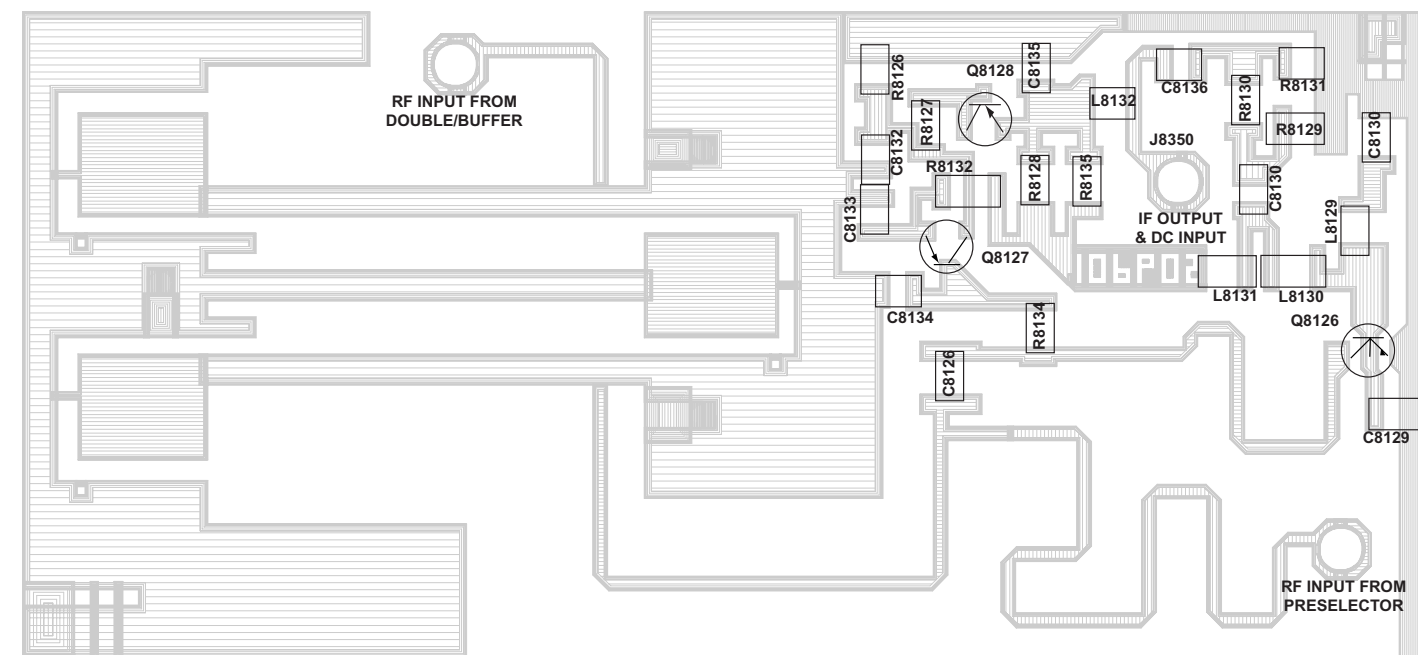

HRF6004B/C 800 MHz Receiver Front-End Component Location Diagram

HRF6004B/C 800 MHz RXFE Parts List

ITEM	MOTOROLA PART NUMBER	DESCRIPTION
C8126	2111078B42	CAP CHIP RF 100 5 NPO 100V
C8129	2111059D57	CAP CHIP 21D84873H57 A/I
C8130	2111059B11	CAP CHIP 21D84547A11 A/I
C8131	2113741N69	CAP CHIP CL2 X7R 10% 100000
C8132 thru C8136	2111059B11	CAP CHIP 21D84547A11 A/I
E8126	9180087M02	FILTER CER 6 P 938MHZ
E8127	2680002M02	SHLD INJ FLTR TIN PLATED
E8130	2680010N02	SHLD RCVR FNT END TIN PLATED
J9127	0980110M01	RECP COAX PCB MOUNT
L8129	2480140E06	INDUCTOR CHIP 130 NH
L8130	2480140E10	INDUCTOR CHIP 100NH
L8131	2480140E01	INDUCTOR CHIP 1.2 UH
L8132	2480140E01	INDUCTOR CHIP 1.2 UH
MP8126	0780259M02	FRAME TIN PLATED
MP8127	6480100P01	SBSTR RECEIVER FRONT END
MP8128	0780031P01	BRKT RCVR FRONT END
Q8126	4802000P02	NEC SILICON TR 2SC3357 RE
Q8127	4880141L01	TSTR PNP SOT23 LO PROFILE TAPE
Q8128	4880141L01	TSTR PNP SOT23 LO PROFILE TAPE
R8126	0611077B15	RES CHIP 47K 5 1/8W
R8127	0611077A98	RES CHIP 10K 5 1/8W
R8128	0611077A50	RES CHIP 100 5 1/8W
R8129	0611077A54	RES CHIP 150 5 1/8W
R8130	0611077A38	RES CHIP 33 5 1/8W
R8131	0611077A54	RES CHIP 150 5 1/8W
R8132	0611077A01	RES CHIP JUMPER
R8134	0611077A98	RES CHIP 10K 5 1/8W
R8135	0611077A64	RES CHIP 390 5 1/8W
W8127	3080037R05	CABLE ASSEMBLY
W8128	3080152M07	CBL COAX ASSEMBLY
	4285615C01	CLIP, GROUND
	8480106P02	BD THK FLM MIXER

7.8 Power Amplifier Section

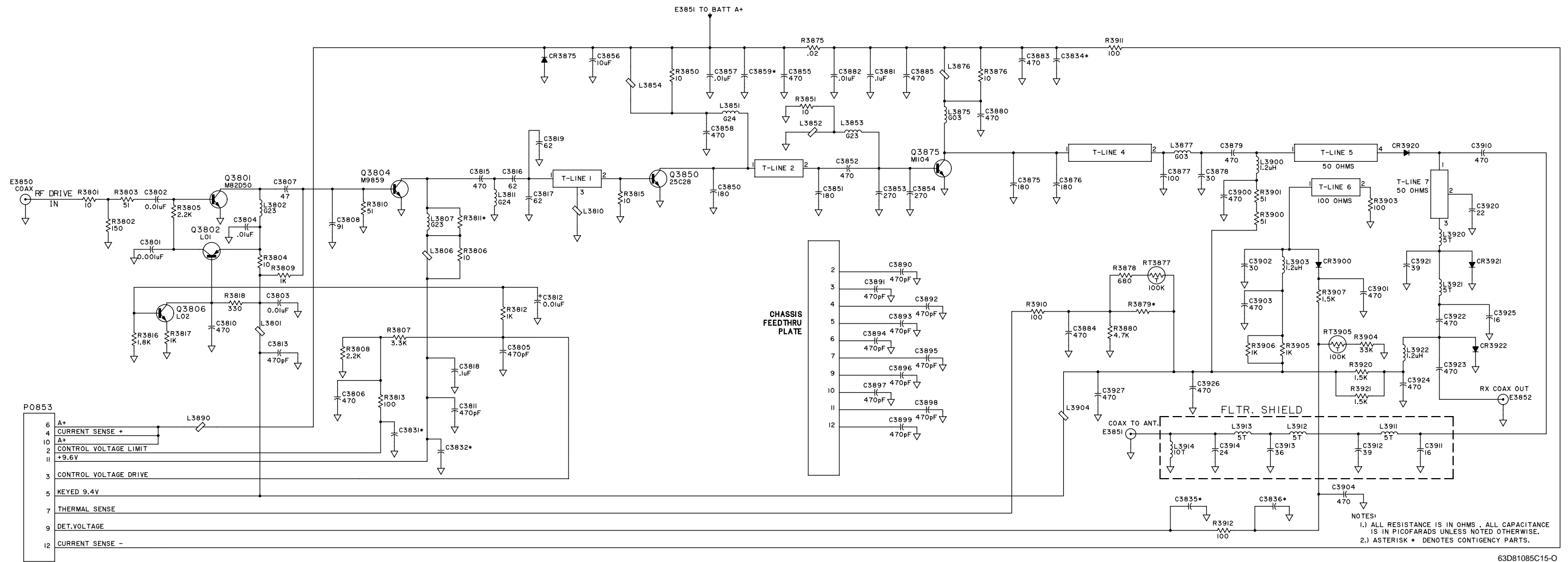

63D81085C15-O

HLD6022C VHF 50 Watt PA Schematic

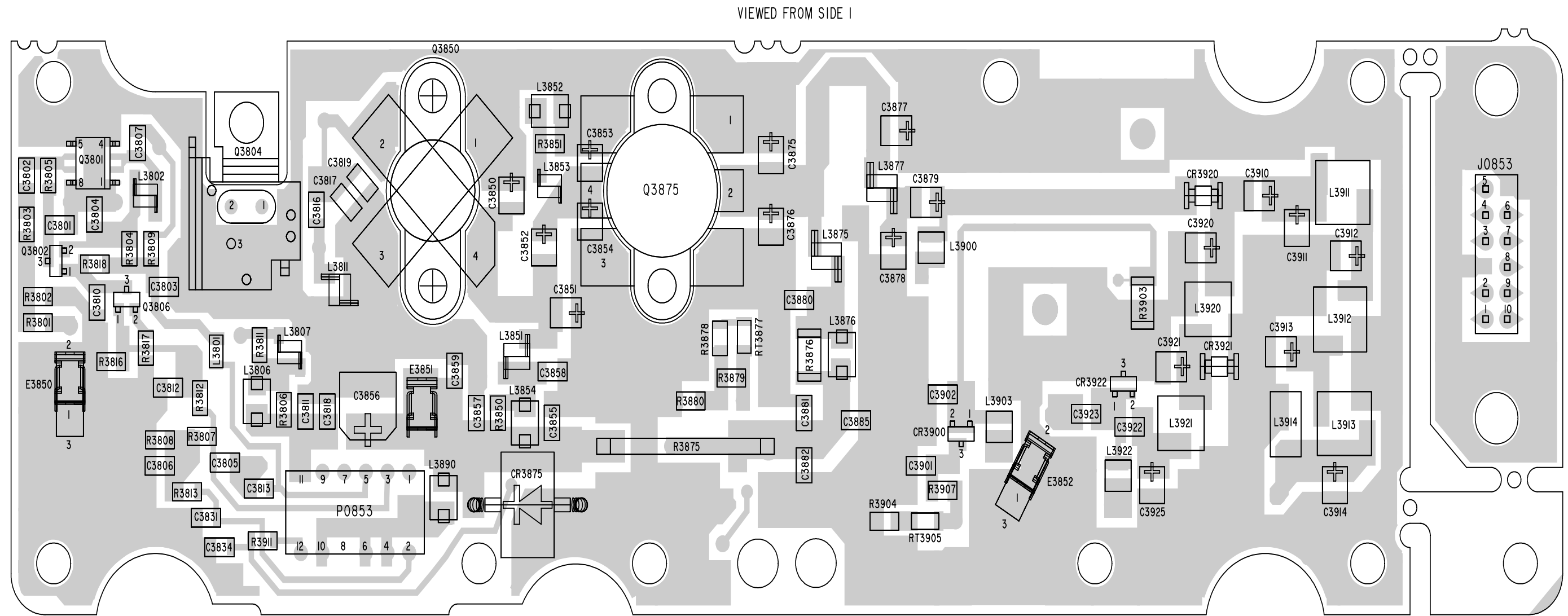

HLD6022C VHF 50-Watt PA Component Location Diagram, Side 1

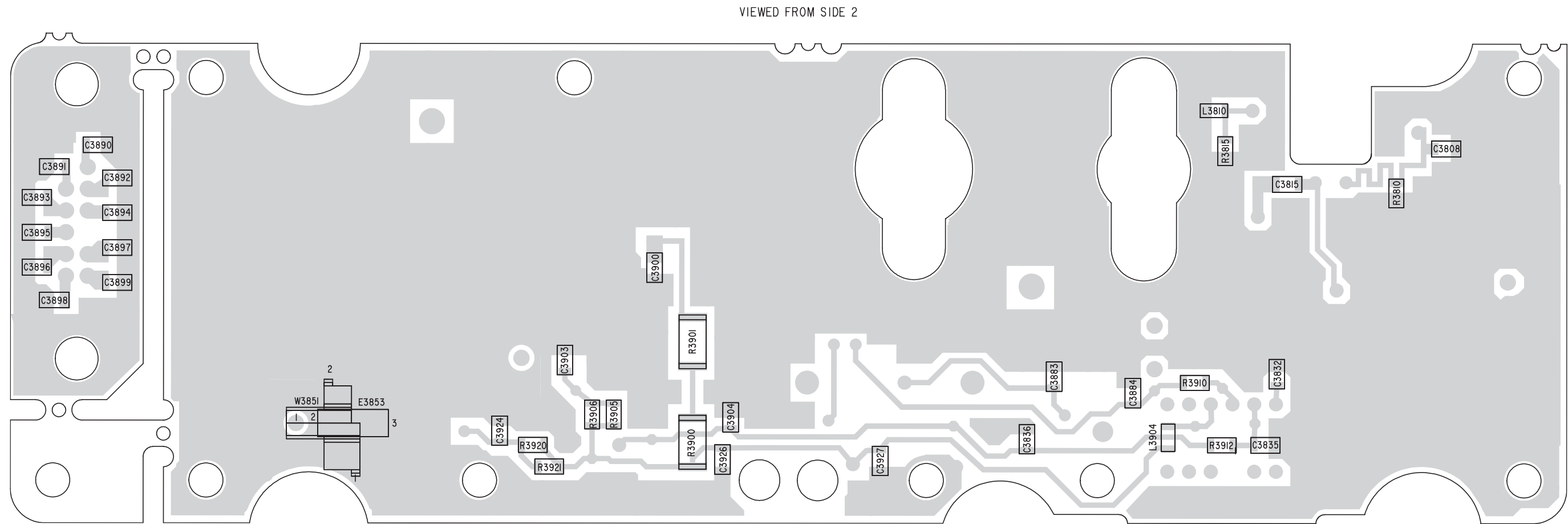

HLD6022C VHF 50-Watt PA Component Location Diagram, Side 2

HLD6022C VHF 50-Watt PA Parts List

ITEM	MOTOROLA PART NUMBER	DESCRIPTION
C3801	2113741N21	CAP CHIP CL2 X7R 10% 1000
C3802	2113741N45	CAP CHIP CL2 X7R 10% 10000 thru C3805
C3806	2113740B65	CAP CHIP REEL CL1 +/-30 470
C3807	2113740B41	CAP CHIP REEL CL1 +/-30 47
C3808	2113740B48	CAP CHIP REEL CL1 +/-30 91
C3810 & C3811	2113740B65	CAP CHIP REEL CL1 +/-30 470
C3812	2113741N45	CAP CHIP CL2 X7R 10% 10000
C3813 & C3815	2113740B65	CAP CHIP REEL CL1 +/-30 470
C3816 & C3817	2113740B44	CAP CHIP REEL CL1 +/-30 62
C3818	2113741N69	CAP CHIP CL2 X7R 10% 100000
C3819	2113740B44	CAP CHIP REEL CL1 +/-30 62
C3831 & C3832	-----	NOTPLACED
C3834	2113743G24	CAP CHIP 2.2 UF 16V +80-20%
C3835 & C3836	-----	NOTPLACED
C3850	2111078B49	CAP CHIP RF 180 5 NPO 100V thru C3852
C3855	2113740B65	CAP CHIP REEL CL1 +/-30 470
C3856	2380090M24	CAP ALU 10 20 50V SURF MT
C3857	2113741N45	CAP CHIP CL2 X7R 10% 10000
C3858	2113740B65	CAP CHIP REEL CL1 +/-30 470
C3859	2113741N69	CAP CHIP CL2 X7R 10% 100000
C3875 & C3876	2111078B49	CAP CHIP RF 180 5 NPO 100V
C3877	2111078B42	CAP CHIP RF 100 5 NPO 100V
C3878	2111078B27	CAP CHIP RF 30 5 NPO 100V
C3879	2111078B59	CAP CHIP RF 470 5 NPO 100V
C3880	2113740B65	CAP CHIP REEL CL1 +/-30 470
C3881	2113741N69	CAP CHIP CL2 X7R 10% 100000
C3882	2113741N45	CAP CHIP CL2 X7R 10% 10000
C3883	2113740B65	CAP CHIP REEL CL1 +/-30 470 thru C3885
C3890	2113740B65	CAP CHIP REEL CL1 +/-30 470 thru C3901
C3902	2113740B36	CAP CHIP REEL CL1 +/-30 30
C3903 & C3904	2113740B65	CAP CHIP REEL CL1 +/-30 470
C3910	2111078B59	CAP CHIP RF 470 5 NPO 100V
C3911	2111078B19	CAP CHIP RF 16 5 NPO 100V

ITEM	MOTOROLA PART NUMBER	DESCRIPTION
C3912	2111078B19	CAP CHIP RF 16 5 NPO 100V
C3913	2111078B31	CAP CHIP RF 36 5 NPO 100V
C3914	2111078B23	CAP CHIP RF 24 5 NPO 100V
C3920 & C3921	2111078B22	CAP CHIP RF 22 5 NPO 100V
C3922	2113740B65	CAP CHIP REEL CL1 +/-30 470 thru C3924
C3925	2111078B19	CAP CHIP RF 16 5 NPO 100V
C3926 & C3927	2113740B65	CAP CHIP REEL CL1 +/-30 470
CR3875	4880236E07	DIODE TRANSIENT SUP
CR3900	4813825A05	DIODE 30V HOT CARRIER MMBD301L
CR3920 & CR3921	4880236E24	DIODE PIN
CR3922	4805119G18	DIODE SMBD1023 STEP RECOVERY
E3800	2680187N02	HEATSINK, TO39
E3801	2680188N02	SHLD HAR FILTER FENCE TIN PLAT
E3803	8480176N34	BD CK 50W PA PNL
E3850	2980014A03	CLIP COAX TERMINAL thru E3852
L3801	2480067M01	CHK RF CHIP BEAD INDUCTOR 28MZ
L3802	2480091G23	COIL AIRWOUND
L3806	2484657R01	INDUCTOR BEAD CHIP
L3807	2480091G23	COIL AIRWOUND
L3810	2480067M01	CHK RF CHIP BEAD INDUCTOR 28MZ
L3811 & L3851	2480091G24	COIL AIRWOUND
L3852	2484657R01	INDUCTOR BEAD CHIP
L3853	2480091G23	COIL AIRWOUND
L3854	2484657R01	INDUCTOR BEAD CHIP
L3875	2480090G03	COIL AIRWOUND
L3876	2484657R01	INDUCTOR BEAD CHIP
L3877	2480090G03	COIL AIRWOUND
L3890	2484657R01	INDUCTOR BEAD CHIP
L3900 & L3903	2480140E01	INDUCTOR CHIP 1.2 UH
L3904	2480067M01	CHK RF CHIP BEAD INDUCTOR 28MZ
L3911	2480090G15	COIL AIRWOUND
L3912	2480090G10	COIL AIRWOUND
L3913	2480090G15	COIL AIRWOUND
L3914	2480090G13	COIL AIRWOUND
L3920 & L3921	2480090G14	COIL AIRWOUND
L3922	2480140E01	INDUCTOR CHIP 1.2 UH
P0850	2880102M06	PLUG VERTICAL 12 POSITION

ITEM	MOTOROLA PART NUMBER	DESCRIPTION
P0853	0980103M04	RECEPTICAL RIGHT ANGLE 12 POS
Q3801	4880182D50	TSTR SI SORF 4V 750MW 960MHZ
Q3802	4880141L01	TSTR PNP SOT23 LO PROFILE TAPE
Q3804	4800869859	TSTR NPN 69859
Q3806	4880141L02	TSTR NPN SOT23 LO PROFILE TAPE
Q3850	4880225C28	TSTR RF MRF2628 IN FLANGE PKG
Q3875	4884411L04	TSTR M1104
R3801	0611077A26	RES CHIP 10 5 1/8W
R3802	0611077A54	RES CHIP 150 5 1/8W
R3803	0611077A43	RES CHIP 51 5 1/8W
R3804	0611077A26	RES CHIP 10 5 1/8W
R3805	0611077A82	RES CHIP 2200 5 1/8
R3806	0611077A26	RES CHIP 10 5 1/8W
R3807	0611077A86	RES CHIP 3300 5 1/8
R3808	0611077A82	RES CHIP 2200 5 1/8
R3809	0611077A74	RES CHIP 1000 5 1/8
R3810	0611077A43	RES CHIP 51 5 1/8W
R3811	-----	NOTPLACED
R3812	0611077A74	RES CHIP 1000 5 1/8
R3813	0611077A50	RES CHIP 100 5 1/8W
R3815	0611077A26	RES CHIP 10 5 1/8W
R3816	0611077A80	RES CHIP 1800 5 1/8
R3817	0611077A74	RES CHIP 1000 5 1/8
R3818	0611077A62	RES CHIP 330 5 1/8W
R3850	0611077A26	RES CHIP 10 5 1/8W
R3851	0611077A26	RES CHIP 10 5 1/8W
R3875	1780228N02	RESISTOR SHUNT
R3876	0680195M01	RES CHIP 10 OHMS 5% .5W
R3878	0611077A70	RES CHIP 680 5 1/8W
R3879	-----	NOTPLACED
R3880	0611077A90	RES CHIP 4700 5 1/8
R3900 & R3901	0680194M18	RES 51 OHMS 5% 1W
R3903	0680195M25	RES CHIP 100 OHMS 5% .5W
R3904	0611077B11	RES CHIP 33K 5 1/8W
R3905 & R3906	0611077A74	RES CHIP 1000 5 1/8
R3907	0611077A78	RES CHIP 1500 5 1/8
R3910	0611077A50	RES CHIP 100 5 1/8W thru R3912
R3920 & R3921	0611077A72	RES CHIP 820 5 1/8W
RT3877 & RT3905	0680149M02	THERMISTOR CHIP 100K OHM

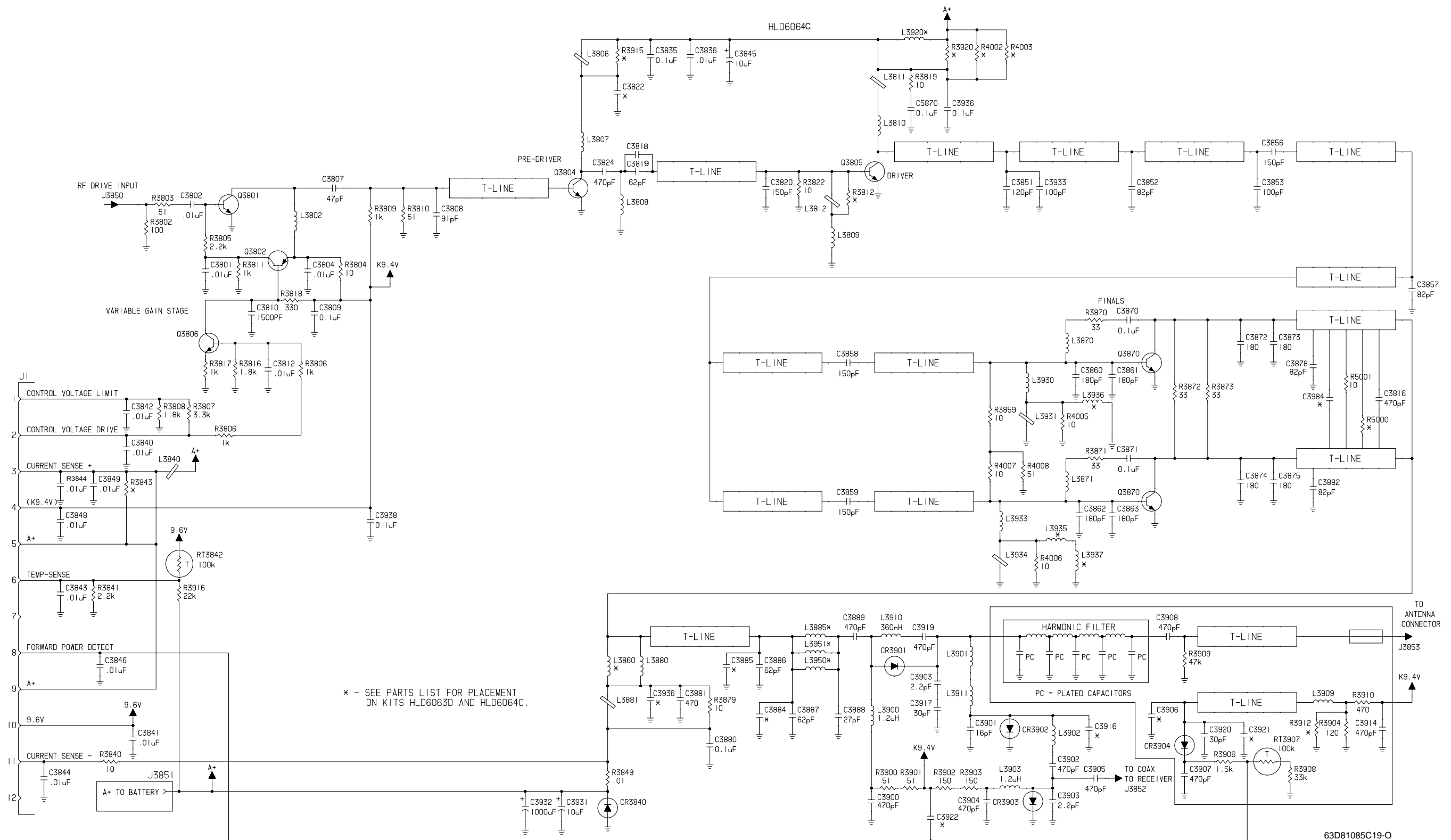

HLD6064C VHF Range 1 and HLD6063D Range 2 100-Watt PA Schematic

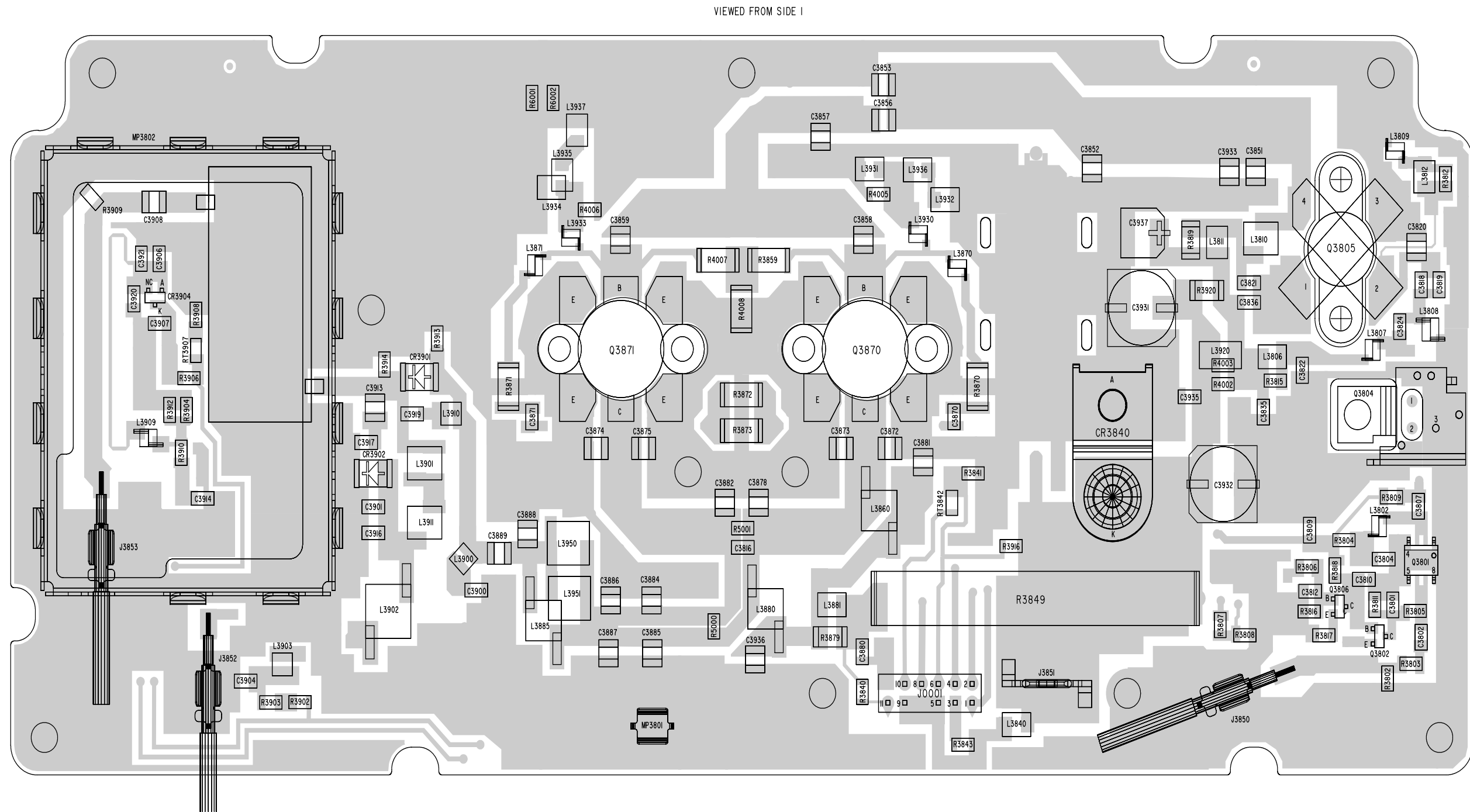

HLD6064C VHF Range 1 and HLD6063D Range 2 100-Watt PA Component Location Diagram, Side 1

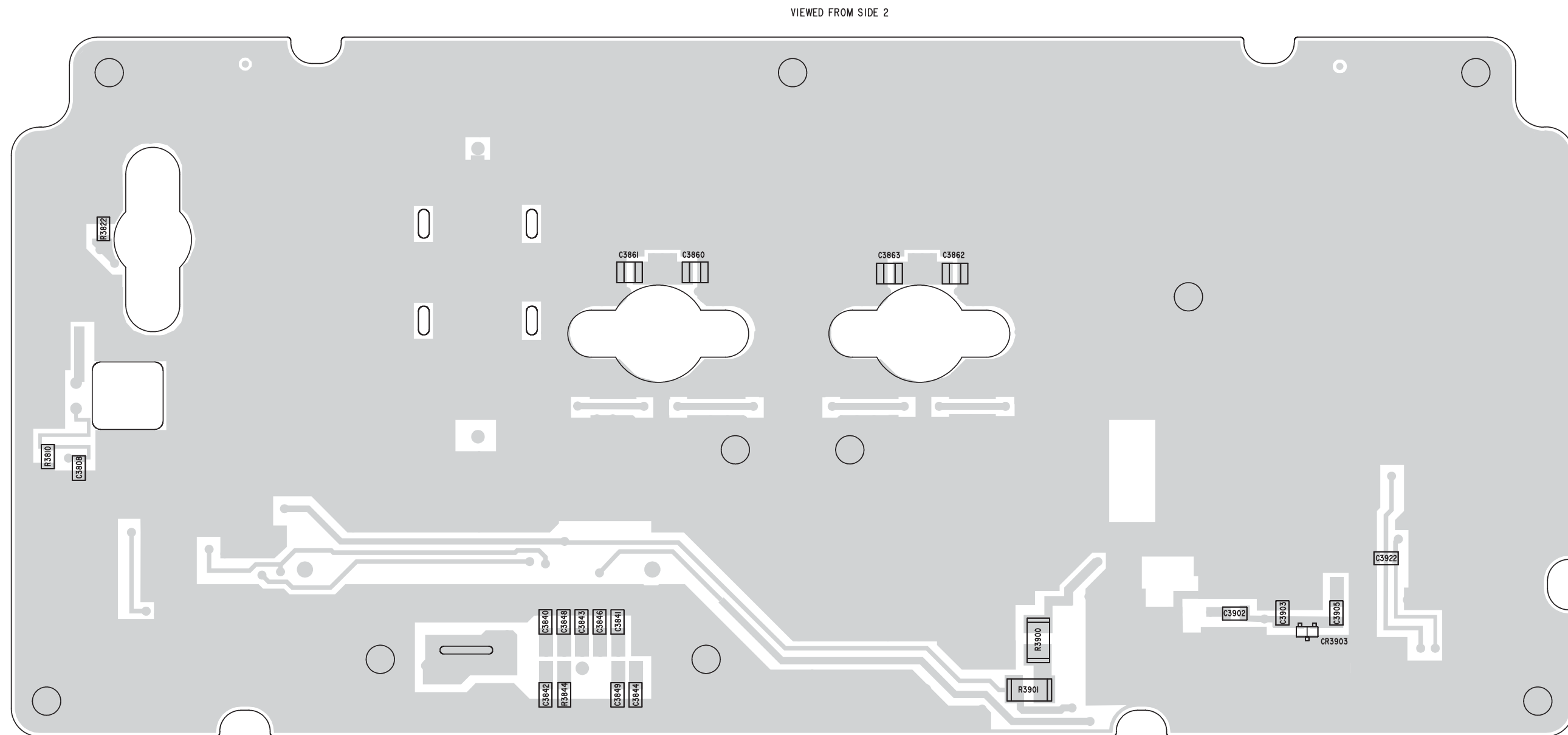

HLD6064C VHF Range 1 and HLD6063D Range 2 100-Watt PA Component Location Diagram, Side 2

**HLD6064C VHF R1 and HLD6063D R2 100-Watt PA
Parts List**

ITEM	MOTOROLA PART NUMBER	DESCRIPTION
C3801 & C3802	2113741N45	CAP CHIP CL2 X7R 10% 10000
C3804	2113741N45	CAP CHIP CL2 X7R 10% 10000
C3807	2113740B36	CAP CHIP REEL CL1 +/-30 30
C3808	2113740B48	CAP CHIP REEL CL1 +/-30 91
C3809	2113741N69	CAP CHIP CL2 X7R 10% 100000
C3810	2113740B76	CAP CHIP REEL CL1 +/-30 1500
C3812	2113741N45	CAP CHIP CL2 X7R 10% 10000
C3816	2113740B65	CAP CHIP REEL CL1 +/-30 470
C3818	2113740B39 ¹ 2113740B36 ²	CAP CHIP REEL CL1 +/-30 39 CAP CHIP REEL CL1 +/-30 30
C3819	2113740B35 ¹ 2113740B36 ²	CAP CHIP REEL CL1 +/-30 27 CAP CHIP REEL CL1 +/-30 30
C3820	2111078B49 ¹ 2111078B47 ²	CAP CHIP RF 180 5 NPO 100V CAP CHIP RF 150 5 NPO 100V
C3821	2113740B65	CAP CHIP REEL CL1 +/-30 470
C3824	2113740B65 ¹ 2113740B57 ²	CAP CHIP REEL CL1 +/-30 470 CAP CHIP REEL CL1 +/-30 220
C3835	2113741N69	CAP CHIP CL2 X7R 10% 100000
C3836	2113741N45 ¹ 2113741N69 ²	CAP CHIP CL2 X7R 10% 10000 CAP CHIP CL2 X7R 10% 100000
C3840 thru C3844	2113741N45	CAP CHIP CL2 X7R 10% 10000
C3846 thru C3849	2113741N45	CAP CHIP CL2 X7R 10% 10000
C3851	2111078B44	CAP CHIP RF 120 5 NPO 100V
C3852	2111078B40	CAP CHIP RF 82 5 NPO 100V
C3853	2111078B44 ¹ 2111078B42 ²	CAP CHIP RF 120 5 NPO 100V CAP CHIP RF 100 5 NPO 100V
C3856	2111078B59 ¹ 2111078B51 ²	CAP CHIP RF 470 5 NPO 100V CAP CHIP RF 220 5 NPO 100V
C3857	2111078B47 ¹ 2111078B44 ²	CAP CHIP RF 150 5 NPO 100V CAP CHIP RF 120 5 NPO 100V
C3858 thru C3859	2111078B49 ¹ 2111078B47 ²	CAP CHIP RF 180 5 NPO 100V CAP CHIP RF 150 5 NPO 100V
C3860	2111078B49	CAP CHIP RF 180 5 NPO 100V
C3861 & C3862	2111078B51 ¹ 2111078B49 ²	CAP CHIP RF 220 5 NPO 100V CAP CHIP RF 180 5 NPO 100V
C3863	2111078B49	CAP CHIP RF 180 5 NPO 100V
C3870 & C3871	2113741N69	CAP CHIP CL2 X7R 10% 100000
C3872 thru C3875	2111078B49	CAP CHIP RF 180 5 NPO 100V
C3878	2111078B40 ¹ 2111078B37 ²	CAP CHIP RF 82 5 NPO 100V CAP CHIP RF 62 5 NPO 100V
C3880	2113741N69	CAP CHIP CL2 X7R 10% 100000

ITEM	MOTOROLA PART NUMBER	DESCRIPTION
C3881	2111078B59	CAP CHIP RF 470 5 NPO 100V
C3882	2111078B40 ¹ 2111078B37 ²	CAP CHIP RF 82 5 NPO 100V CAP CHIP RF 62 5 NPO 100V
C3886	2111078B40	CAP CHIP RF 82 5 NPO 100V
C3887	2111078B40 ¹ 2111078B37 ²	CAP CHIP RF 82 5 NPO 100V CAP CHIP RF 62 5 NPO 100V
C3888	2111078B27 ¹ 2111078B25 ²	CAP CHIP RF 30 5 NPO 100V CAP CHIP RF 27 5 NPO 100V
C3889	2111078B59	CAP CHIP RF 470 5 NPO 100V
C3900	2113740B65	CAP CHIP REEL CL1 +/-30 470
C3901	2113740B30	CAP CHIP REEL CL1 +/-30 16
C3902	2113740B65	CAP CHIP REEL CL1 +/-30 470
C3903	2113740B09	CAP CHIP REEL CL1 +/-30 2.2
C3904 & C3905	2113740B65	CAP CHIP REEL CL1 +/-30 470
C3907	2113740B65	CAP CHIP REEL CL1 +/-30 470
C3908	2111078B59	CAP CHIP RF 470 5 NPO 100V
C3913	2111078B19 ¹ 2111078B15 ²	CAP CHIP RF 16 5 NPO 100V CAP CHIP RF 12 5 NPO 100V
C3914	2113740B65	CAP CHIP REEL CL1 +/-30 470
C3917	2113740B36	CAP CHIP REEL CL1 +/-30 30
C3919	2113740B65	CAP CHIP REEL CL1 +/-30 470
C3920	2113740B36	CAP CHIP REEL CL1 +/-30 30
C3931 & C3932	2380090M32	CAP ALU 220 20 35V
C3933	2111078B44 ¹ 2111078B42 ²	CAP CHIP RF 120 5 NPO 100V CAP CHIP RF 100 5 NPO 100V
C3935	2113741N69	CAP CHIP CL2 X7R 10% 100000
C3936	2111078B59	CAP CHIP RF 470 5 NPO 100V
C3937	2380090M24	CAP ALU 10 20 50V SURF MT
CR3840	4880222R01	DIODE REVERSE POLARITY SPECTRA
CR3901 & CR3902	4880121R01	PWR PIN DIODE SMD TAPE & REEL
CR3903	4880142L01	DIODE PIN SOT 23 MMBV 3401
CR3904	4813825A05	DIODE 30V HOT CARRIER MMBD301L
J0001	2880102M11	PLUG VERTICAL 12 POS
J3850	4280088P01	CLIP COAX
J3851	2980119R01	TERMINAL POWER
J3852 & J3853	4280088P01	CLIP COAX
L3802	2480091G23	COIL AIRWOUND
L3806	2484657R01	INDUCTOR BEAD CHIP
L3807	2480091G23	COIL AIRWOUND
L3808	2480091G24	COIL AIRWOUND
L3809	2480091G23	COIL AIRWOUND
L3810	2480090G16	COIL AIRWOUND RF 000.000
L3811 & L3812	2484657R01	INDUCTOR BEAD CHIP
L3840	2484657R01	INDUCTOR BEAD CHIP

ITEM	MOTOROLA PART NUMBER	DESCRIPTION
L3860	2480090G19 ¹	COIL AIRWOUND
L3870 & L3871	2480091G23	COIL AIRWOUND
L3880	2480090G19 ²	COIL AIRWOUND
L3881	2484657R01	INDUCTOR BEAD CHIP
L3900	2480140E01	INDUCTOR CHIP 1.2 UH
L3901	2480090G16	COIL AIRWOUND RF 000.000
L3902	2480090G20	COIL AIRWOUND
L3903	2480140E01	INDUCTOR CHIP 1.2 UH
L3909	2480091G21	COIL AIRWOUND
L3910	2480140E11	INDUCTOR CHIP 360 NH
L3911	2480090G16	COIL AIRWOUND RF 000.000
L3920	2480090G13 ¹	COIL AIRWOUND
L3930	2480091G23	COIL AIRWOUND
L3931	2484657R01	INDUCTOR BEAD CHIP
L3933	2480091G23	COIL AIRWOUND
L3934	2484657R01	INDUCTOR BEAD CHIP
L3950 & L3951	2480090G10	COIL AIRWOUND
MP0001	1580208R01 ²	COVER HARMONIC SHIELD
MP0003	3080114R01 ²	CBL ASSEM PWR CONN
MP0006	4280261R01 ²	CLIP COAX
MP3801	4280202R02	CLIP COAX TIN PLATED
MP3802	2680139P02	SHLD HAR FLTR TIN PLATED
Q3801	4880182D50	TSTR SI SORF 4V 750MW 960MHZ
Q3802	4880141L01	TSTR PNP SOT23 LO PROFILE TAPE
Q3804	4800869859	TSTR NPN 69859
Q3805	4880225C22	TSTR NPN 174MHZ 3/30W MRF1946
Q3806	4880141L02	TSTR NPN SOT23 LO PROFILE TAPE
Q3870 & Q3871	4884411L04	TSTR M1104
R3802	0611077A46 ¹ 0611077A50 ²	RES CHIP 68 5 1/8W RES CHIP 100 5 1/8W
R3803	0611077A46	RES CHIP 68 5 1/8W
R3804	0611077A26	RES CHIP 10 5 1/8W
R3805	0611077A82	RES CHIP 2200 5 1/8
R3806	0611077A74	RES CHIP 1000 5 1/8
R3807	0611077A86 ¹ 0611077A82 ²	RES CHIP 3300 5 1/8 RES CHIP 2200 5 1/8
R3808	0611077A80	RES CHIP 1800 5 1/8
R3809	0611077A74 ¹ 0611077A70 ²	RES CHIP 1000 5 1/8 RES CHIP 680 5 1/8W
R3810	0611077A43	RES CHIP 51 5 1/8W
R3811	0611077A74	RES CHIP 1000 5 1/8
R3816	0611077A80	RES CHIP 1800 5 1/8
R3817	0611077A74	RES CHIP 1000 5 1/8
R3818	0611077A62	RES CHIP 330 5 1/8W
R3819	0680195M01	RES CHIP 10 OHMS 5% .5W

ITEM	MOTOROLA PART NUMBER	DESCRIPTION
R3822	0611077A26	RES CHIP 10 5 1/8W
R3840	0611077A50	RES CHIP 100 5 1/8W
R3841	0611077A80	RES CHIP 1800 5 1/8
R3843	0611077A50	RES CHIP 100 5 1/8W
R3844	0611077B15 ²	RES CHIP 47K 5 1/8W
R3849	1780165C02	RES SHUNT
R3859	0680194M01	RES 10 OHMS 5% 1W
R3870 & R3871	0680194M18	RES 51 OHMS 5% 1W
R3872 & R3873	0680194M13	RES 33 OHMS 5% 1W
R3879	0680195M01	RES CHIP 10 OHMS 5% .5W
R3900 & R3901	0680194M18	RES 51 OHMS 5% 1W
R3902 & R3903	0611077A54	RES CHIP 150 5 1/8W
R3904	0611077A52	RES CHIP 120 5 1/8W
R3906	0611077A78	RES CHIP 1500 5 1/8
R3908	0611077B11	RES CHIP 33K 5 1/8W
R3909	0611077B15	RES CHIP 47K 5 1/8W
R3910	0611077A66	RES CHIP 470 5 1/8W
R3913 & R3914	0611077B47	RES CHIP 1 MEG 5 1/8W
R3916	0611077B07	RES CHIP 22K 5 1/8W
R3920	0680195M01	RES CHIP 10 OHMS 5% .5W
R4402 & R4003	0611077A01 ²	RES CHIP JUMPER
R4005 & R4006	0611077A32 ¹ 0611077A26 ²	RES CHIP 18 5 1/8W RES CHIP 10 5 1/8W
R4007	0680194M01	RES 10 OHMS 5% 1W
R4008	0680194M18	RES 51 OHMS 5% 1W
R5001	0611077A26	RES CHIP 10 5 1/8W
R6001	0611077A01 ¹	RES CHIP JUMPER
R6002	0611077A01 ²	RES CHIP JUMPER
RT3842 & RT3907	0680149M02	THERMISTOR CHIP 100K OHM
	8480112P05	BD CKT VHF
	3080152M13	CBL COAX ASSEM
	3080261M06	CBL ANTENNA CONN
	0180756T06	HYBRID BD HAR FLTR VHF SPECTRA

Notes;

- Valid in HLD6064C only.
- Valid in HLD6063D only.

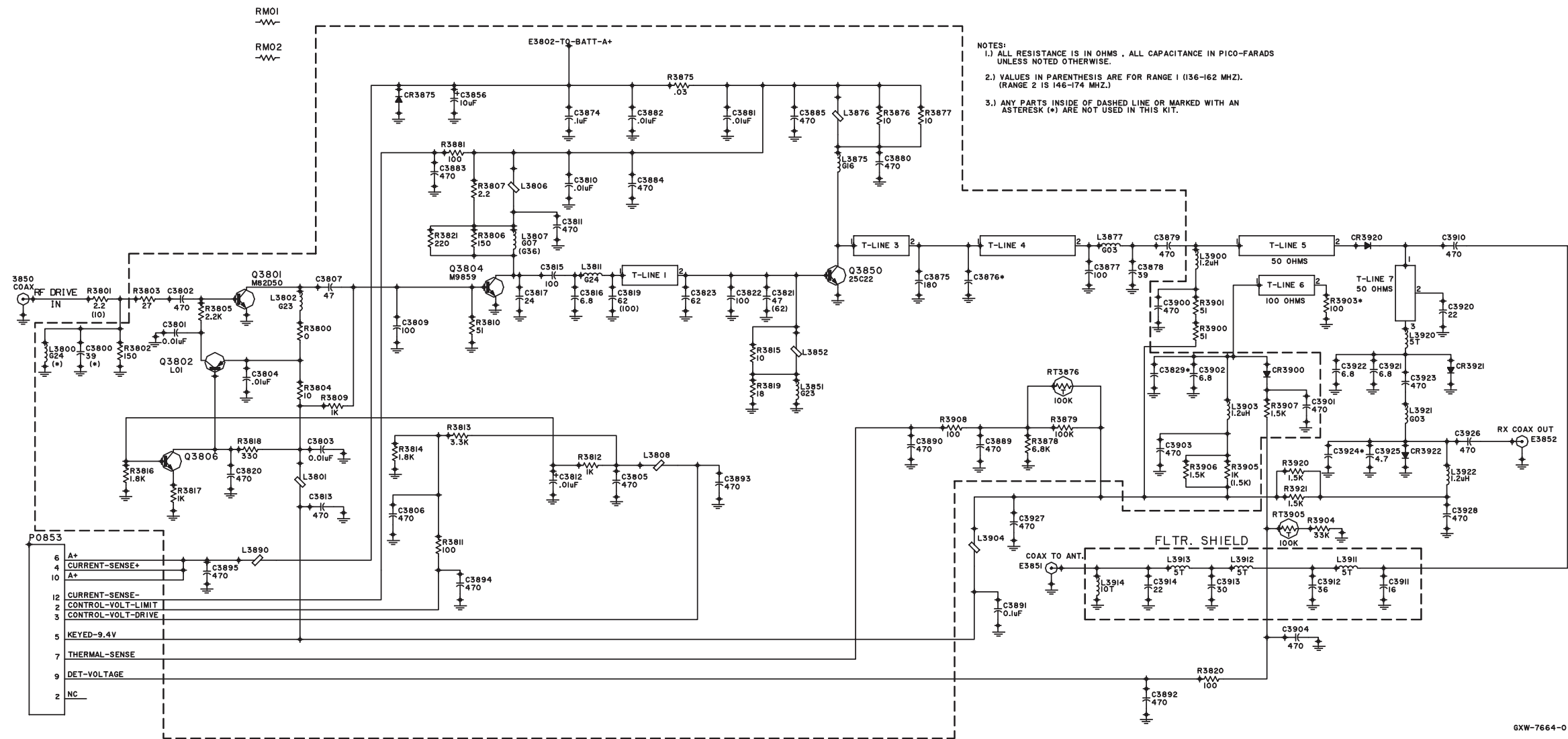

HLD6032B/HLD6066B VHF 25-Watt PA Schematic

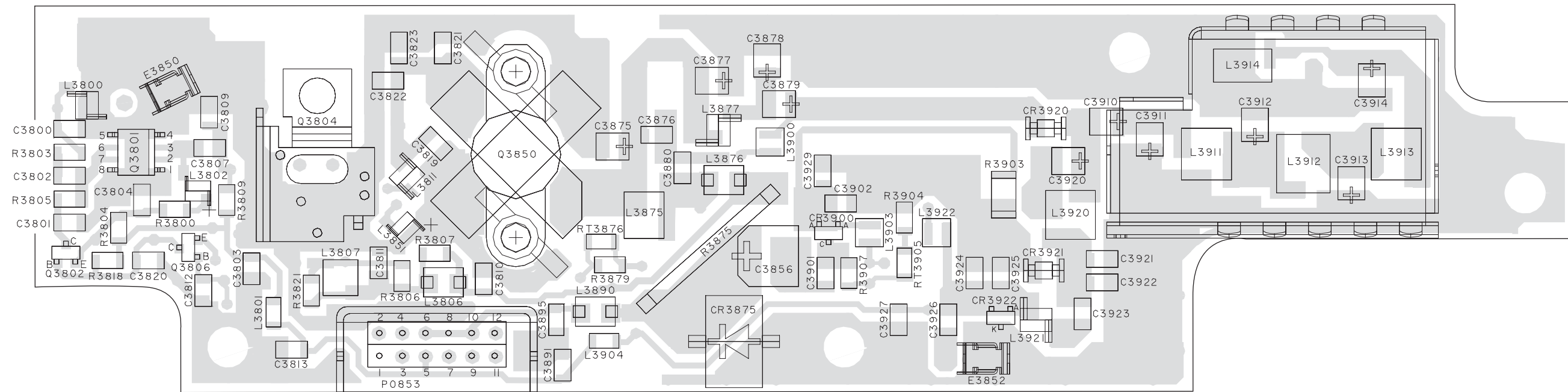

HLD6032B/HLD6066B VHF 25-Watt PA Component Location Diagram, Side 1

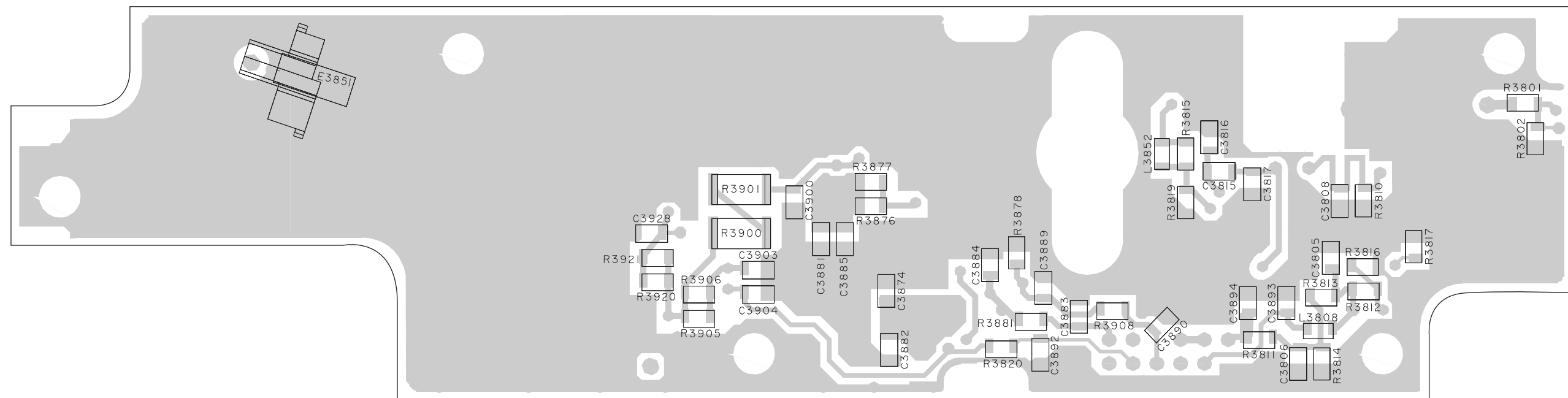

HLD6032B/HLD6066B VHF 25-Watt PA Component Location Diagram, Side 2

HLD6032B VHF R2 25-Watt PA Parts List

ITEM	MOTOROLA PART NUMBER	DESCRIPTION
C3800	2113740B39	CAP CHIP REEL CL1 +/-30 39
C3801	2113741N45	CAP CHIP CL2 X7R 10% 10000
C3802	2113740B65	CAP CHIP REEL CL1 +/-30 470
C3803	2113741N69	CAP CHIP CL2 X7R 10% 100000
C3804	2113741N45	CAP CHIP CL2 X7R 10% 10000
C3805 & C3806	2113740B65	CAP CHIP REEL CL1 +/-30 470
C3807	2113740B39	CAP CHIP REEL CL1 +/-30 39
C3809	2113740B49	CAP CHIP REEL CL1 +/-30 100
C3810	2113741N45	CAP CHIP CL2 X7R 10% 10000
C3811	2113740B65	CAP CHIP REEL CL1 +/-30 470
C3812	2113741N69	CAP CHIP CL2 X7R 10% 100000
C3813	2113740B65	CAP CHIP REEL CL1 +/-30 470
C3815	2113740B49	CAP CHIP REEL CL1 +/-30 100
C3816	2113740B21	CAP CHIP REEL CL1 +/-30 6.8
C3817	2113740B34	CAP CHIP REEL CL1 +/-30 24
C3819	2113740B44	CAP CHIP REEL CL1 +/-30 62
C3820	2113740B65	CAP CHIP REEL CL1 +/-30 470
C3821	2113740B41	CAP CHIP REEL CL1 +/-30 47
C3822	2113740B49	CAP CHIP REEL CL1 +/-30 100
C3823	2113740B44	CAP CHIP REEL CL1 +/-30 62
C3856	2380090M24	CAP ALU 10 20 50V SURF MT
C3874	2113741N69	CAP CHIP CL2 X7R 10% 100000
C3875	2111078B49	CAP CHIP RF 180 5 NPO 100V
C3877	2111078B42	CAP CHIP RF 100 5 NPO 100V
C3879	2111078B59	CAP CHIP RF 470 5 NPO 100V
C3880	2113740B65	CAP CHIP REEL CL1 +/-30 470
C3881	2113741N45	CAP CHIP CL2 X7R 10% 10000
C3882	2113741N45	CAP CHIP CL2 X7R 10% 10000
C3883 thru C3885	2113740B65	CAP CHIP REEL CL1 +/-30 470
C3889 & C3890	2113740B65	CAP CHIP REEL CL1 +/-30 470
C3891	2113741N69	CAP CHIP CL2 X7R 10% 100000
C3892 thru C3895	2113740B65	CAP CHIP REEL CL1 +/-30 470
C3900 & C3901	2113740B65	CAP CHIP REEL CL1 +/-30 470
C3902	2113740B23	CAP CHIP REEL CL1 +/-30 8.2
C3903	2113740B65	CAP CHIP REEL CL1 +/-30 470
C3904	2113740B65	CAP CHIP REEL CL1 +/-30 470
C3910	2111078B59	CAP CHIP RF 470 5 NPO 100V
C3911	2111078B19	CAP CHIP RF 16 5 NPO 100V
C3912	2111078B31	CAP CHIP RF 36 5 NPO 100V
C3913	2111078B27	CAP CHIP RF 30 5 NPO 100V
C3914 & C3920	2111078B22	CAP CHIP RF 22 5 NPO 100V

ITEM	MOTOROLA PART NUMBER	DESCRIPTION
C3921 & C3922	2113740B21	CAP CHIP REEL CL1 +/-30 6.8
C3923	2113740B65	CAP CHIP REEL CL1 +/-30 470
C3925	2113740B17	CAP CHIP REEL CL1 +/-30 4.7
C3926 thru C3928	2113740B65	CAP CHIP REEL CL1 +/-30 470
CR3875	4880236E07	DIODE TRANSIENT SUP
CR3900	4813825A05	DIODE 30V HOT CARRIER MMBD301L
CR3922	4805119G18	DIODE SMBD1023 STEP RECOVERY
E3800	2680187N02	HEATSINK, TO39
E3803	8480259N33	CKT BD VHF 25W PANEL
E3804	8480259N03	CKT BD VHF 25W PA
E3850	2980014A03	CLIP COAX TERMINAL
E3851	3080152M10	CBL COAX ASSEMBLY
E3852	2980014A03	CLIP COAX TERMINAL
E3854	3080152M02	CABLE COAX ASSEMBLY
L3800	2480091G24	COIL AIRWOUND
L3801	2480067M01	CHK RF CHIP BEAD INDUCTOR 28MZ
L3802	2480091G23	COIL AIRWOUND
L3807	2480091G07	COIL AIRWOUND
L3808	2480067M01	CHK RF CHIP BEAD INDUCTOR 28MZ
L3811	2480091G24	COIL AIRWOUND
L3851	2480091G23	COIL AIRWOUND
L3852	2480067M01	CHK RF CHIP BEAD INDUCTOR 28MZ
L3875	2480090G16	COIL AIRWOUND RF 000.000
L3877	2480090G03	COIL AIRWOUND
L3900 & L3903	2480140E01	INDUCTOR CHIP 1.2 UH
L3904	2480067M01	CHK RF CHIP BEAD INDUCTOR 28MZ
L3911	2480090G15	COIL AIRWOUND
L3912	2480090G10	COIL AIRWOUND
L3913	2480090G15	COIL AIRWOUND
L3914	2480090G13	COIL AIRWOUND
L3920	2480090G14	COIL AIRWOUND
L3921	2480090G03	COIL AIRWOUND
L3922	2480140E01	INDUCTOR CHIP 1.2 UH
P0853	6480262N01	PLATE LP FEEDTHRU ASSEMBLY
Q3801	4880182D50	TSTR SI SORF 4V 750MW 960MHZ
Q3802	4880141L01	TSTR PNP SOT23 LO PROFILE TAPE
Q3804	4800869859	TSTR NPN 69859
Q3806	4880141L02	TSTR NPN SOT23 LO PROFILE TAPE

ITEM	MOTOROLA PART NUMBER	DESCRIPTION
Q3850	4880225C22	TSTR NPN 174MHZ 3/30W MRF1946
R3800	0611077A01	RES CHIP JUMPER
R3801	0611077A26	RES CHIP 10 5 1/8W
R3802	0611077A54	RES CHIP 150 5 1/8W
R3803	0611077A36	RES CHIP 27 5 1/8W
R3804	0611077A26	RES CHIP 10 5 1/8W
R3805	0611077A82	RES CHIP 2200 5 1/8
R3806	0611077A54	RES CHIP 150 5 1/8W
R3807	0611077A10	RES CHIP 2.2 5 1/8W
R3809	0611077A74	RES CHIP 1000 5 1/8
R3810	0611077A43	RES CHIP 51 5 1/8W
R3811	0611077A50	RES CHIP 100 5 1/8W
R3812	0611077A74	RES CHIP 1000 5 1/8
R3813	0611077A86	RES CHIP 3300 5 1/8
R3814	0611077A82	RES CHIP 2200 5 1/8
R3815	0611077A26	RES CHIP 10 5 1/8W
R3816	0611077A80	RES CHIP 1800 5 1/8
R3817	0611077A74	RES CHIP 1000 5 1/8
R3818	0611077A62	RES CHIP 330 5 1/8W
R3819	0611077A32	RES CHIP 18 5 1/8W
R3820	0611077A50	RES CHIP 100 5 1/8W
R3821	0611077A58	RES CHIP 220 5 1/8W
R3875	1780228N01	RESISTOR SHUNT
R3876 & R3877	0611077A26	RES CHIP 10 5 1/8W
R3878	0611077A94	RES CHIP 6800 5 1/8
R3879	0611077B23	RES CHIP 100K 5 1/8W
R3881	0611077A50	RES CHIP 100 5 1/8W
R3900 & R3901	0680194M18	RES 51 OHMS 5% 1W
R3903	0680195M25	RES CHIP 100 OHMS 5% .5W
R3904	0611077B11	RES CHIP 33K 5 1/8W
R3905	0611077A74	RES CHIP 1000 5 1/8
R3906 & R3907	0611077A78	RES CHIP 1500 5 1/8
R3908	0611077A50	RES CHIP 100 5 1/8W
R3920 & R3921	0611077A72	RES CHIP 820 5 1/8W
RM0002	0611077A01	RES CHIP JUMPER
RT3876 & RT3905	0680149M02	THERMISTOR CHIP 100K OHM
	2484657R01	INDUCTOR BEAD CHIP
	4880236E24	DIODE PIN
	2111078B32	CAP CHIP RF 39 5 NPO 100V

HLD6066B VHF R1 25-Watt PA Parts List

ITEM	MOTOROLA PART NUMBER	DESCRIPTION
C3801	2113741N45	CAP CHIP CL2 X7R 10% 10000
C3802	2113740B65	CAP CHIP REEL CL1 +/-30 470
C3803	2113741N69	CAP CHIP CL2 X7R 10% 100000
C3804	2113741N45	CAP CHIP CL2 X7R 10% 10000
C3805 & C3806	2113740B65	CAP CHIP REEL CL1 +/-30 470
C3807	2113740B39	CAP CHIP REEL CL1 +/-30 39
C3809	2113740B49	CAP CHIP REEL CL1 +/-30 100
C3810	2113741N45	CAP CHIP CL2 X7R 10% 10000
C3811	2113740B65	CAP CHIP REEL CL1 +/-30 470
C3812	2113741N69	CAP CHIP CL2 X7R 10% 100000
C3813	2113740B65	CAP CHIP REEL CL1 +/-30 470
C3815	2113740B49	CAP CHIP REEL CL1 +/-30 100
C3816	2113740B21	CAP CHIP REEL CL1 +/-30 6.8
C3817	2113740B34	CAP CHIP REEL CL1 +/-30 24
C3819	2113740B47	CAP CHIP REEL CL1 +/-30 82
C3820	2113740B65	CAP CHIP REEL CL1 +/-30 470
C3821 & C3822	2113740B44	CAP CHIP REEL CL1 +/-30 62
C3823	2113740B47	CAP CHIP REEL CL1 +/-30 82
C3856	2380090M24	CAP ALU 10 20 50V SURF MT
C3874	2113741N69	CAP CHIP CL2 X7R 10% 100000
C3875	2111078B49	CAP CHIP RF 180 5 NPO 100V
C3877	2111078B42	CAP CHIP RF 100 5 NPO 100V
C3878	2111078B32	CAP CHIP RF 39 5 NPO 100V
C3879	2111078B59	CAP CHIP RF 470 5 NPO 100V
C3880	2113740B65	CAP CHIP REEL CL1 +/-30 470
C3881 & C3882	2113741N45	CAP CHIP CL2 X7R 10% 10000
C3883 thru C3885 & C3889, C3890	2113740B65	CAP CHIP REEL CL1 +/-30 470
C3891	2113741N69	CAP CHIP CL2 X7R 10% 100000
C3892 thru C3895	2113740B65	CAP CHIP REEL CL1 +/-30 470
C3900 & C3901	2113740B65	CAP CHIP REEL CL1 +/-30 470
C3902	2113740B21	CAP CHIP REEL CL1 +/-30 6.8
C3903 & C3904	2113740B65	CAP CHIP REEL CL1 +/-30 470
C3910	2111078B59	CAP CHIP RF 470 5 NPO 100V
C3911	2111078B19	CAP CHIP RF 16 5 NPO 100V
C3912	2111078B31	CAP CHIP RF 36 5 NPO 100V
C3913	2111078B27	CAP CHIP RF 30 5 NPO 100V
C3914 & C3920	2111078B22	CAP CHIP RF 22 5 NPO 100V
C3921 & C3922	2113740B21	CAP CHIP REEL CL1 +/-30 6.8

ITEM	MOTOROLA PART NUMBER	DESCRIPTION
C3923	2113740B65	CAP CHIP REEL CL1 +/-30 470
C3925	2113740B17	CAP CHIP REEL CL1 +/-30 4.7
C3926 thru C3928	2113740B65	CAP CHIP REEL CL1 +/-30 470
CR3875	4880236E07	DIODE TRANSIENT SUP
CR3900	4813825A05	DIODE 30V HOT CARRIER MMBD301L
CR3920 & CR3921	4880236E24	DIODE PIN
CR3922	4805119G18	DIODE SMBD1023 STEP RECOVERY
E3800	2680187N02	HEATSINK, TO39
E3803	8480259N33	CKT BD VHF 25W PANEL
E3804	8480259N03	CKT BD VHF 25W PA
E3850 & E3852	2980014A03	CLIP COAX TERMINAL
L3801	2480067M01	CHK RF CHIP BEAD INDUCTOR 28MZ
L3802	2480091G23	COIL AIRWOUND
L3806	2484657R01	INDUCTOR BEAD CHIP
L3807	2480091G36	COIL AIRWOUND
L3808	2480067M01	CHK RF CHIP BEAD INDUCTOR 28MZ
L3811	2480091G24	COIL AIRWOUND
L3851	2480091G23	COIL AIRWOUND
L3852	2480067M01	CHK RF CHIP BEAD INDUCTOR 28MZ
L3875	2480090G16	COIL AIRWOUND RF 000.000
L3876	2484657R01	INDUCTOR BEAD CHIP
L3877	2480090G03	COIL AIRWOUND
L3890	2484657R01	INDUCTOR BEAD CHIP
L3900 & L3903	2480140E01	INDUCTOR CHIP 1.2 UH
L3904	2480067M01	CHK RF CHIP BEAD INDUCTOR 28MZ
L3911	2480090G15	COIL AIRWOUND
L3912	2480090G10	COIL AIRWOUND
L3913	2480090G15	COIL AIRWOUND
L3914	2480090G13	COIL AIRWOUND
L3920	2480090G14	COIL AIRWOUND
L3921	2480090G04	COIL AIRWOUND
L3922	2480140E01	INDUCTOR CHIP 1.2 UH
P0853	6480262N01	PLATE LP FEEDTHRU ASSEMBLY
Q3801	4880182D50	TSTR SI SORF 4V 750MW 960MHZ
Q3802	4880141L01	TSTR PNP SOT23 LO PROFILE TAPE
Q3804	4800869859	TSTR NPN 69859
Q3806	4880141L02	TSTR NPN SOT23 LO PROFILE TAPE

ITEM	MOTOROLA PART NUMBER	DESCRIPTION
Q3850	4880225C22	TSTR NPN 174MHZ3/30W MRF1946
R3800	0611077A01	RES CHIP JUMPER
R3801	0611077A26	RES CHIP 10 5 1/8W
R3802	0611077A54	RES CHIP 150 5 1/8W
R3803	0611077A40	RES CHIP 39 5 1/8W
R3804	0611077A26	RES CHIP 10 5 1/8W
R3805	0611077A82	RES CHIP 2200 5 1/8
R3806	0611077A54	RES CHIP 150 5 1/8W
R3807	0611077A10	RES CHIP 2.2 5 1/8W
R3809	0611077A74	RES CHIP 1000 5 1/8
R3810	0611077A43	RES CHIP 51 5 1/8W
R3811	0611077A50	RES CHIP 100 5 1/8W
R3812	0611077A74	RES CHIP 1000 5 1/8
R3813	0611077A86	RES CHIP 3300 5 1/8
R3814	0611077A80	RES CHIP 1800 5 1/8
R3815	0611077A26	RES CHIP 10 5 1/8W
R3816	0611077A80	RES CHIP 1800 5 1/8
R3817	0611077A74	RES CHIP 1000 5 1/8
R3818	0611077A62	RES CHIP 330 5 1/8W
R3819	0611077A32	RES CHIP 18 5 1/8W
R3820	0611077A50	RES CHIP 100 5 1/8W
R3821	0611077A58	RES CHIP 220 5 1/8W
R3875	1780228N01	RESISTOR SHUNT
R3876 & R3877	0611077A26	RES CHIP 10 5 1/8W
R3878	0611077A94	RES CHIP 6800 5 1/8
R3879	0611077B23	RES CHIP 100K 5 1/8W
R3881	0611077A50	RES CHIP 100 5 1/8W
R3900 & R3901	0680194M18	RES 51 OHMS 5% 1W
R3903	0680195M25	RES CHIP 100 OHMS 5% .5W
R3904	0611077B11	RES CHIP 33K 5 1/8W
R3905 thru R3907	0611077A78	RES CHIP 1500 5 1/8
R3908	0611077A50	RES CHIP 100 5 1/8W
R3920 & R3921	0611077A66	RES CHIP 470 5 1/8W
RM01	0611077A01	RES CHIP JUMPER
RT3876 & RT3905	0680149M02	THERMISTOR CHIP 100K OHM

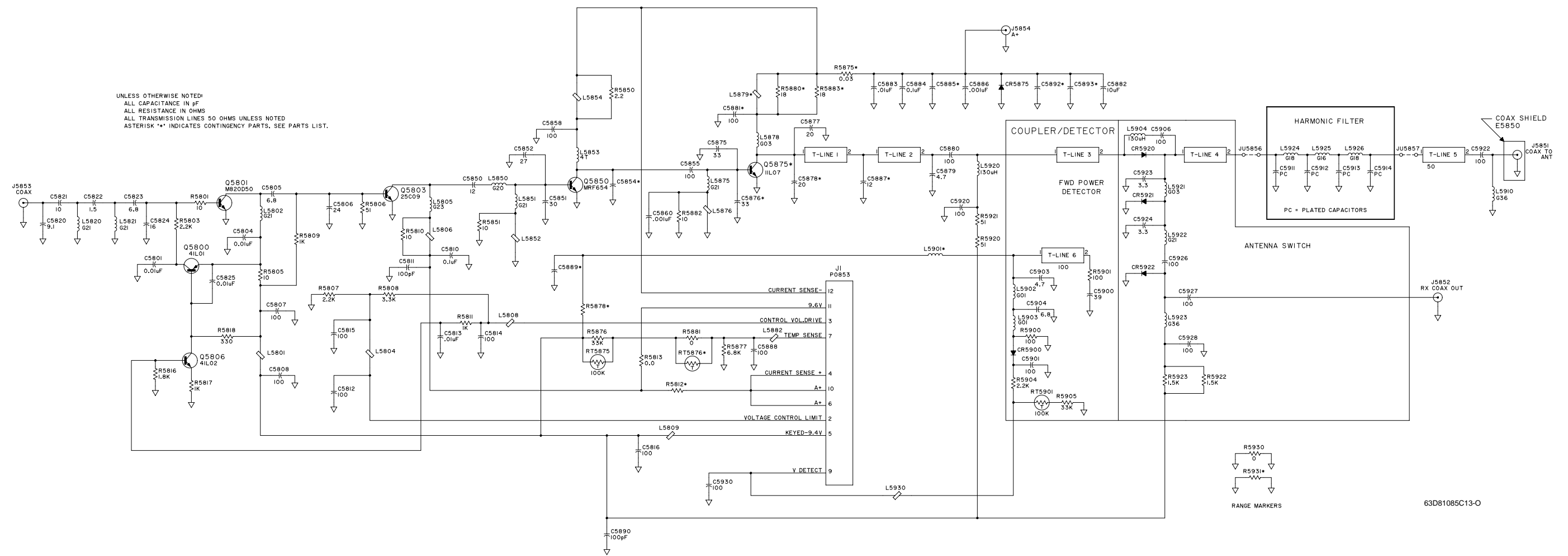

HLE6062B and HLE6071B UHF 25-Watt PA Schematic

VIEWED FROM SIDE 1

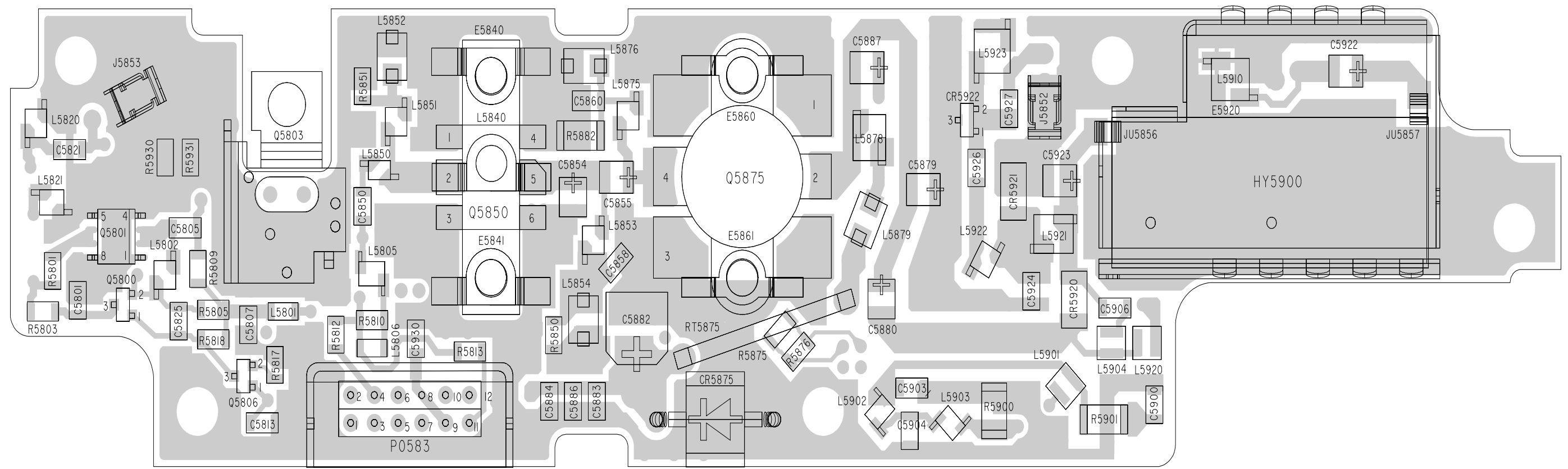

HLE6062B UHF 25-Watt PA Component Location Diagram, Side 1

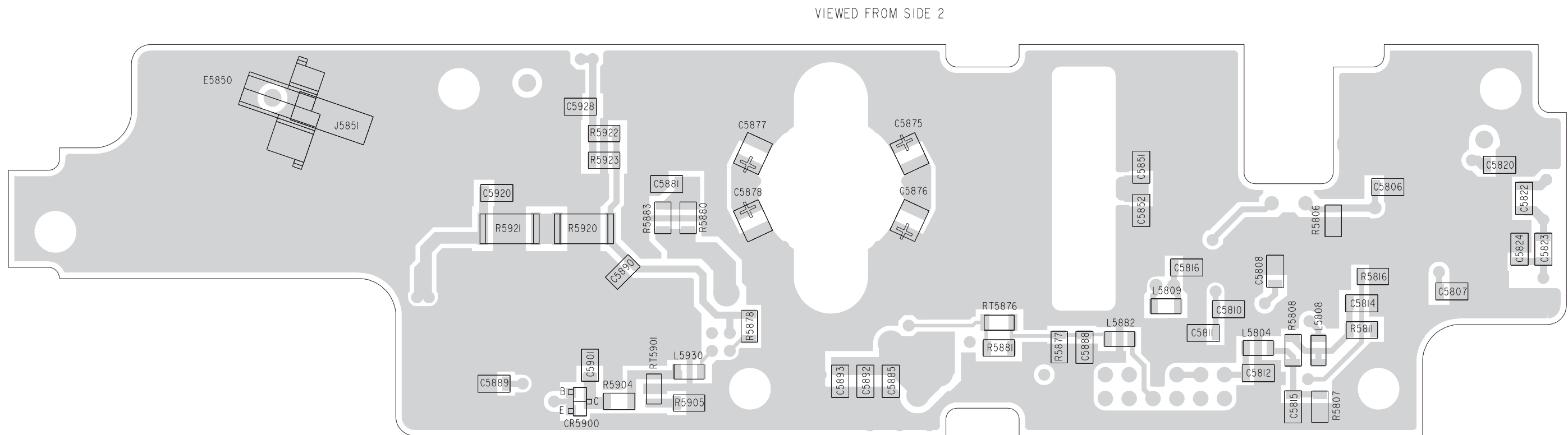

HLE6062B UHF 25-Watt PA Component Location Diagram, Side 2

HLE6062B VHF R2 25-Watt PA Parts List

ITEM	MOTOROLA PART NUMBER	DESCRIPTION
C5801 & C5804	2113741N45	CAP CHIP CL2 X7R 10% 10000
C5805	2113740B21	CAP CHIP REEL CL1 +/-30 6.8
C5806	2113740B34	CAP CHIP REEL CL1 +/-30 24
C5807 & C5808	2113740B49	CAP CHIP REEL CL1 +/-30 100
C5810	2113741N69	CAP CHIP CL2 X7R 10% 100000
C5811 & C5812	2113740B49	CAP CHIP REEL CL1 +/-30 100
C5813	2113741N69	CAP CHIP CL2 X7R 10% 100000
C5814 thru C5816	2113740B49	CAP CHIP REEL CL1 +/-30 100
C5820	2113740B24	CAP CHIP REEL CL1 +/-30 9.1
C5821	2113740B25	CAP CHIP REEL CL1 +/-30 10
C5822	2113740B05	CAP CHIP REEL CL1 +/-30 1.5
C5823	2113740B21	CAP CHIP REEL CL1 +/-30 6.8
C5824	2113740B30	CAP CHIP REEL CL1 +/-30 16
C5825	2113741N45	CAP CHIP CL2 X7R 10% 10000
C5850	2113740B25	CAP CHIP REEL CL1 +/-30 10
C5851	2113740B36	CAP CHIP REEL CL1 +/-30 30
C5852	2113740B35	CAP CHIP REEL CL1 +/-30 27
C5854	2111078B05	CAP CHIP RF 4.7 .25 NPO 100V
C5855	2111078B42	CAP CHIP RF 100 5 NPO 100V
C5858	2113740B49	CAP CHIP REEL CL1 +/-30 100
C5860	2113741N21	CAP CHIP CL2 X7R 10% 1000
C5875 & C5876	2111078B29	CAP CHIP RF 33 5 NPO 100V
C5877 & C5878	2111078B21	CAP CHIP RF 20 5 NPO 100V
C5879	2111078B08	CAP CHIP RF 6.2 .25 NPO 100V
C5880	2111078B42	CAP CHIP RF 100 5 NPO 100V
C5881	2113740B49	CAP CHIP REEL CL1 +/-30 100
C5882	2380090M24	CAP ALU 10 20 50V SURF MT
C5883	2113741N45	CAP CHIP CL2 X7R 10% 10000
C5884	2113741N69	CAP CHIP CL2 X7R 10% 100000
C5885	-----	NOTPLACED
C5886	2113741N21	CAP CHIP CL2 X7R 10% 1000
C5887	2111078B15	CAP CHIP RF 12 5 NPO 100V
C5888	2113740B49	CAP CHIP REEL CL1 +/-30 100
C5889	-----	NOTPLACED
C5890	2113740B49	CAP CHIP REEL CL1 +/-30 100
C5892 & C5893	-----	NOTPLACED
C5900	2113740B39	CAP CHIP REEL CL1 +/-30 39
C5901	2113740B49	CAP CHIP REEL CL1 +/-30 100
C5903 & C5904	2113740B17	CAP CHIP REEL CL1 +/-30 4.7
C5906 & C5920	2113740B49	CAP CHIP REEL CL1 +/-30 100
C5922	2111078B42	CAP CHIP RF 100 5 NPO 100V

ITEM	MOTOROLA PART NUMBER	DESCRIPTION
C5923	2111078B01	CAP CHIP RF 3.3 .25 NPO 100V
C5924	2113740B13	CAP CHIP REEL CL1 +/-30 3.3
C5926 thru C5928 & C5930	2113740B49	CAP CHIP REEL CL1 +/-30 100
CR5875	4880236E07	DIODE TRANSIENT SUP
CR5900	4813825A05	DIODE 30V HOT CARRIER MMBD301L
CR5920 & CR5921	4880236E24	DIODE PIN
CR5922	4805119G18	DIODE SMBD1023 STEP RECOVERY
E5803	2680187N02	HEATSINK, TO39
E5920	2680084N02	SHLD HAR FLTR TIN PLATED
J5852 & J5853	2980014A03	CLIP COAX TERMINAL
L5801	2480067M01	CHK RF CHIP BEAD INDUCTOR 28MZ
L5802	2480091G21	COIL AIRWOUND
L5804	2480067M01	CHK RF CHIP BEAD INDUCTOR 28MZ
L5805	2480091G23	COIL AIRWOUND
L5806	2480067M01	CHK RF CHIP BEAD INDUCTOR 28MZ
L5808 & L5809	2480067M01	CHK RF CHIP BEAD INDUCTOR 28MZ
L5820 & L5821	2480091G21	COIL AIRWOUND
L5850	2480091G20	COIL AIRWOUND
L5851	2480091G21	COIL AIRWOUND
L5852	2484657R01	INDUCTOR BEAD CHIP
L5853	2480091G21	COIL AIRWOUND
L5854	2484657R01	INDUCTOR BEAD CHIP
L5875	2480091G21	COIL AIRWOUND
L5876	2484657R01	INDUCTOR BEAD CHIP
L5878	2480090G03	COIL AIRWOUND
L5879	2484657R01	INDUCTOR BEAD CHIP
L5882	2480067M01	CHK RF CHIP BEAD INDUCTOR 28MZ
L5901	-----	NOTPLACED
L5902 & L5903	2480091G01	COIL AIRWOUND
L5904	2480140E06	INDUCTOR CHIP 130 NH
L5910	2480091G36	COIL AIRWOUND
L5920	2480140E06	INDUCTOR CHIP 130 NH
L5921	2480090G03	COIL AIRWOUND
L5922	2480091G21	COIL AIRWOUND
L5923	2480091G36	COIL AIRWOUND
L5930	2480067M01	CHK RF CHIP BEAD INDUCTOR 28MZ
P0853	6480262N01	PLATE LP FEEDTHRU ASSEMBLY

ITEM	MOTOROLA PART NUMBER	DESCRIPTION
Q5800	4880141L01	TSTR PNP SOT23 LO PROFILE TAPE
Q5801	4880182D50	TSTR SI SORF 4V 750MW 960MHZ
Q5803	4880225C09	TSTR M25C09
Q5806	4880141L02	TSTR NPN SOT23 LO PROFILE TAPE
Q5850	4880225C27	TSTR RF MRF654F IN CS12 PKG
R5801	0611077A26	RES CHIP 10 5 1/8W
R5803	0611077A82	RES CHIP 2200 5 1/8
R5805	0611077A26	RES CHIP 10 5 1/8W
R5806	0611077A43	RES CHIP 51 5 1/8W
R5807	0611077A82	RES CHIP 2200 5 1/8
R5808	0611077A86	RES CHIP 3300 5 1/8
R5809	0611077A74	RES CHIP 1000 5 1/8
R5810	0611077A26	RES CHIP 10 5 1/8W
R5811	0611077A74	RES CHIP 1000 5 1/8
R5812	-----	NOTPLACED
R5813	0611077A01	RES CHIP JUMPER
R5816	0611077A80	RES CHIP 1800 5 1/8
R5817	0611077A74	RES CHIP 1000 5 1/8
R5818	0611077A62	RES CHIP 330 5 1/8W
R5850	0611077A10	RES CHIP 2.2 5 1/8W
R5851	0611077A26	RES CHIP 10 5 1/8W
R5875	1780228N01	RESISTOR SHUNT
R5876	0611077B11	RES CHIP 33K 5 1/8W
R5877	0611077A94	RES CHIP 6800 5 1/8
R5880	0611077A32	RES CHIP 18 5 1/8W
R5881	0611077A01	RES CHIP JUMPER
R5882	0680195M01	RES CHIP 10 OHMS 5% .5W
R5883	0611077A32	RES CHIP 18 5 1/8W
R5900 & R5901	0680195M25	RES CHIP 100 OHMS 5% .5W
R5904	0611077A82	RES CHIP 2200 5 1/8
R5905	0611077B11	RES CHIP 33K 5 1/8W
R5920 & R5921	0680194M18	RES 51 OHMS 5% 1W
R5922 & R5923	0611077A72	RES CHIP 820 5 1/8W
R5930	0611077A01	RES CHIP JUMPER
R5931	-----	NOTPLACED
RT5875	0680149M02	THERMISTOR CHIP 100K OHM
RT5876	-----	NOTPLACED
RT5901	0680149M02	THERMISTOR CHIP 100K OHM
	8480233N32	BD CKT 25W PA UHF PNL
	2280128P01	PIN POLARIZING
	8480233N02	BD CKT 25W PA UHF

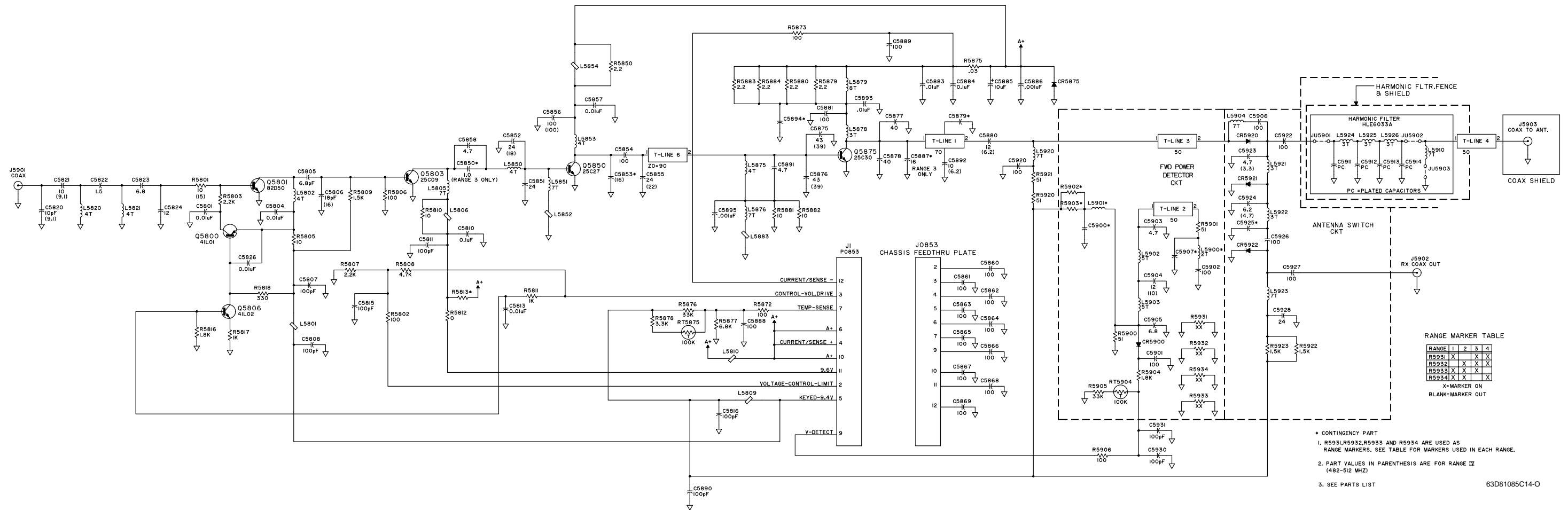

HLE6043C, HLE6044C, and HLE6049B UHF 40-Watt PA Schematic

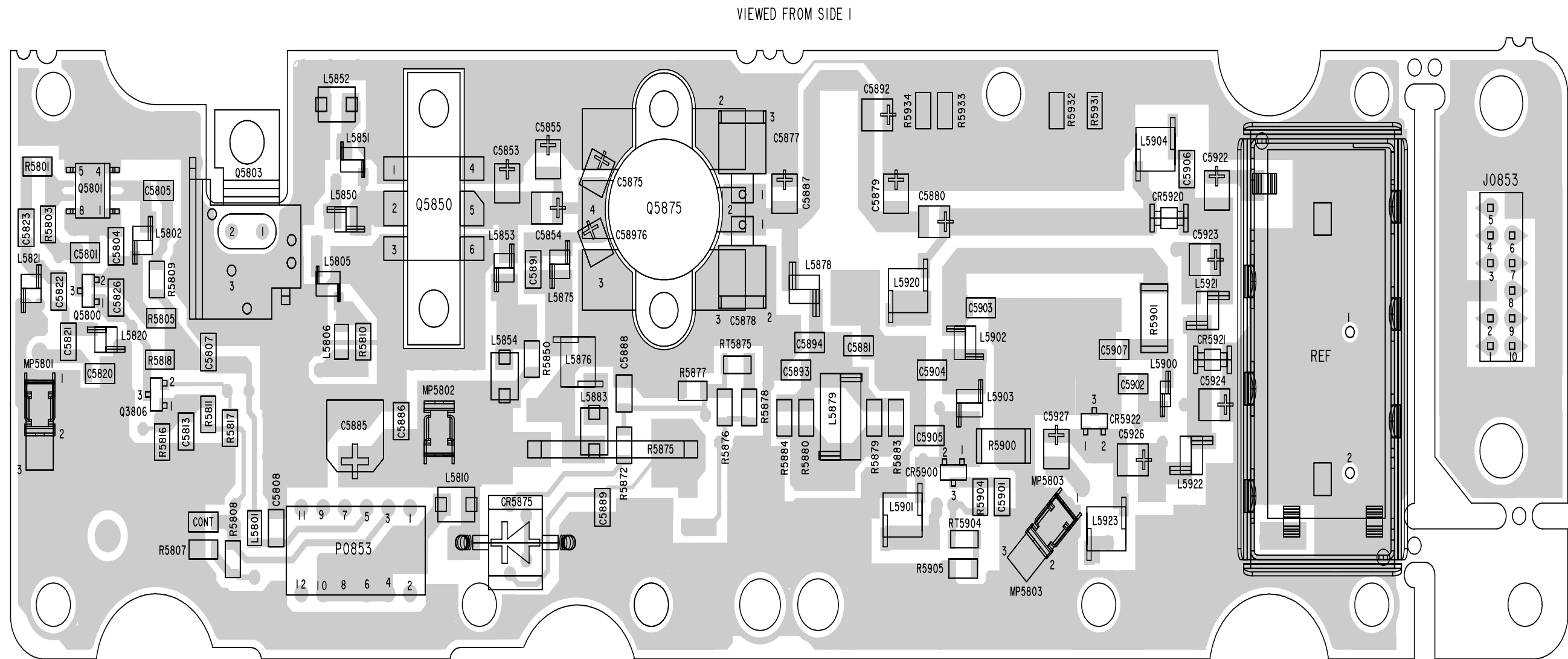

HLE6043C, HLE6044C, and HLE6049B UHF 40-Watt PA Component Location Diagram, Side 1

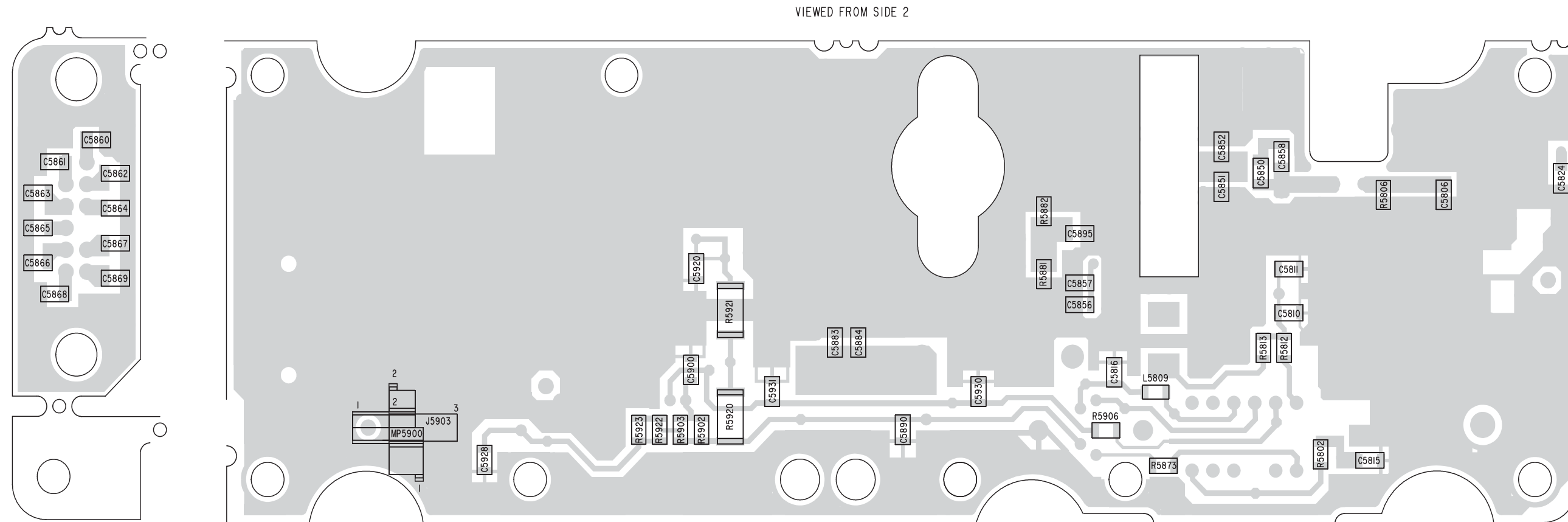

HLE6043C, HLE6044C, and HLE6049B UHF 40-Watt PA Component Location Diagram, Side 2

HLE6043C UHF R3 40-Watt Parts List

ITEM	MOTOROLA PART NUMBER	DESCRIPTION
C5801 & C5804	2113741N45	CAP CHIP CL2 X7R 10% 10000
C5805	2113740B21	CAP CHIP REEL CL1 +/-30 6.8
C5806	2113740B31	CAP CHIP REEL CL1 +/-30 18
C5807 & C5808	2113740B49	CAP CHIP REEL CL1 +/-30 100
C5810	2113741N69	CAP CHIP CL2 X7R 10% 100000
C5811	2113740B49	CAP CHIP REEL CL1 +/-30 100
C5813	2113741N45	CAP CHIP CL2 X7R 10% 10000
C5815	2113740B49	CAP CHIP REEL CL1 +/-30 100
C5816	2113743G24	CAP CHIP 2.2 UF 16V +80-20%
C5820 & C5821	2113740B25	CAP CHIP REEL CL1 +/-30 10
C5822	2113740B05	CAP CHIP REEL CL1 +/-30 1.5
C5823	2113740B21	CAP CHIP REEL CL1 +/-30 6.8
C5824	2113740B27	CAP CHIP REEL CL1 +/-30 12
C5826	2113741N45	CAP CHIP CL2 X7R 10% 10000
C5850	2113740B01	CAP CHIP REEL CL1 +/-30 1.0
C5851 & C5852	2113740B34	CAP CHIP REEL CL1 +/-30 24
C5853	-----	NOTPLACED
C5854	2111078B42	CAP CHIP RF 100 5 NPO 100V
C5855	2111078B23	CAP CHIP RF 24 5 NPO 100V
C5856	2113740B49	CAP CHIP REEL CL1 +/-30 100
C5857	2113741N45	CAP CHIP CL2 X7R 10% 10000
C5858	2113740B17	CAP CHIP REEL CL1 +/-30 4.7
C5860 thru C5862	2113740B49	CAP CHIP REEL CL1 +/-30 100
C5863	2113743G24	CAP CHIP 2.2 UF 16V +80-20%
C5864 thru C5869	2113740B49	CAP CHIP REEL CL1 +/-30 100
C5875 & C5876	2111078B32	CAP CHIP RF 39 5 NPO 100V
C5877 & C5878	2184366F08	CAP MICA 40 5 250V
C5879	-----	NOTPLACED
C5880	2111078B15	CAP CHIP RF 12 5 NPO 100V
C5881	2113740B49	CAP CHIP REEL CL1 +/-30 100
C5883	2113741N45	CAP CHIP CL2 X7R 10% 10000
C5884	2113741N69	CAP CHIP CL2 X7R 10% 100000
C5885	2380090M24	CAP ALU 10 20 50V SURF MT
C5886	2113741N21	CAP CHIP CL2 X7R 10% 1000
C5887	2111078B19	CAP CHIP RF 16 5 NPO 100V
C5888 thru C5890	2113740B49	CAP CHIP REEL CL1 +/-30 100
C5891	2113740B17	CAP CHIP REEL CL1 +/-30 4.7
C5892	2111078B13	CAP CHIP RF 10 .5 NPO 100V
C5893	2113741N45	CAP CHIP CL2 X7R 10% 10000

ITEM	MOTOROLA PART NUMBER	DESCRIPTION
C5894	-----	NOTPLACED
C5895	2113741N21	CAP CHIP CL2 X7R 10% 1000
C5900	-----	NOTPLACED
C5901 & C5902	2113740B49	CAP CHIP REEL CL1 +/-30 100
C5903	2113740B17	CAP CHIP REEL CL1 +/-30 4.7
C5904	2113740B27	CAP CHIP REEL CL1 +/-30 12
C5905	2113740B21	CAP CHIP REEL CL1 +/-30 6.8
C5906	2113740B49	CAP CHIP REEL CL1 +/-30 100
C5907	-----	NOTPLACED
C5920	2113743G24	CAP CHIP 2.2 UF 16V +80-20%
C5922	2111078B42	CAP CHIP RF 100 5 NPO 100V
C5923	2111078B05	CAP CHIP RF 4.7 .25 NPO 100V
C5924	2111078B08	CAP CHIP RF 6.2 .25 NPO 100V
C5926 & C5927	2111078B42	CAP CHIP RF 100 5 NPO 100V
C5928	2113740B34	CAP CHIP REEL CL1 +/-30 24
C5930 & C5931	2113740B49	CAP CHIP REEL CL1 +/-30 100
CR5875	4880236E07	DIODE TRANSIENT SUP
CR5900	4880236E05	DIODE HOT CAR SOT 23
CR5920 & CR5921	4880236E24	DIODE PIN
CR5922	4805119G18	DIODE SMBD1023 STEP RECOVERY
J0853	2880102M06	PLUG VERTICAL 12 POSITION
L5801	2480067M01	CHK RF CHIP BEAD INDUCTOR 28MZ
L5802	2480091G21	COIL AIRWOUND
L5805	2480091G23	COIL AIRWOUND
L5806	2480067M01	CHK RF CHIP BEAD INDUCTOR 28MZ
L5809	2480067M01	CHK RF CHIP BEAD INDUCTOR 28MZ
L5810	2484657R01	INDUCTOR BEAD CHIP
L5820 & L5821	2480091G21	COIL AIRWOUND
L5850	2480091G21	COIL AIRWOUND
L5851	2480091G23	COIL AIRWOUND
L5852	2484657R01	INDUCTOR BEAD CHIP
L5853	2480091G21	COIL AIRWOUND
L5854	2484657R01	INDUCTOR BEAD CHIP
L5875	2480091G21	COIL AIRWOUND
L5876	2480091G36	COIL AIRWOUND
L5878	2480090G03	COIL AIRWOUND
L5879	2480090G05	COIL AIRWOUND
L5883	2484657R01	INDUCTOR BEAD CHIP
L5900	2480091G06	COIL AIRWOUND
L5901	-----	NOTPLACED
L5902 & L5903	2480091G24	COIL AIRWOUND

ITEM	MOTOROLA PART NUMBER	DESCRIPTION
L5904 & L5920	2480091G36	COIL AIRWOUND
L5921 & L5922	2480090G03	COIL AIRWOUND
L5923	2480091G36	COIL AIRWOUND
P0853	0980103M04	RECEPTICAL RIGHT ANGLE 12 POS
Q5800	4880141L01	TSTR PNP SOT23 LO PROFILE TAPE
Q5801	4880182D50	TSTR SI SORF 4V 750MW 960MHZ
Q5803	4880225C09	TSTR M25C09
Q5803	2680187N02	HEATSINK, TO39
Q5806	4880141L02	TSTR NPN SOT23 LO PROFILE TAPE
Q5850	4880225C27	TSTR RF MRF654F IN CS12 PKG
Q5875	4880225C30	TSTR RF 14W/50W UHF .5 CQ
R5801	0611077A26	RES CHIP 10 5 1/8W
R5802	0611077A50	RES CHIP 100 5 1/8W
R5803	0611077A82	RES CHIP 2200 5 1/8
R5805	0611077A26	RES CHIP 10 5 1/8W
R5806	0611077A50	RES CHIP 100 5 1/8W
R5807	0611077A82	RES CHIP 2200 5 1/8
R5808	0611077A90	RES CHIP 4700 5 1/8
R5809	0611077A78	RES CHIP 1500 5 1/8
R5810	0611077A26	RES CHIP 10 5 1/8W
R5811	0611077A74	RES CHIP 1000 5 1/8
R5812	0611077A01	RES CHIP JUMPER
R5813	-----	NOTPLACED
R5816	0611077A80	RES CHIP 1800 5 1/8
R5817	0611077A74	RES CHIP 1000 5 1/8
R5818	0611077A62	RES CHIP 330 5 1/8W
R5850	0611077A10	RES CHIP 2.2 5 1/8W
R5872	0611077A50	RES CHIP 100 5 1/8W
R5873	0611077A50	RES CHIP 100 5 1/8W
R5875	1780228N01	RESISTOR SHUNT
R5876	0611077B11	RES CHIP 33K 5 1/8W
R5877	0611077A94	RES CHIP 6800 5 1/8
R5878	0611077A86	RES CHIP 3300 5 1/8
R5879 & R5880	0611077A10	RES CHIP 2.2 5 1/8W
R5881 & R5882	0611077A19	RES CHIP 5.1 5 1/8W
R5883 & R5884	0611077A10	RES CHIP 2.2 5 1/8W
R5900 & R5901	0680194M18	RES 51 OHMS 5% 1W
R5902 & R5903	-----	NOTPLACED
R5904	0611077A80	RES CHIP 1800 5 1/8
R5905	0611077B11	RES CHIP 33K 5 1/8W
R5906	0611077A50	RES CHIP 100 5 1/8W

ITEM	MOTOROLA PART NUMBER	DESCRIPTION
R5920 & R5921	0680194M18	RES 51 OHMS 5% 1W
R5922 & R5923	0611077A78	RES CHIP 1500 5 1/8
R5931 thru R5933	0611077A01	RES CHIP JUMPER
R5934	-----	NOTPLACED
RT5875 & RT5904	0680149M02	THERMISTOR CHIP 100K OHM
	8480198N34	BD CKT 40W UHF PA PNL

HLE6044C UHF R4 40-Watt PA Parts List

ITEM	MOTOROLA PART NUMBER	DESCRIPTION
C5801 & C5804	2113741N45	CAP CHIP CL2 X7R 10% 10000
C5805	2113740B21	CAP CHIP REEL CL1 +/-30 6.8
C5806	2113740B31	CAP CHIP REEL CL1 +/-30 18
C5807 & C5808	2113740B49	CAP CHIP REEL CL1 +/-30 100
C5810	2113741N69	CAP CHIP CL2 X7R 10% 100000
C5811	2113740B49	CAP CHIP REEL CL1 +/-30 100
C5813	2113741N45	CAP CHIP CL2 X7R 10% 10000
C5815 & C5816	2113740B49	CAP CHIP REEL CL1 +/-30 100
C5820 & C5821	2113740B24	CAP CHIP REEL CL1 +/-30 9.1
C5822	2113740B05	CAP CHIP REEL CL1 +/-30 1.5
C5823	2113740B21	CAP CHIP REEL CL1 +/-30 6.8
C5824	2113740B27	CAP CHIP REEL CL1 +/-30 12
C5826	2113741N45	CAP CHIP CL2 X7R 10% 10000
C5850	-----	NOTPLACED
C5851 & C5852	2113740B34	CAP CHIP REEL CL1 +/-30 24
C5853	2111078B19	CAP CHIP RF 16 5 NPO 100V
C5854	2111078B42	CAP CHIP RF 100 5 NPO 100V
C5855	2111078B22	CAP CHIP RF 22 5 NPO 100V
C5856	2113740B49	CAP CHIP REEL CL1 +/-30 100
C5857	2113741N45	CAP CHIP CL2 X7R 10% 10000
C5858	2113740B17	CAP CHIP REEL CL1 +/-30 4.7
C5860 thru C5869	2113740B49	CAP CHIP REEL CL1 +/-30 100
C5875 & C5876	2111078B32	CAP CHIP RF 39 5 NPO 100V
C5877 & C5878	2184366F08	CAP MICA 40 5 250V
C5879	-----	NOTPLACED
C5880	2111078B08	CAP CHIP RF 6.2 .25 NPO 100V

ITEM	MOTOROLA PART NUMBER	DESCRIPTION
C5881	2113740B49	CAP CHIP REEL CL1 +/-30 100
C5883	2113741N45	CAP CHIP CL2 X7R 10% 10000
C5884	2113741N69	CAP CHIP CL2 X7R 10% 100000
C5885	2380090M24	CAP ALU 10 20 50V SURF MT
C5886	2113741N21	CAP CHIP CL2 X7R 10% 1000
C5887	-----	NOTPLACED
C5888 & C5889	2113740B49	CAP CHIP REEL CL1 +/-30 100
C5890	2113740B49	CAP CHIP REEL CL1 +/-30 100
C5891	2113740B17	CAP CHIP REEL CL1 +/-30 4.7
C5892	2111078B08	CAP CHIP RF 6.2 .25 NPO 100V
C5893	2113741N45	CAP CHIP CL2 X7R 10% 10000
C5894	-----	NOTPLACED
C5895	2113741N21	CAP CHIP CL2 X7R 10% 1000
C5900	-----	NOTPLACED
C5901 & C5902	2113740B49	CAP CHIP REEL CL1 +/-30 100
C5903	2113740B17	CAP CHIP REEL CL1 +/-30 4.7
C5904	2113740B25	CAP CHIP REEL CL1 +/-30 10
C5905	2113740B21	CAP CHIP REEL CL1 +/-30 6.8
C5906	2113740B49	CAP CHIP REEL CL1 +/-30 100
C5907	-----	NOTPLACED
C5920	2113743G24	CAP CHIP 2.2 UF 16V +80-20%
C5922	2111078B42	CAP CHIP RF 100 5 NPO 100V
C5923	2111078B01	CAP CHIP RF 3.3 .25 NPO 100V
C5924	2111078B05	CAP CHIP RF 4.7 .25 NPO 100V
C5926 & C5927	2111078B42	CAP CHIP RF 100 5 NPO 100V
C5928	2113740B34	CAP CHIP REEL CL1 +/-30 24
C5930 & C5931	2113740B49	CAP CHIP REEL CL1 +/-30 100
CR5875	4880236E07	DIODE TRANSIENT SUP
CR5900	4813825A05	DIODE 30V HOT CARRIER MMBD301L
CR5920 & CR5921	4880236E24	DIODE PIN
CR5922	4805119G18	DIODE SMBD1023 STEP RECOVERY
J0853	2880102M06	PLUG VERTICAL 12 POSITION
L5801	2480067M01	CHK RF CHIP BEAD INDUCTOR 28MZ
L5802	2480091G21	COIL AIRWOUND
L5805	2480091G23	COIL AIRWOUND
L5806 & L5809	2480067M01	CHK RF CHIP BEAD INDUCTOR 28MZ
L5810	2484657R01	INDUCTOR BEAD CHIP
L5820, L5821 & L5850	2480091G21	COIL AIRWOUND
L5851	2480091G23	COIL AIRWOUND
L5852	2484657R01	INDUCTOR BEAD CHIP

ITEM	MOTOROLA PART NUMBER	DESCRIPTION
L5853	2480091G21	COIL AIRWOUND
L5854	2484657R01	INDUCTOR BEAD CHIP
L5875	2480091G21	COIL AIRWOUND
L5876	2480091G36	COIL AIRWOUND
L5878	2480090G03	COIL AIRWOUND
L5879	2480090G05	COIL AIRWOUND
L5883	2484657R01	INDUCTOR BEAD CHIP
L5900	2480091G06	COIL AIRWOUND
L5901	-----	NOTPLACED
L5902 & L5903	2480091G24	COIL AIRWOUND
L5904 & L5920	2480091G36	COIL AIRWOUND
L5921 & L5922	2480090G03	COIL AIRWOUND
L5923	2480091G36	COIL AIRWOUND
MP5801 thru MP5803	2980014A03	CLIP COAX TERMINAL
P0853	0980103M04	RECEPTICAL RIGHT ANGLE 12 POS
Q5800	4880141L01	TSTR PNP SOT23 LO PROFILE TAPE
Q5801	4880182D50	TSTR SI SORF 4V 750MW 960MHZ
Q5803	4880225C09	TSTR M25C09
Q5806	4880141L02	TSTR NPN SOT23 LO PROFILE TAPE
Q5850	4880225C27	TSTR RF MRF654F IN CS12 PKG
Q5875	4880225C30	TSTR RF 14W/50W UHF .5 CQ
R5801	0611077A30	RES CHIP 15 5 1/8W
R5802	0611077A50	RES CHIP 100 5 1/8W
R5803	0611077A82	RES CHIP 2200 5 1/8
R5805	0611077A26	RES CHIP 10 5 1/8W
R5806	0611077A50	RES CHIP 100 5 1/8W
R5807	0611077A82	RES CHIP 2200 5 1/8
R5808	0611077A90	RES CHIP 4700 5 1/8
R5809	0611077A78	RES CHIP 1500 5 1/8
R5810	0611077A26	RES CHIP 10 5 1/8W
R5811	0611077A74	RES CHIP 1000 5 1/8
R5812	0611077A01	RES CHIP JUMPER
R5813	-----	NOTPLACED
R5816	0611077A80	RES CHIP 1800 5 1/8
R5817	0611077A74	RES CHIP 1000 5 1/8
R5818	0611077A62	RES CHIP 330 5 1/8W
R5850	0611077A10	RES CHIP 2.2 5 1/8W
R5872 & R5873	0611077A50	RES CHIP 100 5 1/8W
R5875	1780228N01	RESISTOR SHUNT
R5876	0611077B11	RES CHIP 33K 5 1/8W
R5877	0611077A94	RES CHIP 6800 5 1/8
R5878	0611077A86	RES CHIP 3300 5 1/8

ITEM	MOTOROLA PART NUMBER	DESCRIPTION
R5879	0611077A10	RES CHIP 2.2 5 1/8W
R5880	0611077A10	RES CHIP 2.2 5 1/8W
R5881	0611077A19	RES CHIP 5.1 5 1/8W
R5882	0611077A19	RES CHIP 5.1 5 1/8W
R5883 & R5884	0611077A10	RES CHIP 2.2 5 1/8W
R5900 & R5901	0680194M18	RES 51 OHMS 5% 1W
R5902 & R5903	-----	NOTPLACED
R5904	0611077A80	RES CHIP 1800 5 1/8
R5905	0611077B11	RES CHIP 33K 5 1/8W
R5906	0611077A50	RES CHIP 100 5 1/8W
R5920 & R5921	0680194M18	RES 51 OHMS 5% 1W
R5922 & R5923	0611077A78	RES CHIP 1500 5 1/8
R5931 & R5932	0611077A01	RES CHIP JUMPER
R5933	-----	NOTPLACED
R5934	0611077A01	RES CHIP JUMPER
RT5875 & RT5904	0680149M02	THERMISTOR CHIP 100K OHM
	8480198N34	BD CKT 40W UHF PA PNL

HLE6049B UHF R1 40-Watt PA Parts List

ITEM	MOTOROLA PART NUMBER	DESCRIPTION
C5801 & C5804	2113741N45	CAP CHIP CL2 X7R 10% 10000
C5805	2113740B24	CAP CHIP REEL CL1 +/-30 9.1
C5806	2113740B34	CAP CHIP REEL CL1 +/-30 24
C5807 & C5808	2113740B49	CAP CHIP REEL CL1 +/-30 100
C5810	2113741N69	CAP CHIP CL2 X7R 10% 100000
C5811	2113740B49	CAP CHIP REEL CL1 +/-30 100
C5813	2113741N45	CAP CHIP CL2 X7R 10% 10000
C5815	2113740B49	CAP CHIP REEL CL1 +/-30 100
C5816	2113743G24	CAP CHIP 2.2 UF 16V +80-20%
C5820	2113740B27	CAP CHIP REEL CL1 +/-30 12
C5821	2113740B28	CAP CHIP REEL CL1 +/-30 13
C5822	2113740B07	CAP CHIP REEL CL1 +/-30 1.8
C5823	2113740B24	CAP CHIP REEL CL1 +/-30 9.1
C5824	2113740B28	CAP CHIP REEL CL1 +/-30 13
C5826	2113741N45	CAP CHIP CL2 X7R 10% 10000
C5850	2113740B11	CAP CHIP REEL CL1 +/-30 2.7
C5851	2113740B39	CAP CHIP REEL CL1 +/-30 39
C5852	2113740B35	CAP CHIP REEL CL1 +/-30 27
C5853	-----	NOTPLACED
C5854	2111078B42	CAP CHIP RF 100 5 NPO 100V

ITEM	MOTOROLA PART NUMBER	DESCRIPTION
C5855	2111078B27	CAP CHIP RF 30 5 NPO 100V
C5856	2113740B49	CAP CHIP REEL CL1 +/-30 100
C5857	2113741N45	CAP CHIP CL2 X7R 10% 10000
C5858	2113740B17	CAP CHIP REEL CL1 +/-30 4.7
C5860 & C5861	2113740B49	CAP CHIP REEL CL1 +/-30 100
C5862	2113740B49	CAP CHIP REEL CL1 +/-30 100
C5863	2113743G24	CAP CHIP 2.2 UF 16V +80-20%
C5864	2113740B49	CAP CHIP REEL CL1 +/-30 100 thru
C5869		
C5875 & C5876	2111078B32	CAP CHIP RF 39 5 NPO 100V
C5877 & C5878	2184366F08	CAP MICA 40 5 250V
C5879	-----	NOTPLACED
C5880	2111078B22	CAP CHIP RF 22 5 NPO 100V
C5881	2113740B49	CAP CHIP REEL CL1 +/-30 100
C5883	2113741N45	CAP CHIP CL2 X7R 10% 10000
C5884	2113741N69	CAP CHIP CL2 X7R 10% 100000
C5885	2380090M24	CAP ALU 10 20 50V SURF MT
C5886	2113741N21	CAP CHIP CL2 X7R 10% 1000
C5887	2111078B22	CAP CHIP RF 22 5 NPO 100V
C5888 & C5889	2113740B49	CAP CHIP REEL CL1 +/-30 100
C5890	2113740B49	CAP CHIP REEL CL1 +/-30 100
C5891	2113740B24	CAP CHIP REEL CL1 +/-30 9.1
C5892	2111078B15	CAP CHIP RF 12 5 NPO 100V
C5893	2113741N45	CAP CHIP CL2 X7R 10% 10000
C5894	-----	NOTPLACED
C5895	2113741N21	CAP CHIP CL2 X7R 10% 1000
C5900	-----	NOTPLACED
C5901	2113740B49	CAP CHIP REEL CL1 +/-30 100
C5902	-----	NOTPLACED
C5903	2113740B17	CAP CHIP REEL CL1 +/-30 4.7
C5904	2113740B28	CAP CHIP REEL CL1 +/-30 13
C5905	2113740B21	CAP CHIP REEL CL1 +/-30 6.8
C5906	2113740B49	CAP CHIP REEL CL1 +/-30 100
C5920	2113743G24	CAP CHIP 2.2 UF 16V +80-20%
C5922	2111078B42	CAP CHIP RF 100 5 NPO 100V
C5923	2111078B01	CAP CHIP RF 3.3 .25 NPO 100V
C5924	2111078B08	CAP CHIP RF 6.2 .25 NPO 100V
C5926 & C5927	2111078B42	CAP CHIP RF 100 5 NPO 100V
C5928	2113740B34	CAP CHIP REEL CL1 +/-30 24
C5930 & C5931	2113740B49	CAP CHIP REEL CL1 +/-30 100
CR5875	4880236E07	DIODE TRANSIENT SUP
CR5900	4813825A05	DIODE 30V HOT CARRIER MMBD301L
CR5920 & CR5921	4880236E24	DIODE PIN

ITEM	MOTOROLA PART NUMBER	DESCRIPTION
CR5922	4805119G18	DIODE SMBD1023 STEP RECOVERY
E5803	2680187N02	HEATSINK, TO39
E5920	2680188N02	SHLD HAR FILTER FENCE TIN PLAT
E5922	2880102M06	PLUG VERTICAL 12 POSITION
L5801	2480067M01	CHK RF CHIP BEAD INDUCTOR 28MZ
L5802	2480091G21	COIL AIRWOUND
L5805	2480091G23	COIL AIRWOUND
L5806 & L5809	2480067M01	CHK RF CHIP BEAD INDUCTOR 28MZ
L5810	2484657R01	INDUCTOR BEAD CHIP
L5820, L5821 & L5850	2480091G21	COIL AIRWOUND
L5851	2480091G23	COIL AIRWOUND
L5852	2484657R01	INDUCTOR BEAD CHIP
L5853	2480091G21	COIL AIRWOUND
L5854	2484657R01	INDUCTOR BEAD CHIP
L5875	2480091G21	COIL AIRWOUND
L5876	2480091G36	COIL AIRWOUND
L5878	2480090G03	COIL AIRWOUND
L5879	2480090G05	COIL AIRWOUND
L5883	2484657R01	INDUCTOR BEAD CHIP
L5900 & L5901	-----	NOTPLACED
L5902 & L5903	2480091G24	COIL AIRWOUND
L5904 & L5920	2480091G36	COIL AIRWOUND
L5921	2480090G04	COIL AIRWOUND
L5922	2480090G18	COIL AIRWOUND
L5923	2480091G36	COIL AIRWOUND
MP5801 thru MP5803	2980014A03	CLIP COAX TERMINAL
P0853	0980103M04	RECEPTICAL RIGHT ANGLE 12 POS
Q5800	4880141L01	TSTR PNP SOT23 LO PROFILE TAPE
Q5801	4880182D50	TSTR SI SORF 4V 750MW 960MHZ
Q5803	4880225C09	TSTR M25C09
Q5806	4880141L02	TSTR NPN SOT23 LO PROFILE TAPE
Q5850	4880225C27	TSTR RF MRF654F IN CS12 PKG
Q5875	4880225C30	TSTR RF 14W/50W UHF .5 CQ
R5801	0611077A30	RES CHIP 15 5 1/8W
R5802	0611077A50	RES CHIP 100 5 1/8W
R5803	0611077A82	RES CHIP 2200 5 1/8
R5805	0611077A26	RES CHIP 10 5 1/8W

ITEM	MOTOROLA PART NUMBER	DESCRIPTION
R5806	0611077A50	RES CHIP 100 5 1/8W
R5807	0611077A82	RES CHIP 2200 5 1/8
R5808	0611077A90	RES CHIP 4700 5 1/8
R5809	0611077A78	RES CHIP 1500 5 1/8
R5810	0611077A26	RES CHIP 10 5 1/8W
R5811	0611077A74	RES CHIP 1000 5 1/8
R5812	0611077A01	RES CHIP JUMPER
R5813	-----	NOTPLACED
R5816	0611077A80	RES CHIP 1800 5 1/8
R5817	0611077A74	RES CHIP 1000 5 1/8
R5818	0611077A62	RES CHIP 330 5 1/8W
R5850	0611077A10	RES CHIP 2.2 5 1/8W
R5872 & R5873	0611077A50	RES CHIP 100 5 1/8W
R5875	1780228N01	RESISTOR SHUNT
R5876	0611077B11	RES CHIP 33K 5 1/8W
R5877	0611077A94	RES CHIP 6800 5 1/8
R5878	0611077A86	RES CHIP 3300 5 1/8
R5879 & R5880	0611077A10	RES CHIP 2.2 5 1/8W
R5881 & R5882	0611077A19	RES CHIP 5.1 5 1/8W
R5883 & R5884	0611077A10	RES CHIP 2.2 5 1/8W
R5900 & R5901	0680194M18	RES 51 OHMS 5% 1W
R5902 & R5903	-----	NOTPLACED
R5904	0611077A80	RES CHIP 1800 5 1/8
R5905	0611077B11	RES CHIP 33K 5 1/8W
R5906	0611077A50	RES CHIP 100 5 1/8W
R5907	0611077A36	RES CHIP 27 5 1/8W
R5920 & R5921	0680194M18	RES 51 OHMS 5% 1W
R5922 & R5923	0611077A78	RES CHIP 1500 5 1/8
R5931	0611077A01	RES CHIP JUMPER
R5932	-----	NOTPLACED
R5933 & R5934	0611077A01	RES CHIP JUMPER
RT5875	0680149M02	THERMISTOR CHIP 100K OHM
RT5904	0680149M02	THERMISTOR CHIP 100K OHM
	4280120P01	CLIP RECEIVE GROUND
	8480198N34	BD CKT 40W UHF PA PNL

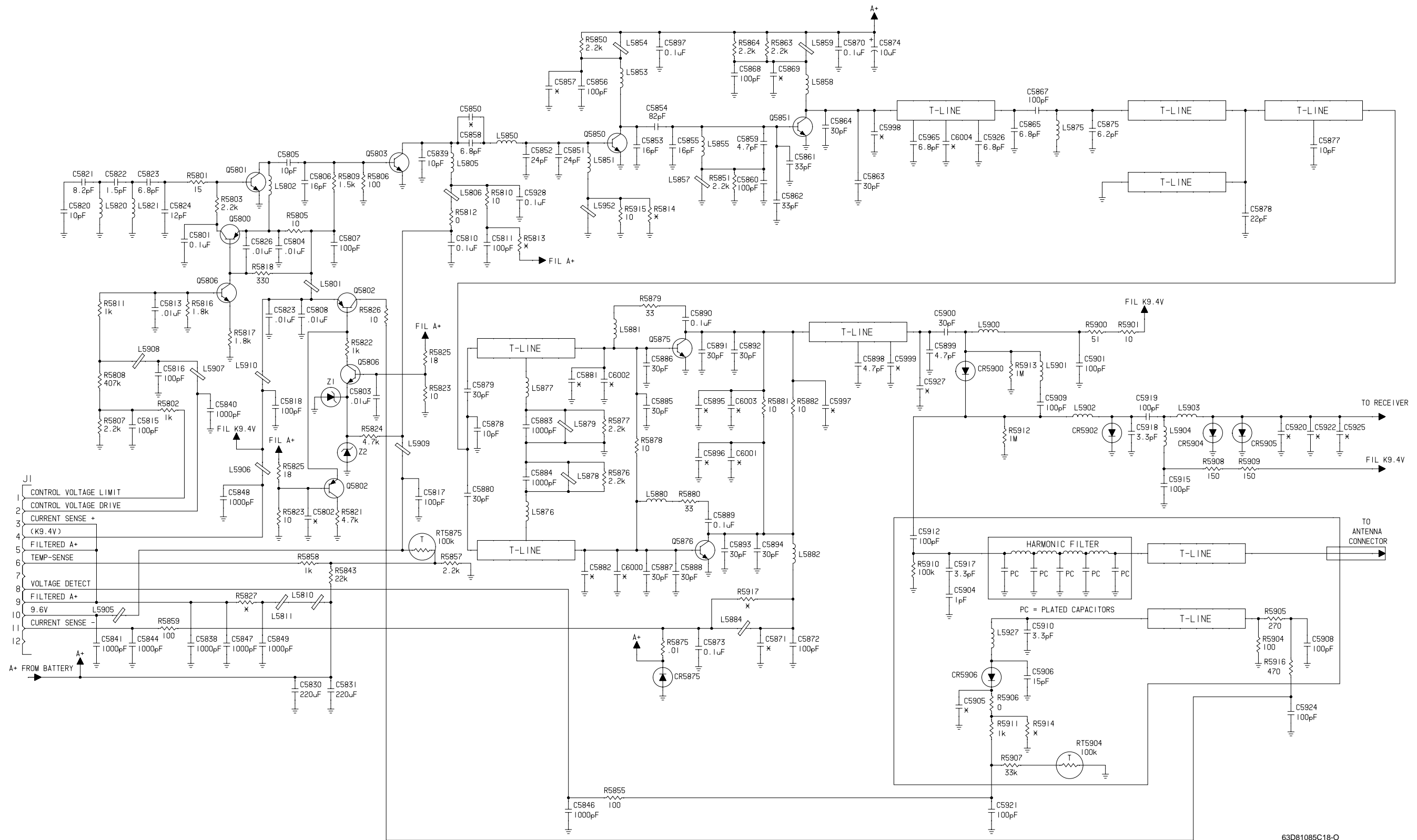

HLE6039C, HLE6040C, and HLE6051C UHF 100-Watt PA Schematic

VIEWED FROM SIDE 1

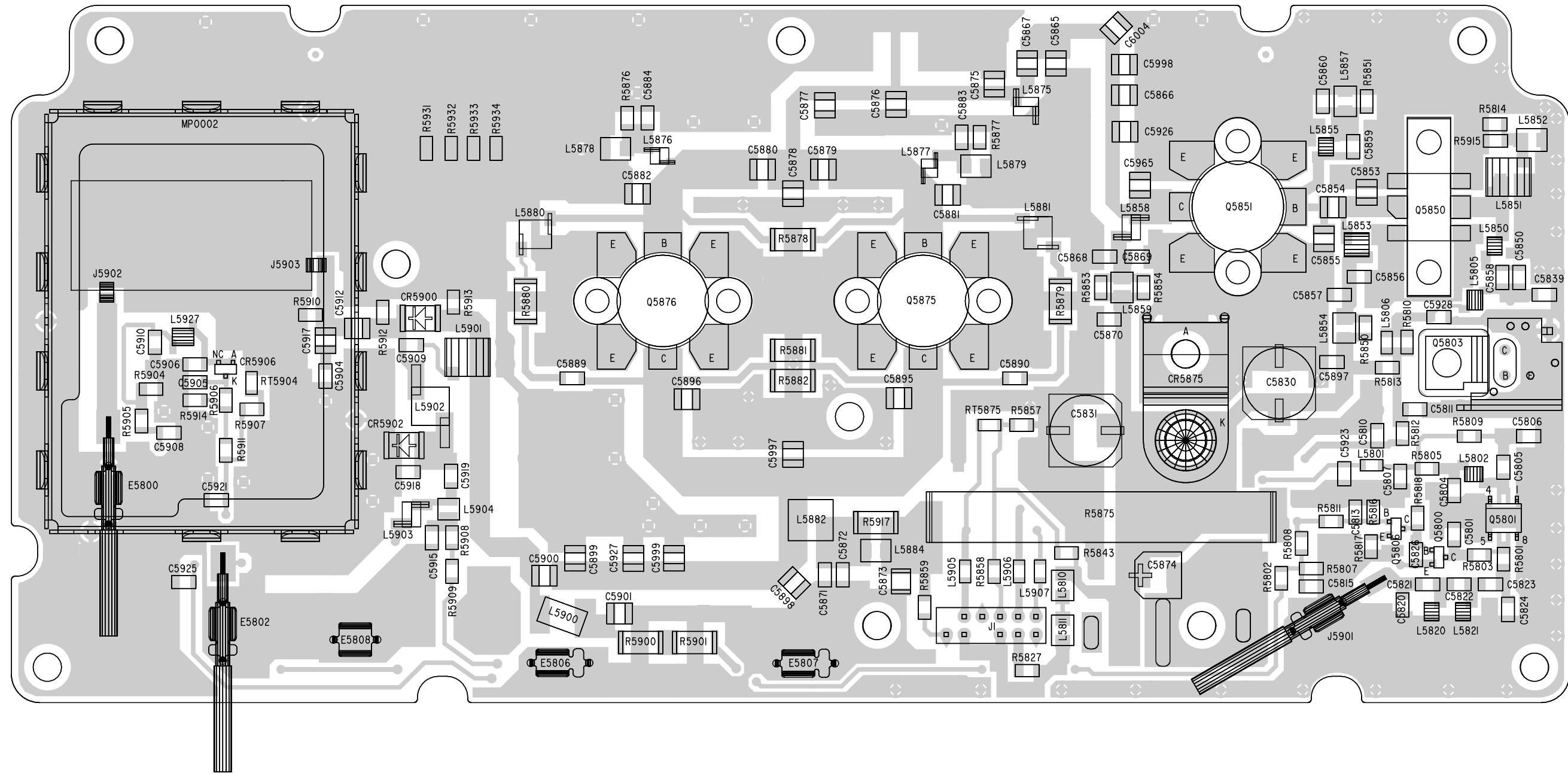

HLE6039C, HLE6040C, and HLE6051C UHF 100-Watt PA Component Location Diagram, Side 1

VIEWED FROM SIDE 2

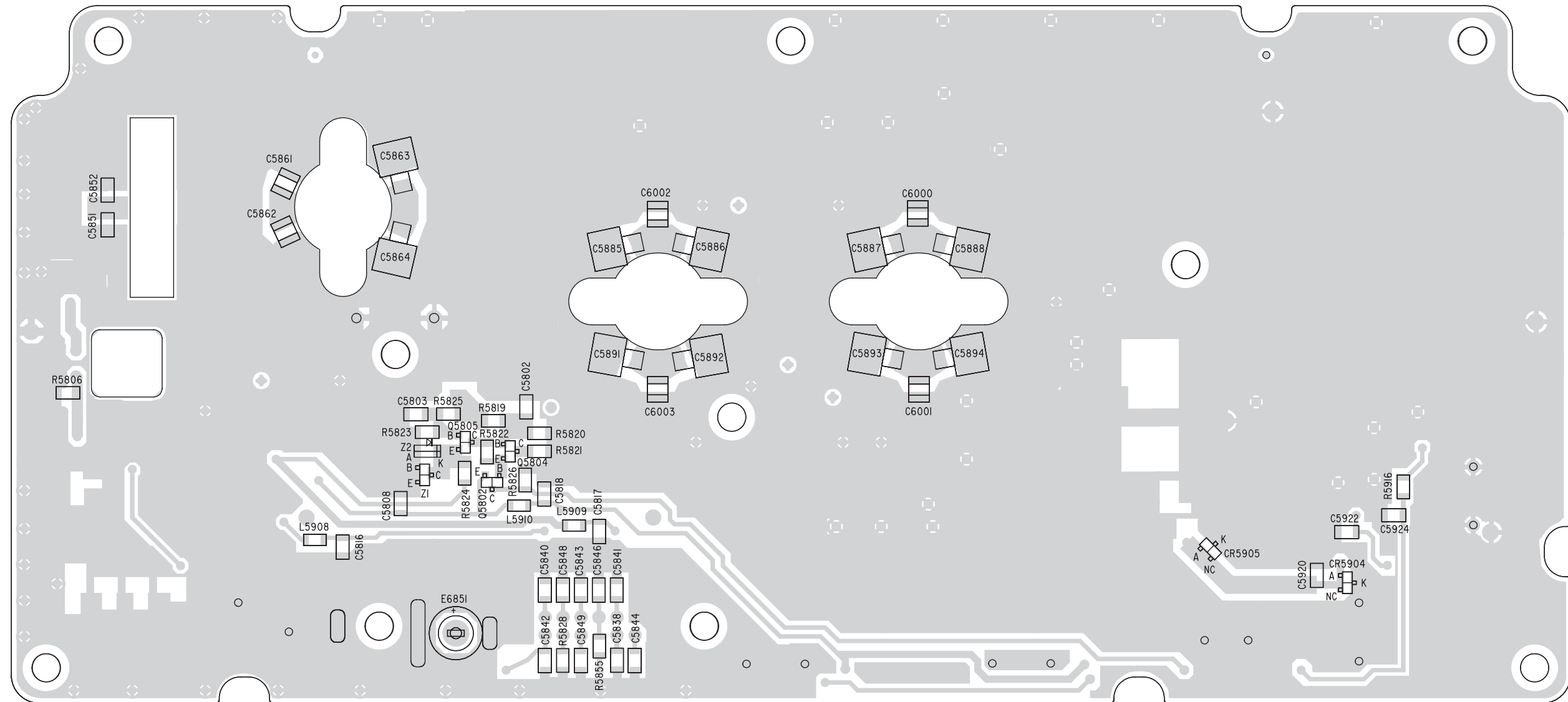

HLE6039C, HLE6040C, and HLE6051C UHF 100-Watt PA Component Location Diagram, Side 2

HLE6039C UHF R3 100-Watt PA Parts List

ITEM	MOTOROLA PART NUMBER	DESCRIPTION
C5801	2113741N69	CAP CHIP CL2 X7R 10% 100000
C5804	2113741N45	CAP CHIP CL2 X7R 10% 10000
C5805	2113740B25	CAP CHIP REEL CL1 +/-30 10
C5806	2113740B30	CAP CHIP REEL CL1 +/-30 16
C5807	2113740B49	CAP CHIP REEL CL1 +/-30 100
C5808	2113741N45	CAP CHIP CL2 X7R 10% 10000
C5810	2113741N69	CAP CHIP CL2 X7R 10% 100000
C5811	2113740B49	CAP CHIP REEL CL1 +/-30 100
C5813	2113741N45	CAP CHIP CL2 X7R 10% 10000
C5815 thru C5818	2113740B49	CAP CHIP REEL CL1 +/-30 100
C5820	2113740B27	CAP CHIP REEL CL1 +/-30 12
C5821	2113740B23	CAP CHIP REEL CL1 +/-30 8.2
C5822	2113740B05	CAP CHIP REEL CL1 +/-30 1.5
C5823	2113740B21	CAP CHIP REEL CL1 +/-30 6.8
C5824	2113740B27	CAP CHIP REEL CL1 +/-30 12
C5826	2113741N45	CAP CHIP CL2 X7R 10% 10000
C5830 & C5831	2380090M32	CAP ALU 220 20 35V
C5838	2113740B73	CAP CHIP REEL CL1 +/-30 1000
C5839	2113740B25	CAP CHIP REEL CL1 +/-30 10
C5840 thru C5844	2113740B73	CAP CHIP REEL CL1 +/-30 1000
C5846	2113740B73	CAP CHIP REEL CL1 +/-30 1000
C5848 & C5849	2113740B73	CAP CHIP REEL CL1 +/-30 1000
C5851 & C5852	2113740B34	CAP CHIP REEL CL1 +/-30 24
C5853	2111078B19	CAP CHIP RF 16 5 NPO 100V
C5854	2111078B40	CAP CHIP RF 82 5 NPO 100V
C5855	2111078B19	CAP CHIP RF 16 5 NPO 100V
C5856	2113740B49	CAP CHIP REEL CL1 +/-30 100
C5858	2113740B21	CAP CHIP REEL CL1 +/-30 6.8
C5859	2113740B17	CAP CHIP REEL CL1 +/-30 4.7
C5860	2113740B49	CAP CHIP REEL CL1 +/-30 100
C5861 & C5862	2111078B29	CAP CHIP RF 33 5 NPO 100V
C5863 & C5864	2184366F43	CAP MICA 30 5 250V
C5865	2111078B07	CAP CHIP RF 5.6 .25 NPO 100V
C5867	2111078B42	CAP CHIP RF 100 5 NPO 100V
C5868	2113740B49	CAP CHIP REEL CL1 +/-30 100
C5870	2113741N69	CAP CHIP CL2 X7R 10% 100000
C5872	2113740B49	CAP CHIP REEL CL1 +/-30 100
C5873	2113741N69	CAP CHIP CL2 X7R 10% 100000
C5874	2380090M24	CAP ALU 10 20 50V SURF MT
C5875	2111078B08	CAP CHIP RF 6.2 .25 NPO 100V
C5876	2111078B22	CAP CHIP RF 22 5 NPO 100V

ITEM	MOTOROLA PART NUMBER	DESCRIPTION
C5877 & C5878	2111078B13	CAP CHIP RF 10 .5 NPO 100V
C5879 & C5880	2111078B27	CAP CHIP RF 30 5 NPO 100V
C5883 & C5884	2113740B73	CAP CHIP REEL CL1 +/-30 1000
C5885 thru C5888	2184366F43	CAP MICA 30 5 250V
C5889 & C5890	2113741N69	CAP CHIP CL2 X7R 10% 100000
C5891 thru C5894	2184366F43	CAP MICA 30 5 250V
C5897	2113741N69	CAP CHIP CL2 X7R 10% 100000
C5898	-----	NOTPLACED
C5899	2113742B18	CAP CER 4.7 PF +.25PF
C5900	2111078B27	CAP CHIP RF 30 5 NPO 100V
C5901	2111078B42	CAP CHIP RF 100 5 NPO 100V
C5904	2113740B01	CAP CHIP REEL CL1 +/-30 1.0
C5905	2113740B49	CAP CHIP REEL CL1 +/-30 100
C5906	2113740B29	CAP CHIP REEL CL1 +/-30 15
C5908	2113740B49	CAP CHIP REEL CL1 +/-30 100
C5909	2113740B49	CAP CHIP REEL CL1 +/-30 100
C5910	2113740B13	CAP CHIP REEL CL1 +/-30 3.3
C5912	2111078B42	CAP CHIP RF 100 5 NPO 100V
C5915	2113740B49	CAP CHIP REEL CL1 +/-30 100
C5917	2111078B01	CAP CHIP RF 3.3 .25 NPO 100V
C5918	2113740B13	CAP CHIP REEL CL1 +/-30 3.3
C5919 & C5921	2113740B49	CAP CHIP REEL CL1 +/-30 100
C5923	2113741N45	CAP CHIP CL2 X7R 10% 10000
C5924	2113740B49	CAP CHIP REEL CL1 +/-30 100
C5926	2111078B09	CAP CHIP RF 6.8 .25 NPO 100V
C5928	2113741N69	CAP CHIP CL2 X7R 10% 100000
C5965	2111078B09	CAP CHIP RF 6.8 .25 NPO 100V
C5997	2113742B22	CAP CER 10.0 PF .50 PF
CR5875	4880222R01	DIODE REVERSE POLARITY SPECTRA
CR5900 & CR5902	4880121R01	PWR PIN DIODE SMD TAPE & REEL
CR5904 & CR5905	4805656W04	DIODE SOT 23 PIN
CR5906	4813825A05	DIODE 30V HOT CARRIER MMBD301L
E5800 & E5802	4280088P01	CLIP COAX
E5803	2680187N02	HEATSINK, TO39
E5804	2680201R02	HEATSINK DIODE TIN PLATED
E5806	4280088P01	CLIP COAX
E5807	4280088P01	CLIP COAX

ITEM	MOTOROLA PART NUMBER	DESCRIPTION
E5808	4280202R02	CLIP COAX TIN PLATED
J0001	2880102M11	PLUG VERTICAL 12 POS
J5901	4280088P01	CLIP COAX
L5801	2480067M01	CHK RF CHIP BEAD INDUCTOR 28MZ
L5802	2480091G21	COIL AIRWOUND
L5805	2480091G23	COIL AIRWOUND
L5806	2480067M01	CHK RF CHIP BEAD INDUCTOR 28MZ
L5810 & L5811	2484657R01	INDUCTOR BEAD CHIP
L5820, L5821 & L5850	2480091G21	COIL AIRWOUND
L5851	2480091G23	COIL AIRWOUND
L5852	2484657R01	INDUCTOR BEAD CHIP
L5853	2480090G03	COIL AIRWOUND
L5854	2484657R01	INDUCTOR BEAD CHIP
L5855	2480091G21	COIL AIRWOUND
L5857	2484657R01	INDUCTOR BEAD CHIP
L5858	2480090G03	COIL AIRWOUND
L5859	2484657R01	INDUCTOR BEAD CHIP
L5875	2480090G03	COIL AIRWOUND
L5876 & L5877	2480091G21	COIL AIRWOUND
L5878 & L5879	2484657R01	INDUCTOR BEAD CHIP
L5880 & L5881	2480091G36	COIL AIRWOUND
L5882	2480090G10	COIL AIRWOUND
L5884	2484657R01	INDUCTOR BEAD CHIP
L5900	2480090G13	COIL AIRWOUND
L5901	2480090G16	COIL AIRWOUND RF 000.000
L5902	2480090G19	COIL AIRWOUND
L5903	2480090G03	COIL AIRWOUND
L5904	2480140E11	INDUCTOR CHIP 360 NH
L5905	2480067M01	CHK RF CHIP BEAD INDUCTOR 28MZ
L5906 thru L5910	2480067M01	CHK RF CHIP BEAD INDUCTOR 28MZ
L5927	2480091G24	COIL AIRWOUND
MP0002	2680139P02	SHLD HAR FLTR TIN PLATED
Q5800	4880141L01	TSTR PNP SOT23 LO PROFILE TAPE
Q5801	4880182D50	TSTR SI SORF 4V 750MW 960MHZ
Q5802	4880141L01	TSTR PNP SOT23 LO PROFILE TAPE
Q5803	4880225C09	TSTR M25C09
Q5804	4880141L01	TSTR PNP SOT23 LO PROFILE TAPE

ITEM	MOTOROLA PART NUMBER	DESCRIPTION
Q5805 & Q5806	4880141L02	TSTR NPN SOT23 LO PROFILE TAPE
Q5850	4880225C27	TSTR RF MRF654F IN CS12 PKG
Q5851	4880225C30	TSTR RF 14W/50W UHF .5 CQ
Q5875 & Q5876	4880225C29	TSTR RF MRF658 IN FLANGE PKG
R5801	0611077A30	RES CHIP 15 5 1/8W
R5802	0611077A74	RES CHIP 1000 5 1/8
R5803	0611077A82	RES CHIP 2200 5 1/8
R5805	0611077A26	RES CHIP 10 5 1/8W
R5806	0611077A50	RES CHIP 100 5 1/8W
R5807	0611077A82	RES CHIP 2200 5 1/8
R5808	0611077A90	RES CHIP 4700 5 1/8
R5809	0611077A78	RES CHIP 1500 5 1/8
R5810	0611077A26	RES CHIP 10 5 1/8W
R5811	0611077A74	RES CHIP 1000 5 1/8
R5812	0611077A01	RES CHIP JUMPER
R5816	0611077A80	RES CHIP 1800 5 1/8
R5817	0611077A74	RES CHIP 1000 5 1/8
R5818	0611077A62	RES CHIP 330 5 1/8W
R5819	0611077A86	RES CHIP 3300 5 1/8
R5820	0611077B01	RES CHIP 12K 5 1/8W
R5821	0611077A90	RES CHIP 4700 5 1/8
R5822	0611077A74	RES CHIP 1000 5 1/8
R5823	0611077A98	RES CHIP 10K 5 1/8W
R5824	0611077A90	RES CHIP 4700 5 1/8
R5825	0611077B05	RES CHIP 18K 5 1/8W
R5826	0611077A68	RES CHIP 560 5 1/8W
R5827	0611077A50	RES CHIP 100 5 1/8W
R5828	0611077B15	RES CHIP 47K 5 1/8W
R5843	0611077B07	RES CHIP 22K 5 1/8W
R5850 & R5851	0611077A10	RES CHIP 2.2 5 1/8W
R5853 & R5854	0611077A10	RES CHIP 2.2 5 1/8W
R5855	0611077A74	RES CHIP 1000 5 1/8
R5857	0611077A82	RES CHIP 2200 5 1/8
R5858	0611077A74	RES CHIP 1000 5 1/8
R5859	0611077A50	RES CHIP 100 5 1/8W
R5875	1780165C02	RES SHUNT
R5876 & R5877	0611077A10	RES CHIP 2.2 5 1/8W
R5878	0680194M01	RES 10 OHMS 5% 1W
R5879 & R5880	0680194M13	RES 33 OHMS 5% 1W
R5881 & R5882	0680194M01	RES 10 OHMS 5% 1W
R5900	0680194M18	RES 51 OHMS 5% 1W
R5901	0680194M01	RES 10 OHMS 5% 1W
R5904	0611077A50	RES CHIP 100 5 1/8W
R5905	0611077A60	RES CHIP 270 5 1/8W
R5906	0611077A01	RES CHIP JUMPER

ITEM	MOTOROLA PART NUMBER	DESCRIPTION
R5907	0611077B11	RES CHIP 33K 5 1/8W
R5908 & R5909	0611077A54	RES CHIP 150 5 1/8W
R5910	0611077B23	RES CHIP 100K 5 1/8W
R5911	0611077A74	RES CHIP 1000 5 1/8
R5912 & R5913	0611077B47	RES CHIP 1 MEG 5 1/8W
R5914	0611077A90	RES CHIP 4700 5 1/8
R5915	0611077A26	RES CHIP 10 5 1/8W
R5916	0611077A66	RES CHIP 470 5 1/8W
RT5875 & RT5904	0680149M02	THERMISTOR CHIP 100K OHM
Z1	4813830A14	DIODE 5.1V 5% 225MW MMBZ5231B_

HLE6040C UHF R4 100-Watt PA Parts List

ITEM	MOTOROLA PART NUMBER	DESCRIPTION
C5801	2113741N69	CAP CHIP CL2 X7R 10% 100000
C5804	2113741N45	CAP CHIP CL2 X7R 10% 10000
C5805	2113740B25	CAP CHIP REEL CL1 +/-30 10
C5806	2113740B27	CAP CHIP REEL CL1 +/-30 12
C5807	2113740B49	CAP CHIP REEL CL1 +/-30 100
C5808	2113741N45	CAP CHIP CL2 X7R 10% 10000
C5810	2113741N69	CAP CHIP CL2 X7R 10% 100000
C5811	2113740B49	CAP CHIP REEL CL1 +/-30 100
C5813	2113741N45	CAP CHIP CL2 X7R 10% 10000
C5815 thru C5818	2113740B49	CAP CHIP REEL CL1 +/-30 100
C5820	2113740B24	CAP CHIP REEL CL1 +/-30 9.1
C5820	2113740B21	CAP CHIP REEL CL1 +/-30 6.8
C5821	2113740B23	CAP CHIP REEL CL1 +/-30 8.2
C5822	2113740B17	CAP CHIP REEL CL1 +/-30 4.7
C5823	2113740B23	CAP CHIP REEL CL1 +/-30 8.2
C5824	2113740B21	CAP CHIP REEL CL1 +/-30 6.8
C5826	2113741N45	CAP CHIP CL2 X7R 10% 10000
C5830 & C5831	2380090M32	CAP ALU 220 20 35V
C5838	2113740B73	CAP CHIP REEL CL1 +/-30 1000
C5839	2113740B24	CAP CHIP REEL CL1 +/-30 9.1
C5840 thru C5844	2113740B73	CAP CHIP REEL CL1 +/-30 1000
C5846	2113740B73	CAP CHIP REEL CL1 +/-30 1000
C5848 & C5849	2113740B73	CAP CHIP REEL CL1 +/-30 1000
C5851	2113740B34	CAP CHIP REEL CL1 +/-30 24
C5852	2113740B34	CAP CHIP REEL CL1 +/-30 24
C5853	2111078B21	CAP CHIP RF 20 5 NPO 100V
C5854	2111078B42	CAP CHIP RF 100 5 NPO 100V

ITEM	MOTOROLA PART NUMBER	DESCRIPTION
C5855	2111078B22	CAP CHIP RF 22 5 NPO 100V
C5856	2113740B49	CAP CHIP REEL CL1 +/-30 100
C5858	2113740B21	CAP CHIP REEL CL1 +/-30 6.8
C5859	2113740B17	CAP CHIP REEL CL1 +/-30 4.7
C5860	2113740B49	CAP CHIP REEL CL1 +/-30 100
C5861 & C5862	2111078B23	CAP CHIP RF 24 5 NPO 100V
C5863 & C5864	2113742B27	CAP CER 27.0 PF 5% PF
C5865	2111078B05	CAP CHIP RF 4.7 .25 NPO 100V
C5866	2111078B15	CAP CHIP RF 12 5 NPO 100V
C5867	2111078B42	CAP CHIP RF 100 5 NPO 100V
C5868	2113740B49	CAP CHIP REEL CL1 +/-30 100
C5870	2113741N69	CAP CHIP CL2 X7R 10% 100000
C5872	2113740B49	CAP CHIP REEL CL1 +/-30 100
C5873	2113741N69	CAP CHIP CL2 X7R 10% 100000
C5874	2380090M24	CAP ALU 10 20 50V SURF MT
C5875	2111078B08	CAP CHIP RF 6.2 .25 NPO 100V
C5876	2111078B22	CAP CHIP RF 22 5 NPO 100V
C5877	2111078B13	CAP CHIP RF 10 .5 NPO 100V
C5878	2111078B15	CAP CHIP RF 12 5 NPO 100V
C5879 & C5880	2111078B27	CAP CHIP RF 30 5 NPO 100V
C5883 & C5884	2113740B73	CAP CHIP REEL CL1 +/-30 1000
C5885 thru C5888	2113742B27	CAP CER 27.0 PF 5% PF
C5889	2113741N69	CAP CHIP CL2 X7R 10% 100000
C5890	2113741N69	CAP CHIP CL2 X7R 10% 100000
C5891 thru C5894	2113742B27	CAP CER 27.0 PF 5% PF
C5897	2113741N69	CAP CHIP CL2 X7R 10% 100000
C5898	2113742B17	CAP CER 3.9 PF +/- .25PF
C5898	2113742B18	CAP CER 4.7 PF +/- .25PF
C5900	2111078B27	CAP CHIP RF 30 5 NPO 100V
C5901	2111078B42	CAP CHIP RF 100 5 NPO 100V
C5904	2113740B01	CAP CHIP REEL CL1 +/-30 1.0
C5905	2113740B49	CAP CHIP REEL CL1 +/-30 100
C5906	2113740B29	CAP CHIP REEL CL1 +/-30 15
C5908 & C5909	2113740B49	CAP CHIP REEL CL1 +/-30 100
C5910	2113740B11	CAP CHIP REEL CL1 +/-30 2.7
C5912	2111078B42	CAP CHIP RF 100 5 NPO 100V
C5915	2113740B49	CAP CHIP REEL CL1 +/-30 100
C5917	2111078B01	CAP CHIP RF 3.3 .25 NPO 100V
C5918	2113740B11	CAP CHIP REEL CL1 +/-30 2.7
C5919 & C5921	2113740B49	CAP CHIP REEL CL1 +/-30 100
C5923	2113741N45	CAP CHIP CL2 X7R 10% 10000
C5924	2113740B49	CAP CHIP REEL CL1 +/-30 100

ITEM	MOTOROLA PART NUMBER	DESCRIPTION
C5925	2113740B73	CAP CHIP REEL CL1 +/-30 1000
C5926	2111078B08	CAP CHIP RF 6.2 .25 NPO 100V
C5928	2113741N69	CAP CHIP CL2 X7R 10% 100000
C5965	2111078B19	CAP CHIP RF 16 5 NPO 100V
C5997	2113742B17	CAP CER 3.9 PF +/- .25PF
C5998	2113740B47	CAP CHIP REEL CL1 +/-30 82
C5999	2113742B20	CAP CER 6.8 PF .25 PF
CR5875	4880222R01	DIODE REVERSE POLARITY SPECTRA
CR5900 & CR5902	4880121R01	PWR PIN DIODE SMD TAPE & REEL
CR5904 & CR5905	4880142L01	DIODE PIN SOT 23 MMBV 3401
CR5906	4813825A05	DIODE 30V HOT CARRIER MMBD301L
E5800 & E5802	4280088P01	CLIP COAX
E5803	2680187N02	HEATSINK, TO39
E5804	8480110P05	BD CKT PA UHF
E5804	2680201R02	HEATSINK DIODE TIN PLATED
E5806 thru E5808	4280088P01	CLIP COAX
E5808	4280202R02	CLIP COAX TIN PLATED
J0001	2880102M11	PLUG VERTICAL 12 POS
L5801	2480067M01	CHK RF CHIP BEAD INDUCTOR 28MZ
L5802	2480091G21	COIL AIRWOUND
L5805	2480091G23	COIL AIRWOUND
L5806	2480067M01	CHK RF CHIP BEAD INDUCTOR 28MZ
L5820 & L5821	2480091G21	COIL AIRWOUND
L5850	2480091G21	COIL AIRWOUND
L5851	2480090G16	COIL AIRWOUND RF 000.000
L5853	2480090G03	COIL AIRWOUND
L5855	2480091G21	COIL AIRWOUND
L5858 & L5875	2480090G03	COIL AIRWOUND
L5876 & L5877	2480091G20	COIL AIRWOUND
L5880 & L5881	2480091G36	COIL AIRWOUND
L5882	2480090G19	COIL AIRWOUND
L5882	2480090G10	COIL AIRWOUND
L5900	2480090G13	COIL AIRWOUND
L5901	2480090G16	COIL AIRWOUND RF 000.000
L5902	2480090G19	COIL AIRWOUND
L5903	2480090G03	COIL AIRWOUND
L5904	2480140E11	INDUCTOR CHIP 360 NH

ITEM	MOTOROLA PART NUMBER	DESCRIPTION
L5905 thru L5910	2480067M01	CHK RF CHIP BEAD INDUCTOR 28MZ
L5927	2480091G24	COIL AIRWOUND
MP0002	2680139P02	SHLD HAR FLTR TIN PLATED
Q5800	4880141L01	TSTR PNP SOT23 LO PROFILE TAPE
Q5801	4880182D50	TSTR SI SORF 4V 750MW 960MHZ
Q5802	4880141L01	TSTR PNP SOT23 LO PROFILE TAPE
Q5803	4880225C09	TSTR M25C09
Q5804	4880141L01	TSTR PNP SOT23 LO PROFILE TAPE
Q5805 & Q5806	4880141L02	TSTR NPN SOT23 LO PROFILE TAPE
Q5850	4880225C27	TSTR RF MRF654F IN CS12 PKG
Q5851	4880225C30	TSTR RF 14W/50W UHF .5 CQ
Q5875	4880225C29	TSTR RF MRF658 IN FLANGE PKG
Q5876	4880225C29	TSTR RF MRF658 IN FLANGE PKG
R5801	0611077A30	RES CHIP 15 5 1/8W
R5802	0611077A74	RES CHIP 1000 5 1/8
R5803	0611077A82	RES CHIP 2200 5 1/8
R5805	0611077A26	RES CHIP 10 5 1/8W
R5806	0611077A50	RES CHIP 100 5 1/8W
R5807	0611077A82	RES CHIP 2200 5 1/8
R5808	0611077A90	RES CHIP 4700 5 1/8
R5809	0611077A78	RES CHIP 1500 5 1/8
R5810	0611077A26	RES CHIP 10 5 1/8W
R5811	0611077A74	RES CHIP 1000 5 1/8
R5812	0611077A01	RES CHIP JUMPER
R5816	0611077A80	RES CHIP 1800 5 1/8
R5817	0611077A74	RES CHIP 1000 5 1/8
R5818	0611077A62	RES CHIP 330 5 1/8W
R5819	0611077A86	RES CHIP 3300 5 1/8
R5820	0611077B01	RES CHIP 12K 5 1/8W
R5821	0611077A90	RES CHIP 4700 5 1/8
R5822	0611077A74	RES CHIP 1000 5 1/8
R5823	0611077A98	RES CHIP 10K 5 1/8W
R5824	0611077A90	RES CHIP 4700 5 1/8
R5825	0611077B05	RES CHIP 18K 5 1/8W
R5826	0611077A68	RES CHIP 560 5 1/8W
R5827	0611077A50	RES CHIP 100 5 1/8W
R5828	0611077B15	RES CHIP 47K 5 1/8W
R5843	0611077B07	RES CHIP 22K 5 1/8W
R5850 & R5851	0611077A10	RES CHIP 2.2 5 1/8W
R5853 & R5854	0611077A10	RES CHIP 2.2 5 1/8W

ITEM	MOTOROLA PART NUMBER	DESCRIPTION
R5855	0611077A50	RES CHIP 100 5 1/8W
R5857	0611077A82	RES CHIP 2200 5 1/8
R5858	0611077A74	RES CHIP 1000 5 1/8
R5859	0611077A50	RES CHIP 100 5 1/8W
R5875	1780165C02	RES SHUNT
R5876 & R5877	0611077A10	RES CHIP 2.2 5 1/8W
R5878	0680194M01	RES 10 OHMS 5% 1W
R5879 & R5880	0680194M13	RES 33 OHMS 5% 1W
R5881	0680194M01	RES 10 OHMS 5% 1W
R5882	0680194M01	RES 10 OHMS 5% 1W
R5900	0680194M18	RES 51 OHMS 5% 1W
R5901	0680194M01	RES 10 OHMS 5% 1W
R5904	0611077A52	RES CHIP 120 5 1/8W
R5905	0611077A60	RES CHIP 270 5 1/8W
R5906	0611077A74	RES CHIP 1000 5 1/8
R5907	0611077B11	RES CHIP 33K 5 1/8W
R5908 & R5909	0611077A54	RES CHIP 150 5 1/8W
R5910	0611077B23	RES CHIP 100K 5 1/8W
R5911	0611077A01	RES CHIP JUMPER
R5912 & R5913	0611077B47	RES CHIP 1 MEG 5 1/8W
R5915	0611077A26	RES CHIP 10 5 1/8W
R5916	0611077A74	RES CHIP 1000 5 1/8
R5917	0680194M01	RES 10 OHMS 5% 1W
RT5875 & RT5904	0680149M02	THERMISTOR CHIP 100K OHM

HLE6051 UHF R1 100-Watt PA Parts List

ITEM	MOTOROLA PART NUMBER	DESCRIPTION
C5801	2113741N69	CAP CHIP CL2 X7R 10% 100000
C5802 & C5803	-----	NOTPLACED
C5804	2113741N45	CAP CHIP CL2 X7R 10% 10000
C5805	2113740B30	CAP CHIP REEL CL1 +/-30 16
C5806	2113740B34	CAP CHIP REEL CL1 +/-30 24
C5807	2113740B49	CAP CHIP REEL CL1 +/-30 100
C5808	2113741N45	CAP CHIP CL2 X7R 10% 10000
C5810	2113741N69	CAP CHIP CL2 X7R 10% 100000
C5811	2113740B49	CAP CHIP REEL CL1 +/-30 100
C5813	2113741N45	CAP CHIP CL2 X7R 10% 10000
C5815 thru C5818	2113740B49	CAP CHIP REEL CL1 +/-30 100
C5820	2113740B25	CAP CHIP REEL CL1 +/-30 10
C5821	2113740B29	CAP CHIP REEL CL1 +/-30 15
C5822	2113740B09	CAP CHIP REEL CL1 +/-30 2.2

ITEM	MOTOROLA PART NUMBER	DESCRIPTION
C5823	2113740B24	CAP CHIP REEL CL1 +/-30 9.1
C5824	2113740B28	CAP CHIP REEL CL1 +/-30 13
C5826	2113741N45	CAP CHIP CL2 X7R 10% 10000
C5830 & C5831	2380090M32	CAP ALU 220 20 35V
C5838	2113741N21	CAP CHIP CL2 X7R 10% 1000
C5839	-----	NOTPLACED
C5840 thru C5844	2113741N21	CAP CHIP CL2 X7R 10% 1000
C5846, C5848 & C5849	2113741N21	CAP CHIP CL2 X7R 10% 1000
C5851	2113740B36	CAP CHIP REEL CL1 +/-30 30
C5852	2113740B36	CAP CHIP REEL CL1 +/-30 30
C5853	-----	NOTPLACED
C5854	2111078B42	CAP CHIP RF 100 5 NPO 100V
C5855	2111078B29	CAP CHIP RF 33 5 NPO 100V
C5856	2113740B49	CAP CHIP REEL CL1 +/-30 100
C5856 & C5857	-----	NOTPLACED
C5858	2113740B21	CAP CHIP REEL CL1 +/-30 6.8
C5859	2113740B17	CAP CHIP REEL CL1 +/-30 4.7
C5860	2113740B49	CAP CHIP REEL CL1 +/-30 100
C5861 & C5862	2111078B31	CAP CHIP RF 36 5 NPO 100V
C5863 & C5864	2113742B28	CAP CER 33.0 PF 5% PF
C5865	2111078B07	CAP CHIP RF 5.6 .25 NPO 100V
C5866	-----	NOTPLACED
C5867	2111078B25	CAP CHIP RF 27 5 NPO 100V
C5868	2113740B49	CAP CHIP REEL CL1 +/-30 100
C5869	-----	NOTPLACED
C5870	2113741N69	CAP CHIP CL2 X7R 10% 100000
C5871	-----	NOTPLACED
C5872	2113740B49	CAP CHIP REEL CL1 +/-30 100
C5873	2113741N69	CAP CHIP CL2 X7R 10% 100000
C5874	2380090M24	CAP ALU 10 20 50V SURF MT
C5875	2111078B15	CAP CHIP RF 12 5 NPO 100V
C5876	2111078B27	CAP CHIP RF 30 5 NPO 100V
C5877	2111078B15	CAP CHIP RF 12 5 NPO 100V
C5878	2111078B19	CAP CHIP RF 16 5 NPO 100V
C5879 & C5880	2111078B27	CAP CHIP RF 30 5 NPO 100V
C5881 & C5882	2111078B07	CAP CHIP RF 5.6 .25 NPO 100V
C5883 & C5884	2113741N21	CAP CHIP CL2 X7R 10% 1000
C5885 thru C5888	2184366F44	CAP MICA 40 5 250V

ITEM	MOTOROLA PART NUMBER	DESCRIPTION
C5889 & C5890	2113741N69	CAP CHIP CL2 X7R 10% 100000
C5891 thru C5894	2184366F44	CAP MICA 40 5 250V
C5895 & C5896	-----	NOTPLACED
C5897	2113741N69	CAP CHIP CL2 X7R 10% 100000
C5898	2113742B21	CAP CER 8.2 PF .50 PF
C5899	-----	NOTPLACED
C5900	2111078B19	CAP CHIP RF 16 5 NPO 100V
C5901	2111078B42	CAP CHIP RF 100 5 NPO 100V
C5904	2113740B21	CAP CHIP REEL CL1 +/-30 6.8
C5905	2113740B49	CAP CHIP REEL CL1 +/-30 100
C5906	2113740B23	CAP CHIP REEL CL1 +/-30 8.2
C5908 & C5909	2113740B49	CAP CHIP REEL CL1 +/-30 100
C5910	2113740B01	CAP CHIP REEL CL1 +/-30 1.0
C5912	2111078B42	CAP CHIP RF 100 5 NPO 100V
C5915	2113740B49	CAP CHIP REEL CL1 +/-30 100
C5917	2111078B01	CAP CHIP RF 3.3 .25 NPO 100V
C5918	2113740B09	CAP CHIP REEL CL1 +/-30 2.2
C5919	2113740B49	CAP CHIP REEL CL1 +/-30 100
C5920	-----	NOTPLACED
C5921	2113740B49	CAP CHIP REEL CL1 +/-30 100
C5922	-----	NOTPLACED
C5923	2113741N45	CAP CHIP CL2 X7R 10% 10000
C5924	2113740B49	CAP CHIP REEL CL1 +/-30 100
C5925	-----	NOTPLACED
C5926	2111078B13	CAP CHIP RF 10 .5 NPO 100V
C5927	2113742B31	CAP CER 6.2PF +/- .25PF
C5928	2113741N69	CAP CHIP CL2 X7R 10% 100000
C5965	2111078B22	CAP CHIP RF 22 5 NPO 100V
C5997	2113742B23	CAP CHIP 12PF
C5998 thru C6003	-----	NOTPLACED
C6004	2111078B03	CAP CHIP RF 3.9 .25 NPO 100V
C6005	0780255R01	BRKT FLTR
CR5875	4880222R01	DIODE REVERSE POLARITY SPECTRA
CR5900 & CR5902	4880121R01	PWR PIN DIODE SMD TAPE & REEL
CR5904 & CR5905	4880142L01	DIODE PIN SOT 23 MMBV 3401
CR5906	4813825A05	DIODE 30V HOT CARRIER MMBD301L
E5800	4280088P01	CLIP COAX
E5801	2680201R02	HEATSINK DIODE TIN PLATED
E5802	4280088P01	CLIP COAX

ITEM	MOTOROLA PART NUMBER	DESCRIPTION
E5803	2680187N02	HEATSINK, TO39
E5806 & E5807	4280088P01	CLIP COAX
E5808	4280202R02	CLIP COAX TIN PLATED
J1103	2880102M11	PLUG VERTICAL 12 POS
J5901	4280088P01	CLIP COAX
L5801	2480067M01	CHK RF CHIP BEAD INDUCTOR 28MZ
L5802	2480091G21	COIL AIRWOUND
L5805	2480091G23	COIL AIRWOUND
L5806	2480067M01	CHK RF CHIP BEAD INDUCTOR 28MZ
L5810 & L5811	2484657R01	INDUCTOR BEAD CHIP
L5820 & L5821	2480091G21	COIL AIRWOUND
L5850	2480091G21	COIL AIRWOUND
L5851	2480091G23	COIL AIRWOUND
L5852	2484657R01	INDUCTOR BEAD CHIP
L5853	2480090G03	COIL AIRWOUND
L5854	2484657R01	INDUCTOR BEAD CHIP
L5855	2480091G21	COIL AIRWOUND
L5857	2484657R01	INDUCTOR BEAD CHIP
L5858	2480090G03	COIL AIRWOUND
L5859	2484657R01	INDUCTOR BEAD CHIP
L5875	2480090G03	COIL AIRWOUND
L5876 & L5877	2480091G21	COIL AIRWOUND
L5878 & L5879	2484657R01	INDUCTOR BEAD CHIP
L5880 & L5881	2480091G36	COIL AIRWOUND
L5882	2480090G16	COIL AIRWOUND RF 000.000
L5884	2484657R01	INDUCTOR BEAD CHIP
L5900	2480090G13	COIL AIRWOUND
L5901	2480090G16	COIL AIRWOUND RF 000.000
L5902	2480090G19	COIL AIRWOUND
L5903	2480090G03	COIL AIRWOUND
L5904	2480140E11	INDUCTOR CHIP 360 NH
L5905 thru L5910	2480067M01	CHK RF CHIP BEAD INDUCTOR 28MZ
L5927	2480091G24	COIL AIRWOUND
MP0002	2680139P02	SHLD HAR FLTR TIN PLATED
Q5800	4880141L01	TSTR PNP SOT23 LO PROFILE TAPE
Q5801	4880182D50	TSTR SI SORF 4V 750MW 960MHZ
Q5802	4880141L01	TSTR PNP SOT23 LO PROFILE TAPE
Q5803	4880225C09	TSTR M25C09

ITEM	MOTOROLA PART NUMBER	DESCRIPTION
Q5804	4880141L01	TSTR PNP SOT23 LO PROFILE TAPE
Q5805 & Q5806	4880141L02	TSTR NPN SOT23 LO PROFILE TAPE
Q5850	4880225C27	TSTR RF MRF654F IN CS12 PKG
Q5851	4880225C30	TSTR RF 14W/50W UHF .5 CQ
Q5875	4880225C29	TSTR RF MRF658 IN FLANGE PKG
Q5876	4880225C29	TSTR RF MRF658 IN FLANGE PKG
R5801	0611077A30	RES CHIP 15 5 1/8W
R5802	0611077A74	RES CHIP 1000 5 1/8
R5803	0611077A82	RES CHIP 2200 5 1/8
R5805	0611077A26	RES CHIP 10 5 1/8W
R5806	0611077A50	RES CHIP 100 5 1/8W
R5807	0611077A82	RES CHIP 2200 5 1/8
R5808	0611077A90	RES CHIP 4700 5 1/8
R5809	0611077A78	RES CHIP 1500 5 1/8
R5810	0611077A26	RES CHIP 10 5 1/8W
R5811	0611077A74	RES CHIP 1000 5 1/8
R5812	0611077A01	RES CHIP JUMPER
R5813 & R5814	-----	NOTPLACED
R5816	0611077A80	RES CHIP 1800 5 1/8
R5817	0611077A74	RES CHIP 1000 5 1/8
R5818	0611077A62	RES CHIP 330 5 1/8W
R5819	0611077A86	RES CHIP 3300 5 1/8
R5820	0611077B01	RES CHIP 12K 5 1/8W
R5821	0611077A90	RES CHIP 4700 5 1/8
R5822	0611077A74	RES CHIP 1000 5 1/8
R5823	0611077A98	RES CHIP 10K 5 1/8W
R5824	0611077A90	RES CHIP 4700 5 1/8
R5825	0611077B05	RES CHIP 18K 5 1/8W
R5826	0611077A68	RES CHIP 560 5 1/8W
R5827	0611077A50	RES CHIP 100 5 1/8W
R5828	0611077B15	RES CHIP 47K 5 1/8W
R5843	0611077B07	RES CHIP 22K 5 1/8W
R5850 & R5851	0611077A10	RES CHIP 2.2 5 1/8W
R5853 & R5854	0611077A10	RES CHIP 2.2 5 1/8W
R5855	0611077A74	RES CHIP 1000 5 1/8
R5857	0611077A82	RES CHIP 2200 5 1/8
R5858	0611077A74	RES CHIP 1000 5 1/8
R5859	0611077A50	RES CHIP 100 5 1/8W
R5875	1780165C02	RES SHUNT
R5876 & R5877	0611077A10	RES CHIP 2.2 5 1/8W
R5878	0680194M01	RES 10 OHMS 5% 1W
R5879 & R5880	0680194M13	RES 33 OHMS 5% 1W

ITEM	MOTOROLA PART NUMBER	DESCRIPTION
R5881 & R5882	0680194M01	RES 10 OHMS 5% 1W
R5900	0680194M18	RES 51 OHMS 5% 1W
R5901	0680194M01	RES 10 OHMS 5% 1W
R5904	0611077A50	RES CHIP 100 5 1/8W
R5905	0611077A60	RES CHIP 270 5 1/8W
R5906	0611077A74	RES CHIP 1000 5 1/8
R5907	0611077B11	RES CHIP 33K 5 1/8W
R5908 & R5909	0611077A54	RES CHIP 150 5 1/8W
R5910	0611077B23	RES CHIP 100K 5 1/8W
R5911	0611077A74	RES CHIP 1000 5 1/8
R5912 & R5913	0611077B47	RES CHIP 1 MEG 5 1/8W
R5914	0611077A90	RES CHIP 4700 5 1/8
R5915	0611077A26	RES CHIP 10 5 1/8W
R5916	0611077A66	RES CHIP 470 5 1/8W
R5917	0680194M01	RES 10 OHMS 5% 1W
RT5875 & RT5904	0680149M02	THERMISTOR CHIP 100K OHM
Z1	4813830A14	DIODE 5.1V 5% 225MW MMBZ5231B_
Z2	-----	NOTPLACED
	2280128P01	PIN POLARIZING
	8480110P05	BD CKT PA UHF

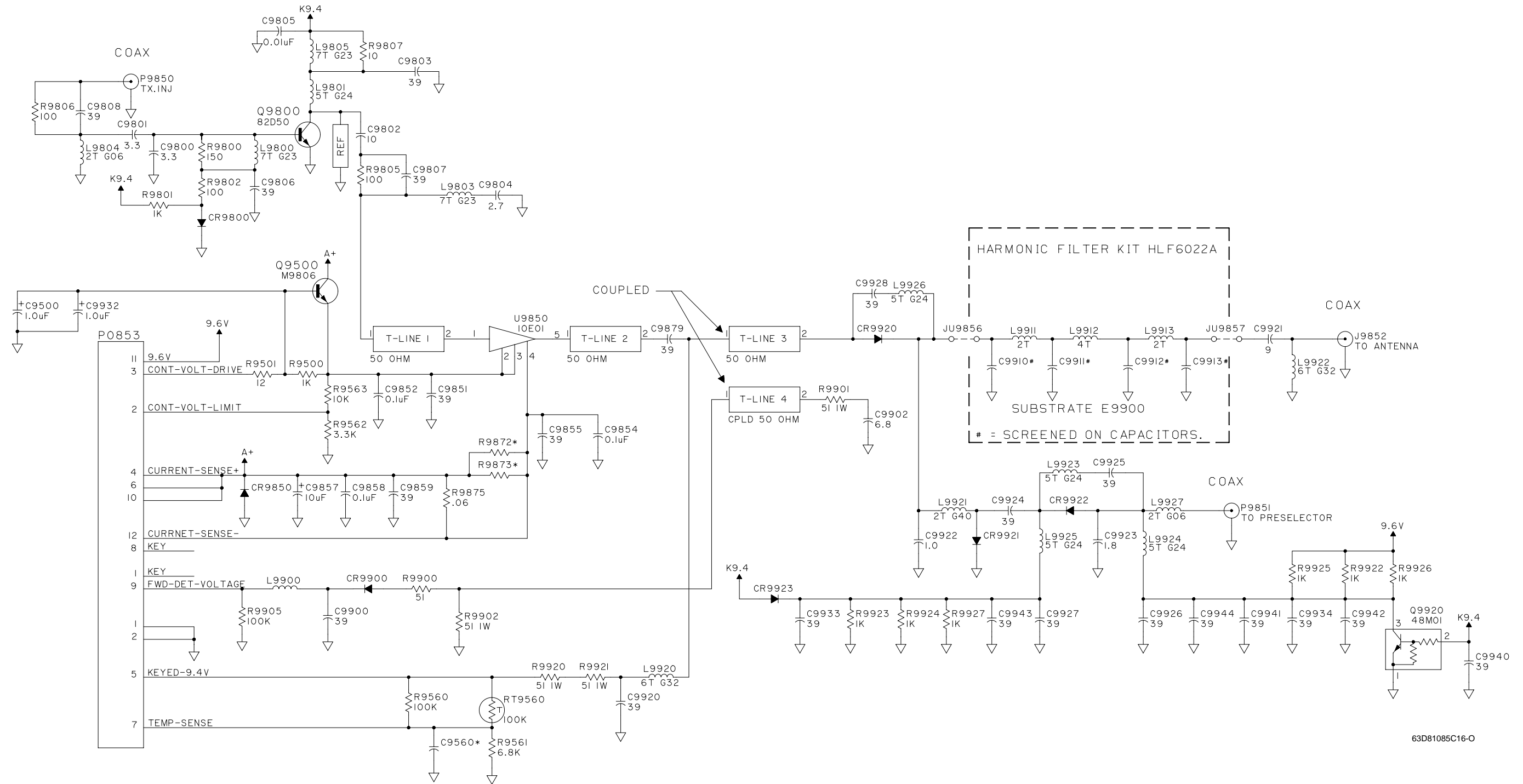

HLF6078B 800 MHz 15-Watt PA Schematic

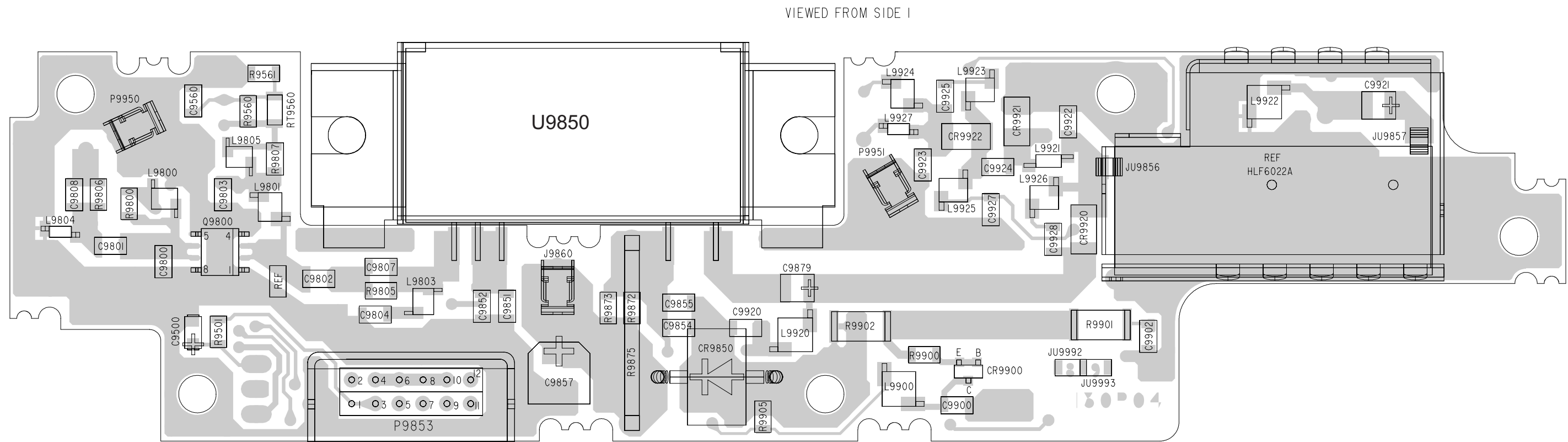

HLF6078B 800 MHz 15-Watt PA Component Location Diagram, Side 1

VIEWED FROM SIDE 2

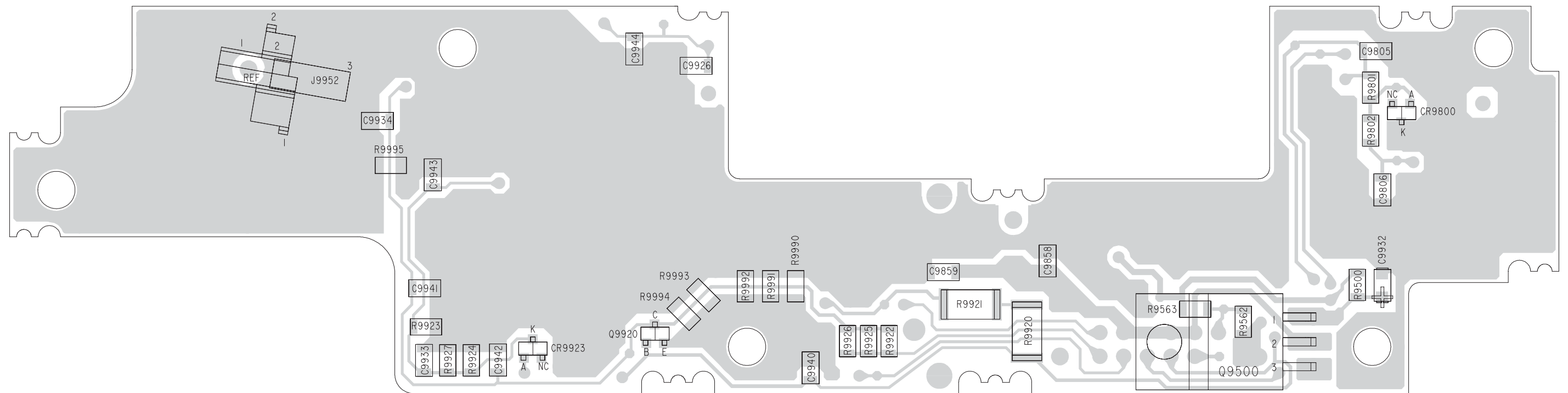

HLF6078B 800 MHz 15-Watt PA Component Location Diagram, Side 2

HLF6078C 800MHz 15-Watt PA Parts List

ITEM	MOTOROLA PARTS NUMBER	DESCRIPTION
C9500	2311049A37	CAP TANT CHIP 1 20 20
C9800 & C9801	2113740B13	CAP CHIP REEL CL1 +/-30 3.3
C9802	2113740B25	CAP CHIP REEL CL1 +/-30 10
C9803	2113740B39	CAP CHIP REEL CL1 +/-30 39
C9804	2113740B11	CAP CHIP REEL CL1 +/-30 2.7
C9805	2113741N45	CAP CHIP CL2 X7R 10% 10000
C9806 thru C9808	2113740B39	CAP CHIP REEL CL1 +/-30 39
C9851	2113740B39	CAP CHIP REEL CL1 +/-30 39
C9852	2113741N69	CAP CHIP CL2 X7R 10% 100000
C9854	2113741N69	CAP CHIP CL2 X7R 10% 100000
C9855	2113740B39	CAP CHIP REEL CL1 +/-30 39
C9857	2380090M24	CAP ALU 10 20 50V SURF MT
C9858	2111078B29	CAP CHIP RF 33 5 NPO 100V
C9859	2113741N69	CAP CHIP CL2 X7R 10% 100000
C9879	2111078B32	CAP CHIP RF 39 5 NPO 100V
C9900	2113740B39	CAP CHIP REEL CL1 +/-30 39
C9902	2113740B25	CAP CHIP REEL CL1 +/-30 10
C9920	2113740B39	CAP CHIP REEL CL1 +/-30 39
C9921	2111078B32	CAP CHIP RF 39 5 NPO 100V
C9922	2113740B01	CAP CHIP REEL CL1 +/-30 1.0
C9923	2113740B07	CAP CHIP REEL CL1 +/-30 1.8
C9924 thru C9928	2113740B39	CAP CHIP REEL CL1 +/-30 39
C9932	2311049A37	CAP TANT CHIP 1 20 20
C9933 & C9934	2113740B39	CAP CHIP REEL CL1 +/-30 39
C9940 thru C9944	2113740B39	CAP CHIP REEL CL1 +/-30 39
CR9800	4811058B11	DIODE 48S11058A11 A/P
CR9850	4880236E07	DIODE TRANSIENT SUP
CR9900	4813825A05	DIODE 30V HOT CARRIER MMBD301L
CR9920 thru CR9922	4880236E24	DIODE PIN
CR9923	4811058B11	DIODE 48S11058A11 A/P
J9860	2980014A03	CLIP COAX TERMINAL
L9800	2480091G23	COIL AIRWOUND
L9801	2480091G24	COIL AIRWOUND
L9803	2480091G23	COIL AIRWOUND
L9804	2480091G06	COIL AIRWOUND
L9805	2480091G23	COIL AIRWOUND

ITEM	MOTOROLA PARTS NUMBER	DESCRIPTION
L9900 & L9920	2480091G32	COIL AIRWOUND
L9921	2480091G40	COIL AIRWOUND
L9922	2480091G32	COIL AIRWOUND
L9923	2480091G23	COIL AIRWOUND
L9924	2480091G01	COIL AIRWOUND
L9925 & L9926	2480091G24	COIL AIRWOUND
L9927	2480091G06	COIL AIRWOUND
P9853	6480262N01	PLATE LP FEEDTHRU ASSEMBLY
P9950 & P9951	2980014A03	CLIP COAX TERMINAL
Q9800	4880182D50	TSTR SI SORF 4V 750MW 960MHZ
Q9500	4813822D56	TSTR NPN 100V 6A
Q9920	4880048M01	TSTR NPN DIG 47K/47K
R9500	0611077A74	RES CHIP 1000 5 1/8
R9501	0611077A28	RES CHIP 12 5 1/8W
R9560	0611077B23	RES CHIP 100K 5 1/8W
R9561	0611077A94	RES CHIP 6800 5 1/8
R9562	0611077A86	RES CHIP 3300 5 1/8
R9563	0611077A98	RES CHIP 10K 5 1/8W
R9800	0611077A54	RES CHIP 150 5 1/8W
R9801	0611077A74	RES CHIP 1000 5 1/8
R9802 & R9805	0611077A50	RES CHIP 100 5 1/8W
R9806	0611077A50	RES CHIP 100 5 1/8W
R9807	0611077A26	RES CHIP 10 5 1/8W
R9875	1780228N03	RESISTOR SHUNT
R9900	0611077A43	RES CHIP 51 5 1/8W
R9901 & R9902	0680194M18	RES 51 OHMS 5% 1W
R9905	0611077B23	RES CHIP 100K 5 1/8W
R9920 & R9921	0680194M18	RES 51 OHMS 5% 1W
R9922 thru R9927	0611077A74	RES CHIP 1000 5 1/8
R9990 thru R9995	0611077A01	RES CHIP JUMPER
RT9560	0680149M02	THERMISTOR CHIP 100K OHM
U9850	5180110E01	MODE RF PWR 800MH 20W
	2280128P01	PIN POLARIZING
	8480130P05	BD CKT 1.5/15W PA

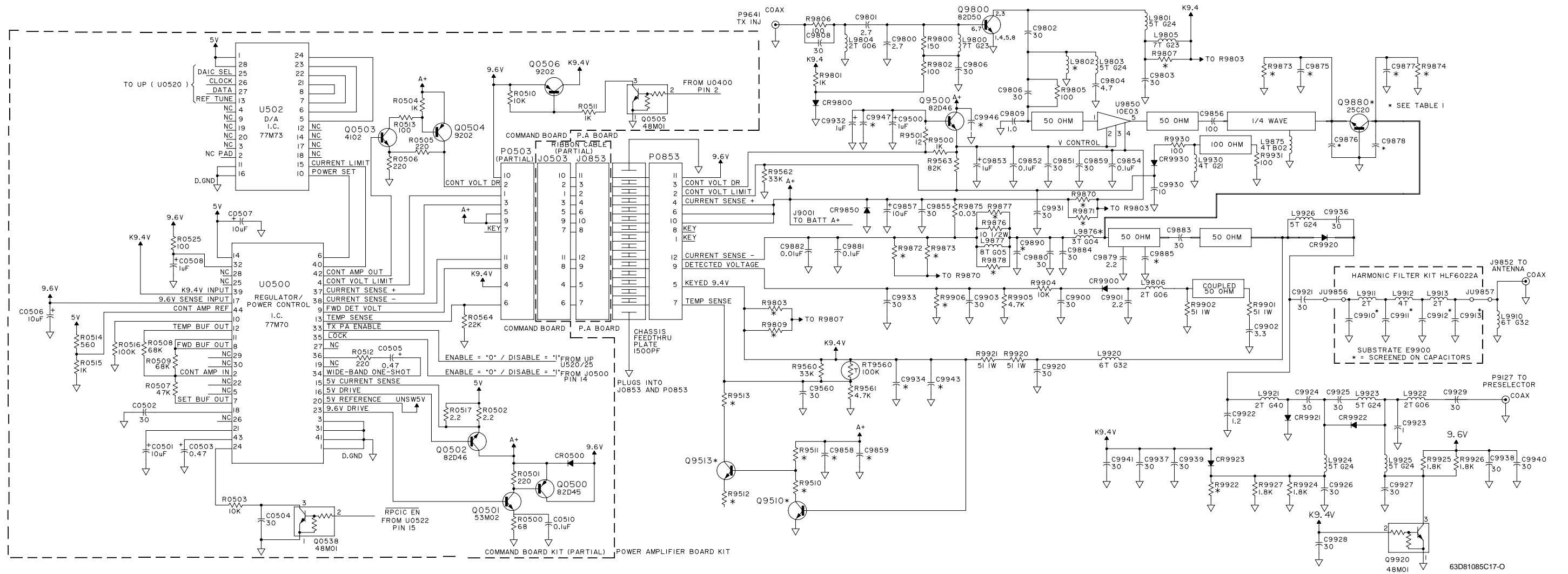

HLF6077D 800 MHz 35-Watt PA Schematic

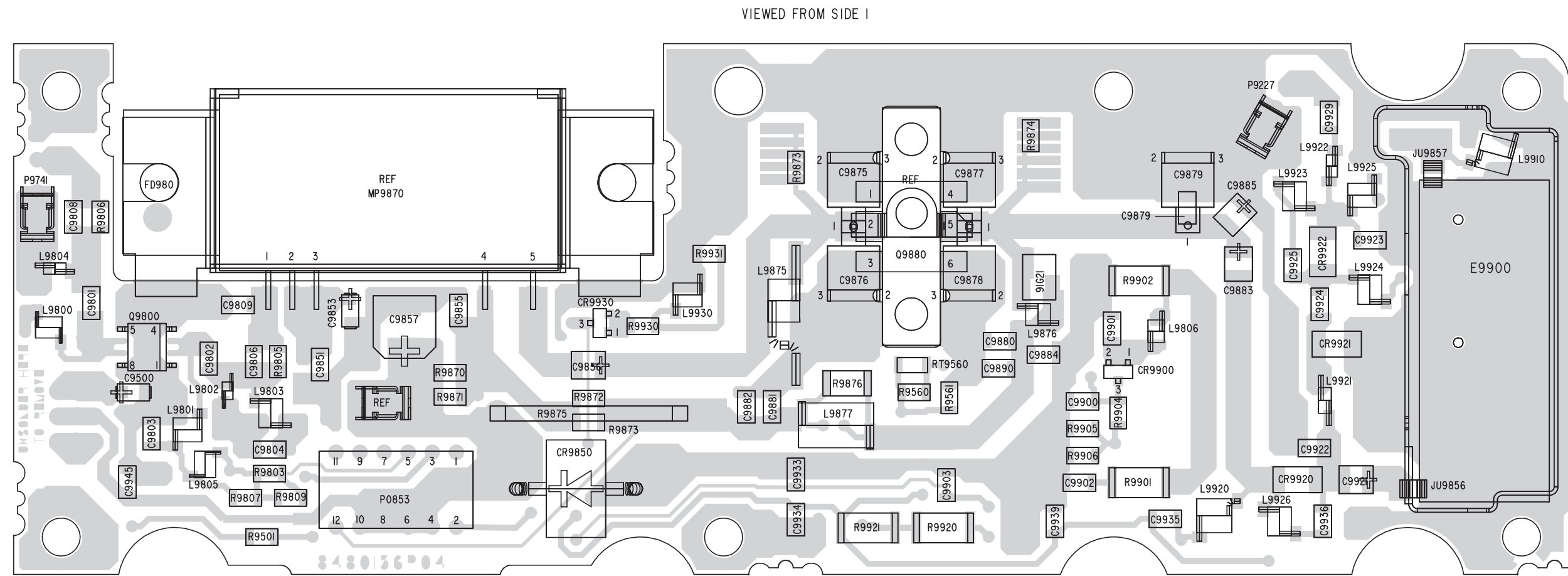

Spectra
8480156p04.A

HLF6077D 800 MHz 35-Watt PA Component Location Diagram, Side 1

HLF6077D 800MHz 35-Watt PA Parts List

ITEM	MOTOROLA PART NUMBER	DESCRIPTION
C9500	2311049A37	CAP TANT CHIP 1 20 20
C9560	2113740B39	CAP CHIP REEL CL1 +/-30 39
C9800 & C9801	2113740B13	CAP CHIP REEL CL1 +/-30 3.3
C9802	2113740B15	CAP CHIP REEL CL1 +/-30 3.9
C9803	2113740B39	CAP CHIP REEL CL1 +/-30 39
C9804	2113740B21	CAP CHIP REEL CL1 +/-30 6.8
C9806 thru C9808	2113740B39	CAP CHIP REEL CL1 +/-30 39
C9809	-----	NOTPLACED
C9851	2113740B39	CAP CHIP REEL CL1 +/-30 39
C9852	2113741N69	CAP CHIP CL2 X7R 10% 100000
C9853	2311049A37	CAP TANT CHIP 1 20 20
C9854	2113741N69	CAP CHIP CL2 X7R 10% 100000
C9855	2113740B39	CAP CHIP REEL CL1 +/-30 39
C9856	2111078B42	CAP CHIP RF 100 5 NPO 100V
C9857	2380090M24	CAP ALU 10 20 50V SURF MT
C9858	2111078B29	CAP CHIP RF 33 5 NPO 100V
C9859	-----	NOTPLACED
C9879	2180240G69	CAP MTL CLAD MICA PF
C9880	2113740B39	CAP CHIP REEL CL1 +/-30 39
C9881	2113741N69	CAP CHIP CL2 X7R 10% 100000
C9882	2113741N45	CAP CHIP CL2 X7R 10% 10000
C9883	2111078B32	CAP CHIP RF 39 5 NPO 100V
C9884	2113740B39	CAP CHIP REEL CL1 +/-30 39
C9885 & C9890	-----	NOTPLACED
C9900	2113740B39	CAP CHIP REEL CL1 +/-30 39
C9901	2113740B13	CAP CHIP REEL CL1 +/-30 3.3
C9902	2113740B25	CAP CHIP REEL CL1 +/-30 10
C9903 & C9920	2113740B39	CAP CHIP REEL CL1 +/-30 39
C9921	2111078B32	CAP CHIP RF 39 5 NPO 100V
C9922	2113740B01	CAP CHIP REEL CL1 +/-30 1.0
C9923	2113740B05	CAP CHIP REEL CL1 +/-30 1.5
C9924 thru C9929	2113740B39	CAP CHIP REEL CL1 +/-30 39
C9930	2113740B25	CAP CHIP REEL CL1 +/-30 10
C9931	2113740B39	CAP CHIP REEL CL1 +/-30 39
C9932	2311049A37	CAP TANT CHIP 1 20 20
C9933 thru C9941	2113740B39	CAP CHIP REEL CL1 +/-30 39
C9942 & C9943	-----	NOTPLACED
C9945	2113740B39	CAP CHIP REEL CL1 +/-30 39
C9946	-----	NOTPLACED
C9947	2113740B39	CAP CHIP REEL CL1 +/-30 39

ITEM	MOTOROLA PART NUMBER	DESCRIPTION
CR9800	4880066M01	DIODE SIGNAL RLS4148
CR9850	4880236E07	DIODE TRANSIENT SUP
CR9900	4813825A05	DIODE 30V HOT CARRIER MMBD301L
CR9920 thru CR9922	4880236E24	DIODE PIN
CR9923	4880066M01	DIODE SIGNAL RLS4148
CR9930	4813825A05	DIODE 30V HOT CARRIER MMBD301L
J9001	2980014A03	CLIP COAX TERMINAL
L9800	2480091G23	COIL AIRWOUND
L9801	2480091G24	COIL AIRWOUND
L9802	2480091G13	COIL AIRWOUND
L9803	2480091G24	COIL AIRWOUND
L9804	2480091G06	COIL AIRWOUND
L9805	2480091G23	COIL AIRWOUND
L9806	2480091G06	COIL AIRWOUND
L9876	2480091G21	COIL AIRWOUND
L9877	2480090G05	COIL AIRWOUND
L9910 & L9920	2480091G32	COIL AIRWOUND
L9921	2480091G40	COIL AIRWOUND
L9922	2480091G06	COIL AIRWOUND
L9923 thru L9926	2480091G24	COIL AIRWOUND
L9930	2480091G21	COIL AIRWOUND
MP0001	2680090N02	SHLD MID PWR FENCE TIN PLATED
P0853	0980103M04	RECEPTICAL RIGHT ANGLE 12 POS
P9227 & P9741	2980014A03	CLIP COAX TERMINAL
Q9500	4813822D56	TSTR NPN 100V 6A
Q9510	4880048M01	TSTR NPN DIG 47K/47K
Q9515	4880141L01	TSTR PNP SOT23 LO PROFILE TAPE
Q9800	4880182D50	TSTR SI SORF 4V 750MW 960MHZ
Q9920	4880048M01	TSTR NPN DIG 47K/47K
R9500	0611077A74	RES CHIP 1000 5 1/8
R9501	0611077A28	RES CHIP 12 5 1/8W
R9510	0611077B11	RES CHIP 33K 5 1/8W
R9511	0611077A98	RES CHIP 10K 5 1/8W
R9512	0611077A01	RES CHIP JUMPER
R9513	0611077B07	RES CHIP 22K 5 1/8W
R9560	-----	NOTPLACED
R9561	0611077A90	RES CHIP 4700 5 1/8
R9562	0611077B11	RES CHIP 33K 5 1/8W
R9563	0611077B21	RES CHIP 82K 5 1/8W
R9800	0611077A54	RES CHIP 150 5 1/8W

ITEM	MOTOROLA PART NUMBER	DESCRIPTION
R9801	0611077A74	RES CHIP 1000 5 1/8
R9802	0611077A50	RES CHIP 100 5 1/8W
R9803	-----	NOTPLACED
R9805 & R9806	0611077A50	RES CHIP 100 5 1/8W
R9807 & R9809	-----	NOTPLACED
R9870 & R9871	0611077A01	RES CHIP JUMPER
R9872 & R9873	-----	NOTPLACED
R9874	0611077A01	RES CHIP JUMPER
R9875	1780228N01	RESISTOR SHUNT
R9876	-----	NOTPLACED
R9877 & R9878	0611077A26	RES CHIP 10 5 1/8W
R9901 & R9902	0680194M18	RES 51 OHMS 5% 1W
R9904	0611077B07	RES CHIP 22K 5 1/8W
R9905	0611077B11	RES CHIP 33K 5 1/8W
R9906	-----	NOTPLACED
R9920 & R9921	0680194M18	RES 51 OHMS 5% 1W
R9922 thru R9927	0611077A74	RES CHIP 1000 5 1/8
R9928 & R9929	0611077A01	RES CHIP JUMPER
R9930	0611077A52	RES CHIP 120 5 1/8W
R9931	0611077A50	RES CHIP 100 5 1/8W
RT9560	0680149M02	THERMISTOR CHIP 100K OHM
U9850	5180110E01	MODE RF PWR 800MH 20W
	2280128P01	PIN POLARIZING
	8480156P04	BD CKT PA

Appendix A Secure Modules

A.1 Introduction

The secure modules are designed to digitally encrypt and decrypt voice and ASTRO data in ASTRO Digital Spectra and Digital Spectra Plus mobile radios. This section covers the following secure modules:

Table A-1. ASTRO Digital Spectra Secure Modules

KIT NO.	ENCRYPTION TYPE
HLN1441	DES, DES-XL, DES-OFB
NTN1158	DVI-XL
NTN1147	DVP-XL
NTN1369	DES-XL , DVP-XL
NTN1565	DES-OFB, DVP-XL

Table A-2. ASTRO Digital Spectra Plus Secure Modules

KIT NO.	ENCRYPTION TYPE
NNTN4024A	DES, DES-XL, DES-OFB
NNTN4025A	DVI-XL
NNTN4026A	DVP-XL
NNTN4027A	DES, DES-XL , DES-OFB with DVP-XL Encryption Kit

NOTE: The secure module is NOT serviceable. The information contained in this section is only meant to help determine whether a problem is due to the secure module or the radio itself.

The secure module uses a custom encryption integrated circuit (IC) and an encryption key variable to perform its encode/decode function. The encryption key variable is loaded into the secure module, via the radio's microphone connector, from a hand-held key-variable loader (KVL). The encryption IC corresponds to the particular encryption algorithm purchased. The encryption algorithms and their corresponding kit numbers are listed in the above table.

NOTE: When ordering replacement modules, make sure that the kit and board numbers of the module that is ordered are the same as those of the module that is being replaced.

A.2 Circuit Description

The secure module operates from three power supplies (UNSW_B+, SW_B+, and KG_BACKUP). The SW_B+ is turned on and off by the radio's on/off switch. The UNSW_B+ provides power to the secure module as long as the radio battery is in place.

Key variables are loaded into the secure module through connector P1, pin 15. Up to 16 keys (depending on the type of encryption module) can be stored in the module at a time. The key can be infinite key retention or 3 day key retention, depending on how the code plug is setup.

The radio's host processor communicates with the secure module on the Serial Peripheral Interface (SPI) bus. The host processor is the master on this bus, while the secure module is a slave on the bus. The SPI bus consists of five signal lines. Refer to [Table A-1](#) for signal information. A communications failure between the host processor and the secure module will be indicated as an "ERROR 09/10" message on the radio display.

A.3 Troubleshooting Secure Operations

Refer to the *ASTRO Digital Spectra and Digital Spectra Plus Mobile Radios Basic Service Manual* (6881076C20) for disassembly and reassembly information. A key-variable loader (KVL) and oscilloscope are needed to troubleshoot the secure module.

NOTE: The secure module itself is not serviceable. If the secure module is found to be defective, it must be replaced.

A.3.1 Error 09/10, Error 09/90

The ASTRO Digital Spectra Mobile Radio automatically performs a self test on every power-up. Should the radio fail the self tests, the display will show "ERROR 09/10" or "ERROR 09/90" accompanied by a short beep. If the display shows "ERROR 09/10" or "ERROR 09/90," the radio failed the secure power-up tests and the host microcontroller was unable to communicate with the secure module via the SPI bus. Turn the radio off and back on. If the radio still does not pass the self tests, then a problem exists with the secure operations of the radio.

Troubleshooting information for "ERROR 09/10" is found in Troubleshooting [Chart C.17, "09/10, Secure Hardware Failure,"](#) on page 5-13. For "ERROR 09/90," see Troubleshooting [Chart C.18, "09/90, Secure Hardware Failure,"](#) on page 5-13.

A.3.2 Keyload

When the keyloading cable is attached to the ASTRO Digital Spectra Mobile Radio and "KEYLOADING" is not displayed on the ASTRO Digital Spectra Mobile Radio display, then the radio has not gone into KEYLOAD mode. For troubleshooting a "KEYLOAD" failure, refer to Troubleshooting [Chart C.21, "Key Load Fail,"](#) on page 5-16.

NOTE: ASTRO Digital Spectra Mobile Radios need a keyloader that has the ability to keyload a ASTRO Digital Spectra Mobile Radio. The keyloader must be either a KVL-3000 or later model key-variable loader.

Appendix B Replacement Parts Ordering

B.1 Basic Ordering Information

When ordering replacement parts or equipment information, the complete identification number should be included. This applies to all components, kits, and chassis. If the component part number is not known, the order should include the number of the chassis or kit of which it is a part, and sufficient description of the desired component to identify it.

Crystal orders should specify the crystal type number, crystal and carrier frequency, and the model number in which the part is used.

B.2 Transceiver Board and VOCON Board Ordering Information

When ordering a replacement Transceiver Board or VOCON Board, refer to the applicable Model Chart in the front of this manual, read the Transceiver Board or VOCON Board note, and include the proper information with your order.

B.3 Motorola Online

Motorola Online users can access our online catalog at

<https://www.motorola.com/businessonline>

To register for online access, please call 800-814-0601 (for U.S. and Canada Service Centers only).

B.4 Mail Orders

Send written orders to the following addresses:

**Replacement Parts/
Test Equipment/Manuals/
Crystal Service Items**
(United States and Canada):

Motorola Inc.
Customer Care and Services
Division*
Attention: Order Processing
1307 E. Algonquin Road
Schaumburg, IL 60196
U.S.A.

Federal Government Orders:

Motorola Inc.
U.S. Federal Government
Markets Division
Attention: Order Processing
7230 Parkway Drive
Landover, MD 21076
U.S.A.

International Orders:

Motorola Inc.
Customer Care and Services
Division*
Attention: Order Processing
1307 E. Algonquin Road
Schaumburg, IL 60196
U.S.A.

B.5 Telephone Orders

Customer Care and Services Division*
(United States and Canada)
7:00 AM to 7:00 PM (Central Standard Time)
Monday through Friday (Chicago, U.S.A.)
1-800-422-4210
(International Orders)
1-847-538-8023

U.S. Federal Government Markets Division (USFGMD)
1-800-826-1913 Federal Government Parts - Credit Cards Only
8:30 AM to 5:00 PM (Eastern Standard Time)

B.6 Fax Orders

Customer Care and Services Division*
(United States and Canada)
1-800-622-6210
(International)
847-576-3023

USFGMD
(Federal Government Orders)
1-800-526-8641 (For Parts and Equipment Purchase Orders)

B.7 Parts Identification

Customer Care and Services Division*
(United States and Canada)
1-800-422-4210, menu 3

B.8 Product Customer Service

Customer Response Center
(Non-technical Issues)
1-800-247-2346
FAX:1-800-247-2347

* Customer Care and Services Division (CCSD) was formerly known as Accessories and Aftermarket Division (AAD).

Glossary

This glossary contains an alphabetical listing of terms and their definitions that are applicable to ASTRO portable and mobile subscriber radio products.

Term	Definition
A/D	<i>See analog-to-digital conversion.</i>
Abacus IC	A custom integrated circuit providing a digital receiver intermediate frequency (IF) backend.
ADC	<i>See analog-to-digital converter.</i>
ADDAG	<i>See Analog-to-Digital, Digital-to-Analog and Glue.</i>
ALC	<i>See automatic level control.</i>
analog	Refers to a continuously variable signal or a circuit or device designed to handle such signals. <i>See also digital.</i>
Analog-to-Digital, Digital-to-Analog and Glue	An integrated circuit designed to be an interface between the radio's DSP, which is digital, and the analog transmitter and receiver ICs.
analog-to-digital conversion	Conversion of an instantaneous dc voltage level to a corresponding digital value. <i>See also D/A.</i>
analog-to-digital converter	A device that converts analog signals into digital data. <i>See also DAC.</i>
automatic level control	A circuit in the transmit RF path that controls RF power amplifier output, provides leveling over frequency and voltage, and protects against high VSWR.
band	Frequencies allowed for a specific purpose.
BBP	<i>See baseband interface port.</i>
baseband interface port	Synchronous serial interface to the transceiver board used to transfer transmit and receive audio data.
BGA	<i>See ball grid array.</i>
ball grid array	A type of IC package characterized by solder balls arranged in a grid that are located on the underside of the package.
CODEC	<i>See coder/decoder.</i>
coder/decoder	A device that encodes or decodes a signal.

Term	Definition
CPS	<i>See Customer Programming Software.</i>
Customer Programming Software	Software with a graphical user interface containing the feature set of an ASTRO radio. <i>See also RSS.</i>
D/A	<i>See digital-to-analog conversion.</i>
DAC	<i>See digital-to-analog converter.</i>
default	A pre-defined set of parameters.
digital	Refers to data that is stored or transmitted as a sequence of discrete symbols from a finite set; most commonly this means binary data represented using electronic or electromagnetic signals. <i>See also analog.</i>
digital-to-analog conversion	Conversion of a digital signal to a voltage that is proportional to the input value. <i>See also A/D.</i>
digital-to-analog converter	A device that converts digital data into analog signals. <i>See also ADC.</i>
Digital Private Line	A type of digital communications that utilizes privacy call, as well as memory channel and busy channel lock out to enhance communication efficiency.
digital signal processor	A microcontroller specifically designed for performing the mathematics involved in manipulating analog information, such as sound, that has been converted into a digital form. DSP also implies the use of a data compression technique.
digital signal processor code	Object code executed by the Digital Signal Processor in an ASTRO subscriber radio. The DSP is responsible for computation-intensive tasks, such as decoding ASTRO signaling.
DPL	<i>See Digital Private Line. See also PL.</i>
DSP	<i>See digital signal processor.</i>
DSP code	<i>See digital signal processor code.</i>
DTMF	<i>See dual tone multi-frequency.</i>
dual tone multi-frequency	The system used by touch-tone telephones. DTMF assigns a specific frequency, or tone, to each key so that it can easily be identified by a microprocessor.
EEPOT	Electrically Programmable Digital Potentiometer.
EEPROM	<i>See Electrically Erasable Programmable Read-Only Memory.</i>

Term	Definition
Electrically Erasable Programmable Read-Only Memory	A special type of PROM that can be erased by exposing it to an electrical charge. An EEPROM retains its contents even when the power is turned off.
FCC	Federal Communications Commission.
firmware	Code executed by an embedded processor such as the Host or DSP in a subscriber radio. This type of code is typically resident in non-volatile memory and as such is more difficult to change than code executed from RAM.
FGU	<i>See frequency generation unit.</i>
flash	A non-volatile memory device similar to an EEPROM. Flash memory can be erased and reprogrammed in blocks instead of one byte at a time.
FLASHcode	A 13-digit code which uniquely identifies the System Software Package and Software Revenue Options that are enabled in a particular subscriber radio. FLASHcodes are only applicable for radios which are upgradeable through the FLASHport process.
FLASHport®	A Motorola term that describes the ability of a radio to change memory. Every FLASHport radio contains a FLASHport EEPROM memory chip that can be software written and rewritten to, again and again.
FMR	<i>See Florida Manual Revision.</i>
Florida Manual Revision	A publication that provides supplemental information for its parent publication before it is revised and reissued.
frequency	Number of times a complete electromagnetic-wave cycle occurs in a fixed unit of time (usually one second).
frequency generation unit	This unit generates ultra-stable, low-phase noise master clock and other derived synchronization clocks that are distributed throughout the communication network.
General-Purpose Input/Output	Pins whose function is programmable.
GPIO	<i>See General-Purpose Input/Output.</i>
host code	Object code executed by the host processor in an ASTRO subscriber radio. The host is responsible for control-oriented tasks such as decoding and responding to user inputs.
IC	<i>See integrated circuit.</i>
IF	Intermediate Frequency.
IMBE	A sub-band, voice-encoding algorithm used in ASTRO digital voice.

Term	Definition
inbound signaling word	Data transmitted on the control channel from a subscriber unit to the central control unit.
integrated circuit	An assembly of interconnected components on a small semiconductor chip, usually made of silicon. One chip can contain millions of microscopic components and perform many functions.
ISW	<i>See inbound signaling word.</i>
key-variable loader	A device used to load encryption keys into a radio.
kHz	<i>See kilohertz.</i>
kilohertz	One thousand cycles per second. Used especially as a radio-frequency unit.
KVL	<i>See key-variable loader.</i>
LCD	<i>See liquid-crystal display.</i>
LED	<i>See LED.</i>
light emitting diode	An electronic device that lights up when electricity is passed through it.
liquid-crystal display	An LCD uses two sheets of polarizing material with a liquid-crystal solution between them. An electric current passed through the liquid causes the crystals to align so that light cannot pass through them.
LO	Local oscillator.
low-speed handshake	150-baud digital data sent to the radio during trunked operation while receiving audio.
LSH	<i>See low-speed handshake.</i>
Master In Slave Out	SPI data line from a peripheral to the MCU.
Master Out Slave In	SPI data line from the MCU to a peripheral.
MCU	<i>See microcontroller unit.</i>
MDC	Motorola Digital Communications.
MDI	MCU/DSP Interface internal to the Patriot IC.
MHz	<i>See Megahertz.</i>
Megahertz	One million cycles per second. Used especially as a radio-frequency unit.
microcontroller unit	Also written as μC . A microprocessor that contains RAM and ROM components, as well as communications and programming components and peripherals.
MISO	<i>See Master In Slave Out.</i>

Term	Definition
MOSI	<i>See Master Out Slave In.</i>
multiplexer	An electronic device that combines several signals for transmission on some shared medium (e.g., a telephone wire).
MUX	<i>See multiplexer.</i>
NiCd	Nickel-cadmium.
NiMH	Nickel-metal-hydride.
OMPAC	<i>See over-molded pad-array carrier.</i>
open architecture	A controller configuration that utilizes a microprocessor with extended ROM, RAM, and EEPROM.
oscillator	An electronic device that produces alternating electric current and commonly employs tuned circuits and amplifying components.
OSW	<i>See outbound signaling word.</i>
OTAR	<i>See over-the-air rekeying.</i>
outbound signaling word	Data transmitted on the control channel from the central controller to the subscriber unit.
over-molded pad-array carrier	A Motorola custom IC package, distinguished by the presence of solder balls on the bottom pads.
over-the-air rekeying	Allows the dispatcher to remotely reprogram the encryption keys in the radio.
PA	Power amplifier.
paging	One-way communication that alerts the receiver to retrieve a message.
Patriot IC	A dual-core processor that contains an MCU and a DSP in one IC package.
PC Board	Printed Circuit Board. Also referred to as a PCB.
phase-locked loop	A circuit in which an oscillator is kept in phase with a reference, usually after passing through a frequency divider.
PL	<i>See private-line tone squelch.</i>
PLL	<i>See phase-locked loop.</i>
private-line tone squelch	A continuous sub-audible tone that is transmitted along with the carrier. <i>See also DPL.</i>
Programmable Read-Only Memory	A memory chip on which data can be written only once. Once data has been written onto a PROM, it remains there forever.
PROM	<i>See Programmable Read-Only Memory.</i>

Term	Definition
PTT	<i>See Push-to-Talk.</i>
Push-to-Talk	The switch or button usually located on the left side of the radio which, when pressed, causes the radio to transmit. When the PTT is released, the unit returns to receive operation.
radio frequency	The portion of the electromagnetic spectrum between audio sound and infrared light (approximately 10 kHz to 10 GHz).
radio frequency power amplifier	Amplifier having one or more active devices to amplify radio signals.
Radio Interface Box	A service aid used to enable communications between a radio and the programming software.
Radio Service Software	DOS-based software containing the feature set of an ASTRO radio. <i>See also CPS.</i>
random access memory	A type of computer memory that can be accessed randomly; that is, any byte of memory can be accessed without touching the preceding bytes.
RAM	<i>See random access memory.</i>
read-only memory	A type of computer memory on which data has been prerecorded. Once data has been written onto a ROM chip, it cannot be removed and can only be read.
real-time clock	A module that keeps track of elapsed time even when a computer is turned off.
receiver	Electronic device that amplifies RF signals. A receiver separates the audio signal from the RF carrier, amplifies it, and converts it back to the original sound waves.
registers	Short-term data-storage circuits within the microcontroller unit or programmable logic IC.
repeater	Remote transmit/receive facility that re-transmits received signals in order to improve communications range and coverage (conventional operation).
repeater/talkaround	A conventional radio feature that permits communication through a receive/transmit facility, which re-transmits received signals in order to improve communication range and coverage.
RESET	Reset line: an input to the microcontroller that restarts execution.
RF	<i>See radio frequency.</i>
RF PA	<i>See radio frequency power amplifier.</i>
RIB	<i>See Radio Interface Box.</i>
ROM	<i>See read-only memory.</i>

Term	Definition
RPCIC	Regulator/power control IC.
RPT/TA	<i>See repeater/talkaround.</i>
RSS	<i>See Radio Service Software.</i>
RTC	<i>See real-time clock.</i>
RX	Receive.
RX DATA	Recovered digital data line.
SAP	<i>See Serial Audio CODEC Port.</i>
SCI IN	Serial Communications Interface Input line.
Serial Audio CODEC Port	SSI to and from the GCAP II IC CODEC used to transfer transmit and receive audio data.
Serial Communication Interface Input Line	A full-duplex (receiver/transmitter) asynchronous serial interface.
SCI IN	<i>See Serial Communication Interface Input Line.</i>
Serial Peripheral Interface	How the microcontroller communicates to modules and ICs through the CLOCK and DATA lines.
signal	An electrically transmitted electromagnetic wave.
Signal Qualifier mode	An operating mode in which the radio is muted, but still continues to analyze receive data to determine RX signal type.
softpot	<i>See software potentiometer.</i>
software	Computer programs, procedures, rules, documentation, and data pertaining to the operation of a system.
software potentiometer	A computer-adjustable electronic attenuator.
spectrum	Frequency range within which radiation has specific characteristics.
SPI	<i>See Serial Peripheral Interface.</i>
squelch	Muting of audio circuits when received signal levels fall below a pre-determined value. With carrier squelch, all channel activity that exceeds the radio's preset squelch level can be heard.
SRAM	<i>See static RAM.</i>
SRIB	Smart Radio Interface Box. <i>See RIB.</i>
SSI	<i>See Synchronous Serial Interface.</i>

Term	Definition
Standby mode	An operating mode in which the radio is muted but still continues to monitor data.
static RAM	A type of memory used for volatile, program/data memory that does not need to be refreshed.
Synchronous Serial Interface	DSP interface to peripherals that consists of a clock signal line, a frame synchronization signal line, and a data line.
system central controllers	Main control unit of the trunked dispatch system; handles ISW and OSW messages to and from subscriber units (<i>See ISW and OSW</i>).
system select	The act of selecting the desired operating system with the system-select switch (also, the name given to this switch).
thin small-outline package	A type of dynamic random-access memory (DRAM) package that is commonly used in memory applications.
time-out timer	A timer that limits the length of a transmission.
TOT	<i>See time-out timer.</i>
transceiver	Transmitter-receiver. A device that both transmits and receives analog or digital signals. Also abbreviated as XCVR.
transmitter	Electronic equipment that generates and amplifies an RF carrier signal, modulates the signal, and then radiates it into space.
TSOP	<i>See thin small-outline package.</i>
TX	Transmit.
UART	<i>See also Universal Asynchronous Receiver Transmitter.</i>
UHF	Ultra-High Frequency.
Universal Asynchronous Receiver Transmitter	A microchip with programming that controls a computer's interface to its attached serial devices.
Universal Serial Bus	An external bus standard that supports data transfer rates of 12 Mbps.
USB	<i>See Universal Serial Bus.</i>
VCO	<i>See voltage-controlled oscillator.</i>
vector sum excited linear predictive coding	A voice-encoding technique used in ASTRO digital voice.
VHF	Very-High Frequency.
VIP	Vehicle Interface Port.
VOCON	<i>See vocoder/controller.</i>

Term	Definition
vocoder	An electronic device for synthesizing speech by implementing a compression algorithm particular to voice. <i>See also voice encoder.</i>
vocoder/controller	A PC board that contains an ASTRO radio's microcontroller, DSP, memory, audio and power functions, and interface support circuitry.
voice encoder	The DSP-based system for digitally processing analog signals, and includes the capabilities of performing voice compression algorithms or voice encoding. <i>See also vocoder.</i>
voltage-controlled oscillator	An oscillator in which the frequency of oscillation can be varied by changing a control voltage.

Notes

Index

Numerics

800Mhz specifications xliii

A

ABACUS II IC, receiver back-end 3-7
 amplifier, power
 800 MHz band
 15-Watt 3-77
 35-Watt 3-77
 description 3-55
 troubleshooting
 800 MHz band 4-66
 UHF band 4-47
 VHF band 4-21
 UHF band
 40-Watt 3-72
 high-power 3-68
 VHF band
 25/10-Watt 3-59
 50-Watt 3-63
 high-power 3-55
 analog mode of operation 2-2
 assemblies, radio 2-1
 assembly
 command board 2-1, 2-7
 control-head 2-1, 2-2
 front-end receiver 2-1, 2-6
 power amplifier 2-1, 2-5
 RF board 2-1, 2-6, 3-1, 3-8
 VCO/buffer/divider board 2-1
 VOCON board
 components 2-1
 description 2-7
 Spectra 3-15
 Spectra Plus 3-38
 VOCON Plus board 2-1
 voltage-controlled oscillator (VCO) 2-6
 ASTRO mode of operation 2-2
 asynchronous buses, VOCON board
 Spectra 3-22
 Spectra Plus 3-43
 auxiliary control bits, synthesizer 3-5

B

B+ power routing 2-9
 board layouts, troubleshooting 7-1

C

charts, troubleshooting
 introduction 5-1
 list 5-1
 circuit protection, power amplifier assembly 2-5
 command board
 assembly

 components 2-1
 description 2-7
 encryption voltages 3-13
 external bus serial communications 3-11
 flash programming 3-13
 microcontroller and support ICs 3-8
 microphone audio 3-12
 power-up/-down sequence 3-9
 received audio 3-12
 regulator and power control IC 3-14
 regulators 3-10
 reset circuits 3-10
 RS-232 line drivers 3-13
 serial input/output IC 3-8
 synchronous serial bus 3-12
 transmit deviation 3-13
 component
 location diagrams listing 7-1
 parts lists 7-1
 control-head assembly
 backlight LEDs 2-3
 controls and indicators 2-3
 description 2-1, 2-2
 display
 W3 2-2
 W4, W5, W7 2-2
 W9 2-3
 ignition sense circuits 2-4
 power supplies 2-4
 status LEDs 2-3
 vacuum fluorescent
 display driver 2-3
 voltage source 2-3
 vehicle interface ports 2-4
 controller bootstrap, VOCON board
 Spectra 3-22
 Spectra Plus 3-43
 controller memory map, VOCON board, Spectra 3-24
 controller section, VOCON board
 Spectra 3-15
 Spectra Plus 3-38
 controls and indicators, control-head assembly 2-3
 copyrights
 computer software ii
 document ii

D

DC interconnect, power amplifier assembly 2-5
 DC power distribution 2-8
 diagnostics, power-up self-check, Spectra Plus 4-11
 display
 W3 2-2
 W4, W5, W7 2-2
 W9 2-3
 DSP system clock
 Spectra 3-28
 Spectra Plus 3-44

E

encryption modules
 circuit description A-2

- Spectra A-1
- Spectra Plus A-1
- encryption voltages, command board 3-13
- errors
 - 09/10 A-2
 - 09/90 A-2
 - power-up self-check
 - Spectra 4-2
 - Spectra Plus 4-10
- external bus serial communications, command board 3-11

F

- figures listing xiii
- first IF, receiver back-end 3-6
- first VCO frequency generation, synthesizer 3-3
- flash programming, command board 3-13
- frequency bands, radio 2-1
- front-end receiver assembly
 - components 2-1
 - description 2-6

G

- gain stages, power amplifier assembly 2-5
- glossary of terms Glossary-1

H

- handling precautions 4-1

I

- ignition sense circuits, control-head assembly 2-4
- introduction, manual 1-1

K

- keyload failure A-2

L

- LEDs
 - backlight 2-3
 - status 2-3
- list
 - component location diagrams 7-1
 - figures xiii
 - schematics 7-1
 - tables xiv
 - troubleshooting charts 5-1
 - waveforms 6-1
- loop filter, synthesizer 3-5

M

- manual
 - introduction 1-1
 - notations 1-2

- organization 1-1
- revisions ii
- MCU system clock
 - Spectra 3-28
 - Spectra Plus 3-44
- microcontroller and support ICs, command board 3-8
- microphone audio, command board 3-12
- mode
 - analog 2-2
 - ASTRO 2-2
- model chart
 - Spectra
 - 800MHz xxxii
 - motorcycle 15 Watt (ranges 1 and 2) xxii
 - motorcycle 15 Watt (ranges 3 and 3.5) xxiii
 - UHF 10-25 Watt xxvii
 - UHF 20-40 Watt xxviii
 - UHF 50-110 Watt xxx
 - VHF 10-25 Watt xxiv
 - VHF 10-25/50-110 Watt xxv
 - Spectra Plus
 - 800MHz xxxix
 - UHF 20-40 Watt xxxv
 - UHF 50-110 Watt xxxvii
 - VHF 25-50/50-110 Watt xxxiii
- model numbering scheme xxi

N

- notations, manual 1-2

O

- ordering replacement parts B-1
- organization, manual 1-1
- oscillator, voltage control (VCO)
 - 800 MHz band 3-50
 - description 3-47
 - UHF band 3-48
 - VHF band 3-47
- overview, radio 2-1

P

- parts lists 7-1
- parts, ordering replacement B-1
- phase modulator, synthesizer 3-5
- power
 - distribution
 - DC 2-8
 - synthesizer 3-6
 - routing, B+ 2-9
- power amplifier
 - 800 MHz band
 - 15-Watt 3-77
 - 35-Watt 3-77
 - assembly
 - circuit protection 2-5
 - components 2-1
 - DC interconnect 2-5
 - description 2-5
 - gain stages 2-5
 - power control 2-5

- description 3-55
- troubleshooting
 - 800 MHz band 4-66
 - UHF band 4-47
 - VHF band 4-21
- UHF band
 - 40-Watt 3-72
 - high-power 3-68
- VHF band
 - 25/10-Watt 3-59
 - 50-Watt 3-63
 - high-power 3-55
- power control, power amplifier assembly 2-5
- power supplies, control-head assembly 2-4
- power-up self-check
 - diagnostics, Spectra Plus 4-11
- errors
 - Spectra 4-2
 - Spectra Plus 4-10
- power-up/-down sequence, command board 3-9
- power-up/power-down sequence, radio
 - Spectra 3-28
 - Spectra Plus 3-46
- product safety information ii
- programmable reference divider, synthesizer 3-4
- publications, related xv

R

- radio
 - 800 MHz voltage-controlled oscillator assembly 2-7
 - B+ power routing 2-9
 - command board assembly
 - components 2-1
 - description 2-7
 - theory of operation 3-8
 - control-head assembly 2-1, 2-2
 - DC power distribution 2-8
 - frequency bands 2-1
 - front-end receiver assembly 2-1, 2-6
 - overview 2-1
 - power amplifier assembly 2-1, 2-5
 - RF board assembly
 - components 2-1
 - description 2-6
 - receiver back-end circuitry 3-6
 - synthesizer circuitry 3-3
 - theory of operation 3-1
 - UHF voltage-controlled oscillator assembly 2-7
 - VCO/buffer/divider board assembly 2-1
 - VHF voltage-controlled oscillator assembly 2-6
 - VOCON board assembly
 - asynchronous buses
 - Spectra 3-22
 - Spectra Plus 3-43
 - components 2-1
 - controller bootstrap
 - Spectra 3-22
 - Spectra Plus 3-43
 - controller memory map, Spectra 3-24
 - controller section
 - Spectra 3-15
 - Spectra Plus 3-38

- description 2-7
- DSP system clock
 - Spectra 3-28
 - Spectra Plus 3-44
- MCU system clock
 - Spectra 3-28
 - Spectra Plus 3-44
- power-up/power-down sequence
 - Spectra 3-28
 - Spectra Plus 3-46
- RX signal path
 - Spectra 3-18
 - Spectra Plus 3-41
- serial peripheral interface (SPI) bus
 - Spectra 3-24
 - Spectra Plus 3-44
- signals, Spectra 3-29
- theory of operation
 - Spectra 3-15
 - Spectra Plus 3-38
- TX signal path
 - Spectra 3-21
 - Spectra Plus 3-42
- vocoder bootstrap, Spectra 3-24
- vocoder memory map, Spectra 3-26
- vocoder section
 - Spectra 3-17
 - Spectra Plus 3-39
- voltage regulators, Spectra Plus 3-45
- VOCON Plus board assembly 2-1
- voltage-controlled oscillator (VCO) assembly 2-6
- received audio, command board 3-12
- receiver
 - back-end
 - ABACUS II IC 3-7
 - first IF 3-6
 - front-end
 - 800 MHz band 3-54
 - description 3-53
 - troubleshooting
 - 800 MHz band 4-20
 - UHF band 4-20
 - VHF band 4-20
 - UHF band 3-53
 - VHF band 3-53
- reference frequency generation, synthesizer 3-3
- regulator and power control IC, command board 3-14
- regulators, command board 3-10
- related publications xv
- replacement parts, ordering B-1
- reset circuits, command board 3-10
- RF board assembly
 - components 2-1
 - description 2-6
 - theory of operation 3-1, 3-8
- RF board troubleshooting 4-5
- RF exposure compliance information ii
- RS-232 line drivers, command board 3-13
- RX signal path, VOCON board
 - Spectra 3-18
 - Spectra Plus 3-41

S

schematics
 listing 7-1
 troubleshooting 7-1
 second VCO, synthesizer 3-6
 secure modules
 circuit description A-2
 Spectra A-1
 Spectra Plus A-1
 secure operations
 errors A-2
 keyload failure A-2
 serial input/output IC, command board 3-8
 signal tracing procedures 4-2
 specifications
 800MHz xliii
 UHF xlii
 VHF xli
 SPI bus, VOCON board
 Spectra 3-24
 Spectra Plus 3-44
 standard bias table
 Spectra 4-9
 Spectra Plus 4-12
 synchronous serial bus, command board 3-12
 synthesizer
 auxiliary control bits 3-5
 first VCO frequency generation 3-3
 loop filter 3-5
 phase modulator 3-5
 power distribution 3-6
 programmable reference divider 3-4
 reference frequency generation 3-3
 second VCO 3-6

T

tables listing xiv
 theory of operation
 command board description 3-8
 RF board
 description 3-1
 receiver back-end circuitry 3-6
 synthesizer circuitry 3-3
 VOCON board
 asynchronous buses
 Spectra 3-22
 Spectra Plus 3-43
 controller bootstrap
 Spectra 3-22
 Spectra Plus 3-43
 controller memory map, Spectra 3-24
 controller section
 Spectra 3-15
 Spectra Plus 3-38
 description
 Spectra 3-15
 Spectra Plus 3-38
 DSP system clock
 Spectra 3-28
 Spectra Plus 3-44
 MCU system clock

Spectra 3-28
 Spectra Plus 3-44
 power-up/power-down sequence
 Spectra 3-28
 Spectra Plus 3-46
 RX signal path
 Spectra 3-18
 Spectra Plus 3-41
 serial peripheral interface (SPI) bus
 Spectra 3-24
 Spectra Plus 3-44
 signals, Spectra 3-29
 TX signal path
 Spectra 3-21
 Spectra Plus 3-42
 vocoder bootstrap, Spectra 3-24
 vocoder memory map, Spectra 3-26
 vocoder section
 Spectra 3-17
 Spectra Plus 3-39
 voltage regulators, Spectra Plus 3-45
 trademark information ii
 transmit deviation, command board 3-13
 troubleshooting
 charts
 introduction 5-1
 list 5-1
 procedures
 handling precautions 4-1
 power amplifier
 800 MHz band 4-66
 UHF band 4-47
 VHF band 4-21
 power-up self-check diagnostics, Spectra Plus 4-11
 receiver front-end
 800 MHz band 4-20
 UHF band 4-20
 VHF band 4-20
 RF board 4-5
 signal tracing 4-2
 standard bias table
 Spectra 4-9
 Spectra Plus 4-12
 VCO
 800 MHz band 4-18
 Spectra 4-12
 UHF band 4-15
 VHF band 4-13
 voltage measurement procedures 4-2
 schematics, board layouts, and parts lists 7-1
 secure operations
 errors A-2
 keyload failure A-2
 waveforms
 ASTRO Spectra 6-2
 ASTRO Spectra Plus 6-7
 TX signal path, VOCON board
 Spectra 3-21
 Spectra Plus 3-42

U

UHF specifications xlii

V

vacuum fluorescent
 display driver 2-3
 voltage source 2-3
VCO (voltage-controlled oscillator assembly) 2-6
VCO troubleshooting
 800 MHz band 4-18
 Spectra 4-12
 UHF band 4-15
 VHF band 4-13
VCO/buffer/divider assembly 2-1
vehicle interface ports 2-4
VHF specifications xli
vocoder bootstrap, VOCON board, Spectra 3-24
vocoder memory map, VOCON board, Spectra 3-26
vocoder section, VOCON board
 Spectra 3-17
 Spectra Plus 3-39
VOCON board assembly
 asynchronous buses
 Spectra 3-22
 Spectra Plus 3-43
 components 2-1
 controller bootstrap
 Spectra 3-22
 Spectra Plus 3-43
 controller memory map, Spectra 3-24
 controller section
 Spectra 3-15
 Spectra Plus 3-38
 description 2-7
 DSP system clock
 Spectra 3-28
 Spectra Plus 3-44
 MCU system clock
 Spectra 3-28
 Spectra Plus 3-44
 power-up/power-down sequence
 Spectra 3-28
 Spectra Plus 3-46
 RX signal path
 Spectra 3-18
 Spectra Plus 3-41
 signals, Spectra 3-29
 SPI bus
 Spectra 3-24
 Spectra Plus 3-44
 theory of operation
 Spectra 3-15
 Spectra Plus 3-38
 TX signal path
 Spectra 3-21
 Spectra Plus 3-42
 vocoder bootstrap, Spectra 3-24
 vocoder memory map, Spectra 3-26
 vocoder section
 Spectra 3-17
 Spectra Plus 3-39
 voltage regulators, Spectra Plus 3-45

VOCON Plus board assembly 2-1
voltage control oscillator (VCO)
 800 MHz band 3-50
 description 3-47
 UHF band 3-48
 VHF band 3-47
voltage regulators, Spectra Plus 3-45
voltage-controlled oscillator (VCO) assembly
 800 MHz radios 2-7
 description 2-6
 UHF radios 2-7
 VHF radios 2-6

W

warranty information xvii
waveforms listing 6-1
waveforms, troubleshooting
 ASTRO Spectra 6-2
 ASTRO Spectra Plus 6-7

Notes



Motorola, Inc.
8000 West Sunrise Boulevard
Ft. Lauderdale, FL 33322

MOTOROLA, the Stylized M Logo, ASTRO, and Spectra are registered in the U.S. Patent and Trademark Office. All other product or service names are the property of their respective owners.
© Motorola, Inc. 2002.
All rights reserved. Printed in U.S.A.



6881076C25-D