

LBI-31295D

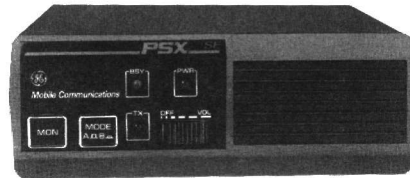

Mobile Communications



PHOENIX™ SX, PSX200 & PSX_SE

Installation Manual

UNPACKING AND CHECKING EQUIPMENT

Carefully unpack the Two-Way Radio. It is recommended that you identify the items ordered and check them off in the box below before discarding the packing material. If any damage has occurred to the equipment during shipment, file a claim with the carrier immediately.

EQUIPMENT & OPTIONS

- | | | | |
|---|--------------------------|---|--------------------------|
| Two-Way Radio | <input type="checkbox"/> | Channel Guard Hookswitch 19C320318G4 | <input type="checkbox"/> |
| Microphone & Hanger 19C850857P2 (PSX) | <input type="checkbox"/> | Antenna, Cable and RF Connector | <input type="checkbox"/> |
| 19B801398P3 (PHOENIX) | | | |
| Mounting Hardware Kit 19A138051G6 (SX Comb.) | <input type="checkbox"/> | Speaker, External 19C850550G1/G2 | <input type="checkbox"/> |
| Mounting Hardware Kit 19A170522G10
(TRK Comb.) | <input type="checkbox"/> | Desk Top Stand &
Mounting Hardware 19A138051G8 | <input type="checkbox"/> |
| Power Cable with System Plug 19B232925G3 | <input type="checkbox"/> | Tuning Tool 19B800716P2 | <input type="checkbox"/> |
| Ignition Switch Control Cable 19A137818G10/11 | <input type="checkbox"/> | | |

It is suggested that you take advantage of the experience of one of the many authorized General Electric Service Stations located throughout the United States by having them install your Two-Way Radio and make the final adjustments.

WARNING

Interference with Vehicular Electronics — Electronic fuel injection systems, electronic anti-skid braking systems, electronic cruise control systems, etc., are typical of the types of electronic devices which may be prone to malfunction due to the lack of protection from radio frequency energy present when transmitting. If the vehicle contains such equipment, consult the dealer for the make of vehicle and enlist his aid in determining if such electronic circuits will perform normally when the radio is transmitting.

RADIOS INSTALLED IN VEHICLES POWERED BY LIQUEFIED (LP) GAS

WARNING

Radio installations in vehicles powered by liquefied petroleum gas must conform to the following requirements.

Radio installations in vehicles powered by liquefied petroleum gas with the LP-gas container in the trunk or other sealed-off space within the interior of the vehicle must conform to the National Fire Protection Association Standard NFPA 58 which requires that:

- Space containing radio equipment shall be isolated by a seal from the space containing the LP-gas container and its fittings.
- Outside filling connections shall be used for the LP-gas container.
- The LP-gas container space shall be vented to the outside of the vehicle.

PLANNING THE INSTALLATION

The accompanying illustrations should help you in planning your installation. Before starting, plan your installation carefully—so that it will be convenient for the operator to use, neat, protected from water damage, easy to service, and out of the way of auto mechanics and passengers.

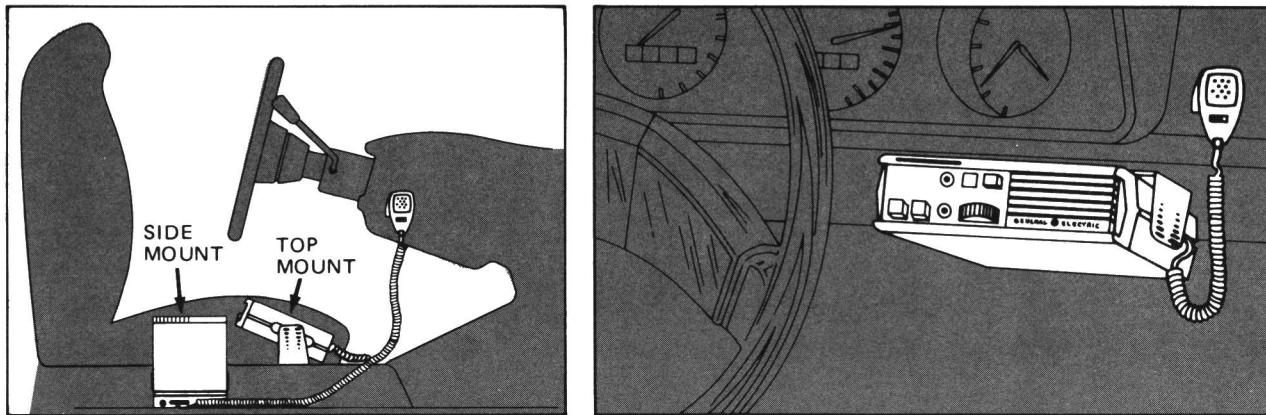

Figure 1 — Typical Hump or Console Mount — Typical Dash Mount

INSTALLATION EQUIPMENT

The equipment required for installing the Two-Way Radio includes:

- An electric drill for drilling mounting holes
- Drills and circle cutters (see sizes in box below)
- A soldering iron for the antenna cable
- Phillips and PoziDriv® screwdrivers and a 7 mm hex head driver for mounting screws

DRILL SIZES

No. 31 (1/8 inch) Drill for No. 8 Self-Tapping Screws

No. 36 (7/64-inch) for No. 6 Self-Tapping Screws

3/4-Inch Punch or Holesaw for 146—470 MHz Antenna (optional)

3/8-Inch Punch or Punch for rubber grommet.

POWER AND IGNITION CABLE

The Power Cable consists of a fused yellow lead, a black lead, and a 11-pin systems plug (see Figure 2). To install the Power Cable, start with the plug end of the Cable at the location of the radio and run the two leads to the firewall, drill a 5/8-inch hole and insert the rubber grommet provided. Connect the yellow fused lead to the positive (+) battery terminal, and the black to the negative (-) battery terminal. Always locate the fuse as close to the battery as possible. Coil up the surplus cable and secure it out of the way with the retaining strap provided. Be sure to leave some slack in the cables going to the radio so that it may be pulled out for servicing with the power applied.

With ignition switch control, the transmitter and receiver operate only with the ignition switch in the Accessory or On position. To install the cable, connect the red lead to System Plug P910-1 (see Figure 2). Connect the red fused lead to the ignition switch terminal. Then remove the jumper between HL1 and HL2 on the Interconnect/Oscillator/Channel Guard board.

NOTE

The mobile combination operates in 12-volt negative ground systems only! Always check the battery polarity and voltage of the vehicle before installing the radio.

NOTE: ALWAYS CONNECT THE ORANGE LEAD DIRECTLY TO THE BATTERY. DO NOT CONNECT TO A SWITCHED SUPPLY VOLTAGE.

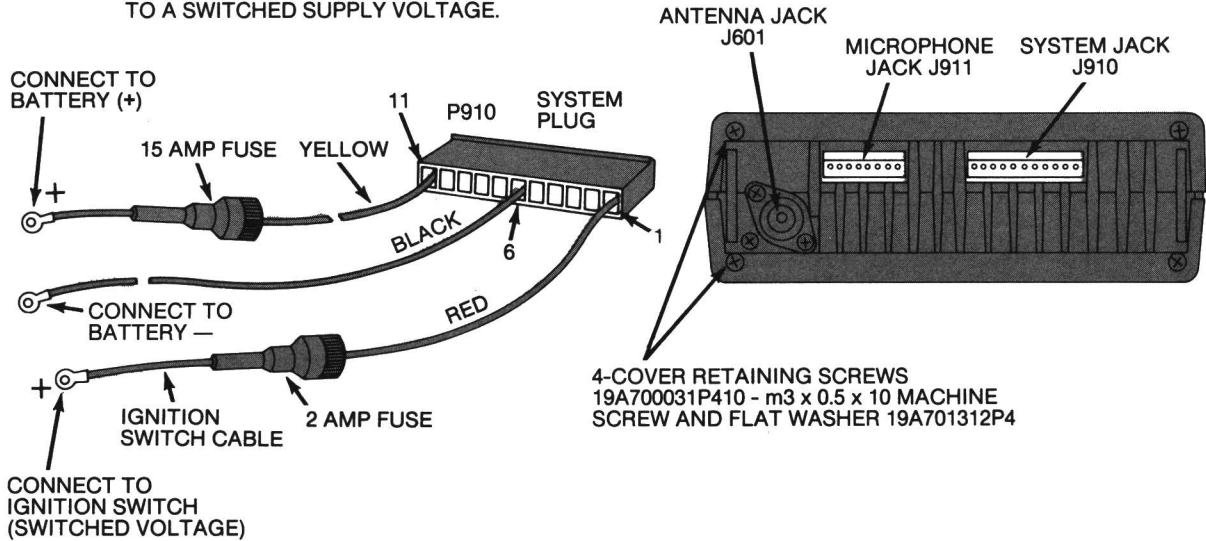

Figure 2 — Power Cable and Systems Plug

INSTALLING THE RADIO

Mount the Two-Way Radio so that the controls are within reach of the operator. Use the mounting bracket as a template to locate the holes, and mount the radio as shown in Figure 3. Be sure to leave enough room at the rear of radio for cable connections. Before attaching the radio in the mounting brackets, connect the antenna plug, systems plug and microphone.

WARNING

For passenger safety, mount the radio securely so that the unit will not break loose in the event of a collision. This is especially important in station wagons, vans and similar type installations where a loose radio could be extremely dangerous to the vehicle occupants.

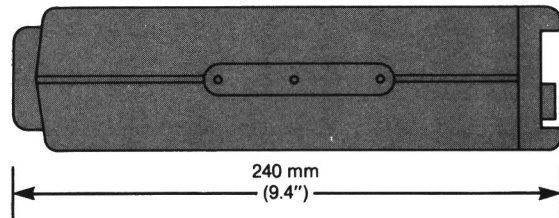
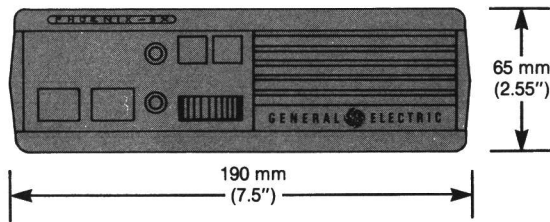

Figure 3 — Mounting Dimensions

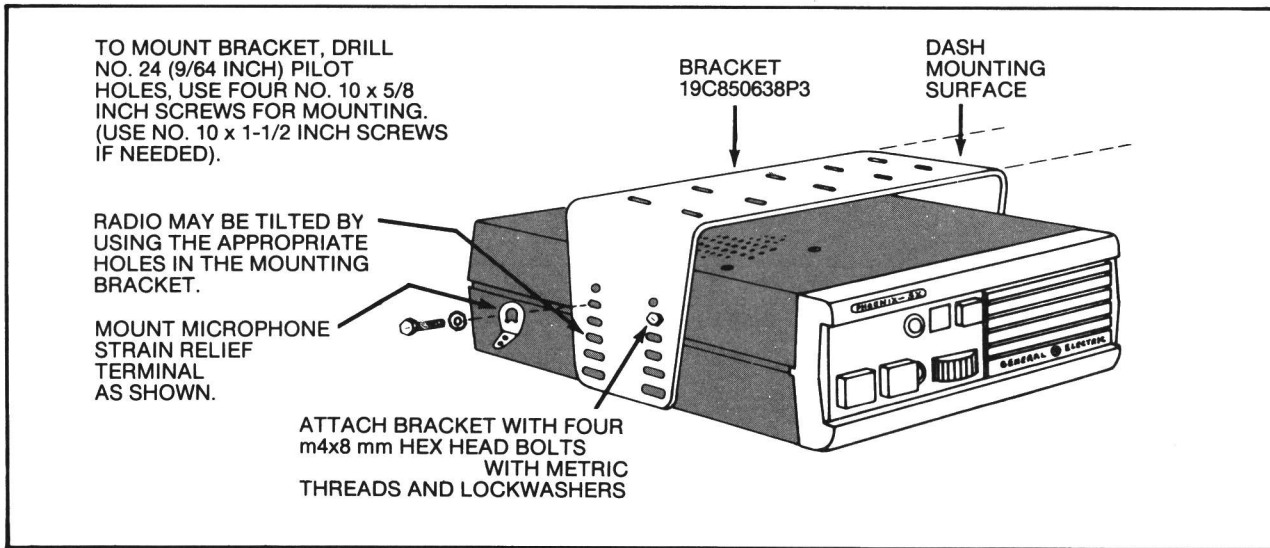

Figure 4 — Installing Mounting Bracket

CAUTION

Be careful to avoid damaging some vital part (fuel tank, transmission housing, etc.) of the vehicle when drilling mounting holes. Always check to see how far the mounting screws will extend below the mounting surface before installing.

DESK MICROPHONE

Microphone 19B209694 has a green wire connected to P911-5 on the microphone plug. In Channel Guard applications, connect the green wire to P910-9.

MOBILE MICROPHONE

Mount the microphone where it will be within easy reach of the operator, but will not interfere with safe operation of the vehicle. After the microphone bracket is mounted, connect the microphone plug into the microphone jack on the rear of the radio and connect the strain relief to the terminal shown.

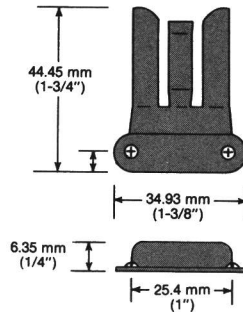
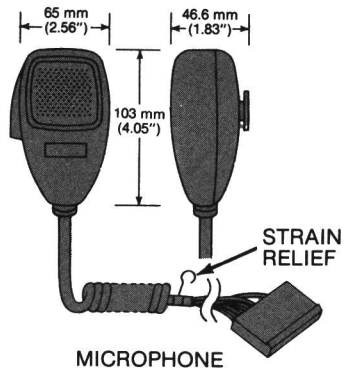

MICROPHONE BRACKET

DRILL MOUNTING HOLES WITH NO. 31 (1/8-INCH)
 DRILL. MOUNT BRACKET WITH TWO NO. 8 x 1/2"
 SCREWS.

Figure 5 — Microphone Bracket Mounting

EXTERNAL SPEAKER (OPTIONAL)

The speaker should be mounted where it will direct sound to the operator, but not interfere with his vision or provide a hazard to passengers in case of an accident. The speaker may be mounted on the lower edge of the instrument panel, on the firewall, above the windshield in some trucks, or behind the build-in speaker grille in some vehicles. Use the mounting bracket as a template for locating the mounting holes, and mount the speaker as shown in Figure 6. Remove the top cover of the radio and remove jumper W903 (or disconnect the speaker connector) on the Interconnect/Oscillator/Channel Guard board to disable the internal speaker. Refer to the applicable maintenance manual for additional information when the external speaker is used with other options; eg. public address etc. Connect external speaker wires to P910-7 (Speaker Lo) and (P910-3 (Speaker Hi). In Station Applications where the Power Supply is used, remove jumper connected between P801-3 and 10 on power supply cable and connect the speaker leads to P801-3 and P801-7.

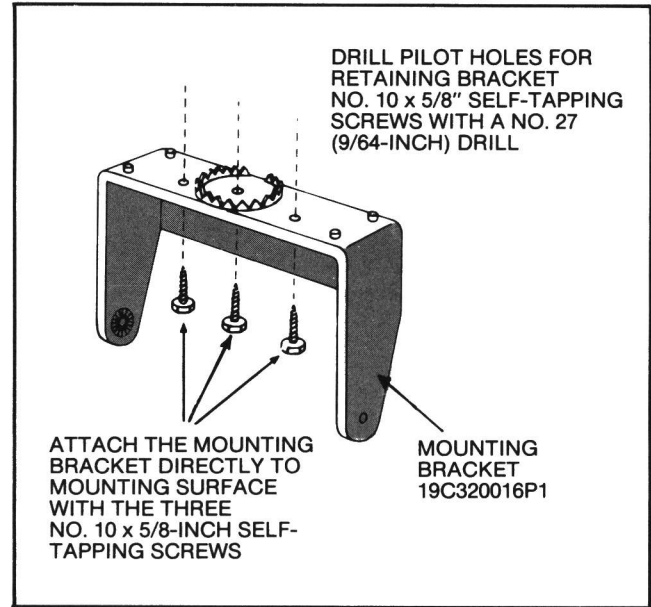

Figure 6 — Mounting the Speaker

CHANNEL GUARD AUTOMATIC MONITORING HOOKSWITCH (OPTIONAL)

For Channel Guard applications with Automatic Monitoring, a hookswitch is used in place of the microphone bracket. Mount the hookswitch as shown in Figure 7. After mounting the hookswitch, connect the two pins to holes 8 and 9 on System Plug P910.

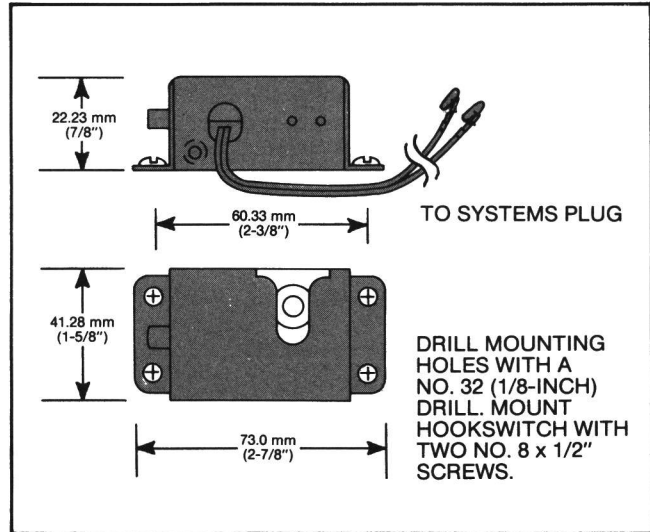

Figure 7 — Hookswitch Mounting

CHANNEL GUARD DISABLE

Channel Guard encode and decode functions are software programmable and deprogrammable on a per channel basis using the General Electric TQ2310 or 4EX22A10 Universal Programmers.

Alternately, the Channel Guard decode function can be disabled for all channels by grounding J910-9. The encode function can be disabled on all channels by turning CG DEV ADJ control R724 full ccw, so that the CG HI line is effectively grounded.

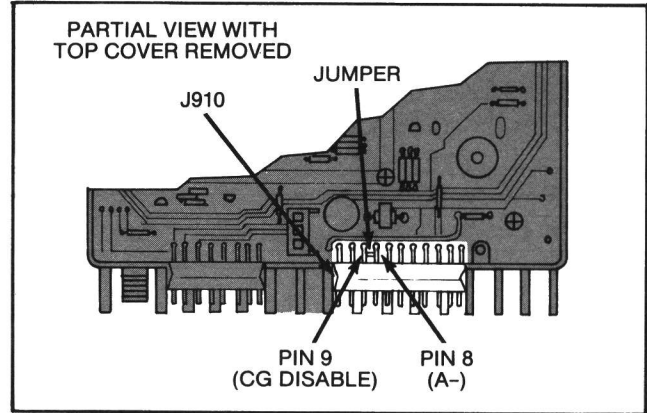

Figure 8 — Disabling the Channel Guard Decoder

AC POWER SUPPLIES (OPTIONAL)

The rubber feet supplied with the AC power supply should be applied to the bottom of the supply. These feet protect the surface on which the units are located.

To install the feet, remove the backing strip and apply the adhesive side of the feet to the bottom corners of the power supply. The feet should be approximately one-half inch from the edge.

After positioning the radio and power supply, install the ground wire as shown in Figure 12. This grounding will help protect operators and equipment from injury or damage during lightning storms.

An eight-foot power cable is provided to allow for remote power supply location. Connect the power supply jack to the radio and AC line cord to AC source.

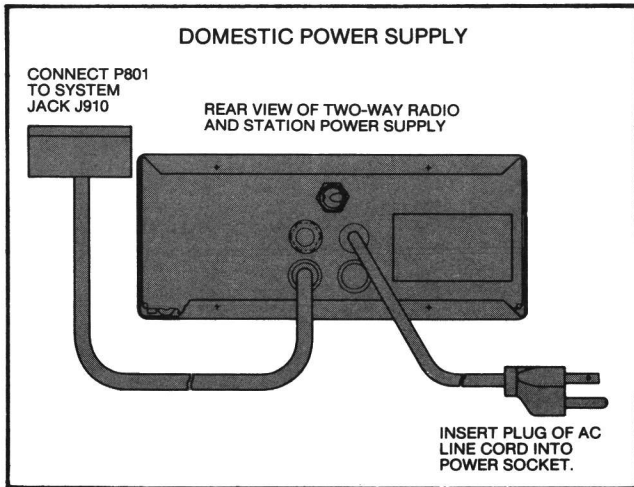

Figure 9 — Installing Power Supply

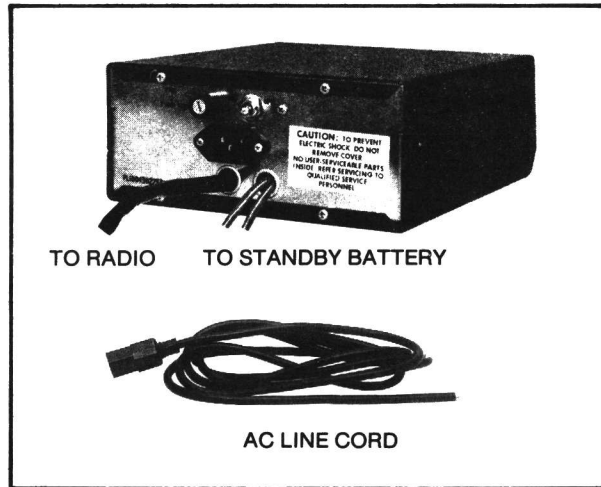
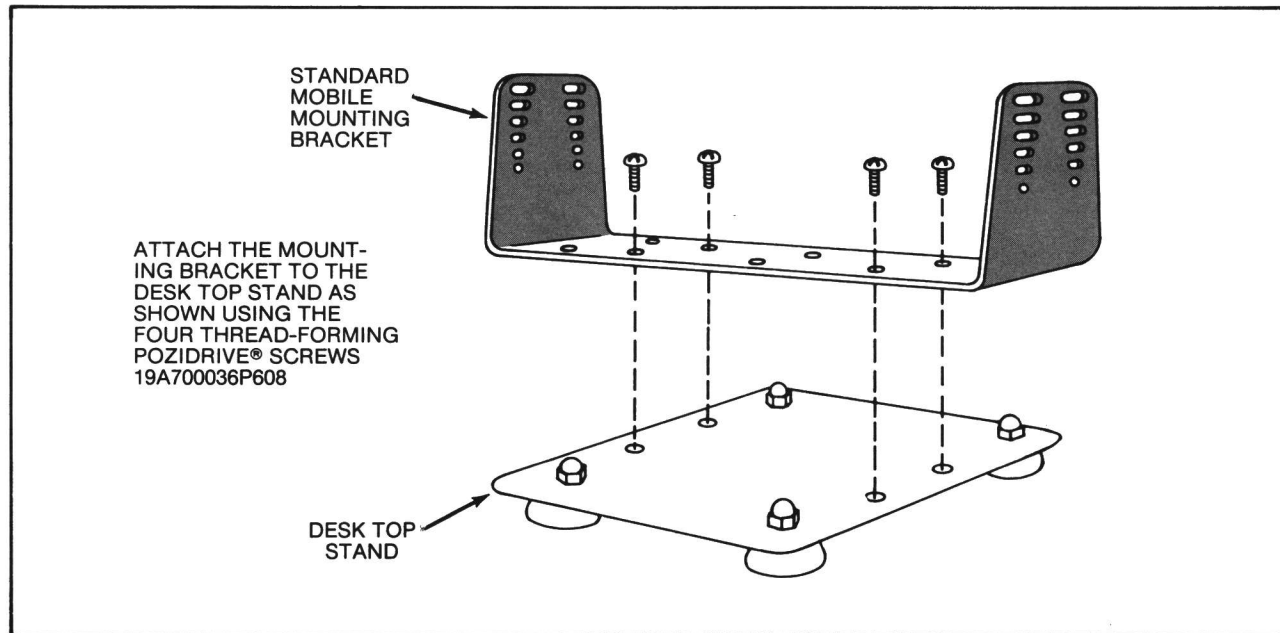

Figure 10 — International Power Supply

DESK TOP STAND (OPTIONAL)



Place radio in desk top stand and align mounting holes. Insert the lockwashers and four m4x8 hex head bolts through the mounting bracket and secure radio. Before tightening bolts, position radio to the desired upward angle for the operator's convenience. After mounting the radio, press radio down on mounting surface to engage suction cups.

The desk top stand is normally used in station applications and is used with the standard mobile mounting bracket.

Complete the installation by connecting the microphones, antenna, power cable and ground cable.

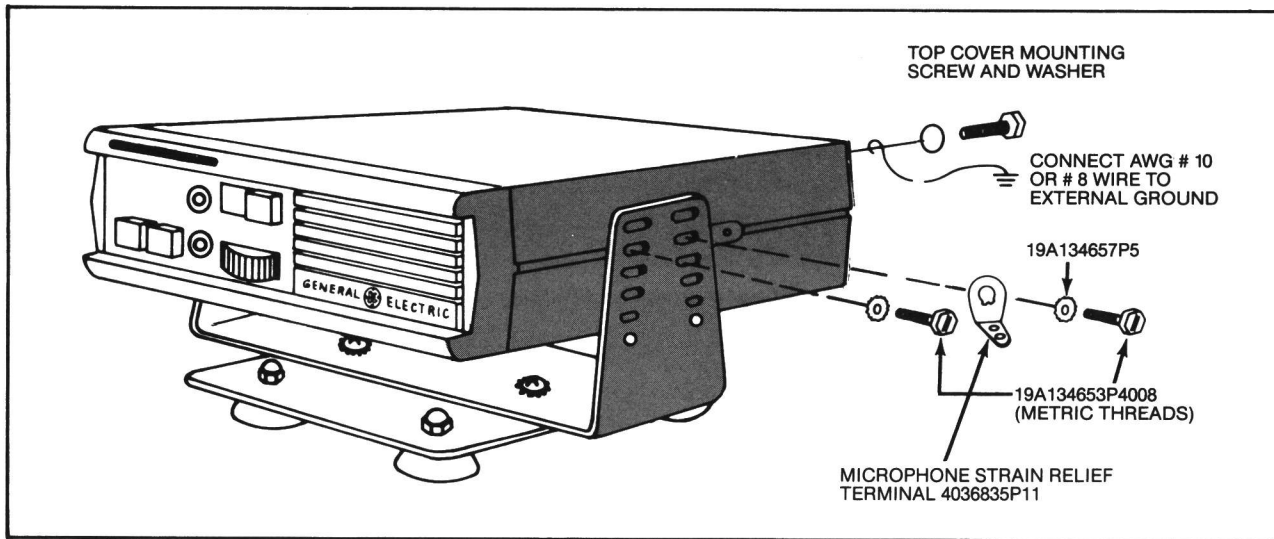

Figure 12 — Desk Top Stand with Radio

ANTENNA (OPTIONAL)

Installation instructions for the antenna are packaged with the antenna. The antenna must be installed in accordance with good engineering practice for optimum results.

The most effective mounting position for the antenna is usually in the center of the roof of the vehicle. The antenna cable will normally run from the rear of the Two-Way Radio, behind sections of the interior trim to a door or window post, and then up between the roof and headliner in the passenger compartment to the antenna base.

Try to route the cable away from locations where it will be exposed to heat, sharp edges or mechanical damage, and where it will be out of the way of the driver, passengers or vehicle mechanics. Wherever possible, existing holes in the trunk wall, and the channels above or beneath doors and window columns should be utilized.

CAUTION

In station applications, the radio will not operate properly with the antenna mounted directly on the back of the radio. Always mount the antenna at least five feet from the radio.

PLACING THE TWO-WAY RADIO IN OPERATION

After completing the installation of the Two-Way Radio, the following operations should be performed:

FOR U.S. INSTALLATIONS:

Have an electronics technician make the final adjustments. The adjustments include:

Transmitter: Measure Forward and Reflected power and adjust antenna length for optimum ratio. Set transmitter to rated power output. Measure the frequency and modulation and record these measurements for future reference.

Vehicle: Check to see if any electrical noise suppression is needed.

Instructions for making these adjustments are included in the Maintenance Manual for the Two-Way Radio.

Fill out and mail the "ON ARRIVAL" Information Card.

Give the Operator's Manual for the Two-Way Radio to the person who is going to operate it, or place the Manual in the vehicle where he will find it.

FOR INTERNATIONAL INSTALLATIONS:

Same as above except the installation must conform to the regulations of the country where the equipment is installed.

Where "on arrival" information card is provided, please return it to authorized Representative or distributor of GE Mobile Radio products servicing the country or region where the radio equipment is used.



Ericsson GE Mobile Communications Inc.
Mountain View Road • Lynchburg, Virginia 24502