



SERVICE SECTION

136-174 MHz PHOENIX-SX TWO-WAY FM RADIO (WIDEBAND)

TABLE OF CONTENTS

DESCRIPTION	Page
DESCRIPTION	1
INITIAL ADJUSTMENT	1
MAINTENANCE	2
Preventive Maintenance	2
Disassembly	2
Driver and PA Replacement	3
Chip Component Replacement	3
Integrated Circuit Removal	5
TEST AND TROUBLESHOOTING PROCEDURES	5
Servicing Techniques	6
Microcomputer Diagnostics	6
PA Troubleshooting	11
Transmitter Alignment	12
Receiver Alignment	13
Receiver Test Procedures	14
Receiver Audio Checks	15
MECHANICAL LAYOUT	16
SYSTEM INTERCONNECTION DIAGRAMS	17-18
INSTALLATION DIAGRAMS	19-21
PARTS LIST	22-24

DESCRIPTION

The Service Section contains dis-assembly procedures, procedures for replacing PA transistors, Integrated Circuits and chip components. Also included are Alignment Procedures, Option Modifications, and Troubleshooting information (See Table of Contents).

INITIAL ADJUSTMENT

After the radio has been installed (as described in the Installation Manual), the following adjustments should be made by a certified electronics technician.

TRANSMITTER ADJUSTMENT

The transmitter is factory preset and should require no readjustment. However, the antenna length should be adjusted for optimum VSWR. Next, measure the frequency and modulation and record these measurements for future reference. For the complete transmitter adjustment, refer to the Alignment Procedure (See Table of Contents).

RECEIVER ADJUSTMENT

No initial adjustments to the receiver are required.

CHANNEL GUARD DISABLE/DIGITAL CODE POLARITY REVERSAL

All radios are equipped with Channel Guard. In applications where Channel Guard is not desired, disable the Channel Guard circuit by connecting a jumper from J910-8 to J910-9.

Depending on system applications, the polarity of the digital code may need to be reversed. Refer to the Installation Diagram and Schematic Diagram for instructions.

RE-INSTALLATION

If the mobile combination is moved to a different vehicle, check battery polarity. Phoenix-SX radios are negative ground only.

EQUIPMENT MODIFICATIONS

When replacing boards care should be taken to assure boards with gold contacts are not intermixed with boards having tin contacts. Replace only with same group number as the original.

OPTION

Modifications to the synthesizer/interconnect board are required to maintain compatibility with tone, public address, and other options. These modifications involve the addition and/or

deletion of jumpers. Refer to the Installation and Schematic Diagrams for modification data, especially if the option is installed in the field.

DISASSEMBLY

- To service the transmitter/receiver (Tx-Rx) board, loosen the two screws securing the bottom cover at the rear of the radio. Then slide the cover out from under the edge of the front control panel and lift off.
- To service the synthesizer/interconnect board, loosen the two screws securing the top cover at the rear of the radio and slide the cover out from the edge of the front control panel and lift off.

MAINTENANCE

PREVENTIVE MAINTENANCE

To insure high operating efficiency and to prevent mechanical and electrical failures from interrupting system operations, routine checks should be made of all mechanical and electrical parts at regular intervals. This preventive maintenance should include the checks as listed in the Table of Maintenance Checks.

MAINTENANCE CHECKS	INTERVAL	
	6 Months	As Required
CONNECTIONS - Ground connections and connections to the voltage source should be periodically checked for tightness. Loose or poor connections to the power source will cause excessive voltage drops and faulty operation. When ground connections are not made directly to the battery, the connection from the battery to vehicle chassis must be checked for low impedance. A high impedance may cause excessive voltage drops and alternator noise problems.	X	
ELECTRICAL SYSTEM - Check the voltage regulator and alternator or generator periodically to keep the electrical system within safe and economical operating limits. Over-voltage is indicated when the battery loses water rapidly. Usage of 1 or 2 ounces of water per cell per week is acceptable for batteries in continuous operation. A weak battery will often cause excessive noise or faulty operation.		X
MECHANICAL INSPECTION - Since mobile units are subject to constant shock and vibration, check for loose plugs, nuts, screws and parts to make sure that nothing is working loose. Be sure that all screws are properly torqued.	X	
ANTENNA - The antenna, antenna base and all contacts should be kept clean and free from dirt or corrosion. If the antenna or its base should become coated or poorly grounded, loss of radiation and a weak signal will result.	X	
ALIGNMENT - The transmitter and receiver voltage readings should be checked periodically, and the alignment "touched-up" when necessary. Refer to applicable Alignment Procedure and troubleshooting sheet for typical voltage readings.		X
FREQUENCY CHECK - Check transmitter frequency and deviation, as required by FCC. Normally, these checks are made when the unit is first put into operation, after the first six months and once a year thereafter.		X

- To remove the Tx-Rx board:
 1. Remove the top and bottom covers.
 2. Remove the four screws securing the front panel to the "H" frame and remove the front panel. See Figure 1. Also, remove screws securing display board (if present) to front panel.
 3. Remove the eight screws securing the RF shield. See Figure 1.
 4. Remove the antenna connector by removing two retaining screws and unsoldering the center conductor.
 5. Remove the four screws securing PA transistors.
 6. Remove the 9 screws securing the Tx-Rx board and carefully lift up the board off of the interconnection pins.
 - To remove the synthesizer/interconnect board:
 1. Remove the top cover.
 2. Remove the four screws in the front control panel and remove panel. See Figure 2. Also, remove screws securing display board (if present) to front panel.
 3. Remove the 14 or 16 screws securing the board and carefully lift the board up to disconnect the interconnection pins.
2. Unsolder one lead at a time with a 50 watt soldering iron. Use a scribe or X-acto® knife to hold the lead away from the printed circuit board until the solder cools.
 3. Lift out the transistor, and remove the old solder from the printed circuit board with a vacuum desoldering tool. Special care should be taken to prevent damage to the printed circuit board runs because part of the matching network is included in the base and collector runs.
 4. Trim the new transistor leads (if required) to the lead length of the removed transistor. The letter "C" on the top of the transistor indicates the collector (See Figure 3).
 5. Apply a coat of silicon grease to the transistor mounting surface and to both sides of the transistor block (Q202) and the insulator (Q204). Place the transistor in the mounting hole. Align the leads as shown on the Outline Diagram. Then replace the transistor mounting screws using a moderate torque of 0.5 Newton meters (N/m) or 4.5 inch pounds for the M2.5 x 8 screws (Q203).
 6. Solder the leads to the printed circuit pattern. Start at the inner edge of mounting hole and solder the remaining length of transistor lead to the board. Solder must form a complete fillet on both sides of the transistor.

DRIVER AND PA TRANSISTOR REPLACEMENT

WARNING

The flange-mounted RF Power Transistors used in the transmitter contain Beryllium Oxide, a TOXIC substance. If the ceramic or other encapsulation is opened, crushed, broken or abraded, exercise caution since the dust may be hazardous if inhaled. Use care in replacing transistors of this type.

CAUTION

Failure to solder the transistor leads as directed may result in the generation of RF loops that could damage the transistor or cause low power output.

To replace PA RF transistors:

1. Remove the transistor mounting hardware.

NOTE

Use care not to use excessive heat that causes the printed wire board runs to lift up from the board. Check for shorts and solder bridges before applying power.

REPLACING CHIP COMPONENTS

Replacement of chip capacitors should always be done with a temperature-controlled soldering iron, using a controlled temperature of 700°F (371°C). However, do NOT touch black metal film of the resistors or the ceramic body of capacitors with the soldering iron.

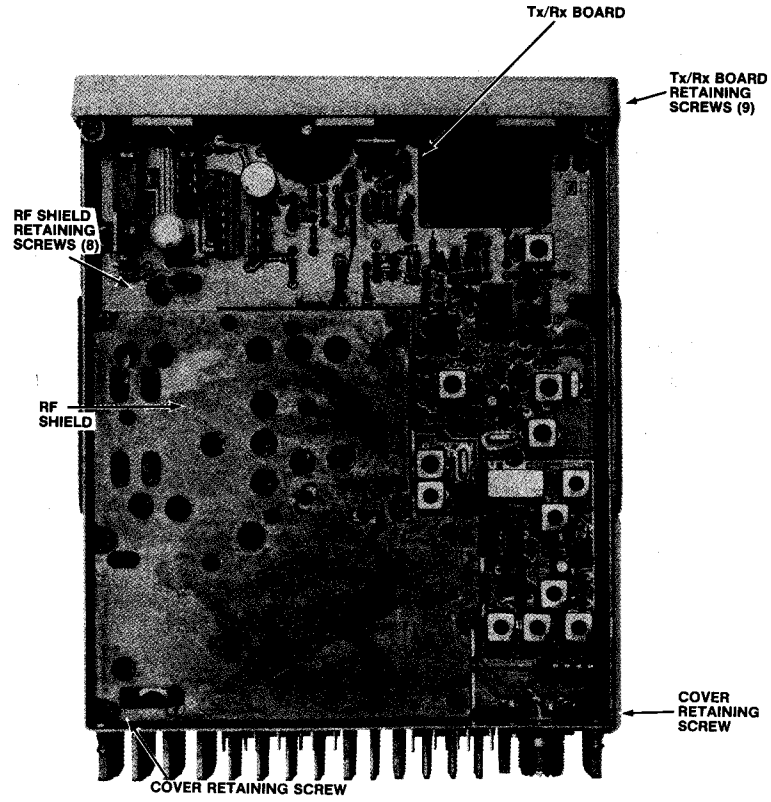

Figure 1 - Transmit/Receive Board Removal

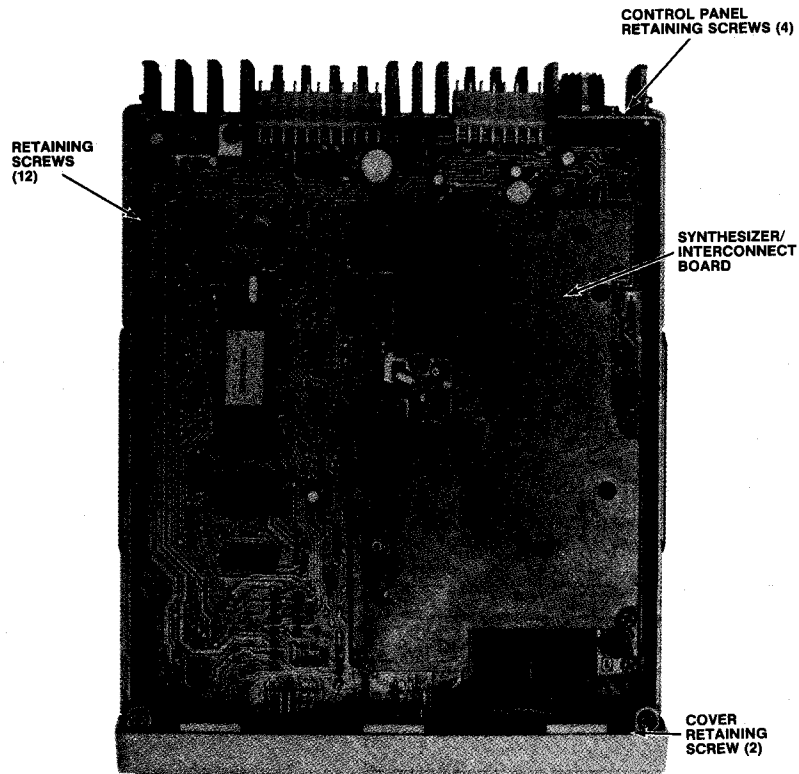

Figure 2 - Synthesizer/Interconnect Board Removal

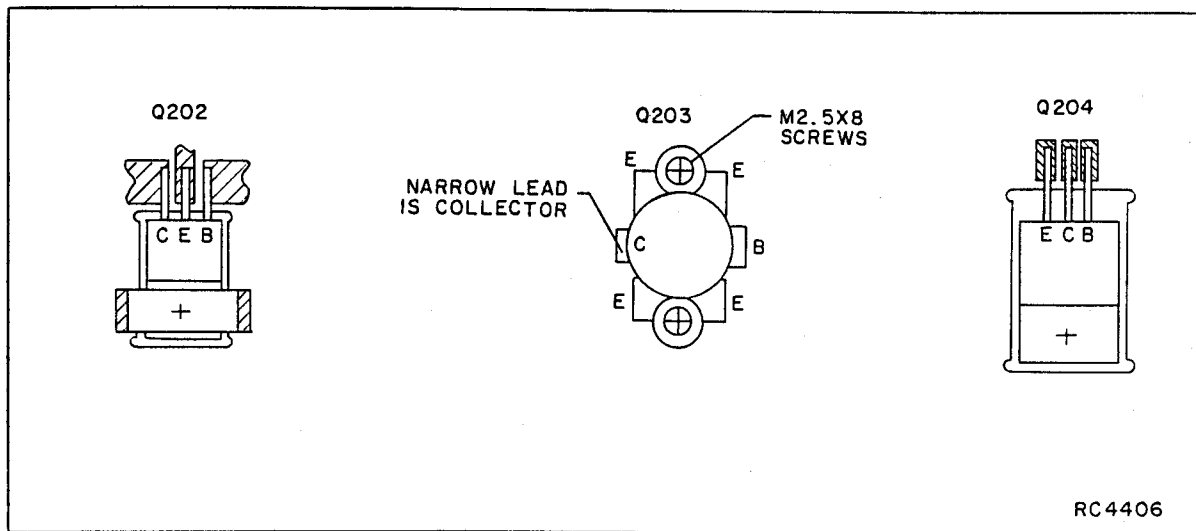

Figure 3 - Driver and PA Transistor Lead Identification

NOTE

The metalized end terminations of the parts may be touched with the soldering iron without causing damage.

TO REMOVE CHIP COMPONENTS

1. Grip the component with tweezers or needle nose pliers.
2. Alternately heat each end of the chip in rapid succession until solder flows, and then remove and discard the chip.
3. Remove excess solder with a vacuum solder extractor or Solder-wick®.
4. Carefully remove the epoxy adhesive and excess flux to prevent damage to the printed board.

TO REPLACE CHIP COMPONENTS

1. Using as little solder as possible, "tin" one end of the component and one of the pads on the printed wiring board.
2. Place the "tinned" end of the component on the "tinned" pad on the board and simultaneously touch the component and the pad with a well "tinned" soldering iron while pressing the component down on the board.

3. Place the "tinned" soldering iron on the other end of the component and the pad simultaneously. Apply solder to the top of the end of the component until the solder starts to flow. Use as little solder as possible while getting a good joint.

4. After the component has cooled, remove all flux from the component and printed wiring board area with alcohol.

REMOVING IC'S

Removing IC's (and all other soldered-in components) can be easily accomplished by using a vacuum desoldering tool. To remove an IC, heat each lead separately on the solder side and remove the old solder with the desoldering tool.

TEST AND TROUBLESHOOTING PROCEDURES

Maintenance of radio is facilitated by using the Troubleshooting Procedures and servicing techniques unique to this radio. The Troubleshooting Procedures are designed to lead you rapidly to the defective component or circuit. Typical voltage readings are provided on the Schematic Diagram for your reference when troubleshooting.

Troubleshooting Procedures are provided for most major problems that might arise in the Transmitter/Receiver section

of the radio. A microcomputer diagnostics section is provided for troubleshooting the microcomputer circuits.

— SERVICE HINT —

If the radio is inoperative with a defective microcomputer, it may be wise to run through the diagnostic routines first when troubleshooting the radio.

SERVICING TECHNIQUES

The high density plug-in design of the modular radio lends itself well to rapid isolation of malfunctions in the voltage and signal paths. A majority of the signals and voltages pass through the connectors on the synthesizer/interconnect board.

To isolate a signal or voltage path to determine loading effects, locate short circuits, etc. carefully insert an insulator (plastic wand, toothpick) between the appropriate pins of the related molex connector to create an open circuit. Signals paths that may be isolated include: Volume SQ HI, filtered volume squelch HI, PTT, Rx MUTE, and SPKR HI.

SERVICE TIPS

When servicing the microcomputer/synthesizer circuitry it is sometimes desirable to force the microcomputer into specific operating modes. Following are some tips that allow you to initiate these modes.

Microcomputer

- To force the microcomputer to continually try to reload the synthesizer. Ground the lock detect line to the microcomputer at U801-6. This mode will enable you to check the serial data, clock, advance change pulse and enable signals to the synthesizer.
- To stop the microcomputer from running, disable the watchdog timer by shorting the collector and emitter of Q803 and grounding the single step line at U801-5.

When servicing the Channel Guard circuitry, remember that the MONITOR switch bypasses the Channel Guard filter. Therefore, if the MONITOR pushbutton is pressed while receiving a signal that has a Channel Guard tone or digital code present, the tone/code will be audible in the speaker.

Microphonics

Synthesized radios tend to be sensitive to shock and vibration, creating microphonics. The construction of the Phoenix-S, SX radios with its die cast frame, two cast shields, and multiple board mounting screws, provide a high degree of immunity. Note, when removing the front cap, either printed circuit board or shields, the location and position of all mounting hardware including rubber padding and bracket (if included).

When servicing the radio be sure that no solder build-up has occurred on the chassis or shield, or seating plane. The seating plane is formed by the webbing and bases that are cast in the chassis.

To assure a high degree of resistance to microphonics and trouble free operation be sure to replace exactly, all hardware removed. Be sure that all mounting screws are properly torqued and shields in place. Refer to Mechanical Layout Diagram.

— NOTE —

Loose or rubbing parts, especially in the VCO and front cap area are particularly sensitive and can cause microphonics. Again be certain all hardware is properly installed and torqued.

TEST POINTS

Three transmitter test points are provided to monitor operation of the radio. Two of these (TP101 and TP501) are located on the transmit/receiver board: TP101 is located on the synthesizer/interconnect board. L104 on the synthesizer/interconnect board is tuned for maximum voltage on TP101 (not to exceed 7.1 volts) at the highest transmit channel frequency. TP101 on the transmitter/receiver board monitors the TX VCO injection to the exciter and is typically +0.2 volts. TP501 monitors the receiver 2nd IF, 455 kHz. Refer to Receiver Alignment for use of this test point for alignment purposes.

MICROCOMPUTER DIAGNOSTICS

The microcomputer contains self diagnostic programming to facilitate troubleshooting. Since the radio cannot function with a defective microcomputer, these routines should be performed first when troubleshooting the radio. The self diagnostic tests include internal and

input/output tests to verify the proper operation of the processor. The internal tests include a ROM test to make sure the proper program is in the chip and a RAM test to check the transfer of data to and from all memory locations. The input/output tests include a test which grounds one pin at a time on Port 1 and the data bus and a test which mirrors the inputs PTT, A/B switch, channel select switch, and Channel Guard disable onto the data bus. These tests verify operation of the ports and data bus, in addition to checking the input/output instructions of the microcomputer.

TEST EQUIPMENT REQUIRED

- 13.8 VDC supply, 500 mA (unless being tested in radio)
- DC Voltmeter (Data Tech 30L or equivalent)
- Oscilloscope (Tektronix 404 or equivalent)

TEST PROCEDURE

NOTE

This procedure assumes the synthesizer/interconnect board is being tested in the radio. Alternate procedures for bench test are shown in parenthesis ().

1. Connect oscilloscopes to J903-7 and ground.
2. Enter the self diagnostic mode as follows:
 - Key microphone while on hook. (Ground J911-2).
 - Press channel select button. (Ground J911-7).
 - Turn radio on. (Apply 13.8 VDC to J912-1).

CAUTION



The CMOS Integrated Circuit devices used in this equipment can be destroyed by static discharges. Before handling one of these devices, the serviceman should discharge himself by touching the case of a bench test instrument that has a 3-prong power cord connected to an outlet with a known good earth ground. When soldering or desoldering a CMOS device, the soldering iron should also have a 3-prong power cord connected to an outlet with a known good earth ground. A battery-operated soldering iron may be used in place of the regular soldering iron.

CAUTION

Before bench testing the radio, be sure of the output voltage characteristics of your bench power supply.

To protect the transmitter power output transistors from possible instant destruction, the following input voltages must not be exceeded:

Transmitter unkeyed: 20 Volts

Transmitter keyed (50 ohm resistive load): 18 Volts

Transmitter keyed (no load or non-resistive load): 15.5 Volts

These voltages are specified at the normal vehicle battery terminals of the radio and take the voltage drop of standard cables into account. The voltage limits shown for a non-optimum load is for "worst case" conditions. For antenna mismatches likely to be encountered in practice, the actual limit will approach the 18 Volt figure.

Routine transmitter tests should be performed at EIA Standard Test Voltages (13.6 VDC for loads of 6 to 16 amperes: Input voltages must not exceed the limits shown, even for transient peaks of short duration.

Many commonly used bench power supplies cannot meet these requirements for load regulation and transient voltage suppression. Bench supplies which employ "brute force" regulation and filtering may be usable when operated in parallel with a 12 Volt automotive storage battery.

ROM AND RAM TESTS

Once power is supplied to the board the microcomputer will jump to the self diagnostic test and immediately begin execution of the ROM and RAM tests. Upon completion of the ROM and RAM test (less than a second) the display, data bus, or alert tone will indicate if the test has passed.

	D3	D2	DB	D0	DISPLAY	ALERT TONE
ROM TEST FAILED	0	0	0	0	0	NONE
ROM TEST PASSED RAM TEST FAILED	0	0	0	1	1	NONE
ROM TEST PASSED RAM TEST PASSED	0	0	1	0	2	1 kHz

If there is no display board then the alert tone will indicate status. If the tests have passed a 1 kHz tone will be heard on the speaker and displayed on the oscilloscope. If no alert tone is present then either the ROM or RAM test has failed. If there is no display present, the data bus can be used. Replace the microcomputer.

If any of the above tests fail, the microprocessor function is not working properly. Do not replace microprocessor before checking all other possibilities. (The microprocessor is very reliable). Check associated circuitry for shorted printed wire runs and defective components.

Input/Output Port Test

If the ROM and RAM tests run successfully, release the PTT and channel select switches. (Remove ground from J911-2 and 7). The display will still indicate 02 but the alert tone should no longer be displayed on the scope or heard on the speaker.

The I/O test grounds 1 pin at a time on Port 1 and the data bus and is stepped through the test sequence by operating the PTT switch (momentarily grounding J911-2.) Port 1 and the data bus can be monitored using a voltmeter. Port 1 consists of pins 27-34 on microcomputer U801. The data bus includes pins 12-19 on U801. Refer to Schematic Diagram for data bus and port identification for U801. For example: P17 = port 1 bit 7.

1. Momentarily press and release the PTT switch (S1). The

display will go blank and port 1 (U801-27 thru 34) and data bus lines will all go high.

2. Repeat Step 1. The display (if present) will remain blank and P1-7 (U801-34) and D7 (U801-19) will go low. All other outputs should be high (greater than VDC 0.5).
3. Repeat Step 1. The display (if present) will remain blank and P1-6 (U801-33) and D6 (U801-18) will go low. All other outputs should be high.
4. Repeat Step 1. The display (if present) will remain blank and P1-5 (U801-32) and D5 (U801-17) will go low. All other outputs should be high.
5. Repeat Step 1. The display (if present) will remain blank and P1-4 (U801-31) and D4 (U801-16) will go low. All other outputs should be high.
6. Repeat Step 1. The display (if present) will remain blank and P1-3 (U801-30) and D3 (U801-15) will indicate 7. All other outputs should be high.
7. Repeat Step 1. The display (if present) will go blank and P1-2 (U801-29) and D2 (U801-14) will go low. All other outputs should be high.
8. Repeat Step 1. The display (if present) will remain blank and (U801-28) D1 (U801-13) will go low. All other outputs should be high. Note P1-1 remains high because this output switches the radio into the transmit mode when grounded. Thus this output is bypassed so that the radio will never go into the transmit mode during self test.
9. Repeat Step 1. The display (if present) will remain blank and P1-0 (U801-27) and D0 (U801-12) will go low. All other outputs should be high.
10. Repeat Step 1. The display (if present) will indicate zero and port 1 outputs (U801-27-34) will all be set high.

NOTE

At this point the program advances to mirror the outputs PTT, channel select, Channel Guard disable, Mode A/B switch onto the data bus D7, D5, D4, and D6, respectively. The lower nibble of the data bus will remain low so that the display (if present) will indicate zero.

11. Press the PTT switch (Ground J911-2) D7 (U801-19) should go low.
12. Release the PTT switch (Unground J911-2) D7 (U801-19) should go high.
13. Press Mode A/B switch (if present) (Ground U801-37). D6 (U801-18) should go low.
14. Release Mode A/B switch (if present) (Unground U801-37). D6 (U801-18) should go high.
15. Press channel select switch (Ground J911-7). D5 (U801-17) should go low.
16. Release channel select switch (Unground J911-7). D5 (U801-17) should go high.
17. Ground CG Disable J910-9. D4 (U801-16) should go low.
18. Remove ground from J910-9. D4 (U801-16) should go high.

NOTE

If any of the above tests fail, the microprocessor function is not working properly. Do not replace microprocessor before checking all other possibilities. (The microprocessor is very reliable). Check associated circuitry for shorted printed wire runs and defective components.

To exit the Diagnostic routine turn the radio off and then back on.



GE Mobile Communications

General Electric Company
Lynchburg, Virginia 24502

EXCITER VOLTAGE READINGS

Voltage Readings are typical readings made with the Transmitter keyed, and measured with a 20,000 ohms-per-volt VOM. An RF choke (10 microhenrys) is used in series with the hot meter lead to avoid detuning RF circuits.

TRANSISTOR	TRANSMITTER KEYED	TRANSMITTER UNKEYED
Q204-E -B -C	13.0 V 12.0 V 6-12 V	13.6 V 13.6 V 0 V
Q202-E -B -C	0 V 0 V 13.0 V	0 V 0 V 13.6 V
Q203-E -B -C	0 V 0 V 13.0 V	0 V 0 V 13.6 V
Q101-E -B -C	0.2 V 0.6 V 7.0 V	0.15 V 0.6 V 8.5 V
Q102-E -B -C	0 V 0 V 4.5 V	0 V 0.6 V 0 V
Q103-E -B -C	0 V 0 V 6.5 V	0 V -0.3 V 8.0 V
Q104-E -B -C	0 V 0 V 6-12 V	0 V 0 V 0 V
Q105-E -B -C	2.5-4 V 3-5 V 12 V	0 V 0 V 13.6 V
D201-A -C	1.4 V 0.7 V	0 V 0 V
D202-A -C	0.7 V 0 V	0 V 0 V

SYMPTOM	PROCEDURE
No 13.8 V Supply	Check power connections and continuity of supply leads. Check ON/OFF switch. Check radio for shorts. Check fuse in power line.
Low 13.8 V Supply	Check for low or uncharged battery possibly with bad cell in vehicle. Check radio for shorts or high resistance at A+ paths.
No 8.5 V Regulated Supply	Check 13.8 V supply at pin 1 of regulator U602. If 8.5 V is low, check for short on output of U602. Note that most of the receiver circuits can be isolated by lifting U601.
No Audio Output	<p>1. <u>Receiver may be squelched</u></p> <ul style="list-style-type: none"> • Rotate R607 (SQ. Pot.) fully counterclockwise to unsquelch the receiver. • Measure DC voltage on pin 2 of U601 (audio amp.). If this voltage is greater than .8 volts, the audio is being squelched. Check Q603 and Rx Mute voltage at P912-4. This input voltage should be approximately 5 volts to unsquelch the audio. Note operation of S602 (Monitor switch) opens the input to Q603 which should always result in Q603 being biased off; thereby insuring that U601 is unsquelched. <p>2. <u>No audio input to U601</u></p> <ul style="list-style-type: none"> • Check for audio at P902-7 (Filtered Volume/SQ. High). • Check for audio at P902-3 (VOL./SQ. Hi). <p>If audio is present at either of these points but does not reach pin 1 of U601 (audio amp.), check for loss of signal in Channel Guard reject filter on synthesizer/interconnect board or through monitor switch (S602) and volume pot (R617). Check for open in VOL.CONT./DE-EMPHASIS CIRCUITS. Check DC voltages around U601 according to schematic. Check speaker connections.</p>
Low Audio	<p>Check supply voltage at pin 5 of U602. Verify correct audio levels at:</p> <p>P903-3 325 mV +100 -50 mV P903-7 270 mV +100 -50 mV U602 pin 1 37.5 +10 mV at maximum volume</p> <p>(NOTE: 1 kHz modulation at 3 kHz deviation)</p> <p>If audio levels are low, tune L514 for maximum level.</p> <p>If low level at pin 1 of U601, check for defective components, shorts or opens, between U601 and volume control.</p>
Distorted Audio Output	Apply a strong RF signal with standard test modulation and measure audio distortion into an 4 ohm dummy load. Distortion should be less than 5% at 3.46 VRMS audio output. Check for 13.8 V at pin 5 of U601. Check DC voltages around U601 per schematic. Tune L514 slightly to note any improvement. Tune L503, and L512 slightly and note any improvement. Check frequency of 2nd oscillator at pin 2 of U501 with High Impedance Counter. It should be 45.455 MHz \pm 200 Hz. If no improvement is noted, check for defective IC U501, or defective filters Z501, Z502 and Z503. Check bias voltage for Q511.

SYMPTOM	PROCEDURE
No or Incorrect Detector Output	Check audio level at base of Q601. Should be 300 mV +100 -50 mV under standard test conditions. Check DC bias levels around U501 under high RF input level (1 mV or more) per schematic. Tune L514 and note improvement, if any. Check for shorts or opens around L514 circuitry. Check limiter output at pin 7 of U501 with scope; should be square wave at 455 kHz at .4 V P-P.
No 2nd Oscillator Activity	Substitute a known good crystal for Y501. Check voltages on U501 pins 1 and 2. Tune L513 and note improvement, if any.
Radio Permanently Squelched	Verify that U501 is properly biased, and that quad coil L514 is correctly adjusted. With no RF input, the voltage at pin 12 of U501 should vary as R607 is varied (see schematic). Check for switching action at pins 13 & 14 as R607 is varied. If no changes in voltages per schematic, U501 may be defective. With pin 14 in UNSQ. condition, check voltage at emitter of Q602; should be 4.5-5.2 V. If correct, operate monitor switch. If radio unsquelches, check for Channel Guard presence or microcomputer malfunction. If monitor switch does not open radio, check bias levels around Q603 per schematic. Also check bias levels around U601. Check speaker connections and jumpers on synthesizer/interconnect board.
Radio Won't Squelch	Verify that U501 is properly biased and that quad coil L514 is correctly adjusted. With no RF input, rotate R607 and note bias voltages on U501 per schematic. Check for high frequency (6 kHz and above) noise at pin 11 of U501. D601 should negatively rectify this noise. Rotate R607 and note voltage at the emitter of Q602. It should change with pin 14 changes, in same polarity. In unsquelched condition emitter voltage should be no higher than 5.5 V. If so, Q602, R625, R630, or R631 is defective. If U501/Q602 function is correct, check for microcomputer malfunction. Also check Q603 function per schematic. Ground P903-4 and radio should squelch. If not, Q603 circuitry may be faulty. If Q602/P912-3 levels are switching as R607 is rotated and P903-4 levels do not switch, refer to microcomputer troubleshooting section.
Poor or No Sensitivity	Verify that proper injection power is present and at the correct frequency, (f. +45 MHz). This can be done by a high impedance probe from the junction of C308 and C309 to ground. The power seen should be approximately 10 dBm. If OK, then use a 50 ohm probe with a signal generator to inject signal into various portions of the radio to isolate the bad section. Set the generator with standard modulation to the level and frequency indicated on the large service schematic and probe those points starting with IC (U501) and moving forward to the antenna jack. In some cases parts must be adjusted for best sensitivity while probing. This is indicated on the schematic. Once the faulty stage is isolated, measure bias voltages. Check PIN diodes in Transmit/Receive switching section of transmitter.
No or Low Injection Power	Monitor the L.O. input with a high impedance probe at J351, synthesizer input. This level should be approximately +10 dBm at the injection frequency. Check the bias levels on Q301 with a DC volt meter.
Frequency Won't Adjust Properly	Check compensator voltage at P3-2 and at varicap (D2, D6, D7 or D9). Check anode voltage of varicap.

SYMPTOM	PROCEDURE
No Transmit 8.5 V	Check the switching transistor Q604.
Radio Won't go into Transmit Mode	Check Q604. If OK, check pin 4 P901. There should be no voltage between pin 4 and ground when PTT is depressed.
Low or No Transmit Power	Check the voltage at TP101. When PTT is depressed, the DC voltage should decrease by about 0.1 volt. If not, then check J151. Make sure the feed thru pin from Interconnect board is making good contact with J151. If everything is OK, then check Q204 and Q105.
Oscillator Frequency Will Not Adjust Properly	Check circuitry associated with reference oscillator Q101. Verify part values and check crystal Y101 and L101. Oscillator frequency should adjust to 13.2 MHz.
No Transmitter Deviation	Check audio processor U301 and its associated circuitry. If OK, check Q301 and audio levels at output of pots R320 and R316. If OK, check C122 and C101.

In all PHOENIX-SX model radios, in which the EE PROM is not custom programmed, (Option A0) the EE PROM is programmed with the personality shown in Table I below. Note that personalities for VHF and UHF frequency bands wideband and narrowband radio combinations with tone and digital Channel Guard and carrier control timer are pre-programmed. When selecting a test channel be sure the channel/mode selected is compatible with the radio being serviced. Refer to the combination number on the radio and the combination nomenclature chart in this manual to verify operating frequency range.

TABLE 1 - TEST PROM PROGRAMMING

136-153 MHz					150-174 MHz				
Channel Mode	Frequency (MHz)		Channel Guard	CCT	Frequency (MHz)		Channel Guard	CCT	
	Transmit	Receive			Transmit	Receive			
1A,B	144.025	144.075	71.9	---	162.250	162.300	71.9	---	
1A,B	136.030	136.090	023	---	150.030	150.090	023	---	
1A,B	144.025	144.075	023	30 sec.	162.250	162.300	023	30 sec.	
1A,B	152.970	152.920	023	---	173.975	173.925	023	---	
1A,B	152.970	152.920	---	---	173.975	173.925	---	---	

TRANSMITTER ALIGNMENT

Since the exciter and transmitter are broadbanded and the VCO Tx injection frequency is the transmit frequency, no tuning is required. Some adjustments, however, are required to optimize operation. They include: the VCO control voltage, deviation, and RF output power.

TEST EQUIPMENT

1. Audio Oscillator
2. Deviation Monitor
3. AC Voltmeter
4. Wattmeter, 50 ohm, 50 Watts
5. Directional coupler
6. Voltmeter (20,000 ohms per volt)
7. 13.8 V Regulated Power Supply
8. 50-ohm Load

PRELIMINARY CHECKS AND ADJUSTMENTS

NOTE

Refer to photographs to locate CONTROLS, and TEST POINTS.

All adjustments are made with transmitter keyed. Unkey the transmitter between steps to avoid overheating.

1. Check P903-2 for 8.5 volts +0.15 volt before any alignment is attempted.
2. Set up test equipment as shown in Figure 4.

VCO CONTROL VOLTAGE

1. Select channel with highest transmit VCO frequency.
2. Monitor TP101 on synthesizer/interconnect board and adjust L104 on the synthesizer/interconnect board for maximum voltage. (Not to exceed +7.0 volts).

FREQUENCY ADJUSTMENT

1. Select a center frequency channel and adjust L101 on the synthesizer/interconnect board for channel frequency ±100 Hz.

MODULATION LEVEL ADJUSTMENT

CAUTION

DO NOT remove microphone from the optional hookswitch (if present), when making this adjustment. DAMAGE to equipment will result.

The CG encode circuit can be easily disabled to allow transmitter distortion and modulation checks (without removing covers) by temporarily connecting a jumper from J910-11 (A+) to J910-9 (CG DISABLE lead).

MOD ADJUST Control R320 has been adjusted to the proper setting before shipment and normally does not require readjustment. This setting permits approximately 75% modulation for the average-voice level.

MODULATION ADJUSTMENT WITH TONE CHANNEL GUARD

1. Connect the audio oscillator and the AC voltmeter across audio input terminals J911-4 (Hi) and J911-3 (Lo) on the synthesizer/interconnect board.
2. Adjust the audio oscillator for 1 volt RMS at 1000 Hz.
3. Connect RF Wattmeter to antenna jack
4. Set CG Mod adjust R724 and R316 fully counter clockwise.
5. Adjust R320 for 4.5 kHz deviation (3.75 kHz when channel Guard is used. Step through all transmit channels and adjust R320 such that no channel exceeds the deviation specified.
6. Set R724 for 0.75 kHz deviation.

MODULATION ADJUSTMENT WITH DIGITAL CHANNEL GUARD

1. Connect the audio oscillator and the AC voltmeter across audio input terminals J911-4 (Hi) and J911-3 (Lo) on the synthesizer/interconnect board.
2. Adjust the audio oscillator for 1 volt RMS at 1000 Hz.
3. Connect RF Wattmeter to antenna jack
4. Set CG Mod adjust R724 and R316 fully counter clockwise.
5. Adjust R320 for 4.5 kHz deviation (3.75 kHz when Channel Guard is used). Step through all transmit

channels and adjust R320 such that no channel exceeds the deviation specified.

6. Set the radio to center most frequency in the customer transmit board. Remove audio oscillator from J911 and using a 100 uf capacitor (+ end toward radio) couple a 300 Hz signal to J301 and adjust input level to obtain 1.5 kHz deviation. Keeping input level constant, adjust frequency for 10 Hz. Adjust R316 for 1.5 kHz deviation.
7. Remove signal from J301. Select frequency programmed for Digital Channel Guard. If available, select a center frequency.
8. Adjust R724 for 0.75 kHz deviation.

POWER ADJUSTMENT

1. Set transmitter to channel with highest RF frequency. Set R120 on transmit/receive board for 40 watts (35 minimum). Power output is typically adjustable from 30-40 watts.

When the radio is used as a control station, output power must be set to 25 watts maximum or so that total current drain does not exceed 6.0 amperes (a power supply limitation). Output power should be 20 watts minimum.

NOTE

Power output can be reduced to 20 watts by clipping out R125. Power output though will vary across the 136-153 or 150-174 MHz frequency band.

TRANSMIT/RECEIVER BOARD

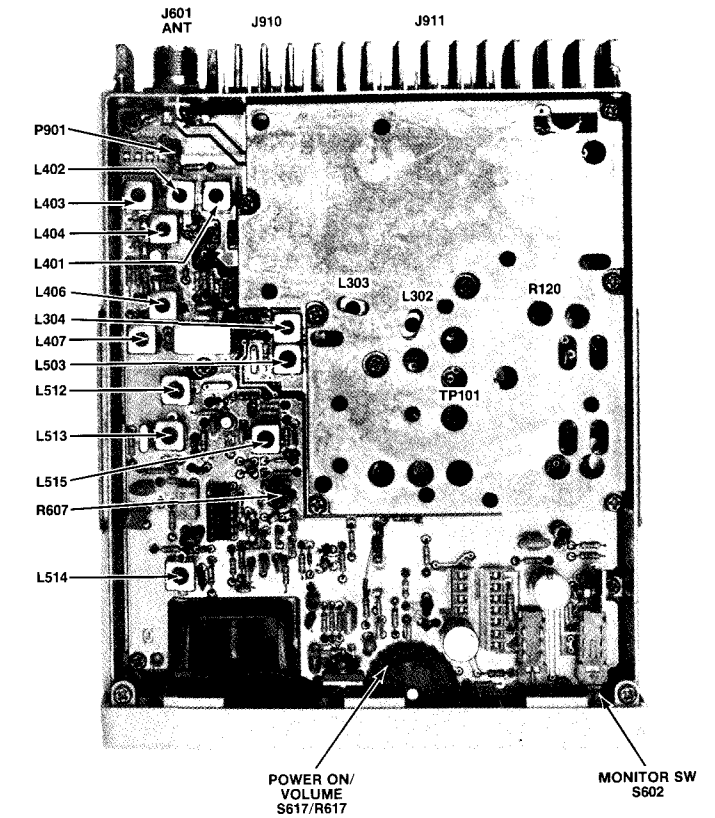

SYNTHESIZER/INTERCONNECT BOARD

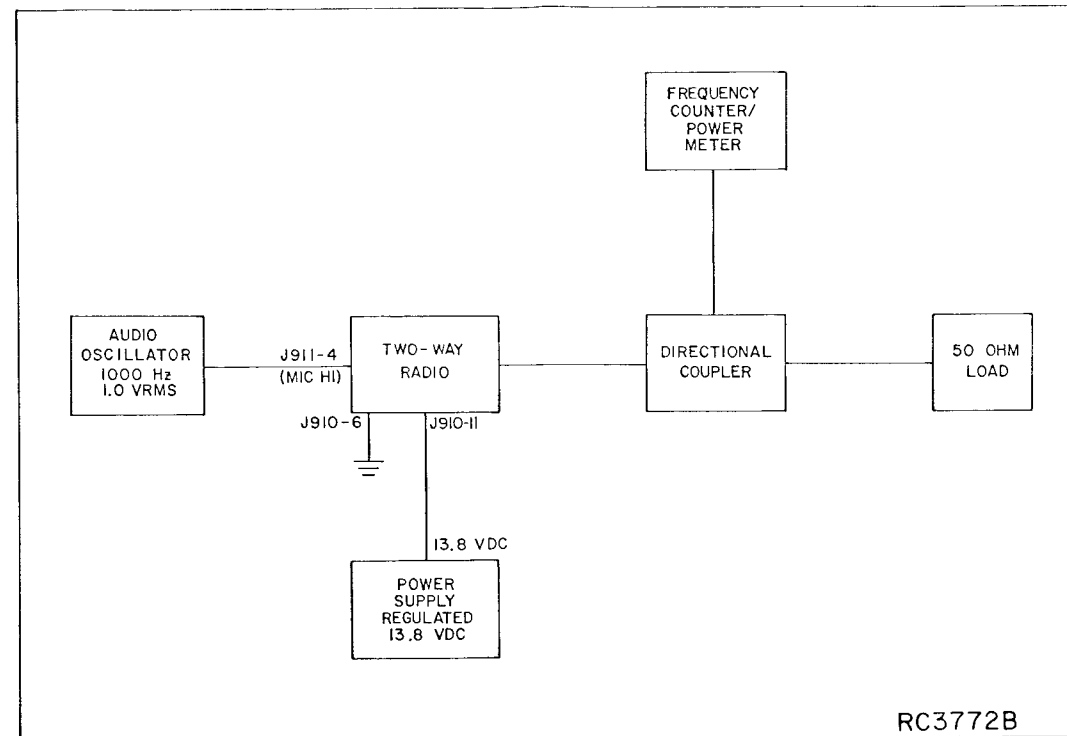
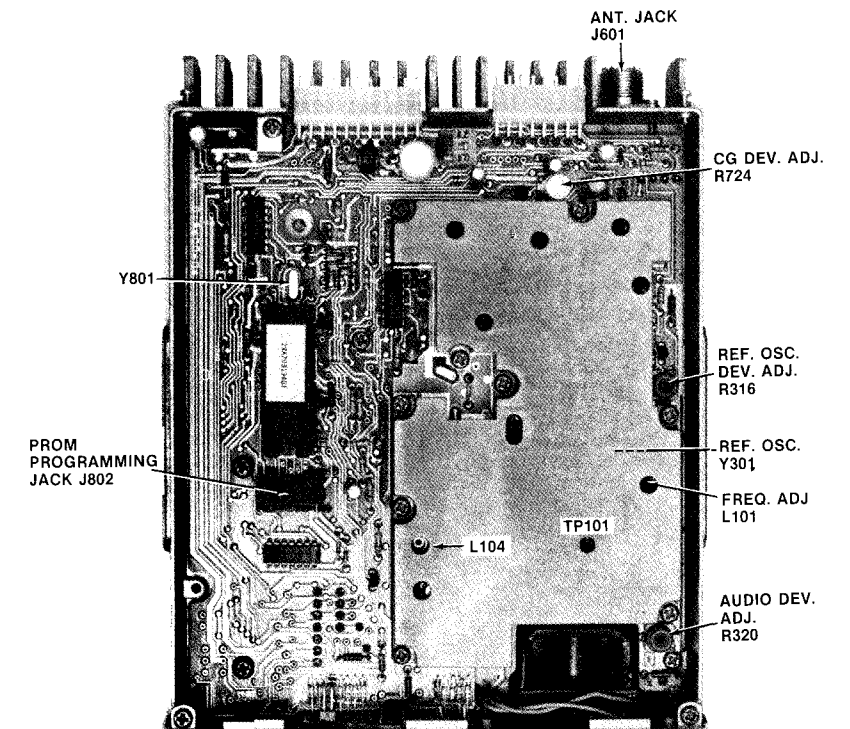

Figure 4 - Transmitter Alignment

RECEIVER ALIGNMENT

Test Equipment Required

1. RF Signal Generator (136-174 MHz)
2. AC Voltmeter
3. Power Supply, 13.8 V Regulated
4. Frequency Counter
5. 4 ohm, 5 watt resistor

PRELIMINARY CHECKS

1. Connect 13.8 VDC to J910-11(+) and J910-6(-).
2. Set MONITOR switch to "out" position
3. Turn radio on. Verify 8.5 VDC ± 0.15 VDC at P903-2.
4. Select desired channel.
5. Disable Channel Guard by removing microphone from the optional Channel Guard hookswitch (if present), or by connecting ground to J910-9.
6. Disconnect internal speaker from J904 on synthesizer/interconnect board. Terminate either J910-3 or J904 with a 4 ohm, 5 Watt resistor.

NOTE

Refer to photographs to locate CONTROLS, and TEST POINTS.

NOTE

The PHOENIX-SX wideband-synthesized radio has been sweep aligned at the factory to demanding specifications using a complex test procedure and test set up. Therefore, no detailed receiver alignment or readjustment is necessary nor recommended.

Should it become necessary to replace a tunable coil it is recommended that the core position in the removed coil be noted and that the core in the replacement coil be positioned to a like position. Following this procedure should return the radio to service with little or no compromise in bandwidth. Check radio specifications on all operating channels. If necessary retune replaced coil slightly to obtain required response.

Adjustment Procedures are provided for the receiver 2nd oscillator, Quadrature Detector, Audio Power, and Squelch.

2nd RECEIVER OSCILLATOR

1. Using a frequency counter monitor TP501. Set L513 for a frequency of 455 kHz ± 50 Hz.

QUADRATURE DETECTOR

1. Apply a 1000 Hz modulated tone to the carrier generator. Set deviation to 3 kHz. Set carrier level to -50 dBm. Monitor audio level at P903-3 using an AC voltmeter (1-volt scale). Peak L514.

AUDIO OUTPUT

1. Adjust VOLUME control R617 for a level of 3.46 VRMS on AC voltmeter. (3 watts) Use test set up as described above.

FIXED SQUELCH ADJUSTMENT

1. Disable Channel Guard, if present, (ground J910-9). Set squelch control R607 full CCW.
2. Connect a signal generator to antenna jack J601 and adjust for a nominal 8 dB SINAD signal.
3. Adjust squelch control R607 to maximum squelch. Receiver must be muted.
4. Adjust squelch control R607 slowly until receiver unmutes.
5. Check that the squelch opens at an input signal level corresponding to 8 dB SINAD (± 1 dB).
6. Remove ground from J910-9 or re-enable Channel Guard.

RECEIVER ALIGNMENT

TEST PROCEDURES

These Test Procedures are designed to help you to service a receiver that is operating---but not properly. The problems encountered could be low power, poor sensitivity, distortion, limiter not operating properly, and low gain. By following the sequence of test steps starting with Step 1, the defect can be quickly localized. Once the defective stage is pin-pointed, refer to the "Service Check" listed to correct the problem. Additional corrective measures are included in the Troubleshooting Procedure. Before starting with the Receiver Test Procedures, be sure the receiver is tuned and aligned to the proper operating frequency.

TEST EQUIPMENT REQUIRED

- Distortion Analyzer
- Signal Generator
- 6 dB attenuation pad, and 4.0 ohm, 5 Watt resistor

PRELIMINARY ADJUSTMENTS

NOTE

These procedures are written around the Heathkit Distortion Analyzer. If a Distortion Analyzer other than the Heath IM-12 is used, measure the sensitivity and modulation acceptance bandwidth in accordance with manufacturer's instructions.

1. Disable the squelch by adjusting squelch control R607.

NOTE

Be sure to reset the squelch control after completing the Test Procedures.♥

STEP 1

AUDIO POWER OUTPUT
AND DISTORTION

TEST PROCEDURE

Measure Audio Power Output as follows:

- A. Apply a 1000 microvolt, on-frequency test signal modulated by 1,000 hertz with ± 3.0 Hz deviation to antenna jack J601.
- B. With 3 Watt Speaker
Disconnect speaker J904.
Connect a 4.0 ohm, 5 Watt load resistor across J904-1 & 2.
Connect the Distortion Analyzer input across the resistor as shown.
- C. Adjust the VOLUME control for 3 Watt output 3.46 VRMS using the Distortion Analyzer as a voltmeter.
- D. Make distortion measurements according to manufacturer's instructions. Reading should be less than 5%. If the receiver sensitivity is to be measured, leave all controls and equipment as they are.

SERVICE CHECK

If the distortion is more than 5%, or maximum audio output is less than 3 Watts, make the following checks:

- E. Battery and regulator voltage---low voltage will cause distortion. (Refer to Receiver Schematic Diagram for voltages.)
- F. Audio Gain (Refer to Receiver Troubleshooting Procedure).
- G. FM Detector Alignment (Refer to Receiver Alignment).

STEP 2

USABLE SENSITIVITY
(12 DB SINAD)

If STEP 1 checks out properly, measure the receiver sensitivity as follows:

- A. Apply a 1000 microvolt, on-frequency signal modulated by 1000 Hz with 3.0 kHz deviation to J601.
- B. Place the RANGE switch on the Distortion Analyzer in the 200 to 2000 Hz distortion range position (1000 Hz filter in the circuit). Tune the filter for minimum reading or null on the lowest possible scale (100%, 30%, etc.)
- C. Place the RANGE switch to the SET LEVEL position (filter out of the circuit) and adjust the input LEVEL control for a +2 dB reading on a mid range (30%).
- D. Set signal generator output to 0.3 μ V. Switch the RANGE control from SET LEVEL to the distortion range. Readjust Distortion Analyzer SET LEVEL as required until a 12 dB difference (+2 dB to -10 dB) is obtained between the SET LEVEL and distortion range positions (filter out and filter in).
- E. The 12 dB difference (Signal plus Noise and Distortion to noise plus distortion ratio) is the "usable" sensitivity level. The sensitivity should be less than rated 12 dB SINAD specifications with an audio output of at least 1.5 Watts (0.56 Volts RMS across the 4.0 ohm receiver load using the Distortion Analyzer as a Voltmeter).
- F. Leave all controls as they are and all equipment connected if the Modulation Acceptance Bandwidth test is to be performed.

SERVICE CHECK

If the sensitivity level is more than rated 12 dB SINAD, check the alignment of the RF stages as directed in the Alignment Procedure.

STEP 3

MODULATION ACCEPTANCE
BANDWIDTH (IF BANDWIDTH)

If STEPS 1 and 2 check out properly, measure the bandwidth as follows:

- A. Set the Signal Generator output for twice the microvolt reading obtained in the 12 dB SINAD measurement.
- B. Set the RANGE control on the Distortion Analyzer in the SET LEVEL position (1000 Hz filter out of the circuit), and adjust the input LEVEL control for a +2 dB reading on the 30% range.
- C. While increasing the deviation of the Signal Generator, switch the RANGE control from SET LEVEL to distortion range until a 12 dB difference is obtained between the SET LEVEL and distortion range readings (from +2 dB to -10 dB).
- D. The deviation control reading for the 12 dB difference is the Modulation Acceptance Bandwidth of the receiver. It should be more than ± 6.5 kHz.

SERVICE CHECK

If the Modulation Acceptance Bandwidth test does not indicate the proper width, refer to the Receiver Troubleshooting Procedure.

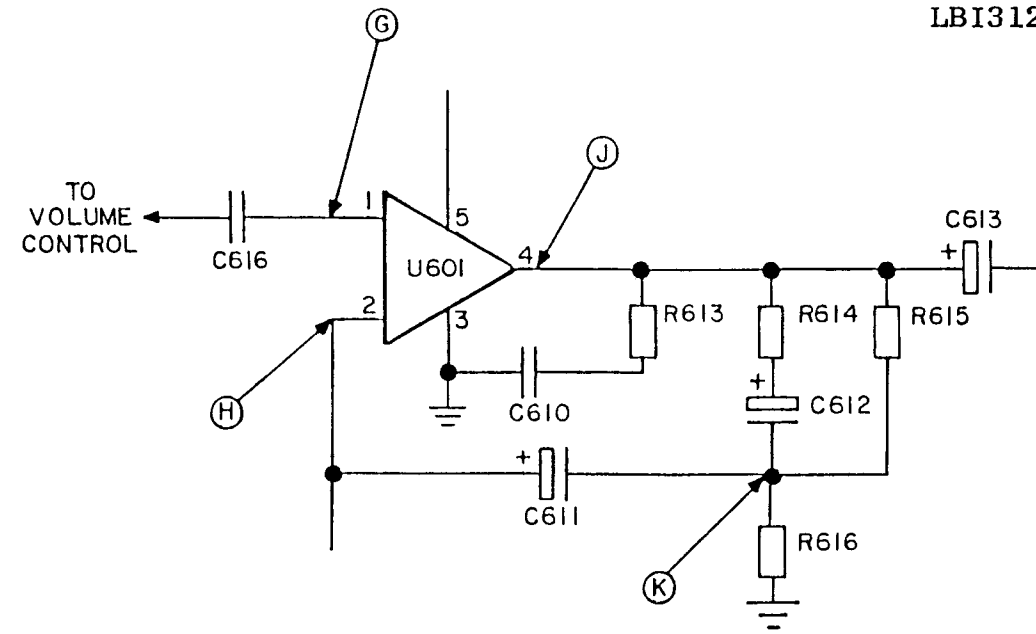

AUDIO CIRCUIT CHECKS

PRELIMINARY STEPS

1. Apply 1000 uv on frequency signal with 1000 Hz modulation and 3 kHz deviation to antenna jack J601.
2. Monitor pushbutton "IN".
3. Output set for 3-Watts (3.46 VRMS) into 4 ohm load.
4. Use 1 megohm probe.

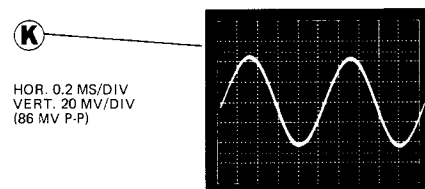
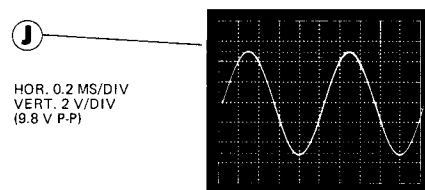
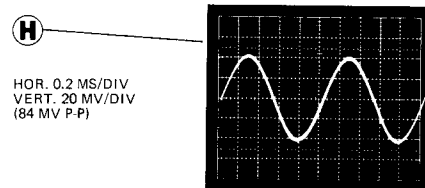
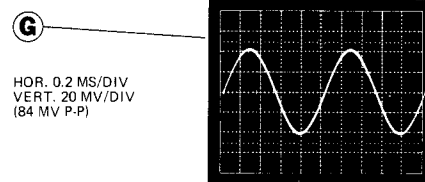

RECEIVER AUDIO CHECKS

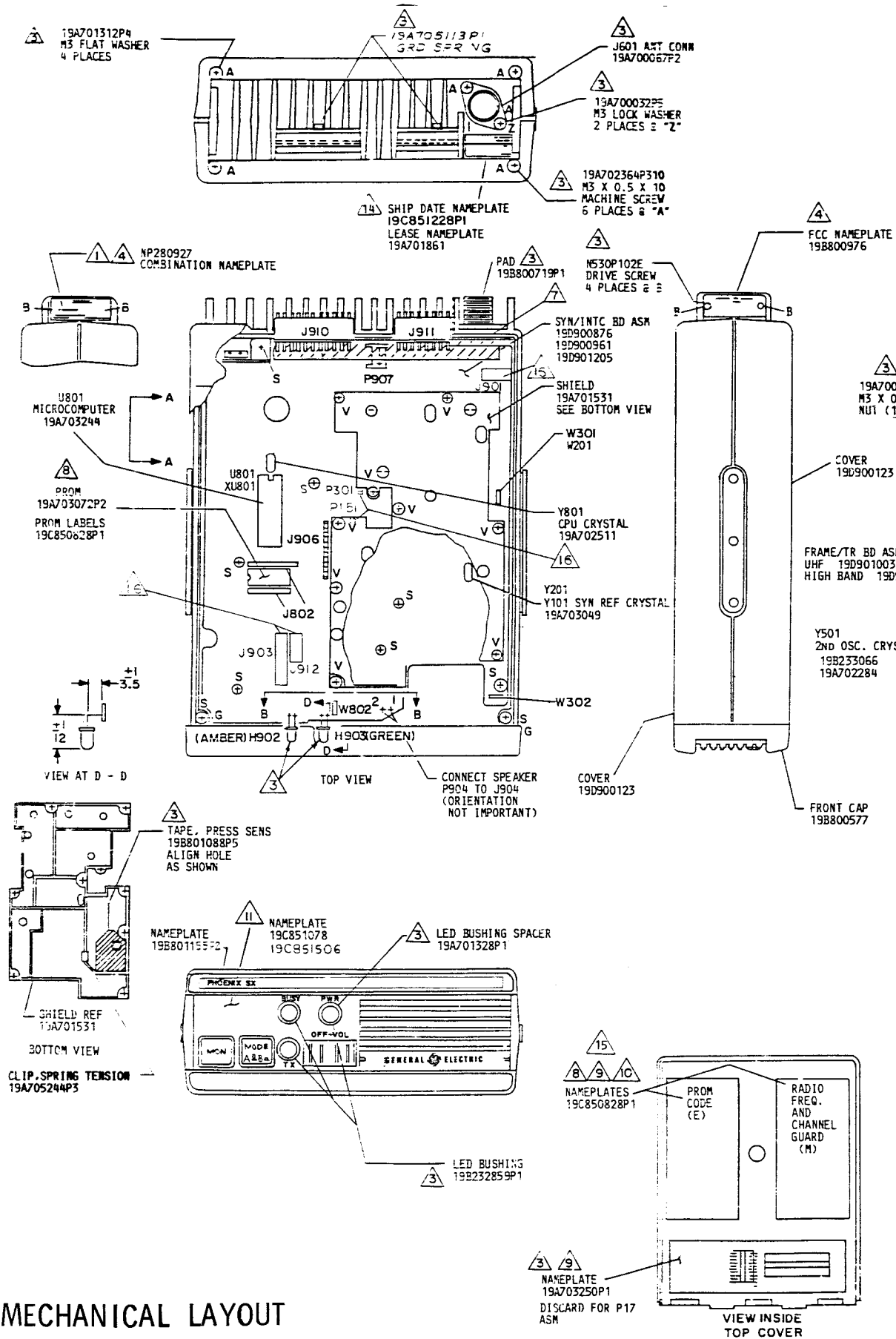

36 CPU ALTERNATE CRYSTAL
 REMOVE Y801 (19A702511G3) AND REPLACE WITH NEW Y801 SUPPLIED. RETURN 19A702511G3 TO STOCK.

i FOR NOTES SEE SHEET 1A

14 2.5 PPM (19D901205 SYN ONLY) FOR 2.5 PPM OPERATION REMOVE Y201 (19A703049G1, 13.2 MHz) AND REPLACE WITH CRYSTAL 19A703049G7.

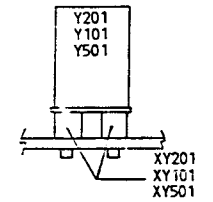

18 WHEN ALTERNATE SYNTHESIZER CRYSTAL (OPTION "F", VALUE "S") IS ORDERED INSTALL CRYSTAL (19A703049G5, 13.8 MHz) IN XY101 AND RETURN THE CRYSTAL (19A703049G1, 13.2 MHz) TO STOCK.
 WHEN ALTERNATE 2ND OSCILLATOR CRYSTAL (OPTION "F", VALUE "T") IS ORDERED, INSTALL CRYSTAL (19A702284G2 [H3], OR G4 [UHF]) IN XY501 AND RETURN THE CRYSTAL (19A702284G1 OR G3) TO STOCK.

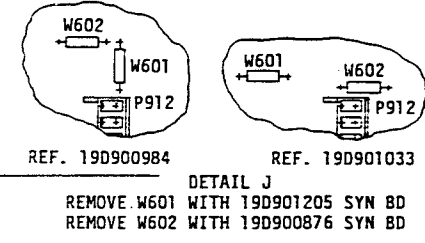

20 UHF MODIFICATION
 REMOVE THE FOLLOWING JUMPERS ON SYNTHESIZER BD DENOTED BY X:

JUMPER	19D900876	19D900961	19D901205
W201			X
W301	X	X	
W302	X	X	X
W802		X	

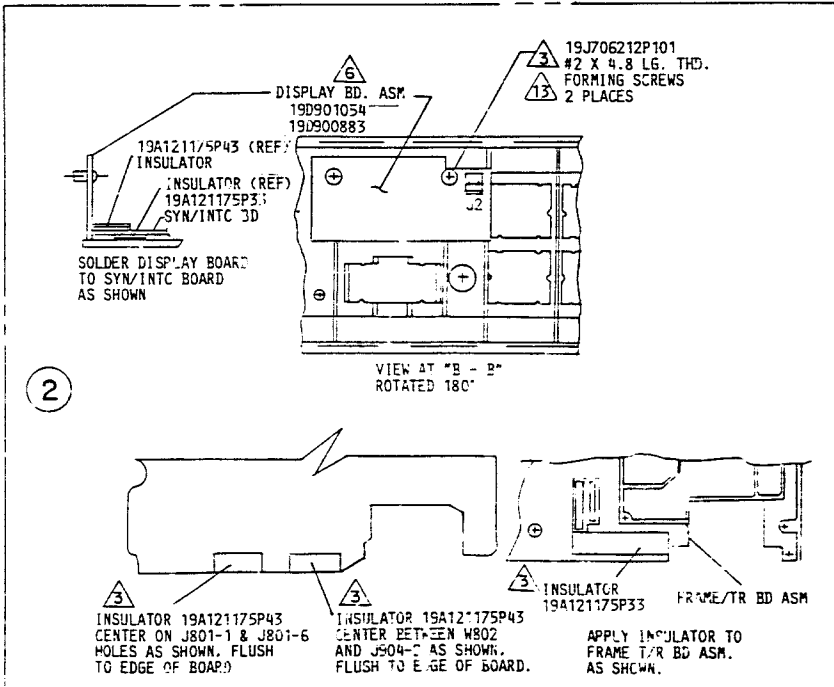
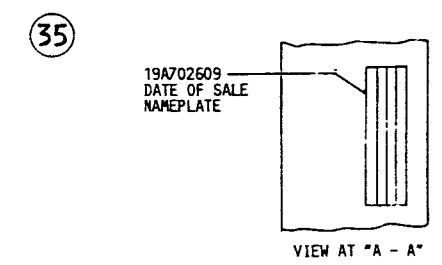

MECHANICAL LAYOUT

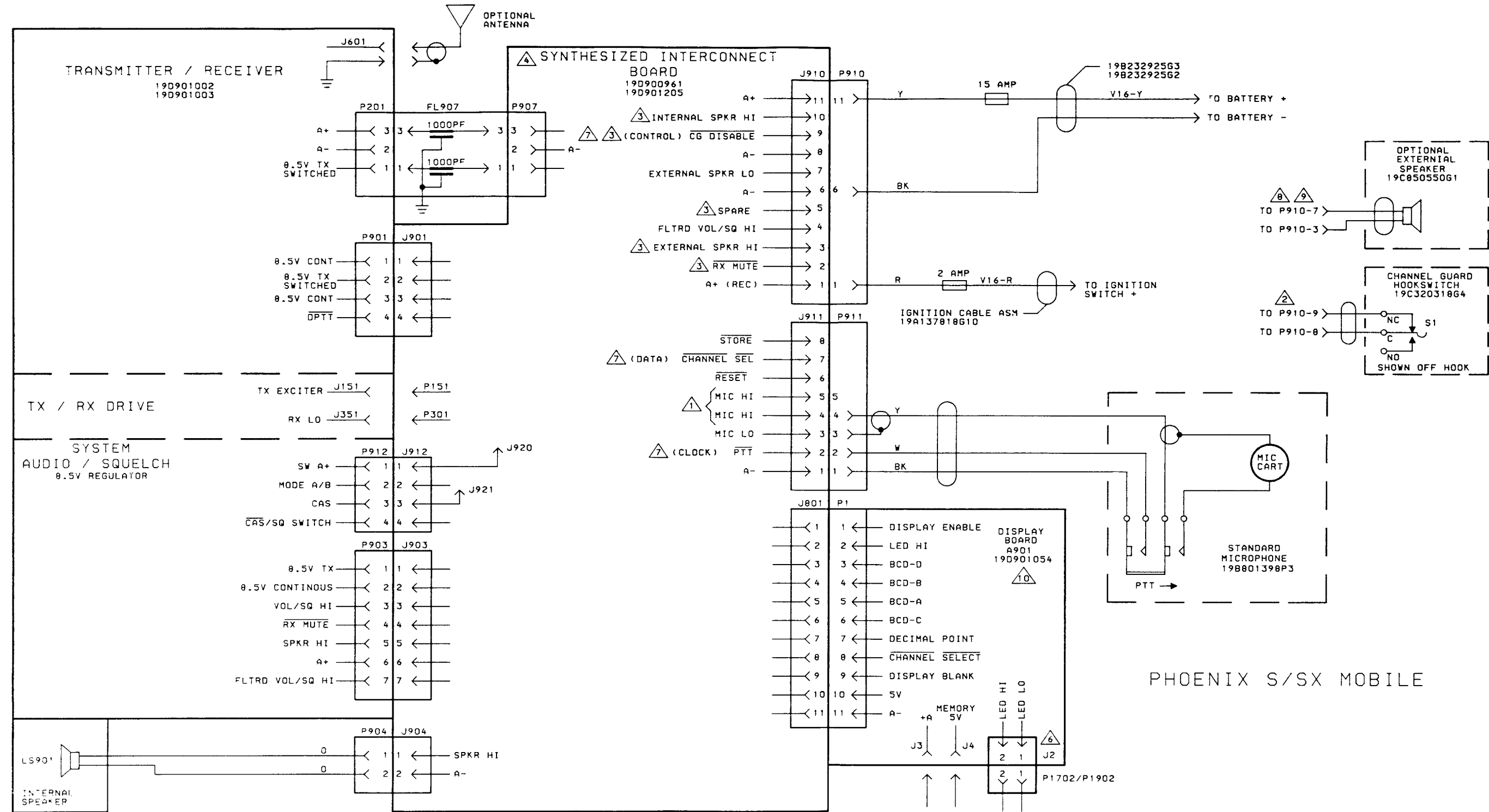

NOTES:

- ⚠ J911-5 USED IN PSX200.
- ⚠ FOR T99 DECODER OPTION, CONNECT TO P910-5 (MONITOR/RESET).
- ⚠ FUNCTIONS AT J910 ARE DIFFERENT FOR VARIOUS OPTIONS. REFER TO THE SYNTHESIZED INTERCONNECT WIRING DIAGRAM FOR THESE FUNCTIONS. FOR PHOENIX GE MARC V, J910-5 IS EXT ALARM FUNCTION.
- ⚠ SEE SHEET 2 FOR OPTION INTERFACE. SEE SHEET 3 FOR 16 FREQ/SCAN DISPLAY BOARD INTERFACE. SEE SHEET 4 FOR 16 FREQ/SCAN WITH MODE EXPANDER. SEE SHEET 5 FOR GE MARC V INTERNATIONAL OPTION INTERFACE.
- ⚠ WHEN THE UNIVERSAL TONE CABLE IS USED WITH PA OPTION, CONNECT THE WHITE-GREEN WIRE TO H6 AND THE ORANGE WIRE TO H11 ON THE SYNTHESIZED INTERCONNECT BOARD. SEE SHEET 2.
- ⚠ J2 USED WHEN T99, OR PUBLIC ADDRESS ARE USED. R911 MUST BE REMOVED ON THE INTERCONNECT BOARD AND R8 MUST BE REMOVED ON THE DISPLAY BOARD A901, REMOVE JUMPERS HL20 TO HL21, HL22 TO HL23 ON SCAN DISPLAY BD A902 & A903.
- ⚠ PIN DEFINITIONS SHOWN IN BRACKETS APPLY WHEN LOADING THE EEPROM.
- ⚠ EXTERNAL SPEAKER INTERFACE CABLE IS REQUIRED WHEN DTMF ENCODER OR 16 FREQ/SCAN OPTIONS ARE USED WITH PUBLIC ADDRESS OPTION. SEE SHEET 2.
- ⚠ J2 AND CONTACTS ARE PART OF EXTERNAL SPEAKER MOD KIT 19A703913G2. SEE SHEET 2.
- ⚠ DIFFERENT DISPLAY USED WITH GE MARC V INTERNATIONAL. SEE SHEET 5.

PHOENIX S/SX MOBILE

INTERCONNECTION DIAGRAMS
SYSTEMS INTERCONNECTION

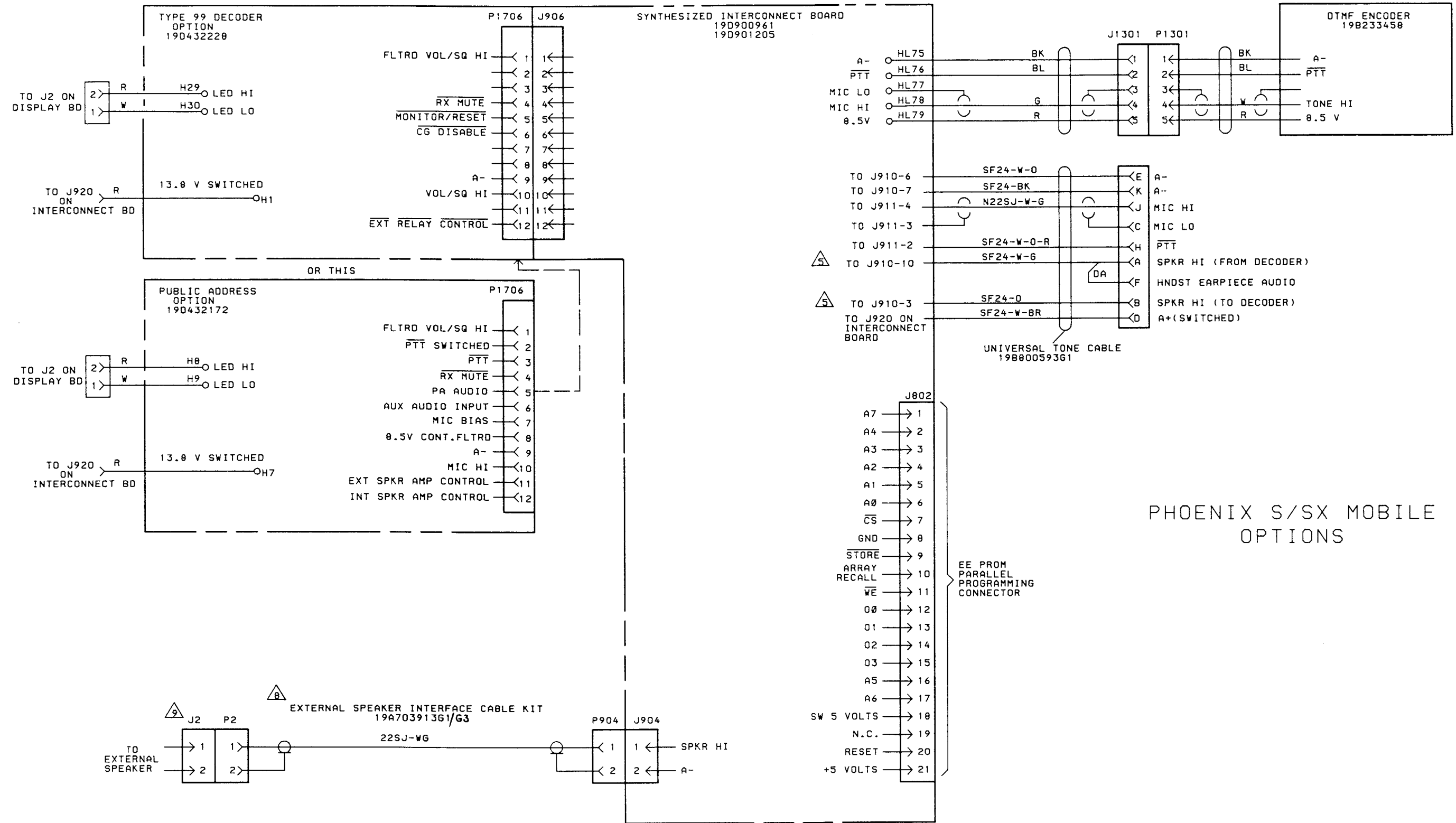

INTERCONNECTION DIAGRAM

OPTION INTERCONNECTION

(19D901058, Sh. 2, Rev. 5)

DESK MICROPHONE WITH OR WITHOUT TYPE 99 DECODER

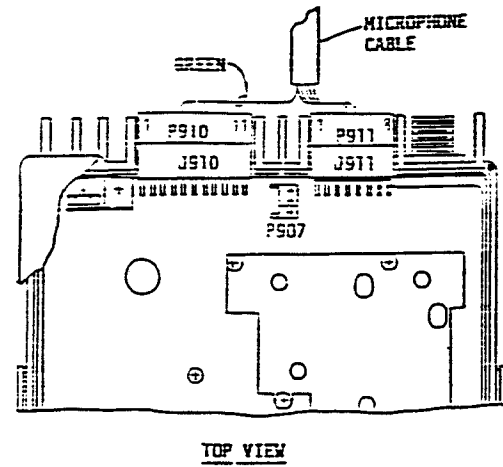

NOTES:

1. FOR USE WITHOUT TYPE 99 DECODER, MOVE GREEN WIRE FROM P911-5 TO P910-9
2. FOR USE WITH TYPE 99 DECODER, MOVE GREEN WIRE FROM P911-5 TO P910-5

HOOKSWITCH APPLICATION

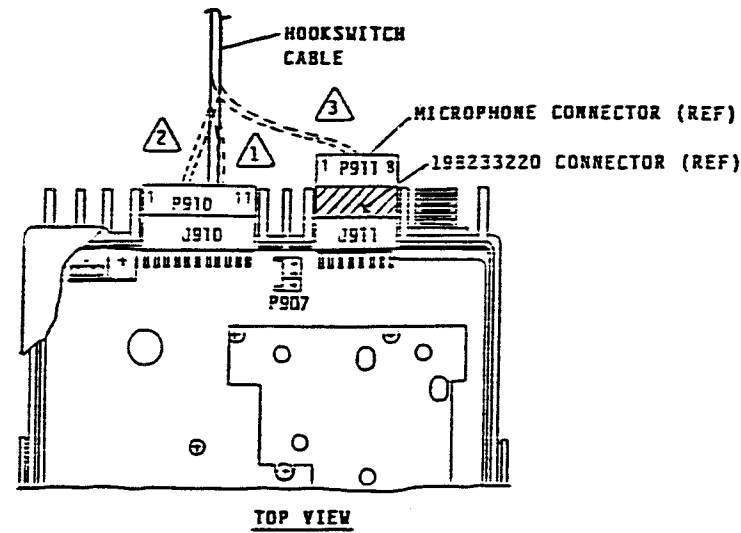

NOTES:

1. CONNECT HOOKSWITCH TO P910-8 AND P910-9
2. CONNECT HOOKSWITCH TO P910-5 AND P910-8 FOR TYPE 99 DECODER.
3. CONNECT HOOKSWITCH TO P910-8 AND P911-5 FOR DC REMOTE.

EXTERNAL SPEAKER APPLICATION

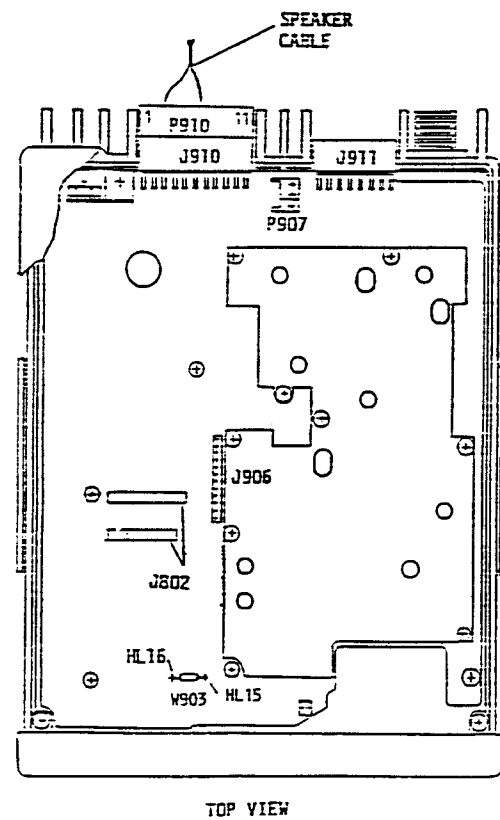

NOTES:

1. CONNECT SPEAKER LEADS TO P910-3 AND P910-7. TO DISCONNECT INTERNAL SPEAKER (FIELD ONLY) REMOVE W903 BETWEEN HL5 & HL6.
2. FOR EXTERNAL SPEAKER WITH THE AC POWER SUPPLY, REMOVE JUMPER IN POWER CABLE BETWEEN P910-3 & P910-10 AND CONNECT PER NOTE 1.

INSTALLATION DIAGRAM

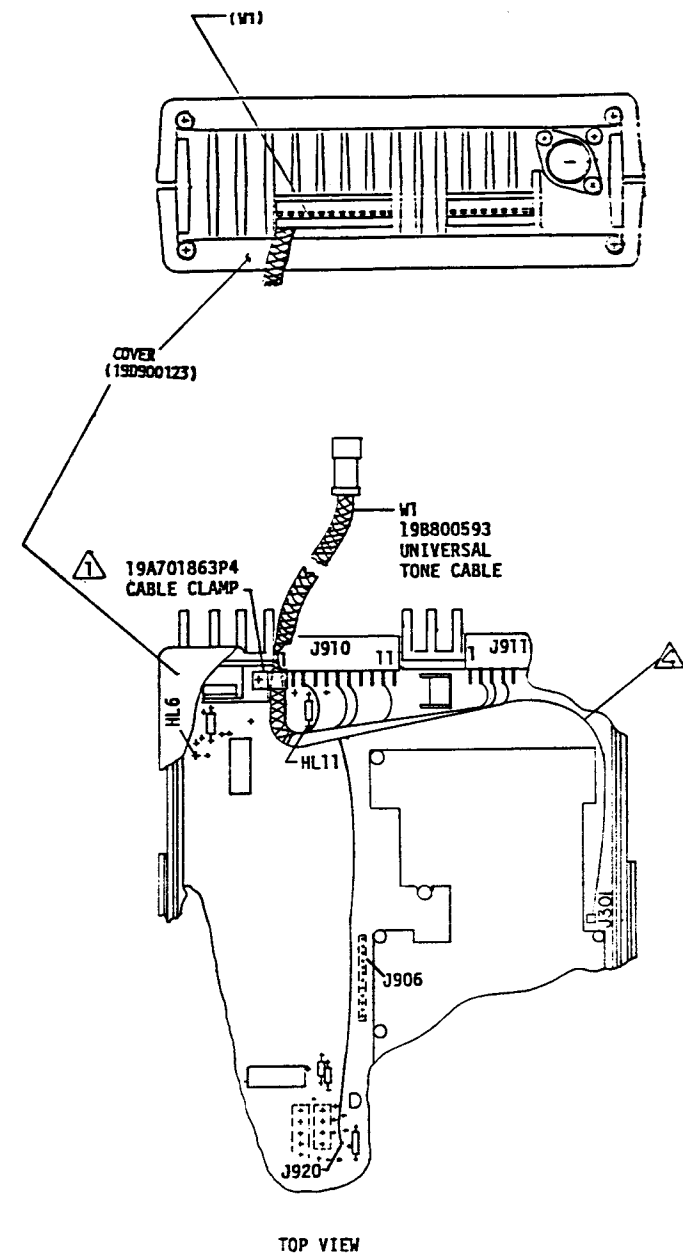

- 12 UNIVERSAL TONE CABLE NOTES:
- 1 PART OF CABLE KIT 19B800593
 - 2 DISCARD RUBBER CHANNEL SUPPLIED IN KIT
 - 3 WHEN THE TONE CABLE IS USED WITH THE PUBLIC ADDRESS OPTION (P10), CONNECT ORANGE WIRE TO HL 11 AND THE WHITE-GREEN WIRE TO HL6
 - 4 WHEN THE UNIVERSAL TONE CABLE IS USED WITH EXTERNAL CHANNEL GUARD ENCODE OPTION, REMOVE W-6 (SHIELDED) CONDUCTOR FROM J911-4 AND CONNECT A 5 IN. PIECE OF #22 AWG WIRE BETWEEN THE END OF THE W-6 (SHIELDED) CONDUCTOR AND J301. SLEEVE THE IN-LINE SOLDER JOINT TO PREVENT SHORTS.

TONE CABLE TO RADIO CONNECTION CHART

FROM	TO	WIRE COLOR	NOTES
W1	J910-3	0	SOLDER
W1	J910-6	4-0	SOLDER
W1	J910-7	3K	SOLDER
W1	J910-10	4-G	SOLDER
W1	J911-2	4-0-R	SOLDER
W1	J911-3	SHIELD	SOLDER
W1	J911-4	W-6 (SHIELDED)	SOLDER
W1	J920	W-BR	SOLDER

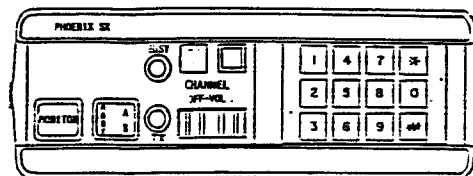
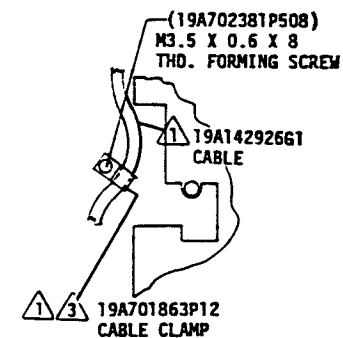
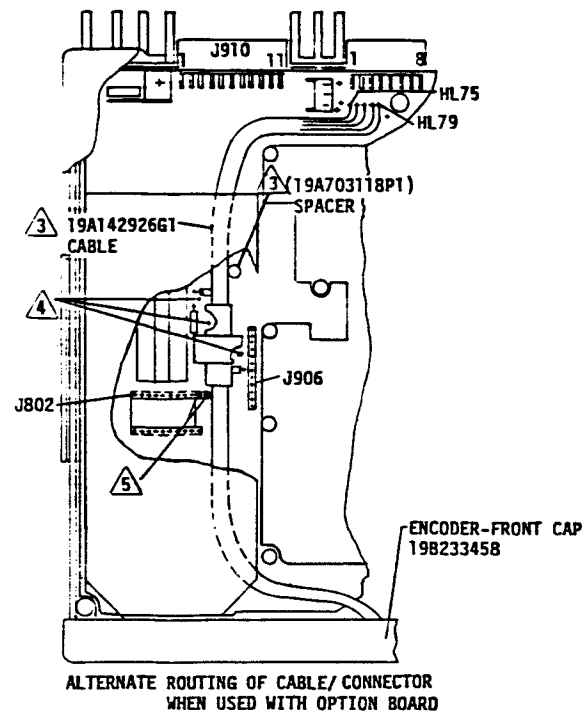

DTMF ENCODER CONNECTION CHART

WIRE COLOR	CONNECT TO	NOTES
BK	HL75	SOLDER
BL	HL76	SOLDER
SHIELD	HL77	SOLDER
G	HL78	SOLDER
R	HL79	SOLDER

- 13 DTMF ENCODER NOTES:
- 1 PART OF PL19B233458.
 - 3 SPOT TIE CABLE TO SPACER. DISCARD CABLE CLAMP WHEN SPACER IS USED.
 - 4 CUT OFF JACKS J806, J810, J902 TO 2.5MM (0.1 INCH) AS REQUIRED FOR CONNECTOR FIT BETWEEN OPTION BOARD AND SYNTHESIZER BOARD.
 - 5 SLEEVE J802-20 & 21 TO PREVENT SHORT TO DTMF CABLE CONNECTOR.

INSTALLATION DIAGRAM
UNIVERSAL TONE CABLE
DTMF ENCODER

CHANNEL MEMORY (15 ma CONTINUOUS BATTERY DRAIN APPLIED ONLY WITH MASK VERSION OF U801 (NOR 19A703134))

CHANNEL MEMORY (200 ma CONTINUOUS BATTERY DRAIN)

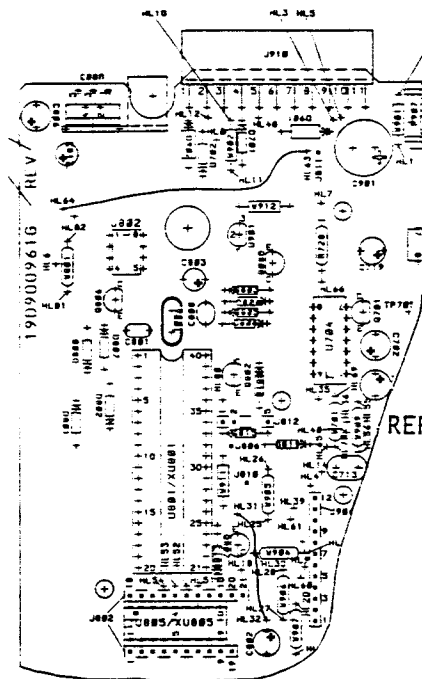

REF 19D901205
19D900961
SYNTHESIZER/
INTERCONNECT BD

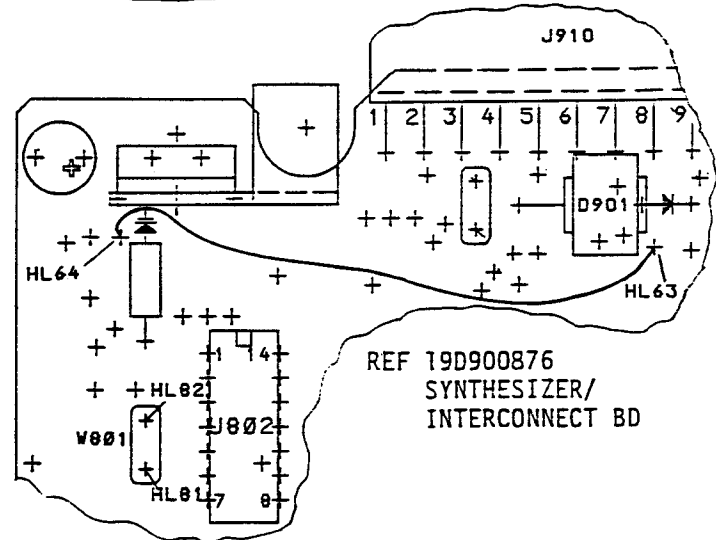

REF 19D900876
SYNTHESIZER/
INTERCONNECT BD

16 CHANNEL MEMORY (200 MA MAX CONTINUOUS BATTERY DRAIN) USED WITH UV ERASABLE MICRO U801. 19A703134 ONLY.

NOTES:

1. ADD JUMPER SN22-W FROM HL63 TO HL64.
2. REMOVE JUMPER (W801) FROM HL81 TO HL82.
3. REMOVE W911
4. ADD JUMPER BETWEEN HL31 AND HL32

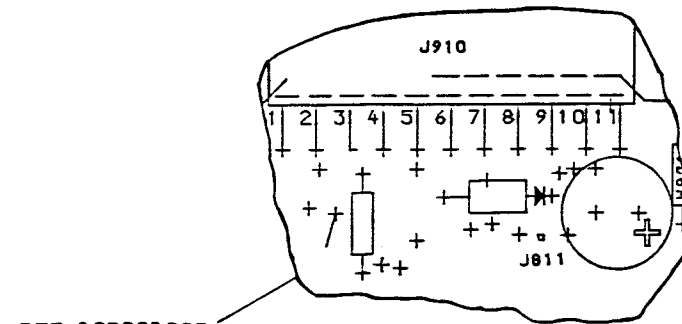

REF 19D901205
19D900961
SYNTHESIZER/
INTERCONNECT BD

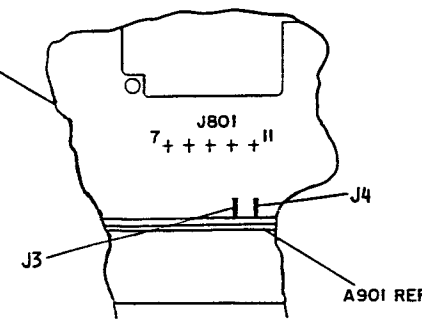
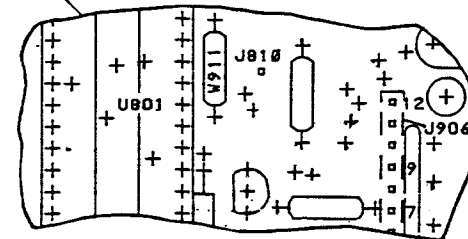

FIELD NOTE
FOR SYNTHESIZER/INTERCONNECT BDS WITHOUT U901.

15 CHANNEL MEMORY (15 MA CONTINUOUS BATTERY DRAIN APPLIED ONLY WITH MASK VERSION OF U801 (NOT 19A703134))

NOTES:

1. ADD JUMPER SN22-W FROM A901-J4 TO J810.
ADD JUMPER SN22-W FROM A901-J5 TO J811.
2. REMOVE W911.

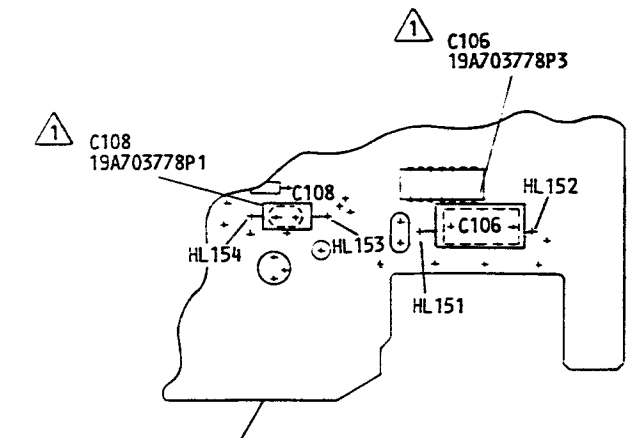

19D901205 REF
SYNTHESIZER BD.

19 SCAN MODIFICATION

1 REMOVE C106 AND C108 AND REPLACE WITH PARTS SUPPLIED IN MOD KIT 19A70392261.

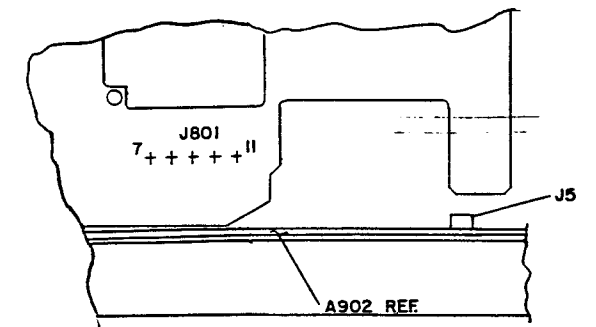

INSTALLATION DIAGRAM

PARTS LIST
LBI31249G
PHOENIX S, SX AND PSX-200
ASSOCIATED PARTS AND ASSEMBLIES

SYMBOL	GE PART NO.	DESCRIPTION
	19B801032P1	Nameplate. (PHOENIX SX).
	19B801032P2	Nameplate. (PHOENIX S).
	19C851078P1	Faceplate. (CHANNEL, OFF-VOL-PA-TX).
	19C851078P2	Faceplate. (CHANNEL, OFF-VOL-CALL-TX).
	19C851078P3	Faceplate. (CHANNEL, OFF-VOL-PA-TX).
	19C851078P4	Faceplate. (CHANNEL, OFF-VOL-CALL-TX).
	19C851078P5	Faceplate. (CHANNEL, OFF-VOL-CALL-TX).
	19C851078P6	Faceplate. (CHANNEL, OFF-VOL-BUSY-TX).
	19C851078P7	Faceplate. (CHANNEL, OFF-VOL-BUSY-TX).
	19C851078P8	Faceplate. (CHANNEL, OFF-VOL-CALL-TX).
	19C851078P9	Faceplate. (PWR, OFF-VOL-PA-TX).
	19C851078P10	Faceplate. (PWR, OFF-VOL-CALL-TX).
	19C851078P11	Faceplate. (PWR, OFF-VOL-BUSY-TX).
	19C851078P12	Faceplate. (PWR, OFF-VOL-PA-TX).
	19C851078P13	Faceplate. (PWR, OFF-VOL-CALL-TX).
	19C851078P14	Faceplate. (PWR, OFF-VOL-BUSY-TX).
	19C851078P15	Faceplate. (PWR, OFF-VOL-CALL-TX).
	19C851078P16	Faceplate. (PWR, OFF-VOL-CALL-TX).
	19C851078P17	Faceplate. (CHANNEL, OFF-VOL-PA-TX).
	19C851078P18	Faceplate. (CHANNEL, OFF-VOL-PA-TX).
	19C851078P19	Faceplate. (PWR, OFF-VOL-PA-TX).
	19C851078P20	Faceplate. (PWR, OFF-VOL-PA-TX).
	19A701530G3	Transmit/Receive Shield.
	19A701531G1	Frequency Synthesizer, Audio Processor Shield.
	19D900123P2	Top Cover.
	19B800716P2	Tuning tool.
	19B800593G1	Universal Tone Cable. (Encode or Decode).
		----- MICROPHONES -----
	19B801398P3	Microphone.
	19C850857P2	Microphone: Transistorized. (Electret cartridge); sim to PRIMO DM-1532 with EM-96 cartridge). (Phoenix Style).
	7141414G2	Microphone mounting kit.
		TRANSISTORIZED MICROPHONE 19D900141G5
	19B800741P3	Microphone: Transistorized. (Electret cartridge); sim to Primo EM-60.
	19A116659P20	Connector; sim to Molex 09-50-3081.
	19A116781P6	Contact, electrical: wire range No. 22-26 AWG; sim to Molex 08-50-0108.
	NP280909P1	Nameplate. (GENERAL ELECTRIC).
		RUGGEDIZED MICROPHONE 19B233577P1 BLACK 19B233577P2 PEBBLE
	RP117	Transistorized cartridge.
	RP128	Switch assembly.

SYMBOL	GE PART NO.	DESCRIPTION
	RP261	Switch button. (BLACK).
	RP277	Switch button. (PEBBLE).
	RP262	Case set. (BLACK).
	RP275	Case set. (PEBBLE).
	RP263	Cable assembly. (Includes connector shell 19A116659P20 and 4 contacts 19A116781P6).
	RP276	Chassis assembly, inner module.
		DESK MICROPHONE (CHANNEL GUARD) 19B209694P1
	RP119	Switch Kit. (Includes switch, transmit and monitor pushbuttons, locking spring, retainer and spring, and two thread forming screws.
	19A116659P20	Cable connector shell; sim to Molex 09-50-3081.
	19A116781P6	Contact, electrical: wire range No. 22-26 AWG; sim to Molex 08-50-0108. (Quantity 5 - Used with 19A116659P20 connector shell).
	NP270713	Faceplate. (GENERAL ELECTRIC).
		INTERCONNECT CABLE 19D417126G1
		----- JACKS -----
J1 and J2	7489183P7	Plug: 9 contacts rated at 7.5 amps max; sim to Winchester M9P-LS-H19C.
		----- PLUGS -----
P1	7489183P10	Plug: 9 contacts rated at 7.5 amps max; sim to Winchester M9P-LS-H19C.
		FUSED LEAD ASSEMBLY 19A137818G10
	1R16P5	Quick blowing: 2 amp at 250 v; sim to Littelfuse 312002 or Bussmann AGC-2.
	19A115776P6	Fuseholder: sim to Bussmann 9835.
	19A115776P5	Fuse housing cap.
	19A115776P7	Spring: sim to Bussmann 1A1853. (Located in fuse housing).
	19A115776P8	Contact: sim to Littelfuse 904-88. (Crimped on wire inside fuse housing and cap).
	19A116781P3	Contact, electrical: wire range No. 16-20 AWG; sim to Molex 08-50-0105. (Located on end of lead).
	19B209260P21	Terminal, solderless: wire range No. 16-14, sim to AMP 42752-2.
		POWER CABLE 19B232925G3
		----- PLUGS -----
PS10	19A116659P143	Connector. Includes: Shell.
	19A116781P5	Contact, electrical: wire range No. 18-24 AWG; sim to Molex 08-50-0106.
		FUSED LEAD ASSEMBLY 19A137818G11 (Part of Power Cable 19B232925G3)
	7484390P3	Cartridge, quick blow: 15 amp at 250 v; sim to Bussmann ABC15.
	19A115776P6	Fuseholder: sim to Bussmann 9835.
	19A115776P5	Fuse housing cap.
	19A115776P7	Spring: sim to Bussmann 1A1853. (Located in fuse housing).
	19A115776P8	Contact: sim to Littelfuse 904-88. (Crimped on wire inside fuse housing and cap).

SYMBOL	GE PART NO.	DESCRIPTION
		FRONT CAP ASSEMBLY 19B800577G7, 10
LS901	19A703265P1	Permanent Magnet: 4 ohm imp., 4 watt. (Used in G7 only).
LS901	19A703265P2	Permanent Magnet: 4 ohm imp., 4 watt. (Used in G10 only).
		----- SPEAKERS -----
	4034221P1	Clip. (Secures LS901).
	19A700041P28	Connector. (Used with LS901). Includes: Shell.
	19A700041P26	Contact. (Quantity 2).
		2 AMP 16 FREQUENCY KIT 19A701522G9 2 FREQUENCY 19A701522G10 16 FREQUENCY
		----- JACKS -----
J601B	19A700067P2	Connector, receptacle; sim to Amphenol 83-876-1002.
		----- INDICATORS -----
H902	19A134354P9	Diode, optoelectronic: yellow; sim to Hew. Packard HLMF 4719.
H903	19A134354P3	Diode, optoelectronic: green; sim to Hew. Packard 5082-4955.
		----- MISCELLANEOUS -----
	19A701744P3	Pad. (Located at Tx switch).
	19B800719P1	Dust pad. (located behind J910 & J911).
	19J706212P101	Screw. (Secures Display Board).
	19A701328P1	Spacer, bushing. (Used with LED-PWR).
	19B232859P1	Bushing. (Used with LED - BUSY/Tx).
	19B702381P520	Screw. (Secures shields).
	19A702364P310	Screw. (Secures covers at rear).
	19A702381P508	Screw, thd. form: No. 3.5-0.6 x 8. (Secures covers at front & sides).
	19A701312P4	Flatwasher: 3.2 IC. (Secures covers at rear).
	19A700032P5	Lockwasher, internal tooth: No. 3MM. (Secures J601).
	19A121175P33	Insulator, plate.
	19A121175P43	Insulator, plate.
	19A700034P4	Nut, hex: No. M3 x 0.5MM.
	19A703694P1	Washer.
		DASH MOUNTING HARDWARE KIT 19A138051G6 DASH MOUNT
	19A134853P4008	Bolt, machine, hex: Metric, 8MM. (Secures radio to mounting bracket).
	19A700032P7	Lockwasher, internal tooth: M4. (Secures radio to mounting bracket).
	19J706152P9	Retaining strap: sim to Dennison BAR-LOK 08471. (Secures power leads under dash).
	N130P1610B6	Screw, thread forming: No. 10-16 x 5/8. (Secures mounting bracket to thin mounting surface).
	N130P1624B6	Screw, thread forming: No. 10-16 x 1-1/2. (Secures mounting bracket to thick mounting surface).
	5490407P6	Rubber grommet. (Located in fire wall).
	19C850638P3	Mounting bracket.
	4036835P11	Terminal, solderless.
	19B209260P21	Terminal, solderless: wire range No. 16-14; sim to AMP 42752-2.

SYMBOL	GE PART NO.	DESCRIPTION
		FRONT CAP ENCODER 19B233458G4
		----- JACKS -----
J1301	19B209505P205	Connector. Includes: Shell.
	19B209505P21	Contact. (Quantity 5).
		----- PLUGS -----
P1301	19B209505P105	Connector. Includes: Shell.
	19B209505P24	Contact. (Quantity 5).
		----- MISCELLANEOUS -----
	19B209731P2	Encoder. (DTMF); sim to Challenger Electronics PE-0705. (Earlier Models).
	19A142920G1	Encoder. (DTMF).
	19A142926	Interconnect cable.
	19A142673P1	Inner encoder support.
	19A142672P1	Outer encoder support.
	19B233457G4	Front cap.
	19D900129P7	Front cap. (Used w/Dual Priority Scan).
	19A701863P12	Clip loop. (Secures cable).
	19D430583P13	Faceplate.
	19A116773P606	Tap screw, phillips, POZIDRIVE: No. 5-20 x 3/8. (Secures DTMF Encoder).
		EXTERNAL SPEAKER KIT 19A703913G1 CABLE 19A703913G2 CONNECTOR
		----- JACKS -----
J2	19B209288P14	Connector. Includes: Shell.
	19B209288P30	Contact. (Quantity 2).
		----- PLUGS -----
P2	19B209288P12	Connector. Includes: Shell.
	19B209288P29	Contact. (Quantity 2).
		----- PLUGS -----
P904	19A700041P28	Connector. Includes: Shell.
	19A700041P26	Contact. (Quantity 2).

*COMPONENTS ADDED, DELETED OR CHANGED BY PRODUCTION CHANGES

SYMBOL	GE PART NO.	DESCRIPTION
		----- MISCELLANEOUS -----
	19B209731P2	Encoder. (DTMF); sim to Challenger Electronics PE-0705.
	19A142673P1	Inner encoder support.
	19A142672P1	Outer encoder support.
	19B233457G4	Front cap.
	19D900129P7	Front cap. (Used w/Dual Priority Scan).
	19A701863P12	Clip loop. (Secures cable).
	19D430583P13	Faceplate.
	19A116773P606	Tap screw, phillips, POZIDRIV®: No. 5-20 x 3/8. (Secures DTMF Encoder).
		EXTERNAL SPEAKER KIT 19A703913G1 CABLE 19A703913G2 CONNECTOR
		----- JACKS -----
J2		Connector. Includes:
	19B209288P14	Shell.
	19B209288P30	Contact. (Quantity 2).
		----- PLUGS -----
P2		Connector. Includes:
	19B209288P12	Shell.
	19B209288P29	Contact. (Quantity 2).
P904		Connector. Includes:
	19A700041P28	Shell.
	19A700041P26	Contact. (Quantity 2).

PARTS LIST

EXTERNAL ALARM RELAY
19B226025G4
ISSUE 2

SYMBOL	GE PART NO.	DESCRIPTION
CR1701	19A704142P2	----- DIODES AND RECTIFIERS ----- General Purpose Silicon; sim to 1N4005.
K1701	7486515P2	----- RELAYS ----- Armature, enclosed: 12 VDC nominal, 85 to 90 ohms coil res, 1 form A contact rated at 15 amps.
		FUSED LEAD 19B226454G1
	1R16P3	Quick blowing: 1 amp at 250 v; sim to Littelfuse 312001 or Bussmann AGC-1.
	19A115776P6	Fuseholder: sim to Bussmann 9835.
	19A115776P5	Knob assembly: sim to Bussmann 9953 1/2.
	19A115776P7	Spring: sim to Bussmann 1A1853.
	19A115776P3	Contact: sim to Littelfuse 904-88. (Crimped on wires inside holder).
		WIRE ASSEMBLY 19A129937G2
	19B209260P12	Terminal, solderless: wire range No. 22-16; sim to AMP41310.
	19A116781P5	Contact, electrical: wire range No. 18-24 AWG; sim to Molex 08-50-0106.
		----- MISCELLANEOUS -----
	N80P13005C6	Machine screw: No. 6-32 x 5/16. (Secures relay to support).
	N404P13C6	Lockwasher, internal tooth: No. 6. (Secures relay to support).
	N402P37C13	Flatwasher: No. 6. (Secures relay to support).
	N80P15005C6	Machine screw, phillips head: No. 8-32 x 5/16. (Secures wire to relay terminals).
	19A129833P1	Support. (K1701).
	N130P1608C6	Tap screw: No. 10-16 x 1/2. (Secures relay support).

PARTS LIST

MIKE HANGER/HOOKSWITCH
19C320318G4
ISSUE 2

SYMBOL	GE PART NO.	DESCRIPTION
S2	19A116676P1	----- SWITCHES ----- Sensitive: SPDT, 5 amps at 24 VDC or 5 amps at 250 VRMS; sim to Microswitch 111SM1-T2.
W1	19A129414G1	----- CABLES ----- 2 conductor cable: approx 5 feet long, includes (2) 19A116781P5 contacts.
		----- MISCELLANEOUS -----
	19B219694P1	Base plate.
	19B219698G5	Housing.
	19A702464P2	Strain relief. (W1).
	N193P1410C6	Tap screw, phillips head: No. 8-18 x 5/8. (Secures assembly to mounting surface).
		ASSOCIATED PARTS
		MIKE KIT 7141414G2
	4031457P1	Support.
	4031458P1	Spring.
	N193P1408C6	Tap screw, phillips head: No. 8-18 x 1/2.
	19A116773P105	Tap screw, phillips POZIDRIV®: No. 7-19 x 5/16.

*COMPONENTS ADDED, DELETED OR CHANGED BY PRODUCTION CHANGES

*COMPONENTS ADDED, DELETED OR CHANGED BY PRODUCTION CHANGES

PARTS LIST

3 x 5 INCH SPEAKER
 19C850550G1 DASH MOUNT - 4 OHM
 19C850550G2 WINDOW MOUNT - 4 OHM
 19C850550G3 DASH MOUNT - 8 OHM
 19C850550G4 WINDOW MOUNT - 8 OHM
 ISSUE 4

PARTS LIST

UNIVERSAL TONE CABLE
 19B800593G1
 ISSUE 3

PARTS LIST

132-512 MHz ANTENNA
 19B209568P1
 ISSUE 2

SYMBOL	GE PART NO.	DESCRIPTION
		----- LOUDSPEAKERS -----
LS1	19A702080P3	Permanent magnet: 3 x 5 inch, 4 ohms ±10% imp at 400 Hz, 18 w.
LS2	19A702080P4	Permanent magnet: 3 x 5 inch, 8 ohms ±10% imp at 400 Hz, 18 w.
		----- CABLES -----
W1	19A129414G1	2 conductor cable: approx 5 feet long, includes (2) 19A116781P5 contacts.
W2	19B226189G1	Window mount: approx. 17 inches retracted, 84 inches extended. (Includes 2 19A116781P5 contacts).
		BREAKAWAY MOUNTING KIT 19A129461G1
	19C320022P1	Retaining bracket. (With locking jaws).
	19B219578G1	Safety Release Disc. (Mates with mounting surface).
	N187P16010C6	Machine screw, hexhead, slotted: No. 10-32 x 5/8. (Quantity 1 - Used with safety release disc with retaining bracket).
	N130P1612C6	Tap screw, thd. forming: No. 10-16 x 3/4. (Quantity 3 - Used without safety release disc & retaining bracket).
	N130P1624C6	Tap screw, thd. forming: No. 10-16 x 1-1/2. (Quantity 3 - Used without safety release disc & retaining bracket - for extra thick carpet).
	N402AP9C6	Flatwasher: No. 10. (Used with 10-16 thread forming screws).
		DASH MOUNT KIT FOR WINDOW MOUNT SPEAKER OPTION 19A130023G1 & G2
	19B226192G1	Housing. (G1 only).
	19B226190P1	Backing plate.
	19B226185P1	Clip bracket.
	N193P1408C6	Tap screw, phillips head: No. 8-18 x 1/2. (Secures backing plate to mounting surface).
		----- MISCELLANEOUS -----
	19B800534G1	Housing. (DASH MOUNT).
	19B800534G2	Housing. (WINDOW MOUNT).
	19C850549P1	Grille.
	19A702464P3	Strain relief. (Used with W1 window mount cable at housing).
	19A701354P2	Nameplate. (GENERAL ELECTRIC).
	19C320016P1	Mounting bracket. (Secures speaker assembly to mounting surface).
	19A701631P516	Machine screw: No. 10-32 x 5/16. (Secures speaker housing to mounting support).
	19A701312P7	Lockwasher: No. 10. (Secures speaker housing to mounting support).
	19A700033P10	Lockwasher, external tooth: No. 10. (Secures speaker housing to mounting support).
	19A116986P112	Screw, thread forming, assembled washer: Phillips POZIDRIV®, HI-LO thread, No. 7-19 x 3/4. (Secures grille to housing).

SYMBOL	GE PART NO.	DESCRIPTION
	7489183P7	Plug: 9 contacts rated at 7.5 amps max; sim to Winchester M9P-LS-H19CS.
	19A701863P4	Cable clip: sim to Weckesser Co. 3/16-4-128.
	19A701430G1	Rubber channel.
	19A700136P6	Insulated sleeving, electrical. (Specify length).
	7134854P4	Wire stranded. (Shield).
	19A115871P1	Wire, stranded, white-orange.
	19A115871P3	Wire, stranded, white-brown.
	19A115871P5	Wire, stranded, white-green.
	19A115871P9	Wire, stranded, white-orange-red.
	19A115871P29	Wire, stranded, orange.
	19A115871P30	Wire, stranded, black.

SYMBOL	GE PART NO.	DESCRIPTION
		Whip assembly. Decibel Products 068110-001.
		Whip nut assembly. Decibel Products 068047-001.
		Base nut assembly. Decibel Products 068048-001.
		"O" Ring (LARGE). Decibel Products 007059-122.
		Stud assembly. Decibel Products 068046-001.
		BG58/U Cable, 15 feet. Decibel Products 068115-001.

*COMPONENTS ADDED, DELETED OR CHANGED BY PRODUCTION CHANGES