



MAINTENANCE MANUAL SYSTEM BOARD 19D901891G1

TABLE OF CONTENTS

	<u>Page</u>
DESCRIPTION	1
CIRCUIT ANALYSIS	1
OUTLINE DIAGRAM	2
SCHEMATIC DIAGRAM	3
PARTS LIST	4
IC DATA	5

S
Y
S
T
E
M

DESCRIPTION

The System Board provides A+ switching to all boards in the MDR, MTD, MVS, TMX-8810, and TMX-8825 Mobile Radio Assemblies. Main power for the radio is routed through J1 to the System Board where it is distributed throughout the radio. A power distribution block diagram is provided in the service manual.

All options for the radio are routed through the System Board and may be interconnected to the radio through option connector J905. A slotted opening is provided for the option cable at the rear of the radio adjacent to the power cable.

The System Board is equipped with a public address microphone amplifier for use with the public address option when applicable (not used in MDR, MTD, TMX). This amplifier provides typically +20dB gain. A FET audio gate allows muting of the public address audio when the option is disabled.

Speaker audio is routed through the System Board and connects to the speaker in the Front Cap Assembly via J904. An alternate speaker connection is provided on the Control Board.

CIRCUIT ANALYSIS

POWER DISTRIBUTION

Main power to the radio is supplied by the System Board and is interconnected to the radio by J1. An ignition sense lead provides a means for applying or removing power from the radio with the ignition switch of the vehicle. Refer to the Installation Manual for a detailed description of power connections.

The A+ switching circuitry consists of a digital logic circuit and a power MOSFET. The low current logic circuit receives power continuously from the A+ lead from the battery to "remember" if the radio was left on or off when controlled by the ignition sense lead. C901 provides several minutes of memory when A+ is completely removed or when A+ dips to a low voltage while starting the vehicle engine.

The power switch input line J902-13 is normally at 13 volts and is momentarily grounded when the power switch is pressed. This ground turns on Q901 which supplies 13 volts to the clock lead of U901. The Q output of the D-type flip-flop U901-1 alternately toggles high or low each time the clock lead goes high. R906 and C904 provide a time delay to debounce the power switch.

To turn the radio on, 13 volts must be present on the ignition sense lead of J1. The power switch must toggle the Q output of U901 to the high state to prevent grounding the ignition sense voltage through D902-A. The voltage is then able to forward bias D902-B and turns on Q902. Q902 grounds the gate of MOSFET Q903. Q903 turns on, supplying switched A+ through fuse F901 to the other boards in the radio. The 3 amp fuse protects the radio and any options from high current failures.

Switched A+ also feeds 8 volt regulator U902 which provides voltage for the public address microphone amplifier (not used in MDR, MTD, and TMX). U903B provides a low noise 4.4 volt bias voltage to the mic amplifier U903A. The amplifier has a gain of 10 (20dB). Receiver audio from the Audio Board is attenuated 12dB by R918 and R919 and leaves the System Board on the attenuated RX audio output. When the Public Address option is turned on and the microphone is keyed, FET Q904 turns on and passes the amplified mic audio from U903A to the attenuated RX audio output. This output feeds the volume control and 3 watt audio PA on the Control Board in the Front Cap Assembly.

COMPONENT SIDE

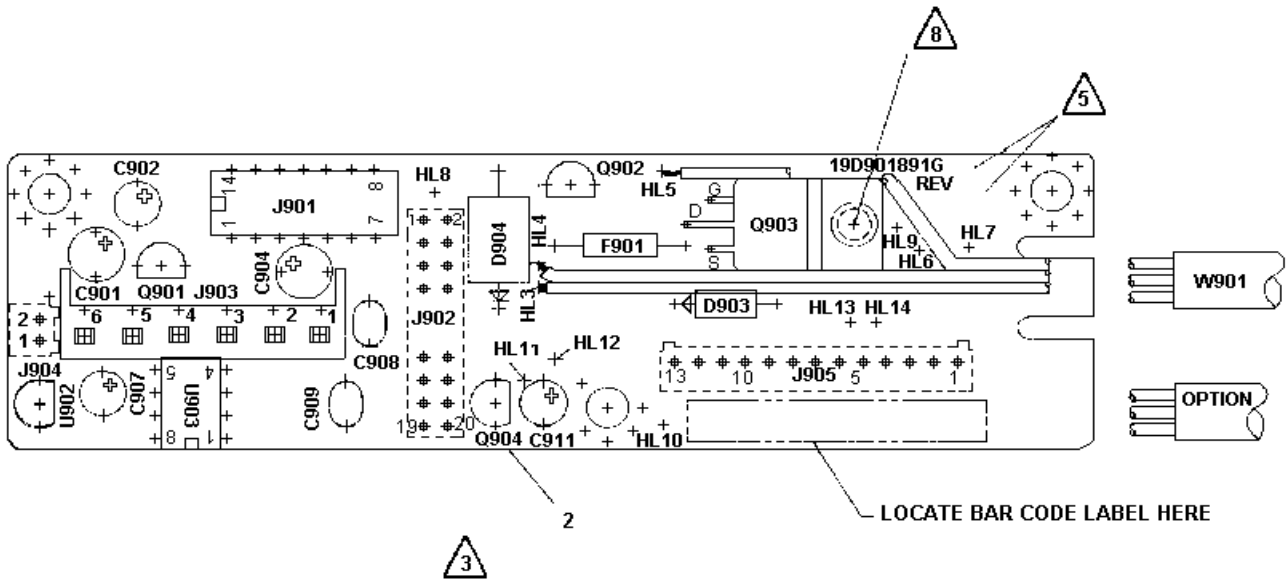

(19D901891, Sh. 1, Rev. 7)



SOLDER SIDE

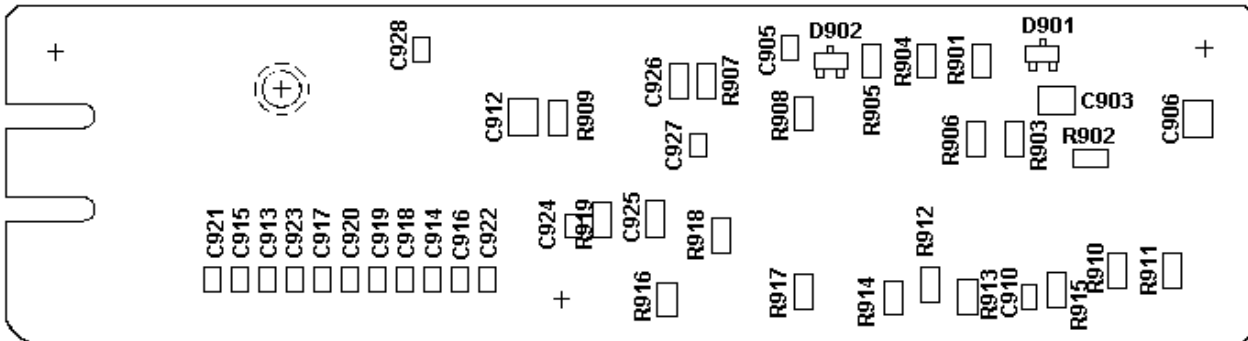

(19D901891, Sh. 1, Rev. 7)

LEAD IDENTIFICATION FOR Q901 AND Q907



IN-LINE TOP VIEW

NOTE: CASE SHAPE IS DETERMINING FACTOR FOR LEAD IDENTIFICATION.

LEAD IDENTIFICATION FOR Q904



IN-LINE TOP VIEW

NOTE: CASE SHAPE IS DETERMINING FACTOR FOR LEAD IDENTIFICATION.

LEAD IDENTIFICATION FOR U902



IN-LINE TOP VIEW

NOTE: CASE SHAPE IS DETERMINING FACTOR FOR LEAD IDENTIFICATION.

LEAD IDENTIFICATION FOR D901 AND D902



TOP VIEW

SYSTEM BOARD
19D901891G1

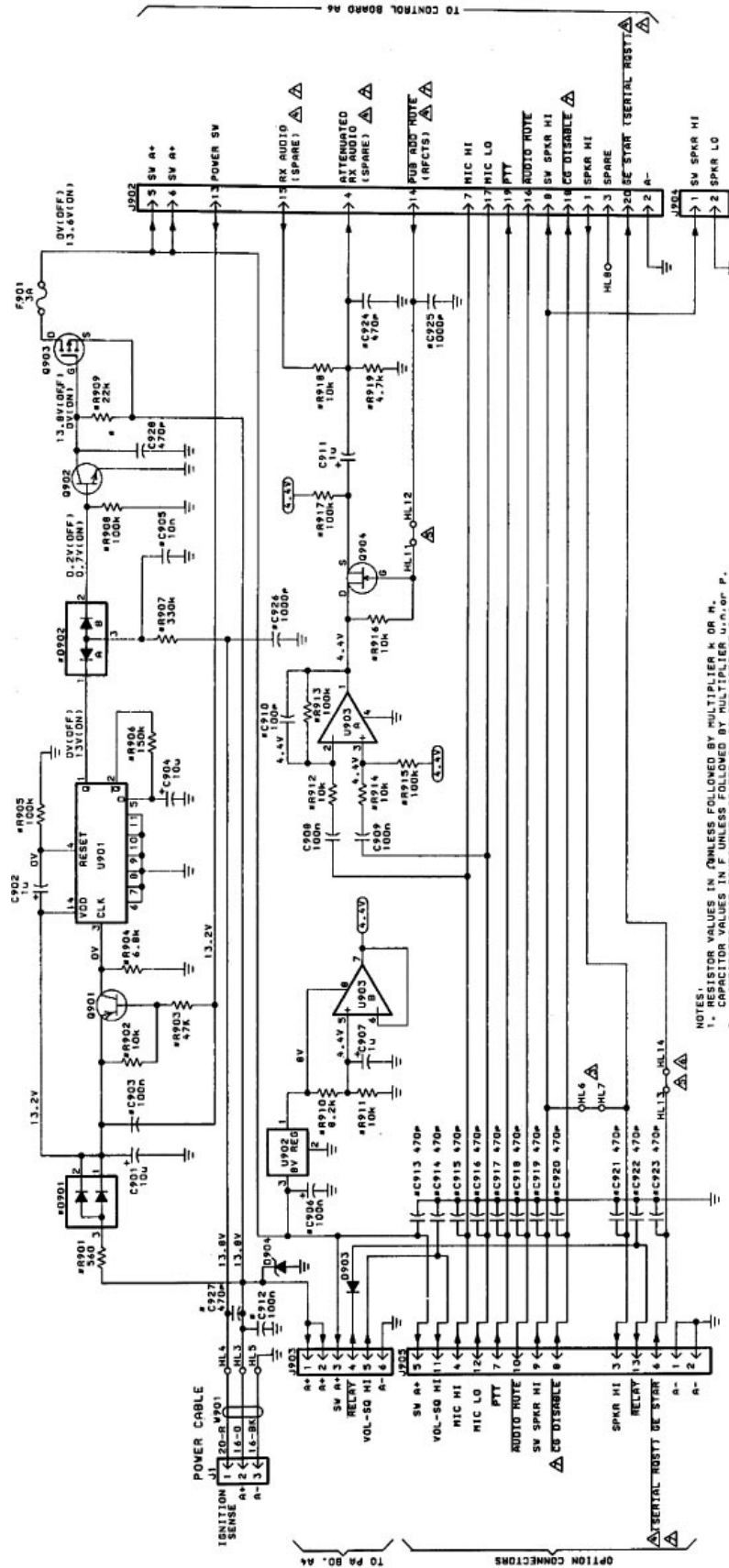

- NOTES:
- 1. RESISTOR VALUES IN Ω UNLESS FOLLOWED BY MULTIPLIER K OR M. CAPACITOR VALUES IN F UNLESS FOLLOWED BY MULTIPLIER U, μ , OR P.
 - 2. * INDICATES CHIP COMPONENT LOCATED ON SOLDER SIDE OF PCB.
- Δ CUT RUN BETWEEN HOLES 6 AND 7 TO DISABLE INTERNAL SPEAKER CAPABILITY.
 Δ LINE NAMES IN () FOR THX-8925 AND HTD.
 Δ FOR 9825 DATA OPTION CUT RUNS BETWEEN HL11 & HL12 AND HL13 & HL14.
 Δ ADD JUMPER BETWEEN HL12 AND HL13.
 Δ FOR MVS DATA OPTIONS CUT RUN BETWEEN HL13 AND HL14.
 Δ MDR SPARE.

MODEL NO.	REV. LETTER
19D901891G1	0

**SYSTEM BOARD
19D901891G1**

(19D901982, Rev. 9)

**SYSTEM BOARD
19D901891G1
ISSUE 5**

SYMBOL	PART NO.	DESCRIPTION
----- CAPACITORS -----		
C901	19A701534P7	Tantalum: 10 µF ±20%, 16 VDCW.
C902	19A701534P4	Tantalum: 1 µF ±20%, 35 VDCW.
C903	19A702052P26	Ceramic: 0.1 µF ±10%, 50 VDCW.
C904	19A701534P7	Tantalum: 10 µF ±20%, 16 VDCW.
C905	19A702052P14	Ceramic: 0.01 µF ±10%, 50 VDCW.
C906	19A702052P26	Ceramic: 0.1 µF ±10%, 50 VDCW.
C907	19A701534P4	Tantalum: 1 µF ±20%, 35 VDCW.
C908 and C909	19A700121P106	Ceramic: 0.1 µF ±20%, 50 VDCW.
C910	19A702061P61	Ceramic: 100 pF ±5%, 50 VDCW, temp coef 0 ±30 PPM.
C911	19A701534P4	Tantalum: 1 µF ±20%, 35 VDCW.
C912	19A702052P26	Ceramic: 0.1 µF ±10%, 50 VDCW.
C913 thru C924	19A702061P77	Ceramic: 470 pF ±5%, 50 VDCW, temp coef 0 ±30 PPM.
C925 and C926	19A702061P99	Ceramic: 1000 pF ±5%, 50 VDCW, temp coef 0 ±30 PPM/°C.
C927 and C928	19A702061P77	Ceramic: 470 pF ±5%, 50 VDCW, temp coef 0 ±30 PPM.
----- DIODES -----		
D901 and D902	19A703561P2	Silicon, fast recovery (2 diodes in series).
D903	T324ADP1041	Silicon: Rectifier; sim to 1N4004.
D904	19A703588P3	Zener, transient suppressor: sim to 1N6278A.
----- FUSES -----		
F901	19A702169P9	Enclosed link: rated 3 amps @ 125 v; sim to Littelfuse 255003.
----- JACKS -----		
J902	19A703248P11	Post: Gold Plated, 10 mm length.
J903	19A705245P1	Printed wire: 6 contacts, sim to Molex 10-02-1062.
J904 and J905	19A703248P11	Post: Gold Plated, 10 mm length.
----- TRANSISTORS -----		
Q901	19A700022P2	Silicon, PNP: sim to 2N3906.
Q902	19A700023P2	Silicon, NPN: sim to 2N3904.
Q903	19A705325P1	MOSFET, P-Channel: sim to Seimens BUZ171.
Q904	19A134137P7	N-type, field effect.
----- RESISTORS -----		
R903	19B800607P473	Metal film: 47K ohms ±5%, 1/8 w.
R904	19B800607P682	Metal film: 6.8K ohms ±5%, 1/8 w.
R905	19B800607P104	Metal film: 100K ohms ±5%, 1/8 w.
R906	19B800607P154	Metal film: 150K ohms ±5%, 1/8 w.
R907	19B800607P334	Metal film: 330K ohms ±5%, 1/8 w.
R909	19B800607P223	Metal film: 22K ohms ±5%, 1/8 w.

SYMBOL	PART NO.	DESCRIPTION
R910	19B800607P822	Metal film: 8.2K ohms ±5%, 1/8 w.
R911 and R912	19B800607P103	Metal film: 10K ohms ±5%, 1/8 w.
R913	19B800607P104	Metal film: 100K ohms ±5%, 1/8 w.
R914	19B800607P103	Metal film: 10K ohms ±5%, 1/8 w.
R915	19B800607P104	Metal film: 100K ohms ±5%, 1/8 w.
R916	19B800607P103	Metal film: 10K ohms ±5%, 1/8 w.
R917	19B800607P104	Metal film: 100K ohms ±5%, 1/8 w.
R918	19B800607P103	Metal film: 10K ohms ±5%, 1/8 w.
R919	19B800607P472	Metal film: 4.7K ohms ±5%, 1/8 w.
----- INTEGRATED CIRCUITS -----		
U901	19A700029P9	Digital: Dual Data Flip-Flop; sim to 4013B.
U902	19A704073P2	Linear: 8 Volt Regulator; sim to MC78L08CP.
U903	19A700086P2	Linear: Dual Op Amp; sim to 1458.
----- CABLES -----		
W901	19C851585P1	Cable.

PRODUCTION CHANGES

Changes in the equipment to improve performance or to simplify circuits are identified by a "Revision Letter", which is stamped after the model number of the unit. The revision stamped on the unit includes all previous revisions. Refer to the Parts List for the descriptions of parts affected by these revisions.

REV. A - SYSTEM BOARD 19D901891G1
Included in initial shipment.

REV. B - SYSTEM BOARD 19D901891G1
To eliminate RF interference, added C927 and C928, relocated R903 and R906 and eliminated ground from printed wire board edge.

REV. C - SYSTEM BOARD 19D901891G1
To provide transient protection, added D903. To provide for Data Option added holes in RFCTS line.

REV. D - SYSTEM BOARD 19D901891G1
To provide transient protection, added D904.

*COMPONENTS, ADDED, DELETED, OR CHANGED BY PRODUCTION CHANGES

DUAL "D" FLIP FLOP WITH RESET
U901 (4013D)

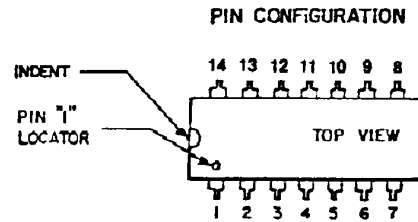
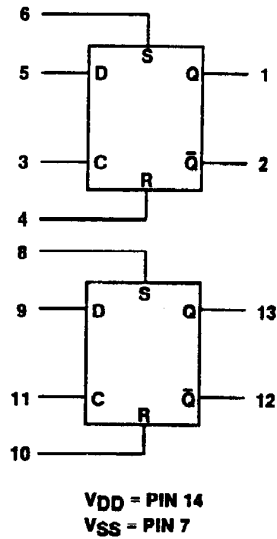

S
Y
S
T
E
M

VOLTAGE REGULATOR U902 (MC78L08CP)

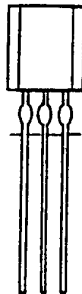

BOTTOM VIEW
PIN 1 - OUTPUT
PIN 2 - GROUND
PIN 3 - INPUT

OPERATIONAL AMPLIFIER U903 (1458)

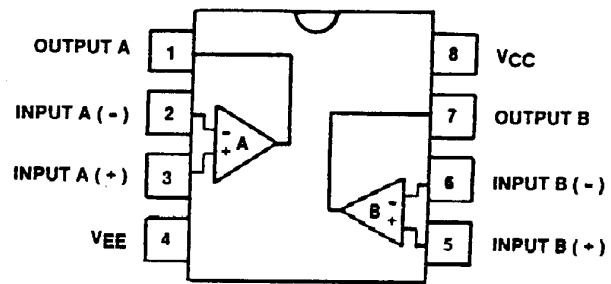

Ericsson GE Mobile Communications Inc.
Mountain View Road • Lynchburg, Virginia 24502