

# MAINTENANCE MANUAL

## AUDIO BOARD 19D901870G1

### FOR MVS

A  
U  
D  
I  
O

#### TABLE OF CONTENTS

DESCRIPTION .....	1
CIRCUIT ANALYSIS	
Receiver Squelch Path .....	1
Receiver Audio Path .....	2
Tone Path .....	2
Receiving Tones .....	4
Transmitting Tones .....	4
Transmitter Audio Path .....	4
Supply Regulators .....	5
SERVICE NOTES .....	5
BLOCK DIAGRAMS .....	3, 6, 7
OUTLINE DIAGRAM .....	8
SCHEMATIC DIAGRAM .....	9
PARTS LIST .....	10
IC DATA .....	10

#### DESCRIPTION

Audio Board 19D901870G1 (A3) interfaces through the Logic Board (A1) to provide all audio and tone processing for the receiver and transmitter, except the receiver volume control and 3 watt audio PA. The board also contains the receiver squelch circuit which is internally adjustable. The Audio Board obtains all control signals from the Logic Board. Refer to Figure 1 for an overall block diagram of the Audio Board.

The Audio Board is located under the top cover of the radio and is mounted above the Logic Board. The board plugs into the Logic Board by an 18 pin connector. Refer to the combination manual for a complete mechanical layout and inter-connection diagram.

The Audio Board contains 4 main paths: a receiver squelch path, a receiver audio path, a tone path, and a transmitter audio path. Refer to Figure 2 for a block diagram of the Receiver Squelch Path and Receiver Audio Path. Figure 3 provides a block diagram of the Tone Path and Transmitter Audio Path.

#### CIRCUIT ANALYSIS

##### RECEIVER SQUELCH PATH

The squelch circuit monitors the level of high frequency noise on the receiver output to determine if a carrier is quieting the receiver. A squelch adjustment sets the noise threshold level required to operate the squelch circuit (normally at 8dB SINAD). When the noise falls below the threshold level, the carrier activity sensor (CAS) output switches to

5 volts. This CAS signal feeds the microprocessor on the Logic Board. The squelch path consists of a high pass filter, a noise rectifier/amplifier, and a comparator.

VOL-SQ HI (J703-7) is the unfiltered receiver audio input from the RF Board. A 6 kHz high pass filter removes all voice signals from the VOL-SQ HI input. The 3 pole filter consists of the circuitry around U601-A. The filter provides a gain of 2 (6dB) at 8-10 kHz and drops 3dB in gain at the 6 kHz cut-off frequency.

Noise in the 6-8 kHz range is coupled to the Squelch Adjust R602, which varies the level of noise to the noise rectifier/amplifier U601-B. U601-B is biased at ground, amplifying only the positive peaks of the noise by about 9dB.

The rectified noise is filtered by R605, C605, and C606 to provide an average DC level proportional to the noise level. This DC level is applied to the inverting (-) input of comparator U602-A. The non-inverting (+) input of U602-A is referenced to 100 mVdc.

When the DC noise level falls below 100 mVdc, the comparator output switches the CAS line to +5 Vdc to tell the Logic Board's microprocessor the channel is busy with a carrier. The comparator output will remain at a logic high until the DC noise level exceeds 140 mVdc. This difference in voltage between the CAS turn-on and turn-off points provides sufficient hysteresis to eliminate "bubbling" or chattering noise in the speaker. The "bubbling" would normally be caused by transitional changes in the DC level around the reference point. The hysteresis is provided by R610.

The RF Board VOL-SQ HI level varies slightly over temperature which would normally cause the squelch threshold to vary. The diodes in D601 slightly vary the 100 mVdc reference voltage to stabilize the squelch threshold over a wide temperature range.

Transistor Q601 is normally turned on, placing C605 in the DC noise averaging circuit. C605 provides a conventional slow (60 msec) squelch operation to prevent chopping the audio with rapid squelch closings in weak signal areas. When the radio is placed into scan operation, Q601 is turned off by the FAST SQ line going low. Only C606 is in the circuit, allowing the squelch to respond quickly (5 ms) while sampling the channels for activity.

RECEIVER AUDIO PATH

Unfiltered receiver audio from the RF Board (VOL-SQ HI) is high pass filtered, muted, de-emphasized, and amplified by the receiver audio path on the Audio Board. The processed receiver audio is routed through the System Board to the Front Cap Assembly where the volume control and 3 watt audio PA are located.

VOL-SQ HI feeds a 300 Hz high pass Channel Guard tone filter (U601-C and D). The filter prevents the low frequency Channel Guard tones (below 210 Hz) from passing to the speaker. The output of the first section of the filter (U601-C pin 8) cuts off sharply at 300 Hz and provides a deep notch at 200 Hz. The second section (U601-D) provides additional rejection of CG tones. The entire filter has a gain of 1 (0 dB) at 1 kHz. C611 provides a high frequency roll-off above 3 kHz.

The high pass filtered audio feeds three FET switches. The LP filter bypass switch Q605 feeds audio to the tone path for high frequency tone decoding (see the Tone Path description below). The Voice Mute switch Q602 allows muting the receiver audio only. This switched audio is summed with the signalling tone audio and feeds the 5-bit Digital to Analog Converter (DAC) on the Logic Board for volume setting beeps, alert tones, etc. Q603 allows muting both signalling tones and receiver audio. Each FET requires a logical high from the Logic Board microprocessor to turn on the audio switches. Note that Q603 feeds the inverting (-) input port of U603-B which is a "virtual" ground. Little or no audio signal will be measured on Q603 when Q603 is on.

U603-B provides the -6 dB/octave de-emphasized receiver response. At 1 kHz, the amplifier has a gain of 7 (17 dB) between Q602 and the RX AUDIO output. C617 and R619 determine the de-emphasis. R620 prevents U603-B from oscillating when driving capacitive loads. RX AUDIO feeds the System Board where the audio is attenuated before feeding the volume control and 3 Watt audio PA on the Control Board in the Front Cap Assembly.

TONE PATH

The tone path removes voice and noise signals from the unfiltered receiver audio (VOL-SQ HI) to provide the Logic Board microprocessor with limited tones and data. Transmitted Channel Guard tones and data, generated on the Logic Board, are low pass filtered to provide low distortion signals to the transmitter audio path.

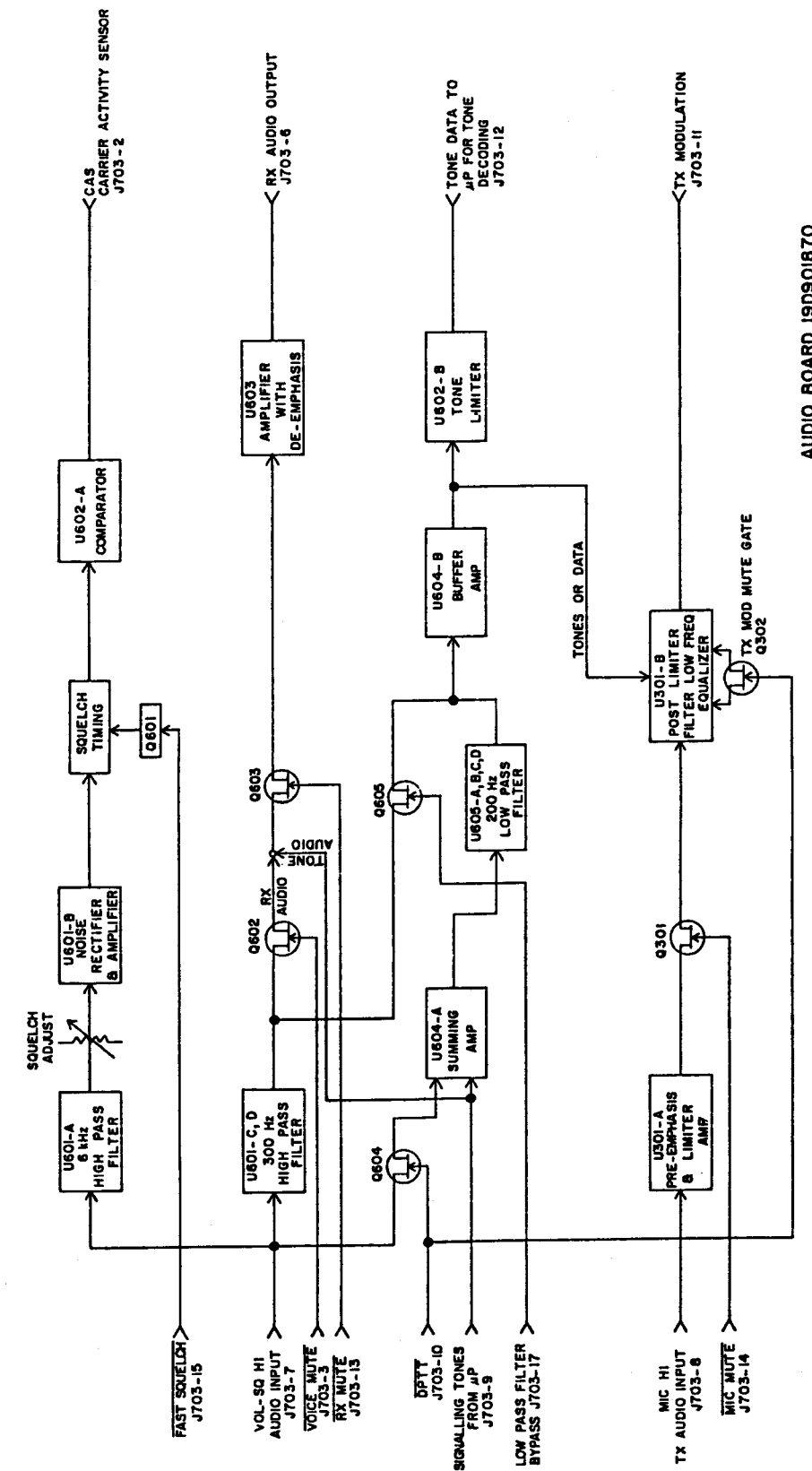

FIGURE 1 - OVERALL BLOCK DIAGRAM

## Receiving Tones:

VOL-SQ HI feeds FET switch Q604. In the receive mode,  $\overline{\text{DPTT}}$  is at a logical high which turns on Q604. Unfiltered receiver audio passes to summing amp U604-A. The summing amp provides a gain of 1 (0 dB) for the receiver audio. FET switch Q606 receives 10 ms pulses when the radio is in scan operation. The pulses occur when the microprocessor changes the scan channel frequency and detects carrier activity. Q606 momentarily turns on during the pulses to force the tone path to settle quickly for faster tone decoding.

Receiver audio from the summing amp feeds the 200 Hz low pass filter U605-A, B, C, and D to remove all voice signals and pass only the Channel Guard tones and data. U604-B buffers the high impedance output of the filter and provides 13 dB of gain. FET switch Q605 allows bypassing the 200 Hz low pass filter for high frequency tone decoding (Type -99 tones). When Q605 is turned on by a logic high on the LP FILTER BYPASS line, the low impedance output from the 300 Hz high pass filter dominates over the signal from the high impedance low pass filter.

The output of U604-B feeds the tone limiter U602-B. The tone limiter is a comparator with a 5 Vdc reference on the inverting (-) input provided by U604-B. R625-I and C627 remove the tone signals from the reference voltage. The non-inverting (+) input of U602-B receives the tone signals with the identical 5 Vdc reference voltage. The tone limiter provides a 5 Vp-p square wave to the TONE DATA line. This signal is routed to the Logic Board microprocessor where the software decodes the tone.

## Transmitting Tones:

In transmit mode,  $\overline{\text{DPTT}}$  is low which turns off Q604 to mute the receiver audio to the tone path. Channel Guard tones and data are digitally generated by the DAC on the Logic Board and feed the SIG TONE input line J703-9. Summing amp U604-A provides a gain of 0.1 (-20 dB) for the signalling tone input to reduce the 5 Vp-p Channel Guard signal to 0.5 V p-p.

The 200 Hz low pass filter (U605-A, B, C, and D) removes the high frequency harmonics from the digitally generated tones and data. U604-B provides 13 dB of gain for the filtered tones. The Channel Guard is summed into the transmitter audio path through R310. R310 fixes the Channel Guard level relative to the limited mic audio level.

## TRANSMITTER AUDIO PATH

The Audio Board provides all transmitter audio processing. The MIC HI input signal is amplified, pre-emphasized, limited, and low pass filtered. Processed mic audio and Channel Guard tones leave the Audio Board to feed the deviation adjust pot and the synthesizer VCO on the RF Board.

The microphone feeds the MIC HI input to the Audio Board. Series resistors R301 and R312 provide the supply voltage for the amplifier inside the microphone. Varying the resistor values will vary the microphone audio gain. A resistance of 180 ohms (obtained by shorting R312) will reduce the mic gain 8 dB. The MIC HI input level is nominally 30 mVrms at 1 kHz to produce 3 kHz deviation.

U301-A provides the 6 dB/octave pre-emphasis and amplitude limiting. C301, C304, and R302-A thru D provide the audio pre-emphasis. C303 controls the cut-off point for the high frequency pre-emphasis above 3 kHz. Voltage divider R302-G, H, I, and J provides the 4 volt operating reference bias for U301-A and the limiter reference voltages for D301-A and B. C302 filters audio and noise from the 4 volt bias. When the MIC input signal is at a level such that the output of U301-A does not exceed 4 Vp-p, the gain at 1 kHz is 30 dB at U301-A pin 1. When the audio level tries to exceed 4 Vp-p, diodes D301-A and B conduct on the negative and positive half cycles providing 100% negative feedback to reduce the gain of U301-A to 0.

The output of U301-A is fed through voltage divider R302-E and F. The divider and C307 provide one pole of RC filtering to FET switch Q301. This muting FET is controlled by the MIC MUTE line from the microprocessor. Here a logical high turns the gate on and a logical low mutes the mic audio. This gate allows muting the mic audio in the receive mode and when only tones are to be transmitted.

The switched mic audio feeds amplifier U301-B which performs several functions. C309, C311, R304, R305, and R306 form 2 additional poles for the post limiter filter, providing a total of 18 dB/octave filtering to the limited mic audio. U301-B also sums the Channel Guard tones and data into the transmit audio from the tone path. R310 determines the modulation level of the Channel Guard relative to the mic audio level. FET switch Q302 allows additional muting when in the receive mode and is controlled directly by the DPTT line from the processor. In receive mode, this line is high, turning

on Q302 which provides 100% negative feedback to reduce U301-B gain to 0. C310, C312, R307, R308, and R309 comprise a low frequency equalizer circuit for digital data transmission. The equalizer increases the gain 6 dB/octave below 15 Hz to help compensate for the low frequency roll-off normally experienced when modulating the VCO in RF synthesizers.

The output of U301-B is DC coupled to the TX MOD output. R311 prevents U301-B from oscillating when driving capacitive loads. TX MOD feeds the deviation pot and the synthesizer VCO on the RF Board.

## SUPPLY REGULATORS

The Audio Board receives 13 volts from the switched A+ filtered line on the Logic Board. This voltage feeds 8 volt regulator U606 and op amp U603. The regulator supplies 8 volts to all ICs except U603. U603-A supplies a low noise 5 volt bias to the audio circuits.

## SERVICE NOTES

Refer to the Block Diagrams, Figures 2 and 3, for proper signal levels and gains for the various audio paths.

Note the state of the FET switches for muting. These switches are controlled by the Logic Board. If a mute line is high (+5 V) you may ground that pin and monitor the results. However, if a mute line is low, the line may not be pulled high unless the line is disconnected from the Logic Board.

All bias points (+5 V) shown on the Audio Board schematic diagram are generated by U603-A. None of the operational amplifier circuits will operate properly without this voltage.

When measuring signal levels, remember that the inverting (-) input ports are "virtual grounds". No AC voltages will be present at these ports.



Ericsson GE Mobile Communications Inc.  
Mountain View Road • Lynchburg, Virginia 24502

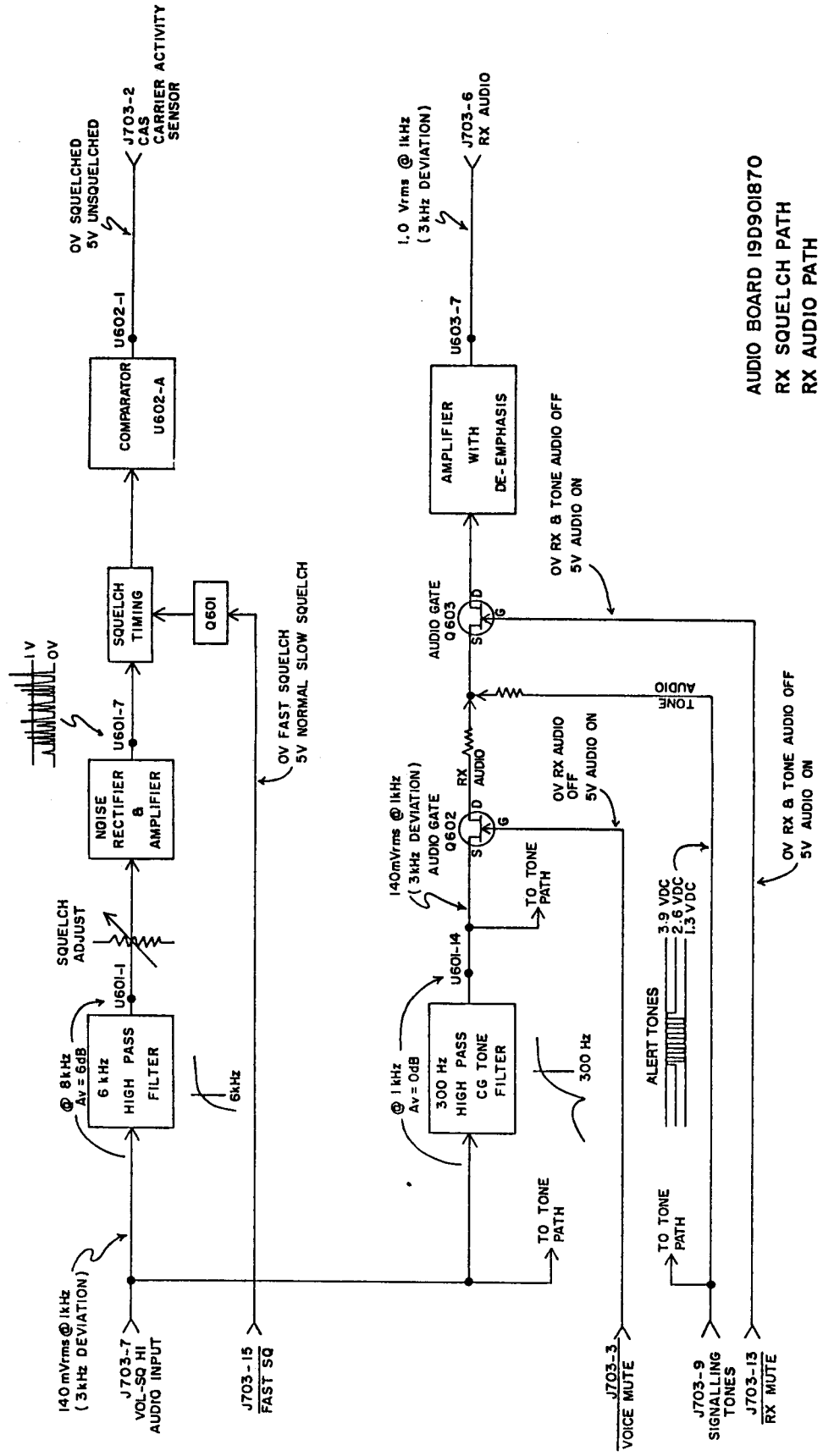

AUDIO BOARD 19D901870  
RX SQUELCH PATH  
RX AUDIO PATH

FIGURE 2 - SQUELCH PATH AND RX AUDIO PATH

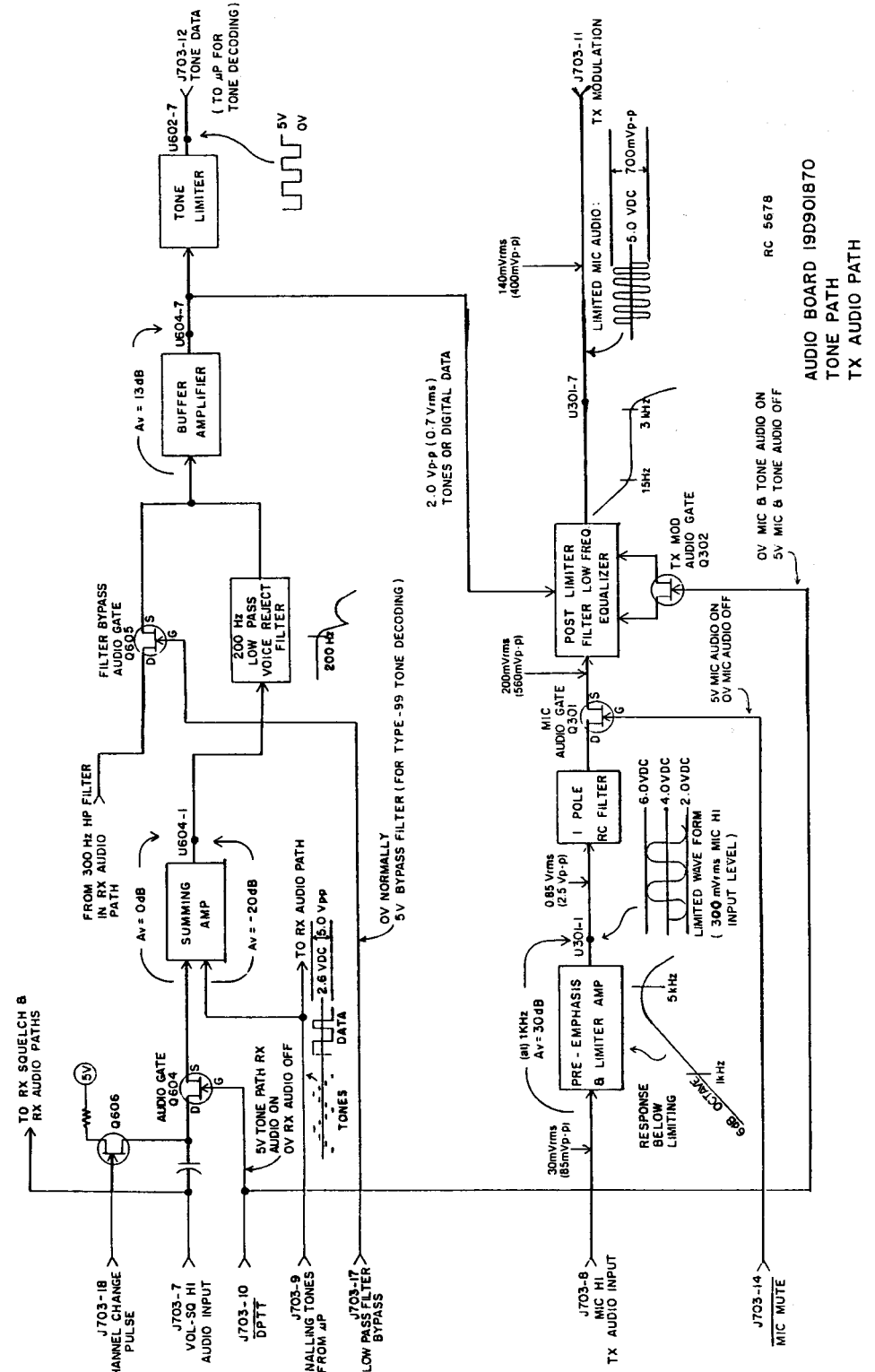

AUDIO BOARD 19D901870  
TONE PATH  
TX AUDIO PATH

FIGURE 3 - TONE PATH AND TRANSMITTER AUDIO PATH

COMPONENT SIDE

CHIP COMPONENT SIDE

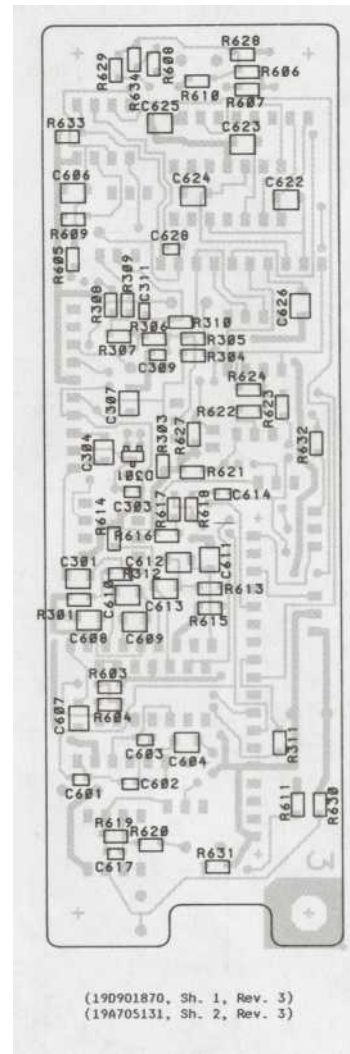
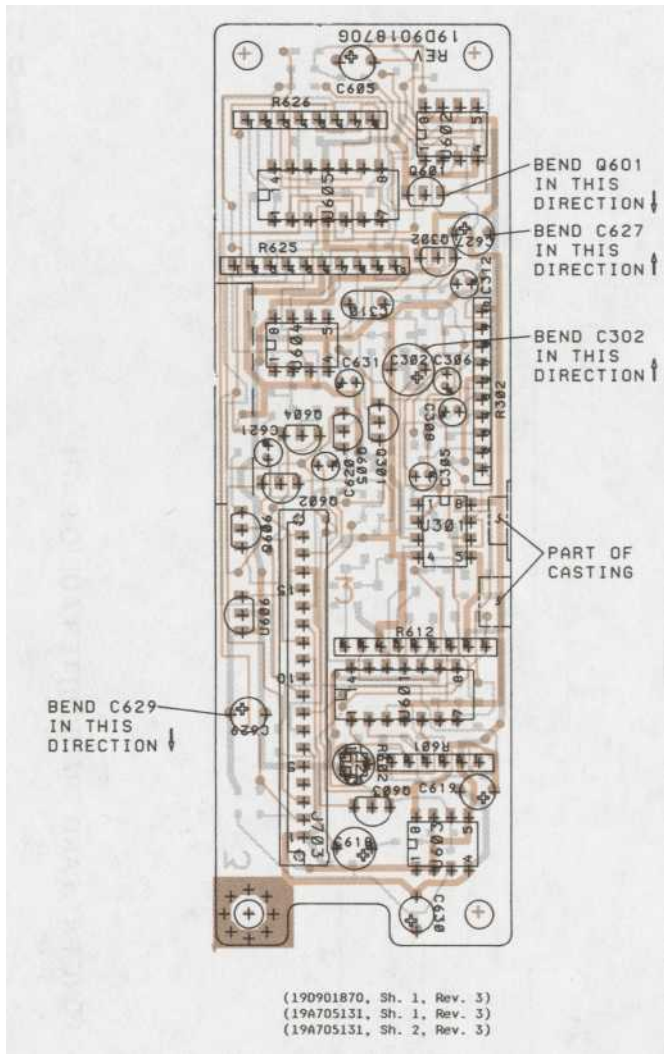

LEAD IDENTIFICATION  
FOR D301

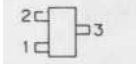

BACK SIDE OF BOARD

BOARD OUTLINE AND TAB LOCATION  
IS IDENTICAL TO 19D901696  
CHIEFTAIN AUDIO BIARD

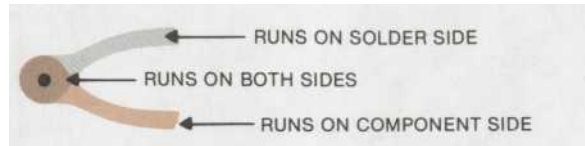

LEAD IDENTIFICATION  
FOR Q601

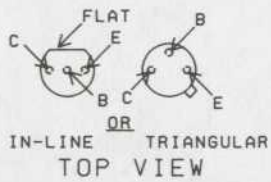

NOTE: LEAD ARRANGEMENT, AND NOT  
CASE SHAPE, IS DETERMINING  
FACTOR FOR LEAD IDENTIFICATION.

LEAD IDENTIFICATION  
FOR Q602-Q606,  
Q301 & Q302

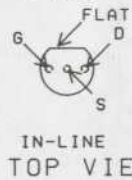

NOTE: CASE SHAPE IS DETERMINING  
FACTOR FOR LEAD IDENTIFICATION.

LEAD IDENTIFICATION  
FOR U606

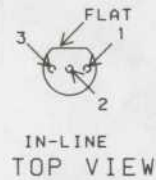

NOTE: CASE SHAPE IS DETERMINING  
FACTOR FOR LEAD IDENTIFICATION.

AUDIO BOARD  
19D901870G1

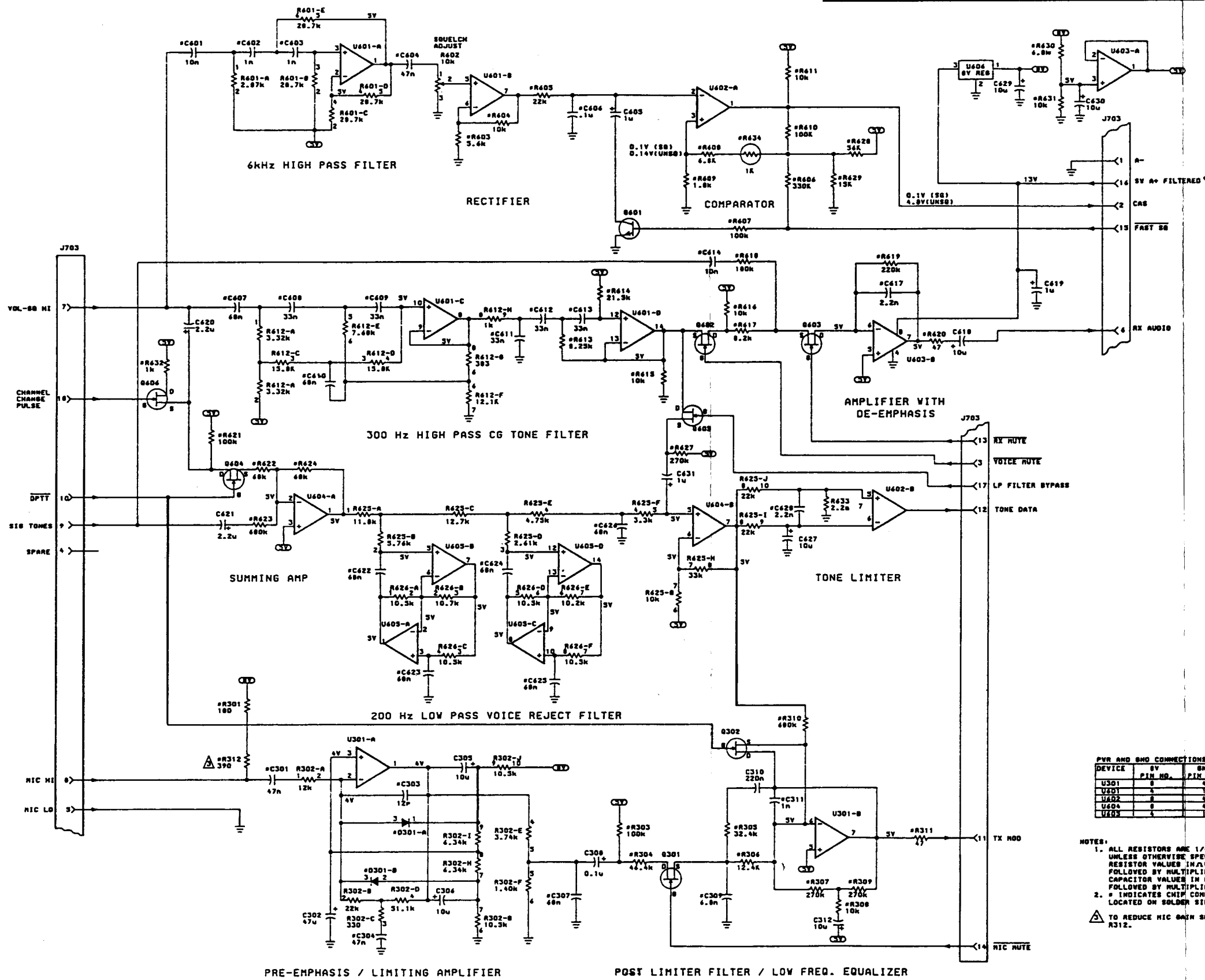

PVR AND SMD CONNECTIONS

DEVICE	SV	PIN NO.	SMD PIN NO.
U301	8	4	4
U301	8	11	11
U401	8	4	4
U401	8	11	11
U402	8	4	4
U402	8	11	11
U403	8	4	4
U403	8	11	11

MODEL NO.	REV. LETTER
19D901870G1	D

- NOTES:
- ALL RESISTORS ARE 1/4 WATT UNLESS OTHERWISE SPECIFIED. RESISTOR VALUES IN  $\mu$  UNLESS FOLLOWED BY MULTIPLIER K OR M. CAPACITOR VALUES IN F UNLESS FOLLOWED BY MULTIPLIER  $\mu$ , n, OR p. \*
  - \* INDICATES CHIP COMPONENT LOCATED ON SOLDER SIDE OF PWB.
- △ TO REDUCE NIC GAIN SHORT ACROSS R312.

MVS AUDIO BOARD  
19D901870G1  
ISSUE 3

SYMBOL	GE PART NO.	DESCRIPTION
----- CAPACITORS -----		
C301	19A702052P122	Ceramic: 0.047 uF ±5%, 50 VDCW.
C302	19A701534P9	Tantalum: 47 uF ±20%, 6.3 VDCW.
C303	19A702061P17	Ceramic: 12 pF ±5%, 50 VDCW, temp coef 0 ±30 PPM/°C.
C304	19A702052P122	Ceramic: 0.047 uF ±5%, 50 VDCW.
C305 and C306	19A704879P5	Electrolytic: 10 uF ±20%, 16 VDCW.
C307	19A702052P124	Ceramic: 0.068 uF ±5%, 50 VDCW.
C308	19A704879P13	Electrolytic: 0.1uF ±20%, 50 VDCW.
C309	19A702052P112	Ceramic: 6800 pF ±5%, 50 VDCW.
C310	162B3688P422K	Ceramic: 0.22 uF ±10%, 50 VDCW; sim to Erie 8131-M050-M5R-224K.
C311	19A702052P105	Ceramic: 1000 pF ±5%, 50 VDCW.
C312	19A704879P5	Electrolytic: 10 uF ±20%, 16 VDCW.
C601	19A702052P114	Ceramic: 0.01 uF ±5%, 50 VDCW.
C602 and C603	19A702052P105	Ceramic: 1000 pF ±5%, 50 VDCW.
C604	19A702052P22	Ceramic: 0.047 uF ±10%, 50 VDCW.
C605	19A701534P4	Tantalum: 1 uF ±20%, 35 VDCW.
C606	19A702052P26	Ceramic: 0.1 uF ±10%, 50 VDCW.
C607	19A702052P124	Ceramic: 0.068 uF ±5%, 50 VDCW.
C608 and C609	19A702052P120	Ceramic: 0.033 uF ±5%, 50 VDCW.
C610	19A702052P124	Ceramic: 0.068 uF ±5%, 50 VDCW.
C611 thru C613	19A702052P120	Ceramic: 0.033 uF ±5%, 50 VDCW.
C614	19A702052P14	Ceramic: 0.01 uF ±10%, 50 VDCW.
C617	19A702052P7	Ceramic: 2200 pF ±10%, 50 VDCW.
C618	19A701534P7	Tantalum: 10 uF ±20%, 16 VDCW.
C619	19A701534P4	Tantalum: 1 uF ±20%, 35 VDCW.
C620 and C621	19A704879P8	Electrolytic: 2.2uF ±20%, 50 VDCW.
C622 thru C626	19A702052P124	Ceramic: 0.068 uF ±5%, 50 VDCW.
C627	19A701534P7	Tantalum: 10 uF ±20%, 16 VDCW.
C628	19A702052P7	Ceramic: 2200 pF ±10%, 50 VDCW.
C629 and C630	19A701534P7	Tantalum: 10 uF ±20%, 16 VDCW.
C631	19A704879P9	Electrolytic: 1 uF ±20%, 50 VDCW.
----- DIODES -----		
D301	19A700053P2	Silicon: Fast Recovery: (2 diodes in series).
----- JACKS -----		
J703	19A704874P1	Connector: sim to Elco 00-9021-18-12-00-339.
----- TRANSISTORS -----		
Q301 and Q302	19A134137P7	N-type: PET.
Q601	19A700023P2	Silicon, NPN: sim to 2N3904.
Q602 thru Q606	19A134137P7	N-type: PET.

SYMBOL	GE PART NO.	DESCRIPTION
----- RESISTORS -----		
R301	19B800607P181	Metal film: 180 ohms ±5%, 1/8 w.
R302	19A704885P6	Resistor Network, Custom: 10 Pins, 1/8 w.
R303	19B800607P104	Metal film: 100K ohms ±5%, 1/8 w.
R304	19A702931P365	Metal film: 46.4K ohms ±1%, 1/8 w.
R305	19A702931P350	Metal film: 32.4K ohms ±1%, 1/8 w.
R306	19A702931P310	Metal film: 12.4K ohms ±1%, 1/8 w.
R307	19B800607P274	Metal film: 270K ohms ±5%, 1/8 w.
R308	19B800607P103	Metal film: 10K ohms ±5%, 1/8 w.
R309	19B800607P274	Metal film: 270K ohms ±5%, 1/8 w.
R310 *	19B800607P684	Metal film: 680K ohms ±5%, 1/8 w.
R311	19B800607P470	Metal film: 47 ohms ±5%, 1/8 w.
R312	19B800607P391	Metal film: 390 ohms ±5%, 1/8 w.
R601	19A704885P7	Resistor Network, Custom: 6 pins, 1/8 w.
R602	19B800779P10	Variable: 10K ohms ±25%, .3 watt.
R603	19B800607P562	Metal film: 5.6K ohms ±5%, 1/8 w.
R604	19B800607P103	Metal film: 10K ohms ±5%, 1/8 w.
R605	19B800607P223	Metal film: 22K ohms ±5%, 1/8 w.
R606 *	19B800607P334	Metal film: 330K ohms ±5%, 1/8 w.
R607	19B800607P104	Metal film: 100K ohms ±5%, 1/8 w.
R608 *	19B800607P682	Metal film: 6.8K ohms ±5%, 1/8 w.
R609	19B800607P182	Metal film: 1.8K ohms ±5%, 1/8 w.
R610 *	19B800607P104	Metal film: 100K ohms ±5%, 1/8 w.
R611	19B800607P103	Metal film: 10K ohms ±5%, 1/8 w.
R612	19A704885P8	Resistor Network, Custom: 9 pins, 1/8 w.
R613	19A702931P289	Metal film: 8250 ohms ±1%, 1/8 w.
R614	19A702931P333	Metal film: 21.5K ohms ±1%, 1/8 w.
R615 and R616	19B800607P103	Metal film: 10K ohms ±5%, 1/8 w.
R617	19B800607P822	Metal film: 8.2K ohms ±5%, 1/8 w.
R618	19B800607P184	Metal film: 180K ohms ±5%, 1/8 w.
R619	19B800607P224	Metal film: 220K ohms ±5%, 1/8 w.
R620	19B800607P470	Metal film: 47 ohms ±5%, 1/8 w.
R621	19B800607P104	Metal film: 100K ohms ±5%, 1/8 w.
R622	19B800607P683	Metal film: 68K ohms ±5%, 1/8 w.
R623	19B800607P684	Metal film: 680K ohms ±5%, 1/8 w.
R624	19B800607P683	Metal film: 68K ohms ±5%, 1/8 w.
R625	19A704885P9	Resistor Network, Custom: 10 pins, 1/8 w.
R626	19A704885P10	Resistor Network, Custom: 8 pins, 1/8 w.
R627	19B800607P274	Metal film: 270K ohms ±5%, 1/8 w.
R628 *	19B800607P563	Metal film: 56K ohms ±5%, 1/8 w.
R629 *	19B800607P153	Metal film: 15K ohms ±5%, 1/8 w.
R630 *	19B800607P682	Metal film: 6.8K ohms ±5%, 1/8 w.
R631	19B800607P103	Metal film: 10K ohms ±5%, 1/8 w.
R632	19B800607P102	Metal film: 1K ohms ±5%, 1/8 w.
R633 *	19B800607P225	Metal film: 2.2M ohms ±5%, 1/8 w.
R634 *	19A705813P1	Thermistor: sim to AL03006-624-73-G100.
----- INTEGRATED CIRCUITS -----		
U301	19A700086P4	Linear: Dual Op Amp; sim to 4558.
U601	19A701789P1	Linear: Quad Low Power Op Amp; sim to LM324N.
U602	19A134764P2	Linear: Dual Voltage Comparator; sim to LM393N.
U603 and U604	19A700086P4	Linear: Dual Op Amp; sim to 4558.
U605	19A701789P1	Linear: Quad Low Power Op Amp; sim to LM324N.
U606	19A704073P2	Linear: 8 Volt Regulator.

\*COMPONENTS ADDED, DELETED OR CHANGED BY PRODUCTION CHANGES

**PRODUCTION CHANGES**  
Changes in the equipment to improve performance or to simplify circuits are identified by a "Revision Letter", which is stamped after the model number of the unit. The revision stamped on the unit includes all previous revisions. Refer to the Parts List for the descriptions of parts affected by these revisions.

- REV. A - AUDIO BOARD 19D901870G1**  
To improve the Channel Guard deviation by 1.6db, changed R310 near Q302 from 820K to 680K ohms. Resistor R310 was: 19B800607P824 Metal film: 820K ohms ±5%, 1/8 w.
- REV. B - AUDIO BOARD 19D901870G1**  
To improve transmitter audio distortion and deviation specifications, changed R630 at U603-A pin 3 from 5.6K to 6.8K ohms. Resistor R630 was: 19B800607P562 Metal film: 5.6K ohms ±5%, 1/8 w.
- REV. C - AUDIO BOARD 19D901870G1**  
To improve operation by reducing Tone Limiter sensitivity, added R633 at U602-B pin 5. To improve operation by reducing transmitter alternator whine at low supply voltages, changed R301 supply connection from the +8 volt source to the +5 volt source. To reduce transmitter audio distortion, changed Q301 and R304 connections.
- REV. D - AUDIO BOARD 19D901870G1**  
To improve squelch operation over the operating temperature range, made the following circuit changes near squelch comparator U602-B: Added R634, deleted D601, and changed R606, R608, R610, R628 and R629. Earlier parts were:  
D601 19A700053P2 Silicon: Fast Recovery: (2 diodes in series).  
R606 19B800607P564 Metal film: 560K ±5%, 1/8 w.  
R608 19B800607P153 Metal film: 15K ±5%, 1/8 w.  
R610 19B800607P184 Metal film: 180K ±5%, 1/8 w.  
R628 19B800607P332 Metal film: 3.3K ±5%, 1/8 w.  
R629 19B800607P182 Metal film: 1.8K ±5%, 1/8 w.

**OPERATIONAL AMPLIFIER  
U601 & U605  
19A701789P1**

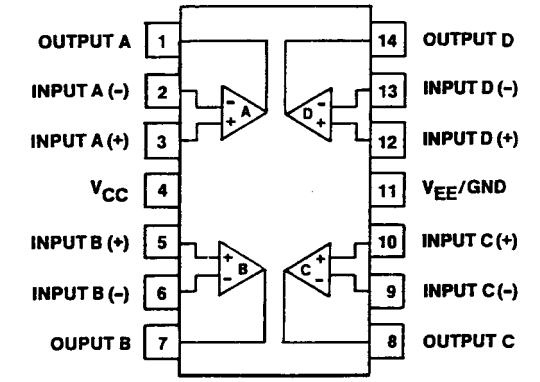

**IC DATA**

**OPERATIONAL AMPLIFIER  
U301, U603, & U604  
19A700086P4**

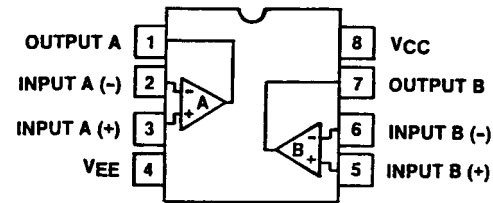

**LINEAR VOLTAGE COMPARTOR  
(U602)  
19A134764P2**

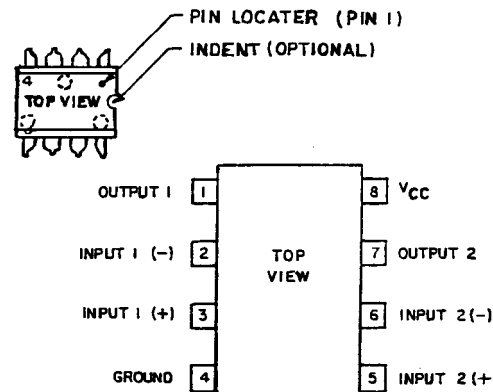

**VOLTAGE REGULATORS  
(U606)  
19A704073P2**

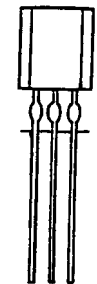

**BOTTOM VIEW**  
PIN 1 - OUTPUT  
PIN 2 - GROUND  
PIN 3 - INPUT