

ADDENDUM NUMBER 2 TO MAINTENANCE MANUAL

LBI-38673J

Refer to ECO#20043005

GENERAL

This addendum documents a change to the RX Front End Module (19D902782G3, G4, & G7) Maintenance Manual. Torque specification changed from 20 in-lbs. to 12.5 ± 2.50 in-lbs.

CHANGES

On page 6, update drawing 19D902782 with revision 10.

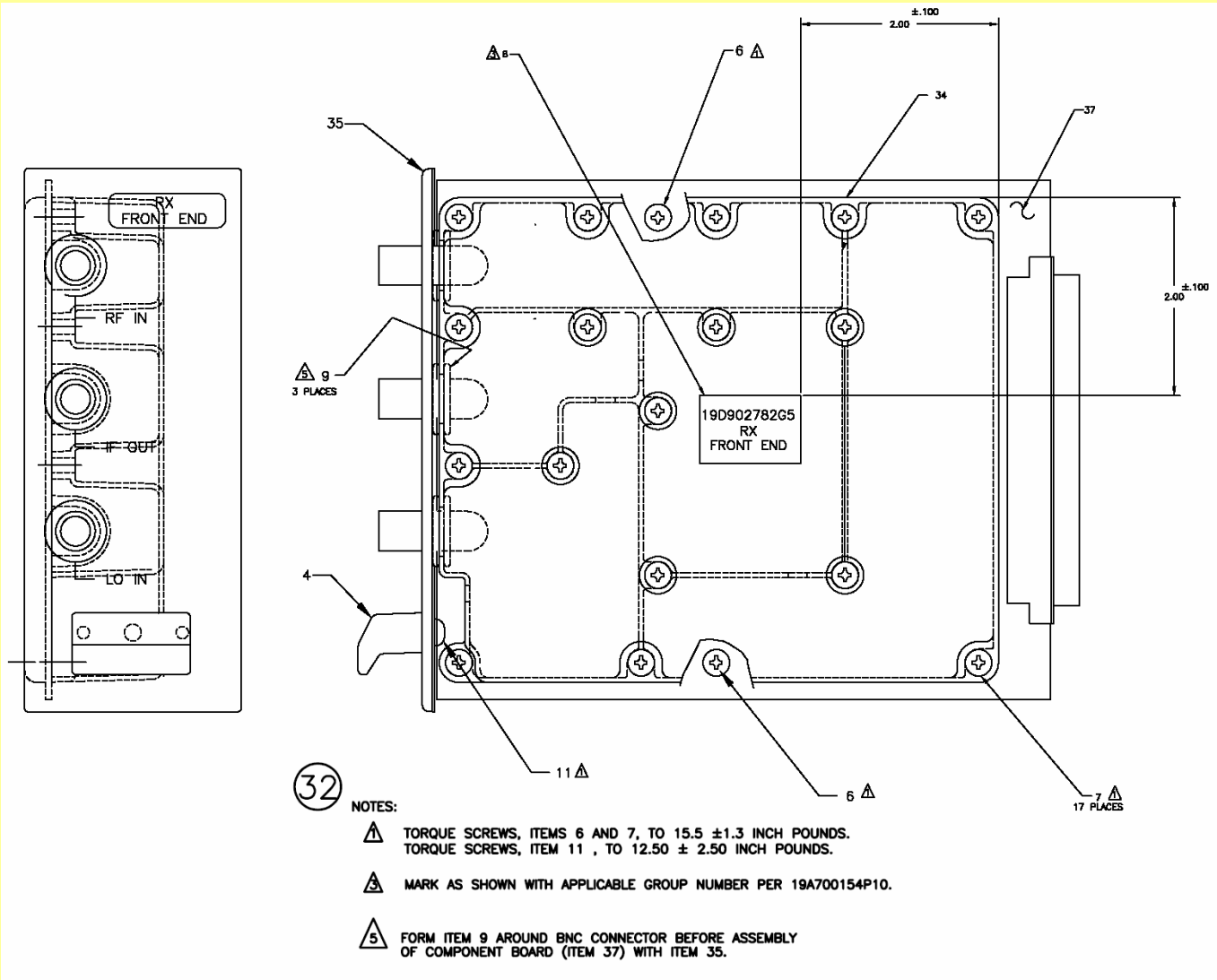

(19D902782, Rev. 10)

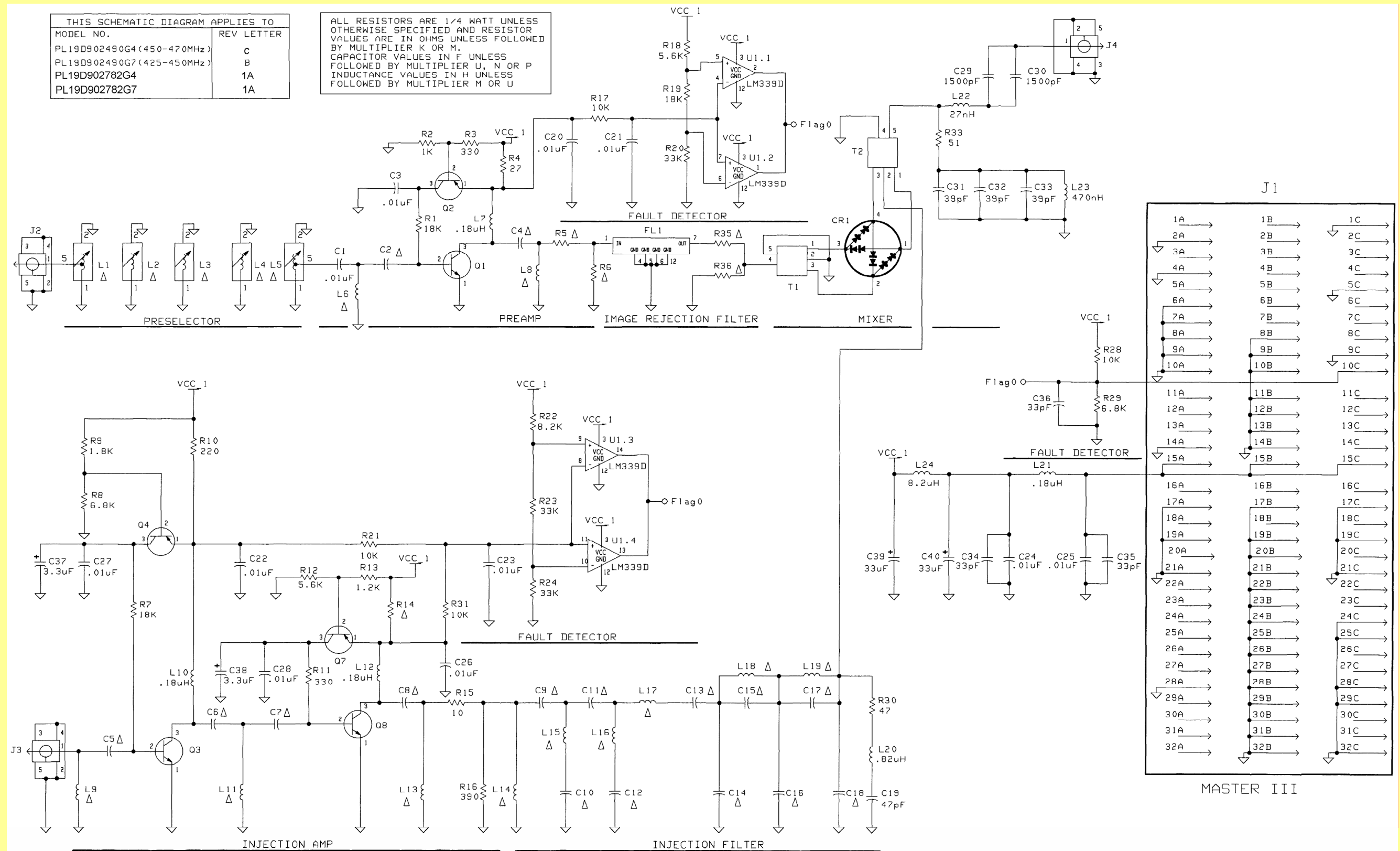

ADDENDUM NUMBER 1 TO MAINTENANCE MANUAL

LBI-38673J

Refer to ECO #20045023

COMPONENT	450-470 MHZ SPLIT (G450) Δ	450-470 MHZ SPLIT (G455) Δ	425-450 MHZ SPLIT (G425) Δ
C2	12pf	12pf	12pf
C4	8.2pf	8.2pf	100pf
C5	12pf	12pf	12pf
C6	82pf	82pf	100pf
C7	12pf	12pf	5.6pf
C8	22pf	22pf	120pf
C9	10pf	10pf	12pf
C10	6.8pf	6.8pf	15pf
C11	8.2pf	8.2pf	18pf
C12	10pf	10pf	15pf
C13	10pf	10pf	10pf
C14	3.9pf	3.9pf	3.3pf
C15	6.8pf	6.8pf	220pf
C16	3.9pf	3.9pf	3.3pf
C17	4.7pf	4.7pf	220pf
C18	3.9pf	3.9pf	3.3pf
FL1	HELICAL FILTER	HELICAL FILTER	HELICAL FILTER
L1	HELICAL COIL	HELICAL COIL	HELICAL COIL
L2	HELICAL COIL	HELICAL COIL	HELICAL COIL
L3	HELICAL COIL	HELICAL COIL	HELICAL COIL
L4	HELICAL COIL	HELICAL COIL	HELICAL COIL
L5	HELICAL COIL	HELICAL COIL	HELICAL COIL
L6	15nH	15nH	15nH
L8	33nH	33nH	33nH
L9	22nH	22nH	15nH
L11	12nH	12nH	22nH
L13	27nH	27nH	39nH
L14	18nH	18nH	10nH
L15	33nH	33nH	10nH
L16	22nH	22nH	12nH
L17	22nH	22nH	12nH
L18	10nH	10nH	15nH
L19	12nH	12nH	15nH
R5	10 OHMS	10 OHMS	0 OHMS
R6	390 OHMS	390 OHMS	NOT USED
R14	18 OHMS	10 OHMS	27 OHMS
R35	0 OHMS	0 OHMS	27 OHMS
R36	NOT USED	NOT USED	NOT USED

This page intentionally left blank

ADDENDUM NUMBER 1 TO MAINTENANCE MANUAL

LBI-38673J

Refer to ECO #20045023



GENERAL

This addendum adds a production change to Receiver Front End Module Maintenance Manual 19D902782G3, G4, and G7.

On page 4, add the following to the list of production changes:

REV. C – RECEIVER FRONT END BOARD 19D902490G4

To improve pass rate during conversion loss test and to replace obsolete part, inductor L19 was changed from 15mH inductor (19A705470P3) to a 12mH (19A705470P2) inductor.

Replace schematics 19D904768, Sh. 1, Rev. 7 on page 8 and 9 of the manual with revision 8 (see page 1 and 2).

**RECEIVER FRONT END MODULE
19D902782G3, G4, & G7**

TABLE OF CONTENTS

	<i>Page</i>
DESCRIPTION	Front Cover
SPECIFICATIONS	1
CIRCUIT ANALYSIS	
PRESELECTOR FILTER	1
PREAMPLIFIER	1
IMAGE REJECTION FILTER	1
INJECTION AMPLIFIER	1
INJECTION FILTER	1
DOUBLE BALANCE MIXER	1
FAULT DETECTOR	1
MAINTENANCE	
TEST PROCEDURE	2
ALIGNMENT PROCEDURE	2
TROUBLESHOOTING GUIDE	2
BLOCK DIAGRAM	1
PARTS LIST	3
PRODUCTION CHANGES	4
OUTLINE DIAGRAM	4
ASSEMBLY DIAGRAM	6
SCHEMATIC DIAGRAM	8

DESCRIPTION

The Receiver Front End (RXFE) Module amplifies and converts the RF signal to the first IF signal of 21.4 MHz. This is a down conversion process using low side (G3, G4) or high side (G7) injection. The RXFE module is powered by a regulated 12 volts. The RXFE printed wiring board contains the following functional circuits:

- Preselector Filter
- Preamplifier
- Image Rejection Filter
- Injection Amplifier
- Injection Filter
- Double Balanced Mixer
- Fault Detector

All but the Fault Detector circuit in the RXFE module have 50 ohm impedance terminations.

Table 1 - General Specifications

ITEM	SPECIFICATION
FREQUENCY RANGE	450.0 MHz - 470.0 MHz (G3, G4) 425.0 MHz - 450.0 MHz (G7)
IF FREQUENCY	21.4 MHz
3 dB BANDWIDTH	>3 MHz
IMPEDANCE	50 ohms at RF, LO, and IF Ports
CONVERSION LOSS	-2 dB \pm 1 dB
NOISE FIGURE (NF)	<7.5 dB
THIRD ORDER INTERCEPT POINT	>+20 dBm (G3, G4) >+15 dBm (G7)
IMAGE REJECTION	>100dB
INJECTION POWER	+2 dBm \pm 2 dB
TEMPERATURE RANGE	-30°C TO +60°C
SUPPLY VOLTAGE	12.0 Vdc
SUPPLY CURRENT	290 mA \pm 20 mA typical 230 mA \pm 20 mA typical (G3)

CIRCUIT ANALYSIS

PRESELECTION FILTER

The received RF signal (J2) is routed through the Preselector Filter. This filter provides front end selectivity and attenuates the potential spurious signals of first conversion. Typically, the filter has an insertion loss of 3 dB and an operational bandwidth of 2 MHz. The filter is primarily a five-pole helical bandpass filter (L1 thru L5) and is tunable in the band split (450.0 - 470.0 MHz or 425.0 - 450.0 MHz) range.

PREAMPLIFIER

The output from the Preselector is coupled through an impedance matching network consisting of L6, C2, and DC blocking capacitor C1 to the base of Preamplifier Q1. Q1 is a broadband common emitter amplifier. The Preamplifier stage is supplied by the regulated +12 Vdc line (VCC1) and draws about 70 mA through R4. It has a low noise figure and high Third Order Intercept point. Transistor Q2 provides Q1 with a constant voltage and current source. The bias on Q1 is moni-

tored by the Fault Detector circuit via R17. Capacitors C20 and C21 prevent the RF component from entering the fault circuit. The output signal is coupled to the Image Rejection Filter via an impedance matching network consisting of C4, L8, and resistors R5 and R6.

IMAGE REJECTION FILTER

Following the Preamplifier is the Image Rejection Filter. The Image Rejection Filter is a fixed tuned helical bandpass filter and can meet the desired image rejection of the frequency band.

INJECTION AMPLIFIER

The local oscillator input (J3) from the Receiver Synthesizer is coupled through an impedance matching network (C5 and L9) to the base of the Injection Amplifier Q3. Q3 and Q8 are common emitter amplifiers. The output from Q3 is coupled through an impedance matching network (C6, C7, and L11) to the base of Q8. The Injection Amplifier, consisting of Q3, Q8, and associated circuitry, is capable of amplifying the injection signal from 0 dBm to +25 dBm in the 428 to 449 MHz range

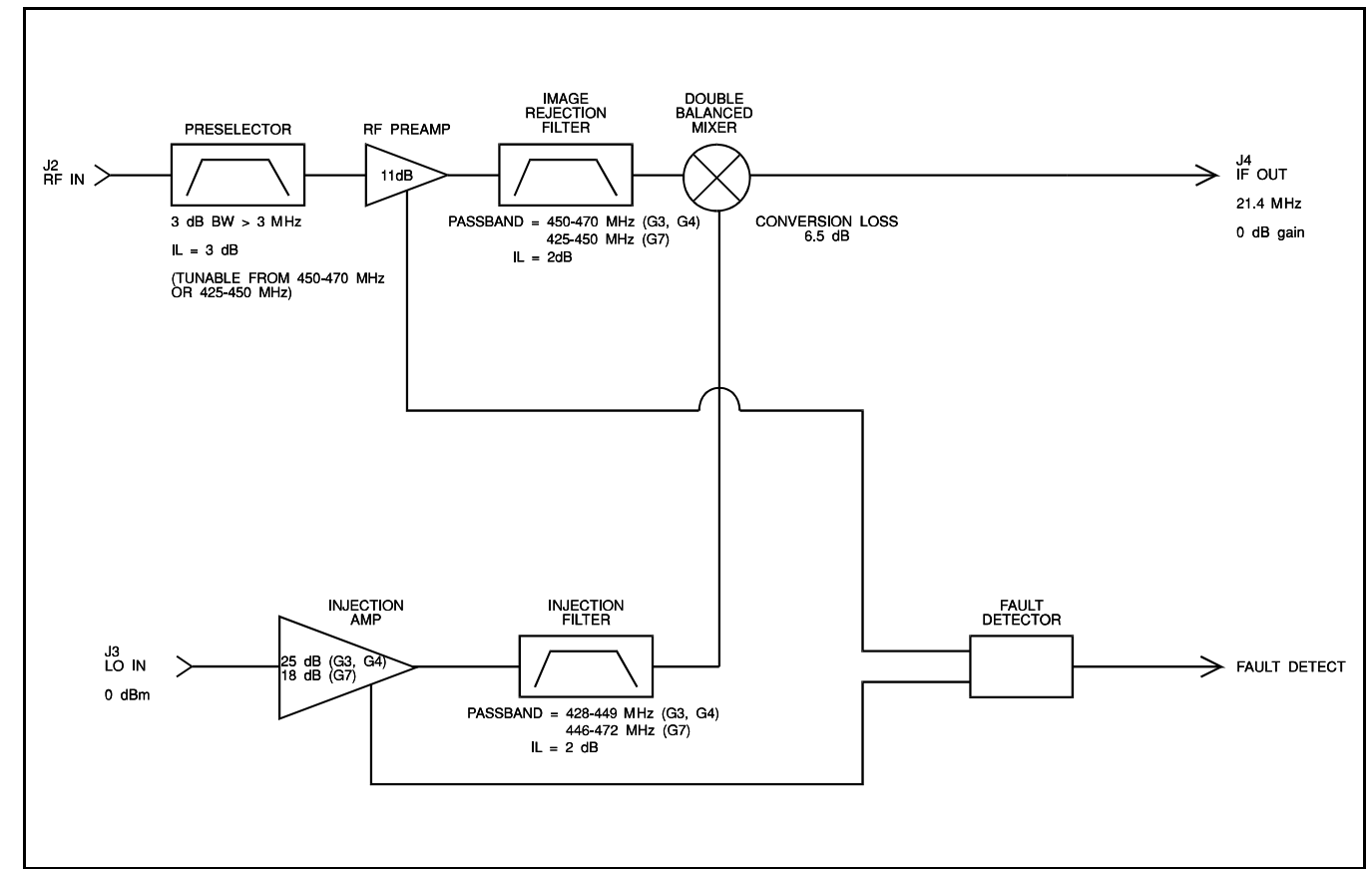

Figure 1 - Block Diagram

or to +18 dBm in the 446-472 MHz range. The amplifier is powered by the regulated +12 Vdc line (VCC1). Transistors Q4 and Q7 provide Q3 and Q8 with a constant voltage and current source. The bias on Q3 and Q8 is monitored by the Fault Detector circuit via R21 and R31, respectively. Capacitors C22, C23 and C26 prevent the RF component from entering the fault circuit. The output signal is coupled to the Injection Filter via an impedance matching network consisting of C8, L13, and resistors R15 and R16.

INJECTION FILTER

Following the Injection Amplifier is the Injection Filter consisting of C9 through C19, L14 through L20, and R30. Configured as a bandpass filter, the Injection Filter has a bandwidth of 428 to 450 MHz (G3, G4) or 446 to 472 MHz (G7) and is used to attenuate the harmonics of the Injection Amplifier. The filter also has an insertion loss of about 2 dB.

DOUBLE BALANCE MIXER

The Double Balance Mixer (DBM) is a broadband mixer. It converts an RF signal to the 21.4 MHz first conver-

sion IF frequency. The mixer uses low side (G3, G4) or high side (G7) injection driven by a local oscillator signal of +20 (G3, G4) or +15 (G7) dBm. The mixer conversion loss is typically about 6.5 dB. The IF output signal is then routed to the output connector (J4).

FAULT DETECTOR

The Fault Detector circuit monitors the operation of preamplifier and injection amplifier devices. Operational amplifiers U1.1 and U1.2 compare the bias on the Preamplifier Q1 to preset levels, while U1.3 and U1.4 compare the bias levels on Injection Amplifiers Q3 and Q8.

When the bias for Q1, Q3, and Q8 is within the preset window limits, the output from the comparators is a high level. This causes Q5 to conduct, turning off Q6 and the fault indicator, CR2. A high level signal is also sent to the Controller on the FLAG 0 line.

If the biasing for the amplifiers is not within the proper operating range, the fault detector circuit will pull the FLAG 0 line low. This turns off Q5 causing Q6 to conduct. Q6 now provides a ground path for CR2, turning on the fault indicator.

MAINTENANCE

TEST PROCEDURE

The RXFE module has to be tested for Noise Figure, Gain, Third Order Intercept Point, Isolation etc. With proper current drawing of devices, Bandwidth and Conversion Gain the RXFE module will meet its specifications. The following test procedures will verify proper Conversion Gain and current drain:

1. Supply 12 Vdc to pin 15A, B, C. (1C is ground.)
2. Inject the desired RF signal into RF IN at a level of -10 dBm.
3. Inject the desired local oscillator signal into LO IN at a level of 0 dBm [LO frequency = RF frequency - 21.4 MHz (G3, G4) + 21.4 MHz (G7)].
4. Measure the IF OUT power at 21.4 MHz, the ratio of RF IN to IF OUT is -2 dB ±1 dB.
5. Measure the current drawn by the RXFE module. Typical current drain is 290 mA.

ALIGNMENT PROCEDURE

Alignment for the Receiver Front End module consists of tuning the five-pole Preselector Filter only. Normally, the RXFE should only need the fine-tuning procedures. For a major receiver frequency change, the RXFE needs to be adjusted using the major-retuning procedures.

For Fine-Tuning

1. Supply 12 Vdc to pin 15A, B, C. (1C is ground.)
2. Inject the desired RF signal into RF IN (J2) at a level of -10 dBm.
3. Inject the desired local oscillator signal into LO IN (J3) at a level of 0 dBm [LO frequency = RF frequency - 21.4 MHz (G3, G4) + 21.4 MHz (G7)].
4. Detect IF signal at 21.4 MHz. Slightly adjust L1 to L5 to get maximum power (don't adjust more than

ten degrees). If an RF Voltmeter is used, connect a Low Pass Filter (LPF) to the IF OUT (J4) to attenuate high frequency components. The corner of the LPF should be set for 40 MHz.

5. Repeat Test Procedure steps to verify conversion gain and current drain.

For Major-Retuning

The best way to do a major retuning of the RXFE is with swept frequency tuning. The swept frequency tuning can be done using a Spectrum Analyzer and Tracking Generator. With proper Injection power and current drain, the frequency response of the Preselector Filter can be seen by viewing the RF to IF port feedthrough on the spectrum analyzer. This feedthrough is typically 35 dB down from the input level at the RF port. Use the following procedure for swept frequency tuning:

1. Supply 12 Vdc to pin 15A, B, C. (1C is ground.)
2. Inject the Tracking generator output at 0 dBm into the RF IN connector, (J2).
3. Inject local oscillator power at 0 dBm into the LO IN connector, (J3) [LO frequency = RF frequency - 21.4 MHz (G3, G4) + 21.4 MHz (G7)].
4. Preset the height of slugs with respect to the top of five-pole cavity as follows (Table 2):

Table 2

Frequency (MHz)	HEIGHT (in inches)				
	L1	L2	L3	L4	L5
450	15/64	16/64	17/64	17/64	16/64
454	16/64	17/64	17/64	18/64	15/64
458	16/64	19/64	19/64	19/64	17/64
462	18/64	19/64	20/64	20/64	18/64
466	21/64	22/64	23/64	21/64	20/64
470	22/64	24/64	24/64	23/64	22/64

5. Center the spectrum analyzer at the desired frequency and set the reference at about -30 dBm. Adjust L1 to L5 for best possible response.

TROUBLESHOOTING GUIDE

SYMPTOM	AREAS TO CHECK	READING (TYP.)
LOW CONVERSION GAIN	Check Vcc	12 V
	Preselector Loss	3.5 dB
	Preamplifier Gain	11 dB
	Image Rej. Filter Loss	2 dB
	1st Mixer Conversion Loss	6.5 dB
	1 L.O. Level (@ mixer L.O. port)	+22 ±2 dBm (G3, G4) +14 ±2 dBm (G7)
LED INDICATOR ON	Check Vc of Q1	10 V
	Check Vc of Q3 and Q8	10 V
IF FREQUENCY OFF	Check L.O. FREQUENCY	L.O. frequency = RF frequency - 21.4 MHz (G3,G4) + 21.4 MHz (G7)
LOW L.O. POWER*	Injection Amplifier Gain	23 ±2 dB (G3, G4) 18 ±2 dB (G7)
	Injection Filter Loss	2 dB

* NOTE: For troubleshooting the gain or loss, the RXFE needs to be under the normal operating condition:

- 12 Vdc supply.
- Inject L.O. power at a level of 0 dBm into LO IN (J3), [LO freq. = RF freq. - 21.4 MHz (G3, G4) + 21.4 MHz (G7).
- Inject the desired RF signal at a level of -10 dBm into RF IN (J2).
- Terminate the IF OUT (J4) with a good 50 ohm impedance.
- Use a Spectrum Analyzer and 50 ohm probe (with good RF grounding) to probe at the input and output of each stage to check its gain or loss (see schematic diagram).

PARTS LIST

LBI-38673J

RECEIVER FRONT END MODULE
 19D902782G3 (450-470 MHz)
 19D902782G4 (450-470 MHz ETSI)
 19D902782G7 (425-450 MHz)
 ISSUE 5

SYMBOL	PART NUMBER	DESCRIPTION
4	19D902555P1	Handle.
5	19D902534P1	Cover, RF.
6	19A702381P506	Screw, thread forming: TORX, No. M3.5-.6 x 6.
7	19A702381P513	Screw, thread forming: TORX, No. M3.5-0.6 X 13.
11	19A702381P508	Screw, thd. form: No. 3.5-0.6 x 8.
RECEIVER FRONT END BOARD 19D902490G3 (450-470 MHz) 19D902490G4 (450-470 MHz ETSI) 19D902490G7 (425-450 MHz)		
----- CAPACITORS -----		
C1	19A702052P14	Ceramic: 0.01 μ F \pm 10%, 50 VDCW.
C2	19A702061P17	Ceramic: 12 pF \pm 5%, 50 VDCW, temp coef 0 \pm 30 PPM.
C3	19A702052P14	Ceramic: 0.01 μ F \pm 10%, 50 VDCW.
C4	19A702061P12	Ceramic: 8.2 pF \pm 0.5 pF, 50 VDCW, temp coef 0 \pm 60 PPM. (Used in G3, G4).
C4	19A702061P61	Ceramic: 100pF, \pm 5%, 50VDCW, temp coef 0 \pm 30 PPM/ $^{\circ}$ C. (Used in G7).
C5	19A702061P17	Ceramic: 12 pF \pm 5%, 50 VDCW, temp coef 0 \pm 30 PPM.
C6	19A702061P57	Ceramic: 82 pF \pm 5%, 50 VDCW, temp coef 0 \pm 30 PPM. (Used in G3, G4).
C6	19A702061P63	Ceramic: 120 pF, \pm 5%, 50VDCW, temp coef 0 \pm 30 PPM/ $^{\circ}$ C. (Used in G7).
C7	19A702061P17	Ceramic: 12 pF \pm 5%, 50 VDCW, temp coef 0 \pm 30 PPM. (Used in G3, G4).
C7	19A702061P10	Ceramic: 5.6 pF, 0.5 pF, 50VDCW, temp coef 0 \pm 60 PPM/ $^{\circ}$ C. (Used in G7).
C8	19A702061P29	Ceramic: 22 pF \pm 5%, 50 VDCW, temp coef 0 \pm 30 PPM. (Used in G3, G4).
C8	19A702061P63	Ceramic: 120 pF, \pm 5%, 50VDCW, temp coef 0 \pm 30 PPM. (Used in G7).
C9	19A702061P13	Ceramic: 10 pF \pm 5%, 50 VDCW, temp coef 0 \pm 30 PPM. (Used in G3, G4).
C9	19A702061P17	Ceramic: 12 pF, \pm 5%, 50VDCW, temp coef 0 \pm 30 PPM. (Used in G7).
C10	19A702061P11	Ceramic: 6.8 pF \pm 0.5 pF, 50 VDCW, temp coef 0 \pm 60 PPM. (Used in G3, G4).
C10	19A702061P21	Ceramic: 15 pF, \pm 5%, 50VDCW, temp coef 0 \pm 30 PPM. (Used in G7).
C11	19A702061P12	Ceramic: 8.2 pF \pm 0.5 pF, 50 VDCW, temp coef 0 \pm 60 PPM. (Used in G3, G4).
C11	19A702061P25	Ceramic: 18 pF, \pm 5%, 50VDCW, temp coef 0 \pm 30 PPM. (Used in G7).
C12	19A702061P13	Ceramic: 10 pF \pm 5%, 50 VDCW, temp coef 0 \pm 30 PPM. (Used in G3, G4).
C12	19A702061P21	Ceramic: 15 pF, \pm 5%, 50VDCW,

* COMPONENTS, ADDED, DELETED OR CHANGED BY PRODUCTION CHANGES

SYMBOL	PART NUMBER	DESCRIPTION
C13	19A702061P13	Ceramic: 10 pF, \pm 5%, 50VDCW, temp coef 0 \pm 30 PPM.
C14	19A702061P8	Ceramic: 3.9 pF \pm 0.5 pF, 50 VDCW, temp coef 0 \pm 120 PPM. (Used in G3, G4).
C14	19A702061P7	Ceramic: 3.3 pF, 0.5 pF, 50VDCW, temp coef 0 \pm 120 PPM. (Used in G7).
C15	19A702061P11	Ceramic: 6.8 pF \pm 0.5 pF, 50 VDCW, temp coef 0 \pm 60 PPM. (Used in G3, G4).
C15	19A702061P69	Ceramic: 220 pF, \pm 5%, 50VDCW, temp coef 0 \pm 30 PPM. (Used in G7).
C16	19A702061P8	Ceramic: 3.9 pF \pm 0.5 pF, 50 VDCW, temp coef 0 \pm 120 PPM. (Used in G3, G4).
C16	19A702061P7	Ceramic: 3.3 pF, 0.5 pF, 50VDCW, temp coef 0 \pm 120 PPM. (Used in G7).
C17	19A702061P9	Ceramic: 4.7 pF \pm 0.5 pF, 50 VDCW, temp coef 0 \pm 60 PPM. (Used in G3, G4).
C17	19A702061P69	Ceramic: 220 pF, \pm 5%, 50VDCW, temp coef 0 \pm 30 PPM. (Used in G7).
C18	19A702061P8	Ceramic: 3.9 pF \pm 0.5 pF, 50 VDCW, temp coef 0 \pm 120 PPM. (Used in G3, G4).
C18	19A702061P7	Ceramic: 3.3 pF, 0.5 pF, 50VDCW, temp coef 0 \pm 30 PPM. (Used in G7).
C19	19A702061P45	Ceramic: 47 pF \pm 5%, 50 VDCW, temp coef 0 \pm 30 PPM.
C20	19A702052P14	Ceramic: 0.01 μ F \pm 10%, 50 VDCW.
C29	19A702061P89	Ceramic: 1500 pF, \pm 5%, 50VDCW, temp coef 0 \pm 30 PPM. (Used in G4 & G7).
*C29	19A705205P26	Tantalum: 3.3 μ F \pm 20%, 16VDCW, (Used in G3).
*C31	19A705205P15	Tantalum: 33 μ F \pm 20%, 16VDCW, (Used in G3).
C31	19A702236P40	Ceramic: 39 pF, \pm 5%, 50VDCW, temp coef 0 \pm 30 PPM. (Used in G4 & G7).
C34	19A702061P37	Ceramic: 33 pF, \pm 5%, 50VDCW, temp coef 0 \pm 30 PPM. (Used in G4 & G7).
*C37	19A705205P26	Tantalum: 3.3 μ F \pm 20%, 16VDCW, (Used in G4, G7).
*C39	19A705205P15	Tantalum: 33 μ F \pm 20%, 16VDCW, (Used in G4, G7).
*C40		
----- DIODES -----		
CR1	344A3062P1	Diode, Schottky (part of 19D902782G3).
CR2	19A703595P10	Diode, Optoelectric: Red; sim to HP HLMP-1301-010. (Used in G3).
----- FILTERS -----		
FL1	19A705458P1	Helical, UHF: 450-470 MHz. (Used in G3, G4).
FL1	19A705458P5	Helical, UHF: 425-450 MHz. (Used in G7).

SYMBOL	PART NUMBER	DESCRIPTION
----- JACKS -----		
J1	19B801587P7	Connector, DIN: 96 male contacts, right angle mounting; sim to AMP 650887-1.
J2	19A115938P24	Connector, receptacle.
J4		
----- INDUCTORS -----		
L1	19C850817P10RF	Coil: sim to Paul Smith SK853-1. (Used in G3, G4).
L1	19C850817P25	Coil. (Used in G7).
L2	19C850817P9	RF Coil: sim to Paul Smith SK853-1. (Used in G3, G4).
L2	19C850817P5	Coil. (Used in G7).
L5	19C850817P10	RF Coil: sim to Paul Smith SK853-1. (Used in G3, G4).
L5	19C850817P25	Coil. (Used in G7).
L6	19A705470P3	Coil, Fixed: 15 nH; sim to Toko 380NB-15nM.
L7	19A705470P16	Coil, Fixed: 0.18 μ H; sim to Toko 380NB-R18M.
L8	19A705470P7	Coil, fixed: 33 nH \pm 20%; sim to Toko 380NB-33nM.
L9	19A705470P5	Coil, Fixed: 22 nH; sim to Toko 380NB-22nM. (Used in G3, G4).
L9	19A705470P3	Coil, fixed: 15 nH; sim to Toko 380NB-15nM. (Used in G7).
L10	19A705470P16	Coil, Fixed: 0.18 μ H; sim to Toko 380NB-R18M.
L11	19A705470P3	Coil, Fixed: 15 nH; sim to Toko 380NB-15nM. (Used in G3, G4).
L11	19A705470P5	Coil, fixed: 22 nH; sim to Toko 380NB-22nM. (Used in G7).
L12	19A705470P16	Coil, Fixed: 0.18 μ H; sim to Toko 380NB-R18M.
L13	19A705470P6	Coil, Fixed: 27 nH; sim to Toko 380NB-27nM. (Used in G3, G4).
L13	19A705470P8	Coil, fixed: 39 nH; sim to Toko 380NB-35nM. (Used in G7).
L14	19A705470P4	Coil, Fixed: 18 nH; sim to Toko 380NB-18nM. (Used in G3, G4).
L15	19A705470P7	Coil, fixed: 33 nH \pm 20%; sim to Toko 380NB-33nM. (Used in G3, G4).
L14	19A705470P1	Coil, fixed: 10 nH; sim to Toko 380NB-10nM. (Used in G7).
L16	19A705470P5	Coil, Fixed: 22 nH; sim to Toko 380NB-22nM. (Used in G3, G4).
L16	19A705470P2	Coil, fixed: 12 nH; sim to Toko 380NB-12 nM. (Used in G7).
L18	19A705470P1	Coil, Fixed: 10 nH; sim to Toko 380NB-10nM. (Used in G3, G4).
L18	19A705470P3	Coil, fixed: 15 nH; sim to Toko 380NB-15nM. (Used in G7).
L19	19A705470P3	Coil, fixed: 15 nH; sim to Toko 380NB-15nM.
L20	19A705470P24	Coil, Fixed: 0.82 μ H; sim to Toko 380NB-R82M.

SYMBOL	PART NUMBER	DESCRIPTION
L21	19A705470P16	Coil, Fixed: 0.18 μ H; sim to Toko 380NB-R18M.
L22	19A700021P105	Coil, RF ceramic: 22 nH. (Used in G4).
L22	19A705470P6	Coil, fixed: 27 nH; sim to Toko 380NB-27nM. (Used in G7).
L23	19A700021P13	Coil, RF ceramic: 470 nH. (Used in G4).
L23	19A705470P21	Coil, fixed: 0.47 μ H; sim to Toko 380NB-R47M. (Used in G7).
*L24	19A700000P122	Coil, fixed: 8.2 μ H \pm 10%; sim to Jeffers 22-8.2-10.
----- TRANSISTORS -----		
Q1	344A3058P1	Silicon, NPN.
Q2	19A700059P2	Silicon, PNP: sim to MMBT3906, low profile.
Q3	19A704708P3	Silicon NPN.
Q4	19A700059P2	Silicon, PNP: sim to MMBT3906, low profile.
Q5	19A700076P2	Silicon, NPN: sim to MMBT3904, low profile. (Used in G3).
Q6		
Q7	19A700059P2	Silicon, PNP: sim to MMBT3906, low profile.
Q8	344A3058P1	Silicon, NPN.
----- RESISTORS -----		
R1	19B800607P183	Metal film: 18K ohms \pm 5%, 1/8 w.
R2	19B800607P102	Metal film: 1K ohms \pm 5%, 1/8 w.
R3	19B800607P331	Metal film: 330 ohms \pm 5%, 1/8 w.
R4	19B800607P270	Metal film: 27 ohms \pm 5%, 1/8 w.
R5	19B800607P100	Metal film: 10 ohms \pm 5%, 1/8 w. (Used in G3, G4).
R5	19B800607P1	Metal film: 0 ohms. (Used in G7).
R6	19B800607P391	Metal film: 390 ohms \pm 5%, 1/8 w. (Used in G3, G4).
R7	19B800607P183	Metal film: 18K ohms \pm 5%, 1/8 w.
R8	19B800607P682	Metal film: 6.8K ohms \pm 5%, 1/8 w.
R9	19B800607P182	Metal film: 1.8K ohms \pm 5%, 1/8 w.
R10	19B800607P470	Metal film: 47 ohms \pm 5%, 1/8 w. (Used in G3).
R10	19B800607P221	Metal film: 220 ohms \pm 5%, 1/8w. (Used in G4).
R11	19B800607P331	Metal film: 330 ohms \pm 5%, 1/8 w.
R12	19B800607P562	Metal film: 5.6K ohms \pm 5%, 1/8 w.
R13	19B800607P122	Metal film: 1.2K ohms \pm 5%, 1/8 w.
R14	19B800607P180	Metal film: 18 ohms \pm 5%, 1/8 w. (Used in G3, G4).
R14	19B800607P270	Metal film: 27 ohms \pm 5%, 1/8 w. (Used in G7).
R15	19B800607P270	Metal film: 27 ohms \pm 5%, 1/8 w. (Used in G3 & G7).
R15	19B800607P100	Metal film: 10 ohms \pm 5%, 1/8 w. (Used in G4).
R16	19B800607P181	Metal film: 180 ohms \pm 5%, 1/8 w. (Used in G3 & G7).
R16	19B800607P391	Metal film: 390 ohms \pm 5%, 1/8 w. (Used in G4).
R17	19B800607P103	Metal film: 10K ohms \pm 5%, 1/8 w.

SYMBOL	PART NUMBER	DESCRIPTION
R18	19B800607P562	Metal film: 5.6K ohms ±5%, 1/8 w.
R19	19B800607P183	Metal film: 18K ohms ±5%, 1/8 w.
R20	19B800607P333	Metal film: 33K ohms ±5%, 1/8 w.
R21	19B800607P103	Metal film: 10K ohms ±5%, 1/8 w.
R22	19B800607P822	Metal film: 8.2K ohms ±5%, 1/8 w.
R23 and R24	19B800607P333	Metal film: 33K ohms ±5%, 1/8 w.
R25	19B800607P104	Metal film: 100K ohms ±5%, 1/8 w. (Used in G3).
R26	19B800607P273	Metal film: 27K ohms ±5%, 1/8 w. (Used in G3).
R27	19B800607P391	Metal film: 390 ohms ±5%, 1/8 w. (Used in G3).
R28	19B800607P103	Metal film: 10K ohms ±5%, 1/8 w.
R29	19B800607P682	Metal film: 6.8K ohms ±5%, 1/8 w.
R30	19B800607P470	Metal film: 47 ohms ±5%, 1/8 w.
R31	19B800607P103	Metal film: 10K ohm, ±5%, 1/8w.
R32	19B800607P560	Metal film: 56 ohms, ±5%, 1/8w.
R33	19B800607P510	Metal film: 51 ohms, ±5%, 1/8w. (Used in G7).
R34	19B801251P1	Metal film: 0 ohms.
R35	19B800607P270	Metal film: 27 ohms, ±5%, 1/8w. (Used in G7).
----- TRANSFORMERS -----		
T1 and T2	344A3063P1	Transformer.
----- INTEGRATED CIRCUITS -----		
U1	19A704125P1	Linear: Quad Comparator; sim to LM339D.
----- MISCELLANEOUS -----		
20	19B800701P2	Tuning screw.
21	19A701800P1	Stop nut.
22	19D902467P2	Casting.
28	19D902534P2	Cover, RF. (Used in G4).
29	19D904572P1	Cover, Gasket. (Used in G4).
30	19B802690P1	Grommet. (Used in G4).

PRODUCTION CHANGES

Changes in the equipment to improve or to simplify circuits are identified by a "Revision Letter", which is stamped after the model number of the unit. The revision stamped on the unit includes all previous revisions. Refer to the Parts List for descriptions of parts affected by these revisions.

REV. A - RECEIVER FRONT END BOARD 19D902490G3
Upgrade to ETSI specs. New PWB.

REV. B - RECEIVER FRONT END BOARD 19D902490G3

REV. A - RECEIVER FRONT END BOARD 19D902490G4
To correct overheating problem.
R14 was 10 ohms (19B800607P100).

REV. C - RECEIVER FRONT END BOARD 19D902490G3
To eliminate receiver spurious response at 100 kHz switching power supply frequency.
Added C29, C30, C31, C32 and L24.

PRODUCTION CHANGES - CONT.

REV. B - RECEIVER FRONT END BOARD 19D902490G4
REV. A - RECEIVER FRONT END BOARD 19D902490G7
To eliminate receiver spurious response at 100 kHz switching power supply frequency.
Added C37, C38, C39, C40 and L24.

REV. B - RECEIVER FRONT END BOARD 19D902490G7
To improve receiver sensitivity L8 changed from 18nH (19A705470P4) to 33nH (19A705470P7); R5 changed from 10 ohms (19B800607P100) to 0 ohms (19B800607P1); R14 changed from 18 ohms (19B800607P180) to 27 ohms (19B800607P270); R6 (19B800607P391) and R36 (19B800607P391) were deleted.

REV. D - RECEIVER FRONT END BOARD 19D902490G3
Reduce excessive LO drive level. Changed R15 from 10 ohms (19B800607P100) to 27 ohms (19B800607P270). Changed R16 from 390 ohms (19B800607P391) to 180 ohms (19B800607P181).

Rev. 1A - Receiver Front End Module 19D902782G4 & G7
To reduce RF emissions, the conductive connector grommet was replaced with a thicker part to ensure contact with the front panel at RF connectors. RF Shielding Grommet was changed from 19B802690P1 to 19D802690P2.

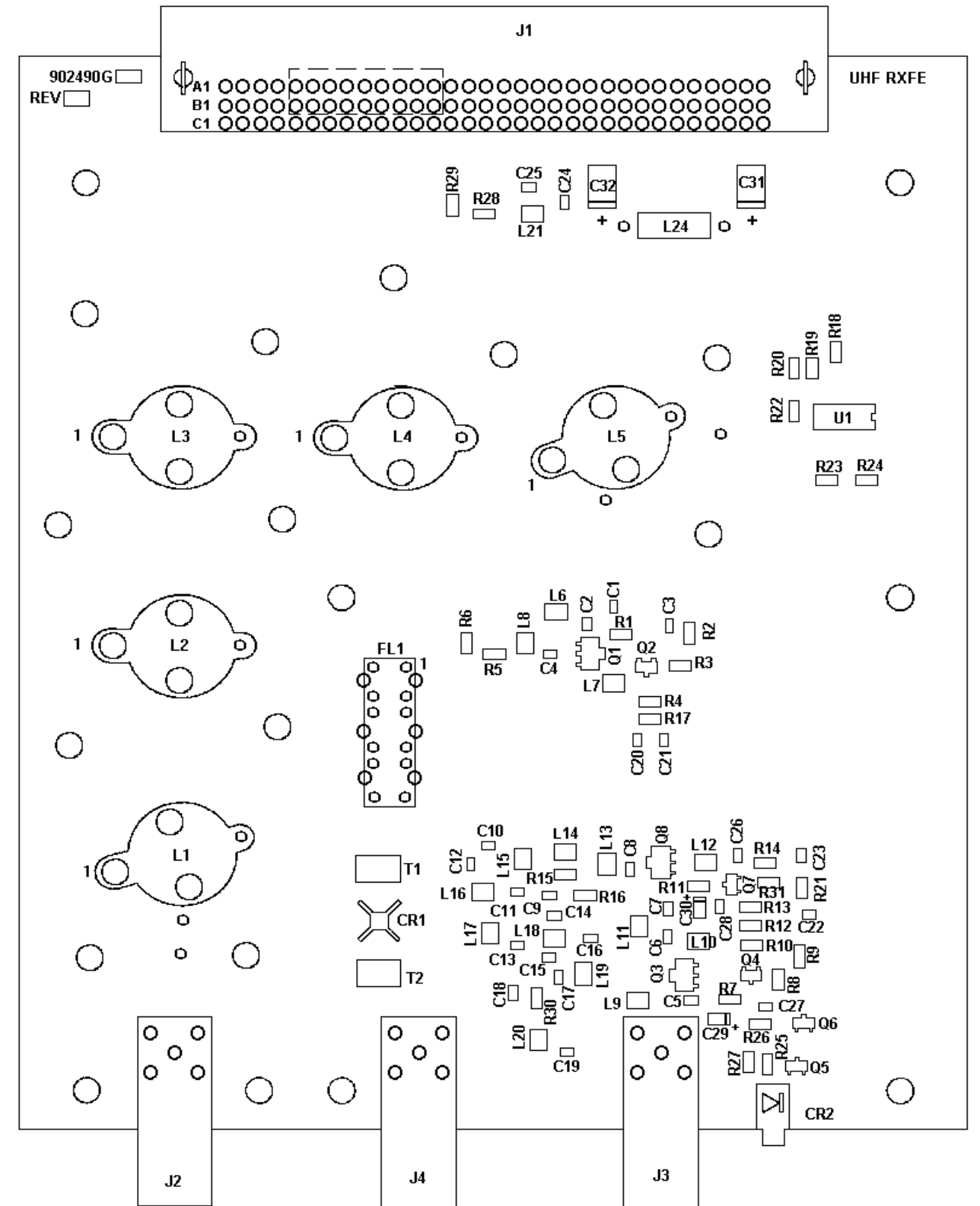
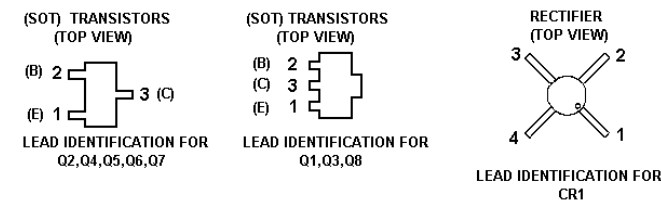
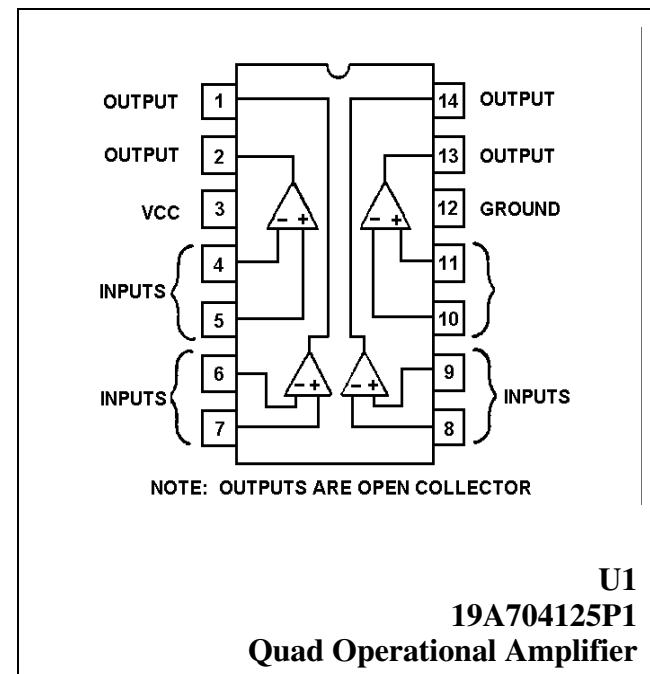

RECEIVER FRONT END BOARD 19D902490G3

(19D902490, Sh. 3, Rev. 5)

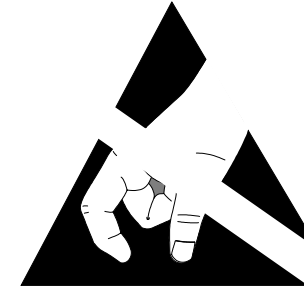
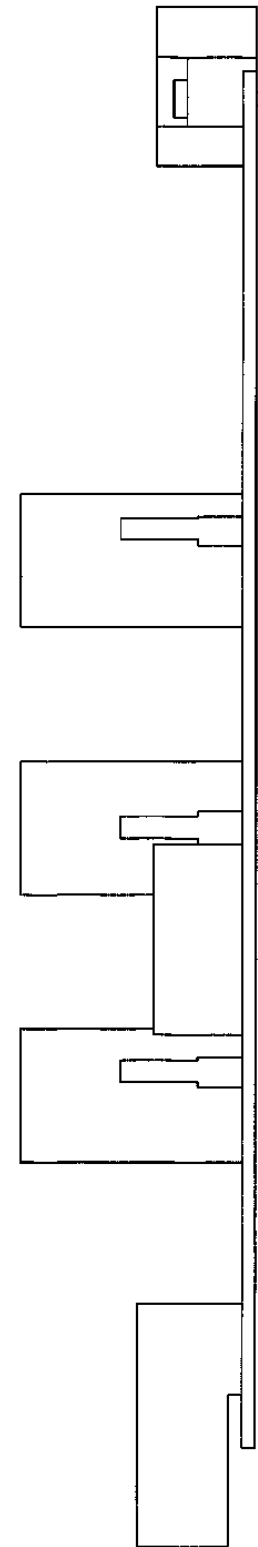
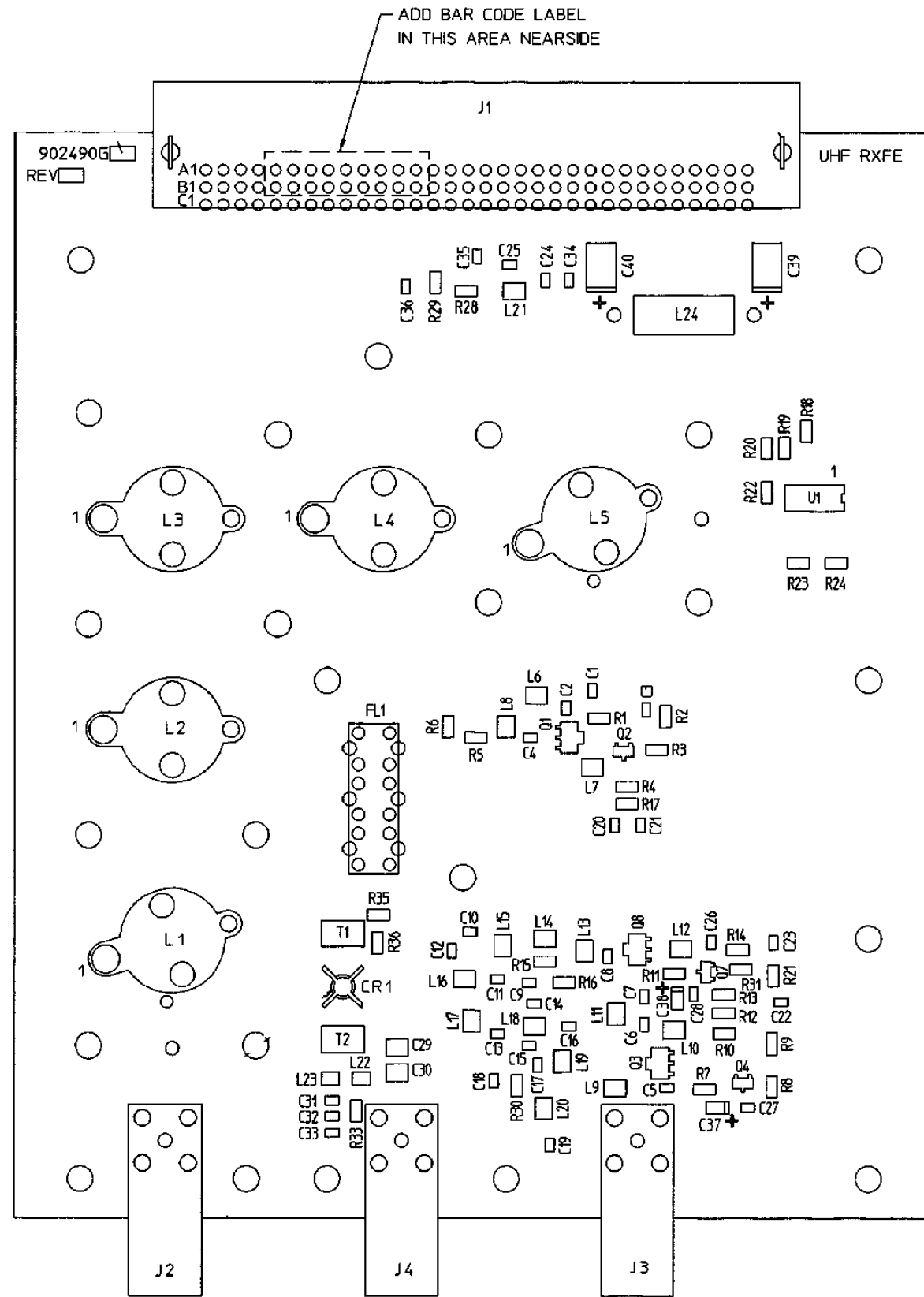

CAUTION

OBSERVE PRECAUTIONS FOR HANDLING

ELECTROSTATIC SENSITIVE DEVICES

(SOT) TRANSISTORS (TOP VIEW)

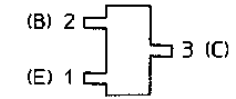

LEAD IDENTIFICATION FOR Q2, Q4, Q7

(SOT) TRANSISTORS (TOP VIEW)

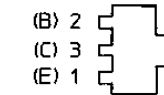

LEAD IDENTIFICATION FOR Q1, Q3, Q8

RECTIFIER (TOP VIEW)

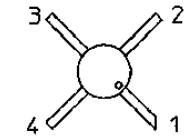

LEAD IDENTIFICATION FOR CR1

ETSI UPGRADEABLE (450-470 MHz)
ETSI (425-450 MHz)

PL ISSUED

**RECEIVER FRONT END BOARD
19D902490G4 & G7**

(19D902490, Sh. 4, Rev. 9)

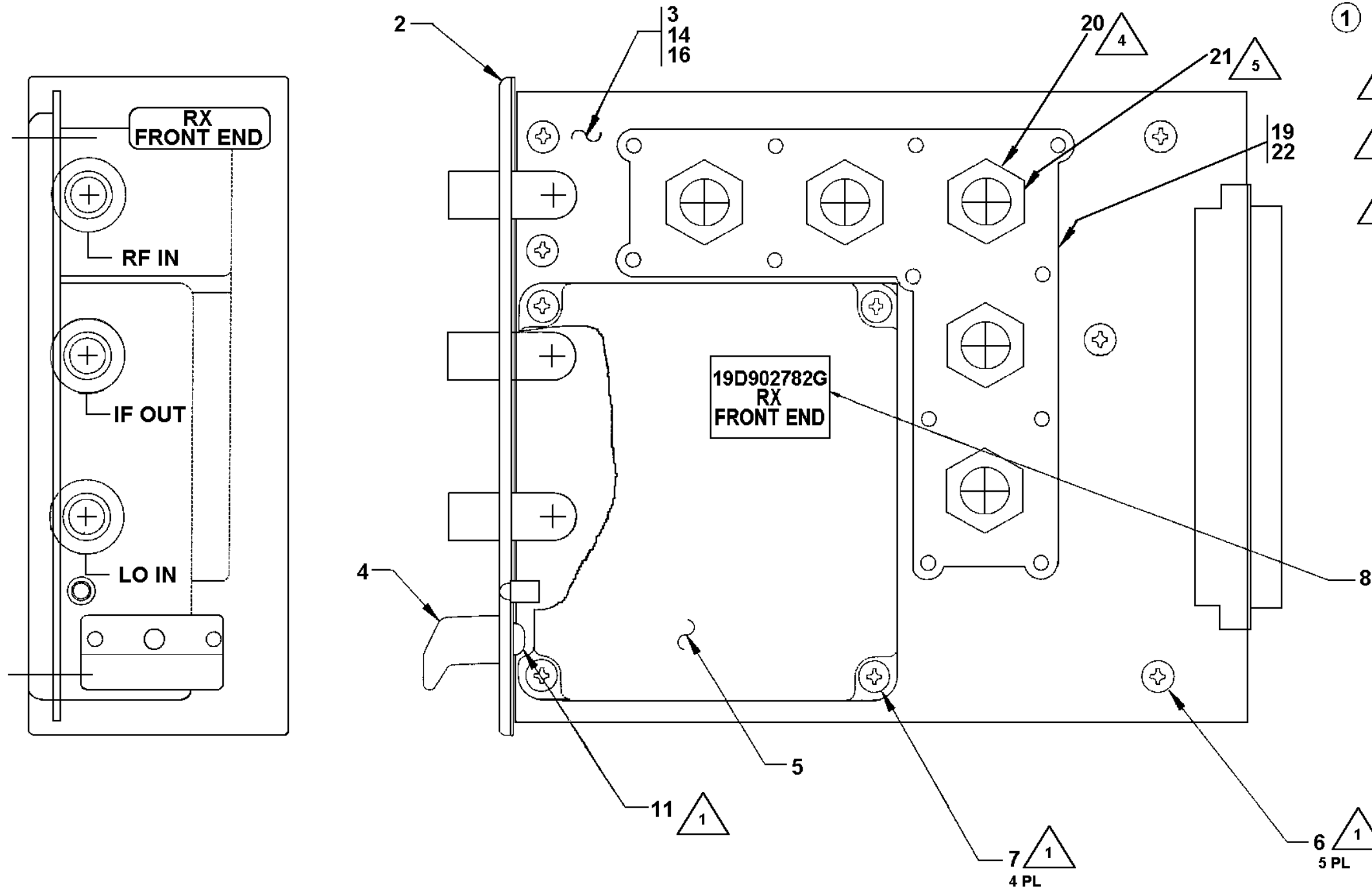

- ① NOTES:
- ① TORQUE SCREWS, ITEMS 6 & 7, TO 15.5 ± 1.3 INCH POUNDS. TORQUE SCREW, ITEM 11, TO 20 ± 1.3 INCH POUNDS.
 - ④ COAT THREADS OF TUNING SCREWS ITEM 20.
 - ⑤ TIGHTEN TUNING NUTS, ITEM 21 SO THAT TORQUE ON TUNING SCREWS, ITEM 20 ARE 100 IN. OZ. AT MIDDLE OF TUNING RANGE WITH POINTS ON TUNING NUTS BETWEEN RAISED SERRATIONS ON CASTINGS ITEM 19.

RECEIVER FRONT END MODULE
19D902782G3

(19D902782 Sh.1 Rev. 6)

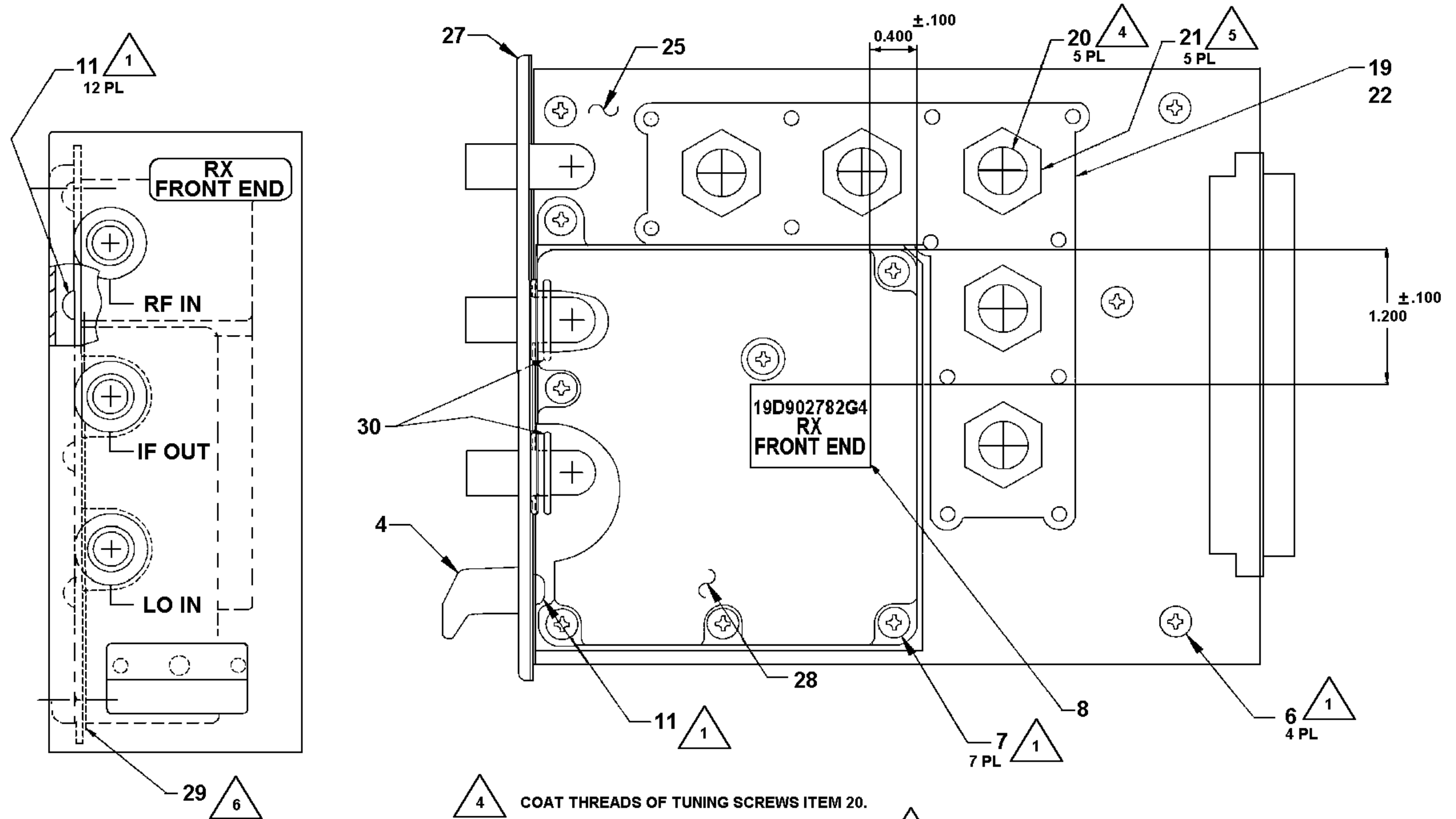

23 NOTES:

1 TORQUE SCREWS, ITEMS 6 & 7, TO 15.5 ± 1.3 INCH POUNDS. TORQUE SCREW, ITEM 11, TO 20 ± 1.3 INCH POUNDS.

4 COAT THREADS OF TUNING SCREWS ITEM 20.

5 TIGHTEN TUNING NUTS, ITEM 21 SO THAT TORQUE ON TUNING SCREWS, ITEM 20 ARE 100 IN. OZ. AT MIDDLE OF TUNING RANGE WITH POINTS ON TUNING NUTS BETWEEN RAISED SERRATIONS ON CASTINGS ITEM 19.

6 ITEM 29, GASKET MOUNTING HOLES TO ALIGN WITH ITEM 28, COVER.

**RECEIVER FRONT END MODULE
19D902782G4 & G7**

(19D902782 Sh.2 Rev. 6)

THIS SCHEMATIC DIAGRAM APPLIES TO	
MODEL NO.	REV LETTER
PL19D902490G4 (450-470MHz)	B
PL19D902490G7 (425-450MHz)	B
PL19D902782G4	1A
PL19D902782G7	1A

ALL RESISTORS ARE 1/4 WATT UNLESS OTHERWISE SPECIFIED AND RESISTOR VALUES ARE IN OHMS UNLESS FOLLOWED BY MULTIPLIER K OR M. CAPACITOR VALUES IN F UNLESS FOLLOWED BY MULTIPLIER U, N OR P INDUCTANCE VALUES IN H UNLESS FOLLOWED BY MULTIPLIER M OR U

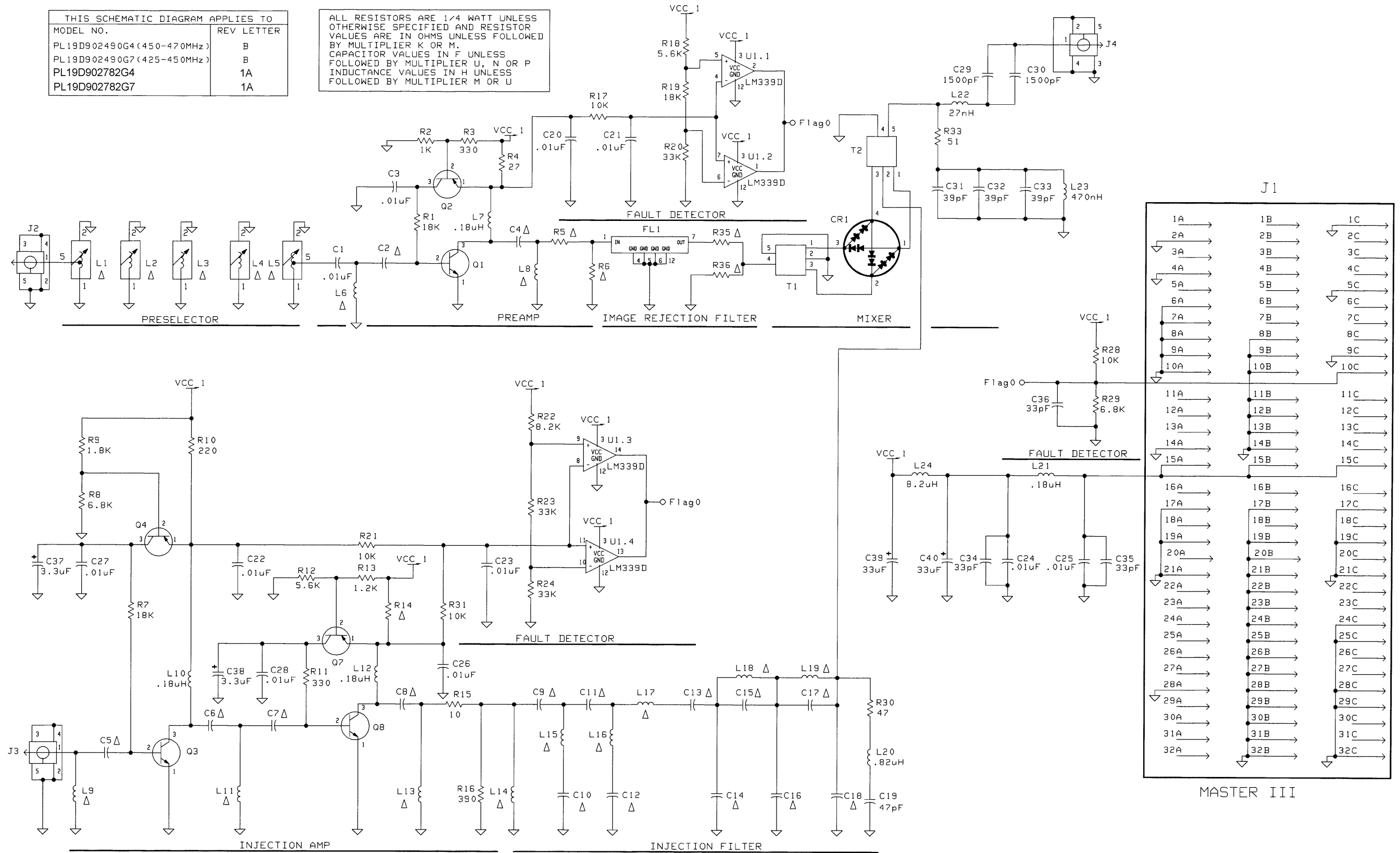

**RECEIVER FRONT END MODULE
19D902782G4 & G7**

(19D904768 Sh.1 Rev. 7)

COMPONENT	450-470 MHZ SPLIT (G450) Δ	450-470 MHZ SPLIT (G455) Δ	425-450 MHZ SPLIT (G425) Δ
C2	12pf	12pf	12pf
C4	8.2pf	8.2pf	100pf
C5	12pf	12pf	12pf
C6	82pf	82pf	100pf
C7	12pf	12pf	5.6pf
C8	22pf	22pf	120pf
C9	10pf	10pf	12pf
C10	6.8pf	6.8pf	15pf
C11	8.2pf	8.2pf	18pf
C12	10pf	10pf	15pf
C13	10pf	10pf	10pf
C14	3.9pf	3.9pf	3.3pf
C15	6.8pf	6.8pf	220pf
C16	3.9pf	3.9pf	3.3pf
C17	4.7pf	4.7pf	220pf
C18	3.9pf	3.9pf	3.3pf
FL1	HELICAL FILTER	HELICAL FILTER	HELICAL FILTER
L1	HELICAL COIL	HELICAL COIL	HELICAL COIL
L2	HELICAL COIL	HELICAL COIL	HELICAL COIL

COMPONENT	450-470 MHZ SPLIT (G450) Δ	450-470 MHZ SPLIT (G455) Δ	425-450 MHZ SPLIT (G425) Δ
L3	HELICAL COIL	HELICAL COIL	HELICAL COIL
L4	HELICAL COIL	HELICAL COIL	HELICAL COIL
L5	HELICAL COIL	HELICAL COIL	HELICAL COIL
L6	15nH	15nH	15nH
L8	33nH	33nH	33nH
L9	22nH	22nH	15nH
L11	12nH	12nH	22nH
L13	27nH	27nH	39nH
L14	18nH	18nH	10nH
L15	33nH	33nH	10nH
L16	22nH	22nH	12nH
L17	22nH	22nH	12nH
L18	10nH	10nH	15nH
L19	15nH	15nH	15nH
R5	10 OHMS	10 OHMS	0 OHMS
R6	390 OHMS	390 OHMS	NOT USED
R14	18 OHMS	10 OHMS	27 OHMS
R35	0 OHMS	0 OHMS	27 OHMS
R36	NOT USED	NOT USED	NOT USED

ALL RESISTORS ARE 1/4 WATT UNLESS OTHERWISE SPECIFIED AND RESISTORS VALUES ARE IN OHMS UNLESS FOLLOWED BY MULTIPLIER K OR M. CAPACITOR VALUES IN F UNLESS FOLLOWED BY MULTIPLIER U, N OR P INDUCTANCE VALUES IN H UNLESS FOLLOWED BY MULTIPLIER M OR U.

THIS SCHEMATIC DIAGRAM APPLIES TO	
MODEL NO.	REV LETTER
19D902490G3	D

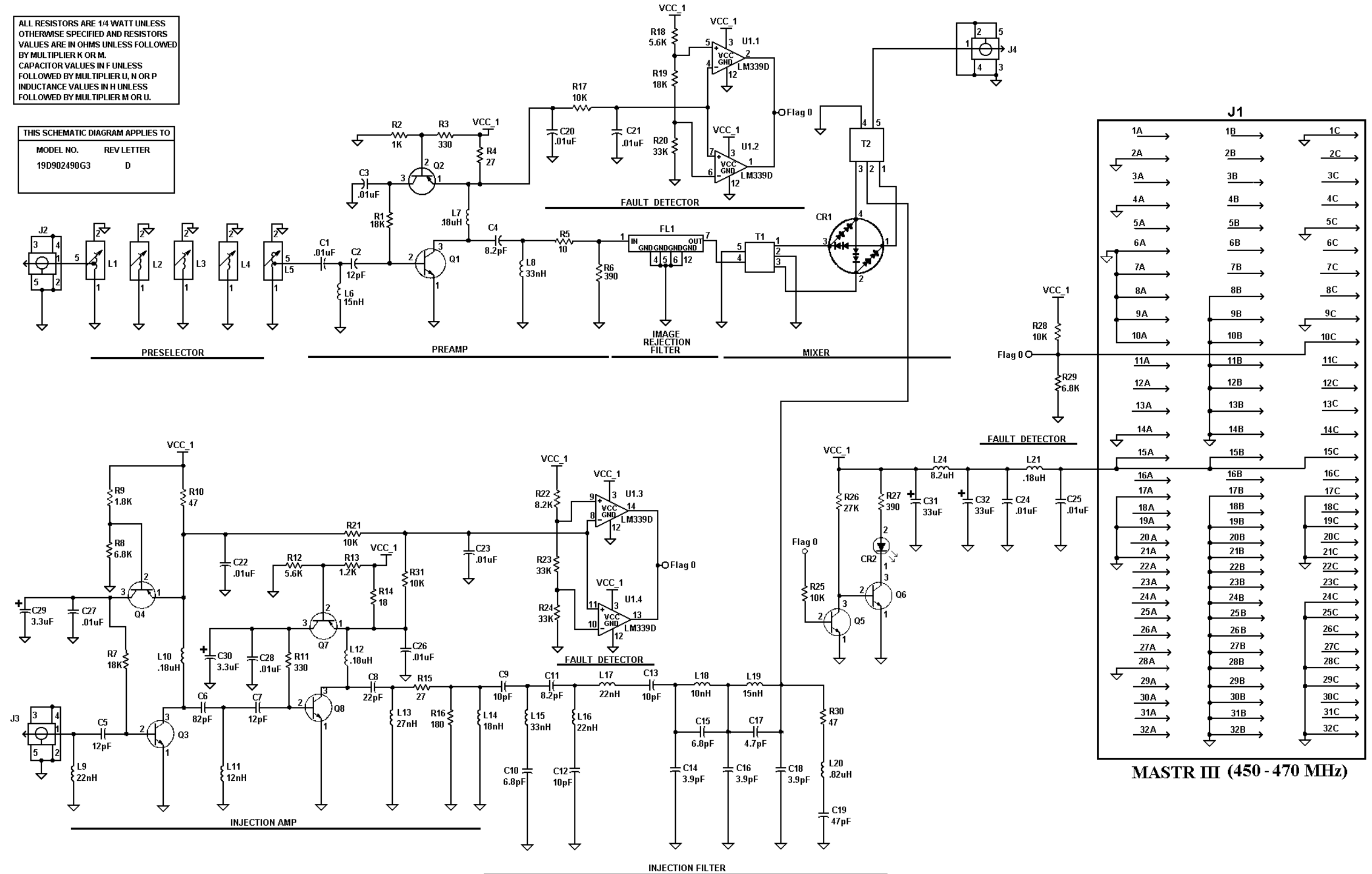

RECEIVER FRONT END MODULE
19D902782G3

(19D903498, Rev. 7)

This page intentionally left blank