

ADDENDUM NUMBER 2 TO MAINTENANCE MANUAL

LBI-38671N

Refer to ECO#20034647

GENERAL

This addendum updates information about the Printed Wire Board (PWB) for UHF Transmitter Synthesizer Module Boards 19D902780G1, G3, G6-G8, 19D902779G1, G3, G6-G8, and 19D903483G1, G3, G6-G8, G300.

PRODUCTION CHANGES

On page 6 of the manual, update the production changes to include the following information:

Rev. 4A – Transmitter Synthesizer Board 19D902780G1, G3, G6-G8

Rev. 9A – Transmitter Synthesizer Board 19D902779G1

Rev. AA – Transmitter Synthesizer Board 19D902779G3

Rev. 8A – Transmitter Synthesizer Board 19D902779G6-G8

Rev. 2A – Transmitter Synthesizer Board 19D903483G1, G3, G6-G8, G300

Change Inductor L2 from 19A705470P24, Inductor, Fixed, SMT, 0.82uH, 5%, 450 MA, to 19A705470P28, Inductor, Fixed, SMT, 1.8uH, 5%, 450 MA.

M/A-COM Wireless Systems

221 Jefferson Ridge Parkway

Lynchburg, Virginia 24501

(Outside USA, 434-385-2400) Toll Free 800-528-7711

www.macom-wireless.com

**ADDENDUM NUMBER 1 TO MAINTENANCE MANUAL
LBI-38671N**

GENERAL

This addendum updates information about the Printed Wire Board (PWB) for UHF Transmitter Synthesizer Module Boards 19D902779G3, G6-G10 in Maintenance Manual LBI-38671.

CHANGES

On page 7 of the manual, update the production changes to include the following information:

Rev. 9A - Transmitter Synthesizer Board 19D902779G3

Rev. 7A - Transmitter Synthesizer Board 19D902779G6-G8

Rev. 4A - Transmitter Synthesizer Board 19D902779G9

Rev. 5A - Transmitter Synthesizer Board 19D902779G10

To improve efficiency during manufacturing, change 19D903361P1 and 19D903361P1R3 to 19D903361P1R4 (peelable mask removed from center of 19D903361P1R3).

M/A-COM Wireless Systems

221 Jefferson Ridge Parkway

Lynchburg, Virginia 24501

(Outside USA, 434-385-2400) Toll Free 800-528-7711

www.macom-wireless.com

Printed in U.S.A.

UHF TRANSMITTER SYNTHESIZER MODULE 19D902780G3, G6 - G10

TABLE OF CONTENTS

	<u>Page</u>
DESCRIPTION	1
GENERAL SPECIFICATIONS	1
CIRCUIT ANALYSIS	1
VOLTAGE CONTROLLED OSCILLATOR	1
FREQUENCY DOUBLER	1
RF AMPLIFIERS	1
REFERENCE BUFFER AMPLIFIER	1
PRESCALER AND SYNTHESIZER	2
LOOP BUFFER AMPLIFIERS	2
AUDIO FREQUENCY AMPLIFIER	2
VOLTAGE REGULATORS	2
LOGIC CIRCUITS	3
BLOCK DIAGRAM	2
MAINTENANCE	3
TEST PROCEDURE	3
ALIGNMENT PROCEDURE	3
TROUBLESHOOTING	3
PARTS LIST	4
PRODUCTION CHANGES	6
IC DATA	7
OUTLINE DIAGRAM	9
SCHEMATIC DIAGRAM	10
ASSEMBLY DIAGRAM	Back Cover

ASSEMBLY DIAGRAM

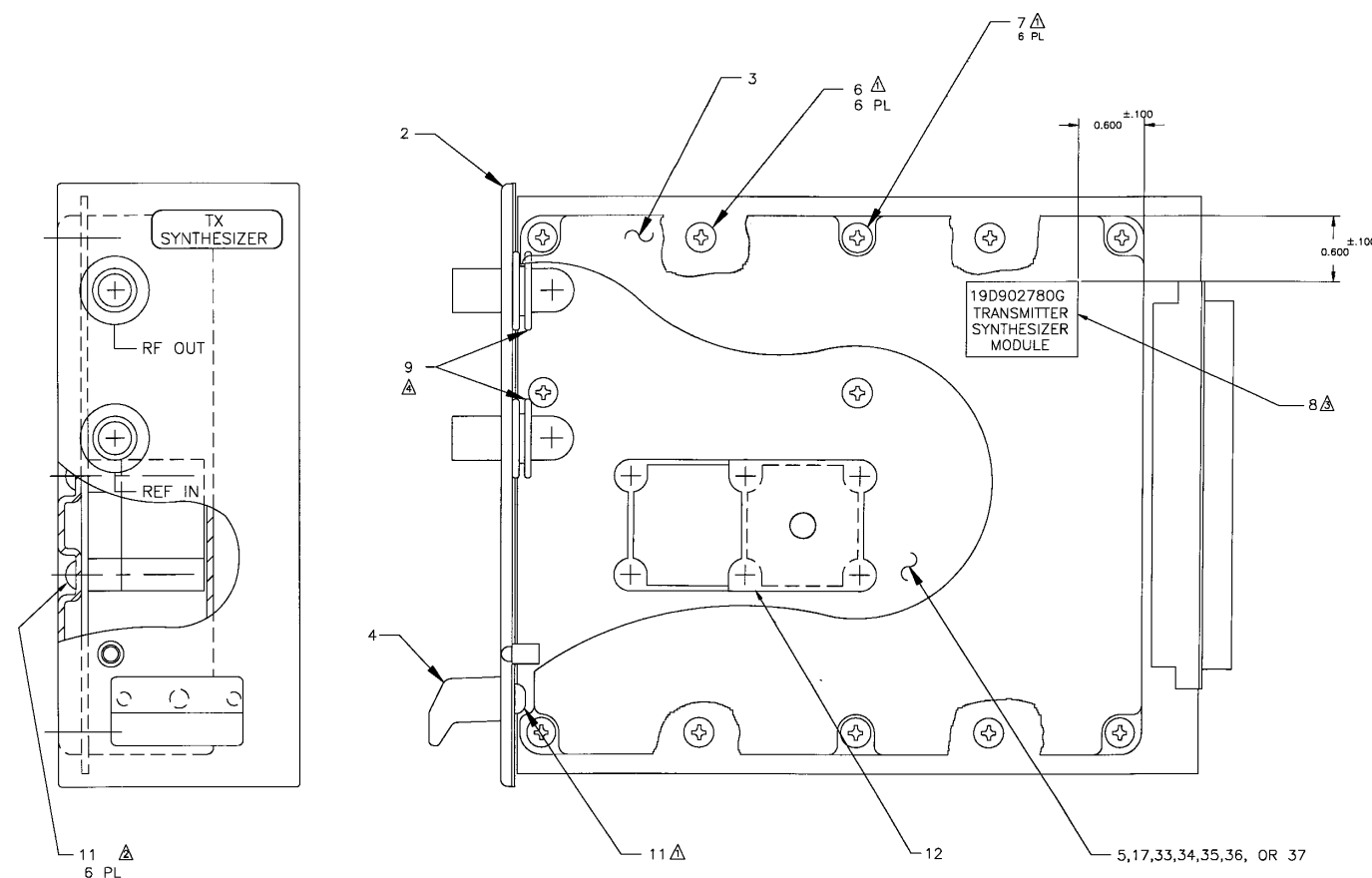

- ① NOTES:
- ▲ TORQUE SCREWS, ITEMS 6 AND 7, TO 15.5 ± 1.3 INCH POUNDS.
 - ▲ TORQUE SCREWS, ITEM 11, TO 20 ± 1.3 INCH POUND.
 - ▲ MARK AS SHOWN WITH APPLICABLE GROUP NUMBER PER 19A115740P1.
 - ▲ FORM ITEM 9 AROUND BNC CONNECTOR BEFORE ASSEMBLY OF COMPONENT BOARD (ITEM 5) WITH ITEM 2.

UHF TRANSMITTER SYNTHESIZER MODULE 19D902780G3, G6 - G10

(19D902780, Sh. 1, Rev. 7)

TABLE 1: GENERAL SPECIFICATIONS

ITEM	SPECIFICATION
FREQUENCY RANGE	450-470 MHz (G3) 425-450 MHz (G7) 403-430 MHz (G6) 380-400 MHz (G8) 470-494 MHz (G9) 490-512 MHz (G10)
CHANNEL SPACING	6.25 kHz
RF POWER OUT (50 Ohm load)	10 to 13 dBm (10 to 20 mW)
RF HARMONICS	< -30 dBc
NON-HARMONIC SPURS	
1 to 200 MHz	< -90 dBc
200 MHz to 1 GHz	< -60 dBc
CARRIER ATTACK TIME	<25 mSec
REFERENCE INPUT	
input level	0 dBm \pm 1.5dB
input impedance	50 Ohm
frequency	5 to 17.925 MHz (must be integer divisible by channel spacing)
MODULATION SENSITIVITY	5 kHz peak dev/1 Vrms, Adjustable
AF INPUT IMPEDANCE	600 Ohm
AF RESPONSE	
10 Hz	\pm 1.5 dB
1000 Hz 0 dB reference	
3 kHz	\pm 1.5 dB
10 Hz SQUARE WAVE MODULATION	<10%
Sq wave droop	
HUM & NOISE	-55 dB
POWER REQUIREMENTS	13.8 Vdc @ 275 mA -12.0 Vdc @ 10 mA

CREDITS

MASTR and EDACS are registered trademarks of M/A-COM, Inc.

All other brand and product names are trademarks, registered trademarks, or service marks of their respective holders.

DESCRIPTION

The principle function of the Transmitter Synthesizer Module is to provide the RF excitation for input to the MASTR® III station power amplifier. The output of the synthesizer is a frequency modulated signal at the desired frequency. The module contains the following functional blocks:

- A voltage controlled oscillator,
- Frequency Doubler (Multiplier),
- A chain of integrated circuit RF Amplifiers,
- A reference buffer amplifier,
- Dual modulus prescaler and synthesizer integrated circuits,
- Loop amplifiers and passive loop filter,
- An audio amplifier and a pre-modulation integrator.
- IC voltage regulators for +5 and -5 Vdc, a discrete component regulator for +8 Vdc, and an Operational Amplifier regulator for +4 Vdc.
- Logic circuitry: address decoder, input signal gates, and a lock indicator circuit.

CIRCUIT ANALYSIS

VOLTAGE CONTROLLED OSCILLATOR

Transistor Q1 and associated circuitry form a low noise Voltage Controlled Oscillator (VCO). Inductor L1 and associated capacitors form the oscillator resonant circuit (tank). The noise characteristic of this oscillator is dependent on the Q of this resonant circuit. The components used in the tank are specified to have especially high Q. Diode D1 aids in setting the bias point for low noise operation. (Any field replacement of oscillator parts should use identical parts.)

Variable Capacitor C10 sets the fixed capacitance in the tank, and therefore sets the frequency range over which the oscillator can be voltage tuned.

The oscillator frequency is voltage tuned by the signal applied through R5 and L5 to the two varicap diodes D2 and D3. Additionally, audio modulation is applied as an AF voltage to the two varicap diodes. This AF voltage varies the oscillator frequency at an audio rate (i.e., it frequency modulates the oscillator). Low frequency audio is applied along with the varicap control voltage through R5 and L5 while high frequency audio (MOD) is applied via C16.

Resistors R6 through R9 provide a two volt negative bias on the varicap diodes.

Transistors Q101 and Q102 and associated circuitry form the oscillator enable switch. This switch allows the station control circuitry to turn the VCO ON or OFF via the ANT_REL line. Setting the ANT_REL line to a logic low causes Q102 to conduct. The five (5) volt output at Q102 collector (OSCON) enables the fault indicator gates, U705-3 and U705-4, and turns on Q101. Q101 starts to conduct, providing a ground path for Q1. This turns ON the VCO.

FREQUENCY DOUBLER

Transistors Q801 and Q802 form a buffer stage to drive transistor multiplier Q803. The buffer isolates VCO Q1 from loading effects which could degrade oscillator loaded Q and hence noise performance. Transistor multiplier Q803 is tuned to pass the second harmonic of the VCO output and serves as a frequency doubler. Tank elements L802, C812-C814 and L803 form a resonant circuit and matching network to drive resistive splitter R201-R204.

RF AMPLIFIERS

The RF chain begins with resistive splitter R201-R204 and R216-R218. The output of the splitter at R203 is attenuated by 10 dB and provides impedance matching helical filter FL201, which is tuned to pass the fundamental while rejecting harmonics by approximately 40 dB. The output of FL201 is fed thru resistive pad R205-R207 to MMIC Amplifier U201 which operates in compression. U201 drives output amplifier U202 into compression. The output amplifier is followed by a bandpass filter (C208-C210, L203-L205) and resistive attenuators (R210-R215). The final output at the front panel BNC (J2) is nominally 11.5 dBm, and drives the station Power Amp.

The other output of the resistive splitter at R218 is attenuated by 20 dB and drives buffer amp U203 into compression. U203 drives the synthesizer prescaler providing a feedback signal for the synthesizer phase locked loop.

REFERENCE BUFFER AMPLIFIER

Transistor Q401 and associated components form a buffer amplifier for the reference oscillator signal. (The reference oscillator signal is produced by the receiver synthesizer module of a MASTR III station.) The 0 dBm reference oscillator signal is fed through the front panel BNC J1. Resistor R405 provides a 50 ohm load to the reference oscillator. The output of the Reference Buffer Amplifier is fed directly to the synthesizer integrated circuit. The output level at TP9 is approximately 3 volts peak to peak.

PRESCALER AND SYNTHESIZER

Integrated circuit U402 is the heart of the synthesizer. It contains the necessary frequency dividers and control circuitry to synthesize output frequencies by the technique of dual modulus prescaling. U402 also contains an analog sample and hold phase detector and a lock detector circuit.

Within the synthesizer (U402) are three programmable dividers which are loaded serially using the CLOCK, DATA, and ENABLE inputs (pins 11, 12, and 13 respectively). A serial data stream (DATA) on pin 12 is shifted into internal shift registers by low to high transitions on the clock input (CLOCK) at pin 11. A logic high (ENABLE) on pin 13 then transfers the program information from the shift registers to the divider latches.

The reference signal is applied to U402 pin 2 and divided by the "R" divider. This divides the reference signal down to a divided reference frequency (F_r). The typical reference frequency is 12.8 MHz and the typical divided reference frequency is 6.25 kHz providing for synthesizer steps of 6.25 kHz for use with both 12.5 kHz and 25 kHz channel spacing. Other channel spacings are possible by providing proper programming.

The "A" and "N" dividers process the loop feedback signal provided by the VCO (by way of the dual modulus prescaler U401). The output of the "N" divider is a divided version of the VCO output frequency (F_v).

Synthesizer U402 also contains logic circuitry to control the dual modulus prescaler U401. If the locked synthesizer output frequency is 450 MHz. The prescaler output nominally will be equal to 3.515625 MHz (450 MHz/128). This frequency is further divided down to F_v by the "N" divider in U402. F_v is then compared with F_r in the phase detector section.

The phase detector output voltage is proportional to the phase difference between F_v and F_r . This phase detector output serves as the loop error signal. This error signal voltage tunes the VCO to whatever frequency is required to keep F_v and F_r locked (in phase).

LOOP BUFFER AMPLIFIERS AND LOOP FILTER

The error signal provided by the phase detector output is buffered by operational amplifiers (op-amp) U501A and U501B. The audio modulation signal from U601B is also applied to the input of U501B. The output of U501B is the sum of the audio modulation and the buffered error signal.

The output of the second buffer (U501B) is applied to a loop filter consisting of R506, R507, R508, C505 and C506. This filter controls the bandwidth and stability of the synthesizer loop. The UHF transmitter synthesizer has a loop bandwidth of only several Hertz. This is very narrow, resulting in an excessively long loop acquisition time. To speed acquisition, switches U502A and U502C bypass the filter circuit whenever an ENABLE pulse is received by the Input Gates.

AUDIO FREQUENCY AMPLIFIER

The transmitter synthesizer audio input line is fed to U601A. U601A is configured as a unity gain op-amp. Resistor R601 sets the 600 ohm input impedance of this amplifier. (NOTE: Data for digital modulation is fed to the synthesizer through the audio input line.)

The amplifier output is split into two components and fed to two variable resistors VR601 and VR602. VR601 sets the level in the low frequency audio path and VR602 sets the level in the high frequency audio path. (There is no clear break between the low and high frequency ranges. All voice frequencies are within the high frequency range. The low frequency range contains low frequency data components.)

The wiper of VR601 (low frequency path) connects to the input of U601B, the pre-modulation integrator. U601B performs the function of a low-pass filter and integrator. The integrator output is summed with the PLL control voltage at the input of loop buffer amplifier U501B. This integrated audio signal phase modulates the VCO. The combination of pre-integration and phase modulation is equivalent to frequency modulation.

The wiper of VR602 (high frequency path) is connected to the modulation input of the VCO through C16.

VOLTAGE REGULATORS

U301 and U303 are monolithic voltage regulators (+5 Vdc and -5 Vdc respectively). These two voltages are used by synthesizer circuitry. The +5 V regulator output is also used as a voltage reference for the +8 Vdc discrete regulator circuit.

U302A, Q302 and associated circuitry from the +8 volt regulator. Most module circuitry is powered from the +8 volt line. The regulator is optimized for especially low noise performance. This is critical because the low noise VCO is powered by the +8 volt line.

The +8 Vdc line also feeds the +4 Vdc regulator, U302B and associated resistors. The +4 Vdc regulator provides a bias voltage for several op-amps in the module.

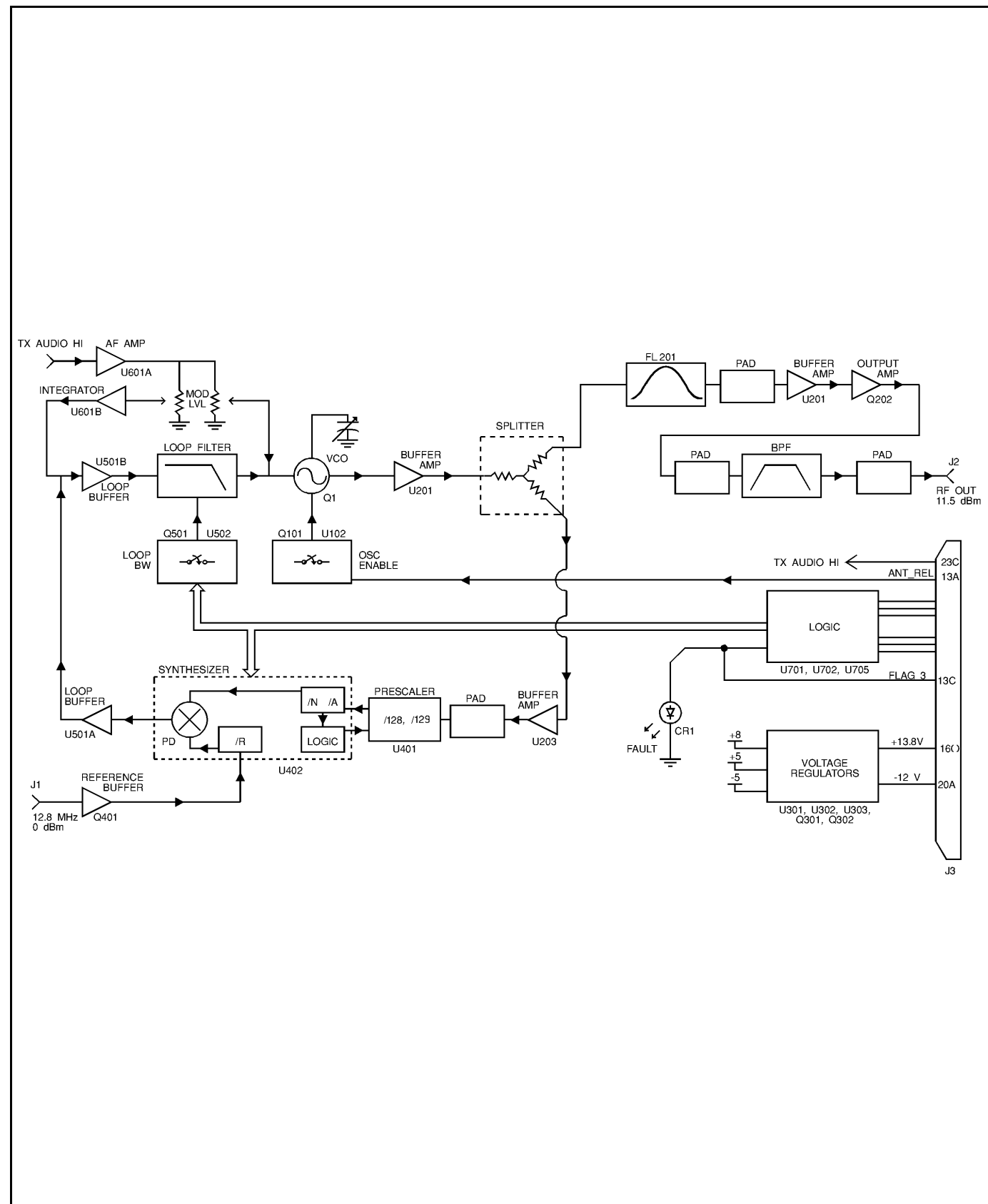

Figure 1: Block Diagram

LOGIC CIRCUITS

Logic circuitry (other than that inside the synthesizer IC - U402) consists of the following:

- An address decoder
- Input gates and level shifters
- Lock Indicator circuitry

The address decoder, U702, enables the Input Gates when the A0, A1, and A2 input lines receive the proper logic code (110 for the transmitter synthesizer). After receiving the proper code, Y3 (U702-12) sends a logic low signal to U701C. U701C acts as an inverter and uses the logic high output to turn on Input Gates U701A, U701B, and U701D. The Input Gates allow the clock, data and enable information to pass on to the synthesizer via the level shifters. The Level Shifter Transistors Q701, Q702 and Q703 convert the 5 volt gate logic level to the 8 volt logic level required by the synthesizer U402.

The Fault Indicator circuitry indicates when the synthesizer is in an out-of-lock condition. The fault detector latches, U705A and U705B are reset by the enable pulse during initial loading of data into the synthesizer. If at any time afterwards the lock detector signal (LD) goes low, the high output of U705B will cause the output of gates U705C and U705D to go low. The low output from U705C causes Q704 to conduct turning on the front panel LED (CR701). The output of U705D (FLAG) is connected to J3-13C for external monitoring of the Synthesizer Module. A logic low on the FLAG line indicates an out-of-lock condition.

MAINTENANCE

RECOMMENDED TEST EQUIPMENT

The following test equipment is required to test the synthesizer Module:

- RF signal source for 12.8 MHz, 0 dBm reference (included with item 10)
- AF Generator or Function Generator
- Modulation Analyzer; HP 8901A, or equivalent, or a UHF receiver
- Oscilloscope; 20 MHz
- DC Meter; 10 meg ohm (for troubleshooting)
- Power Supply; 13.8 Vdc @ 350 mA
- 12.0 Vdc @ 25 mA
- Spectrum Analyzer; 0-1 GHz
- Frequency Counter; 10 MHz - 500 MHz
- Personal Computer (IBM PC compatible) to load frequency data
- Service Parts Kit, (TQ-0650), (includes software for loading frequency data)

SERVICE NOTES

The following service information applies when aligning, testing, or troubleshooting the TX Synthesizer:

- Standard Modulating Signal = 1 kHz sinusoidal voltage, 0.6 Vrms at the module input terminals (600 ohm R_{in}).
- The input audio level for setting the 4.5 kHz or 10 Hz (or 7 Hz) deviation should always be 1.00 Vrms.
- In the modulation adjustment, any reference to 0.6 Vrms refers to the voltage level for a STANDARD signal, usually 60% (3.0 kHz) of maximum deviation. The 0.6 Vrms will produce 60% of full deviation.
- Logic Levels:
Logic 1 = High = 4.5 to 5.5 Vdc
Logic 0 = Low = 0 to 0.5 Vdc
- Transmitter Synthesizer Address = A0 A1 A2 = 110
- Synthesizer data input stream is as follows:
14-bit "R" divider most significant bit (MSB) = R13 through "R" divider least significant bit (LSB) = R0
10-bit "N" divider MSB = N9 through "N" divider LSB = N0
7-bit "A" divider MSB = A6 through "A" divider LSB = A0
Single High Control Bit (last bit)
Latched When Control Bit = 1

DATA ENTRY FORMAT

Latched When
Control Bit = 1

Data in	Last Bit	A0	-----	A6	N0	-----	N9	R0	-----	R13	Data out
	LSB			MSB	LSB		MSB	LSB			
	Control B										

- For the transmitter synthesizer, 5 kHz channel spacing
R = 2560
N = integer part of (frequency in kHz)/(320)
A = (frequency in kHz)/(5) - 64*N
All numbers must be converted to binary.
- ANT_REL line must be logic low (0V) in order to lock synthesizer.
 - Synthesizer lock is indicated by the extinguishing of the front panel LED indicator and a logic high on the fault flag line (J3 pin 13C).
 - Always verify synthesizer lock after each new data loading.

TEST PROCEDURE

(Steps 5, 6, and 7 can be done using a modulation analyzer or UHF receiver with 750 μs de-emphasis switchable in or out.)

1. Program synthesizer at 470.0 (G3), 430 (G6), 450 (G7), 400 (G8), 494 (G9) or 512 (G10) MHz using the System Module personality or test software if using RF Test Fixture TQ-0650.
Verify lock (flag = high).
Verify front panel LED is off.
2. Measure output frequency.
Verify frequency = 470.0000 (G3), 425.000 (G6) or 450.000 (G7) MHz, 400.000 (G8), 494.000 (G9) or 512.000 (G10) ±200 Hz.
3. Measure harmonic content.
Verify 2nd harmonic is < -30 dBc.
4. Measure RF power output into 50 ohm load.
Verify 10 to 13 dBm (10 to 20 mW).
5. Measure AF distortion with standard modulating signal input.
Verify <2.5%.
6. Measure Hum and Noise relative to 0.44 kHz average deviation, (de-emphasis on).
Verify < -55dB.
7. Measure AF response at 300 Hz, 1 kHz (ref) and 3 kHz, (de-emphasis off).
Verify within ±1.5 dB with respect to 1 kHz reference.
8. Verify lock at different frequencies.
 - a. Program synthesizer at 380 (G8), 450 (G3), 403 (G6), 425 (G7), 470 (G9) or 492 (G10) MHz. Verify LED is off.
 - b. Program synthesizer at 385 (G8), 455 (G3), 408.5 (G6), 430 (G7), 476 (G9) or 497 (G10) MHz. Verify LED is off.
 - c. Program synthesizer at 395 (G8), 465 (G3), 419.5 (G6), 445 (G7), 488 (G9) or 507 (G10) MHz. Verify LED is off.
 - d. Program synthesizer at 400 (G8), 470 (G3), 425 (G6), 450 (G7), 494 (G9) or 512 (G10) MHz. Verify LED is off.

ALIGNMENT PROCEDURE

1. Apply +13.8 Vdc and -12 Vdc. Verify the current drain on the 13.8 volt supply is <300mA and the current drain on the -12 volt supply is <20 mA.
2. Program the synthesizer at 380 (G8), 450 (G3), 403 (G6), 425 (G7), 470 (G9) or 492 (G10) MHz. Adjust trimmer C10 until Vtest (23A) reads 2.5 (G3, G8), 2.0 (G6, G7, G9) or 3.0 (G10) ±0.05Vdc.
3. Program synthesizer at 460.0 (G3), 390.0 (G8), 414 (G6) or 437.5 (G7), 482 (G9) or 502 (G10) MHz for the following three adjustments:
 - Set VR602 for 4.5 kHz peak deviation with a standard modulating signal applied to the audio input.
 - Set VR601 for 4.5 kHz peak deviation with 1.0 Vrms, 10 Hz (or 7 Hz for G3) sine wave audio applied to module AF input.
 - Apply a 10 Hz 1.4 Vpk square wave to module AF input. Adjust VR601 slightly for the flattest demodulated square wave using a modulation analyzer or receiver (no de-emphasis) and an oscilloscope. The maximum net variation in voltage over 1/2 cycle is 5%.

NOTE

This adjustment is critical for EDACS® application and must be reset at customer frequency.

WARNING

FL201 has been aligned at the vendor to meet passband and stopband specifications and is not be realigned by the factory or field technicians.

TROUBLESHOOTING

A troubleshooting guide is provided showing typical measurements at the various test points.

WARNING

FL201 has been aligned at the vendor to meet passband and stopband specifications and is not be realigned by the factory or field technicians.

TROUBLESHOOTING GUIDE

SYMPTOM	CHECK (CORRECT READINGS SHOWN)	INCORRECT READING INDICATES DEFECTIVE COMPONENT
Synthesizer Fails To Lock	Check DC voltages +5 V @ U301 Pin 1 +8 V @ Q301 collector -5 V @ U303 Pin 1	U301 or associated components U302, Q301, Q302 or associated components U303 or associated components
	Check 12.8 MHz reference signal 3V P-P, 12.8 MHz @ U402 Pin 2 Check oscillator signal	No reference signal to front panel BNC or Q401
	11.5 ±1.5 dBm 435 to 485 MHz at front panel BNC Check prescaler output 1V P-P, 3.5 MHz @ U401 Pin 4 Check CLOCK, DATA, ENABLE While loading frequency data into synthesizer Check 8V logic signals @ Pins 11, 12, 13 of U402 Check Phase detector output 6.25 kHz random signal @ U501 Pin 7	Proceed to "Low/No RF output" below U202, U401 Wrong address or U701, U702, Q701, Q702, Q703 U402, U501
Low/No RF Output	Check oscillator LESS than 0.5 Vdc @ collector of Q101 Check RF chain	Synthesizer not keyed (low on ANT relay line) or Q101, Q102
No Modulation	Check AF amplifier Apply 1V, 1 kHz signal to TX/Audio/Hi Check 1V signal @ U601 Pin 1	U601

UHF TRANSMITTER SYNTHESIZER MODULE
19D902780G3, G6 - G10
ISSUE 12

SYMBOL	PART NO.	DESCRIPTION
----- MISCELLANEOUS -----		
2	19D902508P4	Chassis.
3	19D902509P10	Cover.
4	19D902555P1	Handle.
6	19A702381P506	Screw, thread forming: TORX, No. M3.5-6 x 6.
7	19A702381P513	Screw, thread forming: TORX, No. M3.5 - 0.6 X 13.
9	19B802690P2	RF Shielding Grommet
11	19A702381P508	Screw, thd. form: No. 3.5-0.6 x 8.
12	19D902824P1	Casting.
	AG102834V1	Gasket, EMI Shield
TRANSMITTER SYNTHESIZER BOARD 19D902779G3, G6 - G10		
----- CAPACITORS -----		
C1	19A702236P25	Ceramic: 10 pF + or -5 pF, 50 VDCW, temp coef + or -30 PPM/°C.
C2	19A702236P32	Ceramic: 18 pF + or -5%, 50 VDCW, temp coef 0 + or -30 PPM
C3	19A702236P28	Ceramic: 12 pF + or - 5%, 50 VDCW, temp coef 0 + or -30 PPM.
C4	19A702236P10	Ceramic: 2.2pF + or - 0.25pF, 50 VDCW, temp coef 0 + or - 30 PPM/°C (Used in G3).
C4	19A702236P1	Ceramic: 0.5pF + or - 0.25pF, 50 VDCW, temp coef 0 + or - 30 PPM/°C (Used in G8).
C4	19A702236P17	Ceramic: 4.7pF + or - 5%, 50 VDCW, temp coef 0 + or - 60 PPM/°C (Used in G9).
C4	19A702236P11	Ceramic: 2.7pF + or - 5%, 50 VDCW, temp coef 0 + or - 30 PPM/°C (Used in G10).
C5	19A702236P17	Ceramic: 4.7pF + or - 5%, 50 VDCW, temp coef 0 + or - 60 PPM/°C (Used in G3, G6 & G8 through G10).
C5	19A702236P25	Ceramic: 10pF + or - 0.25pF, 50 VDCW, temp coef 0 + or - 30 PPM/°C (Used in G7).
C6	19A702236P28	Ceramic: 12 pF + or - 5%, 50 VDCW, temp coef 0 + or -30 PPM. (Used in G3).
C6	19A702236P30	Ceramic: 15 pF + or -5%, 50 VDCW, temp coef 0 + or -30 PPM/°C. (Used in G6 & G7).
C6	19A702236P32	Ceramic: 18 pF + or - 5%, 50 VDCW, temp coef 0 + or -30 PPM. (Used in G8).
*C6	19A702236P28	Ceramic: 12 pF + or -5%, 50 VDCW, temp coef 0 + or -30 PPM/°C. (Used in G9 & G10).
C7	19A702061P99	Ceramic: 1000 pF + or -5%, 50 VDCW, temp coef 0 + or -30 PPM/°C.
C8	19A702052P14	Ceramic: 0.01 uF + or - 10%, 50 VDCW.
C9	19A705205P6	Tantalum: 10 uF, 16 VDCW; sim to Sprague 293D.
C10	19A134227P5	Variable: 1.5 to 14 pF, 100 VDCW.
C11	19A705205P2	Tantalum: 1 uF, 16 VDCW; sim to Sprague 293D.
C12	19A702052P14	Ceramic: 0.01 uF + or - 10%, 50 VDCW.
C13 and C14	19A702061P99	Ceramic: 1000 pF + or -5%, 50 VDCW, temp coef 0 + or -30 PPM/°C.
*C15	19A700004P6	Metallized polyester: 4.7 uF + or - 10%, 63 VDCW.
*C16	19A702052P106	Ceramic: 1500 pF + or -5%, 50 VDCW.
C17	19A702061P99	Ceramic: 1000 pF + or -5%, 50 VDCW, temp coef 0 + or -30 PPM/°C.
C18 and C19	19A705205P2	Tantalum: 1 uF, 16 VDCW; sim to Sprague 293D.
C101	19A702061P99	Ceramic: 1000 pF + or -5%, 50 VDCW, temp coef 0 + or -30 PPM/°C.
C102	19A705205P2	Tantalum: 1 uF, 16 VDCW; sim to Sprague 293D.
C103	19A702061P99	Ceramic: 1000 pF + or -5%, 50 VDCW, temp coef 0 + or -30 PPM/°C.

*COMPONENTS, ADDED, DELETED OR CHANGED BY PRODUCTION CHANGES

SYMBOL	PART NO.	DESCRIPTION
C201	19A702061P61	Ceramic: 100 pF + or - 5%, 50 VDCW, temp coef 0 + or - 30 PPM.
C202	19A702061P99	Ceramic: 1000 pF + or -5%, 50 VDCW, temp coef 0 + or -30 PPM/°C.
C203	19A705205P2	Tantalum: 1 uF, 16 VDCW; sim to Sprague 293D.
C204 and C205	19A702061P61	Ceramic: 100 pF + or - 5%, 50 VDCW, temp coef 0 + or - 30 PPM.
C206	19A702061P99	Ceramic: 1000 pF + or -5%, 50 VDCW, temp coef 0 + or -30 PPM/°C.
C207	19A705205P2	Tantalum: 1 uF, 16 VDCW; sim to Sprague 293D.
C208	19A702236P25	Ceramic: 10pF + or - 5%, 50 VDCW, temp coef 0 + or - 30 PPM/°C (Used in G3).
C208	19A702236P28	Ceramic: 12pF + or - 5%, 50 VDCW, temp coef 0 + or - 30 PPM/°C.
C209	19A702236P9	Ceramic: 1.8pF + or - 0.25 pF, 50 VDCW, temp coef 0 + or - 30 PPM/°C (Used in G3).
C209	19A702236P10	Ceramic: 2.2pF + or -0.25 pF, 50 VDCW, temp coef 0 + or - 30 PPM/°C (Used in G6, G7, G8).
C209	19A702236P8	Ceramic: 1.8pF + or -0.25 pF, 50 VDCW, temp coef 0 + or - 30 PPM/°C (Used in G9).
C209	19A702236P9	Ceramic: 1.5pF + or -0.25 pF, 50 VDCW, temp coef 0 + or - 30 PPM/°C (Used in G10).
C210	19A702236P25	Ceramic: 10pF + or - 5%, 50 VDCW, temp coef 0 + or - 30 PPM (Used in G3).
C210	19A702236P28	Ceramic: 12pF + or - 5%, 50 VDCW, temp coef 0 + or - 30 PPM/°C.
C211 and C212	19A702061P61	Ceramic: 100 pF + or - 5%, 50 VDCW, temp coef 0 + or - 30 PPM.
C213	19A705205P2	Tantalum: 1 uF, 16 VDCW; sim to Sprague 293D.
C214	19A702061P99	Ceramic: 1000 pF + or -5%, 50 VDCW, temp coef 0 + or -30 PPM/°C.
C215	19A702061P61	Ceramic: 100 pF + or - 5%, 50 VDCW, temp coef 0 + or - 30 PPM.
C301	19A702061P99	Ceramic: 1000 pF + or -5%, 50 VDCW, temp coef 0 + or -30 PPM/°C.
C302	19A702052P14	Ceramic: 0.01 uF + or - 10%, 50 VDCW.
C303 and C304	19A705205P2	Tantalum: 1 uF, 16 VDCW; sim to Sprague 293D.
C305	19A705205P7	Tantalum: 10 uF, 25 VDCW; sim to Sprague 293D.
C306	19A705205P2	Tantalum: 1 uF, 16 VDCW; sim to Sprague 293D.
C307	19A705205P6	Tantalum: 10 uF, 16 VDCW; sim to Sprague 293D.
C308 and C309	19A702061P99	Ceramic: 1000 pF + or -5%, 50 VDCW, temp coef 0 + or -30 PPM/°C.
C310	19A705205P6	Tantalum: 10 uF, 16 VDCW; sim to Sprague 293D.
C311	19A705205P2	Tantalum: 1 uF, 16 VDCW; sim to Sprague 293D.
C312	19A702061P99	Ceramic: 1000 pF + or -5%, 50 VDCW, temp coef 0 + or -30 PPM/°C.
C313	19A705205P6	Tantalum: 10 uF, 16 VDCW; sim to Sprague 293D.
C314	19A702061P99	Ceramic: 1000pF + or - 5%, 50 VDCW, temp coef 0 + or - 30 PPM/°C.
C401	19A702052P14	Ceramic: 0.01 uF + or - 10%, 50 VDCW.
C402	19A702061P99	Ceramic: 1000 pF + or -5%, 50 VDCW, temp coef 0 + or -30 PPM/°C.
C403 thru C405	19A702052P14	Ceramic: 0.01 uF + or - 10%, 50 VDCW.
C406	19A702061P99	Ceramic: 1000 pF + or -5%, 50 VDCW, temp coef 0 + or -30 PPM/°C.
C407	19A702052P14	Ceramic: 0.01 uF + or - 10%, 50 VDCW.
C408	19A702061P99	Ceramic: 1000 pF + or -5%, 50 VDCW, temp coef 0 + or -30 PPM/°C.
C409	19A705205P6	Tantalum: 10 uF, 16 VDCW; sim to Sprague 293D.
C410	19A702052P26	Ceramic: 0.1uF + or - 10%, 50 VDCW

PARTS LIST

LBI-38671N

SYMBOL	PART NO.	DESCRIPTION	SYMBOL	PART NO.	DESCRIPTION	SYMBOL	PART NO.	DESCRIPTION	SYMBOL	PART NO.	DESCRIPTION
C411	19A705205P6	Tantalum: 10 uF, 16 VDCW; sim to Sprague 293D.			----- JACKS -----	R203	19B800607P150	Metal film: 15 ohms + or -5%, 1/8 w.	R412	19B800607P823	Metal film: 82K ohms + or -5%, 1/8 w. (Used in G9 & G10).
C412	19A702052P14	Ceramic: 0.01 uF + or -10%, 50 VDCW.	J1 and J2	19A115938P24	Connector, receptacle.	R204	19B800607P101	Metal film: 100 ohms + or -5%, 1/8 w.	R415	19B800607P100	Metal film: 10 ohms + or -5%, 1/8 w.
C413	19A702052P108	Ceramic: 0.01 uF + or -10%, 50 VDCW.				R205	19B800607P331	Metal film: 330 ohms + or -5%, 1/8 w.	R501	19B800607P470	Metal film: 47 ohms + or -5%, 1/8 w.
C414	19A702061P69	Ceramic: 220 pF + or -5%, 50 VDCW, temp coef 0 + or -30 PPM/°C.	J3	19B801587P7	Connector, DIN: 96 male contacts, right angle to AMP 650887-1.	R206	19B800607P150	Metal film: 15 ohms + or -5%, 1/8 w.	R502	19B800607P102	Metal film: 1K ohms + or -5%, 1/8 w.
C501	19A705205P2	Tantalum: 1 uF, 16 VDCW; sim to Sprague 293D.			----- INDUCTORS -----	R207	19B800607P331	Metal film: 330 ohms + or -5%, 1/8 w.	R503	19B800607P223	Metal film: 22K ohms + or -5%, 1/8 w.
C502	19A705205P2	Tantalum: 1 uF, 16 VDCW; sim to Sprague 293D.	L1	19C851001P2	Coil, RF: 1 1/2 Turns, sim to Paul Smith SK-901-1. (Used in G8).	R208	19B800607P181	Metal film: 180 ohms + or -5%, 1/8 w.	R504	19B800607P150	Metal film: 15 ohms + or -5%, 1/8 w.
C503	19A702052P33	Ceramic: 0.1 uF + or -10%, 50 VDCW.	L1 L1	19C851001P2 19C851001P1	Coil, RF: sim to Paul Smith SK-901-1. (Used in G6). Coil, RF: sim to Paul Smith SK901-1. (Used in G6 - G7).	R209	19B800607P750	Metal film: 75 ohms + or -5%, 1/8 w.	R505	19B800607P104	Metal film: 100K ohms + or -5%, 1/8 w.
C504	19A702061P99	Ceramic: 1000 pF + or -5%, 50 VDCW, temp coef 0 + or -30 PPM/°C.	L2	19A705470P28	Coil, Fixed: 1.8 uH; sim to Toko 380LB-1R8M. (Used in G3, G9, & G10).	R210	19B800607P471	Metal Film: 470 Ohms + or -5%, 1/8 w (Used in G3).	R506	19B800607P105	Metal film: 1M ohms + or -5%, 1/8 w.
C505	19A703684P3	Metalized polyester: 2.2 uF + or -10%, 50 VDCW.	L2 thru L5	19A705470P24	Coil, Fixed: 0.82 uH; sim to Toko 380NB-R82M. (Used in G6 - G8).	R210	19B800607P331	Metal Film: 330 Ohms + or -5%, 1/8 w.	R507	19B800607P183	Metal film: 18K ohms + or -5%, 1/8 w. (Used IN G3, G6, G7, G8).
C506	19A703902P3	Metal: 0.047 uF + or -10%, 50 VDCW.	L201 and L202	19A705470P15	Coil, fixed: 0.15uH; sim to Toko 380NB-R15M.	*R211	19B800607P120	Metal Film: 12 Ohms + or -5%, 1/8 w (Used in G3, G9, G10).	*R507	19B800607P393	Metal film: 39K ohms + or -5%, 1/8 w. (Used in G9 & G10).
C507	19A702052P33	Ceramic: 0.1 uF + or -10%, 50 VDCW.	L203	19A705470P1	Coil, Fixed: 10 nH; sim to Toko 380NB-10nM.	R211	19B800607P150	Metal Film: 15 Ohms + or -5%, 1/8 w (Used in G6, G7, G8).	R508	19B800607P333	Metal film: 33K ohms + or -5%, 1/8 w. (Used IN G3, G6, G7, G8).
C602	19A705205P6	Tantalum: 10 uF, 16 VDCW; sim to Sprague 293D.	L204	19A705470P10	Coil, fixed: 47 nH: Sim to Toko 380NB-47nM (Used in G3 & G6 through G9).	R212 and R213	19B800607P471	Metal Film: 470 Ohms + or -5%, 1/8 w (Used in G3).	R508	19B800607P823	Metal film: 82K ohms + or -5%, 1/8 w. (Used in G9 & G10).
C603	19A702061P99	Ceramic: 1000 pF + or -5%, 50 VDCW, temp coef 0 + or -30 PPM/°C.	L204	19A705470P9	Coil, fixed: 47 nH: Sim to Toko 380NB-47nM (Used in G10).	R212 and R213	19B800607P331	Metal Film: 330 Ohms + or -5%, 1/8 w.	R509	19B800607P473	Metal film: 47K ohms + or -5%, 1/8 w.
C604	19A705205P2	Tantalum: 1 uF, 16 VDCW; sim to Sprague 293D.	L205	19A705470P1	Coil, Fixed: 10 nH; sim to Toko 380NB-10nM.	*R214	19B800607P120	Metal Film: 12 Ohms + or -5%, 1/8 w (Used in G3, G9, G10).	R510	19B800607P103	Metal film: 10K ohms + or -5%, 1/8 w.
C605	19A703684P3	Metalized polyester: 2.2 uF + or -10%, 50 VDCW.	L206	19A705470P15	Coil, fixed: .15uH; sim to Toko 380NB-R15M.	R214	19B800607P150	Metal Film: 15 Ohms + or -5%, 1/8 w (Used in G6, G7, G8).	R511 R601	19B800607P101 19A702931P176	Metal film: 100 ohms + or -5%, 1/8 w. Metal film: 604 ohms + or -1%, 200 VDCW, 1/8 w.
C701 thru C712	19A702061P61	Ceramic: 100 pF + or -5%, 50 VDCW, temp coef 0 + or -30 PPM.	L801 thru L803	19A705470P2	Coil, Fixed: 12 nH; sim to Toko 380NB-12nM.	R215	19B800607P471	Metal Film: 470 Ohms + or -5%, 1/8 w (Used in G3).	R602 and R603	19B800607P104	Metal film: 100K ohms + or -5%, 1/8 w.
C714 and C715	19A702061P99	Ceramic: 1000 pF + or -5%, 50 VDCW, temp coef 0 + or -30 PPM/°C.	Q1	19A702524P2	N-Type, field effect; sim to MMBFU310.	R215	19B800607P331	Metal Film: 330 Ohms + or -5%, 1/8 w.	R604	19B800607P470	Metal film: 47 ohms + or -5%, 1/8 w.
C801	19A702061P4	Ceramic: 1.8 pF + or -0.5 pF, 50 VDCW, temp or -250 PPM.	Q101	19A700076P2	Silicon, NPN: sim to MMBT3904, low profile.	R216	19B800607P510	Metal film: 51 ohms + or -5%, 1/8 w.	R605	19B800607P104	Metal film: 100K ohms + or -5%, 1/8 w.
C802	19A705205P6	Tantalum: 10 uF, 16 VDCW; sim to Sprague 293D.	Q102	19A700059P2	Silicon, PNP: sim to MMBT3906, low profile.	R217	19B800607P220	Metal film: 22 ohms + or -5%, 1/8 w.	R606	19B800607P680	Metal film: 68 ohms + or -5%, 1/8 w.
C803 and C804	19A702052P14	Ceramic: 0.01 uF + or -10%, 50 VDCW.	Q301	19A134577P2	Silicon, PNP: sim to Phillips BCX51-16.	R218	19B800607P330	Metal film: 33 ohms + or -5%, 1/8 w.	R607	19B800607P102	Metal film: 1K ohms + or -5%, 1/8 w.
C805	19A702061P99	Ceramic: 1000 pF + or -5%, 50 VDCW, temp coef 0 + or -30 PPM/°C.	Q302	19A700076P2	Silicon, NPN: sim to MMBT3904, low profile.	R219	19B800607P181	Metal film: 180 ohms + or -5%, 1/8 w.	R608	19B800607P392	Metal film: 3.9K ohms + or -5%, 1/8 w.
C806	19A702061P65	Ceramic: 150 pF + or -5%, 50 VDCW, temp coef 0 + or -30 PPM/°C.	Q401	19A704708P2	Silicon, NPN: sim to NEC 2SC3356.	R220	19B800607P104	Metal film: 100K ohms + or -5%, 1/8 w.	R609	19B800607P472	Metal film: 4.7K ohms + or -5%, 1/8 w.
C807	19A705205P6	Tantalum: 10 uF, 16 VDCW; sim to Sprague 293D.	Q501	19A700076P2	Silicon, NPN: sim to MMBT3904, low profile.	R221 and R222	19B800607P330	Metal film: 33 ohms + or -5%, 1/8 w.	R610	19B800607P105	Metal film: 1M ohms + or -5%, 1/8 w.
C808	19A702052P14	Ceramic: 0.01 uF + or -10%, 50 VDCW.	Q701 thru Q704	19A700076P2	Silicon, NPN: sim to MMBT3904, low profile.	R301 thru R303	19B800607P100	Metal film: 10 ohms + or -5%, 1/8 w.	R701 thru R706	19B800607P102	Metal film: 1K ohms + or -5%, 1/8 w.
C809	19A702061P13	Ceramic: 10 pF + or -5%, 50 VDCW, temp coef 0 + or -30 PPM.	Q801 thru Q803	19A704708P2	Silicon, NPN: sim to NEC 2SC3356.	R304	19B800607P470	Metal film: 47 ohms + or -5%, 1/8 w.	R707	19B800607P472	Metal film: 4.7K ohms + or -5%, 1/8 w.
C810	19A702052P14	Ceramic: 0.01 uF + or -10%, 50 VDCW.	R1	19B800607P470	Metal film: 47 ohms + or -5%, 1/8 w.	R305	19B800607P103	Metal film: 10K ohms + or -5%, 1/8 w.	R708 and R709	19B800607P473	Metal film: 47K ohms + or -5%, 1/8 w.
C811	19A702061P99	Ceramic: 1000 pF + or -5%, 50 VDCW, temp coef 0 + or -30 PPM/°C.	R2	19B800607P183	Metal film: 18K ohms + or -5%, 1/8 w.	R306	19B800607P222	Metal film: 2.2K ohms + or -5%, 1/8 w.	R710 thru R712	19B800607P103	Metal film: 10K ohms + or -5%, 1/8 w.
C812	19A702061P13	Ceramic: 3.3 pF + or -0.25 pF, temp or -30 PPM/°C. (Used in G8).	R3	19B800607P680	Metal film: 68 ohms + or -5%, 1/8 w.	R307	19A702931P230	Metal film: 2000 ohms + or -1%, 200 VDCW, 1/8 w.	R720	19B800607P392	Metal film: 3.9K ohms + or -5%, 1/8 w.
C812	19A702061P5	Ceramic: 2.2 pF + or -0.5 pF, 50 VDCW, temp or -120 PPM. (Used in G6, G7, G3).	R4 and R5	19B800607P100	Metal film: 10 ohms + or -5%, 1/8 w.	R308	19A702931P249	Metal film: 3160 ohms + or -1%, 200 VDCW, 1/8 w.	R721	19B800607P562	Metal film: 5.6K ohms + or -5%, 1/8 w.
C813 and C814	19A702061P21	Ceramic: 15 pF + or -5%, 50 VDCW, temp coef 0 + or -30 PPM. . (Used in G6, G7, G3).	R6	19B800607P824	Metal film: 820K ohms + or -5%, 1/8 w.	R309	19B800607P471	Metal film: 470 ohms + or -5%, 1/8 w.	R722	19B800607P473	Metal film: 47K ohms + or -5%, 1/8 w.
C813 and C814	19A702061P32	Ceramic: 18 pF + or -5%, 50 VDCW, temp coef 0 + or -30 PPM/°C. (Used in G8).	R7	19B800607P104	Metal film: 100K ohms + or -5%, 1/8 w.	R310	19B800607P470	Metal film: 47 ohms + or -5%, 1/8 w.	R723	19B800607P391	Metal film: 390 ohms + or -5%, 1/8 w.
C813 and C814	19A702236P28	Ceramic: 12 pF + or -5%, 50 VDCW, temp coef 0 + or -30 PPM. . (Used in G9 & G10).	R8	19B800607P102	Metal film: 1K ohms + or -5%, 1/8 w.	R311 and R312	19B800607P103	Metal film: 10K ohms + or -5%, 1/8 w.	R724	19B800607P101	Metal film: 100 ohms + or -5%, 1/8 w.
		----- DIODES -----	R9	19B800607P152	Metal film: 1.5K ohms + or -5%, 1/8 w. (Used in G6).	R313	19B800607P103	Metal Film: 10K ohms + or -5%, 1/8w.	R801 thru R803	19B800607P102	Metal film: 1K ohms + or -5%, 1/8 w.
CR701	19A703595P10	Optoelectic: Red LED; sim to HP HLMP-1301-010.	R101	REP 645 624/27	Metal film: 2.7K ohms + or -5%, 1/8 w.	R401	19B800607P330	Metal film: 33 ohms + or -5%, 1/8 w.	R804 thru R806	19B800607P101	Metal film: 100 ohms + or -5%, 1/8 w.
D1	19A705377P1	Silicon, Hot Carrier: sim to MMB0201. (Used in G40, G3, G6).	R102	19B800607P103	Metal film: 10K ohms + or -5%, 1/8 w.	R402	19B800607P102	Metal film: 1K ohms + or -5%, 1/8 w.	R807	19B800607P182	Metal film: 1.8K ohms + or -5%, 1/8 w.
D2 and D3	19A149674P3	High tuning ratio diode: sim to Toko KV1430.	R103	19B800607P473	Metal film: 47K ohms + or -5%, 1/8 w.	R403	19B800607P104	Metal film: 100K ohms + or -5%, 1/8 w.	R808	19B800607P103	Metal film: 10K ohms + or -5%, 1/8 w.
		----- FILTERS -----	R104	19B800607P472	Metal film: 4.7K ohms + or -5%, 1/8 w.	R404	19B800607P561	Metal film: 560 ohms + or -5%, 1/8 w.	R809	19B800607P270	Metal film: 27 ohms + or -5%, 1/8 w.
FL201	19A705458P8	Filter: 378-402 MHz; sim to 302MXPR-1785A (Used in G8).	R105	19B800607P392	Metal film: 3.9K ohms + or -5%, 1/8 w.	R405	19B800607P510	Metal film: 51 ohms + or -5%, 1/8 w.	R810	19B800607P101	Metal film: 100 ohms + or -5%, 1/8 w.
FL201	19A705458P5	Helical, UHF: 424-450 MHz. (Used in G7).	R201 and R202	19B800607P180	Metal film: 18 ohms + or -5%, 1/8 w.	R406	19B800607P101	Metal film: 100 ohms + or -5%, 1/8 w.			----- INTEGRATED CIRCUITS -----
FL201	19A705458P4	Helical, UHF: 403-425 MHz. (Used in G6).				R407	19B800607P104	Metal film: 100K ohms + or -5%, 1/8 w.	U201	19A705927P1	Silicon, bipolar: sim to AvanteK MSA-0611.
FL201	19A705458P1	Helical, UHF: 450-470 MHz. (Used in G3)				R408	19B800607P100	Metal film: 10 ohms + or -5%, 1/8 w.	U202	344A3907P1	Integrated circuit, MMIC: sim to AvanteK MSA-1105.
FL201	19A705458P6	Helical, UHF: 492-512 MHz. (Used in G10)				R409	19B800607P222	Metal film: 2.2K ohms + or -5%, 1/8 w.	U203	19A705927P1	Silicon, bipolar: sim to AvanteK MSA-0611.
						R410	19B800607P392	Metal film: 3.9K ohms + or -5%, 1/8 w.	U301	19A704971P9	Positive Voltage Regulator, 5 volt; sim to MC78L05ACD.
						R411	19B800607P562	Metal film: 5.6K ohms + or -5%, 1/8 w.	U302	19A116297P7	Linear: Dual Op Amp; sim to MC4558CD.
						R412	19B800607P223	Metal film: 22K ohms + or -5%, 1/8 w. (Used IN G3, G6, G7, G8).			

SYMBOL	PART NO.	DESCRIPTION
U303	19A704971P7	Voltage Regulator, Negative: sim to Motorola MC79L05ACD.
U401	19A149944P201	Dual Modulus Prescaler: sim to Motorola MC12022A.
U402	19B800902P7	Synthesizer, custom: CMOS, serial input (Replaced 19B800902P5).
U501	344A3070P1	Dual Operational Amplifier: sim to Motorola TL072.
U502	19A702705P4	Digital: Quad Analog Switch/Multiplexer.
U601	19A116297P7	Linear: Dual Op Amp; sim to MC4558CD.
U701	19A703483P302	Digital: Quad 2-Input NAND Gate; sim to 74HC00.
U702	19A703471P320	Digital: 3-Line To 8-Line Decoder; sim to 74HC138.
U705	19A703483P302	Digital: Quad 2-Input NAND Gate; sim to 74HC00.
VR601 and VR602	19B235029P7	5 Turn Cermet Trimmer: 5K ohms, + or - 10%, .5w, sim to 3296W-1502-R.

PRODUCTION CHANGES

Changes in the equipment to improve or to simplify circuits are identified by a "Revision Letter", which is stamped after the model number of the unit. The revision stamped on the unit includes all previous revisions. Refer to the Parts List for descriptions of parts affected by these revisions.

REV. A - TRANSMITTER SYNTHESIZER BOARD 19D902779G3,6,7

To correct loading problem on synth IC which could cause failure to lock on channel.
R707 was 47k ohms (19B800607P473).

REV. B - TRANSMITTER SYNTHESIZER BOARD 19D902779G3, G6-G7

REV. A - TRANSMITTER SYNTHESIZER BOARD 19D902779G8

To make new band splits compatible with helical filters. New PWB.
C15 was 0.1 μ F (19A700004P2).
C16 was 330 pF (19A702061P73).

REV. A - TRANSMITTER SYNTHESIZER BOARD 19D902779G9

REV. B - TRANSMITTER SYNTHESIZER BOARD 19D902779G8

REV. C - TRANSMITTER SYNTHESIZER BOARD 19D902779G3, G6, G7

To meet hum & noise performance.
R101 was 47K ohm (19B800607P473).
C16 was 1500 pF (19A702061P89).
R9 was 680 ohm (19B800607P681) for G9.
R211 was 15 ohm (19B800607P150) for G9.
R214 was 15 ohm (19B800607P150) for G9.
R507 was 27K ohm (19B800607P150) for G9.
C5 was 3.9 pF (19A702236P15) for G9.
C6 was 18 pF (19A702236P32) for G9.
PWB was R1 return to R0.

REV. D - TRANSMITTER SYNTHESIZER BOARD 19D902779G3

To improve performance, C5 was 3.3 pF (19A702236P13).

REV. D - TRANSMITTER SYNTHESIZER BOARD 19D902779G6

To improve VCO tuning range, R9 was 680 ohms (19B800607P681).

REV. C - TRANSMITTER SYNTHESIZER BOARD 19D902779G8

To improve output level a wire was soldered between pins 3 and 4 and between pins 9, 10 and 17 of FL101.

REV. A - TRANSMITTER SYNTHESIZER BOARD 19D902779G10

Adjust tuning range, C4 changed from 4.7 pF (19A702236P17) to 2.7 pF (19A702236P11).

REV. E - TRANSMITTER SYNTHESIZER BOARD 19D902779G3 & G6

REV. D - TRANSMITTER SYNTHESIZER BOARD 19D902779G7 & G8

REV. B - TRANSMITTER SYNTHESIZER BOARD 19D902779G9 & G10

To accommodate new SOG synthesizer IC package U402 (PLCC package discontinued). Modified printed wire board layout (Printed wire board changed from 19D903361P1R0 to 19D903361P1R3). Changed U402. U402 was a 19B800902P5. Installed RC compensation network resistor R313 and capacitor C314 in 8-volt regulator circuit.

To make trimmer C10 adjustable to the required voltage level, 2.5 \pm 0.05 V. Changed capacitor C4 (19A702236P8) of Schematic Diagram, Sheet 1 "Table of Values" under column G3 From 1.5pF to 2.2 pF (19A702236P10).

REV. F - TRANSMITTER SYNTHESIZER BOARD 19D902779G3

To improve synthesizer power output at the high end of the band by increasing the upper roll off point of the band pass filter. Changed capacitor C209 in "Table of Values" under G3 from 2.2 pF to 1.8 pF. Changed Resistors R211 and R214 in the "Table of Values" from 15 to 12. Deleted from the following designators the value only and added an asterisk to C208, C210, R210, R212, R213 & R215. Added C208, C210, R212, R213 & R215 to the "Table of Values".

REV. C - TRANSMITTER SYNTHESIZER BOARD 19D902779G10

To improve ability to set high and low frequency modulation pots (VR601 & VR602). Also, to improve marginal output power at the high end of the band. Changed capacitor C209 and inductor L204. Capacitor C209, for G10, was 19A702236P8 (1.5 pF). Inductor L204 was 19A705470P10 (56 nH).

REV. A - TRANSMITTER SYNTHESIZER MODULE 19D902780G3, G6 THRU G10

To install RF shielding grommets. Installed item 9 RF shielding grommets (19B802690P1) on two BNC connectors of input/output RF ports.

REV. B - TRANSMITTER SYNTHESIZER MODULE 19D902780G3, G6 THRU G10

To install a cover that has a conductive gasket. Changed item 3. Item 3 was 19D902509P2.

REV. G - TRANSMITTER SYNTHESIZER BOARD 19D902779G3

REV. F - TRANSMITTER SYNTHESIZER BOARD 19D902779G6

REV. E - TRANSMITTER SYNTHESIZER BOARD 19D902779G7

REV. E - TRANSMITTER SYNTHESIZER BOARD 19D902779G8

REV. C - TRANSMITTER SYNTHESIZER BOARD 19D902779G9

REV. D - TRANSMITTER SYNTHESIZER BOARD 19D902779G10

To increase the base current of transistor Q101 and ensure saturation during turn on. Changed resistor R101. Resistor R101 was 19B800607P103, 10K Ohms.

REV. F - TRANSMITTER SYNTHESIZER BOARD 19D902779G7

To set 2.0 VDC on the VCO per Test Specification. Deleted capacitor C4. Capacitor C4 was 1.5 pF, 19A702236P8. Changed capacitor C5. Capacitor C5 was 3.9pF 19A702236P15.

REV. F - TRANSMITTER SYNTHESIZER BOARD 19D902779G8

To enable the VCO voltage to be adjusted properly, with variable capacitor C10 set near the center of its adjustment range. Changed inductor L1 and capacitors C4 and C6. Inductor L1 was 1-1/2 turn RF coil 19C85100P3. Capacitor C4 was 0.5pF 19A702236P1. Capacitor C6 was 12 pF, 19A702236P28.

REV. H - TRANSMITTER SYNTHESIZER BOARD 19D902779G3

To improve synthesizer ability to lock consistently and reliably onto the correct frequency by changing the inductors. Inductor L2 was 19A705470P24 (0.82 uH).

REV. 3A - TRANSMITTER SYNTHESIZER MODULE 19D902780G3, G6-G10

To reduce RF emissions, the conductive connector grommet was replaced with a thicker part to ensure contact with front panel at RF connectors. RF Shielding grommet was 19B802690.

REV. 9A - TRANSMITTER SYNTHESIZER BOARD 19D902779G3

REV. 7A - TRANSMITTER SYNTHESIZER BOARD 19D902779G6-G8

REV. 4A - TRANSMITTER SYNTHESIZER BOARD 19D902779G9

REV. 5A - TRANSMITTER SYNTHESIZER BOARD 19D902779G10

To reduce RF emissions, the conductive gasket AG102834V1 on solder side of board to close slot between board and chassis adjacent to backplane connector.

U201 and U203
19A705927P11
Silicon Bipolar MMIC

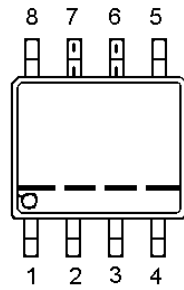

PIN	FUNCTION
1	Vout
2	GROUND
3	GROUND
4	N.C.
5	N.C.
6	GROUND
7	GROUND
8	Vin

U202
344A3907P1
Silicon Bipolar MMIC

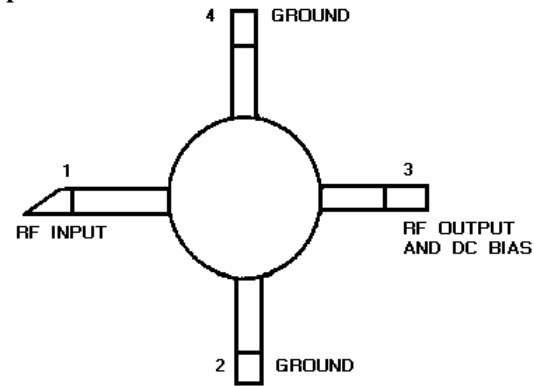

U301
19A704971P9
+5V Regulator

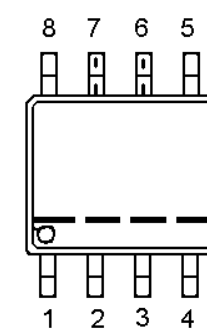

PIN	FUNCTION
1	Vout
2	GROUND
3	GROUND
4	N.C.
5	N.C.
6	GROUND
7	GROUND
8	Vin

U303
19A704971P7
-5V regulator

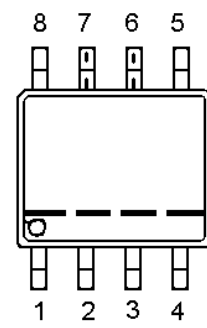

PIN	FUNCTION
1	Vout
2	GROUND
3	GROUND
4	N.C.
5	N.C.
6	GROUND
7	GROUND
8	Vin

U302 & U601
19A116297P7
Dual Wide Band Op-Amp

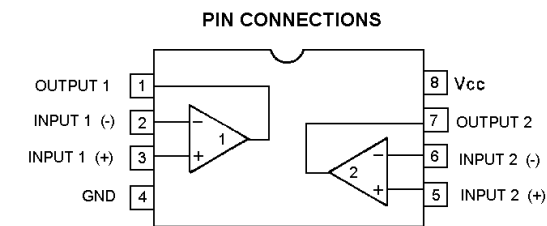

U501
344A3070P1
Operational Amplifier

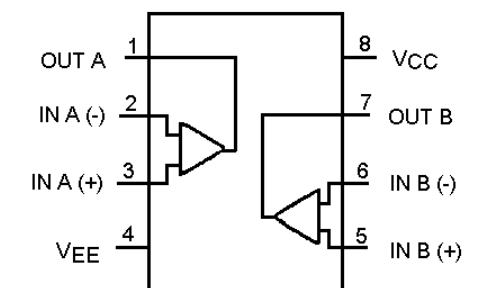

U401
19A149944P201
 Dual Modulus Prescaler

FUNCTION TABLE		
SW	MC	DIVIDE RATIO
H	H	64
H	L	65
L	H	128
L	L	129

SW: H = V_{CC} L = OPEN
 MC: H = 2.0V TO V_{CC}
 L = GND TO 0.8V

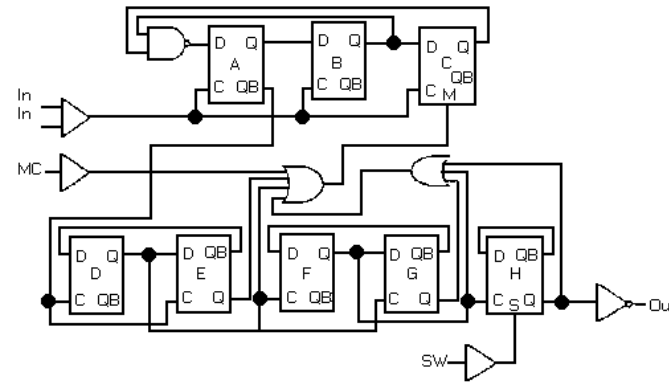

U701 & U705
19A703483P302
 Quad 2-Input NAND Gate

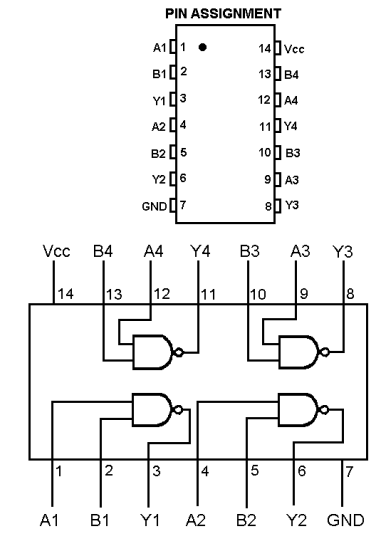

U402
19B800902P7
 Synthesizer

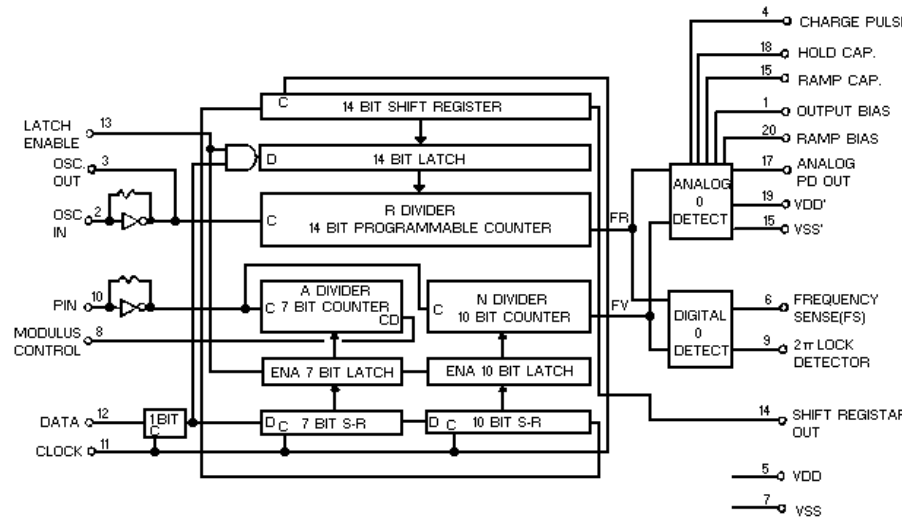
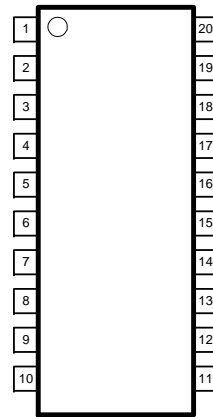

U702
19A703471P120
 Address Decoder

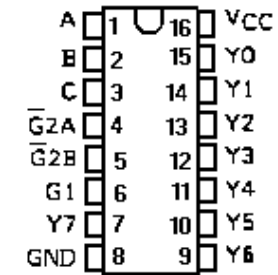
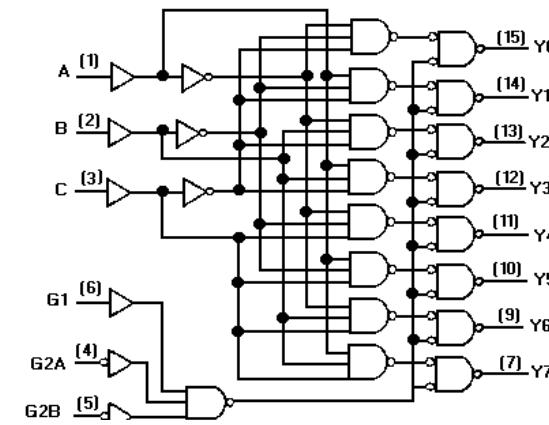

U502
19A702705P4
 Quad Analog Switch

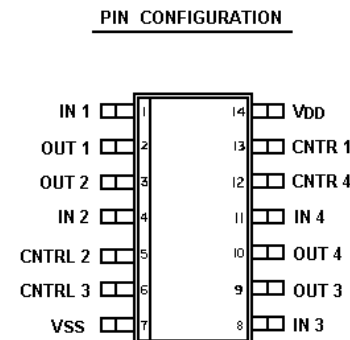

LOGIC DIAGRAM

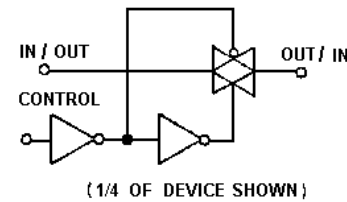

CONTROL	SWITCH
0	OFF
1	ON

FUNCTION TABLE

ENABLE INPUTS			SELECT INPUTS			OUTPUTS							
G1	G2A	G2B	C	B	A	Y0	Y1	Y2	Y3	Y4	Y5	Y6	Y7
x	H	x	x	x	x	H	H	H	H	H	H	H	H
x	x	l	x	x	x	H	H	H	H	H	H	H	H
L	x	x	x	x	x	H	H	H	H	H	H	H	H
H	L	L	L	L	L	L	H	H	H	H	H	H	H
H	L	L	L	L	H	H	L	H	H	H	H	H	H
H	L	L	L	H	L	H	H	L	H	H	H	H	H
H	L	L	L	H	H	H	H	H	L	H	H	H	H
H	L	L	L	H	L	H	H	H	H	L	H	H	H
H	L	L	L	H	H	H	H	H	H	H	L	H	H
H	L	L	L	H	H	H	H	H	H	H	H	L	H
H	L	L	L	H	H	H	H	H	H	H	H	H	L

COMPONENT SIDE

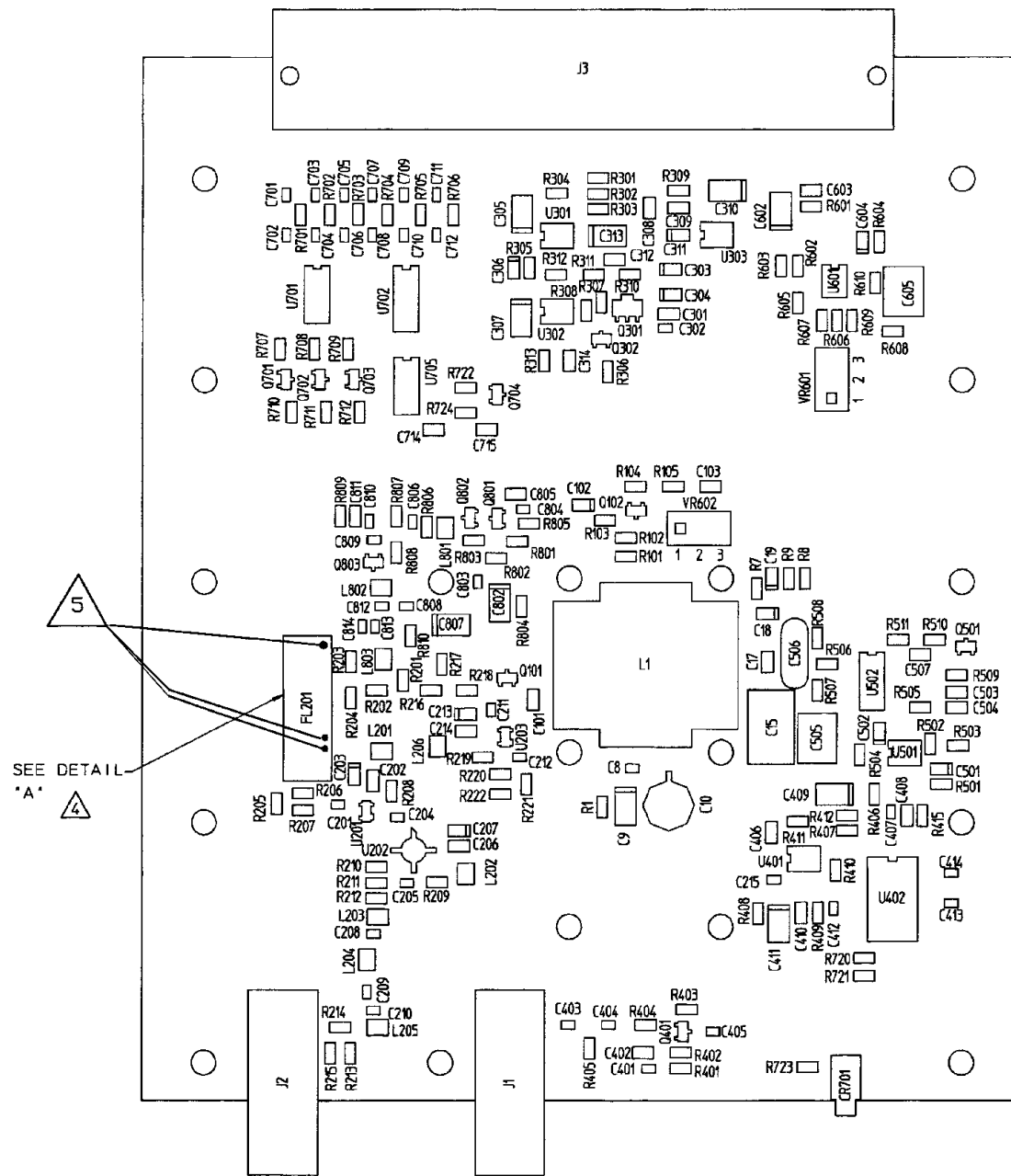

SOLDER SIDE

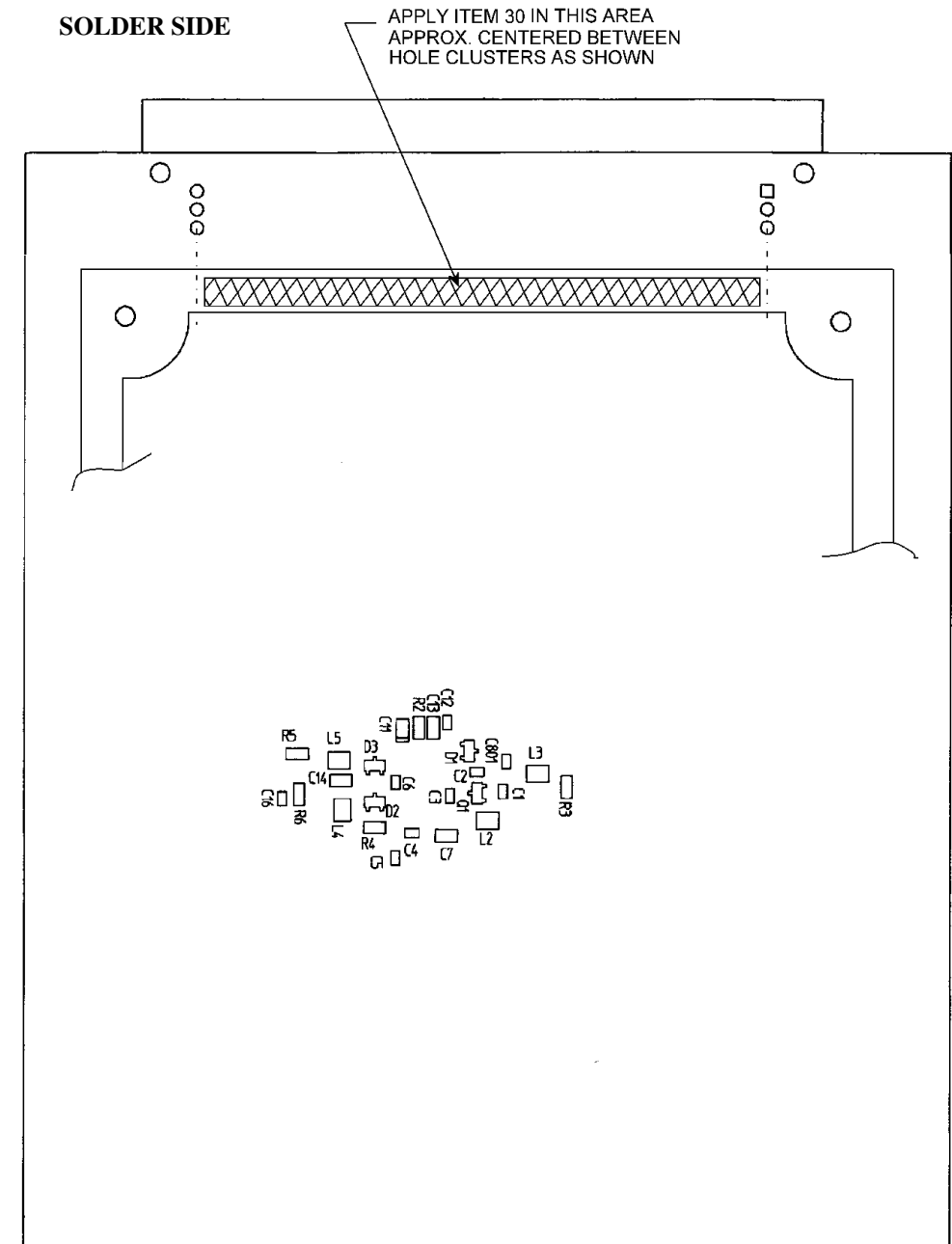

APPLY ITEM 30 IN THIS AREA
APPROX. CENTERED BETWEEN
HOLE CLUSTERS AS SHOWN



UHF TRANSMITTER
SYNTHESIZER BOARD
19D902779G3, G6 - G10

(19D902779, Sh. 2, Rev. 15)

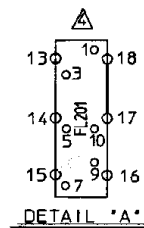

COMPONENT SIDE

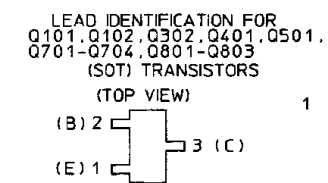
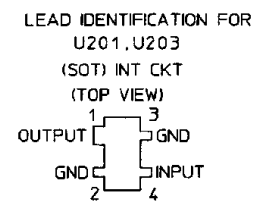
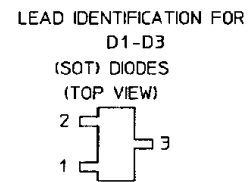
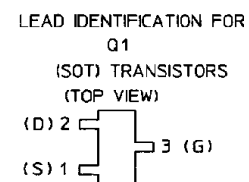

VIEWED FROM SOLDER SIDE OF BOARD

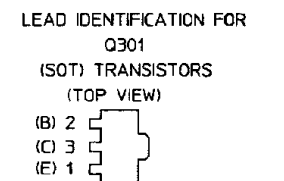
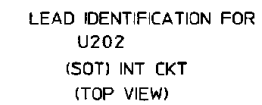

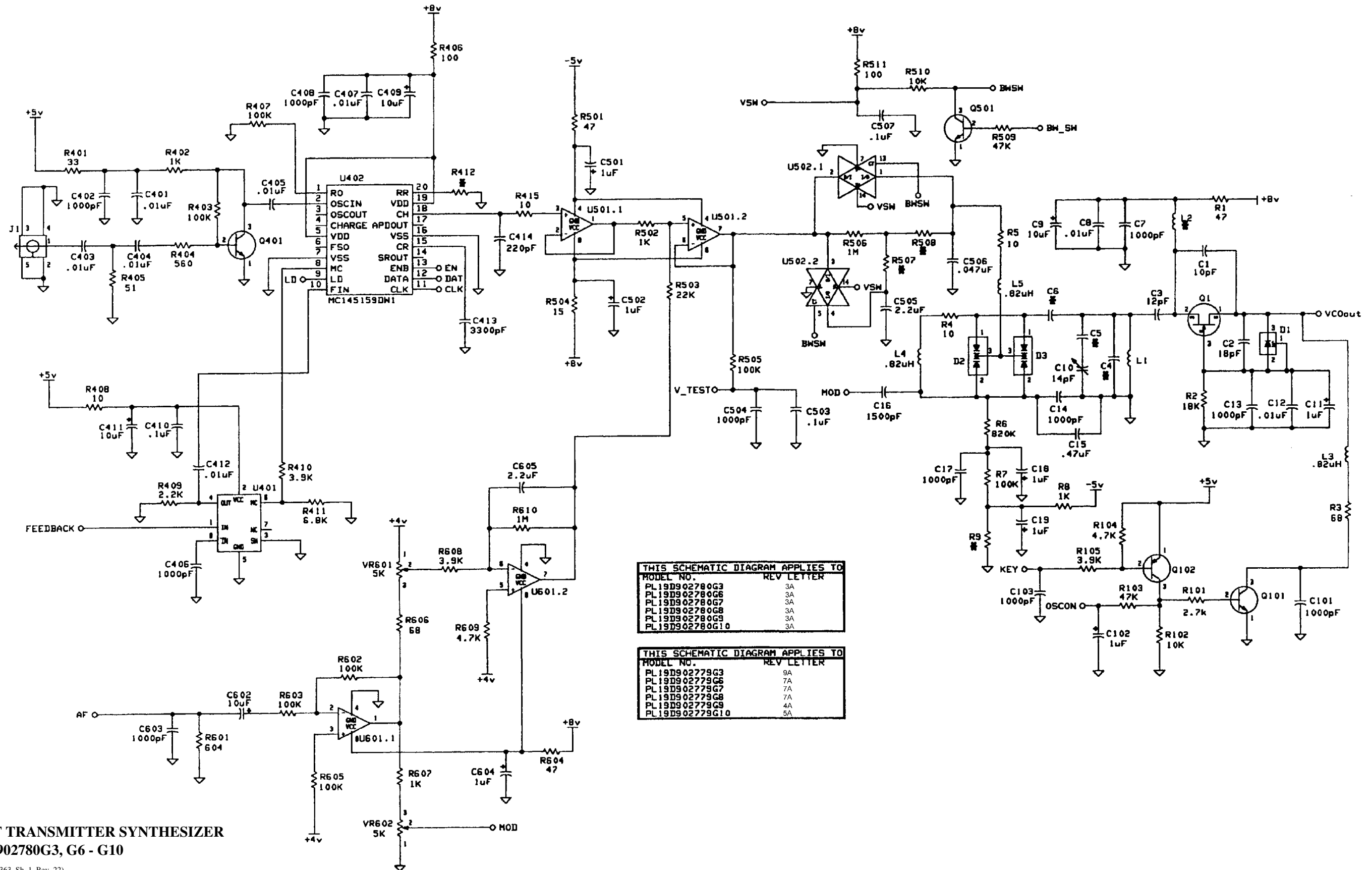

**UHF TRANSMITTER SYNTHESIZER
19D902780G3, G6 - G10**

(19D903363, Sh. 1, Rev. 22)

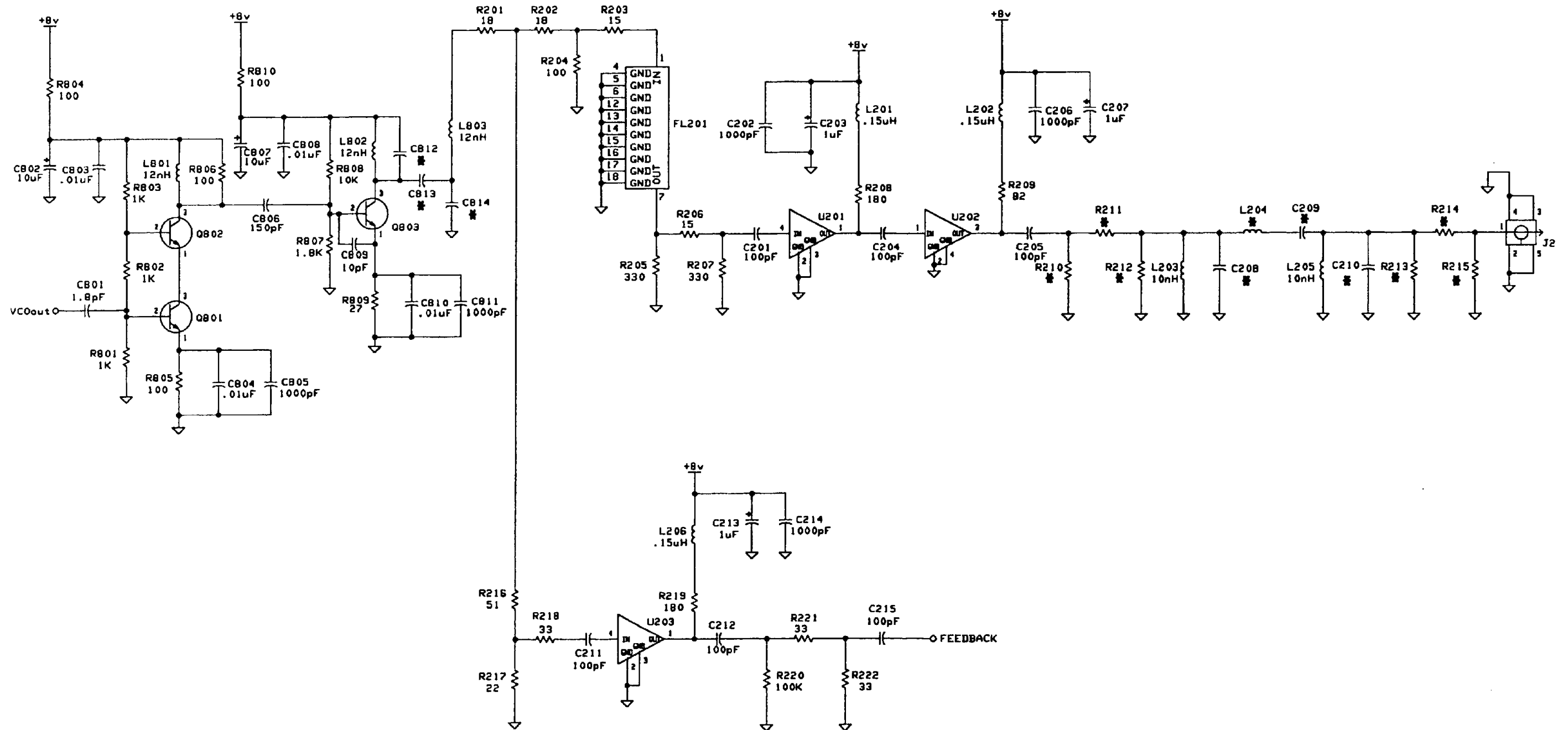

UHF TRANSMITTER SYNTHESIZER
19D902780G3, G6 - G10

(19D903363, Sh. 2, Rev. 22)

TABLE OF VALUES

REF. DES.	VALUE					
	G3 450-470	G6 403-425	G7 425-450	G8 380-400	G9 470-494	G10 492-512
C4	2.2pF	NOT USED	NOT USED	.5pF	4.7pF	2.7 pF
C5	4.7pF	4.7pF	10 pF	4.7pF	4.7pF	4.7pF
C6	12pF	15pF	15pF	18pF	12pF	12pF
C208	10pF	12pF	12pF	12pF	12pF	12pF
C209	1.8pF	2.2pF	2.2pF	2.2pF	1.5pF	1.8pF
C210	10pF	12pF	12pF	12pF	12pF	12pF
C812	2.2pF	2.2pF	2.2pF	3.3pF	NOT USED	NOT USED
C813	15pF	15pF	15pF	18pF	12pF	12pF
C814	15pF	15pF	15pF	18pF	12pF	12pF
L2	1.8uH	.82uH	.82uH	.82uH	1.8uH	1.8uH
L204	56nH	56nH	56nH	56nH	56nH	47nH
R9	680	1.5K	680	680	1K	1K
R210	470	330	330	330	330	330
R211	12	15	15	15	12	12
R212	470	330	330	330	330	330
R213	470	330	330	330	330	330
R214	12	15	15	15	12	12
R215	470	330	330	330	330	330
R412	22K	22K	22K	22K	82K	82K
R507	18K	18K	18K	18K	39K	39K
R508	33K	33K	33K	33K	82K	82K

The following capacitors can be changed from the standard values to enable variable capacitor C10 to be centered in its adjustment range when the VCO voltage is adjusted to specification.

Capacitor C4 and C5 Selection Table

G3	G6		G7		G8		G9	G10
C4	C4	C5	C4	C5	C4	C5	C4	C4
Remove		P11-2.7pf		P23-8.2pf		P15-3.9pf	P15-3.9pf	P8-1.5pf
P1-0.5pf		P13-3.3pf		P24-9.1pf		P16-4.3pf	P16-4.3pf	P10-2.2pf
P6-1.0pf		P15-3.9pf		P25-10pf		P17-4.7pf	P17-4.7pf	P11-2.7pf
P8-1.5pf		P16-4.3pf	P1-0.5pf		Remove		P18-5.1pf	P13-3.3pf
P10-2.2pf		P17-4.7pf	P6-1.0pf		P1-0.5pf		P19-5.6pf	P15-3.9pf
P11-2.7pf	P1-0.5pf		P8-1.5pf		P6-1.0pf		P20-6.2pf	P16-4.3pf
P13-3.3pf	P6-1.0pf		P10-2.2pf		P8-1.5pf			

Notes:

- 1 Select larger capacitor from table if C10 slug is too low for proper VCO adjustment. Select smaller value capacitor from table if C10 slug is too high for proper VCO adjustment.
- 2 Use capacitors from base part number 19A702236PXX.
- 3 C4 is not installed on G6 or G7 modules during factory build, but can be installed during test and alignment if necessary.
- 4 Adjust C4 first. Only adjust C5 if no more adjustment is possible with C4.