

DESCRIPTION AND MAINTENANCE  
138-174 MHz CUSTOM MVP RECEIVER

TABLE OF CONTENTS

DESCRIPTION .....	Page 1
MAINTENANCE .....	Page 1
Disassembly .....	Page 1
Alignment Procedure .....	Page 3
Test Procedure .....	Page 4
Troubleshooting Procedure .....	Page 5
High Side Injection Modification .....	Page 6

DESCRIPTION

Custom MVP 138 to 174 megahertz receivers are single conversion, super-heterodyne FM receivers designed for one-through four-frequency operation. The solid state receiver utilizes integrated circuits (ICs), monolithic crystal filters and discrete components with each of the crystal filters located between gain stages to provide 85 dB selectivity and maximum protection from desensitization and intermodulation.

The receiver consists of the following modules:

- RF Assembly
- Mixer-IF (MIF)
- Oscillator-Multiplier (Osc-Mult)
- Audio and Squelch circuits (part of System-Audio & Squelch (SAS) board)
- IF Detector (IF Det)
- Optional Ultra-High Sensitivity (UHS) Pre-Amplifier

Audio, supply voltages and control functions are connected to the system board through P903 on the IF Det board, and through W401 to the Osc-Mult board. The regulated +10 Volts is used for all receiver stages except the audio PA stage which operates from the A+ system supply.

Centralized metering jack J601 on the IF Det board is provided for use with GE Test Set 4EX3A11 or Test Kit 4EX8K12. The test set meters the oscillator, multiplier, FM Detector, 10-Volt regulator, and IF amplifier stages. Speaker high and low may be monitored at J1-3 (Hi) and J1-4 (low).

A block diagram of the complete receiver is shown in Figure 1.

Refer to the appropriate Maintenance Manual for complete details on each receiver module as listed in the Table of Contents.

MAINTENANCE

DISASSEMBLY

To gain access to the receiver for servicing, remove the wing nut at the rear of the radio and pull the radio out of the case assembly.

To remove the RF Assembly and MIF board:

1. Carefully disconnect the two leads connected to loop clips J623 and J624 on the IF Detector board.
2. Unplug receiver input cable P301.
3. Remove the two countersunk flat head screws on each side of the system frame assembly and lift out RF Assembly and MIF board.

To remove the Osc-Mult board:

1. Remove the crystal module.
2. Remove the two screws securing the board.
3. Carefully unplug the Osc-Mult board from the adapter board (on the receiver front end).

To remove the IF Det board:

1. Carefully disconnect the two leads connected to loop clips J623 and J624 on the IF Det board.
2. Disconnect the two plugs (P602 and J903) from the IF Det board.
3. Remove the five screws securing the board and lift the board out.

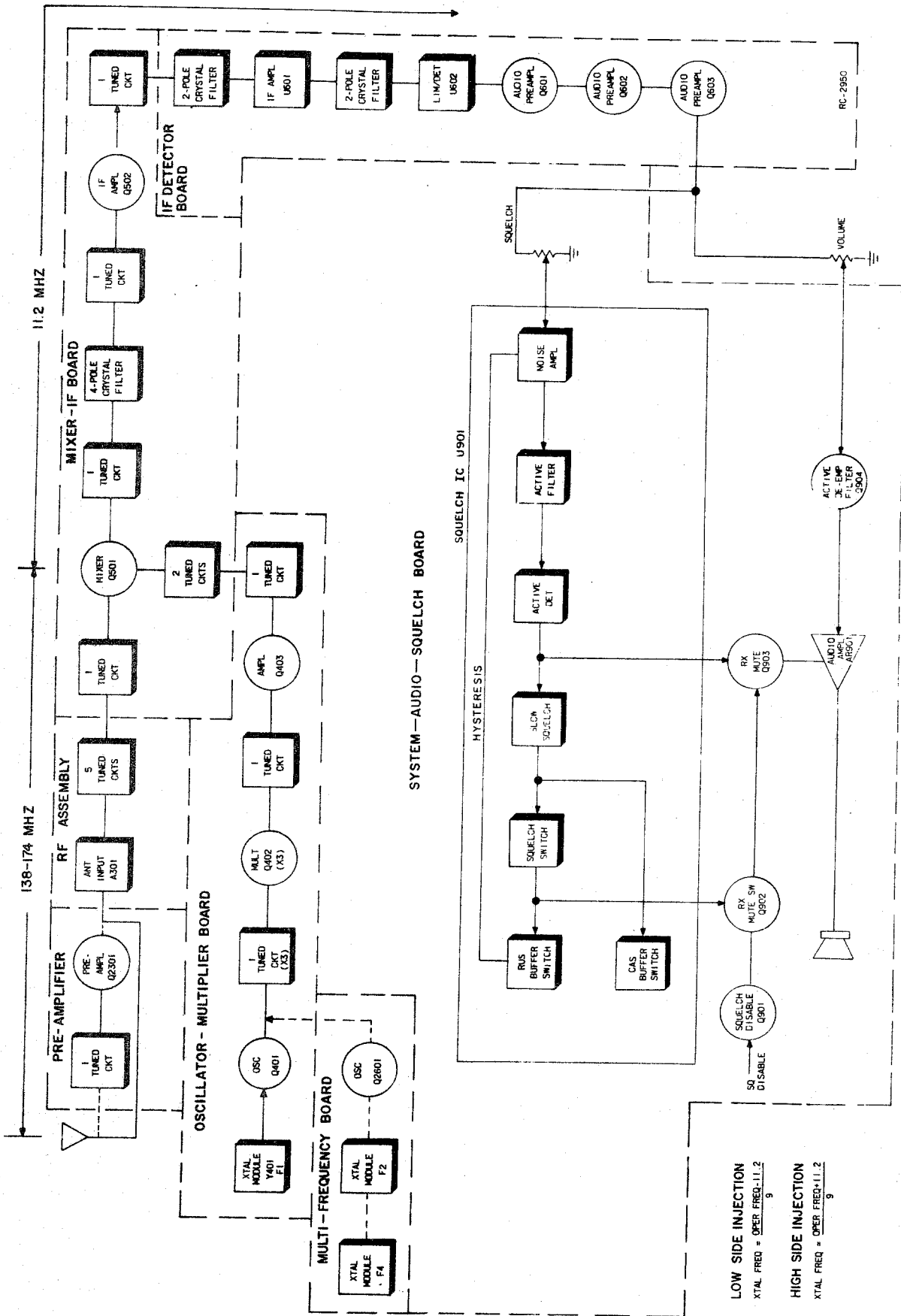

Figure 1 - Receiver Block Diagram

FRONT END ALIGNMENT

- EQUIPMENT
- GE Test Set Models 4EX3A11, 4EX8K12 or 20,000 ohms-per-Volt multimeter with a 1-Volt scale.
  - A 138-174 MHz signal source.

PRELIMINARY CHECKS AND ADJUSTMENTS

- Connect black plug from Test Set to Receiver Centralized Metering Jack J601. Set range selector switch to the TEST 1 position (or 1-Volt position on 4EX8K12).
- For multi-frequency receivers with a frequency spacing up to 0.450 MHz for frequency range of 138-155 MHz, or 0.500 MHz for frequency range of 150.8-174 MHz, align the receiver on the channel nearest center frequency.
- For multi-frequency receivers with a frequency spacing exceeding the above but no greater than .900 MHz for frequency range of 138-155 MHz, or 1.00 MHz for frequency range of 150.8-174 MHz, align the receiver using a center frequency tune-up crystal module. These limits can be extended to 1.60 MHz and 1.80 MHz respectively with 3 dB degradation in standard receiver specifications.
- With Test Set in Position G, check for regulated +10 Volts. If using multimeter, measure between J601-6 (+) and J601-9 (-).
- If using multimeter, connect the negative lead to J601-9 (A-).
- Disable Channel Guard.

ALIGNMENT PROCEDURE

STEP	METERING POSITION GE Test Set	Multimeter - at J601-9	TUNING CONTROL	METER READING	PROCEDURE
<b>OSCILLATOR-MULTIPLIER</b>					
1.	C (MULT-1)	Pin 3	C406	Maximum	Tune C406 for maximum meter reading.
2.			C411, C416, C306, C307	See Procedure	Preset C411 and C416 to a position similar to C406. Next, preset C306 and C307 fully counterclockwise (minimum capacity).
3.	D (MULT-2)	Pin 4	C411, C416, C406	See Procedure	Tune C411 and C416 for maximum meter reading. Next, retune C406, C411 and C416 for maximum meter reading, then, carefully dip C306 and tune C307 for maximum meter reading. Do NOT readjust C306 and C307.
<b>RF SELECTIVITY</b>					
4.	B (IF AMP)	Pin 1	C502, C301 thru C305 (and T2301 if present)	Maximum	Apply an on-frequency signal to the antenna jack, keeping the signal below saturation. Then tune C502 and C301 through C305 for maximum meter reading. In receivers with the UHS preamplifier, also tune T2301 for maximum meter reading.
5.	B (IF AMP)	Pin 1	C502, C301 thru C305 (and T2301 if present)	Maximum	Apply an on-frequency signal to the antenna jack and slightly tune C301 through C305 and C502 (and T2301 if present) for best quieting sensitivity. C306 & C307 may also be tuned slightly (not exceeding 1/4 turn).

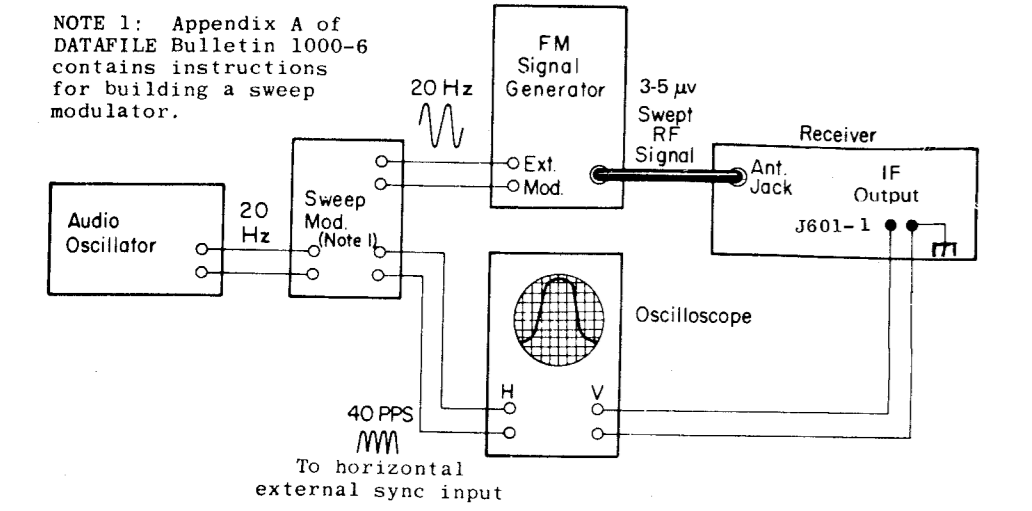

Figure 2 - Test Setup for 20-Hz Double-Trace Sweep Alignment

OSCILLATOR FREQUENCY ADJUSTMENT

First, check the frequency to determine if any adjustment is required. (Refer to frequency offset chart, Figure 3.) The frequency measurement requires equipment with an absolute accuracy that is 5 to 10 times better than the tolerance to be maintained. When adjusting the frequency, the entire radio should be as near as possible to an ambient temperature of 30°C (86°F).

The frequency of the crystal module should only be reset when the measured frequency error exceeds the following limits:  
 A. ±0.6 PPM when the ambient temperature of the radio is 30°C (86°F).  
 B. ±5 PPM at any other temperature within the range of -30°C to +75°C (-22°F to +167°F).

If frequency adjustment is required, refer to one of the procedures below (depending on equipment available) for proper adjustment.

- A. DIRECT MEASUREMENT IN THE INJECTION CHAIN**
- WITH A FREQUENCY COUNTER. "Count" the frequency at the junction of C416 and L403 on the Oscillator-Multiplier board. The frequency measured at this point is 9 times the crystal frequency.
  - WITH A COMMUNICATION MONITOR (for example: Cushman Model CE-3). "Monitor" frequency at the junction of C416 and L403 on the Oscillator-Multiplier board. The frequency monitored at this point is 9 times the crystal frequency. NOTE: This frequency will not always fall within an available measuring range of all monitors at all receiver operating frequencies.
- B. STANDARD "ON FREQUENCY" SIGNAL AT THE RECEIVER INPUT** (Generated from a COMMUNICATION MONITOR, for example: Cushman Model CE-3).
- WITH A FREQUENCY COUNTER. "Count" the developed IF frequency at the tap of Z602-R2 on the IF-DET board. The deviation from the nominal IF frequency (11.2 MHz) in Hz is compared to the receiver operating frequency (also in Hz) to calculate the frequency error.
  - WITH AN 11.2 MHz IF FREQUENCY STANDARD (for example: General Electric Model 4EX9A10). Loosely couple the IF frequency standard to the IF signal path to create a heterodyne with the developed IF frequency. The resultant "beat frequency" can be monitored by any of the following methods:

**NOTE**  
 To set crystal frequency using "beat frequency" method, the temperature should be at 30°C (86°F). If the temperature is not 30°C, then offset the "ON FREQUENCY" signal (at the receiver input), as a function of actual temperature, by the frequency ERROR FACTOR shown in Figure 3.

- Audible "beat frequency" from the receiver speaker (this requires careful frequency adjustment of the frequency standard).
- Observe "beat frequency" at J601-1 with an oscilloscope.
- With GE TEST SET (Meter Position B) connected to J601 on the IF-DET Board, visually observe the "beat frequency" indicated by meter movement.

The frequency of the "beat" is the frequency error related to the IF frequency. This deviation, in Hz, is compared to the receiver operating frequency, also in Hz, to calculate the frequency error.

**NOTE**  
 The FM Detector output (meter position A of the test set) has a DC voltage of .35 to .50 volts at the assigned frequency and is provided for routine test and measurement only. The resolution of this reading (approximately .025 V per kHz as read on a GE Test Set in meter Position A, or 0.1 V per kHz as measured with a VTVM at J601-2 on the IF-DET board) is inadequate for oscillator frequency setting.

If the radio is at an ambient temperature of 30°C (86°F) set the oscillator for the correct mixer frequency (crystal FRQ. X 9).

If the radio is not at an ambient temperature of 30°C setting errors can be minimized as follows:

- A. To hold setting error to ±0.6 PPM (which is considered reasonable for 5 PPM oscillators):**
- Maintain the radio at 30°C (86°F) and set the oscillator to required mixer injection frequency, or
  - Maintain the radio at 30°C (86°F) and offset the oscillator, as a function of actual temperature, by the frequency error shown in Figure 3.

For example: Assume the ambient temperature of the radio is 20°C (68°F). At that temperature, the curve shows a correction factor of 225 Hz.

Adjust the oscillator for a corrected mixer injection frequency 225 Hz higher. If a negative correction factor is obtained (at temperatures above 30°C, set the oscillator for the indicated frequency lower than the calculated mixer injection frequency).

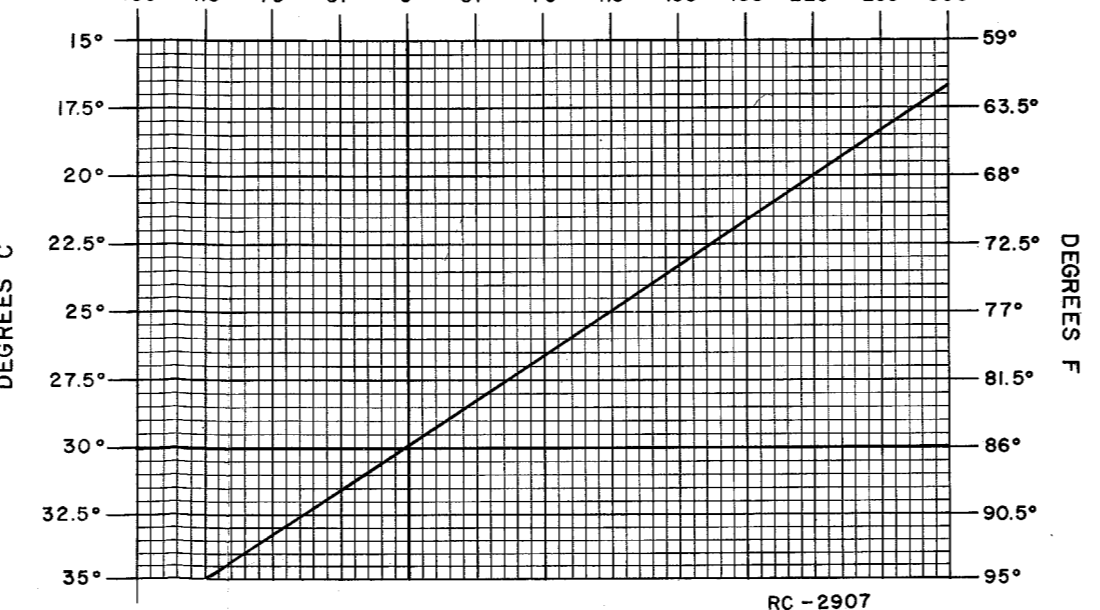
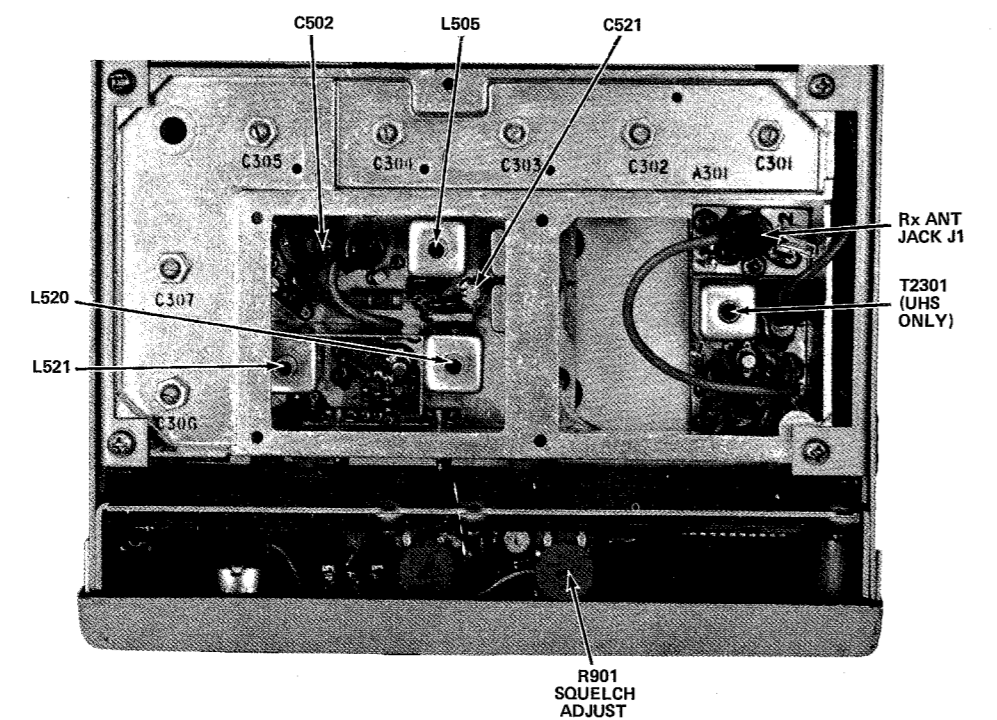
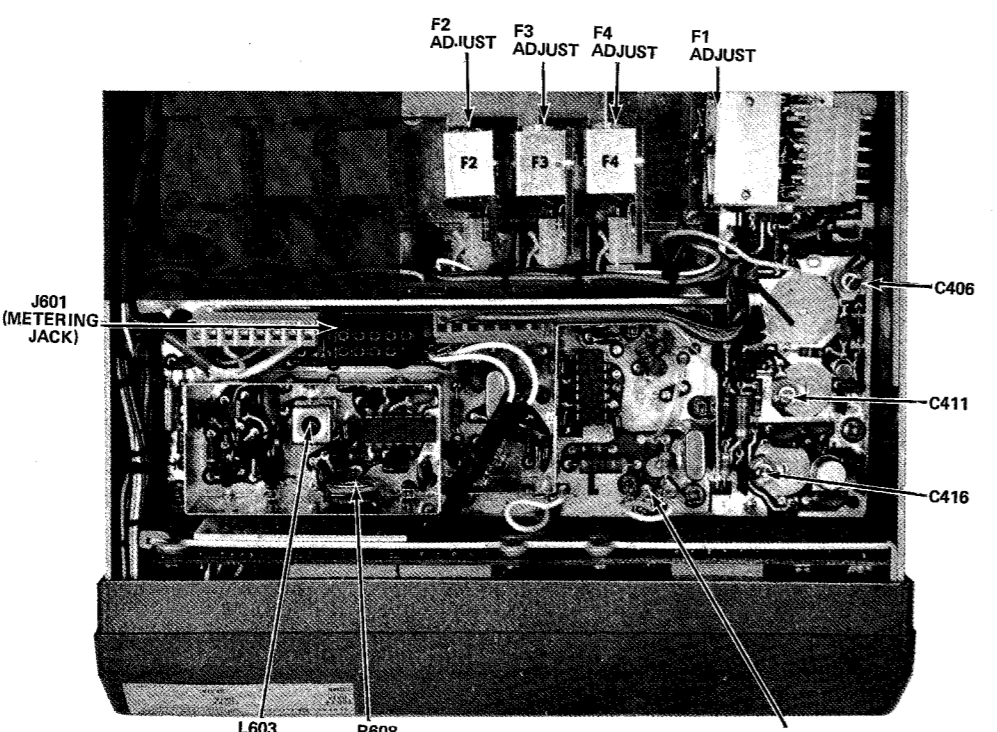

Figure 3 - Frequency Characteristics Vs. Temperature



COMPLETE RECEIVER ALIGNMENT

EQUIPMENT REQUIRED

- GE Test Set Models 4EX3A11, 4EX8K12 or 20,000 ohms-per-Volt multimeter with a 1-Volt scale.
- An 11.2 MHz signal source (GE Test Set Model 4EX9A10). Also a 138-174 MHz signal source with a one-inch piece of insulated wire no larger than .065 inch diameter connected to generator probe.
- Voltmeter.
- Distortion Analyzer.

PRELIMINARY CHECKS AND ADJUSTMENTS

- Connect the black plug from the Test Set to receiver metering jack J601. Set the range selector switch to the Test 1 (or 1-Volt position on the 4EX8K12).
- For multi-frequency receivers with a frequency spacing up to 0.450 MHz for frequency range of 138-155 MHz, or 0.500 MHz for frequency range of 150.8-174 MHz, align the receiver on the channel nearest center frequency.

For multi-frequency receivers with a frequency spacing exceeding the above but no greater than .900 MHz for frequency range of 138-155 MHz, or 1.00 MHz for frequency range of 150.8-174 MHz, align the receiver using a center frequency tune-up crystal module. These limits can be extended to 1.60 MHz and 1.80 MHz respectively with 3 dB degradation in standard receiver specifications.

- With the Test Set in Position G, check for regulated +10 Volts. If using multimeter, measure from J601-6 (+) to J601-9 (-).
- If using multimeter, connect the negative lead to J601-9 (A-).
- Disable the Channel Guard.

ALIGNMENT PROCEDURE

STEP	METERING POSITION GE Test Set	Multimeter - at J601-9	TUNING CONTROL	METER READING	PROCEDURE
<b>FM DETECTOR</b>					
1.	A (FM DET)	Pin 2	L603	0.38 Volt	With no signal applied, adjust L603 for a meter reading of approximately 0.38 Volt.
<b>OSCILLATOR-MULTIPLIER</b>					
2.	C (MULT-1)	Pin 3	C406	Maximum	Tune C406 for maximum meter reading.
3.			C411, C416, C306, C307	See Procedure	Preset C411 and C416 to a position similar to C406. Next, preset C306 and C307 fully counterclockwise (minimum capacity).
4.	D (MULT-2)	Pin 4	C411, C416, C406	See Procedure	Tune C411 and C416 for maximum meter reading. Next, retune C406, C411 and C416 for maximum meter reading, then, carefully dip C306 and tune C307 for maximum meter reading. Do NOT readjust C306 and C307.
<b>RF SELECTIVITY</b>					
5.	B (IF AMP)	Pin 1	C502	Maximum	Apply an on-frequency signal in the hole adjacent to C305 and tune C502 for maximum meter reading.
6.	B (IF AMP)	Pin 1	C305	Maximum	Apply an on-frequency signal in the hole adjacent to C304, keeping the signal below saturation. Then tune C305 for maximum meter reading.
7.	B (IF AMP)	Pin 1	C304	Maximum	Apply an on-frequency signal in the hole adjacent to C303, keeping the signal below saturation. Then tune C304 for maximum meter reading.
8.	B (IF AMP)	Pin 1	C303	Maximum	Apply an on-frequency signal in the hole adjacent to C302, keeping the signal below saturation. Then tune C303 for maximum meter reading.
9.	B (IF AMP)	Pin 1	C302 and C301	Maximum	Apply an on-frequency signal to the antenna jack, keeping the signal below saturation. Then tune C302 and C301 for maximum meter reading.
10.	B (IF AMP)	Pin 1	C502, C301 thru C305 (and T2301 if present)	Maximum	Apply an on-frequency signal to the antenna jack, keeping the signal below saturation. Then tune C502 and C301 through C305 for maximum meter reading. In receivers with the UHS preamplifier, also tune T2301 for maximum meter reading.
11.	B (IF AMP)	Pin 1	C502, C301 thru C305 (and T2301 if present)	Maximum	Apply an on-frequency signal to the antenna jack and slightly tune C301 through C305 and C502 (and T2301 if present) for best quieting sensitivity. C306 & C307 may also be tuned slightly (not exceeding 1/4 turn).
12.			L603 R608	See Procedure	Remove the Test Set metering plug from J601. Apply a 1000 microvolt signal with 1 kHz modulation and 3.0 kHz deviation to the antenna jack. Tune L603 for maximum voltage at 1 kHz and adjust R608 for 1 Volt RMS measured with a VTVM at P903-1 (VOL/SQ HI) and P903-6 (A-).

ALIGNMENT PROCEDURE

STEP	METERING POSITION GE Test Set	Multimeter - at J601-9	TUNING CONTROL	METER READING	PROCEDURE
<b>MIXER &amp; IF</b>					
The mixer and IF circuits have been aligned at the factory and will normally require no further adjustment. If adjustment is necessary, use the procedure outlined in Step 13.					
<b>NOTE</b>					
Refer to DATAFILE BULLETIN 1000-6 (IF Alignment of Two-Way Radio FM Receivers) for helpful suggestions on how to determine when IF Alignment is required.					

13. Connect scope for signal generator, and probe as shown in Figure 2. Set signal generator level for 3 to 5 μV and modulate with 10 kHz at 20 Hz. With probe between J601-1 and A-, tune L505, L520, L521 and C521, for double trace as shown on scope pattern.

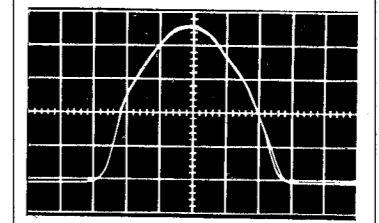

14. See Procedure. Check to see that modulation acceptance bandwidth is greater than ±7.0 kHz.

15. Set SQUELCH ADJUST control (R901) to open with a 6 dB SINAD signal. (Approximately 30° counterclockwise of critical squelch position).

ALIGNMENT PROCEDURE

138-174 MHz CUSTOM MVP RECEIVER

## TEST PROCEDURES

These Test Procedures are designed to help you to service a receiver that is operating---but not properly. The problems encountered could be low power, poor sensitivity, distortion, limiter not operating properly, and low gain. By following the sequence of test steps starting with Step 1, the defect can be quickly localized. Once

the defective stage is pin-pointed, refer to the "Service Check" listed to correct the problem. Additional corrective measures are included in the Troubleshooting Procedure. Before starting with the Receiver Test Procedures, be sure the receiver is tuned and aligned to the proper operating frequency.

### TEST EQUIPMENT REQUIRED

- Distortion Analyzer similar to:  
Heath IM-12
- Signal Generator similar to:  
Measurements 803
- 6-dB attenuation pad, and 3.2-ohm, 5-watt resistor

### PRELIMINARY ADJUSTMENTS

1. Connect the test equipment as shown for all steps of the receiver Test Procedure.
2. Turn the SQUELCH control fully clockwise for all steps of the Test Procedure.
3. Turn on all of the equipment and let it warm up for 20 minutes.

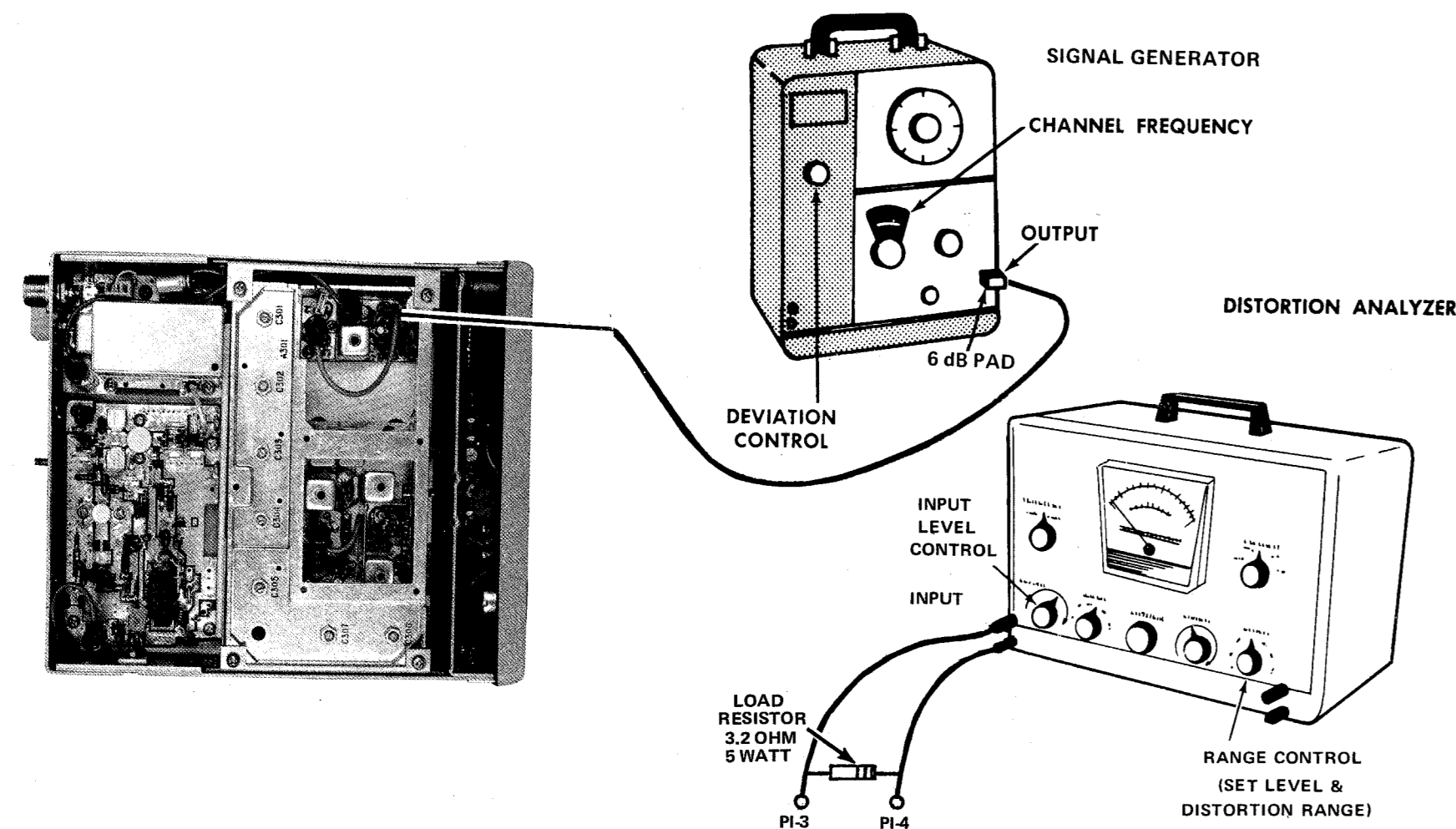

## STEP 1 AUDIO POWER OUTPUT AND DISTORTION

### TEST PROCEDURE

Measure Audio Power Output as follows:

- A. Apply a 1,000-microvolt, on-frequency test signal modulated by 1,000 hertz with  $\pm 3.0$  kHz deviation to antenna jack A301-J1.

- B. With 5-Watt Speaker:

Disconnect speaker and connect a 3.2-ohm, 5-Watt load resistor from P1-3 (Speaker Hi) to P1-4. Connect the Distortion Analyzer input across the resistor as shown.

OR

With Handset:

Lift the handset off of the hookswitch. Connect the Distortion Analyzer input to P1-3 and P1-4.

- C. Adjust the VOLUME control for 3-Watt output using the Distortion Analyzer as a VTVM (3.1 VRMS).
- D. Make distortion measurements according to manufacturer's instructions. Reading should be less than 5%. If the receiver sensitivity is to be measured, leave all controls and equipment as they are.

### SERVICE CHECK

If the distortion is more than 5%, or maximum audio output is less than 5-Watts, make the following checks:

- E. Battery and regulator voltage---low voltage will cause distortion. (Refer to Receiver Schematic Diagram for voltages.)
- F. Audio Gain (Refer to Receiver Troubleshooting Procedure.)
- G. FM Detector Adjustment (Refer to Receiver Alignment on reverse side of page).

## STEP 2 USABLE SENSITIVITY (12-dB SINAD)

If STEP 1 checks out properly, measure the receiver sensitivity as follows:

- A. Apply a 1000-microvolt, on-frequency signal modulated by 1000 Hz with 3.0-kHz deviation to A301-J1.

- B. Place the RANGE switch on the Distortion Analyzer in the 200 to 2000-Hz distortion range position (1000-Hz filter in the circuit). Tune the filter for minimum reading or null on the lowest possible scale (100%, 30%, etc.)

- C. Place the RANGE switch to the SET LEVEL position (filter out of the circuit) and adjust the input LEVEL control for a +2 dB reading on a mid range (30%).

- D. While reducing the signal generator output, switch the RANGE control from SET LEVEL to the distortion range until a 12-dB difference (+2 dB to -10 dB) is obtained between the SET LEVEL and distortion range positions (filter out and filter in).

- E. The 12-dB difference (Signal plus Noise and Distortion to noise plus distortion ratio) is the "usable" sensitivity level. The sensitivity should be less than rated 12 dB SINAD specifications with an audio output of at least 1.5 Watts (2.2 Volts RMS across the 3.2-ohm receiver load using the Distortion Analyzer as a VTVM).

- F. Leave all controls as they are and all equipment connected if the Modulation Acceptance Bandwidth test is to be performed.

### SERVICE CHECK

If the sensitivity level is more than rated 12 dB SINAD, check the alignment of the RF stages as directed in the Alignment Procedure, and make the gain measurements as shown on the Troubleshooting Procedure.

## STEP 3 MODULATION ACCEPTANCE BANDWIDTH (IF BANDWIDTH)

If STEPS 1 and 2 check out properly, measure the bandwidth as follows:

- A. Set the Signal Generator output for twice the microvolt reading obtained in the 12-dB SINAD measurement.

- B. Reduce the audio output to 0.3 watts (0.98V RMS) across the 3.2 ohm receiver load.

- C. Set the RANGE control on the Distortion Analyzer in the SET LEVEL position (1000-Hz filter out of the circuit), and adjust the input LEVEL control for a +2 dB reading on the 30% range.

- D. While increasing the deviation of the Signal Generator, switch the RANGE control from SET LEVEL to distortion range until a 12-dB difference is obtained between the SET LEVEL and distortion range readings (from +2 dB to -10 dB).

- E. The deviation control reading for the 12-dB difference is the Modulation Acceptance Bandwidth of the receiver. It should be more than 7.0 kHz.

### SERVICE CHECK

If the Modulation Acceptance Bandwidth test does not indicate the proper width, make gain measurements as shown on the Receiver Troubleshooting Procedure.

## STEP I - QUICK CHECKS

### TEST SET CHECKS

These checks are typical voltage readings measured with GE Test Set Model 443A11 in the Test 1 position, or Model 443K12 in the 1-Volt position.

Metering Position	Reading With No Signal In	Reading with 1 Micro-volt Unmodulated
A (FM DET)	0.35 to 0.50 VDC	
B (IF Amp)		0.2 VDC
C (Mult-1)	0.45 VDC	
D (Mult-2)	0.1 VDC	
G (Reg. +10 Volts at J601)	+10 VDC	

### SYMPTOM CHECKS

SYMPTOM	PROCEDURE
NO SUPPLY VOLTAGE	• Check power connections and continuity of supply leads, and check fuse. If fuse is blown, check receiver for short circuits.
NO REGULATED 10-VOLTS	• Check the 12-Volt supply. Then check 10-Volt regulator circuit. (See Troubleshooting Procedure for 10-Volt Regulator).
LOW LIM READING	• Check supply voltages and then check oscillator readings at J601-3 & 4 as shown in STEP 2. • Make SIMPLIFIED VTVM GAIN CHECKS from Mixer through 1st Limiter stages as shown in STEP 2.
LOW OSCILLATOR/MULTIPLIER READINGS	• Check alignment of Oscillator/Multiplier. (Refer to Front End Alignment Procedure). • Check voltage readings of Oscillator/Multiplier (Q402, Q403, Q404).
LOW RECEIVER SENSITIVITY	• Check Front End Alignment. (Refer to Receiver Alignment Procedure). • Check antenna connections, cable and antenna switch. • Check Oscillator injection voltage. • Check voltage readings of Mixer and IF Amp. • Make SIMPLIFIED GAIN CHECKS (STEP 2).
IMPROPER SQUELCH OPERATION	• Check voltages on Schematic Diagram. • Make gain and waveform checks with noise. • Make gain and waveform checks with 6 kHz signal. • Check discrete components in the squelch circuit.
LOW OR DISTORTED AUDIO	• Check voltages on Schematic Diagram. • Make gain and waveform checks. • Check receiver and alignment and FM Detector output. • Check Q601, Q602 and Q603 and other discrete components. • Check AR901 on SAS board.

### STEP 4-VOLTAGE RATIO READINGS

**EQUIPMENT REQUIRED**  
 1. RF VOLTMETER

2. SIGNAL ON RECEIVER FREQUENCY (BELOW SATURATION). USE 1000 HERTZ SIGNAL WITH 30KHZ DEVIATION.

**PROCEDURE:**  
 1. APPLY PROBE TO INPUT OF STAGE (FOR EXAMPLE, SOURCE OF RF AMP). PEAK RESONANT CIRCUIT OF STAGE BEING MEASURED AND TAKE VOLTAGE READING (E1).  
 2. MOVE PROBE TO INPUT OF FOLLOWING STAGE (MIXER). REPEAT FIRST RESONANT CIRCUIT THEN PEAK CIRCUIT BEING MEASURED AND TAKE READING (E2).  
 3. CONVERT READINGS BY MEANS OF THE FOLLOWING FORMULA. VOLTAGE RATIO =  $\frac{E_2}{E_1}$   
 4. CHECK RESULTS WITH TYPICAL VOLTAGE RATIOS SHOWN ON DIAGRAM

\* DIFFERENCE BETWEEN INPUT AND OUTPUT READINGS ON dB SCALE OF RF VOLTMETER, NOT ACTUAL POWER GAIN.

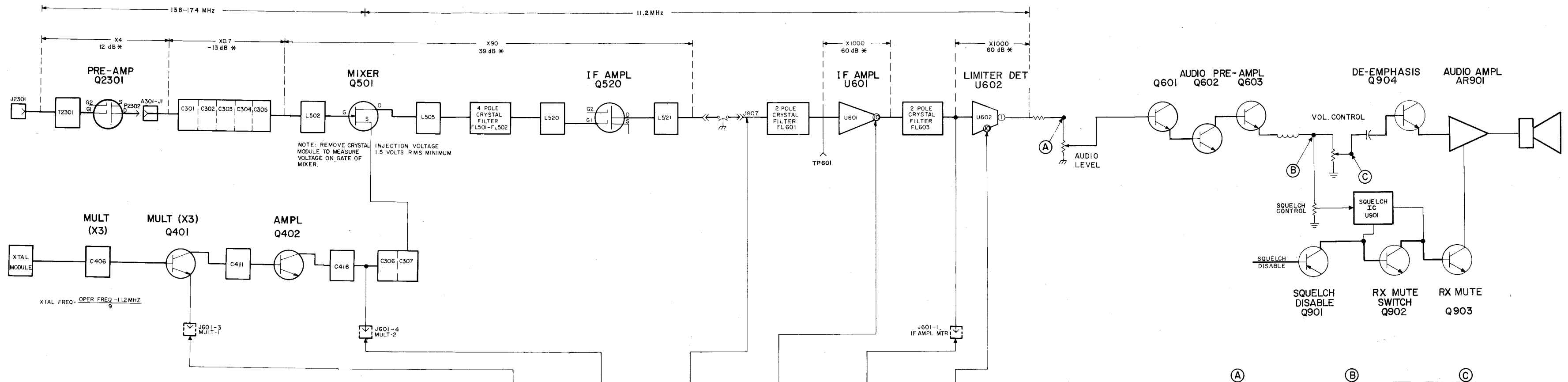

### STEP 2-SIMPLIFIED GAIN CHECKS

**EQUIPMENT REQUIRED:**  
 1. VOLTMETER AC & DC  
 2. SIGNAL GENERATOR  
 3. RF VOLTMETER

**PRELIMINARY STEPS:**  
 1. SET VOLUME CONTROL FOR 3.1 VOLTS ACROSS 3.2-OHM LOAD. IF THIS CANNOT BE OBTAINED, SET TO APPROX. 70% OF MAX. ROTATION.  
 2. SET SQUELCH CONTROL FULLY COUNTERCLOCKWISE.  
 3. RECEIVER SHOULD BE PROPERLY ALIGNED.  
 4. CONNECT METER BETWEEN A- AND POINTS INDICATED BY ARROW.

APPLIED, TO A301-J1	NONE	NONE	UNMODULATED	UNMODULATED	UNMODULATED	NO SIGNAL INPUT
PROCEDURE			SET GENERATOR OUTPUT AT 1000 MICROVOLTS TO RECEIVE FREQUENCY	RESET GENERATOR TO ZERO, THEN INCREASE GENERATOR OUTPUT FROM ZERO UNTIL 1000 SATURATES AS MEASURED WITH RF VOLTMETER	SET GENERATOR OUTPUT FROM ZERO TO 40 MICROVOLTS (10 MICROVOLTS WITH PREAMP)	SHOULD BE IN SATURATION AT ALL TIMES
READING	VOLTMETER READING SHOULD BE APPROX 0.5 VDC	VOLTMETER READING SHOULD BE APPROX 0.2 VDC	RF VOLTMETER READING SHOULD BE APPROX 200 MILLIVOLTS	GENERATOR OUTPUT SHOULD BE APPROX 40 MICROVOLTS (10 MICROVOLTS WITH PREAMP)	VOLTMETER READING SHOULD BE APPROX 0.54 VDC	RF VOLTMETER READING SHOULD BE APPROX 0.6V RMS

**AUDIO WAVEFORMS**  
 STANDARD SIGNAL  
 1. 1000 MICROVOLTS  
 2. 1 KHz MOD.  
 3. 3 KHz DEV.  
 4. VOLUME CONT SET FOR RATED OUTPUT (4 VRMS).

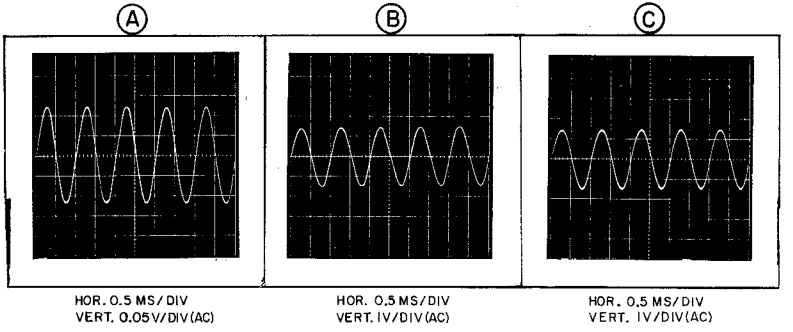

### STEP 3-AUDIO & SQUELCH WAVEFORMS

**EQUIPMENT REQUIRED:**  
 1. OSCILLOSCOPE CONNECTED BETWEEN A- AND POINTS INDICATED BY ARROW.  
 2. SIGNAL GENERATOR  
 3. 6 KHz GENERATOR

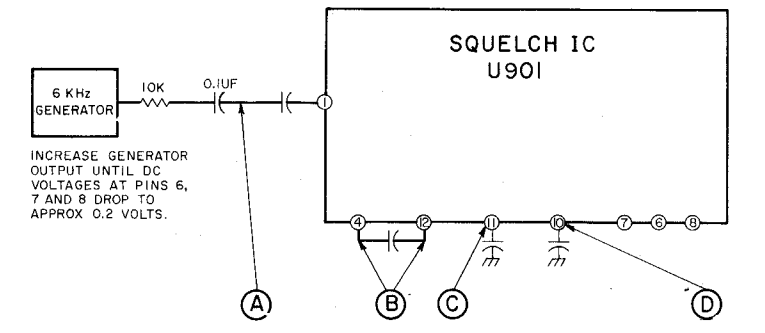

**SQUELCH CIRCUIT CHECKS WITH 6 KHz SIGNAL:**

**PRELIMINARY STEPS**  
 1. QUIET RECEIVER WITH A 1000 MICROVOLT, UNMODULATED SIGNAL.  
 2. SET SQUELCH CONTROL TO APPROX MID-RANGE.  
 3. APPLY 6KHz SIGNAL TO PIN 1 AS SHOWN, AND CHECK WAVEFORMS (A) THRU (D).

**SQUELCH CIRCUIT CHECK WITH NOISE:**

**PRELIMINARY STEPS**  
 1. NO INPUT SIGNAL APPLIED.  
 2. SET SQUELCH CONTROL FOR CRITICAL SQUELCH.  
 3. CHECK WAVEFORMS (A) THRU (D).

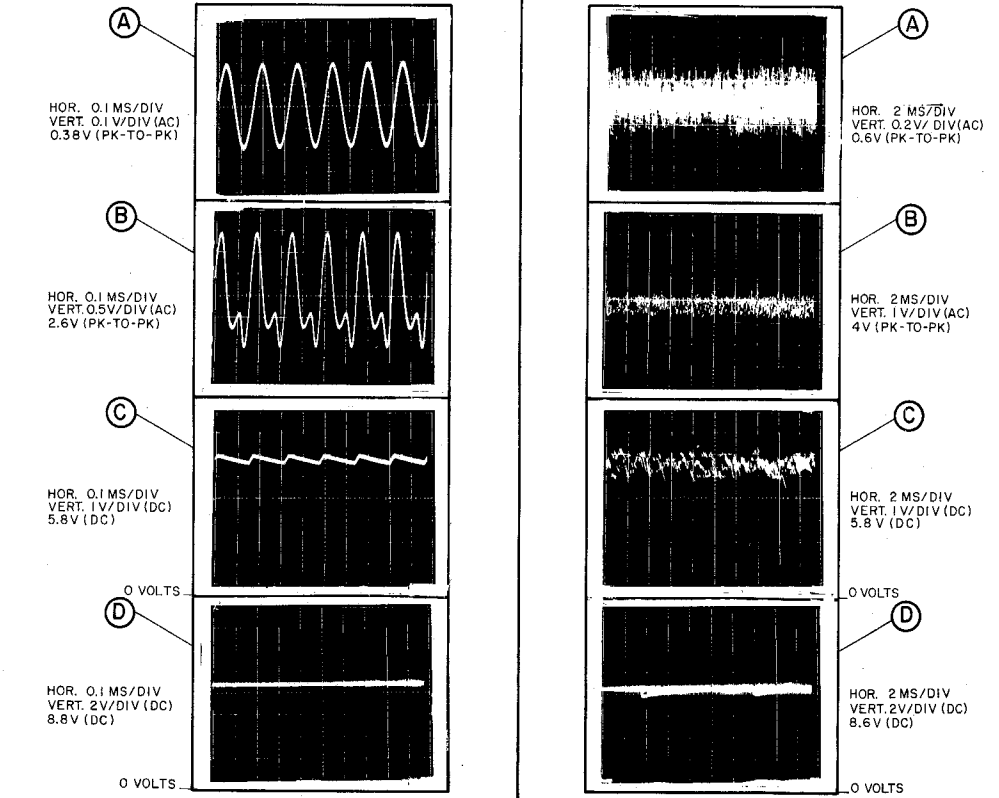

### TROUBLESHOOTING PROCEDURE

138-174 MHz CUSTOM MVP RECEIVER

LABEL  
19A130206P1  
(SEE STEP 5,  
MODIFICATION  
INSTRUCTIONS)

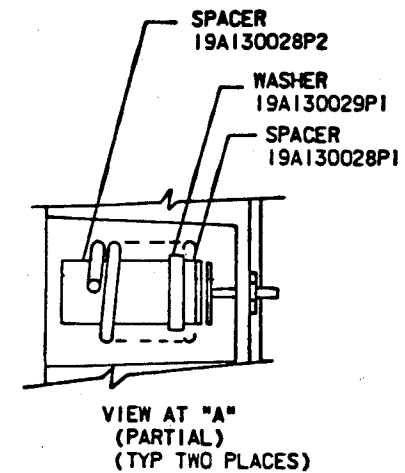
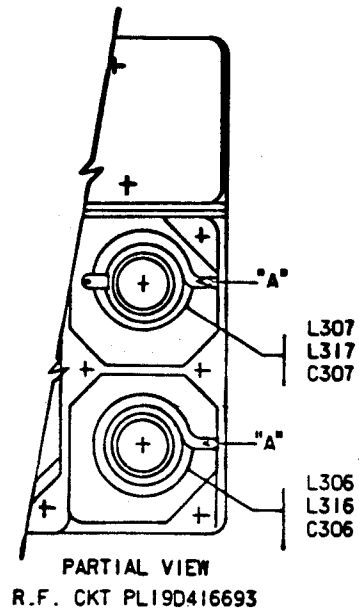
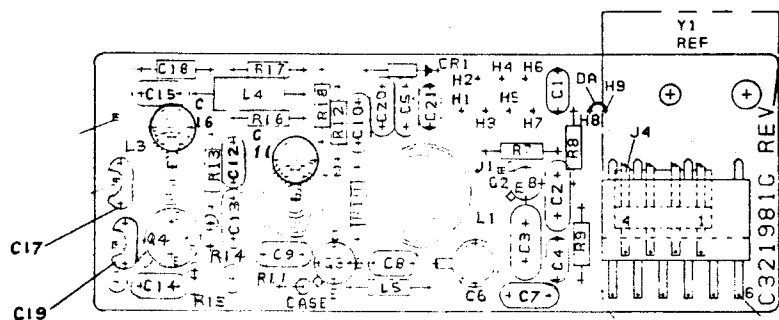
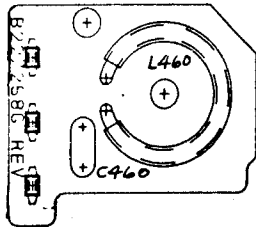
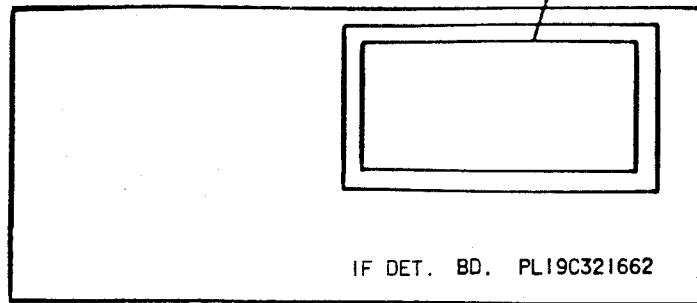

④ MODIFICATION INSTRUCTIONS FOR HIGH BAND HIGH SIDE INJECTION APPLYING 19A130045G1 OR G2 KIT

- ON OSC/MULT. BD. 19C321981G5 (LOW SPLIT) REMOVE C12 & C17. REPLACE C7 WITH C2311 (12pf, NPO), REPLACE C19 WITH C2312 (3pf, NPO). REPLACE C460 (ON 19B227258) WITH C2313 (5pf, NPO). DISCARD C2314.  
ON OSC/MULT. BD. 19C321981G6 (HIGH SPLIT), REMOVE C7 & C12.  
REPLACE C460 (ON 19B227258) WITH C2314 (4pf, NPO).  
DISCARD C2311 AND C2313.  
SOLDER ALL ELECTRICAL CONNECTIONS. C2301 THRU C2314 ARE PART OF MOD KIT 19A130045G1, C2311 THRU C2314 ONLY—G2.
- MODIFY RF. CKT ASM PL19D416693 BY ADDING 19A130028P1 SPACER, 19A130029P1 WASHER, AND 19A130028P2 SPACER AS SHOWN TO L306 & L307 (LOW SPLIT) OR L316, & L317 (HIGH SPLIT). SLIDE SPACERS, & WASHER ON CERAMIC POST FROM TOP IN ORDER SHOWN. THESE ITEMS ARE PART OF MOD KIT PL19A130045G1 AND G2.
- IN APPLICATION OF THIS KIT THE CRYSTAL OSCILLATOR FREQUENCY MUST BE CHANGED PER THE FOLLOWING FORMULA:  
$$F_x = \frac{F_0 + 11.2}{9}$$
- MARK ALL OSC/MULT. BD'S 19C321981 WITH A BLUE COLOR DOT IN THE AREA OF THE PL DRAWING NO. PER 19A115740P1.  
MARK ALL RECEIVER CASTINGS WITH A BLUE COLOR DOT IN THE AREA OF THE PL DRAWING NO. PER 19A115740P1.
- APPLY LABEL (19A130206P1) TO DETECTOR COVER ON IF DET BD.
- TEST AND ALIGN PER NORMAL PROCEDURE WITH THE FOLLOWING EXCEPTION:  
PRE-ADJUST C11 AND C16 TO MINIMUM CAPACITY, THEN TUNE IN SLOWLY.

## HIGH SIDE INJECTION MODIFICATION

138—174 MHz CUSTOM MVP RECEIVER